

# TPS4H160-Q1 40V、160mΩ 四通道智能高侧开关

## 1 特性

- 符合汽车应用 应用认证
- 具有符合 AEC-Q100 标准的下列结果：
  - 器件温度等级 1：环境运行温度范围为 -40°C 至 125°C
  - 器件人体放电模式 (HBM) 静电放电 (ESD) 分类等级 H3A
  - 器件组件充电模式 (CDM) ESD 分类等级 C4B
- 具有丰富诊断功能的四通道 160mΩ 智能高侧开关
  - 版本 A：开漏数字输出
  - 版本 B：电流感测模拟输出
- 宽工作电压范围：3.4V 至 40V
- 超低待机电流：< 500nA
- 高精度电流感测：> 25mA 的负载条件下为 ±15%
- 可使用外部电阻调节电流限值，> 500mA 的负载条件下为 ±15%
- 保护
  - 通过（内部或外部）电流限制实现接地短路保护
  - 具有锁闭选项的热关断以及热调节
  - 感性负载负电压钳位，已优化转换率
  - 失地保护和失电保护
- 诊断
  - 过流和接地短路检测
  - 负载开路和电池短路检测

典型应用电路原理图

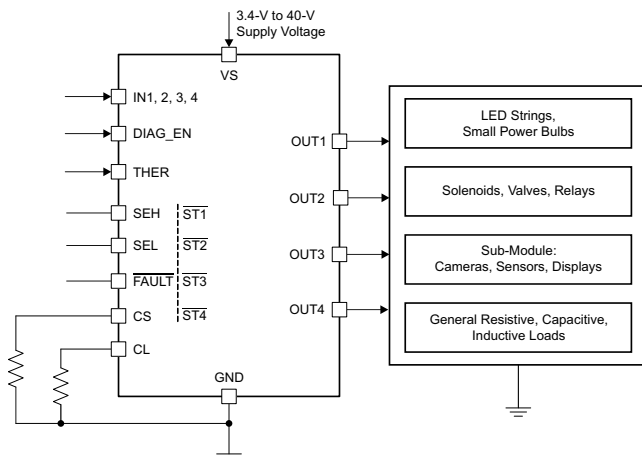

Copyright © 2016, Texas Instruments Incorporated

- 用于实现快速中断的全局故障报告

- 28 引脚耐热增强型 PWP 封装

## 2 应用

- 多通道 LED 驱动器，灯泡驱动器
- 适用于子模块的多通道高侧开关
- 多通道高侧继电器，螺线管驱动器
- 可编程逻辑控制器 (PLC) 数字输出驱动器

## 3 说明

TPS4H160-Q1 器件是一款集成四个 160mΩ N 型金属氧化物半导体 (NMOS) 功率场效应晶体管 (FET) 且受到全方位保护的四通道智能高侧开关。

该器件具有丰富的诊断功能以及高精度电流感测功能，能够对负载实施智能控制。

该器件可从外部调节电流限值以限制浪涌或过载电流，从而提升整个系统的可靠性。

器件信息(1)

| 器件型号             | 封装          | 通道 |
|------------------|-------------|----|
| TPS4H160-Q1 版本 A | HTSSOP (28) | 4  |
| TPS4H160-Q1 版本 B |             |    |

(1) 如需了解所有可用封装，请参阅数据表末尾的可订购产品附录。

驱动具有可调节电流限制的电容性负载

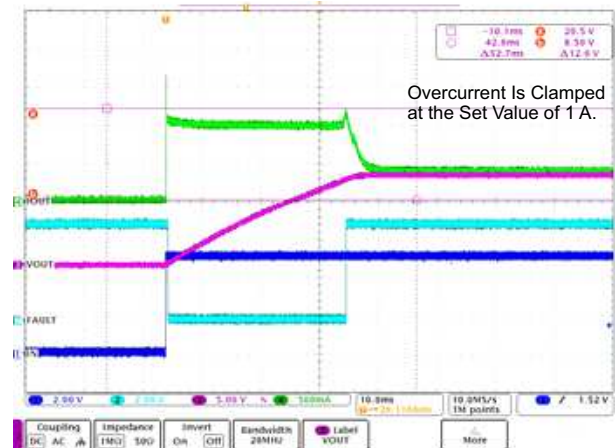

## 目录

|          |  |           |           |   |           |
|----------|--|-----------|-----------|---|-----------|
| <b>1</b> | 特性 .....                                     | <b>1</b>  | 8.3       | Feature Description .....                   | <b>15</b> |
| <b>2</b> | 应用 .....                                     | <b>1</b>  | 8.4       | Device Functional Modes .....               | <b>27</b> |
| <b>3</b> | 说明 .....                                     | <b>1</b>  | <b>9</b>  | <b>Application and Implementation</b> ..... | <b>28</b> |
| <b>4</b> | 修订历史记录 .....                                 | <b>2</b>  | 9.1       | Application Information .....               | <b>28</b> |
| <b>5</b> | <b>Device Comparison Table</b> .....         | <b>3</b>  | 9.2       | Typical Application .....                   | <b>28</b> |
| <b>6</b> | <b>Pin Configuration and Functions</b> ..... | <b>3</b>  | <b>10</b> | <b>Power Supply Recommendations</b> .....   | <b>30</b> |
| <b>7</b> | <b>Specifications</b> .....                  | <b>6</b>  | <b>11</b> | <b>Layout</b> .....                         | <b>31</b> |
| 7.1      | Absolute Maximum Ratings .....               | <b>6</b>  | 11.1      | Layout Guidelines .....                     | <b>31</b> |
| 7.2      | ESD Ratings .....                            | <b>6</b>  | 11.2      | Layout Examples .....                       | <b>31</b> |
| 7.3      | Recommended Operating Conditions .....       | <b>7</b>  | <b>12</b> | 器件和文档支持 .....                               | <b>33</b> |
| 7.4      | Thermal Information .....                    | <b>7</b>  | 12.1      | 接收文档更新通知 .....                              | <b>33</b> |
| 7.5      | Electrical Characteristics .....             | <b>7</b>  | 12.2      | 社区资源 .....                                  | <b>33</b> |
| 7.6      | Switching Characteristics .....              | <b>9</b>  | 12.3      | 商标 .....                                    | <b>33</b> |
| 7.7      | Typical Characteristics .....                | <b>11</b> | 12.4      | 静电放电警告 .....                                | <b>33</b> |
| <b>8</b> | <b>Detailed Description</b> .....            | <b>14</b> | 12.5      | Glossary .....                              | <b>33</b> |
| 8.1      | Overview .....                               | <b>14</b> | <b>13</b> | 机械、封装和可订购信息 .....                           | <b>33</b> |
| 8.2      | Functional Block Diagram .....               | <b>15</b> |           |   |           |

## 4 修订历史记录

### Changes from Revision A (April 2016) to Revision B

**Page**

|   |  |           |
|---|--|-----------|
| • | 在第一页中添加了图示 .....                           | <b>1</b>  |
| • | Changed the functional block diagram ..... | <b>15</b> |
| • | Changed <a href="#">Figure 38</a> .....    | <b>29</b> |
| • | 增加了接收文档更新通知 部分 .....                       | <b>33</b> |

### Changes from Original (December 2015) to Revision A

**Page**

|   |                              |          |
|---|------------------------------|----------|
| • | 已将数据表状态由“产品预览”改为“量产数据” ..... | <b>1</b> |
|---|------------------------------|----------|

## 5 Device Comparison Table

| PART NO.              | FAULT REPORTING MODE        |
|-----------------------|-----------------------------|
| TPS4H160-Q1 Version A | Open-drain digital output   |
| TPS4H160-Q1 Version B | Current-sense analog output |

## 6 Pin Configuration and Functions

**PWP Package**  
**28-Pin HTSSOP With Exposed Thermal Pad**  
**TPS4H160-Q1 Version A Top View**

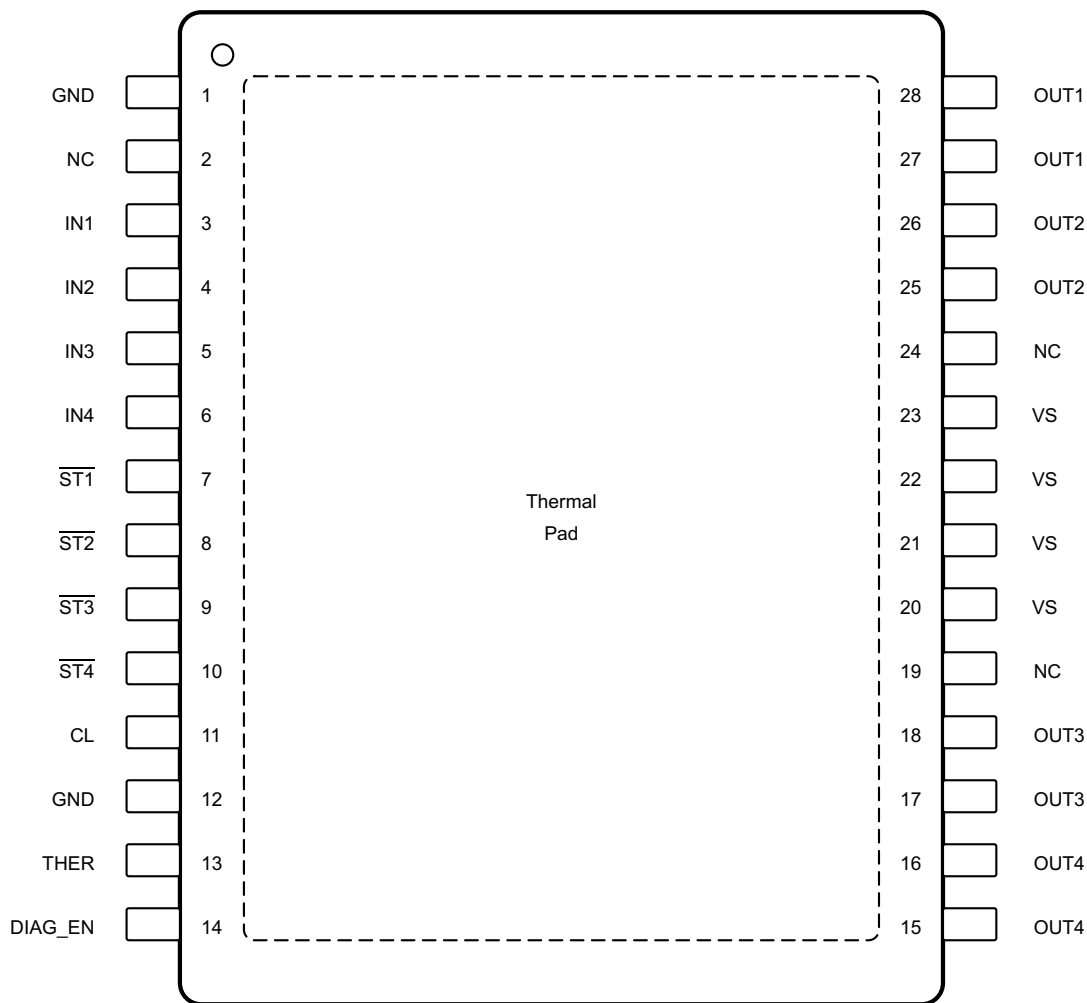

NC – No internal connection

**PWP Package**  
**28-Pin HTSSOP With Exposed Thermal Pad**  
**TPS4H160-Q1 Version B Top View**

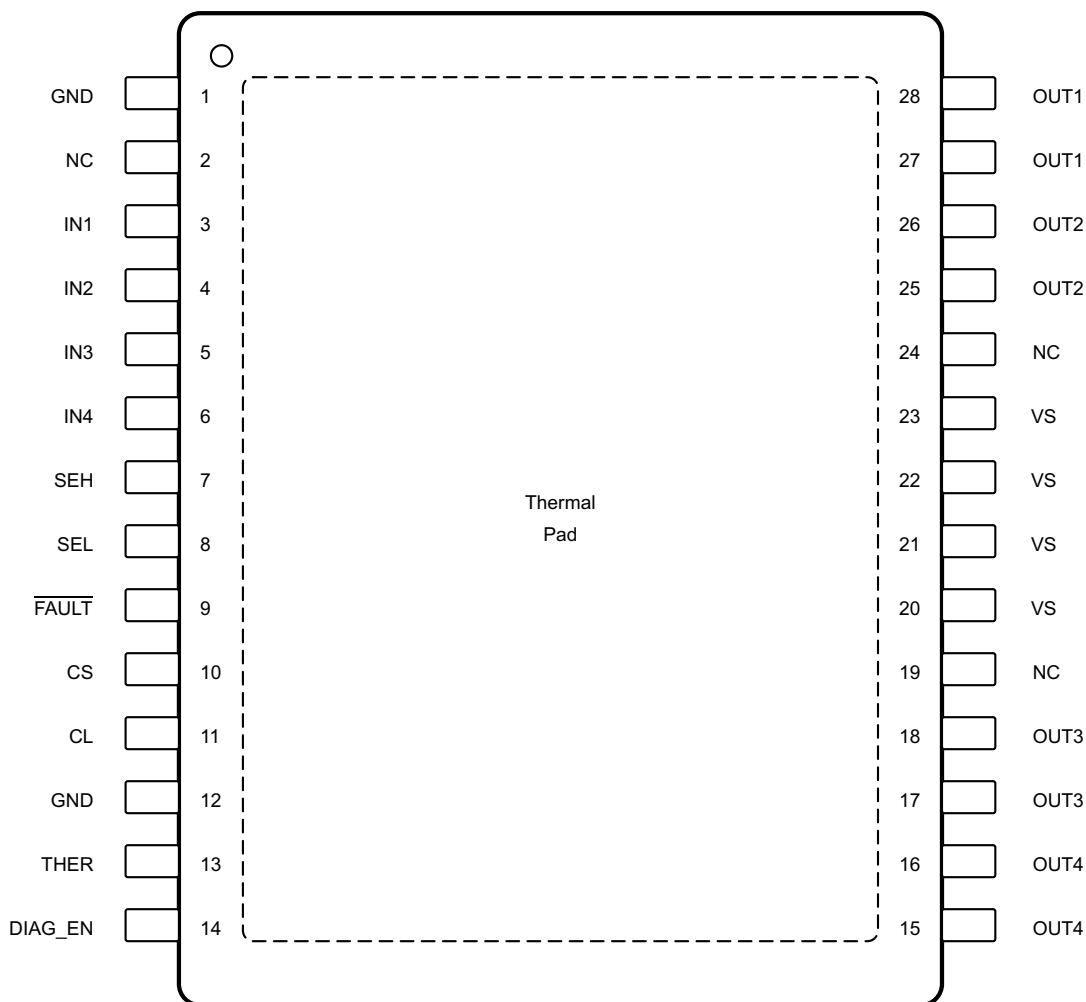

NC – No internal connection

**Pin Functions**

| NAME                      | PIN       |           | I/O | DESCRIPTION   |
|---------------------------|-----------|-----------|-----|---|
|                           | NO.       |           |     |   |
|                           | VERSION A | VERSION B |     |   |
| CL                        | 11        | 11        | O   | Adjustable current limit. Connect to device GND if external current limit is not used.      |
| CS                        | —         | 10        | O   | Current-sense output  |
| DIAG_EN                   | 14        | 14        | I   | Enable-disable pin for diagnostics; internal pull-down                                      |
| $\overline{\text{FAULT}}$ | —         | 9         | O   | Global fault report with open-drain structure, ORed logic for quad-channel fault conditions |
| GND                       | 1, 12     | 1, 12     | —   | Ground pin  |
| IN1                       | 3         | 3         | I   | Input control for channel 1 activation; internal pull-down                                  |
| IN2                       | 4         | 4         | I   | Input control for channel 2 activation; internal pull-down                                  |
| IN3                       | 5         | 5         | I   | Input control for channel 3 activation; internal pull-down                                  |
| IN4                       | 6         | 6         | I   | Input control for channel 4 activation; internal pull-down                                  |
| NC                        | 2, 19, 24 | 2, 19, 24 | —   | No internal connection  |

**Pin Functions (continued)**

| NAME             | PIN               |                   | I/O | DESCRIPTION   |
|------------------|-------------------|-------------------|-----|---|
|                  | NO.               |                   |     |   |
|                  | VERSION A         | VERSION B         |     |   |
| $\overline{ST1}$ | 7                 | —                 | O   | Open-drain diagnostic status output for channel 1                             |
| $\overline{ST2}$ | 8                 | —                 | O   | Open-drain diagnostic status output for channel 2                             |
| $\overline{ST3}$ | 9                 | —                 | O   | Open-drain diagnostic status output for channel 3                             |
| $\overline{ST4}$ | 10                | —                 | O   | Open-drain diagnostic status output for channel 4                             |
| SEH              | —                 | 7                 | I   | CS channel-selection high bit; internal pulldown                              |
| SEL              | —                 | 8                 | I   | CS channel-selection low bit; internal pulldown                               |
| THER             | 13                | 13                | I   | Thermal shutdown behavior control, latch off or auto-retry; internal pulldown |
| OUT1             | 27, 28            | 27, 28            | O   | Output of the channel 1 high side-switch, connected to the load               |
| OUT2             | 25, 26            | 25, 26            | O   | Output of the channel 2 high side-switch, connected to the load               |
| OUT3             | 17, 18            | 17, 18            | O   | Output of the channel 3 high side-switch, connected to the load               |
| OUT4             | 15, 16            | 15, 16            | O   | Output of the channel 4 high side-switch, connected to the load               |
| VS               | 20, 21, 22,<br>23 | 20, 21, 22,<br>23 | I   | Power supply  |
| Thermal pad      | —                 | —                 | —   | Connect to device GND or leave floating                                       |

## 7 Specifications

### 7.1 Absolute Maximum Ratings

over operating ambient temperature range (unless otherwise noted) <sup>(1)(2)</sup>

|   |               | MIN  | MAX | UNIT |
|---|---------------|------|-----|------|
| Supply voltage  | t < 400 ms    |      | 48  | V    |
| Reverse polarity voltage <sup>(3)</sup>   |               | -36  |     | V    |
| Current on GND pin  | t < 2 minutes | -100 | 250 | mA   |
| Voltage on INx, DIAG_EN, SEL, SEH, and THER pins  |               | -0.3 | 7   | V    |
| Current on INx, DIAG_EN, SEL, SEH, and THER pins  |               | -10  | —   | mA   |
| Voltage on $\overline{STx}$ or $\overline{FAULT}$ pins                                    |               | -0.3 | 7   | V    |
| Current on $\overline{STx}$ or $\overline{FAULT}$ pins                                    |               | -30  | 10  | mA   |
| Voltage on CS pin   |               | -2.7 | 7   | V    |
| Current on CS pin   |               | —    | 30  | mA   |
| Voltage on CL pin   |               | -0.3 | 7   | V    |
| Current on CL pin   |               | —    | 6   | mA   |
| Inductive load switch-off energy dissipation, single pulse, single channel <sup>(4)</sup> |               | —    | 40  | mJ   |
| Operating junction temperature  |               | -40  | 150 | °C   |
| Storage temperature, T <sub>stg</sub>   |               | -65  | 150 | °C   |

- (1) Stresses beyond those listed under *Absolute Maximum Ratings* may cause permanent damage to the device. These are stress ratings only, which do not imply functional operation of the device at these or any other conditions beyond those indicated under *Recommended Operating Conditions*. Exposure to absolute-maximum-rated conditions for extended periods may affect device reliability.
- (2) All voltage values are with respect to the ground plane.
- (3) Reverse polarity condition: t < 60 s, reverse current < I<sub>R(2)</sub>, V<sub>INx</sub> = 0 V, all channels reverse, GND pin 1-kΩ resistor in parallel with diode.
- (4) Test condition: V<sub>VS</sub> = 13.5 V, L = 8 mH, R = 0 Ω, T<sub>J</sub> = 150°C. FR4 2s2p board, 2 x 70-μm Cu, 2 x 35-μm Cu. 600 mm<sup>2</sup> thermal pad copper area.

### 7.2 ESD Ratings

|  |   |                                 | VALUE | UNIT |
|--|---|---------------------------------|-------|------|
| V <sub>(ESD)</sub> Electrostatic discharge | Human-body model (HBM), per AEC Q100-002 <sup>(1)</sup> | All pins except VS, OUTx, GND   | ±4000 | V    |
|  |   | Pins VS, OUTx, GND              | ±5000 |      |
|  | Charged-device model (CDM), per AEC Q100-011            | All pins                        | ±750  |      |
|  |   | Corner pins (1, 14, 15, and 28) | ±750  |      |

- (1) AEC Q100-002 indicates that HBM stressing shall be in accordance with the ANSI/ESDA/JEDEC JS-001 specification.

### 7.3 Recommended Operating Conditions

over operating ambient temperature range (unless otherwise noted)

|          |   | MIN | MAX | UNIT |
|----------|---|-----|-----|------|
| $V_{VS}$ | Supply operating voltage                                | 4   | 40  | V    |
|          | Voltage on INx, DIAG_EN, SEL, SEH, and THER pins        | 0   | 5   | V    |
|          | Voltage on $\overline{STx}$ and $\overline{FAULT}$ pins | 0   | 5   | V    |
|          | Nominal dc load current                                 | 0   | 2.5 | A    |
| $T_A$    | Operating ambient temperature range                     | -40 | 125 | °C   |

### 7.4 Thermal Information

| THERMAL METRIC <sup>(1)</sup> |  | TPS4H160-Q1  |  | UNIT |
|-------------------------------|--|--------------|--|------|
|                               |  | PWP (HTSSOP) |  |      |
|                               |  | 28 PINS      |  |      |
| $R_{\theta JA}$               | Junction-to-ambient thermal resistance       | 32.7         |  | °C/W |
| $R_{\theta JC(top)}$          | Junction-to-case (top) thermal resistance    | 17.1         |  | °C/W |
| $R_{\theta JB}$               | Junction-to-board thermal resistance         | 14.4         |  | °C/W |
| $\Psi_{JT}$                   | Junction-to-top characterization parameter   | 0.5          |  | °C/W |
| $\Psi_{JB}$                   | Junction-to-board characterization parameter | 14.3         |  | °C/W |
| $R_{\theta JC(bot)}$          | Junction-to-case (bottom) thermal resistance | 2.1          |  | °C/W |

(1) For more information about traditional and new thermal metrics, see the *IC Package Thermal Metrics* application report, [SPRA953](#).

### 7.5 Electrical Characteristics

5 V <  $V_{VS}$  < 40 V; -40°C <  $T_J$  < 150°C, unless otherwise specified)

| PARAMETER                | TEST CONDITIONS                                      | MIN  | TYP | MAX | UNIT |               |    |    |
|--------------------------|--|--|-----|-----|------|---------------|----|----|
| <b>OPERATING VOLTAGE</b> |  |  |     |     |      |               |    |    |
| $V_{VS(nom)}$            | Nominal operating voltage                            | 4  |     | 40  | V    |               |    |    |
| $V_{VS(uvr)}$            | Undervoltage turnon                                  | $V_{VS}$ rises up  | 3.5 | 3.7 | 4    | V             |    |    |
| $V_{VS(uvf)}$            | Undervoltage shutdown                                | $V_{VS}$ falls down  | 3   | 3.2 | 3.4  | V             |    |    |
| $V_{(uv,hys)}$           | Undervoltage shutdown, hysteresis                    |  | 0.5 |     | V    |               |    |    |
| <b>OPERATING CURRENT</b> |  |  |     |     |      |               |    |    |
| $I_{(op)}$               | Nominal operating current <sup>(1)</sup>             | $V_{VS} = 13.5\text{ V}$ , $V_{INx} = 5\text{ V}$ , $V_{DIAG\_EN} = 0\text{ V}$ , $I_{OUTx} = 0.5\text{ A}$ , current limit = 2 A, all channels on |     |     | 8    | mA            |    |    |
| $I_{(off)}$              | Standby current                                      | $V_{VS} = 13.5\text{ V}$ , $V_{INx} = V_{DIAG\_EN} = V_{CS} = V_{CL} = V_{OUTx} = \text{THER} = 0\text{ V}$ , $T_J = 25^\circ\text{C}$             |     |     | 0.5  | $\mu\text{A}$ |    |    |
|                          |  | $V_{VS} = 13.5\text{ V}$ , $V_{INx} = V_{DIAG\_EN} = V_{CS} = V_{CL} = V_{OUTx} = \text{THER} = 0\text{ V}$ , $T_J = 125^\circ\text{C}$            |     |     | 5    |               |    |    |
| $I_{(off,diag)}$         | Standby current with diagnostic enabled              | $V_{VS} = 13.5\text{ V}$ , $V_{INx} = 0\text{ V}$ , $V_{DIAG\_EN} = 5\text{ V}$ , $V_{VS} - V_{OUTx} > V_{(ol,off)}$ , not in open-load mode       |     |     | 5    | mA            |    |    |
| $t_{(off,diag)}$         | Standby mode deglitch time <sup>(1)</sup>            | IN from high to low, if deglitch time > $t_{(off,deg)}$ , the device enters into standby mode.   |     |     | 10   | 12.5          | 15 | ms |
| $I_{(kg,out)}$           | Output leakage current in off-state                  | $V_{VS} = 13.5\text{ V}$ , $V_{INx} = V_{DIAG\_EN} = V_{OUTx} = 0$   |     |     | 3    | $\mu\text{A}$ |    |    |
| <b>POWER STAGE</b>       |  |  |     |     |      |               |    |    |
| $r_{DS(on)}$             | On-state resistance <sup>(1)</sup>                   | $V_{VS} \geq 3.5\text{ V}$ , $T_J = 25^\circ\text{C}$  |     |     | 165  | m $\Omega$    |    |    |
|                          |  | $V_{VS} \geq 3.5\text{ V}$ , $T_J = 150^\circ\text{C}$   |     |     | 280  |               |    |    |
| $I_{CL(int)}$            | Internal current limit                               | Internal current limit value, CL pin connected to GND  |     |     | 8    | 14            | A  |    |
| $I_{CL(TSD)}$            | Current limit during thermal shutdown <sup>(1)</sup> | Internal current limit value under thermal shutdown  |     |     | 6.5  | A             |    |    |
|                          |  | External current limit value under thermal shutdown. The percentage of the external current limit setting value                                    |     |     | 70%  |               |    |    |
| $V_{DS(clamp)}$          | Drain-to-source internal clamp voltage               | 50   |     | 70  | V    |               |    |    |

(1) Value specified by design, not subject to production test

**Electrical Characteristics (continued)**

 5 V < V<sub>VS</sub> < 40 V; -40°C < T<sub>J</sub> < 150°C, unless otherwise specified)

| PARAMETER  |  | TEST CONDITIONS   | MIN                           | TYP  | MAX                   | UNIT |
|--|--|---|-------------------------------|------|-----------------------|------|
| <b>OUTPUT DIODE CHARACTERISTICS</b>                |  |   |                               |      |                       |      |
| V <sub>F</sub>                                     | Drain-source diode voltage   | IN = 0, I <sub>OUTx</sub> = -0.15 A.  | 0.3                           | 0.7  | 0.9                   | V    |
| I <sub>R(1)</sub> , I <sub>R(2)</sub>              | Continuous reverse current from source to drain <sup>(1)</sup>   | t < 60 s, V <sub>INx</sub> = 0 V, T <sub>J</sub> = 25°C, single channel reversed, short-to-battery condition  |                               | 2.5  |                       | A    |
|  |  | t < 60 s, V <sub>INx</sub> = 0 V, GND pin 1-kΩ resistor in parallel with diode. T <sub>J</sub> = 25°C. Reverse-polarity condition, all channels reversed        |                               | 2    |                       |      |
| <b>LOGIC INPUT (INx, DIAG_EN, SEL, SEH, THER)</b>  |  |   |                               |      |                       |      |
| V <sub>IH</sub>                                    | Logic high-level voltage   |   | 2                             |      |                       | V    |
| V <sub>IL</sub>                                    | Logic low-level voltage  |   |                               |      | 0.8                   | V    |
| R <sub>(logic,pd)</sub>                            | Logic-pin pulldown resistor  | INx, SEL, SEH, THER, V <sub>INx</sub> = V <sub>SEL</sub> = V <sub>SEH</sub> = V <sub>THER</sub> = 5 V   | 100                           | 175  | 250                   | kΩ   |
|  |  | DIAG_EN. V <sub>VS</sub> = V <sub>DIAG_EN</sub> = 5 V   | 200                           | 275  | 350                   |      |
| <b>DIAGNOSTICS</b>                                 |  |   |                               |      |                       |      |
| I <sub>lkg(GND_loss)</sub>                         | Output leakage current under GND loss condition  |   |                               |      | 100                   | μA   |
| V <sub>(ol,off)</sub>                              | Open-load detection threshold  | IN = 0 V, when V <sub>VS</sub> - V <sub>OUTx</sub> < t <sub>(ol,off)</sub> , duration longer than t <sub>(ol,off)</sub> , then open load is detected, off state | 1.6                           |      | 2.6                   | V    |
| t <sub>d(ol,off)</sub>                             | Open-load detection threshold deglitch time (see Figure 3)   | IN = 0 V, when V <sub>VS</sub> - V <sub>OUTx</sub> < V <sub>(ol,off)</sub> , duration longer than t <sub>(ol,off)</sub> , then open load is detected, off state | 300                           | 550  | 800                   | μs   |
| I <sub>(ol,off)</sub>                              | Off-state output sink current  | V <sub>INx</sub> = 0 V, V <sub>DIAG_EN</sub> = 5 V, V <sub>VS</sub> = V <sub>OUTx</sub> = 13.5 V, T <sub>J</sub> = 125°C, open load                             | -75                           |      |                       | μA   |
| V <sub>OL(STx)</sub>                               | Status low-output voltage  | I <sub>STx</sub> = 2 mA, version A only   |                               |      | 0.2                   | V    |
| V <sub>OL(FAULT)</sub>                             | Fault low-output voltage   | I <sub>FAULT</sub> = 2 mA, version B only   |                               |      | 0.2                   | V    |
| t <sub>CL(deg)</sub>                               | Deglitch time when current limit occurs <sup>(1)</sup>   | V <sub>INx</sub> = V <sub>DIAG_EN</sub> = 5 V, the deglitch time from current limit toggling to FAULT, STx, CS report.  | 80                            |      | 180                   | μs   |
| T <sub>(SD)</sub>                                  | Thermal shutdown threshold <sup>(1)</sup>  |   | 160                           | 175  |                       | °C   |
| T <sub>(SD,rst)</sub>                              | Thermal shutdown status reset threshold <sup>(1)</sup>   |   |                               | 155  |                       | °C   |
| T <sub>(SW)</sub>                                  | Thermal swing shutdown threshold <sup>(1)</sup>  |   |                               | 60   |                       | °C   |
| T <sub>(hys)</sub>                                 | Hysteresis for resetting the thermal shutdown or thermal swing <sup>(1)</sup>  |   |                               | 10   |                       | °C   |
| <b>CURRENT SENSE (Version B) AND CURRENT LIMIT</b> |  |   |                               |      |                       |      |
| K <sub>(CS)</sub>                                  | Current-sense ratio  |   |                               | 300  |                       |      |
| K <sub>(CL)</sub>                                  | Current-limit ratio  |   |                               | 2500 |                       |      |
| V <sub>CL(th)</sub>                                | Current limit internal threshold <sup>(1)</sup>  |   |                               | 0.8  |                       | V    |
| dK <sub>(CS)</sub> / K <sub>(CS)</sub>             | Current-sense accuracy, (I <sub>CS</sub> × K <sub>(CS)</sub> - I <sub>OUTx</sub> ) / I <sub>OUTx</sub> × 100                               | V <sub>VS</sub> = 13.5 V, I <sub>OUTx</sub> ≥ 5 mA  | -65%                          |      | 65%                   |      |
|  |  | V <sub>VS</sub> = 13.5 V, I <sub>OUTx</sub> ≥ 25 mA   | -15%                          |      | 15%                   |      |
|  |  | V <sub>VS</sub> = 13.5 V, I <sub>OUTx</sub> ≥ 50 mA   | -8%                           |      | 8%                    |      |
|  |  | V <sub>VS</sub> = 13.5 V, I <sub>OUTx</sub> ≥ 100 mA  | -4%                           |      | 4%                    |      |
|  |  | V <sub>VS</sub> = 13.5 V, I <sub>OUTx</sub> ≥ 0.5 A   | -3%                           |      | 3%                    |      |
| dK <sub>(CL)</sub> / K <sub>(CL)</sub>             | External current limit accuracy, (I <sub>OUTx</sub> - I <sub>CL</sub> × K <sub>(CL)</sub> ) × 100 / (I <sub>CL</sub> × K <sub>(CL)</sub> ) | V <sub>VS</sub> = 13.5 V, I <sub>(limit)</sub> ≥ 0.25 A   | -20%                          |      | 20%                   |      |
|  |  | V <sub>VS</sub> = 13.5 V, 0.5 A ≤ I <sub>(limit)</sub> ≤ 7 A  | -15%                          |      | 15%                   |      |
| V <sub>CS(lin)</sub>                               | Current-sense voltage linear range <sup>(1)</sup>  | V <sub>VS</sub> ≥ 6.5 V   | 0                             |      | 4                     | V    |
|  |  | 5 V ≤ V <sub>VS</sub> < 6.5 V   | 0                             |      | V <sub>VS</sub> - 2.5 |      |
| I <sub>OUTx(lin)</sub>                             | Output-current linear range <sup>(1)</sup>   | V <sub>VS</sub> ≥ 6.5 V, V <sub>CS(lin)</sub> ≤ 4 V   | 0                             |      | 2.5                   | A    |
|  |  | 5 V ≤ V <sub>VS</sub> < 6.5 V, V <sub>CS(lin)</sub> ≤ V <sub>VS</sub> - 2.5 V   | 0                             |      | 2.5                   |      |
| V <sub>CS(H)</sub>                                 | Current sense pin output voltage   | V <sub>VS</sub> ≥ 7 V, fault mode   | 4.5                           |      | 6.5                   | V    |
|  |  | 5 V ≤ V <sub>VS</sub> < 7 V, fault mode   | Min(V <sub>VS</sub> - 2, 4.5) |      | 6.5                   |      |
| I <sub>CS(H)</sub>                                 | Current-sense pin output current   | V <sub>CS</sub> = 4.5 V, V <sub>VS</sub> = 13.5 V   | 15                            |      |                       | mA   |
| I <sub>lkg(CS)</sub>                               | Current-sense leakage current in disabled mode   | V <sub>DIAG_EN</sub> = 0 V, T <sub>J</sub> = 125°C  |                               |      | 0.5                   | μA   |



## 7.6 Switching Characteristics

| PARAMETER  |  | TEST CONDITIONS  | MIN | TYP | MAX  | UNIT                   |
|--|--|--|-----|-----|------|------------------------|
| $t_{d(on)}$  | Delay time, $V_{OUTx}$ 10% after $V_{INx}$ ↑ (See Figure 1.) | $V_{VS} = 13.5\text{ V}$ , $V_{DIAG\_EN} = 5\text{ V}$ , $I_{OUTx} = 0.5\text{ A}$ , IN rising edge to 10% of $V_{OUTx}$   | 20  | 50  | 90   | $\mu\text{s}$          |
| $t_{d(off)}$   | Delay time, $V_{OUTx}$ 90% after $V_{INx}$ ↓ (See Figure 1.) | $V_{VS} = 13.5\text{ V}$ , $V_{DIAG\_EN} = 5\text{ V}$ , $I_{OUTx} = 0.5\text{ A}$ , IN falling edge to 90% of $V_{OUTx}$  | 20  | 50  | 90   | $\mu\text{s}$          |
| $dV/dt(on)$  | Turnon slew rate   | $V_{VS} = 13.5\text{ V}$ , $V_{DIAG\_EN} = 5\text{ V}$ , $I_{OUTx} = 0.5\text{ A}$ , $V_{OUTx}$ from 10% to 90%  | 0.1 | 0.3 | 0.55 | $\text{V}/\mu\text{s}$ |
| $dV/dt(off)$   | Turnoff slew rate  | $V_{VS} = 13.5\text{ V}$ , $V_{DIAG\_EN} = 5\text{ V}$ , $I_{OUTx} = 0.5\text{ A}$ , $V_{OUTx}$ from 90% to 10%  | 0.1 | 0.3 | 0.55 | $\text{V}/\mu\text{s}$ |
| $t_{d(match)}$                                       | $t_{d(rise)} - t_{d(fall)}$ (See Figure 1.)                  | $V_{VS} = 13.5\text{ V}$ , $I_L = 0.5\text{ A}$ . $t_{d, rise}$ is the IN rising edge to $V_{OUTx} = 90\%$ . $t_{d(fall)}$ is the IN falling edge to $V_{OUTx} = 10\%$ . | -50 |     | 50   | $\mu\text{s}$          |
| <b>CURRENT-SENSE CHARACTERISTICS (See Figure 2.)</b> |  |  |     |     |      |                        |
| $t_{CS(off1)}$                                       | CS settling time from DIAG_EN disabled <sup>(1)</sup>        | $V_{VS} = 13.5\text{ V}$ , $V_{INx} = 5\text{ V}$ , $I_{OUTx} = 0.5\text{ A}$ . current limit = 2 A. DIAG_EN falling edge to 10% of $V_{CS}$ .                           |     |     | 20   | $\mu\text{s}$          |
| $t_{CS(on1)}$  | CS settling time from DIAG_EN enabled <sup>(1)</sup>         | $V_{VS} = 13.5\text{ V}$ , $V_{INx} = 5\text{ V}$ , $I_{OUTx} = 0.5\text{ A}$ . current limit is 2 A. DIAG_EN rising edge to 90% of $V_{CS}$ .                           |     |     | 20   | $\mu\text{s}$          |
| $t_{CS(off2)}$                                       | CS settling time from IN falling edge                        | $V_{VS} = 13.5\text{ V}$ , $V_{DIAG\_EN} = 5\text{ V}$ , $I_{OUTx} = 0.5\text{ A}$ . current limit = 2 A. IN falling edge to 10% of $V_{CS}$                             | 30  |     | 100  | $\mu\text{s}$          |
| $t_{CS(on2)}$  | CS settling time from IN rising edge                         | $V_{VS} = 13.5\text{ V}$ , $V_{DIAG\_EN} = 5\text{ V}$ , $I_{OUTx} = 0.5\text{ A}$ . current limit = 2 A. IN rising edge to 90% of $V_{CS}$                              | 50  |     | 150  | $\mu\text{s}$          |
| $t_{SEx}$  | Multi-sense transition delay from channel to channel         | $V_{DIAG\_EN} = 5\text{ V}$ , current sense output delay when multi-sense pins SEL and SEH transition from channel to channel  |     |     | 50   | $\mu\text{s}$          |

(1) Value specified by design, not subject to production test

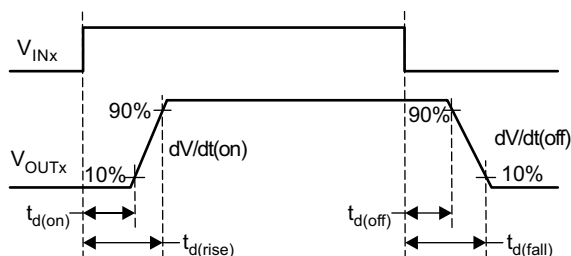

Figure 1. Output Delay Characteristics

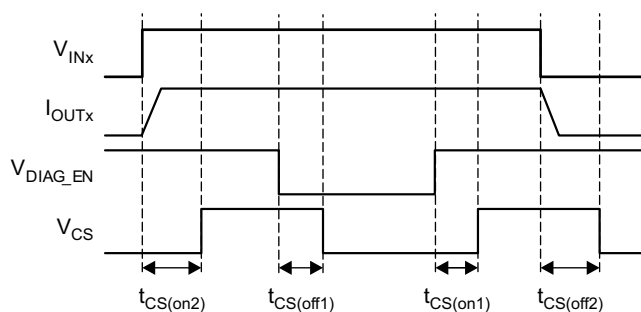
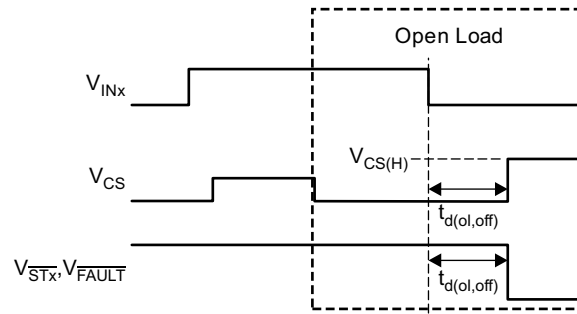
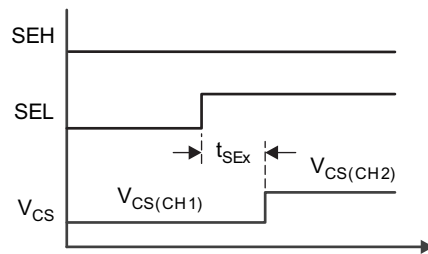

Figure 2. CS Delay Characteristics

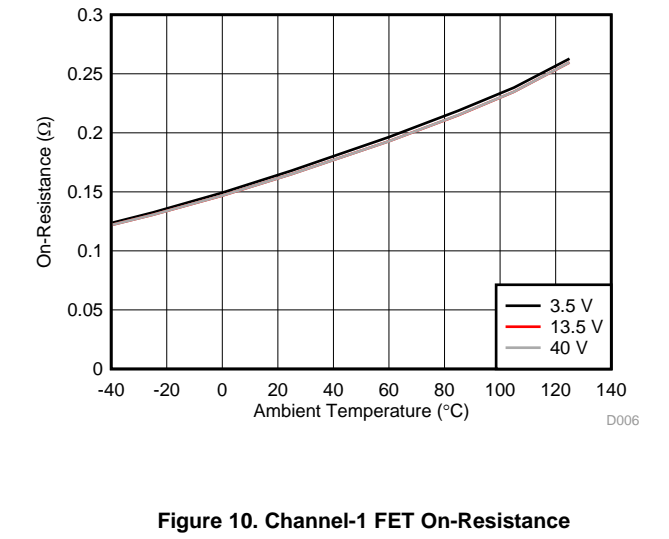
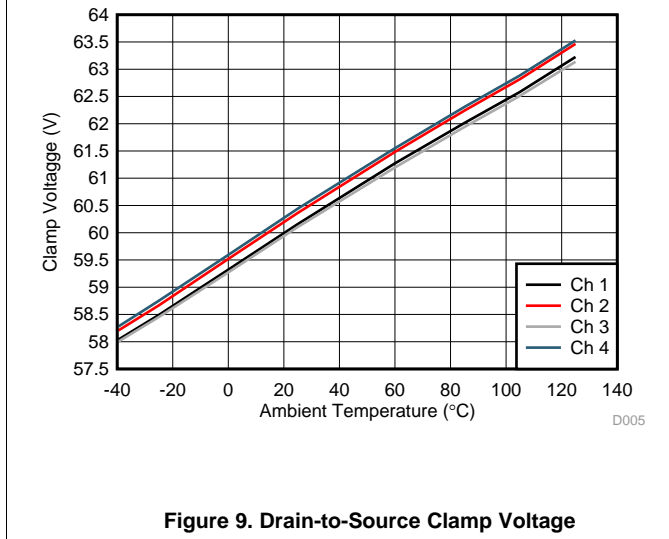
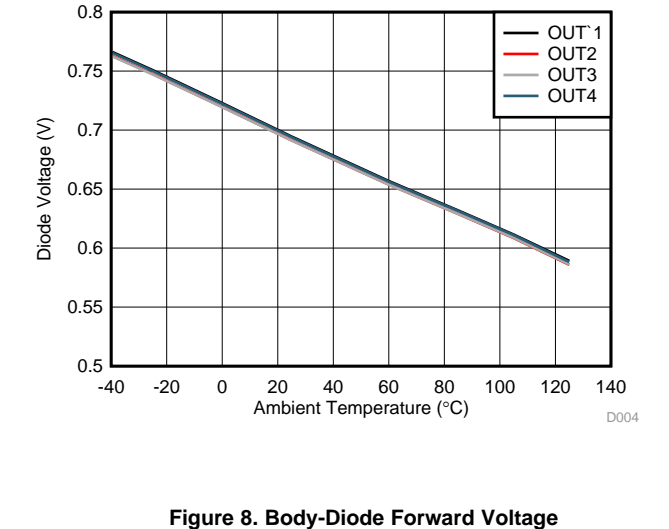
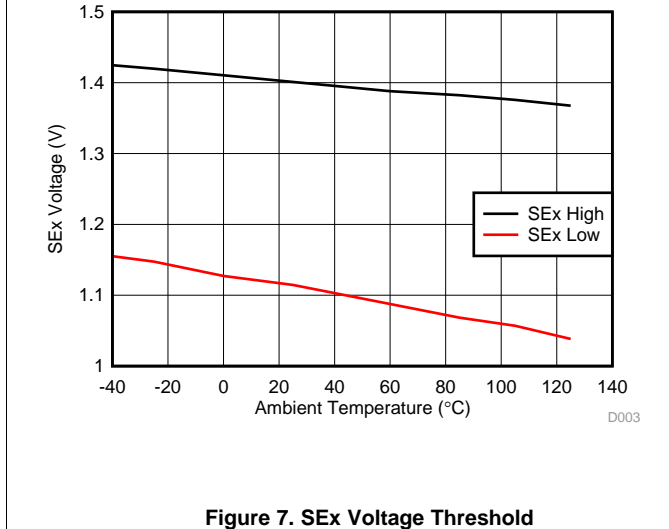
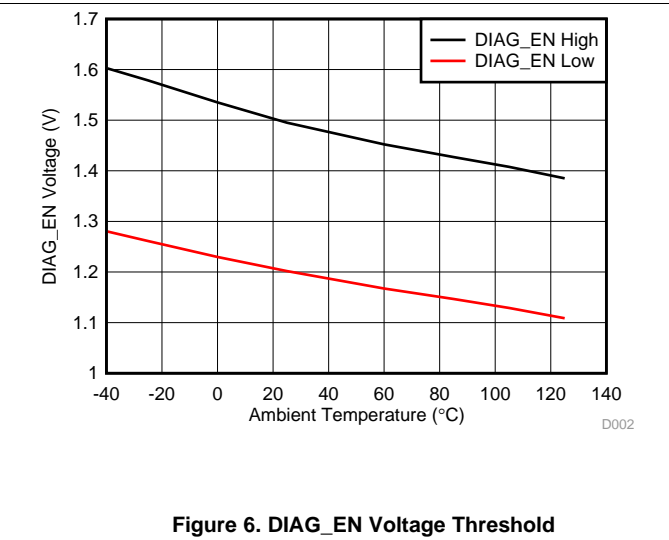
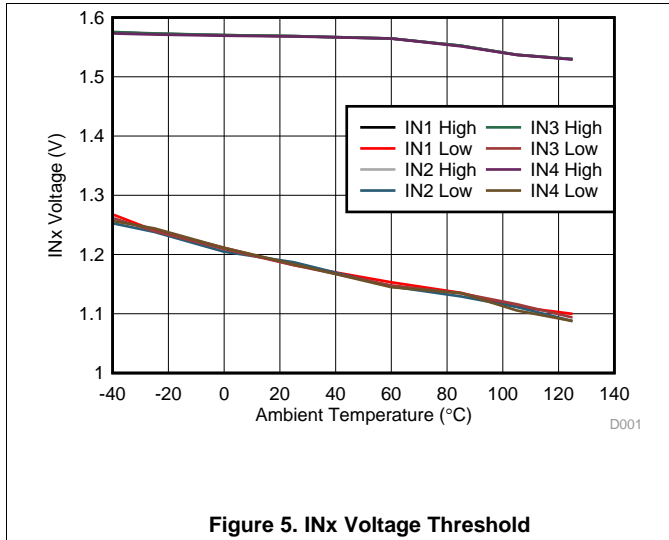

**Figure 3. Open-Load Blanking-Time Characteristics**



**Figure 4. Multi-Sense Transition Delay**

7.7 Typical Characteristics



Typical Characteristics (continued)

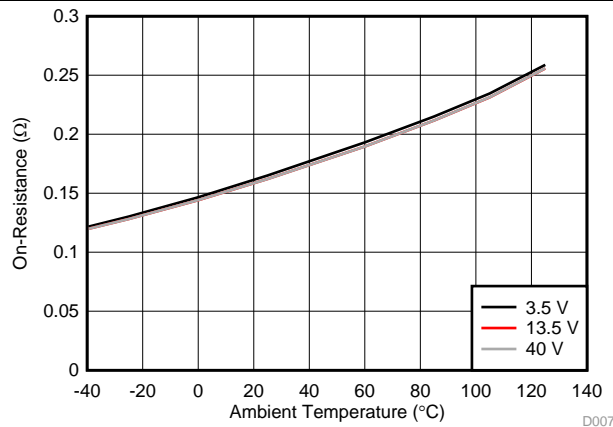

Figure 11. Channel-2 FET On-Resistanc

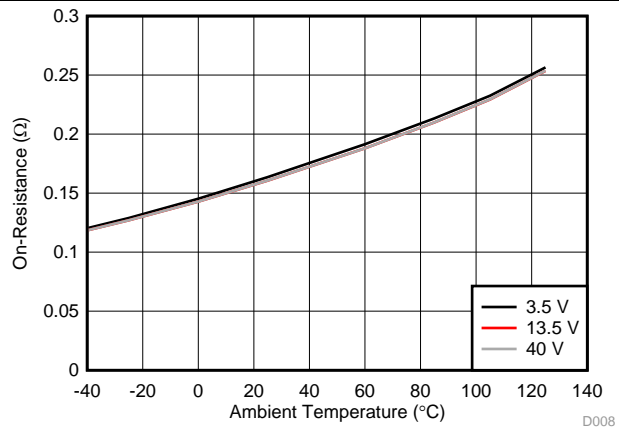

Figure 12. Channel-3 FET On-Resistanc

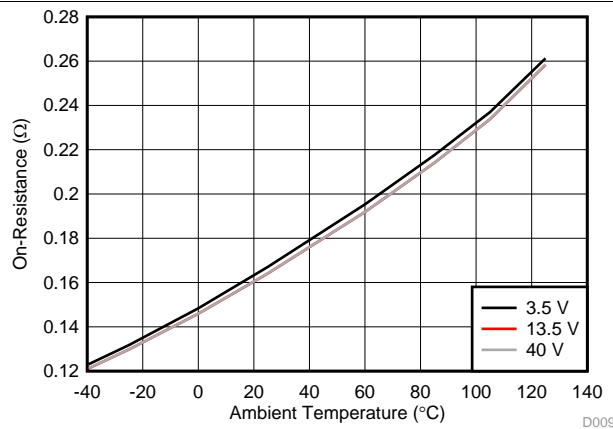

Figure 13. Channel-4 FET On-Resistanc

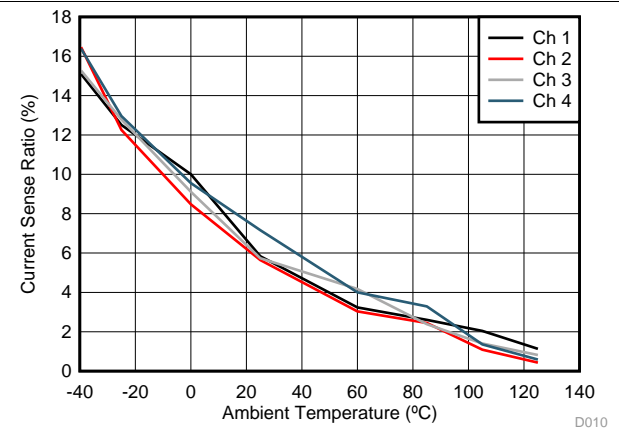

Figure 14. Current-Sense Ratio at 5 mA

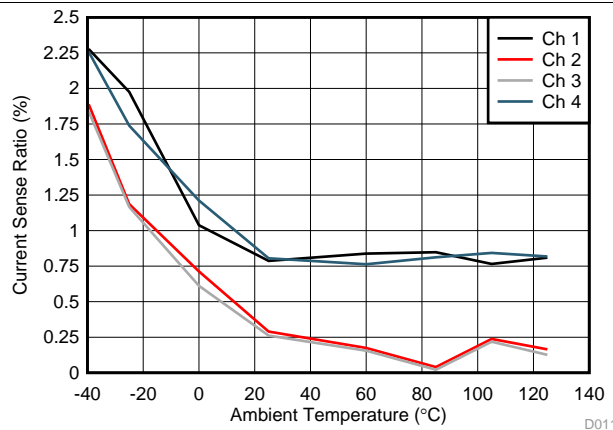

Figure 15. Current-Sense Ratio at 25 mA

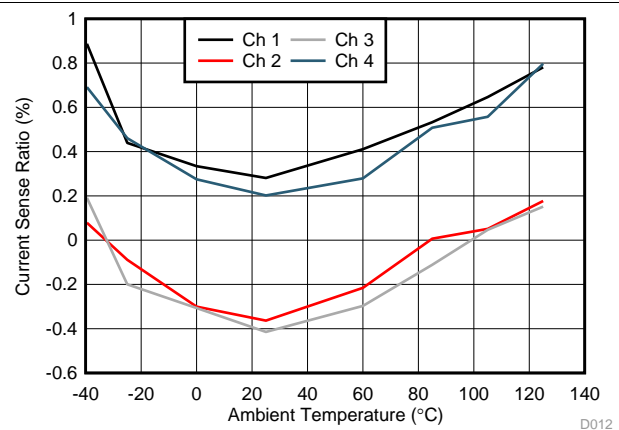
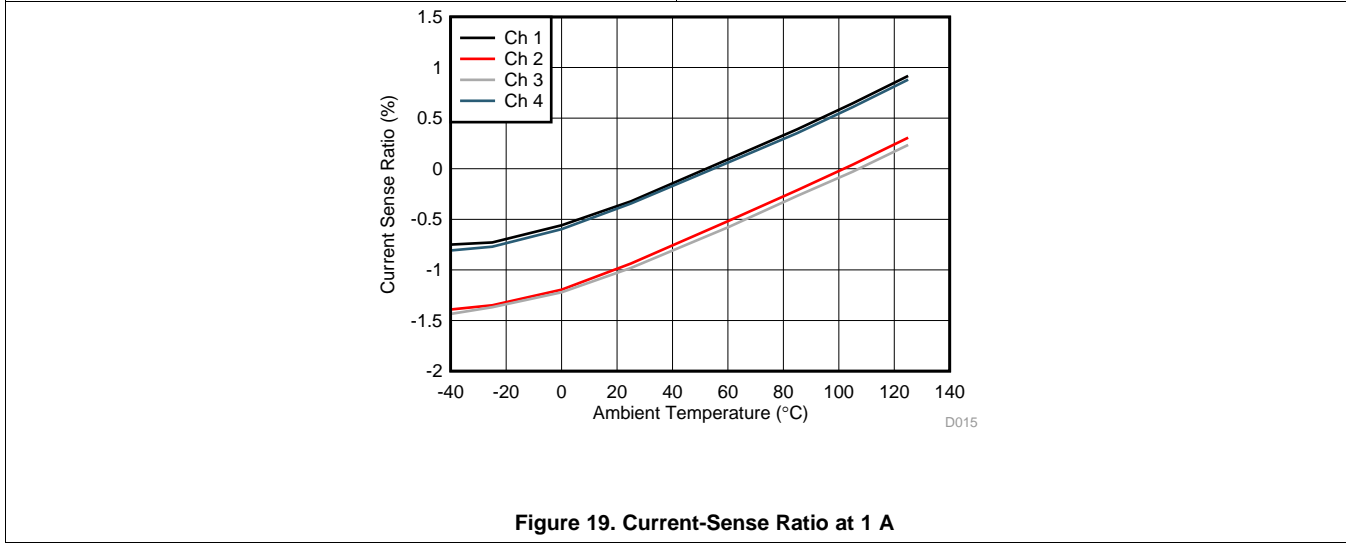
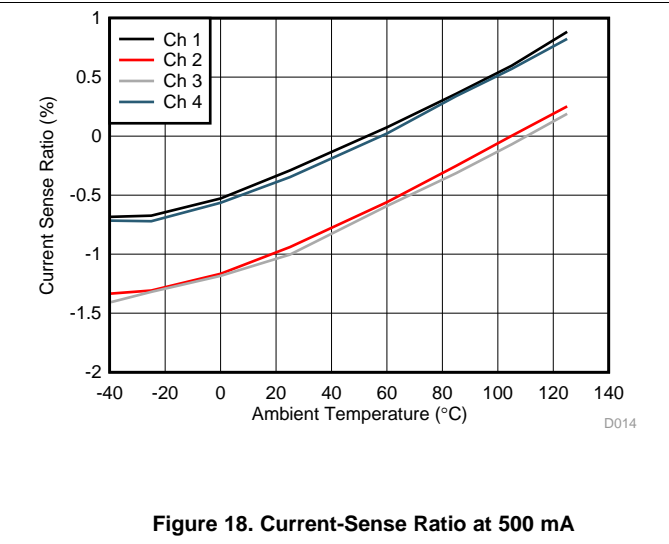
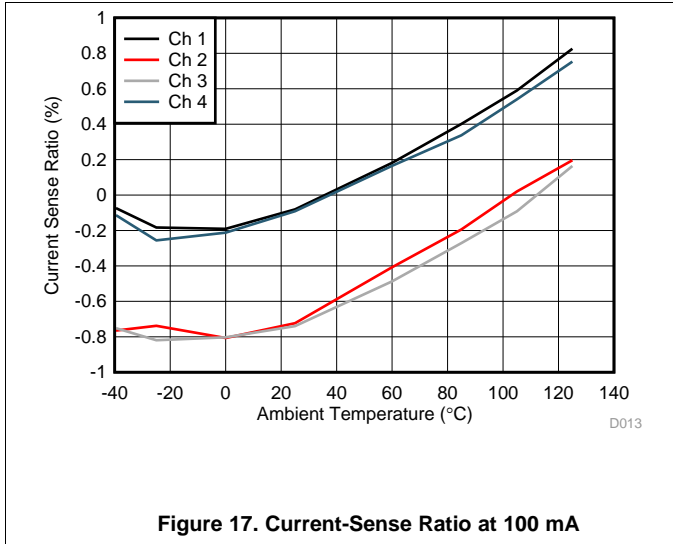

Figure 16. Current-Sense Ratio at 50 mA

Typical Characteristics (continued)



## 8 Detailed Description

### 8.1 Overview

The TPS4H160-Q1 device is a smart high-side switch, with internal charge pump and quad-channel integrated NMOS power FETs. Full diagnostics and high-accuracy current-sense features enable intelligent control of the load. The adjustable current-limit function greatly improves the reliability of whole system. The device has two versions with different diagnostic reporting, the open-drain digital output (version A) and the current-sense analog output (version B).

For version A, the device implements the digital fault report with an open-drain structure. When a fault occurs, the device pulls  $\overline{STx}$  down to GND. A 3.3- or 5-V external pullup is required to match the microcontroller supply level. The digital status of each channel can report individually, or globally by connecting the  $\overline{STx}$  pins together.

For version B, high-accuracy current sense makes the diagnostics more accurate without further calibration. One integrated current mirror can source  $1 / K_{(CS)}$  of the load current. The mirrored current flows into the CS-pin resistor to become a voltage signal.  $K_{(CS)}$  is a constant value across temperature and supply voltage. A wide linear region from 0 V to 4 V allows a better real-time load-current monitoring. The CS pin can also report a fault with pullup voltage of  $V_{CS(H)}$ .

The external high-accuracy current limit allows setting the current-limit value by applications. When overcurrent occurs, the device improves system reliability by clamping the inrush current effectively. The device can also save system cost by reducing the size of PCB traces and connectors, and the capacity of the preceding power stage. Besides, the device also implements an internal current limit with a fixed value.

For inductive loads (relays, solenoids, valves), the device implements an active clamp between drain and source to protect itself. During the inductive switching-off cycle, both the energy of the power supply and the load are dissipated on the high-side switch. The device also optimizes the switching-off slew rate when the clamp is active, which helps the system design by keeping the effects of transient power and EMI to a minimum.

The TPS4H160-Q1 device is a smart high-side switch for a wide variety of resistive, inductive, and capacitive loads, including low-wattage bulbs, LEDs, relays, solenoids, heaters, and sub-modules.

## 8.2 Functional Block Diagram

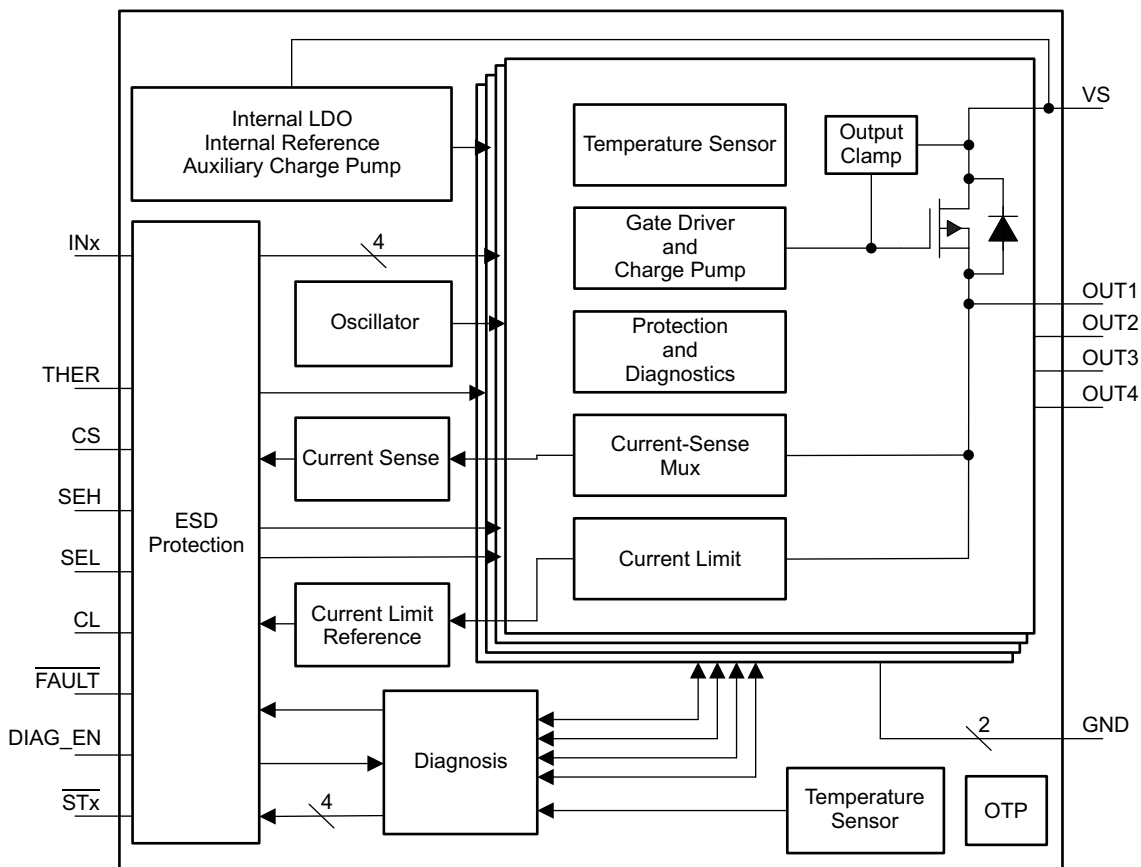

Copyright © 2016, Texas Instruments Incorporated

## 8.3 Feature Description

### 8.3.1 Pin Current and Voltage Conventions

For reference purposes throughout the data sheet, current directions on their respective pins are as shown by the arrows in Figure 20. All voltages are measured relative to the ground plane.

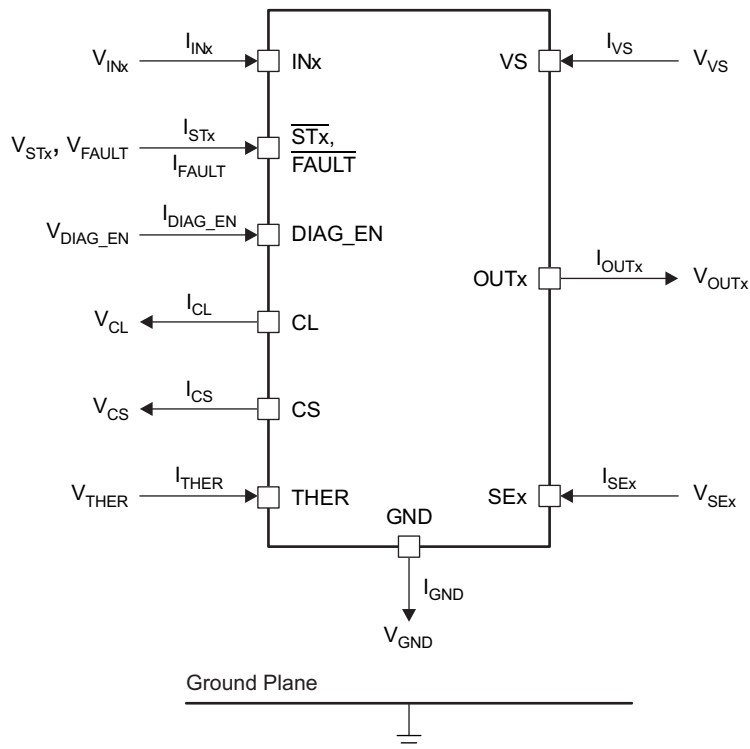
**Feature Description (continued)**

Copyright © 2016, Texas Instruments Incorporated

**Figure 20. Voltage and Current Conventions**
**8.3.2 Accurate Current Sense**

High-accuracy current sense is implemented in the version-B device. It allows a better real-time monitoring effect and more-accurate diagnostics without further calibration.

One integrated current mirror can source  $1 / K_{(CS)}$  of the load current, and the mirrored current flows into the external current sense resistor to become a voltage signal. The current mirror is shared by the four channels.  $K_{(CS)}$  is the ratio of the output current and the sense current. It is a constant value across the temperature and supply voltage. Each device is calibrated accurately during production, so post-calibration is not required. See [Figure 21](#) for more details.



Feature Description (continued)

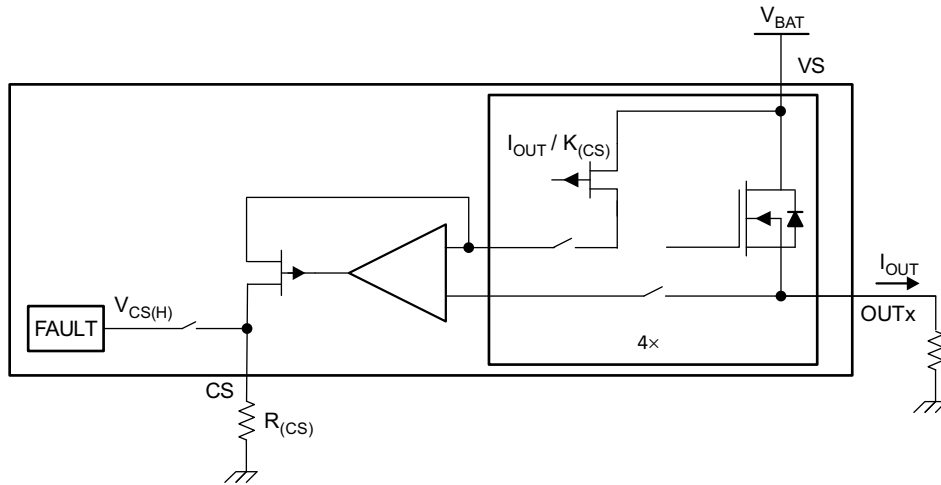

Copyright © 2016, Texas Instruments Incorporated

Figure 21. Current-Sense Block Diagram

When a fault occurs, the CS pin also works as a fault report with a pullup voltage,  $V_{CS(H)}$ . See Figure 22 for more details.

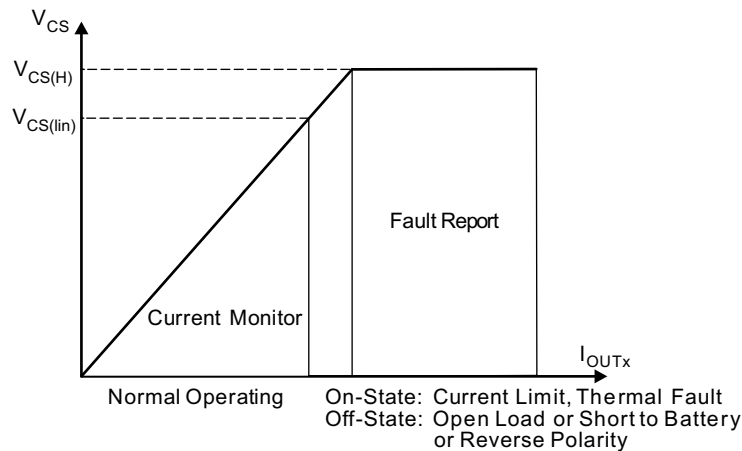

Figure 22. Current-Sense Output-Voltage Curve

Use Equation 1 to calculate  $R_{(CS)}$ .

$$R_{(CS)} = \frac{V_{CS}}{I_{CS}} = \frac{V_{CS} \times K_{(CS)}}{I_{OUTx}} \quad (1)$$

Take the following points into consideration when calculating  $R_{(CS)}$ .

- Ensure  $V_{CS}$  is within the current-sense linear region ( $V_{CS}$ ,  $I_{OUTx(lin)}$ ) across the full range of the load current. Check  $R_{(CS)}$  with Equation 2.

$$R_{(CS)} = \frac{V_{CS}}{I_{CS}} \leq \frac{V_{CS(lin)}}{I_{CS}} \quad (2)$$

- In fault mode, ensure  $I_{CS}$  is within the source capacity of the CS pin ( $I_{CS(H)}$ ). Check  $R_{(CS)}$  with Equation 3.

$$R_{(CS)} = \frac{V_{CS}}{I_{CS}} \geq \frac{V_{CS(H,min)}}{I_{CS(H,min)}} \quad (3)$$

## Feature Description (continued)

### 8.3.3 Adjustable Current Limit

A high-accuracy current limit allows high reliability of the design. It protects the load and the power supply from overstressing during short-circuit-to-GND or power-up conditions. The current limit can also save system cost by reducing the size of PCB traces and connectors, and the capacity of the preceding power stage.

When a current-limit threshold is hit, a closed loop activates immediately. The output current is clamped at the set value, and a fault is reported out. The device heats up due to the high power dissipation on the power FET. If thermal shutdown occurs, the current limit is set to  $I_{CL(TSD)}$  to reduce the power dissipation on the power FET. See [Figure 23](#) for more details.

The device has two current-limit thresholds.

- **Internal current limit** – The internal current limit is fixed at  $I_{CL(int)}$ . Tie the CL pin directly to the device GND for large-transient-current applications.
- **External adjustable current limit** – An external resistor is used to set the current-limit threshold. Use the [Equation 4](#) to calculate the  $R_{(CL)}$ .  $V_{CL(th)}$  is the internal band-gap voltage.  $K_{(CL)}$  is the ratio of the output current and the current-limit set value. It is constant across the temperature and supply voltage. The external adjustable current limit allows the flexibility to set the current limit value by applications.

$$I_{CL} = \frac{V_{CL(th)}}{R_{(CL)}} = \frac{I_{OUT}}{K_{(CL)}}$$

$$R_{(CL)} = \frac{V_{CL(th)} \times K_{(CL)}}{I_{OUT}}$$

(4)

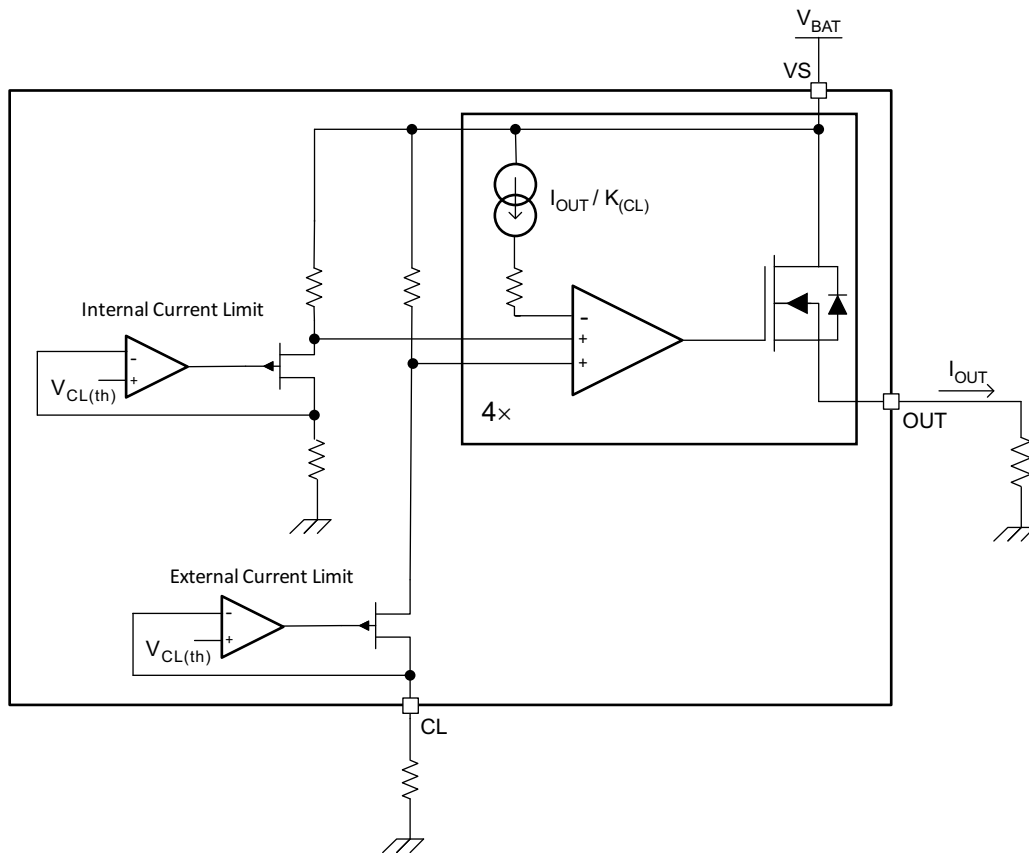

Copyright © 2016, Texas Instruments Incorporated

**Figure 23. Current-Limit Block Diagram**

## Feature Description (continued)

Note that if using a GND network which causes a level shift between the device GND and board GND, the CL pin must be connected with device GND.

For better protection from a hard short-to-GND condition (when the INx pins are enabled, a short to GND occurs suddenly), the device implements a fast-trip protection to turn off the related channel before the current-limit closed loop is set up. The fast-trip response time is less than 1  $\mu$ s, typically. With this fast response, the device can achieve better inrush current-suppression performance.

### 8.3.4 Inductive-Load Switching-Off Clamp

When switching an inductive load off, the inductive reactance tends to pull the output voltage negative. Excessive negative voltage could cause the power FET to break down. To protect the power FET, an internal clamp between drain and source is implemented, namely  $V_{DS(\text{clamp})}$ .

$$V_{DS(\text{clamp})} = V_{VS} - V_{OUT} \quad (5)$$

During the period of demagnetization ( $t_{\text{decay}}$ ), the power FET is turned on for inductance-energy dissipation. The total energy is dissipated in the high-side switch. Total energy includes the energy of the power supply ( $E_{(VS)}$ ) and the energy of the load ( $E_{(\text{load})}$ ). If resistance is in series with inductance, some of the load energy is dissipated on the resistance.

$$E_{(\text{HSS})} = E_{(VS)} + E_{(\text{load})} = E_{(VS)} + E_{(L)} - E_{(R)} \quad (6)$$

When an inductive load switches off,  $E_{(\text{HSS})}$  causes high thermal stressing on the device.. The upper limit of the power dissipation depends on the device intrinsic capacity, ambient temperature, and board dissipation condition.

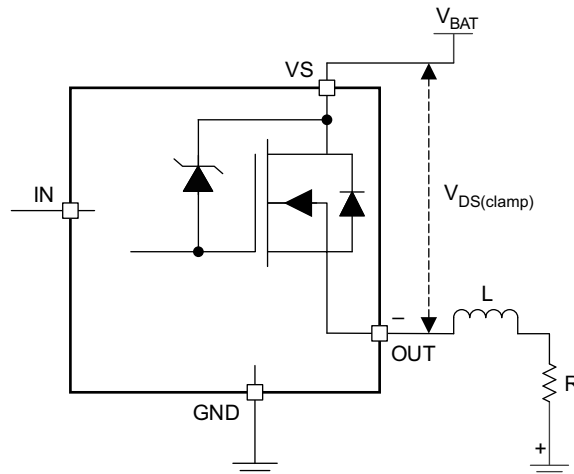

Copyright © 2016, Texas Instruments Incorporated

Figure 24. Drain-to-Source Clamping Structure

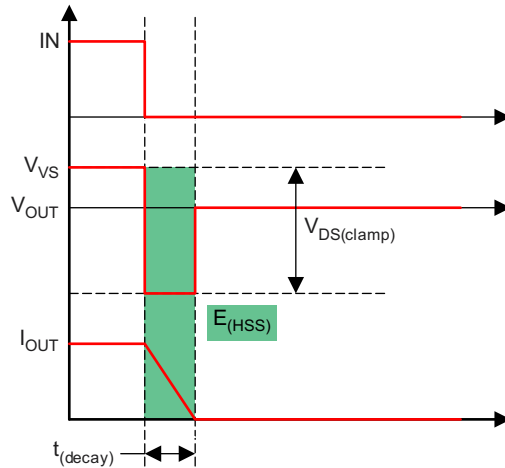
**Feature Description (continued)**

**Figure 25. Inductive Load Switching-Off Diagram**

From the perspective of the high-side switch,  $E_{(HSS)}$  equals the integration value during the demagnetization period.

$$E_{(HSS)} = \int_0^{t_{(decay)}} V_{DS(clamp)} \times I_{OUT}(t) dt$$

$$t_{(decay)} = \frac{L}{R} \times \ln \left( \frac{R \times I_{OUT(max)} + |V_{OUT}|}{|V_{OUT}|} \right)$$

$$E_{(HSS)} = L \times \frac{V_{VS} + |V_{OUT}|}{R^2} \times \left[ R \times I_{OUT(max)} - |V_{OUT}| \ln \left( \frac{R \times I_{OUT(max)} + |V_{OUT}|}{|V_{OUT}|} \right) \right] \quad (7)$$

When  $R$  approximately equals 0,  $E_{(HSD)}$  can be given simply as:

$$E_{(HSS)} = \frac{1}{2} \times L \times I_{OUT(max)}^2 \frac{V_{VS} + |V_{OUT}|}{|V_{OUT}|} \quad (8)$$

Figure 26 is a waveform of the device driving an inductive load, and Figure 27 is waveform with an expanded time scale. Channel 1 is the IN signal, channel 2 is the supply voltage  $V_{VS}$ , channel 3 is the output voltage  $V_{OUT}$ , channel 4 is the output current  $I_{OUT}$ , and channel M is the measured power dissipation  $E_{(HSS)}$ .

On the waveform, the duration of  $V_{OUT}$  from  $V_{VS}$  to  $(V_{VS} - V_{DS(clamp)})$  is around 120  $\mu$ s. The device also optimizes the switching-off slew rate when the clamp is active. This optimization can help the system design by keeping the effects of transient power and EMI to a minimum. As shown in Figure 26 and Figure 27, the controlled slew rate is around 0.5 V/ $\mu$ s.

Feature Description (continued)

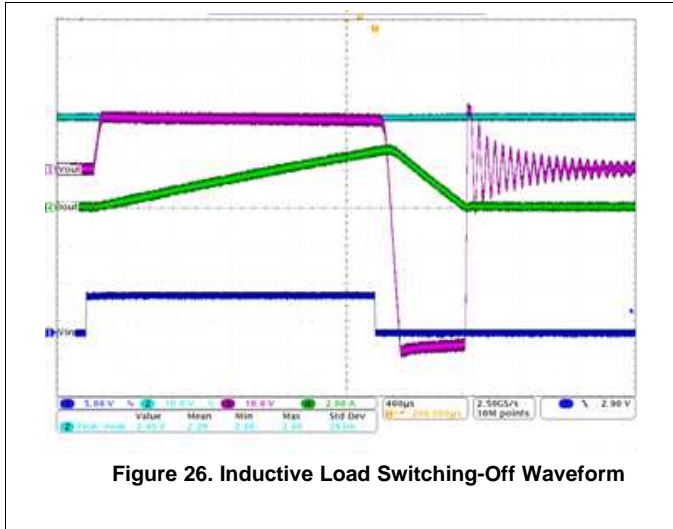

Figure 26. Inductive Load Switching-Off Waveform

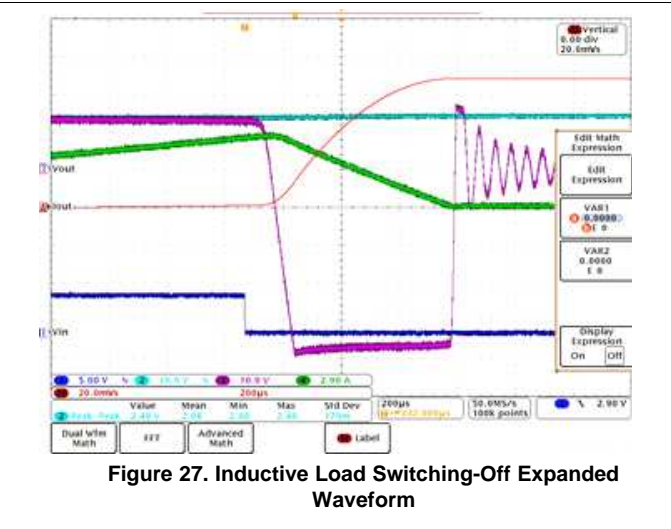
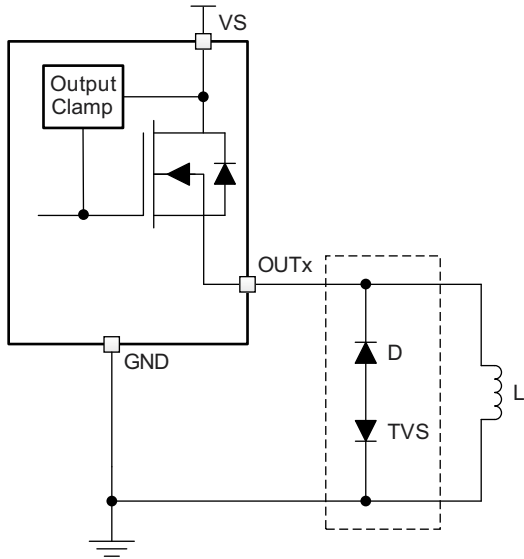

Figure 27. Inductive Load Switching-Off Expanded Waveform

Note that for PWM-controlled inductive loads, it is recommended to add the external freewheeling circuitry shown in Figure 28 to protect the device from repetitive power stressing. TVS is used to achieve the fast decay. See Figure 28 for more details.



Copyright © 2016, Texas Instruments Incorporated

Figure 28. Protection With External Circuitry

8.3.5 Fault Detection and Reporting

8.3.5.1 Diagnostic Enable Function

The DIAG\_EN pin enables or disables the diagnostic functions. If multiple devices are used, but the ADC resource is limited in the microcontroller, the MCU can use GPIOs to set DIAG\_EN high to enable the diagnostics of one device while disabling the diagnostics of the other devices by setting DIAG\_EN low. In addition, the device can keep the power consumption to a minimum by setting DIAG\_EN and INx low.

8.3.5.2 Multiplexing of Current Sense

For version B, SEL and SEH are two pins to multiplex the shared current-sense function among the four channels. See Table 1 for more details.

**Feature Description (continued)**
**Table 1. Diagnosis Configuration Table**

| DIAG_EN | INx | SEH | SEL | CS ACTIVATED CHANNEL | CS, $\overline{\text{FAULT}}$ , $\overline{\text{STx}}$ | PROTECTIONS AND DIAGNOSTICS           |
|---------|-----|-----|-----|----------------------|---|---------------------------------------|
| L       | H   | —   | —   | —                    | High impedance  | Diagnostics disabled, full protection |
|         | L   |     |     |                      |   | Diagnostics disabled, no protection   |
| H       | —   | 0   | 0   | Channel 1            | See <a href="#">Table 2</a>                             | See <a href="#">Table 2</a>           |
|         |     | 0   | 1   | Channel 2            |   |                                       |
|         |     | 1   | 0   | Channel 3            |   |                                       |
|         |     | 1   | 1   | Channel 4            |   |                                       |

**8.3.5.3 Fault Table**

[Table 2](#) applies when the DIAG\_EN pin is enabled.

**Table 2. Fault Table**

| CONDITIONS  | INx | OUTx | THER | CRITERION   | $\overline{\text{STx}}$<br>(VER. A) | CS<br>(VER. B)     | $\overline{\text{FAULT}}$<br>(VER. B) | FAULT RECOVERY   |
|---|-----|------|------|---|-------------------------------------|--------------------|---------------------------------------|--|
| Normal  | L   | L    | —    | —   | H                                   | 0                  | H                                     | —  |
|   | H   | H    | —    | —   | H                                   | In linear region   | H                                     | —  |
| Overload, short to ground                                     | H   | L    | —    | Current limit triggered                                 | L                                   | $V_{\text{CS(H)}}$ | L                                     | Auto   |
| Open load <sup>(1)</sup> , short to battery, reverse polarity | L   | H    | —    | $V_{\text{VS}} - V_{\text{OUTx}} < V_{\text{(ol,off)}}$ | L                                   | $V_{\text{CS(H)}}$ | L                                     | Auto   |
| Thermal shutdown  | H   | —    | L    | $T_{\text{SD}}$ triggered                               | L                                   | $V_{\text{CS(H)}}$ | L                                     | Output auto-retry. Fault recovers when $T_{\text{J}} < T_{\text{(SD,rst)}}$ or when INx toggles. |
|   |     |      | H    |   |                                     |                    |                                       | Output latch off. Fault recovers when INx toggles.   |
| Thermal swing   | H   | —    | —    | $T_{\text{SW}}$ triggered                               | L                                   | $V_{\text{CS(H)}}$ | L                                     | Auto   |

(1) An external pullup is required for open-load detection.

**8.3.5.4  $\overline{\text{STx}}$  and  $\overline{\text{FAULT}}$  Reporting**

For version A, four individual  $\overline{\text{STx}}$  pins report the fault conditions, each pin for its respective channel. When a fault condition occurs, it pulls  $\overline{\text{STx}}$  down to GND. A 3.3- or 5-V external pullup is required to match the supply level of the microcontroller. The digital status of each channel can be reported individually, or globally by connecting all the  $\overline{\text{STx}}$  pins together.

For version B, a global  $\overline{\text{FAULT}}$  pin is used to monitor the global fault condition among all the channels. When a fault condition occurs on any channel, the  $\overline{\text{FAULT}}$  pin is pulled down to GND. A 3.3-V or 5-V external pullup is required to match the supply level of the microcontroller.

After the  $\overline{\text{FAULT}}$  report, the microcontroller can check and identify the channel in fault status by multiplexed current sensing. The CS pin also works as a fault report with an internal pullup voltage,  $V_{\text{CS(H)}}$ .

**8.3.6 Full Diagnostics**
**8.3.6.1 Short-to-GND and Overload Detection**

When a channel is on, a short to GND or overload condition causes overcurrent. If the overcurrent triggers either the internal or external current-limit threshold, the fault condition is reported out. The microcontroller can handle the overcurrent by turning off the switch. The device heats up if no actions are taken. If a thermal shutdown occurs, the current limit is  $I_{\text{CL(TSD)}}$  to keep the power stressing on the power FET to a minimum. The device automatically recovers when the fault condition is removed.

### 8.3.6.2 Open-Load Detection

#### 8.3.6.2.1 Channel On

When a channel on, benefiting from the high-accuracy current sense in a small current range, if an open-load event occurs, it can be detected as an ultralow  $V_{CS}$  and handled by the microcontroller. Note that the detection is not reported on the  $\overline{STx}$  or  $\overline{FAULT}$  pins. The microcontroller must multiplex the SEL and SEH pins to detect the channel-on open-load fault proactively.

#### 8.3.6.2.2 Channel Off

When a channel is off, if a load is connected, the output is pulled down to GND. But if an open load occurs, the output voltage is close to the supply voltage ( $V_{VS} - V_{OUTx} < V_{(ol,off)}$ ), and the fault is reported out.

There is always a leakage current  $I_{(ol,off)}$  present on the output due to internal logic control path or external humidity, corrosion, and so forth. Thus, TI recommends an external pullup resistor to offset the leakage current when an open load is detected. The recommended pullup resistance is 20 k $\Omega$ .

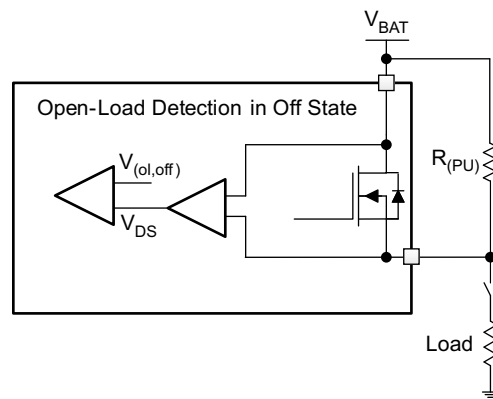

Copyright © 2016, Texas Instruments Incorporated

Figure 29. Open-Load Detection in Off-State

### 8.3.6.3 Short-to-Battery Detection

Short-to-battery has the same detection mechanism and behavior as open-load detection, in both the on-state and off-state. See [Table 2](#) for more details.

In the on-state, reverse current flows through the FET instead of the body diode, leading to less power dissipation. Thus, the worst case occurs in the off-state.

- If  $V_{OUTx} - V_{VS} < V_{(F)}$  (body diode forward voltage), no reverse current occurs.
- If  $V_{OUTx} - V_{VS} > V_{(F)}$ , reverse current occurs. The current must be limited to less than  $I_{R(1)}$ . Setting an INx pin high can minimize the power stress on its channel. Also, for external reverse protection, see [Reverse-Current Protection](#) for more details.

### 8.3.6.4 Reverse Polarity Detection

Reverse polarity detection has the same detection mechanism and behavior as open-load detection both in the on-state and off-state. See [Table 2](#) for more details.

In the on-state, the reverse current flows through the FET instead of the body diode, leading to less power dissipation. Thus, the worst case occurs in the off-state. The reverse current must be limited to less than  $I_{R(2)}$ . Set the related INx pin high to keep the power dissipation to a minimum. For external reverse-blocking circuitry, see [Reverse-Current Protection](#) for more details.

### 8.3.6.5 Thermal Fault Detection

To protect the device in severe power stressing cases, the device implements two types of thermal fault detection, absolute temperature protection (thermal shutdown) and dynamic temperature protection (thermal swing). Respective temperature sensors are integrated close to each power FET, so the thermal fault is reported by each channel. This arrangement can help the device keep the cross-channel effect to a minimum when some channels are in a thermal fault condition.

#### 8.3.6.5.1 Thermal Shutdown

Thermal shutdown is active when the absolute temperature  $T_J > T_{(SD)}$ . When the thermal shutdown occurs, the respective output turns off. The THER pin is used to configure the behavior after the thermal shutdown occurs.

- When the THER pin is low, thermal shutdown operates in the auto-retry mode. The output automatically recovers when  $T_J < T_{(SD)} - T_{(hys)}$ , but the current is limited to  $I_{CL(TSD)}$  to avoid repetitive thermal shutdown. The thermal shutdown fault signal is cleared when  $T_J < T_{(SD,rst)}$  or after toggling the related INx pin.
- When the THER pin is high, thermal shutdown operates in the latch mode. The output latches off when thermal shutdown occurs. When the THER pin goes from high to low, thermal shutdown changes to auto-retry mode. The thermal shutdown fault signal is cleared after toggling the related INx pin.

Thermal swing activates when the power FET temperature is increasing sharply, that is, when  $\Delta T = T_{(FET)} - T_{(Logic)} > T_{(sw)}$ , then the output turns off. The output automatically recovers and the fault signal clears when  $\Delta T = T_{(FET)} - T_{(Logic)} < T_{(sw)} - T_{(hys)}$ . Thermal swing function improves the device reliability when subjected to repetitive fast thermal variation. As shown in Figure 30, multiple thermal swings are triggered before thermal shutdown occurs.

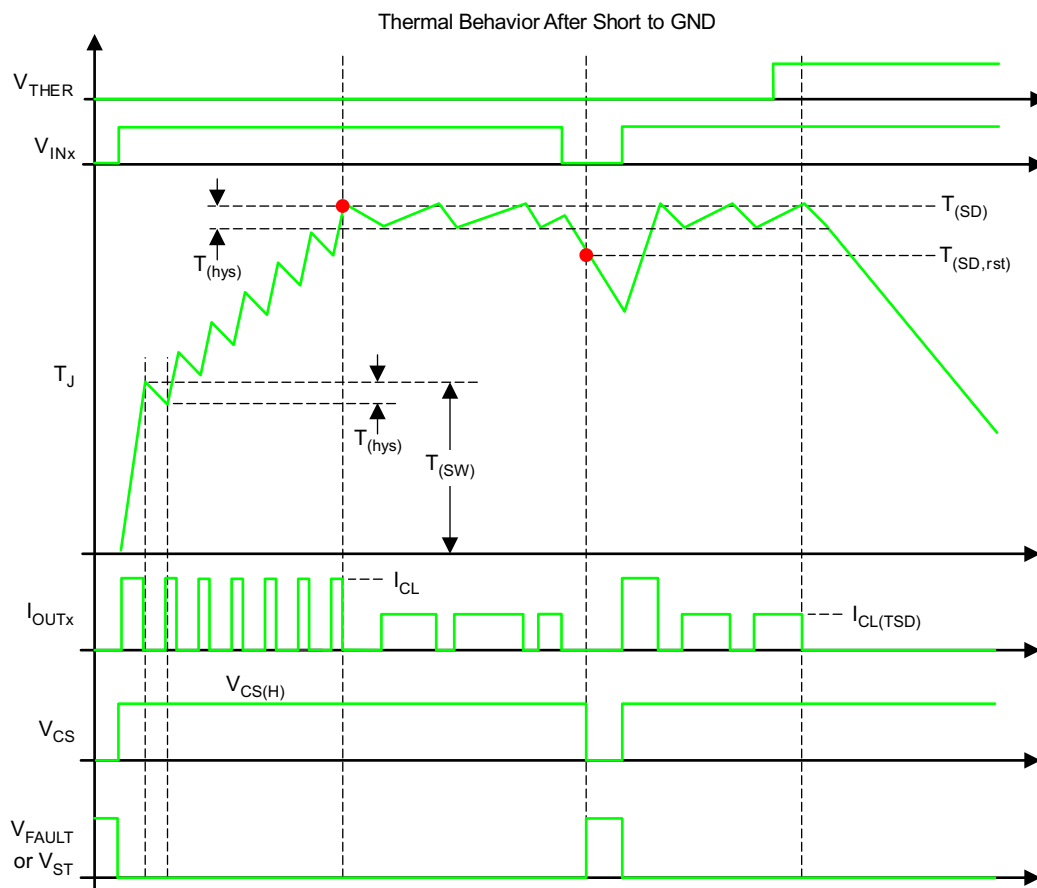

**Figure 30. Thermal Behavior Diagram**



### 8.3.7 Full Protections

#### 8.3.7.1 UVLO Protection

The device monitors the supply voltage  $V_{VS}$ , to prevent unpredicted behaviors when  $V_{VS}$  is too low. When  $V_{VS}$  falls down to  $V_{VS(uvf)}$ , the device shuts down. When  $V_{VS}$  rises up to  $V_{VS(uvr)}$ , the device turns on.

#### 8.3.7.2 Loss-of-GND Protection

When loss of GND occurs, output is shut down regardless of whether the INx pin is high or low. The device can protect against two ground-loss conditions, loss of device GND and loss of module GND.

#### 8.3.7.3 Protection for Loss of Power Supply

When loss of supply occurs, the output is shut down regardless of whether the INx pin is high or low. For a resistive or a capacitive load, loss of supply has no risk. But for a charged inductive load, the current is driven from all the I/O pinss to maintain the inductance current. To protect the system in this condition, TI recommends two types of external protections: the GND network or the external free-wheeling diode.

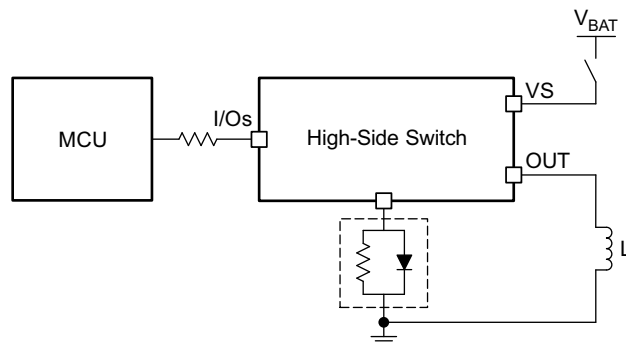

Copyright © 2016, Texas Instruments Incorporated

Figure 31. Protection for Loss of Power Supply, Method 1

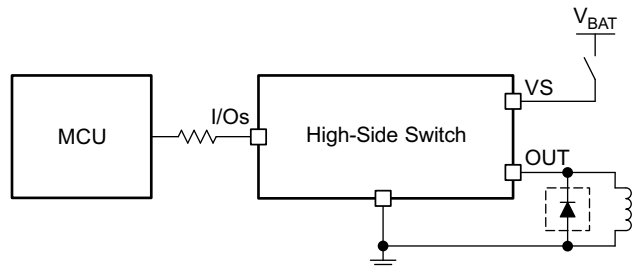

Copyright © 2016, Texas Instruments Incorporated

Figure 32. Protection for Loss of Power Supply, Method 2

#### 8.3.7.4 Reverse-Current Protection

Reverse current occurs in two conditions: short to battery and reverse polarity.

- When a short to the battery occurs, there is only reverse current through the body diode.  $I_{R(1)}$  specifies the limit of the reverse current.
- In a reverse-polarity condition, there are reverse currents through the body diode and the device GND pin.  $I_{R(2)}$  specifies the limit of the reverse current. The GND pin maximum current is specified in the [Absolute Maximum Ratings](#).

To protect the device, TI recommends two types of external circuitry.

- Adding a blocking diode. Both the IC and load are protected when in reverse polarity.

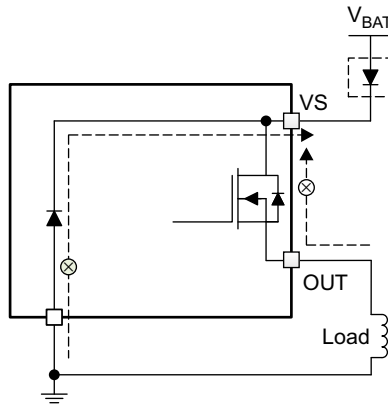

Copyright © 2016, Texas Instruments Incorporated

**Figure 33. Reverse-Current External Protection, Method 1**

- Adding a GND network. The reverse current through the device GND is blocked. The reverse current through the FET is limited by the load itself. TI recommends a resistor in parallel with the diode as a GND network. The recommended selection are 1-k $\Omega$  resistor in parallel with an >100-mA diode. If multiple high-side switches are used, the resistor and diode can be shared among devices.

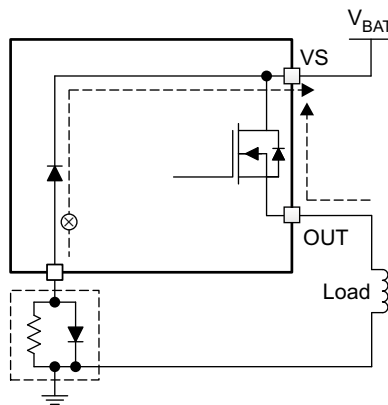

Copyright © 2016, Texas Instruments Incorporated

**Figure 34. Reverse-Current External Protection, Method 2**

### 8.3.7.5 MCU I/O Protection

In some severe conditions, such as the ISO7637-2 test or the loss of battery with inductive loads, a negative pulse occurs on the GND pin. This pulse can cause damage on the connected microcontroller. TI recommends serial resistors to protect the microcontroller, for example, 4.7-k $\Omega$  when using a 3.3-V microcontroller and 10-k $\Omega$  for a 5-V microcontroller.

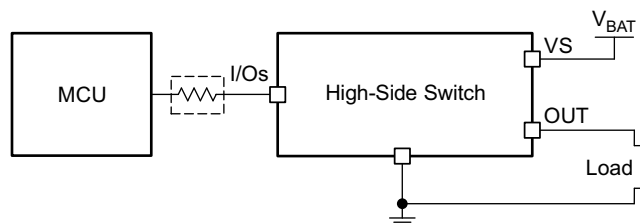

Copyright © 2016, Texas Instruments Incorporated

**Figure 35. MCU I/O External Protection**

## 8.4 Device Functional Modes

### 8.4.1 Working Modes

The device has three working modes, the normal mode, the standby mode, and the standby mode with diagnostics.

Note that IN must be low for  $t > t_{(off,deg)}$  to enter the standby mode, where  $t_{(off,deg)}$  is the standby mode deglitch time used to avoid false triggering. Figure 36 shows a working-mode diagram.

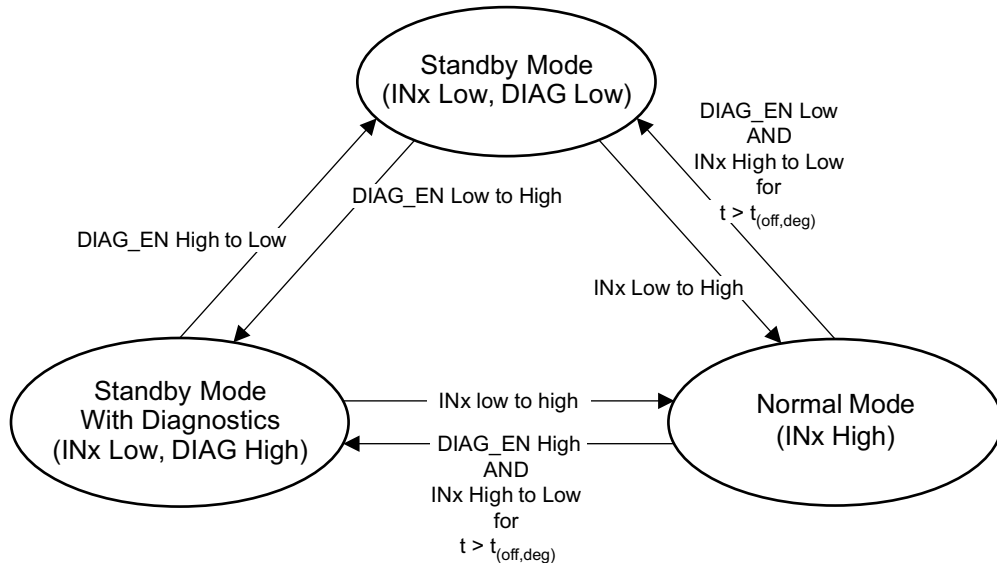

Figure 36. Working Modes

## 9 Application and Implementation

### NOTE

Information in the following applications sections is not part of the TI component specification, and TI does not warrant its accuracy or completeness. TI's customers are responsible for determining suitability of components for their purposes. Customers should validate and test their design implementation to confirm system functionality.

### 9.1 Application Information

The TPS4H160-Q1 device is capable of driving a wide variety of resistive, inductive, and capacitive loads, including the low-wattage bulbs, LEDs, relays, solenoids, heaters, and sub-modules. Full diagnostics and high-accuracy current-sense features enable intelligent control of the load. An external adjustable current limit improves the reliability of the whole system by clamping the inrush or overload current.

### 9.2 Typical Application

The following figure shows an example of the external circuitry connections based on the version-B device.

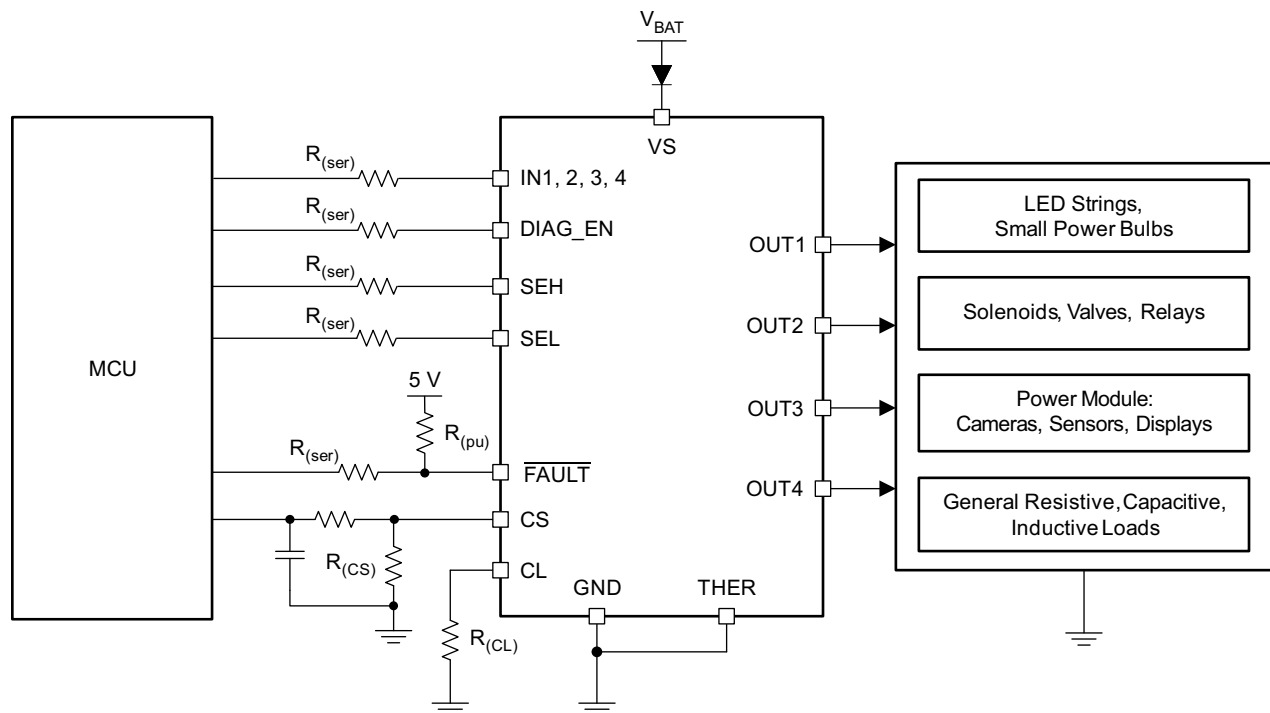

Copyright © 2016, Texas Instruments Incorporated

**Figure 37. Typical Application Diagram**

#### 9.2.1 Design Requirements

- $V_{VS}$  range from 9 V to 16 V
- Load range is from 0.1 A to 1 A for each channel
- Current sense for fault monitoring
- Expected current-limit value of 2.5 A
- Automatic recovery mode when thermal shutdown occurs
- Full diagnostics with 5-V MCU
- Reverse-voltage protection with a blocking diode in the power-supply line

## Typical Application (continued)

### 9.2.2 Detailed Design Procedure

To keep the 1-A nominal current in the 0 to 4-V current-sense range, calculate the  $R_{(CS)}$  resistor using Equation 9. To achieve better current-sense accuracy, a 1% tolerance or better resistor is preferred.

$$R_{(CS)} = \frac{V_{CS}}{I_{CS}} = \frac{V_{CS} \times K_{(CS)}}{I_{OUT}} = \frac{4 \times 300}{1} = 1200 \Omega \tag{9}$$

To set the adjustable current limit value at 2.5-A, calculate  $R_{(CL)}$  using Equation 10.

$$R_{(CL)} = \frac{V_{CL(th)} \times K_{(CL)}}{I_{OUT}} = \frac{0.8 \times 2500}{2.5} = 800 \Omega \tag{10}$$

TI recommends  $R_{(ser)} = 10 \text{ k}\Omega$  for 5-V MCU, and  $R_{(pu)} = 10 \text{ k}\Omega$  as the pullup resistor.

### 9.2.3 Application Curves

Figure 38 shows a test example of soft-start when driving a big capacitive load. Figure 39 shows an expanded waveform of the output current.

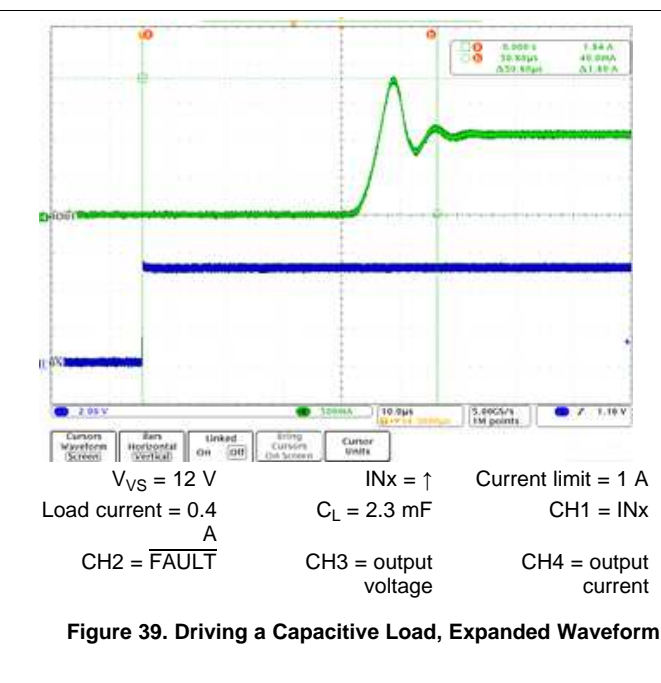
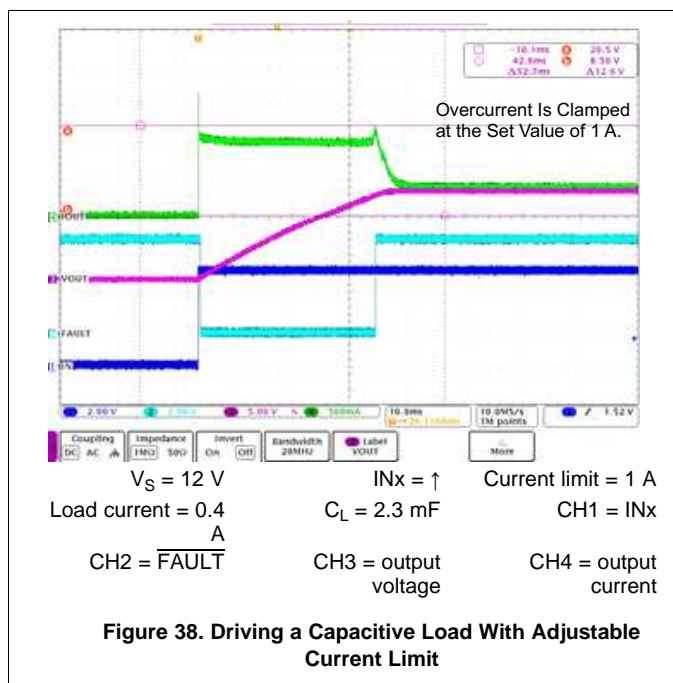

Typical Application (continued)

Figure 40 shows a test example of PWM-mode driving. Figure 41 shows the expanded waveform of the rising edge. Figure 42 shows the expanded waveform of the falling edge.

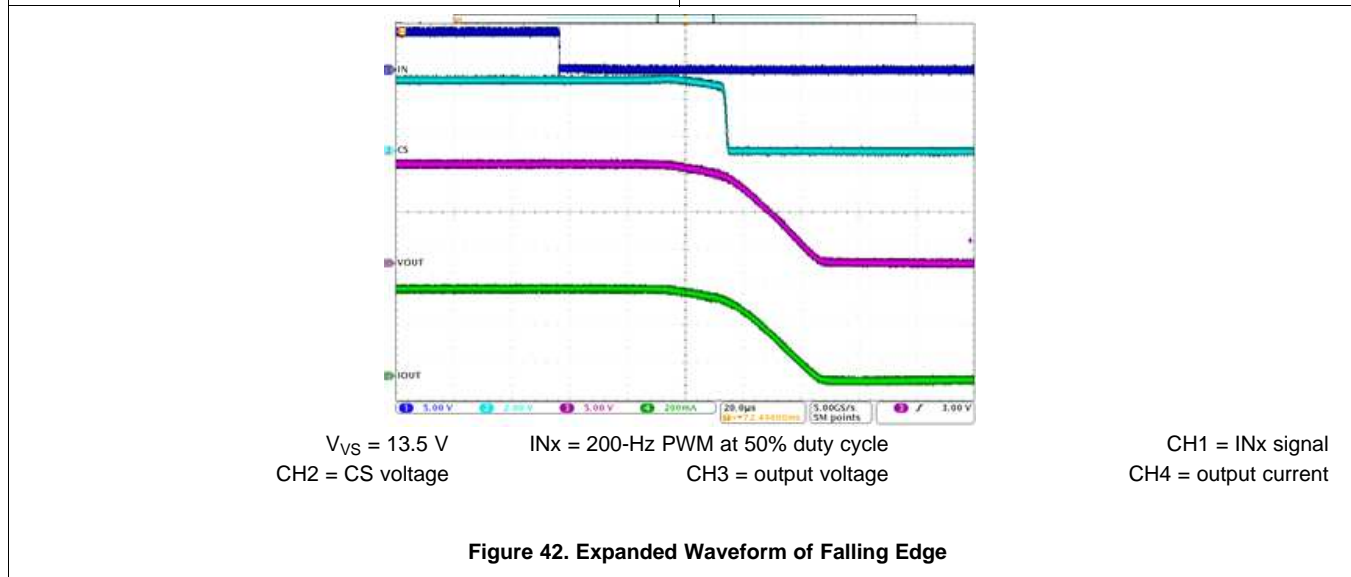
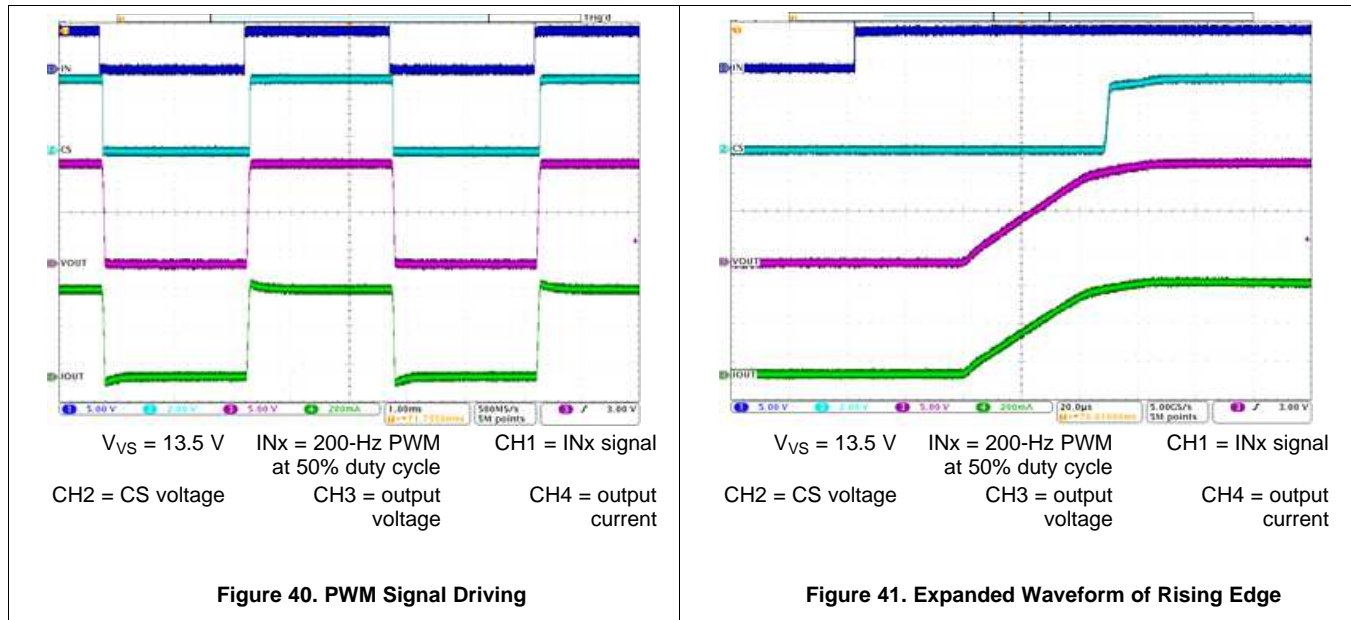

10 Power Supply Recommendations

The device is qualified for both automotive and industrial applications. The normal power supply connection is a 12-V automotive system or 24-V industrial system. Detailed supply voltage should be within the range specified in the *Recommended Operating Conditions*.

## 11 Layout

### 11.1 Layout Guidelines

To prevent thermal shutdown,  $T_J$  must be less than  $150^{\circ}\text{C}$ . The HTSSOP package has good thermal impedance. However, the PCB layout is very important. Good PCB design can optimize heat transfer, which is absolutely essential for the long-term reliability of the device.

- Maximize the copper coverage on the PCB to increase the thermal conductivity of the board. The major heat flow path from the package to the ambient is through the copper on the PCB. Maximum copper is extremely important when there are not any heat sinks attached to the PCB on the other side of the package.
- Add as many thermal vias as possible directly under the package ground pad to optimize the thermal conductivity of the board.
- All thermal vias should either be plated shut or plugged and capped on both sides of the board to prevent solder voids. To ensure reliability and performance, the solder coverage should be at least 85%.

### 11.2 Layout Examples

#### 11.2.1 Without a GND Network

Without a GND network, tie the thermal pad directly to the board GND copper for better thermal performance.

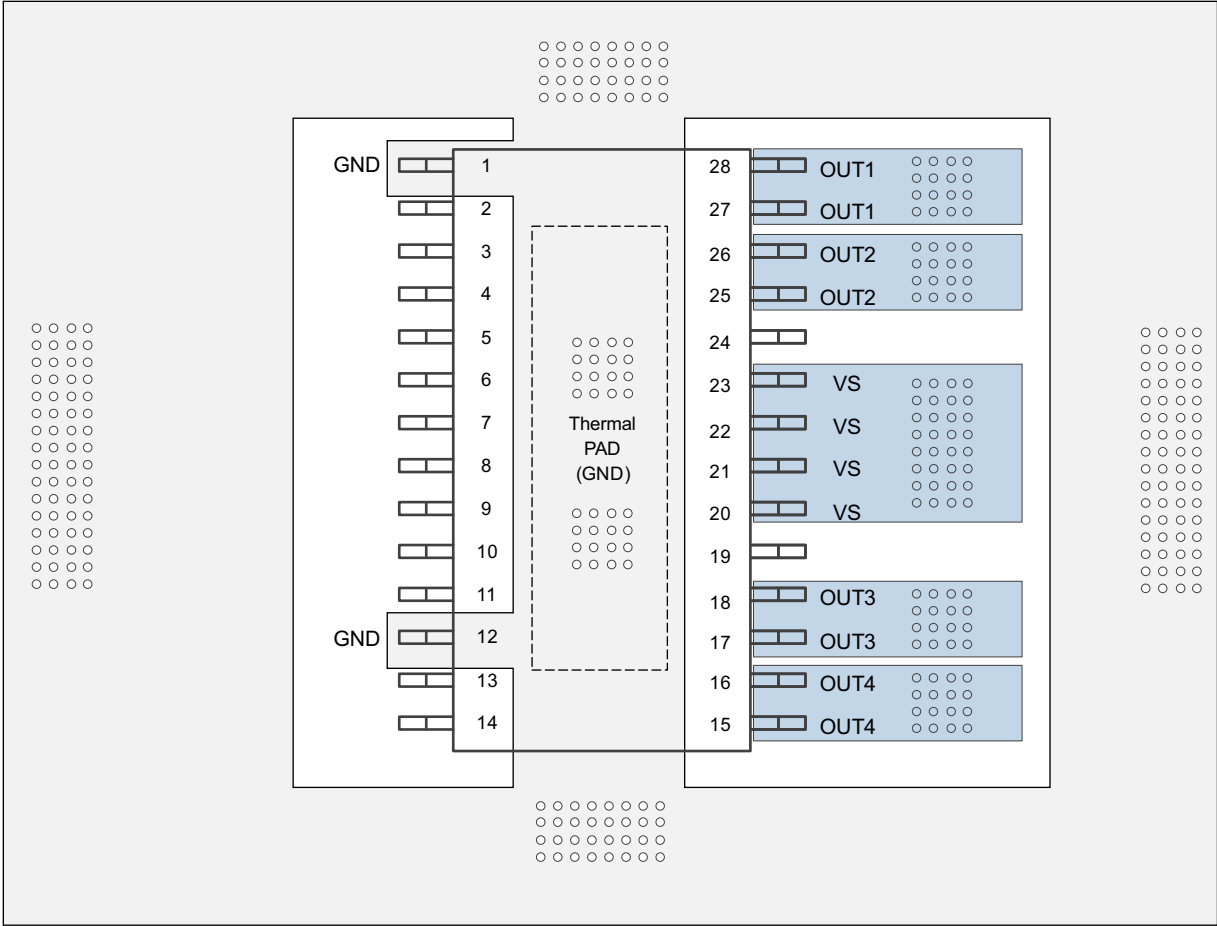

Figure 43. Layout Example Without a GND Network

## Layout Examples (continued)

### 11.2.2 With a GND Network

With a GND network, tie the thermal pad as one trace to the board GND copper.

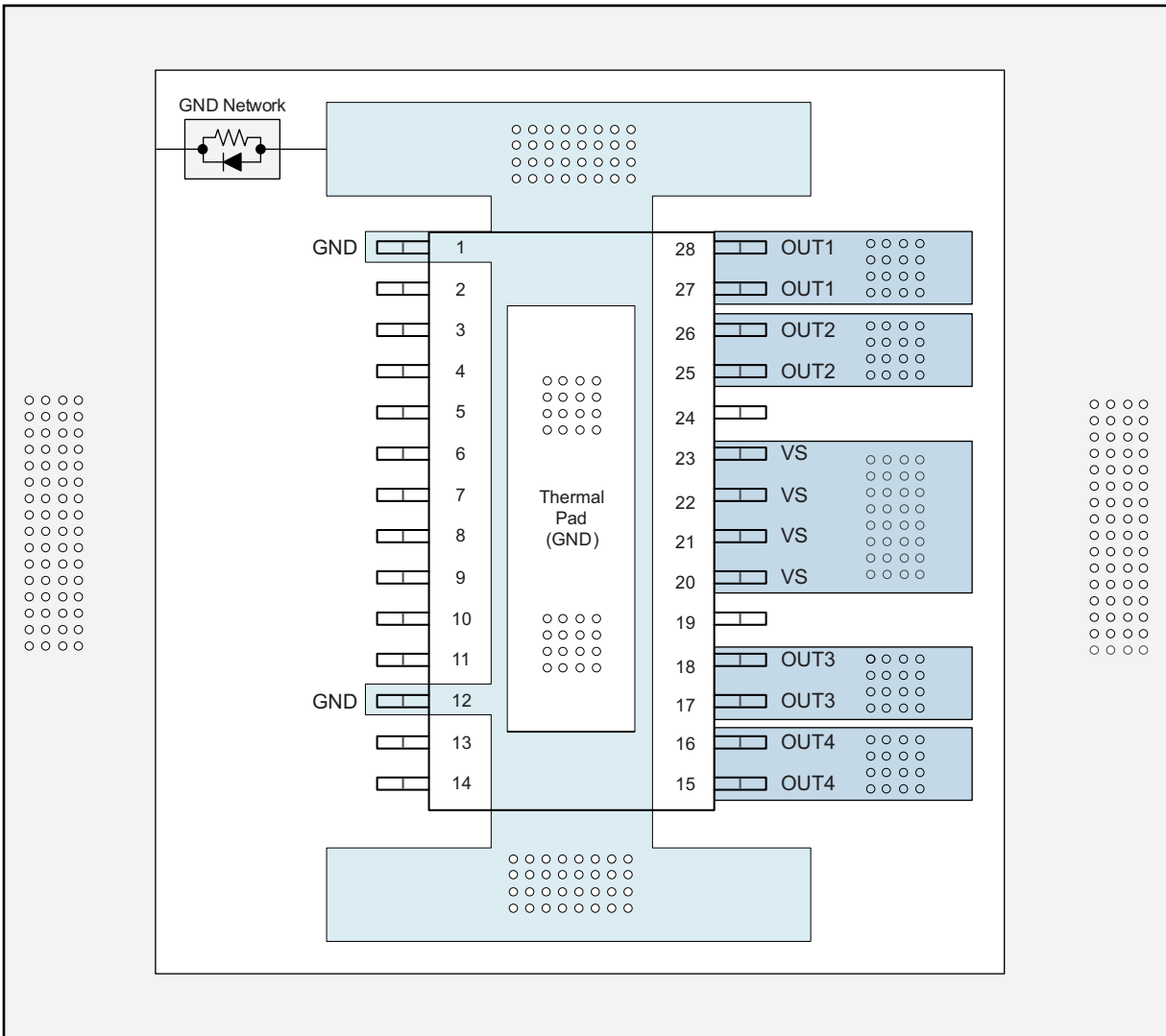

Figure 44. Layout Example With a GND Network



## 12 器件和文档支持

### 12.1 接收文档更新通知

要接收文档更新通知，请导航至 [ti.com](http://ti.com) 上的器件产品文件夹。请单击右上角的 [通知我](#) 进行注册，即可收到任意产品信息更改每周摘要。有关更改的详细信息，请查看任意已修订文档中包含的修订历史记录。

### 12.2 社区资源

The following links connect to TI community resources. Linked contents are provided "AS IS" by the respective contributors. They do not constitute TI specifications and do not necessarily reflect TI's views; see TI's [Terms of Use](#).

**TI E2E™ Online Community** *TI's Engineer-to-Engineer (E2E) Community*. Created to foster collaboration among engineers. At [e2e.ti.com](http://e2e.ti.com), you can ask questions, share knowledge, explore ideas and help solve problems with fellow engineers.

**Design Support** *TI's Design Support* Quickly find helpful E2E forums along with design support tools and contact information for technical support.

### 12.3 商标

E2E is a trademark of Texas Instruments.  
All other trademarks are the property of their respective owners.

### 12.4 静电放电警告



这些装置包含有限的内置 ESD 保护。存储或装卸时，应将导线一起截短或将装置放置于导电泡棉中，以防止 MOS 门极遭受静电损伤。

### 12.5 Glossary

[SLYZ022](#) — *TI Glossary*.

This glossary lists and explains terms, acronyms, and definitions.

## 13 机械、封装和可订购信息

以下页面包括机械、封装和可订购信息。这些信息是针对指定器件提供的最新数据。本数据随时可能发生变更并且不对本文档进行修订，恕不另行通知。要获得这份数据表的浏览器版本，请查阅左侧的导航窗格。

**PACKAGING INFORMATION**

| Orderable Device | Status<br>(1) | Package Type | Package Drawing | Pins | Package Qty | Eco Plan<br>(2)         | Lead/Ball Finish<br>(6) | MSL Peak Temp<br>(3) | Op Temp (°C) | Device Marking<br>(4/5) | Samples                 |
|------------------|---------------|--------------|-----------------|------|-------------|-------------------------|-------------------------|----------------------|--------------|-------------------------|-------------------------|
| TPS4H160AQPWPRQ1 | ACTIVE        | HTSSOP       | PWP             | 28   | 2000        | Green (RoHS & no Sb/Br) | CU NIPDAU               | Level-3-260C-168 HR  | -40 to 125   | 4H160AQ                 | <a href="#">Samples</a> |
| TPS4H160BQPWPRQ1 | ACTIVE        | HTSSOP       | PWP             | 28   | 2000        | Green (RoHS & no Sb/Br) | CU NIPDAU               | Level-3-260C-168 HR  | -40 to 125   | 4H160BQ                 | <a href="#">Samples</a> |

(1) The marketing status values are defined as follows:

**ACTIVE:** Product device recommended for new designs.

**LIFEBUY:** TI has announced that the device will be discontinued, and a lifetime-buy period is in effect.

**NRND:** Not recommended for new designs. Device is in production to support existing customers, but TI does not recommend using this part in a new design.

**PREVIEW:** Device has been announced but is not in production. Samples may or may not be available.

**OBSOLETE:** TI has discontinued the production of the device.

(2) Eco Plan - The planned eco-friendly classification: Pb-Free (RoHS), Pb-Free (RoHS Exempt), or Green (RoHS & no Sb/Br) - please check <http://www.ti.com/productcontent> for the latest availability information and additional product content details.

**TBD:** The Pb-Free/Green conversion plan has not been defined.

**Pb-Free (RoHS):** TI's terms "Lead-Free" or "Pb-Free" mean semiconductor products that are compatible with the current RoHS requirements for all 6 substances, including the requirement that lead not exceed 0.1% by weight in homogeneous materials. Where designed to be soldered at high temperatures, TI Pb-Free products are suitable for use in specified lead-free processes.

**Pb-Free (RoHS Exempt):** This component has a RoHS exemption for either 1) lead-based flip-chip solder bumps used between the die and package, or 2) lead-based die adhesive used between the die and leadframe. The component is otherwise considered Pb-Free (RoHS compatible) as defined above.

**Green (RoHS & no Sb/Br):** TI defines "Green" to mean Pb-Free (RoHS compatible), and free of Bromine (Br) and Antimony (Sb) based flame retardants (Br or Sb do not exceed 0.1% by weight in homogeneous material)

(3) MSL, Peak Temp. - The Moisture Sensitivity Level rating according to the JEDEC industry standard classifications, and peak solder temperature.

(4) There may be additional marking, which relates to the logo, the lot trace code information, or the environmental category on the device.

(5) Multiple Device Markings will be inside parentheses. Only one Device Marking contained in parentheses and separated by a "~" will appear on a device. If a line is indented then it is a continuation of the previous line and the two combined represent the entire Device Marking for that device.

(6) Lead/Ball Finish - Orderable Devices may have multiple material finish options. Finish options are separated by a vertical ruled line. Lead/Ball Finish values may wrap to two lines if the finish value exceeds the maximum column width.

**Important Information and Disclaimer:** The information provided on this page represents TI's knowledge and belief as of the date that it is provided. TI bases its knowledge and belief on information provided by third parties, and makes no representation or warranty as to the accuracy of such information. Efforts are underway to better integrate information from third parties. TI has taken and continues to take reasonable steps to provide representative and accurate information but may not have conducted destructive testing or chemical analysis on incoming materials and chemicals. TI and TI suppliers consider certain information to be proprietary, and thus CAS numbers and other limited information may not be available for release.

In no event shall TI's liability arising out of such information exceed the total purchase price of the TI part(s) at issue in this document sold by TI to Customer on an annual basis.

**TAPE AND REEL INFORMATION**

**QUADRANT ASSIGNMENTS FOR PIN 1 ORIENTATION IN TAPE**

\*All dimensions are nominal

| Device           | Package Type | Package Drawing | Pins | SPQ  | Reel Diameter (mm) | Reel Width W1 (mm) | A0 (mm) | B0 (mm) | K0 (mm) | P1 (mm) | W (mm) | Pin1 Quadrant |
|------------------|--------------|-----------------|------|------|--------------------|--------------------|---------|---------|---------|---------|--------|---------------|
| TPS4H160AQPWPRQ1 | HTSSOP       | PWP             | 28   | 2000 | 330.0              | 16.4               | 6.9     | 10.2    | 1.8     | 12.0    | 16.0   | Q1            |
| TPS4H160BQPWPRQ1 | HTSSOP       | PWP             | 28   | 2000 | 330.0              | 16.4               | 6.9     | 10.2    | 1.8     | 12.0    | 16.0   | Q1            |

**TAPE AND REEL BOX DIMENSIONS**



\*All dimensions are nominal

| Device          | Package Type | Package Drawing | Pins | SPQ  | Length (mm) | Width (mm) | Height (mm) |
|-----------------|--------------|-----------------|------|------|-------------|------------|-------------|
| TPS4H160AQPWRQ1 | HTSSOP       | PWP             | 28   | 2000 | 367.0       | 367.0      | 38.0        |
| TPS4H160BQPWRQ1 | HTSSOP       | PWP             | 28   | 2000 | 367.0       | 367.0      | 38.0        |

# MECHANICAL DATA

PWP (R-PDSO-G28)

PowerPAD™ PLASTIC SMALL OUTLINE



- NOTES:
- All linear dimensions are in millimeters.
  - This drawing is subject to change without notice.
  - Body dimensions do not include mold flash or protrusions. Mold flash and protrusion shall not exceed 0.15 per side.
  - This package is designed to be soldered to a thermal pad on the board. Refer to Technical Brief, PowerPad Thermally Enhanced Package, Texas Instruments Literature No. SLMA002 for information regarding recommended board layout. This document is available at [www.ti.com](http://www.ti.com) <<http://www.ti.com>>.
  - See the additional figure in the Product Data Sheet for details regarding the exposed thermal pad features and dimensions.
  - Falls within JEDEC MO-153

PowerPAD is a trademark of Texas Instruments.

# THERMAL PAD MECHANICAL DATA

## PWP (R-PDSO-G28) PowerPAD™ SMALL PLASTIC OUTLINE

### THERMAL INFORMATION

This PowerPAD™ package incorporates an exposed thermal pad that is designed to be attached to a printed circuit board (PCB). The thermal pad must be soldered directly to the PCB. After soldering, the PCB can be used as a heatsink. In addition, through the use of thermal vias, the thermal pad can be attached directly to the appropriate copper plane shown in the electrical schematic for the device, or alternatively, can be attached to a special heatsink structure designed into the PCB. This design optimizes the heat transfer from the integrated circuit (IC).

For additional information on the PowerPAD package and how to take advantage of its heat dissipating abilities, refer to Technical Brief, PowerPAD Thermally Enhanced Package, Texas Instruments Literature No. SLMA002 and Application Brief, PowerPAD Made Easy, Texas Instruments Literature No. SLMA004. Both documents are available at [www.ti.com](http://www.ti.com).

The exposed thermal pad dimensions for this package are shown in the following illustration.

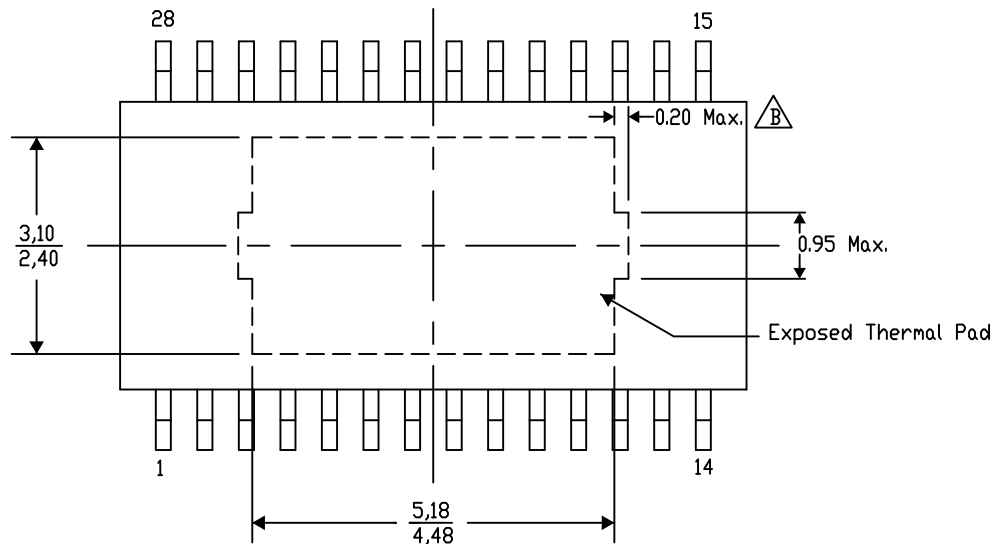

4206332-38/AO 01/16

NOTE: A. All linear dimensions are in millimeters  
B. Exposed tie strap features may not be present.

PowerPAD is a trademark of Texas Instruments

PWP (R-PDSO-G28)

PowerPAD™ PLASTIC SMALL OUTLINE

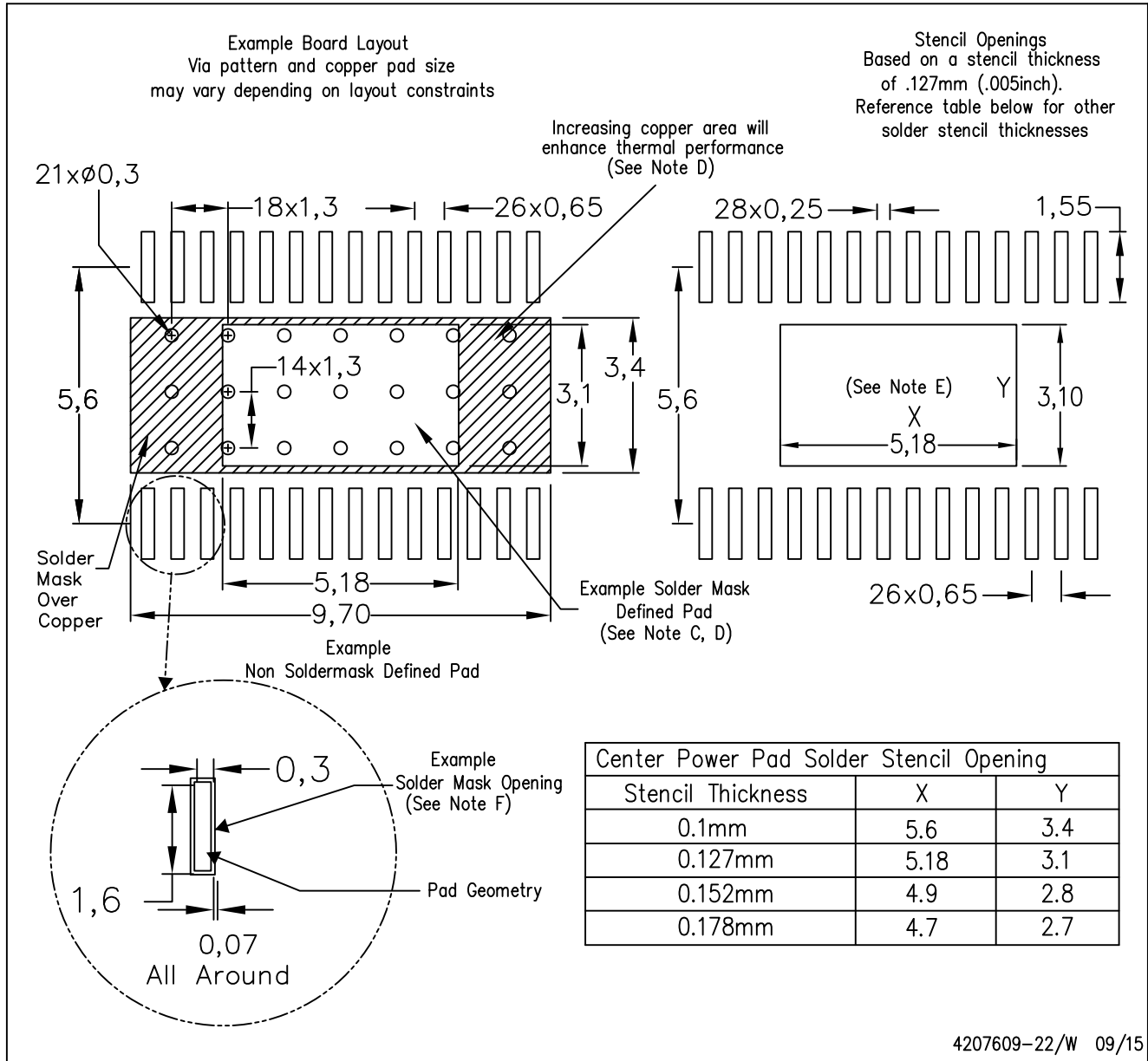

- NOTES:
- All linear dimensions are in millimeters.
  - This drawing is subject to change without notice.
  - Customers should place a note on the circuit board fabrication drawing not to alter the center solder mask defined pad.
  - This package is designed to be soldered to a thermal pad on the board. Refer to Technical Brief, PowerPad Thermally Enhanced Package, Texas Instruments Literature No. SLMA002, SLMA004, and also the Product Data Sheets.
  - For specific thermal information, via requirements, and recommended board layout. These documents are available at [www.ti.com](http://www.ti.com) <<http://www.ti.com>>. Publication IPC-7351 is recommended for alternate designs. Laser cutting apertures with trapezoidal walls and also rounding corners will offer better paste release. Customers should contact their board assembly site for stencil design recommendations. Example stencil design based on a 50% volumetric metal load solder paste. Refer to IPC-7525 for other stencil
  - Customers should contact their board fabrication site for solder mask tolerances between and around signal pads.



## 重要声明

德州仪器 (TI) 公司有权按照最新发布的 JESD46 对其半导体产品和服务进行纠正、增强、改进和其他修改，并不再按最新发布的 JESD48 提供任何产品和服务。买方在下订单前应获取最新的相关信息，并验证这些信息是否完整且是最新的。

TI 公布的半导体产品销售条款 (<http://www.ti.com/sc/docs/stdterms.htm>) 适用于 TI 已认证和批准上市的已封装集成电路产品的销售。另有其他条款可能适用于其他类型 TI 产品及服务的使用或销售。

复制 TI 数据表上 TI 信息的重要部分时，不得变更该等信息，且必须随附所有相关保证、条件、限制和通知，否则不得复制。TI 对该等复制文件不承担任何责任。第三方信息可能受到其它限制条件的制约。在转售 TI 产品或服务时，如果存在对产品或服务参数的虚假陈述，则会失去相关 TI 产品或服务的明示或暗示保证，且构成不公平的、欺诈性商业行为。TI 对此类虚假陈述不承担任何责任。

买方和在系统中整合 TI 产品的其他开发人员（总称“设计人员”）理解并同意，设计人员在设计应用时应自行实施独立的分析、评价和判断，且应全权负责并确保应用的安全性，及设计人员的应用（包括应用中使用的 TI 产品）应符合所有适用的法律法规及其他相关要求。设计人员就自己设计的应用声明，其具备制订和实施下列保障措施所需的一切必要专业知识，能够 (1) 预见故障的危险后果，(2) 监视故障及其后果，以及 (3) 降低可能导致危险的故障几率并采取适当措施。设计人员同意，在使用或分发包含 TI 产品的任何应用前，将彻底测试该等应用和该等应用中所用 TI 产品的功能。

TI 提供技术、应用或其他设计建议、质量特点、可靠性数据或其他服务或信息，包括但不限于与评估模块有关的参考设计和材料（总称“TI 资源”），旨在帮助设计人员开发整合了 TI 产品的应用，如果设计人员（个人，或如果是代表公司，则为设计人员的公司）以任何方式下载、访问或使用任何特定的 TI 资源，即表示其同意仅为该等目标，按照本通知的条款使用任何特定 TI 资源。

TI 所提供的 TI 资源，并未扩大或以其他方式修改 TI 对 TI 产品的公开适用的质保及质保免责声明；也未导致 TI 承担任何额外的义务或责任。TI 有权对其 TI 资源进行纠正、增强、改进和其他修改。除特定 TI 资源的公开文档中明确列出的测试外，TI 未进行任何其他测试。

设计人员只有在开发包含该等 TI 资源所列 TI 产品的应用时，才被授权使用、复制和修改任何相关 TI 资源。但并未依据禁止反言原则或其他法律授予您任何 TI 知识产权的任何其他明示或默示的许可，也未授予您 TI 或第三方的任何技术或知识产权的许可，该等许可包括但不限于任何专利权、版权、屏蔽作品权或与美国 TI 产品或服务的任何整合、机器制作、流程相关的其他知识产权。涉及或参考了第三方产品或服务的信息不构成使用此类产品或服务的许可或与其相关的保证或认可。使用 TI 资源可能需要您向第三方获得对该等第三方专利或其他知识产权的许可。

TI 资源系“按原样”提供。TI 兹免除对资源及其使用作出所有其他明确或默示的保证或陈述，包括但不限于对准确性或完整性、产权保证、无屡发故障保证，以及适销性、适合特定用途和不侵犯任何第三方知识产权的任何默认保证。TI 不负责任何申索，包括但不限于因组合产品所致或与之有关的申索，也不为或对设计人员进行辩护或赔偿，即使该等产品组合已列于 TI 资源或其他地方。对因 TI 资源或其使用引起或与之有关的任何实际的、直接的、特殊的、附带的、间接的、惩罚性的、偶发的、从属或惩戒性损害赔偿，不管 TI 是否获悉可能会产生上述损害赔偿，TI 概不负责。

除 TI 已明确指出特定产品已达到特定行业标准（例如 ISO/TS 16949 和 ISO 26262）的要求外，TI 不对未达到任何该等行业标准要求而承担任何责任。

如果 TI 明确宣称产品有助于功能安全或符合行业功能安全标准，则该等产品旨在帮助客户设计和创作自己的符合相关功能安全标准和要求的的应用。在应用内使用产品的行为本身不会配有安全特性。设计人员必须确保遵守适用于其应用的相关安全要求和标准。设计人员不可将任何 TI 产品用于关乎性命的医疗设备，除非已由各方获得授权的管理人员签署专门的合同对此类应用专门作出规定。关乎性命的医疗设备是指出现故障会导致严重身体伤害或死亡的医疗设备（例如生命保障设备、心脏起搏器、心脏除颤器、人工心脏泵、神经刺激器以及植入设备）。此类设备包括但不限于，美国食品药品监督管理局认定为 III 类设备的设备，以及在美国以外的其他国家或地区认定为同等类别设备的所有医疗设备。

TI 可能明确指定某些产品具备某些特定资格（例如 Q100、军用级或增强型产品）。设计人员同意，其具备一切必要专业知识，可以为自己的应用选择适合的产品，并且正确选择产品的风险由设计人员承担。设计人员单方面负责遵守与该等选择有关的所有法律或监管要求。

设计人员同意向 TI 及其代表全额赔偿因其不遵守本通知条款和条件而引起的任何损害、费用、损失和/或责任。

邮寄地址：上海市浦东新区世纪大道 1568 号中建大厦 32 楼，邮政编码：200122  
Copyright © 2017 德州仪器半导体技术（上海）有限公司