TRF4140-Q1 Abstract

Low-Frequency Transceiver for Immobilizer, Passive Start, Passive Entry, and Wireless Charging Systems

1 Device Overview

1.1 Features

- Benefits
 - Full Embedded Sequence Timing Controller Removes All Timing Constraints From the Host Controller
 - Automatic Sequence Repetition for Easy Implementation of Energy-Efficient Polling Systems
 - Separate Transmit and Receive Buffers Reduce Host Controller Performance Requirements
 - Embedded Sequence-Auto-Repeat Enables Low-Power Polling System Without Host Controller Interaction
 - Embedded Half-Duplex (HDX) and Full-Duplex (FDX) Protocol Support Enables Flexible and Scalable System Implementation
 - Sine-Wave Controlled Transmitter Stages Enable High-Power Remote Antenna Systems With Cable Lengths of Several Meters and Superior EMC Performance
 - Sequence Preloading With Event-Triggered Execution for Fastest System Reaction Time
 - Supports Wireless Charging Systems for Mobile Devices
- Features
 - Integrated Boost Controller for Wide Supply Voltage Range With Jump Start and Load Dump Protection
 - Antenna Driver With up to 20-V Peak-to-Peak Output Voltage Amplitude and up to 1-A Peak Antenna Current With Sine-Wave or Square-Wave Output
 - Flexible Host Control Interface
 - 3-Wire SPI
 - 4-Wire SPI
 - Configurable I/O Functions to Extend Controller Interface Such as an Interrupt Request Signal
 - Interface Voltage Supply Range From 2.5 V to 5.5 V
 - Ultra-Low Current Consumption in Sleep State
 - Fractional Synthesizer With 10-kHz to 500-kHz Frequency Range With 60-Hz Step Size
 - PSK and ASK Transmitter Stage
 - FSK and ASK Receiver and Demodulator
 - Four Programmable Half-Bridge MOSFET Antenna Drivers
 - Pairs of Half-Bridge Antenna Drivers can be Used Together as a Full-Bridge Driver to Double the Possible Output Voltage Amplitude
 - Antenna Current Measurement With 5-Bit Resolution for High Side and Low Side of Antenna Driver Stages
 - Programmable Antenna Driver Output Voltage in Sine-Wave Mode
 - Supply-Controlled Antenna Driver Voltage in Square-Wave Mode
 - Output Stage is Overload Protected for Overcurrent and Overtemperature Conditions
 - Antenna Driver Diagnostics: Short to Ground, Short to Antenna Driver Supply Voltage, and Open Load Detection
 - Supports On-Off Keying With Data Rates up to 70 kbps for Downlink and Uplink

1.2 Applications

- Car Access
- Immobilizers
- Passive Entry, Passive Start (PEPS)
- Wireless Power Charging (Qi, WPC, PMA)
- RFID Tag Readers (Full Duplex and Half Duplex)
- Other Applications Where the Physical Characteristics of Low-Frequency Radio are Beneficial



1.3 Description

NOTE

This document is an abbreviated version of the full TRF4140 data sheet. For access to the full data sheet, silicon errata, application report, and other support collateral, [complete the request form](#).

The TRF4140 low-frequency (LF) transceiver base station device is intended for immobilizer and PEPS systems to communicate with LF transponders, remote keyless entry, and passive entry devices and also to support wireless charging. The antenna driver stage consists of several MOSFET antenna drivers to send modulated LF transmissions and a receiver for detection and demodulation of LF transponder responses. The responses can be from either a half-duplex (HDX) transponder or a full-duplex (FDX) transponder. The HDX communication scheme uses frequency shift keying (FSK) as the uplink modulation. The FDX communication scheme uses amplitude shift keying (ASK) as the uplink modulation, also known as load modulation or backscatter modulation. The device can drive LF antennas to provide a wake-up and data sequence (PEPS), and it can also receive transponder responses on any or all channels (immobilizer).

The TRF4140 device lets the user implement an intelligent system, suitable for wireless power charging (WPC). The WPC system can periodically check the surrounding environment for available devices to be powered while minimizing idle power, monitor all communications from the mobile device being wirelessly powered, and control the output power that is applied to the transmitter coil according to information received from the powered device. The system can manage fault conditions associated with power transfer and can control status signals by using current measurement and LED-capable I/Os to indicate operating modes.

The TRF4140 device needs VDD supply (5 V) for its control blocks and to feed the integrated logic voltage regulator. The antenna driver is supplied separately by VDDH (4 V to 20 V). This voltage can be used to generate a sine-wave output signal for superior EMC performance, which is important for remote antenna applications with several meters of antenna cable.

The TRF4140 device manages all timings required for a communication sequence without the need for an accurate host controller interaction. In conjunction with transmit and receive FIFOs, the host controller is off-loaded from all timing-critical events, which enables easy host controller process scheduling. In particular, the host controller start-up process for an automotive body control module is tremendously relaxed by this base station device.

The TRF4140 device supports sequence preloading and sequence execution on external events to start the immobilization process exactly when the key fob is detected. So, delays due to configuration can be avoided in inconvenient time frames.

Device Information⁽¹⁾

| PART NUMBER | PACKAGE | BODY SIZE |
|-------------|------------|-------------|
| TRF4140QPHN | HTQFP (48) | 7 mm x 7 mm |

(1) For more information, see [Section 4, Mechanical Packaging and Orderable Information](#).

1.4 Functional Block Diagram

Figure 1-1 shows the functional block diagram and a typical application of TRF4140 and its function blocks.

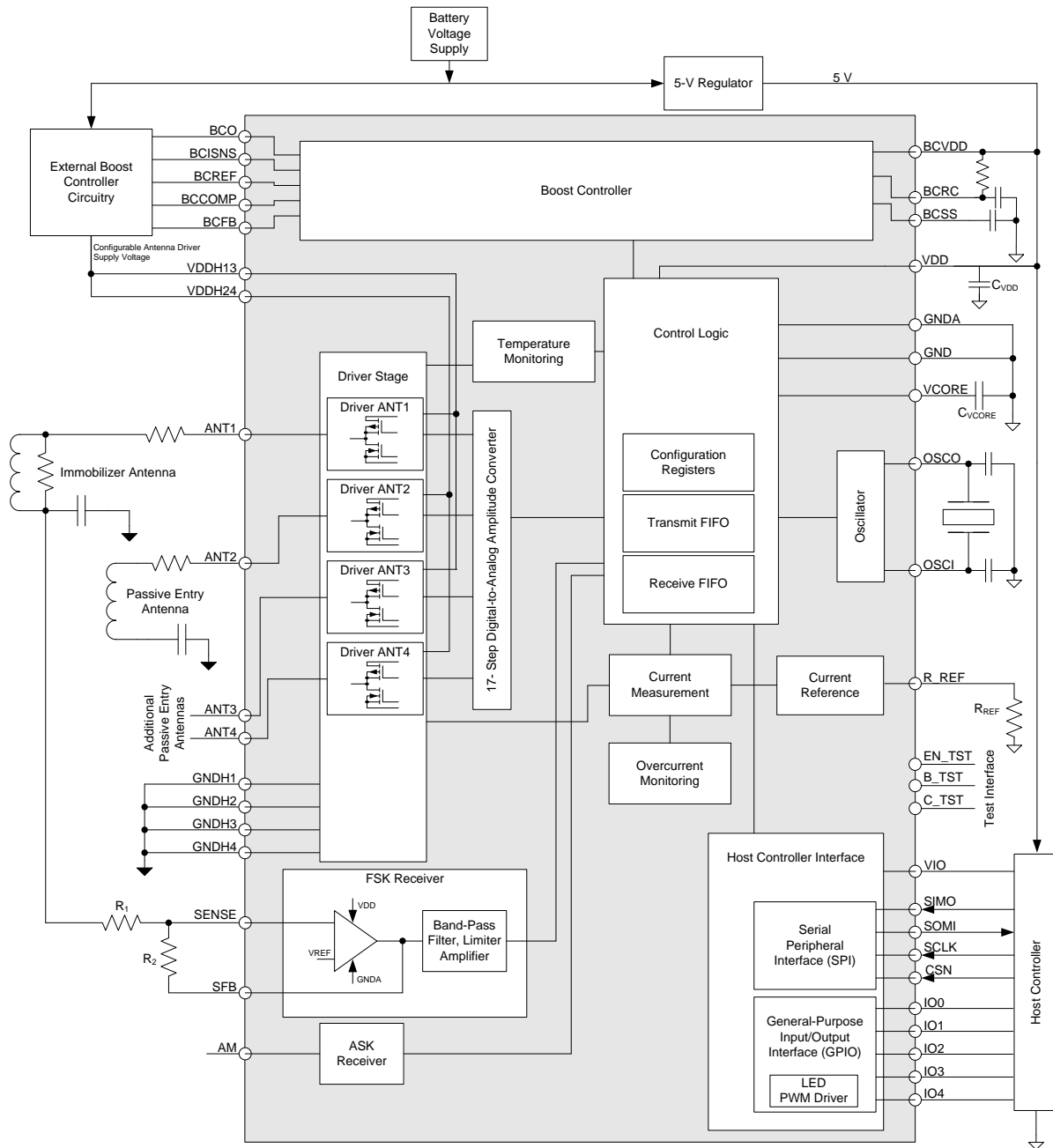

BAST_FBD_4ANT

Copyright © 2016, Texas Instruments Incorporated

Figure 1-1. TRF4140-Q1 Block Diagram and Application Example

Table of Contents

| | | | |
|---|--------------------------|---|--------------------------|
| 1 Device Overview | 1 | 3.2 Device Nomenclature..... | 5 |
| 1.1 Features | 1 | 3.3 Documentation Support | 5 |
| 1.2 Applications..... | 1 | 3.4 Community Resources | 6 |
| 1.3 Description | 2 | 3.5 Trademarks | 6 |
| 1.4 Functional Block Diagram | 3 | 3.6 Electrostatic Discharge Caution | 6 |
| 2 Revision History | 4 | 3.7 Export Control Notice..... | 6 |
| 3 Device and Documentation Support | 5 | 3.8 Glossary | 6 |
| 3.1 Getting Started and Next Steps | 5 | 4 Mechanical, Packaging, and Orderable Information | 7 |

2 Revision History

Changes from June 1, 2016 to June 27, 2016

Page

- Changed package designator to PHN in *Device Information* table **[2](#)**

3 Device and Documentation Support

3.1 Getting Started and Next Steps

For more information on the TI NFC/RFID devices and the tools and software that are available to help with your development, visit [Overview for NFC / RFID](#).

3.2 Device Nomenclature

Figure 3-1 provides a legend for reading the complete device name for any family member.

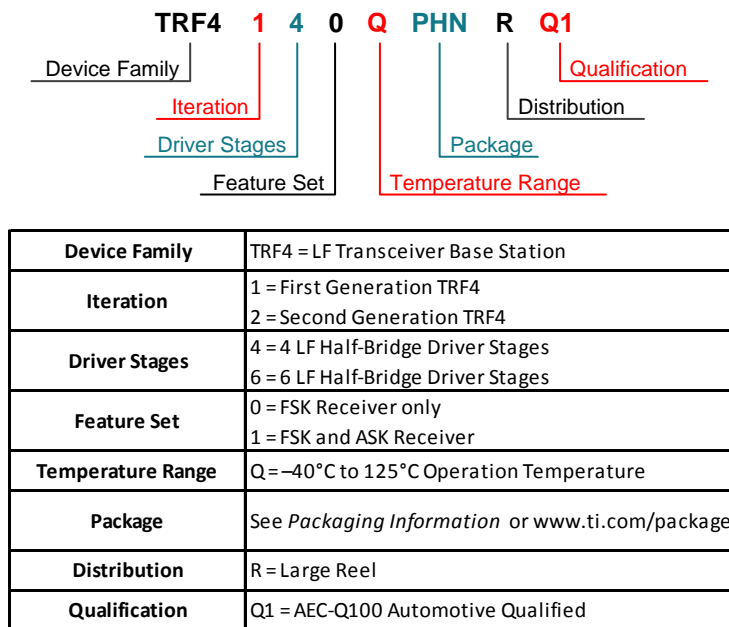

Figure 3-1. Device Nomenclature

3.3 Documentation Support

The following documents describe the TRF4140 device. Copies of these documents are available on the Internet at www.ti.com.

Receiving Notice of Document Updates

To receive notification of documentation updates—including silicon errata—go to the product folder for your device on ti.com (for example, [TRF4140-Q1](#)). In the upper right corner, click the "Alert me" button. This registers you to receive a weekly digest of product information that has changed (if any). For change details, check the revision history of any revised document.

Errata

[TRF4140 Errata Sheet](#) Describes known design exceptions and related workarounds of this device.

Application Reports

[Using a TRF4xxx Device as an LF Transceiver Base Station](#) Provides a variety of application advice for designing an LF base station with TRF4140 or TRF4260 devices.

3.4 Community Resources

The following link connects to TI community resources. Linked contents are provided "AS IS" by the respective contributors. They do not constitute TI specifications and do not necessarily reflect TI's views; see TI's [Terms of Use](#).

TI E2E™ Community

TI's Engineer-to-Engineer (E2E) Community. Created to foster collaboration among engineers. At e2e.ti.com, you can ask questions, share knowledge, explore ideas and help solve problems with fellow engineers.

3.5 Trademarks

E2E is a trademark of Texas Instruments.

3.6 Electrostatic Discharge Caution



This integrated circuit can be damaged by ESD. Texas Instruments recommends that all integrated circuits be handled with appropriate precautions. Failure to observe proper handling and installation procedures can cause damage.

ESD damage can range from subtle performance degradation to complete device failure. Precision integrated circuits may be more susceptible to damage because very small parametric changes could cause the device not to meet its published specifications.

3.7 Export Control Notice

Recipient agrees to not knowingly export or re-export, directly or indirectly, any product or technical data (as defined by the U.S., EU, and other Export Administration Regulations) including software, or any controlled product restricted by other applicable national regulations, received from disclosing party under nondisclosure obligations (if any), or any direct product of such technology, to any destination to which such export or re-export is restricted or prohibited by U.S. or other applicable laws, without obtaining prior authorization from U.S. Department of Commerce and other competent Government authorities to the extent required by those laws.

3.8 Glossary

[TI Glossary](#) This glossary lists and explains terms, acronyms, and definitions.

4 Mechanical, Packaging, and Orderable Information

The following pages include mechanical, packaging, and orderable information. This information is the most current data available for the designated devices. This data is subject to change without notice and revision of this document. For browser-based versions of this data sheet, refer to the left-hand navigation.

Mechanical Data

PHN (S-PQFP-G48)

PowerPAD™ PLASTIC QUAD FLATPACK

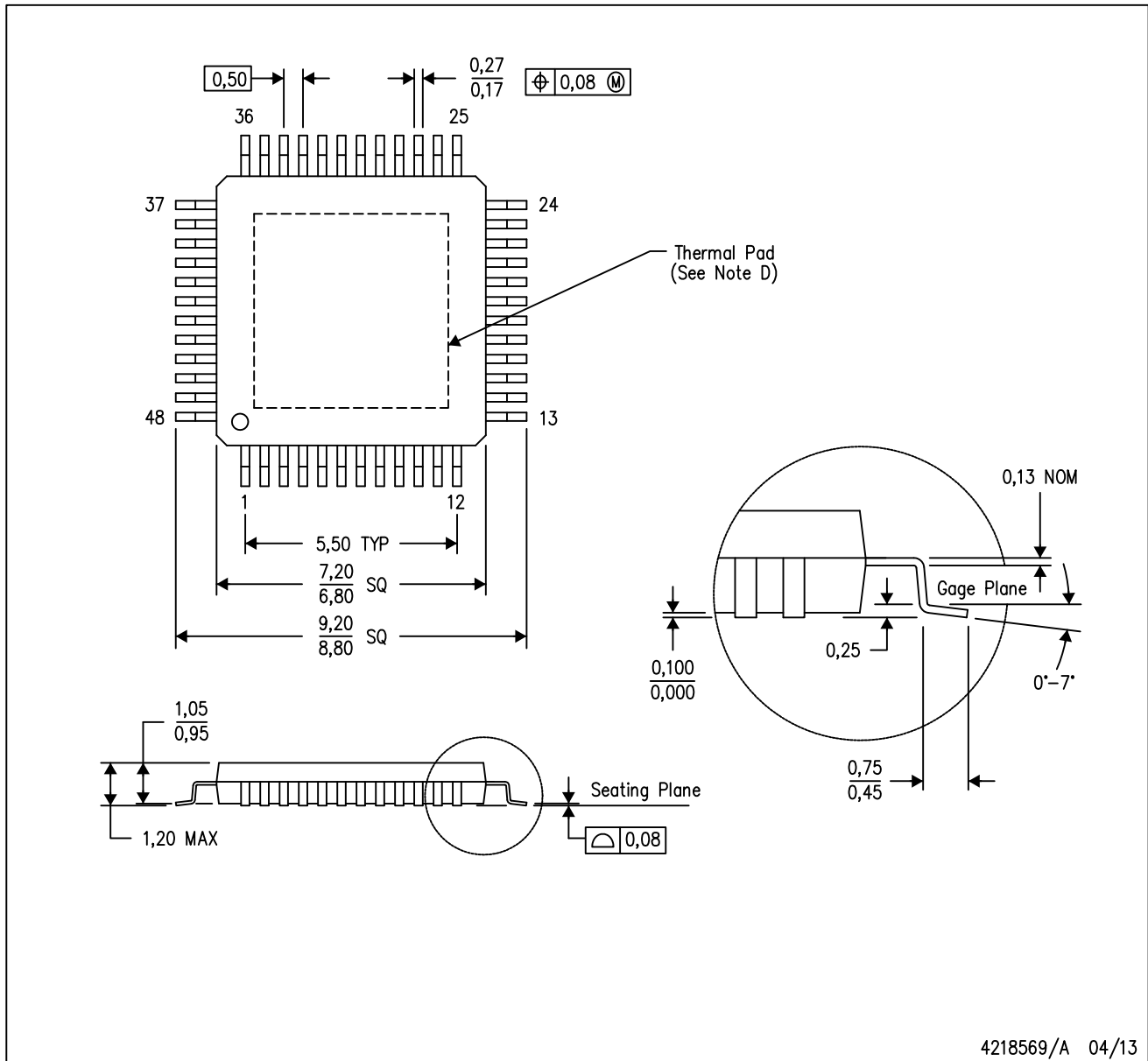

4218569/A 04/13

- NOTES:
- A. All linear dimensions are in millimeters.
 - B. This drawing is subject to change without notice.
 - C. Body dimensions do not include mold flash or protrusion
 - D. This package is designed to be soldered to a thermal pad on the board. Refer to Technical Brief, PowerPad Thermally Enhanced Package, Texas Instruments Literature No. SLMA002 for information regarding recommended board layout. This document is available at www.ti.com <<http://www.ti.com>>.
 - E. Falls within JEDEC MS-026

PowerPAD is a trademark of Texas Instruments.

THERMAL INFORMATION

This PowerPAD™ package incorporates an exposed thermal pad that is designed to be attached to a printed circuit board (PCB). The thermal pad must be soldered directly to the PCB. After soldering, the PCB can be used as a heatsink. In addition, through the use of thermal vias, the thermal pad can be attached directly to the appropriate copper plane shown in the electrical schematic for the device, or alternatively, can be attached to a special heatsink structure designed into the PCB. This design optimizes the heat transfer from the integrated circuit (IC).

For additional information on the PowerPAD package and how to take advantage of its heat dissipating abilities, refer to Technical Brief, PowerPAD Thermally Enhanced Package, Texas Instruments Literature No. [SLMA002](#) and Application Brief, PowerPAD Made Easy, Texas Instruments Literature No. [SLMA004](#). Both documents are available at [www.ti.com](#).

The exposed thermal pad dimensions for this package are shown in the following illustration.

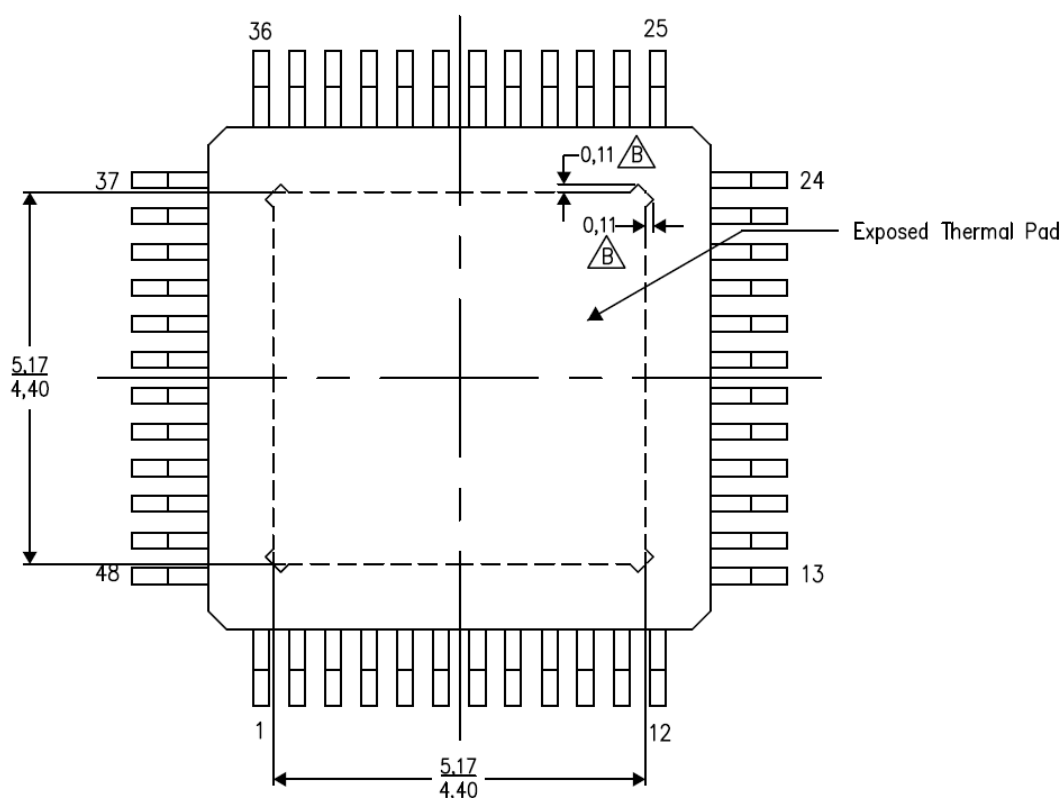

Top View
Exposed Thermal Pad Dimensions

4206329-7/N 04/12

NOTE: A. All linear dimensions are in millimeters

Tie strap features may not be present.

PowerPAD is a trademark of Texas Instruments

PACKAGING INFORMATION

| Orderable Device | Status (1) | Package Type | Package Drawing | Pins | Package Qty | Eco Plan (2) | Lead/Ball Finish (6) | MSL Peak Temp (3) | Op Temp (°C) | Device Marking (4/5) | Samples |
|------------------|---------------|--------------|--------------------|------|----------------|----------------------------|-------------------------|----------------------|--------------|-------------------------|---------|
| TRF4140QPHNRQ1 | ACTIVE | HTQFP | PHN | 48 | 2000 | Green (RoHS & no Sb/Br) | CU NIPDAU | Level-3-260C-168 HR | -40 to 125 | TRF4140C | Samples |

(1) The marketing status values are defined as follows:

ACTIVE: Product device recommended for new designs.

LIFEBUY: TI has announced that the device will be discontinued, and a lifetime-buy period is in effect.

NRND: Not recommended for new designs. Device is in production to support existing customers, but TI does not recommend using this part in a new design.

PREVIEW: Device has been announced but is not in production. Samples may or may not be available.

OBSELETE: TI has discontinued the production of the device.

(2) Eco Plan - The planned eco-friendly classification: Pb-Free (RoHS), Pb-Free (RoHS Exempt), or Green (RoHS & no Sb/Br) - please check <http://www.ti.com/productcontent> for the latest availability information and additional product content details.

TBD: The Pb-Free/Green conversion plan has not been defined.

Pb-Free (RoHS): TI's terms "Lead-Free" or "Pb-Free" mean semiconductor products that are compatible with the current RoHS requirements for all 6 substances, including the requirement that lead not exceed 0.1% by weight in homogeneous materials. Where designed to be soldered at high temperatures, TI Pb-Free products are suitable for use in specified lead-free processes.

Pb-Free (RoHS Exempt): This component has a RoHS exemption for either 1) lead-based flip-chip solder bumps used between the die and package, or 2) lead-based die adhesive used between the die and leadframe. The component is otherwise considered Pb-Free (RoHS compatible) as defined above.

Green (RoHS & no Sb/Br): TI defines "Green" to mean Pb-Free (RoHS compatible), and free of Bromine (Br) and Antimony (Sb) based flame retardants (Br or Sb do not exceed 0.1% by weight in homogeneous material)

(3) MSL, Peak Temp. - The Moisture Sensitivity Level rating according to the JEDEC industry standard classifications, and peak solder temperature.

(4) There may be additional marking, which relates to the logo, the lot trace code information, or the environmental category on the device.

(5) Multiple Device Markings will be inside parentheses. Only one Device Marking contained in parentheses and separated by a "~" will appear on a device. If a line is indented then it is a continuation of the previous line and the two combined represent the entire Device Marking for that device.

(6) Lead/Ball Finish - Orderable Devices may have multiple material finish options. Finish options are separated by a vertical ruled line. Lead/Ball Finish values may wrap to two lines if the finish value exceeds the maximum column width.

Important Information and Disclaimer:The information provided on this page represents TI's knowledge and belief as of the date that it is provided. TI bases its knowledge and belief on information provided by third parties, and makes no representation or warranty as to the accuracy of such information. Efforts are underway to better integrate information from third parties. TI has taken and continues to take reasonable steps to provide representative and accurate information but may not have conducted destructive testing or chemical analysis on incoming materials and chemicals. TI and TI suppliers consider certain information to be proprietary, and thus CAS numbers and other limited information may not be available for release.

In no event shall TI's liability arising out of such information exceed the total purchase price of the TI part(s) at issue in this document sold by TI to Customer on an annual basis.

IMPORTANT NOTICE

Texas Instruments Incorporated (TI) reserves the right to make corrections, enhancements, improvements and other changes to its semiconductor products and services per JESD46, latest issue, and to discontinue any product or service per JESD48, latest issue. Buyers should obtain the latest relevant information before placing orders and should verify that such information is current and complete.

TI's published terms of sale for semiconductor products (<http://www.ti.com/sc/docs/stdterms.htm>) apply to the sale of packaged integrated circuit products that TI has qualified and released to market. Additional terms may apply to the use or sale of other types of TI products and services.

Reproduction of significant portions of TI information in TI data sheets is permissible only if reproduction is without alteration and is accompanied by all associated warranties, conditions, limitations, and notices. TI is not responsible or liable for such reproduced documentation. Information of third parties may be subject to additional restrictions. Resale of TI products or services with statements different from or beyond the parameters stated by TI for that product or service voids all express and any implied warranties for the associated TI product or service and is an unfair and deceptive business practice. TI is not responsible or liable for any such statements.

Buyers and others who are developing systems that incorporate TI products (collectively, "Designers") understand and agree that Designers remain responsible for using their independent analysis, evaluation and judgment in designing their applications and that Designers have full and exclusive responsibility to assure the safety of Designers' applications and compliance of their applications (and of all TI products used in or for Designers' applications) with all applicable regulations, laws and other applicable requirements. Designer represents that, with respect to their applications, Designer has all the necessary expertise to create and implement safeguards that (1) anticipate dangerous consequences of failures, (2) monitor failures and their consequences, and (3) lessen the likelihood of failures that might cause harm and take appropriate actions. Designer agrees that prior to using or distributing any applications that include TI products, Designer will thoroughly test such applications and the functionality of such TI products as used in such applications.

TI's provision of technical, application or other design advice, quality characterization, reliability data or other services or information, including, but not limited to, reference designs and materials relating to evaluation modules, (collectively, "TI Resources") are intended to assist designers who are developing applications that incorporate TI products; by downloading, accessing or using TI Resources in any way, Designer (individually or, if Designer is acting on behalf of a company, Designer's company) agrees to use any particular TI Resource solely for this purpose and subject to the terms of this Notice.

TI's provision of TI Resources does not expand or otherwise alter TI's applicable published warranties or warranty disclaimers for TI products, and no additional obligations or liabilities arise from TI providing such TI Resources. TI reserves the right to make corrections, enhancements, improvements and other changes to its TI Resources. TI has not conducted any testing other than that specifically described in the published documentation for a particular TI Resource.

Designer is authorized to use, copy and modify any individual TI Resource only in connection with the development of applications that include the TI product(s) identified in such TI Resource. NO OTHER LICENSE, EXPRESS OR IMPLIED, BY ESTOPPEL OR OTHERWISE TO ANY OTHER TI INTELLECTUAL PROPERTY RIGHT, AND NO LICENSE TO ANY TECHNOLOGY OR INTELLECTUAL PROPERTY RIGHT OF TI OR ANY THIRD PARTY IS GRANTED HEREIN, including but not limited to any patent right, copyright, mask work right, or other intellectual property right relating to any combination, machine, or process in which TI products or services are used. Information regarding or referencing third-party products or services does not constitute a license to use such products or services, or a warranty or endorsement thereof. Use of TI Resources may require a license from a third party under the patents or other intellectual property of the third party, or a license from TI under the patents or other intellectual property of TI.

TI RESOURCES ARE PROVIDED "AS IS" AND WITH ALL FAULTS. TI DISCLAIMS ALL OTHER WARRANTIES OR REPRESENTATIONS, EXPRESS OR IMPLIED, REGARDING RESOURCES OR USE THEREOF, INCLUDING BUT NOT LIMITED TO ACCURACY OR COMPLETENESS, TITLE, ANY EPIDEMIC FAILURE WARRANTY AND ANY IMPLIED WARRANTIES OF MERCHANTABILITY, FITNESS FOR A PARTICULAR PURPOSE, AND NON-INFRINGEMENT OF ANY THIRD PARTY INTELLECTUAL PROPERTY RIGHTS. TI SHALL NOT BE LIABLE FOR AND SHALL NOT DEFEND OR INDEMNIFY DESIGNER AGAINST ANY CLAIM, INCLUDING BUT NOT LIMITED TO ANY INFRINGEMENT CLAIM THAT RELATES TO OR IS BASED ON ANY COMBINATION OF PRODUCTS EVEN IF DESCRIBED IN TI RESOURCES OR OTHERWISE. IN NO EVENT SHALL TI BE LIABLE FOR ANY ACTUAL, DIRECT, SPECIAL, COLLATERAL, INDIRECT, PUNITIVE, INCIDENTAL, CONSEQUENTIAL OR EXEMPLARY DAMAGES IN CONNECTION WITH OR ARISING OUT OF TI RESOURCES OR USE THEREOF, AND REGARDLESS OF WHETHER TI HAS BEEN ADVISED OF THE POSSIBILITY OF SUCH DAMAGES.

Unless TI has explicitly designated an individual product as meeting the requirements of a particular industry standard (e.g., ISO/TS 16949 and ISO 26262), TI is not responsible for any failure to meet such industry standard requirements.

Where TI specifically promotes products as facilitating functional safety or as compliant with industry functional safety standards, such products are intended to help enable customers to design and create their own applications that meet applicable functional safety standards and requirements. Using products in an application does not by itself establish any safety features in the application. Designers must ensure compliance with safety-related requirements and standards applicable to their applications. Designer may not use any TI products in life-critical medical equipment unless authorized officers of the parties have executed a special contract specifically governing such use. Life-critical medical equipment is medical equipment where failure of such equipment would cause serious bodily injury or death (e.g., life support, pacemakers, defibrillators, heart pumps, neurostimulators, and implantables). Such equipment includes, without limitation, all medical devices identified by the U.S. Food and Drug Administration as Class III devices and equivalent classifications outside the U.S.

TI may expressly designate certain products as completing a particular qualification (e.g., Q100, Military Grade, or Enhanced Product). Designers agree that it has the necessary expertise to select the product with the appropriate qualification designation for their applications and that proper product selection is at Designers' own risk. Designers are solely responsible for compliance with all legal and regulatory requirements in connection with such selection.

Designer will fully indemnify TI and its representatives against any damages, costs, losses, and/or liabilities arising out of Designer's non-compliance with the terms and provisions of this Notice.