

CC2592 2.4GHz 范围扩展器

1 介绍

1.1 特性

- 与德州仪器 (TI) 2.4GHz 低功率 RF 器件的无缝对接
- +22dBm 输出功率
- CC2520, CC253X 和 CC85XX 上 3dB 典型经改进灵敏度
- 极少的外部组件
 - 集成开关
 - 集成匹配网络
 - 集成不平衡变压器
 - 集成电感器
 - 集成功率放大器 (PA)
 - 集成低噪声放大器 (LNA)
- 通过 HGM 端子的 LNA 增益数字控制
- 断电时 (LNA_EN = PA_EN = 0), 电流 100nA
- 低发送流耗
 - 对于 +22dBm, PAE = 34%, 电压 3V 时的电流为 155mA
- 低接收流耗
 - 针对高增益模式的 4.0mA 电流
 - 针对低增益模式的 1.9mA 电流
- 4.7dB LNA 噪声系数, 其中包括传输/接收 (T/R) 开关和外部天线
- 符合 RoHS 环保标准的 4mm x 4mm 四方扁平无引线 (QFN)-16 封装
- 2.0V 至 3.7V 工作电压
- -40°C 至 +125°C 运行温度范围

1.2 应用范围

- 所有 2.4GHz 工业、科学及医疗设备 (ISM) 频带系统
- 无线传感器网络
- 无线工业系统
- IEEE 802.15.4 和 ZigBee® 计量系统
- IEEE 802.15.4 和 ZigBee 网关
- 无线消费类电子系统
- 无线音频系统

1.3 说明

CC2592 器件是一款针对低功率和低压 2.4GHz 无线应用的经济高效且高性能的 RF 前端。

CC2592 器件是一款针对德州仪器 (TI) 所有 CC25XX 2.4GHz 低功率 RF 收发器、发射器和片上系统产品的范围扩展器。

为了增加链路预算, CC2592 器件提供一个可增加输出功率的功率放大器, 以及一个具有低噪声系数的 LNA, 以提升接收器灵敏度。

CC2592 器件提供一个极小尺寸, 高输出功率 RF 设计, 此设计采用 4mm x 4mm 四方扁平无引线 (QFN)-16 封装。

CC2592 器件包含高性能无线应用简单设计所需的 PA, LNA, 开关, RF 匹配和不平衡变压器。



1.4 功能方框图

图 1-1 显示了 CC2592 器件的简化方框图。



图 1-1. CC2592 简化方框图

修订历史记录

日期	文献编号	更改
2014 年 2 月	SWRS159	最初发布版本

2 Device Characteristics

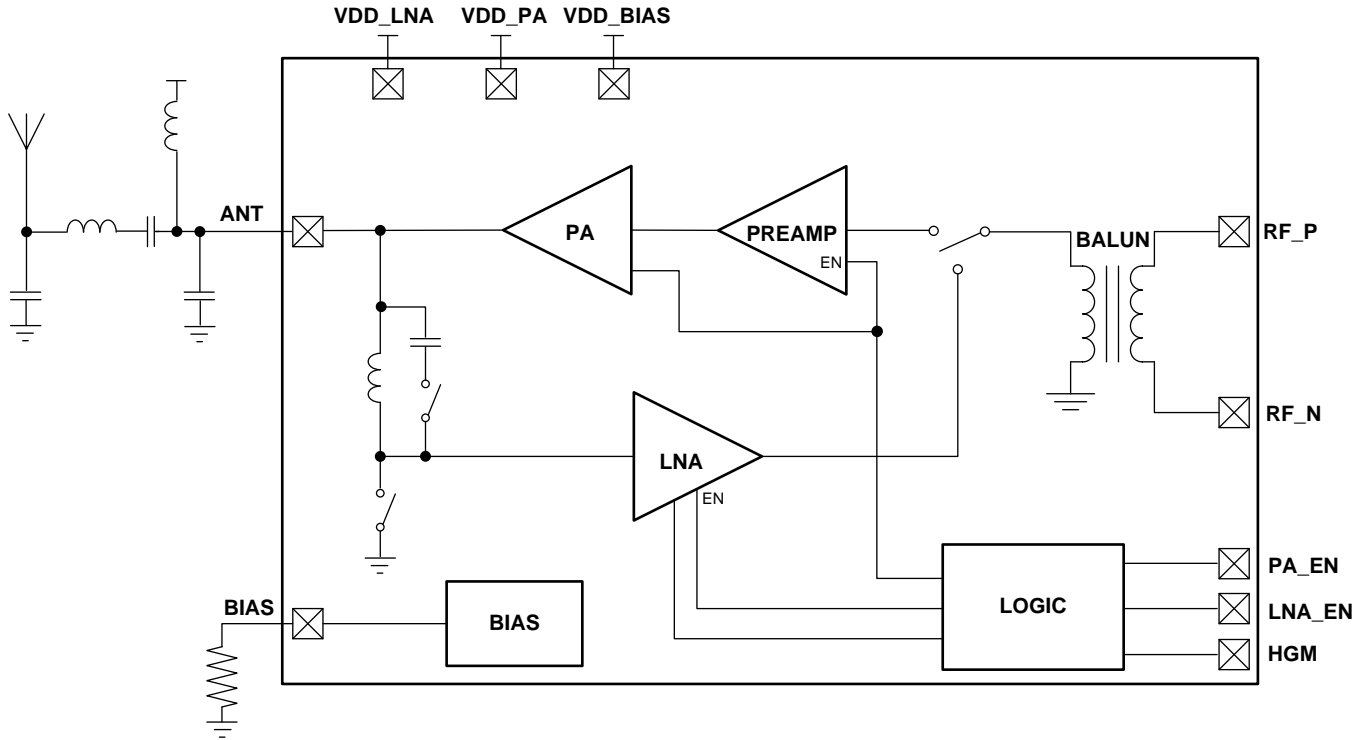
2.1 Absolute Maximum Ratings

Under no circumstances must the absolute maximum ratings be violated. Stress exceeding one or more of the limiting values may cause permanent damage to the device.

Parameter	Conditions	Value	Unit
Supply voltage	All supply terminals must have the same voltage	–0.3 to 3.8	V
Voltage on any digital terminal		–0.3 to VDD+0.3, max 3.8	V
Input RF level		+10	dBm

2.2 Handling Ratings

Under no circumstances must the handling ratings be violated. Stress exceeding one or more of the limiting values may cause permanent damage to the device.

Parameter	Conditions	Value	Unit
Storage temperature range		–50 to 150	°C
ESD	Human Body Model	2000	V
	Charge Device Model	1000	V

2.3 Recommended Operating Conditions

The operating conditions for the CC2592 device are listed below.

Parameter	Conditions	Min	Max	Unit
Ambient temperature range		–40	125	°C
Operating supply voltage		2.0	3.7	V
Operating frequency range		2400	2483.5	MHz

2.4 Electrical Characteristics

$T_c = 25^\circ\text{C}$, $V_{DD} = 3.0\text{ V}$, $f_{RF} = 2440\text{ MHz}$ (unless otherwise noted). Measured on CC2592EM reference design including external matching components.

Parameter	Test Conditions	Min	Typ	Max	Unit
Receive current, high-gain mode	HGM = 1		4		mA
Receive current, low-gain mode	HGM = 0		1.9		mA
Transmit current	$P_{OUT} = 20\text{ dBm}$		123		mA
	$P_{OUT} = 22\text{ dBm}$		155		
Transmit current	No input signal		50		mA
Power down current	EN = 0		0.1	0.3	μA
High-input level (control terminals)	PA_EN, LNA_EN, HGM	1.3		Vdd	V
Low-input level (control terminals)	PA_EN, LNA_EN, HGM			0.3	V
Power down - Receive mode switching time			1		μs
Power down - Transmit mode switching time			1		μs
RF Receive					
Gain, high-gain mode	HGM = 1		11		dB
Gain, low-gain mode	HGM = 0		6		dB
Gain variation over frequency	2400 to 2483.5 MHz, HGM = 1		2		dB
Gain variation over power supply	2.0 V to 3.7 V, HGM = 1		1.5		dB
Gain variation over temperature	-40°C to 85°C , HGM = 1		1.7		dB
Gain variation over temperature	85°C to 125°C , HGM = 1		1		dB
Noise figure, high-gain mode	HGM = 1, including internal T/R switch and external antenna match		4.7		dB
Input 1-dB compression, high-gain mode	HGM = 1		-18		dBm
Input IP3, high-gain mode	HGM = 1		-9		dBm
Input reflection coefficient, S11	HGM = 1, measured at antenna port		-15		dB
RF Transmit					
Gain			24		dB
Output power, P_{OUT}	$P_{IN} = 0.0\text{ dBm}$		20.3		dBm
	$P_{IN} = 4.0\text{ dBm}$		21.9		
Power added efficiency, PAE	$P_{OUT} = 22\text{ dBm}$		34		%
Output 1-dB compression			15		dBm
Output power variation over frequency	2400 to 2483.5 MHz, $P_{IN} = 4\text{ dBm}$		0.5		dB
Output power variation over power supply	2.0 V to 3.7 V, $P_{IN} = 4\text{ dBm}$		3.8		dB
Output power variation over temperature	-40°C to 125°C , $P_{IN} = 4\text{ dBm}$		1.7		dB
Second harmonic power	FCC requirement			-41.2	dBm
Third harmonic power	FCC requirement			-41.2	dBm
VSWR	No damage	20:1			
	Stability	7.5:1			

3 Device Information

3.1 Terminal and I/O Configuration

Figure 3-1 and Table 3-1, provide the terminal layout and description for the CC2592 device.

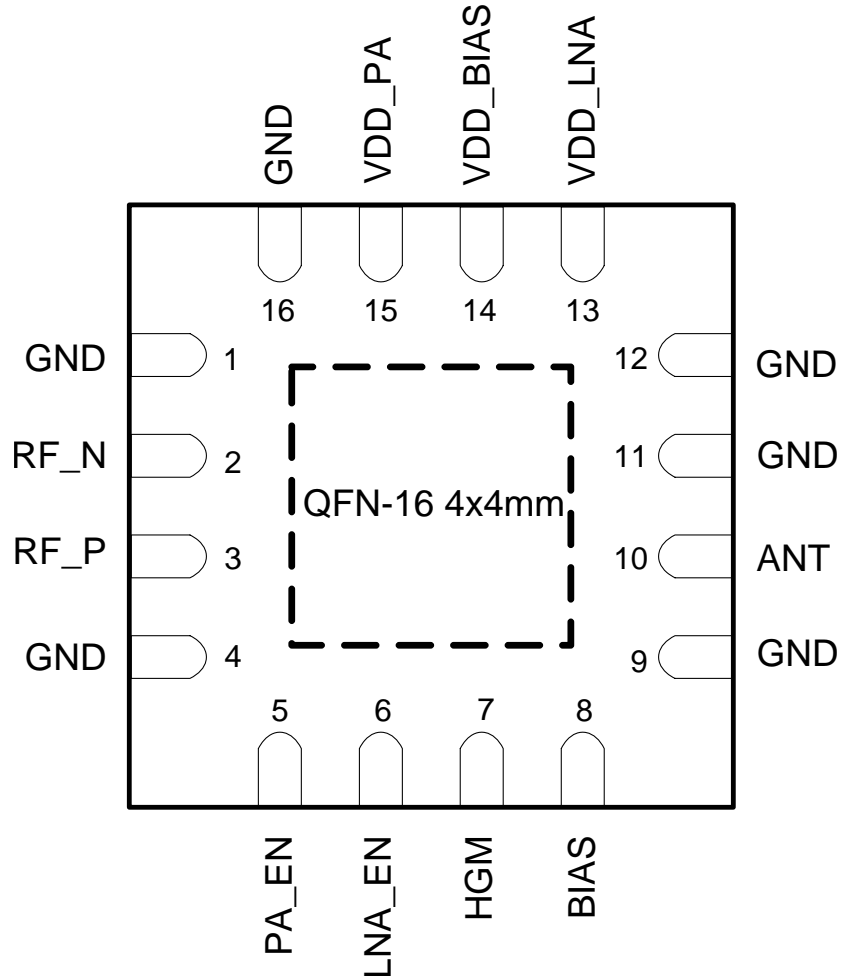

Figure 3-1. Terminal Top View

Table 3-1. Terminal Functions

Terminal		Type	Description
No.	Name		
–	GND	Ground	The exposed die attach pad must be connected to a solid ground plane. See CC2592EM reference design for the recommended layout.
1, 4, 9, 11, 12, 16	GND	Ground	Ground connections. Only terminals 9, 11, and 12 should be shorted to the die attach pad on the top PCB layer.
2	RF_N	RF	RF interface toward CC25xx device
3	RF_P	RF	RF interface toward CC25xx device
5	PA_EN	Digital input	Digital control terminal. See Table 9-1 for details.
6	LNA_EN	Digital input	Digital control terminal. See Table 9-1 or details.
7	HGM	Digital input	Digital control terminal HGM = 1 → Device in High Gain Mode HGM = 0 → Device in Low Gain Mode
8	BIAS	Analog	Biasing input. Resistor between this node and ground sets bias current for PA and LNA.
10	ANT	RF	Antenna interface
13	VDD_LNA	Power	2.0- to 3.7-V power
14	VDD_BIAS	Power	2.0- to 3.7-V power
15	VDD_PA	Power	2.0- to 3.7-V power

4 Sensitivity Improvement Example

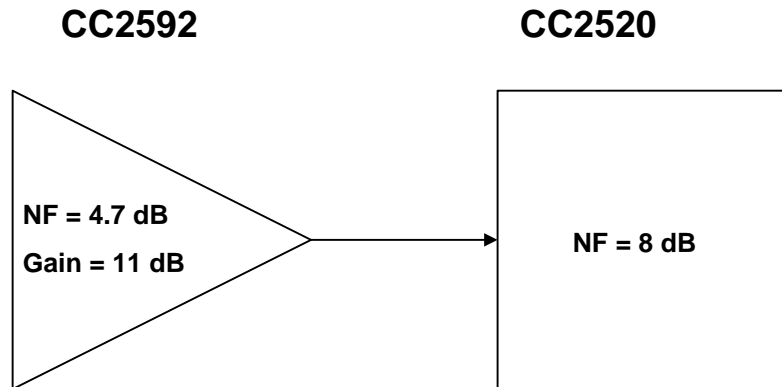

Figure 4-1.

The noise factor of a system consisting of the CC2592 device and a CC2520 device, as seen in [Figure 4-1](#) is given by:

$$F = F_1 + \frac{F_2 - 1}{G_1} = 10^{\frac{4.7}{10}} + \frac{10^{\frac{8}{10}} - 1}{10^{\frac{11}{10}}} = 3.37 \quad (1)$$

The noise figure is:

$$NF = 10 \log(F) = 10 \log(3.37) = 5.28 \text{ dB} \quad (2)$$

The noise figure is reduced from 8 dB for the CC2520 standalone to 5.28 dB for the CC2592 and CC2520 device combination, leading to a 2.72-dB theoretical improvement in sensitivity.

In practice, tests on the CC2592 and CC25XX devices show around 3-dB improvement in sensitivity. For the CC2538 and CC2592 devices, the improvement is almost 4 dB (approximately –97 dBm to –101 dBm)

5 CC2592EM Evaluation Module

Figure 5-1 shows an evaluation module circuit of the CC2592 device.

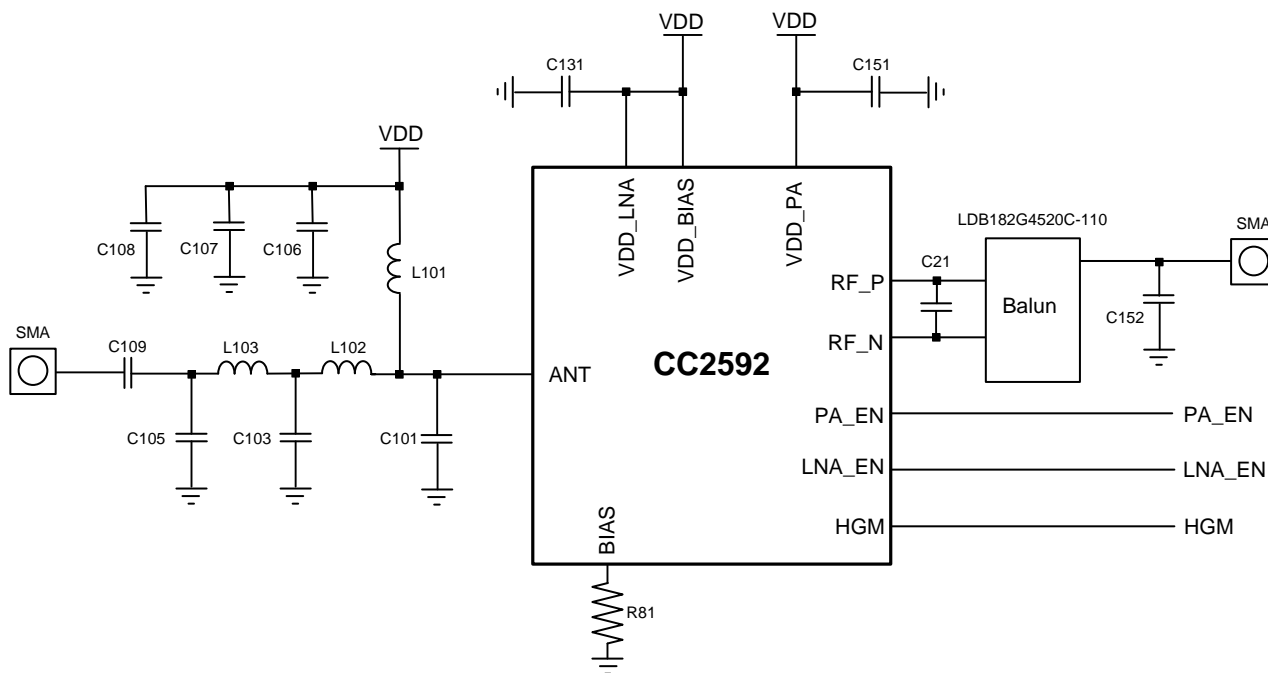

Figure 5-1. CC2592 Evaluation Module

Table 5-1 lists the materials in the CC2592 evaluation module circuit.

Table 5-1. List of Materials

Device	Function	Value
L101	PA bias inductor	4.7 nH, Multilayer chip inductor
L102	Part of antenna match	1 nH, Multilayer chip inductor
L103	Part of antenna match	1.8 nH, Multilayer chip inductor
C101	Part of antenna match	2.2-pF 0402 Chip capacitor
C103	Part of antenna match	2.2-pF 0402 Chip capacitor
C105	Part of antenna match	0.1-pF 0402 Chip capacitor
C106	Decoupling	12-pF 0402 Chip capacitor
C107	Decoupling	1-nF 0402 Chip capacitor
C108	Decoupling	1-μF 0402 Chip capacitor
C109	DC block	18-pF 0402 Chip capacitor
C21	Balun matching capacitor	0.2-pF 0402 Chip capacitor
C152	Balun matching capacitor	0.3-pF 0402 Chip capacitor
C131	Decoupling	1-nF 0402 Chip capacitor
C151	Decoupling	12-pF 0402 Chip capacitor
R81	Bias resistor	3.9 kΩ, 0402 resistor

6 Typical Characteristics

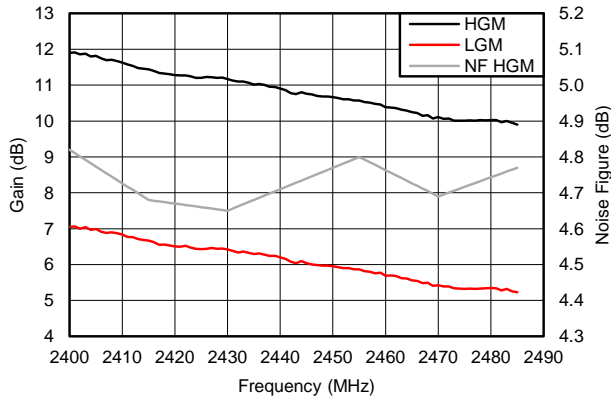

Figure 1. LNA Gain and Noise Figure Versus Frequency

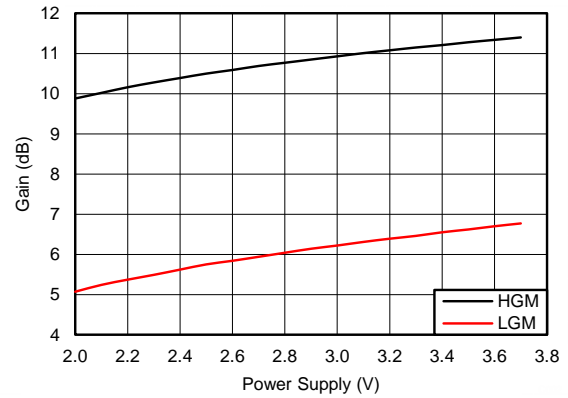

Figure 2. LNA Gain Versus Power Supply

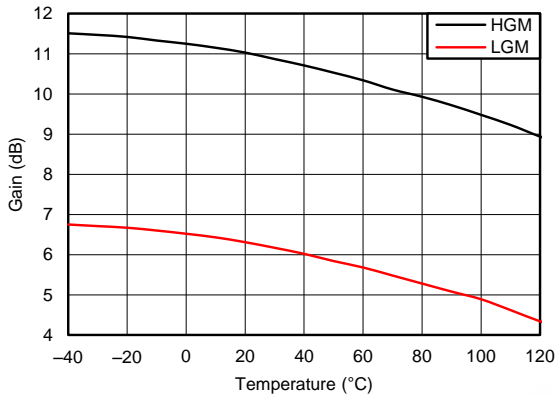

Figure 3. LNA Gain Versus Temperature

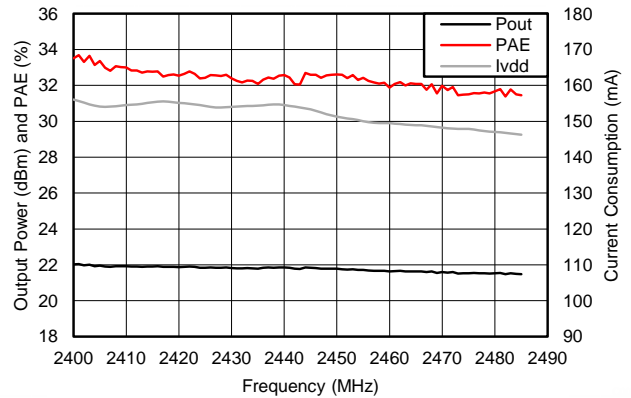

Figure 4. Output Power, PAE, and Current Consumption Versus Frequency
Input Power Level = +4 dBm

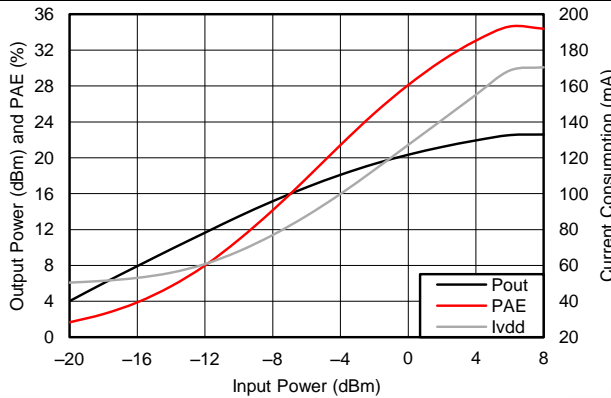

Figure 5. Output Power, PAE, and Current Consumption Versus Input Power

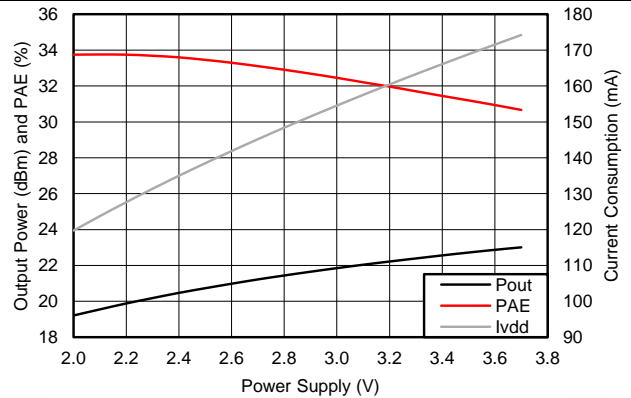

Figure 6. Output Power, PAE, and Current Consumption Versus Power Supply
Input Power Level = +4 dBm

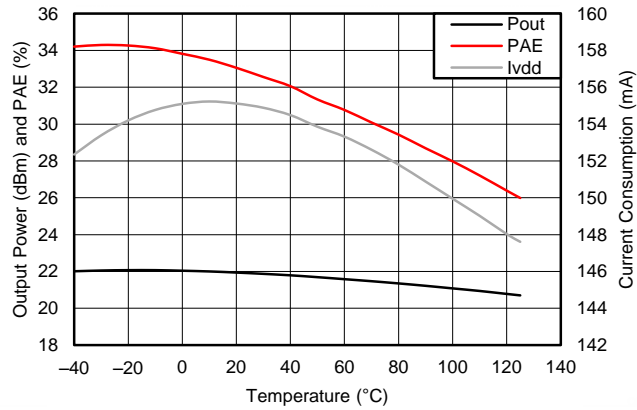

Figure 7. Output Power, PAE, and Current Consumption Versus Temperature
Input Power Level = +4 dBm

7 Controlling the Output Power from CC2592

The output power of the CC2592 device is controlled by controlling the input power. The CC2592 PA is designed to work in compression (class AB).

Driving the CC2592 device too far into saturation might result in spurious emissions and harmonics above regulatory limits. This caution should especially be considered for systems targeting a wide operating temperature range, where a combination of low temperature, low supply voltage, and a transceiver that increases output power (drive level) at low temperature, can result in high spurious emissions.

Figure 7-1 shows the maximum recommended drive level versus temperature and supply voltage.

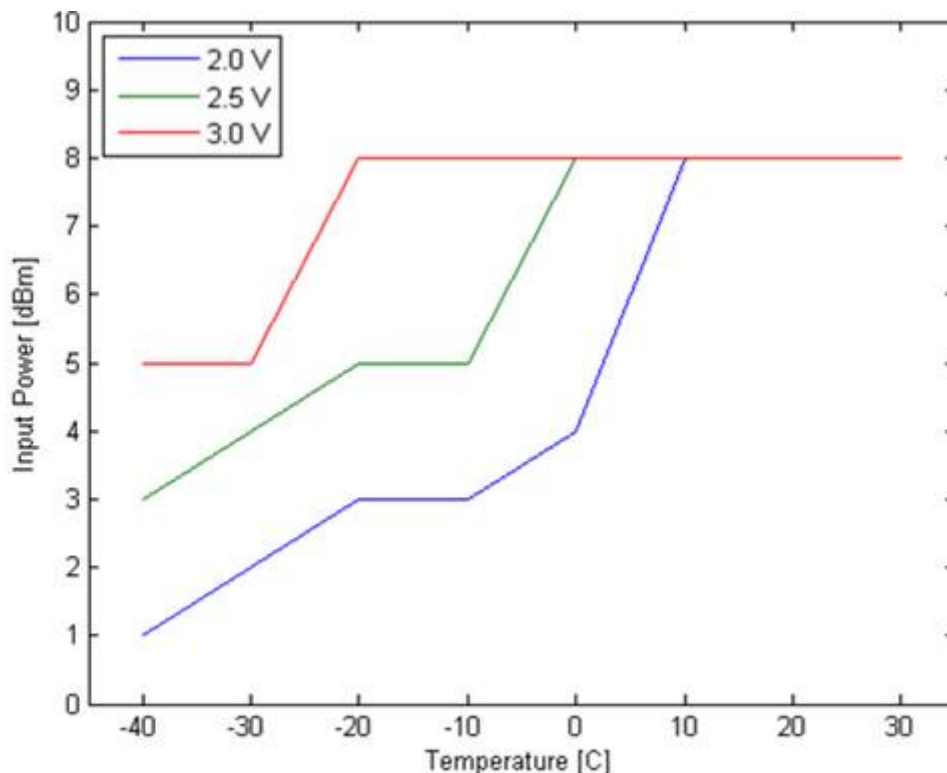

Figure 7-1. Maximum Recommended Drive Level

8 Input Levels on Control Terminals

The three digital control terminals (PA_EN, LNA_EN, and HGM) have built-in level-shifting functionality, meaning that if the CC2592 device operates off a 3.7-V supply voltage, the control terminals still sense 1.6- to 1.8-V signals as a logical 1. However, the input voltages should not have a logical 1 level that is higher than the supply.

9 Connecting the CC2592 Device to a CC25xx Device

Table 9-1 shows the control logic for connecting CC2592 to a CC25xx device.

Table 9-1. Control Logic for Connecting CC2592 to a CC25xx Device

PA_EN	LNA_EN	HGM	Mode of Operation
0	0	X	Power Down
X	1	0	RX Low-Gain Mode
X	1	1	RX High-Gain Mode
1	0	X	TX

Figure 9-1 shows the application circuit for the CC2592 and CC253X devices.

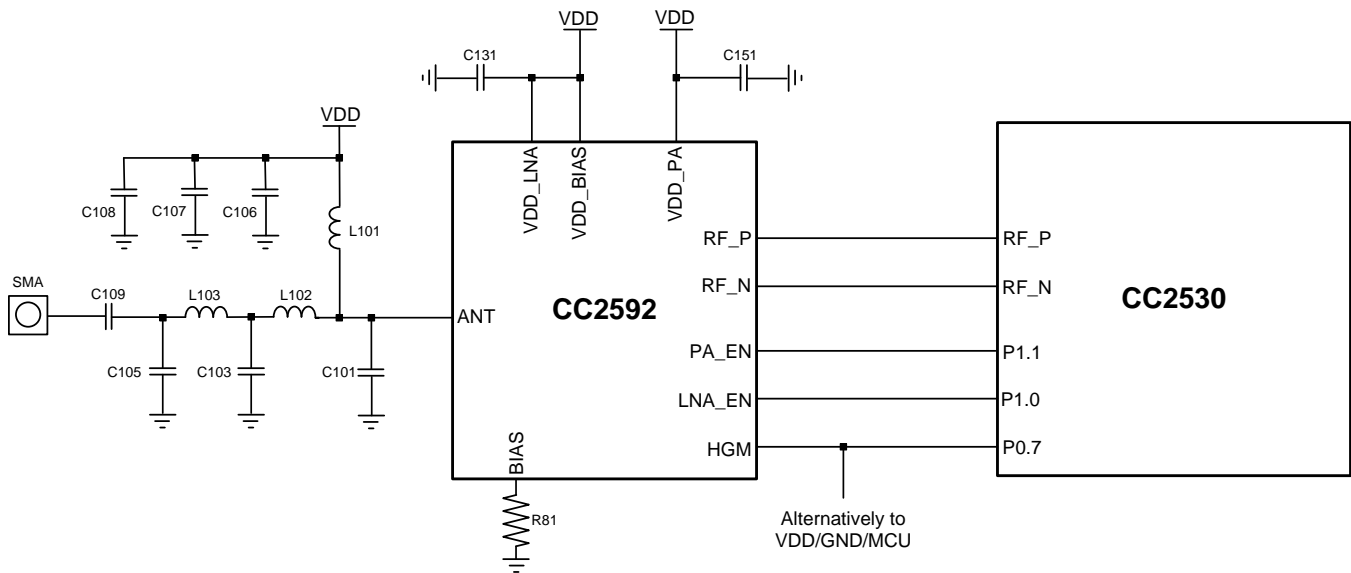

Figure 9-1. Application Circuit Example for CC2530 + CC2592

10 Device and Documentation Support

10.1 Related Links

The table below lists quick access links. Categories include technical documents, support and community resources, tools and software, and quick access to sample or buy.

Table 10-1. Related Links

PARTS	PRODUCT FOLDER	SAMPLE & BUY	TECHNICAL DOCUMENTS	TOOLS & SOFTWARE	SUPPORT & COMMUNITY
CC2592	Click here	Click here	Click here	Click here	Click here

10.2 Trademarks

ZigBee is a registered trademark of ZigBee Alliance.

10.3 Electrostatic Discharge Caution



This integrated circuit can be damaged by ESD. Texas Instruments recommends that all integrated circuits be handled with appropriate precautions. Failure to observe proper handling and installation procedures can cause damage.

ESD damage can range from subtle performance degradation to complete device failure. Precision integrated circuits may be more susceptible to damage because very small parametric changes could cause the device not to meet its published specifications.

10.4 Glossary

[SLYZ022](#) — *TI Glossary*.

This glossary lists and explains terms, acronyms and definitions.

重要声明

德州仪器(TI)及其下属子公司有权根据 JESD46 最新标准,对所提供的产品和服务进行更正、修改、增强、改进或其它更改,并有权根据 JESD48 最新标准中止提供任何产品和服务。客户在下订单前应获取最新的相关信息,并验证这些信息是否完整且是最新的。所有产品的销售都遵循在订单确认时所提供的TI 销售条款与条件。

TI 保证其所销售的组件的性能符合产品销售时 TI 半导体产品销售条件与条款的适用规范。仅在 TI 保证的范围内,且 TI 认为有必要时才会使用测试或其它质量控制技术。除非适用法律做出了硬性规定,否则没有必要对每种组件的所有参数进行测试。

TI 对应用帮助或客户产品设计不承担任何义务。客户应对其使用 TI 组件的产品和应用自行负责。为尽量减小与客户产品和应用相关的风险,客户应提供充分的设计与操作安全措施。

TI 不对任何 TI 专利权、版权、屏蔽作品权或其它与使用了 TI 组件或服务的组合设备、机器或流程相关的 TI 知识产权中授予的直接或隐含权限作出任何保证或解释。TI 所发布的与第三方产品或服务有关的信息,不能构成从 TI 获得使用这些产品或服务的许可、授权、或认可。使用此类信息可能需要获得第三方的专利权或其它知识产权方面的许可,或是 TI 的专利权或其它知识产权方面的许可。

对于 TI 的产品手册或数据表中 TI 信息的重要部分,仅在没有对内容进行任何篡改且带有相关授权、条件、限制和声明的情况下才允许进行复制。TI 对此类篡改过的文件不承担任何责任或义务。复制第三方的信息可能需要服从额外的限制条件。

在转售 TI 组件或服务时,如果对该组件或服务参数的陈述与 TI 标明的参数相比存在差异或虚假成分,则会失去相关 TI 组件或服务的所有明示或暗示授权,且这是不正当的、欺诈性商业行为。TI 对任何此类虚假陈述均不承担任何责任或义务。

客户认可并同意,尽管任何应用相关信息或支持仍可能由 TI 提供,但他们将独力负责满足与其产品及其应用中使用的 TI 产品相关的所有法律、法规和安全相关要求。客户声明并同意,他们具备制定与实施安全措施所需的全部专业技术和知识,可预见故障的危险后果、监测故障及其后果、降低有可能造成人身伤害的故障的发生机率并采取适当的补救措施。客户将全额赔偿因在此类安全关键应用中使用任何 TI 组件而对 TI 及其代理造成的任何损失。

在某些场合中,为了推进安全相关应用有可能对 TI 组件进行特别的促销。TI 的目标是利用此类组件帮助客户设计和创立其特有的可满足适用的功能安全性标准和要求的终端产品解决方案。尽管如此,此类组件仍然服从这些条款。

TI 组件未获得用于 FDA Class III (或类似的生命攸关医疗设备)的授权许可,除非各方授权官员已经达成了专门管控此类使用的特别协议。

只有那些 TI 特别注明属于军用等级或“增强型塑料”的 TI 组件才是设计或专门用于军事/航空应用或环境的。购买者认可并同意,对并非指定面向军事或航空航天用途的 TI 组件进行军事或航空航天方面的应用,其风险由客户单独承担,并且由客户独力负责满足与此类使用相关的所有法律和法规要求。

TI 已明确指定符合 ISO/TS16949 要求的产品,这些产品主要用于汽车。在任何情况下,因使用非指定产品而无法达到 ISO/TS16949 要求, TI 不承担任何责任。

	产品		应用
数字音频	www.ti.com.cn/audio	通信与电信	www.ti.com.cn/telecom
放大器和线性器件	www.ti.com.cn/amplifiers	计算机及周边	www.ti.com.cn/computer
数据转换器	www.ti.com.cn/dataconverters	消费电子	www.ti.com.cn/consumer-apps
DLP® 产品	www.dlp.com	能源	www.ti.com.cn/energy
DSP - 数字信号处理器	www.ti.com.cn/dsp	工业应用	www.ti.com.cn/industrial
时钟和计时器	www.ti.com.cn/clockandtimers	医疗电子	www.ti.com.cn/medical
接口	www.ti.com.cn/interface	安防应用	www.ti.com.cn/security
逻辑	www.ti.com.cn/logic	汽车电子	www.ti.com.cn/automotive
电源管理	www.ti.com.cn/power	视频和影像	www.ti.com.cn/video
微控制器 (MCU)	www.ti.com.cn/microcontrollers		
RFID 系统	www.ti.com.cn/rfidsys		
OMAP应用处理器	www.ti.com.cn/omap		
无线连通性	www.ti.com.cn/wirelessconnectivity	德州仪器在线技术支持社区	www.deyisupport.com

邮寄地址: 上海市浦东新区世纪大道1568号, 中建大厦32楼邮政编码: 200122
Copyright © 2014, 德州仪器半导体技术(上海)有限公司

PACKAGING INFORMATION

Orderable Device	Status (1)	Package Type	Package Drawing	Pins	Package Qty	Eco Plan (2)	Lead/Ball Finish (6)	MSL Peak Temp (3)	Op Temp (°C)	Device Marking (4/5)	Samples
CC2592RGVR	ACTIVE	VQFN	RGV	16	2500	Green (RoHS & no Sb/Br)	CU NIPDAU	Level-2-260C-1 YEAR	-40 to 125	CC2592	Samples
CC2592RGVT	ACTIVE	VQFN	RGV	16	250	Green (RoHS & no Sb/Br)	CU NIPDAU Call TI	Level-2-260C-1 YEAR	-40 to 125	CC2592	Samples

(1) The marketing status values are defined as follows:

ACTIVE: Product device recommended for new designs.

LIFEBUY: TI has announced that the device will be discontinued, and a lifetime-buy period is in effect.

NRND: Not recommended for new designs. Device is in production to support existing customers, but TI does not recommend using this part in a new design.

PREVIEW: Device has been announced but is not in production. Samples may or may not be available.

OBSOLETE: TI has discontinued the production of the device.

(2) Eco Plan - The planned eco-friendly classification: Pb-Free (RoHS), Pb-Free (RoHS Exempt), or Green (RoHS & no Sb/Br) - please check <http://www.ti.com/productcontent> for the latest availability information and additional product content details.

TBD: The Pb-Free/Green conversion plan has not been defined.

Pb-Free (RoHS): TI's terms "Lead-Free" or "Pb-Free" mean semiconductor products that are compatible with the current RoHS requirements for all 6 substances, including the requirement that lead not exceed 0.1% by weight in homogeneous materials. Where designed to be soldered at high temperatures, TI Pb-Free products are suitable for use in specified lead-free processes.

Pb-Free (RoHS Exempt): This component has a RoHS exemption for either 1) lead-based flip-chip solder bumps used between the die and package, or 2) lead-based die adhesive used between the die and leadframe. The component is otherwise considered Pb-Free (RoHS compatible) as defined above.

Green (RoHS & no Sb/Br): TI defines "Green" to mean Pb-Free (RoHS compatible), and free of Bromine (Br) and Antimony (Sb) based flame retardants (Br or Sb do not exceed 0.1% by weight in homogeneous material)

(3) MSL, Peak Temp. - The Moisture Sensitivity Level rating according to the JEDEC industry standard classifications, and peak solder temperature.

(4) There may be additional marking, which relates to the logo, the lot trace code information, or the environmental category on the device.

(5) Multiple Device Markings will be inside parentheses. Only one Device Marking contained in parentheses and separated by a "~" will appear on a device. If a line is indented then it is a continuation of the previous line and the two combined represent the entire Device Marking for that device.

(6) Lead/Ball Finish - Orderable Devices may have multiple material finish options. Finish options are separated by a vertical ruled line. Lead/Ball Finish values may wrap to two lines if the finish value exceeds the maximum column width.

Important Information and Disclaimer: The information provided on this page represents TI's knowledge and belief as of the date that it is provided. TI bases its knowledge and belief on information provided by third parties, and makes no representation or warranty as to the accuracy of such information. Efforts are underway to better integrate information from third parties. TI has taken and continues to take reasonable steps to provide representative and accurate information but may not have conducted destructive testing or chemical analysis on incoming materials and chemicals. TI and TI suppliers consider certain information to be proprietary, and thus CAS numbers and other limited information may not be available for release.

In no event shall TI's liability arising out of such information exceed the total purchase price of the TI part(s) at issue in this document sold by TI to Customer on an annual basis.

RGV (S-PVQFN-N16)

PLASTIC QUAD FLATPACK NO-LEAD

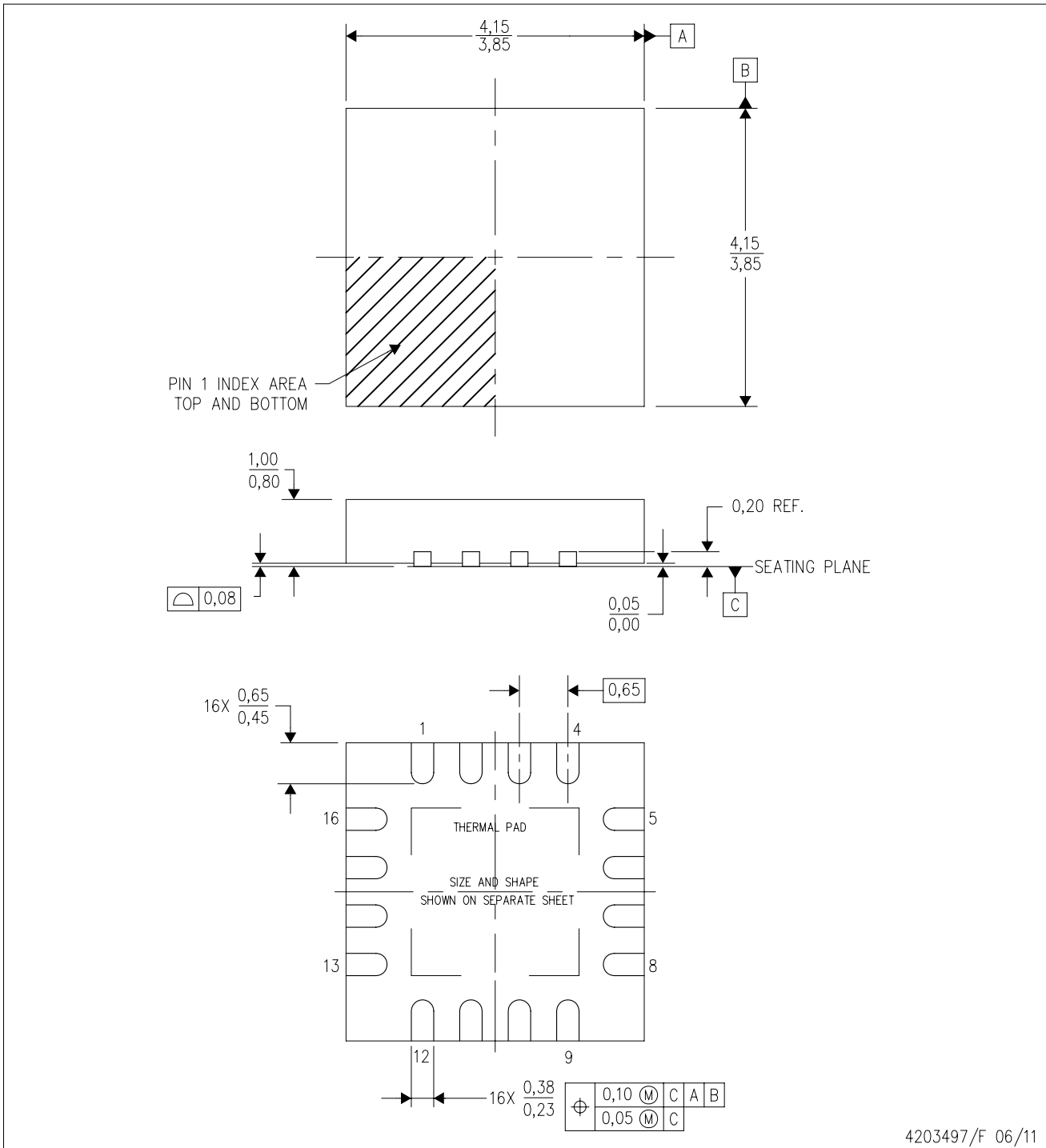

4203497/F 06/11

- NOTES:
- All linear dimensions are in millimeters. Dimensioning and tolerancing per ASME Y14.5M-1994.
 - This drawing is subject to change without notice.
 - Quad Flatpack, No-leads (QFN) package configuration.
 - The package thermal pad must be soldered to the board for thermal and mechanical performance.
 - See the additional figure in the Product Data Sheet for details regarding the exposed thermal pad features and dimensions.
 - Falls within JEDEC MO-220.

THERMAL PAD MECHANICAL DATA

RGV (S-PVQFN-N16)

PLASTIC QUAD FLATPACK NO-LEAD

THERMAL INFORMATION

This package incorporates an exposed thermal pad that is designed to be attached directly to an external heatsink. The thermal pad must be soldered directly to the printed circuit board (PCB). After soldering, the PCB can be used as a heatsink. In addition, through the use of thermal vias, the thermal pad can be attached directly to the appropriate copper plane shown in the electrical schematic for the device, or alternatively, can be attached to a special heatsink structure designed into the PCB. This design optimizes the heat transfer from the integrated circuit (IC).

For information on the Quad Flatpack No-Lead (QFN) package and its advantages, refer to Application Report, QFN/SON PCB Attachment, Texas Instruments Literature No. SLUA271. This document is available at www.ti.com.

The exposed thermal pad dimensions for this package are shown in the following illustration.

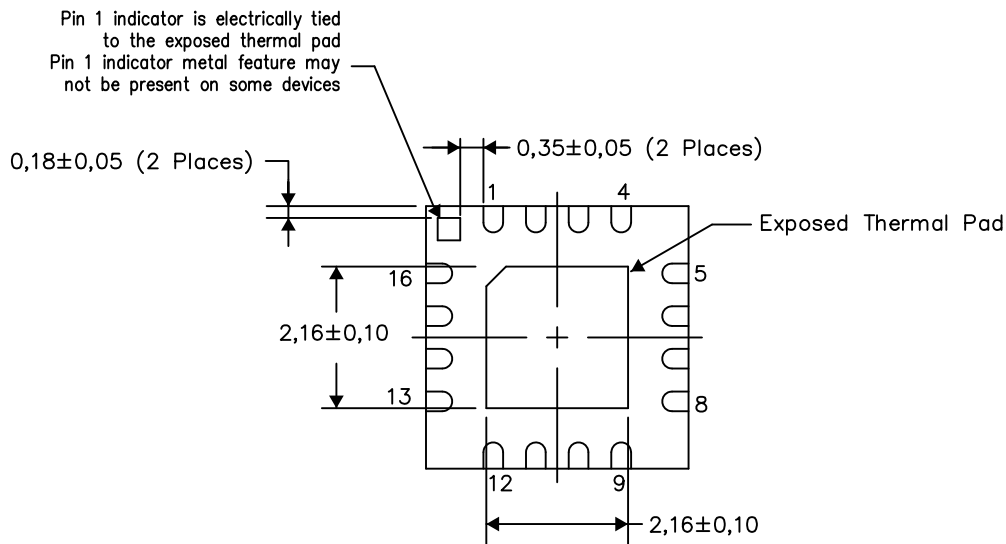

Exposed Thermal Pad Dimensions

4206351-2/L 05/13

NOTE: All linear dimensions are in millimeters

RGV (S-PVQFN-N16)

PLASTIC QUAD FLATPACK NO-LEAD

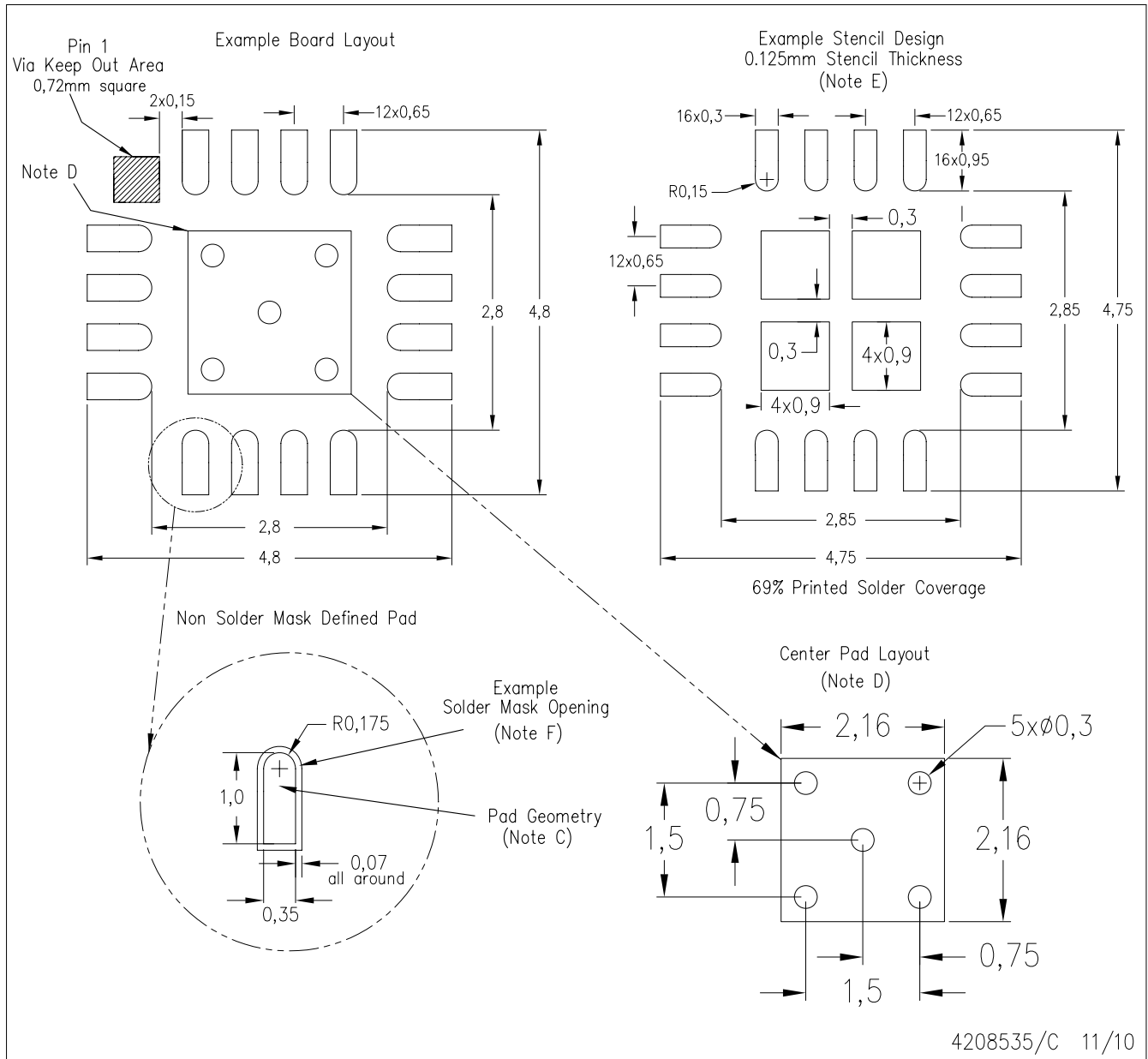

- NOTES: A. All linear dimensions are in millimeters.
 B. This drawing is subject to change without notice.
 C. Publication IPC-7351 is recommended for alternate designs.
 D. This package is designed to be soldered to a thermal pad on the board. Refer to Application Note, QFN Packages, Texas Instruments Literature No. SLUA271, and also the Product Data Sheets for specific thermal information, via requirements, and recommended board layout. These documents are available at www.ti.com <<http://www.ti.com>>.
 E. Laser cutting apertures with trapezoidal walls and also rounding corners will offer better paste release. Customers should contact their board assembly site for stencil design recommendations. Refer to IPC 7525 for stencil design considerations.
 F. Customers should contact their board fabrication site for solder mask tolerances.

重要声明

德州仪器(TI) 及其下属子公司有权根据 JESD46 最新标准, 对所提供的产品和服务进行更正、修改、增强、改进或其它更改, 并有权根据 JESD48 最新标准中止提供任何产品和服务。客户在下订单前应获取最新的相关信息, 并验证这些信息是否完整且是最新的。所有产品的销售都遵循在订单确认时所提供的TI 销售条款与条件。

TI 保证其所销售的组件的性能符合产品销售时 TI 半导体产品销售条件与条款的适用规范。仅在 TI 保证的范围内, 且 TI 认为有必要时才会使用测试或其它质量控制技术。除非适用法律做出了硬性规定, 否则没有必要对每种组件的所有参数进行测试。

TI 对应用帮助或客户产品设计不承担任何义务。客户应对其使用 TI 组件的产品和应用自行负责。为尽量减小与客户产品和应用相关的风险, 客户应提供充分的设计与操作安全措施。

TI 不对任何 TI 专利权、版权、屏蔽作品权或其它与使用了 TI 组件或服务的组合设备、机器或流程相关的 TI 知识产权中授予的直接或间接版权限作出任何保证或解释。TI 所发布的与第三方产品或服务有关的信息, 不能构成从 TI 获得使用这些产品或服务的许可、授权、或认可。使用此类信息可能需要获得第三方的专利权或其它知识产权方面的许可, 或是 TI 的专利权或其它知识产权方面的许可。

对于 TI 的产品手册或数据表中 TI 信息的重要部分, 仅在没有对内容进行任何篡改且带有相关授权、条件、限制和声明的情况下才允许进行复制。TI 对此类篡改过的文件不承担任何责任或义务。复制第三方的信息可能需要服从额外的限制条件。

在转售 TI 组件或服务时, 如果对该组件或服务参数的陈述与 TI 标明的参数相比存在差异或虚假成分, 则会失去相关 TI 组件或服务的所有明示或暗示授权, 且这是不正当的、欺诈性商业行为。TI 对任何此类虚假陈述均不承担任何责任或义务。

客户认可并同意, 尽管任何应用相关信息或支持仍可能由 TI 提供, 但他们将独自负责满足与其产品及其应用中使用 TI 产品相关的所有法律、法规和安全相关要求。客户声明并同意, 他们具备制定与实施安全措施所需的全部专业技术和知识, 可预见故障的危险后果、监测故障及其后果、降低有可能造成人身伤害的故障的发生机率并采取适当的补救措施。客户将全额赔偿因在此类安全关键应用中使用任何 TI 组件而对 TI 及其代理造成的任何损失。

在某些场合中, 为了推进安全相关应用有可能对 TI 组件进行特别的促销。TI 的目标是利用此类组件帮助客户设计和创立其特有的可满足适用的功能安全性标准和要求的终端产品解决方案。尽管如此, 此类组件仍然服从这些条款。

TI 组件未获得用于 FDA Class III (或类似的生命攸关医疗设备) 的授权许可, 除非各方授权官员已经达成了专门管控此类使用的特别协议。

只有那些 TI 特别注明属于军用等级或“增强型塑料”的 TI 组件才是设计或专门用于军事/航空应用或环境的。购买者认可并同意, 对并非指定面向军事或航空航天用途的 TI 组件进行军事或航空航天方面的应用, 其风险由客户单独承担, 并且由客户独自负责满足与此类使用相关的所有法律和法规要求。

TI 已明确指定符合 ISO/TS16949 要求的产品, 这些产品主要用于汽车。在任何情况下, 因使用非指定产品而无法达到 ISO/TS16949 要求, TI 不承担任何责任。

	产品		应用
数字音频	www.ti.com.cn/audio	通信与电信	www.ti.com.cn/telecom
放大器和线性器件	www.ti.com.cn/amplifiers	计算机及周边	www.ti.com.cn/computer
数据转换器	www.ti.com.cn/dataconverters	消费电子	www.ti.com.cn/consumer-apps
DLP® 产品	www.dlp.com	能源	www.ti.com.cn/energy
DSP - 数字信号处理器	www.ti.com.cn/dsp	工业应用	www.ti.com.cn/industrial
时钟和计时器	www.ti.com.cn/clockandtimers	医疗电子	www.ti.com.cn/medical
接口	www.ti.com.cn/interface	安防应用	www.ti.com.cn/security
逻辑	www.ti.com.cn/logic	汽车电子	www.ti.com.cn/automotive
电源管理	www.ti.com.cn/power	视频和影像	www.ti.com.cn/video
微控制器 (MCU)	www.ti.com.cn/microcontrollers		
RFID 系统	www.ti.com.cn/rfidsys		
OMAP应用处理器	www.ti.com.cn/omap		
无线连通性	www.ti.com.cn/wirelessconnectivity	德州仪器在线技术支持社区	www.deyisupport.com

Mailing Address: Texas Instruments, Post Office Box 655303, Dallas, Texas 75265
Copyright © 2016, Texas Instruments Incorporated