

bq24157S 1.55A 完全集成开关模式单节锂离子充电器

具有完全 USB 兼容且支持 USB-OTG

1 特性

- 集成功率场效应晶体管 (FET)，以支持高达 1.55A 的充电率
- 展频频率控制，以提高电磁干扰 (EMI) 性能
- 高精度电压和电流调节
 - 输入电流调节精度： $\pm 5\%$ (100mA 和 500mA)
 - 充电电压调节精度： $\pm 0.5\%$ (25°C)， $\pm 1\%$ (0°C 至 125°C)
 - 充电电流调节精度： $\pm 5\%$
- 在无电池情况下，针对 GSM 校准的厂家测试模式
- 基于动态电源管理的输入电压 (VIN DPM)
- 故障适配器检测和抑制
- 用于最大充电电压和电流限制的安全限制寄存器
- 用于单节锂离子和锂聚合物电池组的高效微型 USB / 交流电池充电器
- 20V 额定最大绝对输入电压
- 6.5V 最大运行输入电压
- 通过 I²C 兼容接口的可编程充电参数 (高达 3.4Mbps)：
 - 输入电流限制
 - VIN DPM 阈值
 - 快速充电/终止电流
 - 充电稳压电压 (3.5 至 4.44V)
 - 低充电电流模式启用/禁用
 - 带有复位控制的安全定时器
 - 终止使能/禁用
- 同步固定频率脉宽调制 (PWM) 控制器，运行在 3MHz 上时，占空比 0% 至 99.5%
- 针对低功耗的自动高阻抗模式
- 稳健耐用的保护
 - 反向漏电保护防止电池亏电
 - 热调节和保护
 - 输入/输出过压保护
- 针对充电和故障的状态输出
- 支持 USB 的引导序列
- 自动充电
- 无电池的加电系统
- 针对 USB OTG 的升压模式操作：
 - 输入电压范围 (电池供电)：

3.2 至 4.5V

- 针对 V_{BUS} 的输出：5.05V, 350mA
- 2.25mm x 2.65mm, 20 引脚芯片尺寸球状引脚栅格阵列 (DSBGA) 封装
- 与 bq24157 和 bq24158 引脚到引脚兼容

2 应用范围

- 手机和智能电话
- MP3 播放器
- 手持设备

3 说明

bq24157S 是一款针对广泛便携式应用中所用单节锂离子和锂聚合物电池的紧凑、灵活、高效、支持 USB 开关模式充电管理的器件。可通过一个 I²C 接口对充电参数进行编程。IC 将同步 PWM 控制器，功率金属氧化物半导体场效应晶体管 (MOSFET)，输入电流检测，高精度电流和电压调节以及充电终止功能集成到小型 DSBGA 封装中。

IC 分三个阶段对电池进行充电：调节、恒定电流和恒定电压。输入电流被自动限制在主机设定的值上。

器件信息(1)

器件型号	封装	封装尺寸 (标称值)
bq24157S	DSBGA (20)	2.25mm x 2.65mm

(1) 要了解所有可用封装，请见数据表末尾的可订购产品附录。

典型应用电路

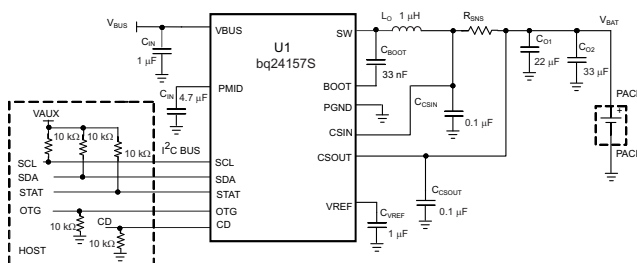

- A. 使用 $R_{SNS} = 68m\Omega$ 来设定高达 1.25A 的充电电流，使用 $R_{SNS} = 55m\Omega$ 来设定高达 1.55A 充电电流。要获得详细操作指南，请参考 [Detailed Design Procedure](#)。



目录

1	特性	1	8.4	Device Functional Modes	24
2	应用范围	1	8.5	Register Maps	26
3	说明	1	9	Application and Implementation	29
4	修订历史记录	2	9.1	Application Information	29
5	说明 (续)	3	9.2	Typical Application	29
6	Pin Configuration and Functions	3	10	Power Supply Recommendations	34
7	Specifications	4	10.1	System Load After Sensing Resistor	34
7.1	Absolute Maximum Ratings	4	11	Layout	36
7.2	Handling Ratings	4	11.1	Layout Guidelines	36
7.3	Recommended Operating Conditions	4	11.2	Layout Example	36
7.4	Thermal Information	4	12	器件和文档支持	38
7.5	Electrical Characteristics	5	12.1	器件支持	38
7.6	Typical Performance Characteristics	8	12.2	文档支持	38
8	Detailed Description	11	12.3	商标	38
8.1	Overview	11	12.4	静电放电警告	38
8.2	Functional Block Diagrams	12	12.5	术语表	38
8.3	Feature Description	14	13	机械封装和可订购信息	39
			13.1	封装概要	39

4 修订历史记录

Changes from Original (February 2013) to Revision A

Page

- 已将数据表更新为全新 TI 标准：已添加章节并重新排序文档流程 **1**

5 说明 (续)

根据电池电压和用户可选最小电流水平，充电被终止。一个带有复位控制的安全定时器为 I²C 接口提供安全备份。

正常运行期间，如果电池电压下降到低于一个内部阈值，IC 自动重新启动充电周期并在输入电源被移除后，自动进入睡眠模式或者高阻抗模式。充电状态可通过 I²C 接口报告给主机。充电过程中，IC 监视其结温 (T_J) 并且在 T_J 增加到大约 125°C 时减少充电电流。为了支持 USB OTG 器件，通过提升电池电压，bq24157S 能够提供 VBUS (5.05V)。此 IC 采用 20 引脚 DSBGA 封装。

6 Pin Configuration and Functions

20-Bump DSBGA Package
(Top View)

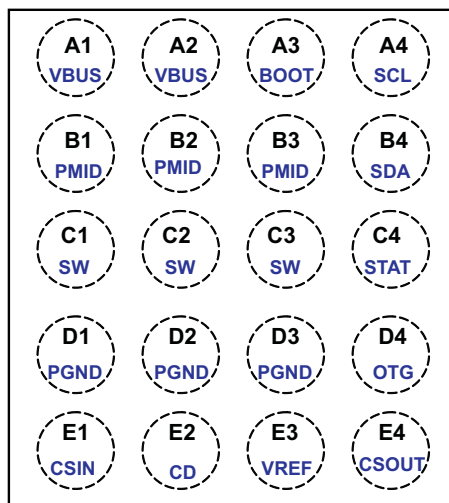

Pin Functions

PIN		I/O	DESCRIPTION
NAME	NUMBER		
BOOT	A3	I/O	Bootstrap capacitor connection for the high-side FET gate driver. Connect a 33-nF ceramic capacitor (voltage rating ≥10 V) from BOOT pin to SW pin.
CD	E2	I	Charge disable control pin. CD = 0, charge is enabled. CD = 1, charge is disabled and VBUS pin is high impedance to GND. In 15-minute mode, Setting CD = 1 resets the 15-minute timer; while in 32-second mode, setting CD = 1 will not reset the 32-second timer.
CSIN	E1	I	Charge current-sense input. Battery current is sensed across an external sense resistor. A 0.1-μF ceramic capacitor to PGND is required.
CSOUT	E4	I	Battery voltage and current sense input. Bypass it with a ceramic capacitor (minimum 0.1 μF) to PGND if there are long inductive leads to battery.
OTG	D4	I	Boost mode enable control or input current limiting selection pin. When OTG is in active status, the device is forced to operate in boost mode. It has higher priority over I ² C control and can be disabled using the control register. At POR while in 15-minute mode, the OTG pin is the default to be used as the input current limiting selection pin. The I ² C register is ignored at startup. When OTG = High, I _{IN_LIMIT} = 500 mA and when OTG = Low, I _{IN_LIMIT} = 100 mA.
PGND	D1, D2, D3		Power ground
PMID	B1, B2, B3	I/O	Connection point between reverse blocking FET and high-side switching FET. Bypass it with a minimum of 3.3-μF capacitor from PMID to PGND.
SCL	A4	I	I ² C interface clock. Connect a 10-kΩ pullup resistor to 1.8-V rail (V _{AUX} = V _{CC_HOST})
SDA	B4	I/O	I ² C interface data. Connect a 10-kΩ pullup resistor to 1.8-V rail (V _{AUX} = V _{CC_HOST})
STAT	C4	O	Charge status pin. Pull low when charge in progress. Open drain for other conditions. During faults, a 128-μs pulse is sent out. STAT pin can be disabled by the EN_STAT bit in control register. STAT can be used to drive a LED or communicate with a host processor.
SW	C1, C2, C3	O	Internal switch to output inductor connection
VBUS	A1, A2	I/O	Charger input voltage. Bypass it with a 1-μF ceramic capacitor from VBUS to PGND. It also provides power to the load during boost mode.
VREF	E3	O	Internal bias regulator voltage. Connect a 1-μF ceramic capacitor from this output to PGND. TI does not recommend an external load on VREF.

7 Specifications

7.1 Absolute Maximum Ratings^{(1) (2)}

over operating free-air temperature (unless otherwise noted)

		MIN	MAX	UNIT
Supply voltage (with respect to PGND ⁽³⁾)	VBUS; $V_{PMID} \geq V_{BUS} - 0.3\text{ V}$	-2	20	V
Input voltage (with respect to PGND ⁽³⁾)	SCL, SDA, OTG, SLRST, CSIN, CSOUT, CD	-0.3	7	V
Output voltage (with respect to PGND ⁽³⁾)	PMID, STAT	-0.3	20	V
	VREF	-0.3	7	V
	SW, BOOT	-0.7	20	V
Voltage difference between CSIN and CSOUT inputs ($V_{(CSIN)} - V_{(CSOUT)}$)			±7	V
Voltage difference between BOOT and SW inputs ($V_{(BOOT)} - V_{(SW)}$)		-0.3	7	V
Voltage difference between VBUS and PMID inputs ($V_{(VBUS)} - V_{(PMID)}$)		-7	0.7	V
Voltage difference between PMID and SW inputs ($V_{(PMID)} - V_{(SW)}$)		-0.7	20	V
Output sink	STAT	10	10	mA
Output current (average)	SW		1.55 ⁽²⁾	A
T _A	Operating free-air temperature range	-30	85	°C
T _J	Junction temperature	-40	125	°C

- (1) Stresses beyond those listed under *absolute maximum ratings* may cause permanent damage to the device. These are stress ratings only, and functional operation of the device at these or any other conditions beyond those indicated under *recommended operating conditions* is not implied. Exposure to absolute-maximum-rated conditions for extended periods may affect device reliability. All voltage values are with respect to the network ground terminal unless otherwise noted.
- (2) Duty cycle for output current should be less than 50% for 10-year lifetime when output current is above 1.5 A.
- (3) All voltages are with respect to PGND if not specified. Currents are positive into, negative out of the specified terminal, if not specified. For thermal limitations and considerations of packages, see [机械封装和可订购信息](#).

7.2 Handling Ratings

		MIN	MAX	UNIT
T _{stg}	Storage temperature range	-45	150	°C
V _(ESD)	Electrostatic discharge	Human body model (HBM), per ANSI/ESDA/JEDEC JS-001, all pins ⁽¹⁾		V
		Charged device model (CDM), per JEDEC specification JESD22-C101, all pins ⁽²⁾		
		0	2000	
		0	500	

- (1) JEDEC document JEP155 states that 500-V HBM allows safe manufacturing with a standard ESD control process.
- (2) JEDEC document JEP157 states that 250-V CDM allows safe manufacturing with a standard ESD control process.

7.3 Recommended Operating Conditions

		MIN	NOM	MAX	UNIT
V _{BUS}	Supply voltage, bq24157S	4		6 ⁽¹⁾	V
T _J	Operating junction temperature range	-40		125	°C

- (1) The inherent switching noise voltage spikes should not exceed the absolute maximum rating on either the BOOST or SW pins. A *tight* layout minimizes switching noise.

7.4 Thermal Information

THERMAL METRIC ⁽¹⁾		bq24157S		UNIT
		YFF (20 PINS)		
R _{θJA}	Junction-to-ambient thermal resistance	85		°C/W
R _{θJC(top)}	Junction-to-case (top) thermal resistance	25		
R _{θJB}	Junction-to-board thermal resistance	55		
ψ _{JT}	Junction-to-top characterization parameter	4		
ψ _{JB}	Junction-to-board characterization parameter	50		
R _{θJC(bot)}	Junction-to-case (bottom) thermal resistance	N/A		

- (1) For more information about traditional and new thermal metrics, see the *IC Package Thermal Metrics* application report, [SPRA953](#).

7.5 Electrical Characteristics

Circuit of Figure 28, VBUS = 5 V, HZ_MODE = 0, OPA_MODE = 0 (CD = 0), T_J = -40°C to 125°C, T_J = 25°C for typical values (unless otherwise noted)

PARAMETER		TEST CONDITIONS	MIN	TYP	MAX	UNIT
INPUT CURRENTS						
I _(VBUS)	VBUS supply current control	VBUS > VBUS(min), PWM switching		10		mA
		VBUS > VBUS(min), PWM not switching			5	
		0°C < T _J < 85°C, CD = 1 or HZ_MODE = 1		15	23	μA
I _{l_{gk}}	Leakage current from battery to VBUS pin	0°C < T _J < 85°C, V _(CSOUT) = 4.2 V, high impedance mode, VBUS = 0 V			5	μA
	Battery discharge current in high impedance mode, (CSIN, CSOUT, SW pins)	0°C < T _J < 85°C, V _(CSOUT) = 4.2 V, high impedance mode, V = 0 V, SCL, SDA, OTG = 0 V or 1.8 V			23	μA
VOLTAGE REGULATION						
V _(OREG)	Output regulation voltage programmable range	Operating in voltage regulation, programmable	3.5		4.44	V
	Voltage regulation accuracy	T _A = 25°C	-0.5%		0.5%	
		T _A = -40°C to 125°C	-1%		1%	
CURRENT REGULATION (FAST CHARGE)						
I _{O(CHARGE)}	Output charge current programmable range	V _(LOWV) ≤ V _(CSOUT) < V _(OREG) , VBUS > V _(SLP) , R _(SNS) = 68 mΩ, LOW_CHG = 0, Programmable	550		1250	mA
	Low charge current (default after POR in 15 min mode)	V _(LOWV) ≤ V _(CSOUT) < V _(OREG) , VBUS > V _(SLP) , R _(SNS) = 68 mΩ, LOW_CHG = 1, OTG = High		325	350	
			V _(LOWV) ≤ V _(CSOUT) < V _(OREG) , VBUS > V _(SLP) , R _(SNS) = 68 mΩ, LOW_CHG = 0, OTG = High		550	569
	Regulation accuracy of the voltage across R _(SNS) (for charge current regulation) V _(IREG) = I _{O(CHARGE)} × R _(SNS)	37.4 mV ≤ V _(IREG) < 44.2 mV	-3.5%		3.5%	
		44.2 mV ≤ V _(IREG)	-3%		3%	
WEAK BATTERY DETECTION						
V _(LOWV)	Weak battery voltage threshold programmable range ² (1)	Adjustable using I ² C control	3.4		3.7	V
	Weak battery voltage accuracy		-5%		5%	
	Hysteresis for V _(LOWV)	Battery voltage falling		100		mV
	Deglintch time for weak battery threshold	Rising voltage, 2-mV overdrive, t _{RISE} = 100 ns		30		ms
CD, OTG, AND SLRST PIN LOGIC LEVEL						
V _{IL}	Input low threshold level				0.4	V
V _{IH}	Input high threshold level		1.3			V
I _(bias)	Input bias current	Voltage on control pin is 5 V			1.0	μA
CHARGE TERMINATION DETECTION						
I _(TERM)	Termination charge current programmable range	V _(CSOUT) > V _(OREG) - V _(RCH) , VBUS > V _(SLP) , R _(SNS) = 68 mΩ, programmable	50		400	mA
	Deglintch time for charge termination	Both rising and falling, 2-mV overdrive, t _{RISE} , t _{FALL} = 100 ns		30		
	Regulation accuracy for termination current across R _(SNS) V _(IREG_TERM) = I _{O(TERM)} × R _(SNS)	3.4 mV ≤ V _(IREG_TERM) ≤ 6.8 mV	-15%		15%	
		6.8 mV < V _(IREG_TERM) ≤ 17 mV	-10%		10%	
		17 mV < V _(IREG_TERM) ≤ 27.2 mV	-5.5%		5.5%	
BAD ADAPTOR DETECTION						
V _{IN(min)}	Input voltage lower limit	Bad adaptor detection	3.6	3.8	4.0	V
	Deglintch time for VBUS rising above V _{IN(min)}	Rising voltage, 2-mV overdrive, t _{RISE} = 100 ns		30		ms
	Hysteresis for V _{IN(min)}	Input voltage rising	100		200	mV
I _{SHORT}	Current source to GND	During bad adaptor detection	20	30	40	mA
t _{INT}	Detection Interval	Input power source detection		2		s
INPUT BASED DYNAMIC POWER MANAGEMENT						
V _{IN_DPM}	Input Voltage DPM threshold programmable range		4.2		4.76	V
	VIN DPM threshold accuracy		-3%		1%	

(1) While in 15-minute mode, if a battery that is charged to a voltage higher than this voltage is inserted, the charger enters Hi-Z mode and awaits I²C commands.

Electrical Characteristics (continued)

Circuit of [Figure 28](#), $V_{BUS} = 5\text{ V}$, $HZ_MODE = 0$, $OPA_MODE = 0$ ($CD = 0$), $T_J = -40^\circ\text{C}$ to 125°C , $T_J = 25^\circ\text{C}$ for typical values (unless otherwise noted)

PARAMETER		TEST CONDITIONS	MIN	TYP	MAX	UNIT	
INPUT CURRENT LIMITING							
I_{IN_LIMIT}	Input current limiting threshold	$I_{IN} = 100\text{ mA}$	$T_J = 0^\circ\text{C}$ to 125°C	88	93	98	mA
			$T_J = -40^\circ\text{C}$ to 125°C	86	93	98	
		$I_{IN} = 500\text{ mA}$	$T_J = 0^\circ\text{C}$ to 125°C	450	475	500	mA
			$T_J = -40^\circ\text{C}$ to 125°C	440	475	500	
VREF BIAS REGULATOR							
V_{REF}	Internal bias regulator voltage	$V_{BUS} > V_{IN(min)}$ or $V_{(CSOUT)} > V_{BUS(min)}$, $I_{(VREF)} = 1\text{ mA}$, $C_{(VREF)} = 1\text{ }\mu\text{F}$	2		6.5	V	
	V_{REF} output short current limit			30		mA	
BATTERY RECHARGE THRESHOLD							
$V_{(RCH)}$	Recharge threshold voltage	Below $V_{(OREG)}$	100	120	150	mV	
	Deglitch time	$V_{(SCOUT)}$ decreasing below threshold, $t_{FALL} = 100\text{ ns}$, 10-mV overdrive		130		ms	
STAT OUTPUTS							
$V_{OL(STAT)}$	Low-level output saturation voltage, STAT pin	$I_O = 10\text{ mA}$, sink current			0.55	V	
	High-level leakage current for STAT	Voltage on STAT pin is 5 V			1	μA	
I²C BUS LOGIC LEVELS AND TIMING CHARACTERISTICS							
V_{OL}	Output low threshold level	$I_O = 10\text{ mA}$, sink current			0.4	V	
V_{IL}	Input low threshold level	$V_{(pullup)} = 1.8\text{ V}$, SDA and SCL			0.4	V	
V_{IH}	Input high threshold level	$V_{(pullup)} = 1.8\text{ V}$, SDA and SCL	1.2			V	
$I_{(BIAS)}$	Input bias current	$V_{(pullup)} = 1.8\text{ V}$, SDA and SCL			1	μA	
$f_{(SCL)}$	SCL clock frequency				3.4	MHz	
BATTERY DETECTION							
$I_{(DETECT)}$	Battery detection current before charge done (sink current) ⁽²⁾	Begins after termination detected, $V_{(CSOUT)} \leq V_{(OREG)}$		-0.5		mA	
t_{DETECT}	Battery detection time			262		ms	
SLEEP COMPARATOR							
$V_{(SLP)}$	Sleep-mode entry threshold, $V_{BUS} - V_{CSOUT}$	$2.3\text{ V} \leq V_{(CSOUT)} \leq V_{(OREG)}$, V_{BUS} falling	0	40	100	mV	
$V_{(SLP_EXIT)}$	Sleep-mode exit hysteresis	$2.3\text{ V} \leq V_{(CSOUT)} \leq V_{(OREG)}$	140	200	260	mV	
	Deglitch time for V_{BUS} rising above $V_{(SLP)} + V_{(SLP_EXIT)}$	Rising voltage, 2-mV overdrive, $t_{RISE} = 100\text{ ns}$		30		ms	
UNDERVOLTAGE LOCKOUT (UVLO)							
UVLO	IC active threshold voltage	V_{BUS} rising – exits UVLO	3.05	3.3	3.55	V	
UVLO _(HYS)	IC active hysteresis	V_{BUS} falling below UVLO – enters UVLO	120	150		mV	
	Power up delay			140		ms	
PWM							
	Voltage from BOOT pin to SW pin	During charge or boost operation			6.5	V	
	Internal top reverse blocking MOSFET on-resistance	$I_{IN(LIMIT)} = 500\text{ mA}$, measured from V_{BUS} to PMID		180	250	m Ω	
	Internal top N-channel switching MOSFET on-resistance	Measured from PMID to SW, $V_{BOOT} - V_{SW} = 4\text{ V}$		120	250		
	Internal bottom N-channel MOSFET on-resistance	Measured from SW to PGND		110	210		
$f_{(OSC)}$	Oscillator frequency			3.0		MHz	
	Frequency accuracy		-10%		10%		
$D_{(MAX)}$	Maximum duty cycle			99.5%		mA	
$D_{(MIN)}$	Minimum duty cycle		0				
	Synchronous mode to non-synchronous mode transition current threshold ⁽²⁾	Low-side MOSFET cycle-by-cycle current sensing		100			

(2) Bottom N-channel FET always turns on for approximately 30 ns, and then turns off if current is too low.

Electrical Characteristics (continued)

Circuit of Figure 28, VBUS = 5 V, HZ_MODE = 0, OPA_MODE = 0 (CD = 0), T_J = –40°C to 125°C, T_J = 25°C for typical values (unless otherwise noted)

PARAMETER		TEST CONDITIONS	MIN	TYP	MAX	UNIT
CHARGE MODE PROTECTION						
V _{OVP_IN_USB}	Input VBUS OVP threshold voltage	VBUS threshold to turn off converter during charge	6.3	6.5	6.7	V
V _{OVP}	Output OVP threshold voltage	V _(CSOUT) threshold over V _(OREG) to turn off charger during charge	110	117	121	%V _{OREG}
	V _(OVP) hysteresis	Lower limit for V _(CSOUT) falling from above V _(OVP)		11		
I _{LIMIT}	Cycle-by-cycle current limit for charge	Charge mode operation	1.8	2.4	3.0	A
V _{SHORT}	Trickle to fast charge threshold	V _(CSOUT) rising	2.0	2.1	2.2	V
	V _{SHORT} hysteresis	V _(CSOUT) falling below V _{SHORT}		100		mV
I _{SHORT}	Trickle charge charging current	V _(CSOUT) ≤ V _{SHORT}	20	30	40	mA
BOOST MODE OPERATION FOR V_{BUS} (OPA_MODE = 1, HZ_MODE = 0)						
V _{BUS_B}	Boost output voltage (to VBUS pin)	2.5 V < V _(CSOUT) < 4.5 V		5.05		V
	Boost output voltage accuracy	Including line and load regulation	–3%		3%	
I _{BO}	Maximum output current for boost	V _{BUS_B} = 5.05 V, 3.3 V < V _(CSOUT) < 4.5 V, T _J = 0°C – 125°C	350			mA
I _{BLIMIT}	Cycle by cycle current limit for boost	V _{BUS_B} = 5.05 V, 2.5 V < V _(CSOUT) < 4.5 V		1.0		A
V _{BUSOVP}	Overvoltage protection threshold for boost (VBUS pin)	Threshold over VBUS to turn off converter during boost	5.8	6.0	6.2	V
	V _{BUSOVP} hysteresis	V _{BUS} falling from above V _{BUSOVP}		162		mV
V _{BATMAX}	Maximum battery voltage for boost (CSOUT pin)	V _(CSOUT) rising edge during boost	4.75	4.9	5.05	V
	V _{BATMAX} hysteresis	V _(CSOUT) falling from above V _{BATMAX}		200		mV
V _{BATMIN}	Minimum battery voltage for boost (CSOUT pin)	During boosting		2.5		V
		Before boost starts		2.9	3.05	V
	Boost output resistance at high-impedance mode (from VBUS to PGND)	CD = 1 or HZ_MODE = 1	217			kΩ
PROTECTION						
T _{SHTDWN}	Thermal trip			165		°C
	Thermal hysteresis			10		
T _{CF}	Thermal regulation threshold	Charge current begins to reduce		120		
t _{15M}	15-minute safety timer	15-minute mode	12		15	m

7.6 Typical Performance Characteristics

Using circuit shown in Figure 28, $T_A = 25^\circ\text{C}$, unless otherwise specified.

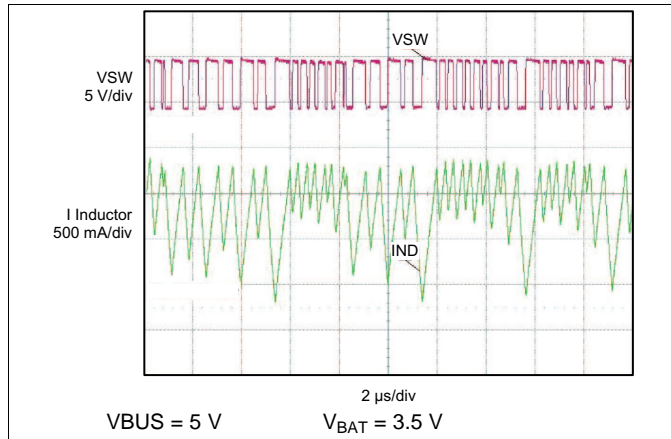

Figure 1. Cycle by Cycle Current Limiting In Charge Mode Overload Operation

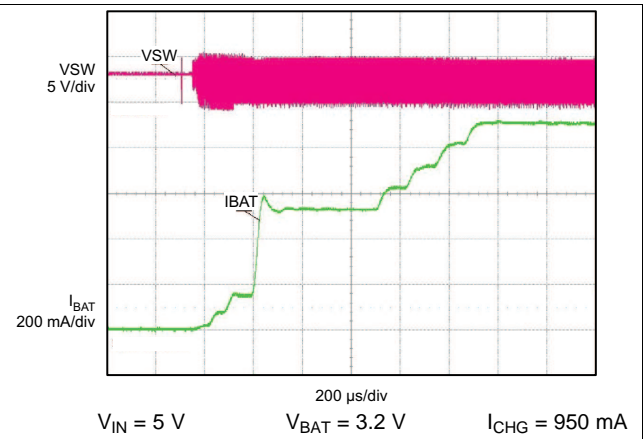

Figure 2. Charge Current Ramp Up No Input Current Limit

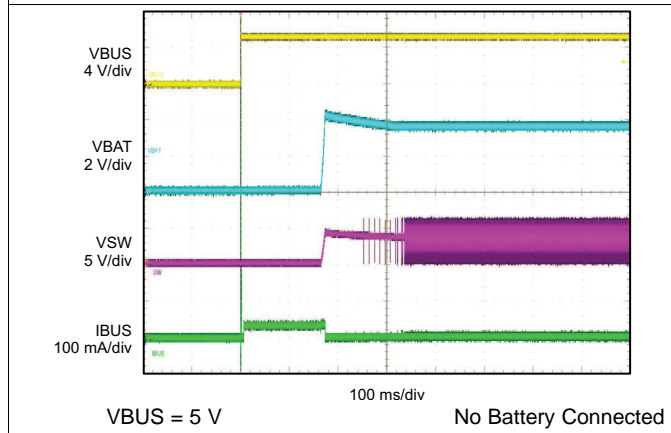

Figure 3. Battery Detection at Power Up

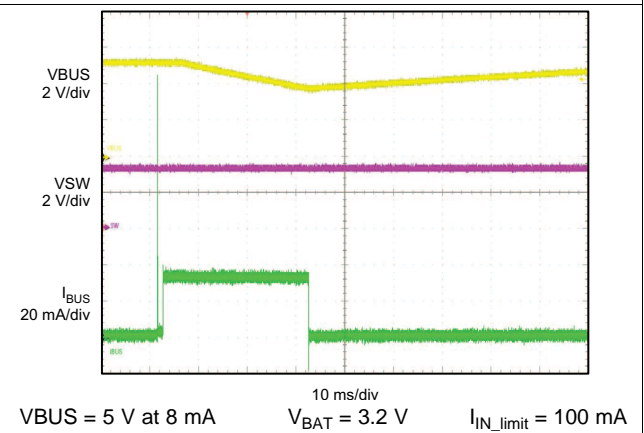

Figure 4. Poor Source Detection

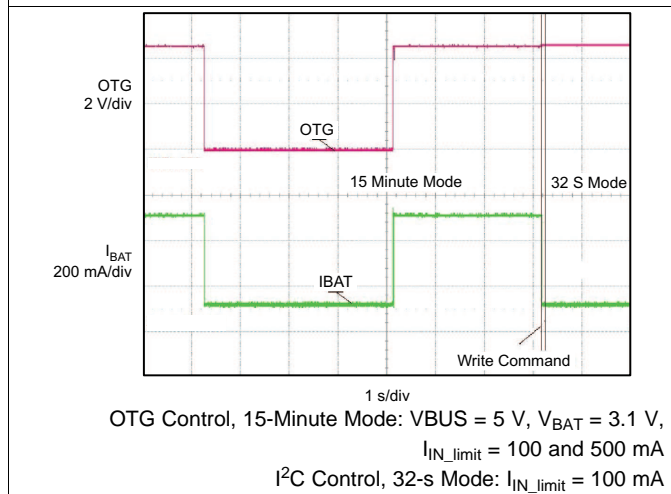

Figure 5. Input Current Control

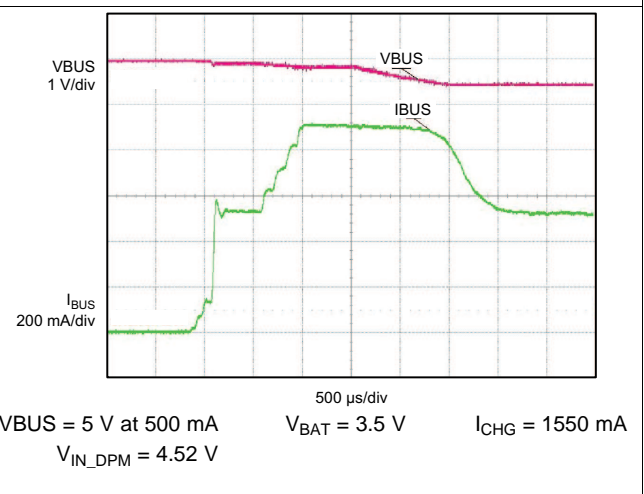

Figure 6. VIN Based DPM

Typical Performance Characteristics (continued)

Using circuit shown in Figure 28, $T_A = 25^\circ\text{C}$, unless otherwise specified.

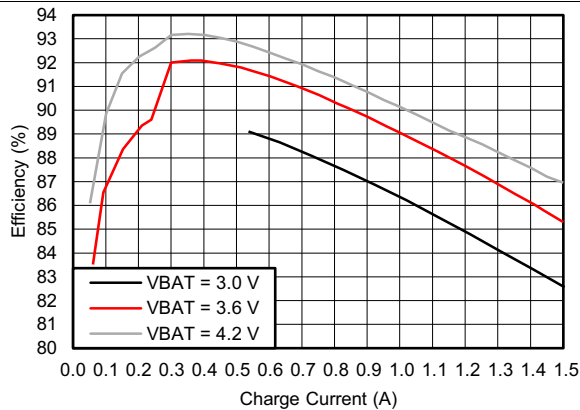

Figure 7. Charger Efficiency

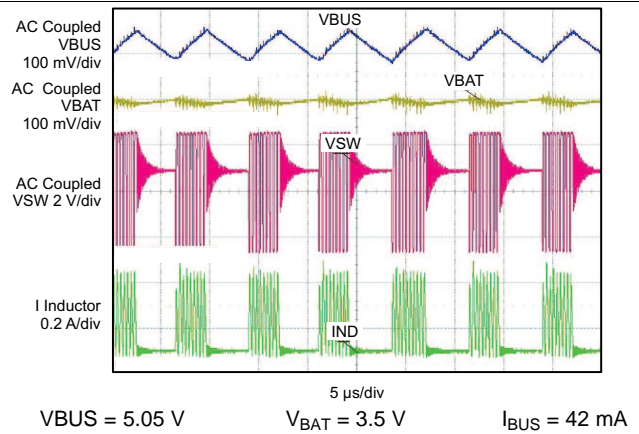

Figure 8. Boost Waveform (PFM Mode)

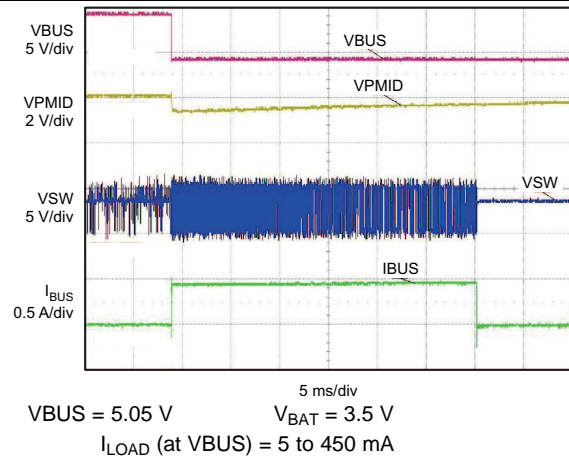

Figure 9. VBUS Overload Waveforms (Boost Mode)

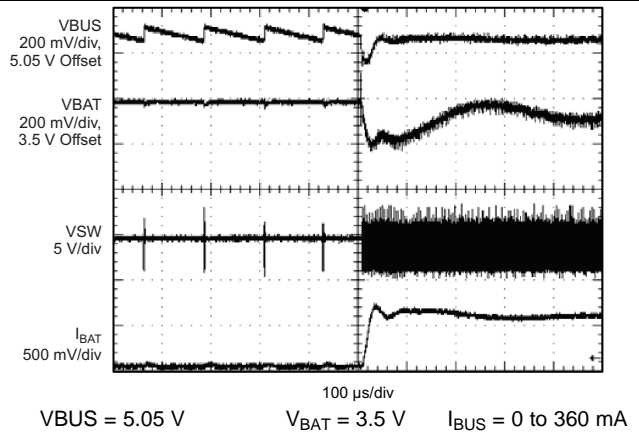

Figure 10. Load Step Up Response (Boost Mode)

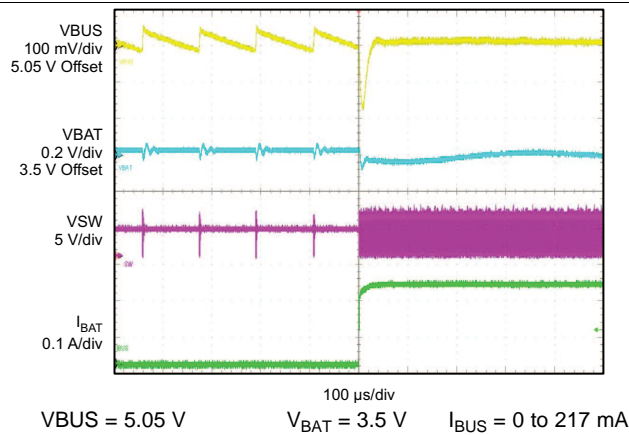

Figure 11. Load Step Up Response (Boost Mode)

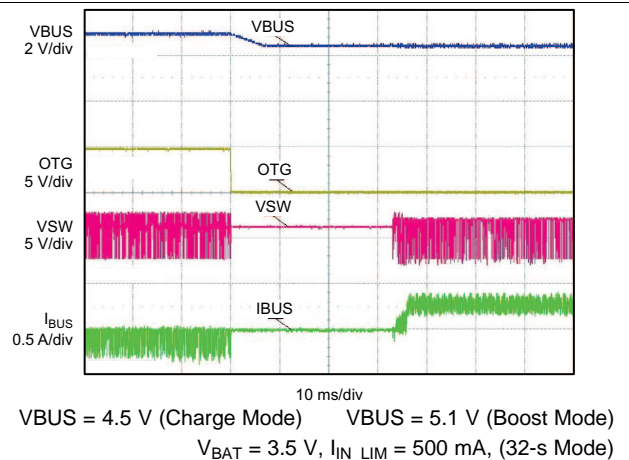

Figure 12. Boost to Charge Mode Transition (OTG Control)

Typical Performance Characteristics (continued)

Using circuit shown in Figure 28, $T_A = 25^\circ\text{C}$, unless otherwise specified.

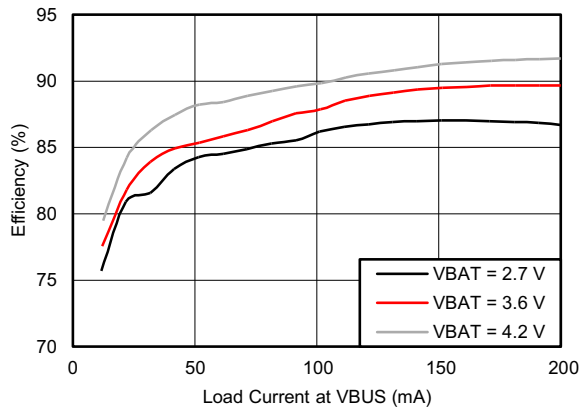

Figure 13. Boost Efficiency

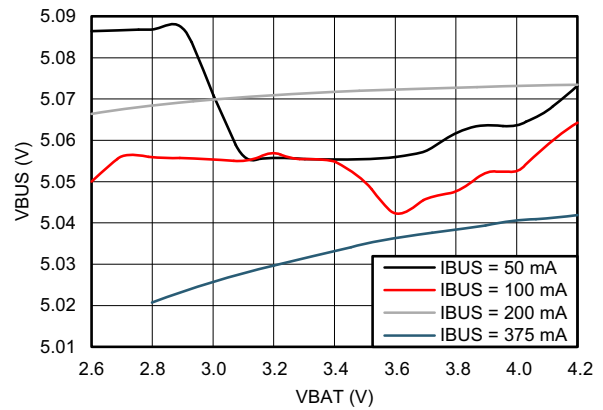

Figure 14. Line Regulation For Boost

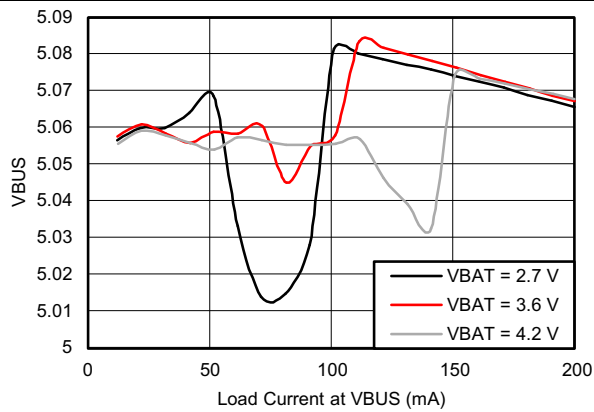

Figure 15. Load Regulation for Boost

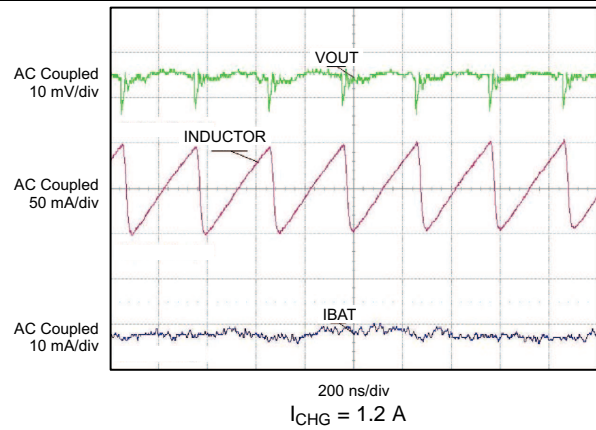

Figure 16. Output Ripple for Voltage and Current

8 Detailed Description

8.1 Overview

For a current-restricted power source, such as a USB host or hub, a high-efficiency converter is critical to fully use the input power capacity for quickly charging the battery. Due to the high efficiency for a wide range of input voltages and battery voltages, the switch mode charger is a good choice for high speed charging with less power loss and better thermal management than a linear charger.

The bq24157S includes highly integrated synchronous switch-mode chargers, featuring integrated FETs and small external components, targeted at extremely space-limited portable applications powered by 1-cell Li-Ion or Li-polymer battery pack. Furthermore, the device has bidirectional operation to achieve boost function for USB-OTG support.

The bq24157S has three operation modes: charge mode, boost mode, and high impedance mode. In charge mode, the IC supports a precision Li-ion or Li-polymer charging system for single-cell applications. In boost mode, the IC boosts the battery voltage to VBUS for powering attached OTG devices. In high impedance mode, the IC stops charging or boosting and operates in a mode with very-low current from VBUS or battery, to effectively reduce the power consumption when the portable device is in standby mode. Through I²C communication with a host (referred to as HOST or 32-second control or mode), the IC achieves smooth transition among the different operation modes. Even when no I²C communication is available, the IC starts a 15-minute safety timer and enters 15-minute (default) mode. During 15-minute operation, the charger will still charge the battery but uses each register's default values.

Table 1. Device Features

Features	bq24157S
VOVP (V)	6.5
D4 pin definition	OTG
I _{CHARGE(MAX)} at POR in 15-minute mode with R _(SNS) = 68 mΩ and OTG = High	550 mA
I _{CHARGE(MAX)} in HOST mode with R _(SNS) = 68 mΩ and safety limit register increased from default (A)	1.5
Output regulation voltage at POR (V)	3.54
Boost function	Yes
Input current limit in 15-minute mode	100 mA (OTG = Low); 500 mA (OTG = High)
Battery detection at power up	No
I ² C address	6AH
PN1 (bit4 of 03H)	1
PN0 (bit3 of 03H)	0
Safety timer and WD timer	Disabled
100-ms power-up delay	No
Spread Spectrum	Yes
Factory test mode	Yes

8.2 Functional Block Diagrams

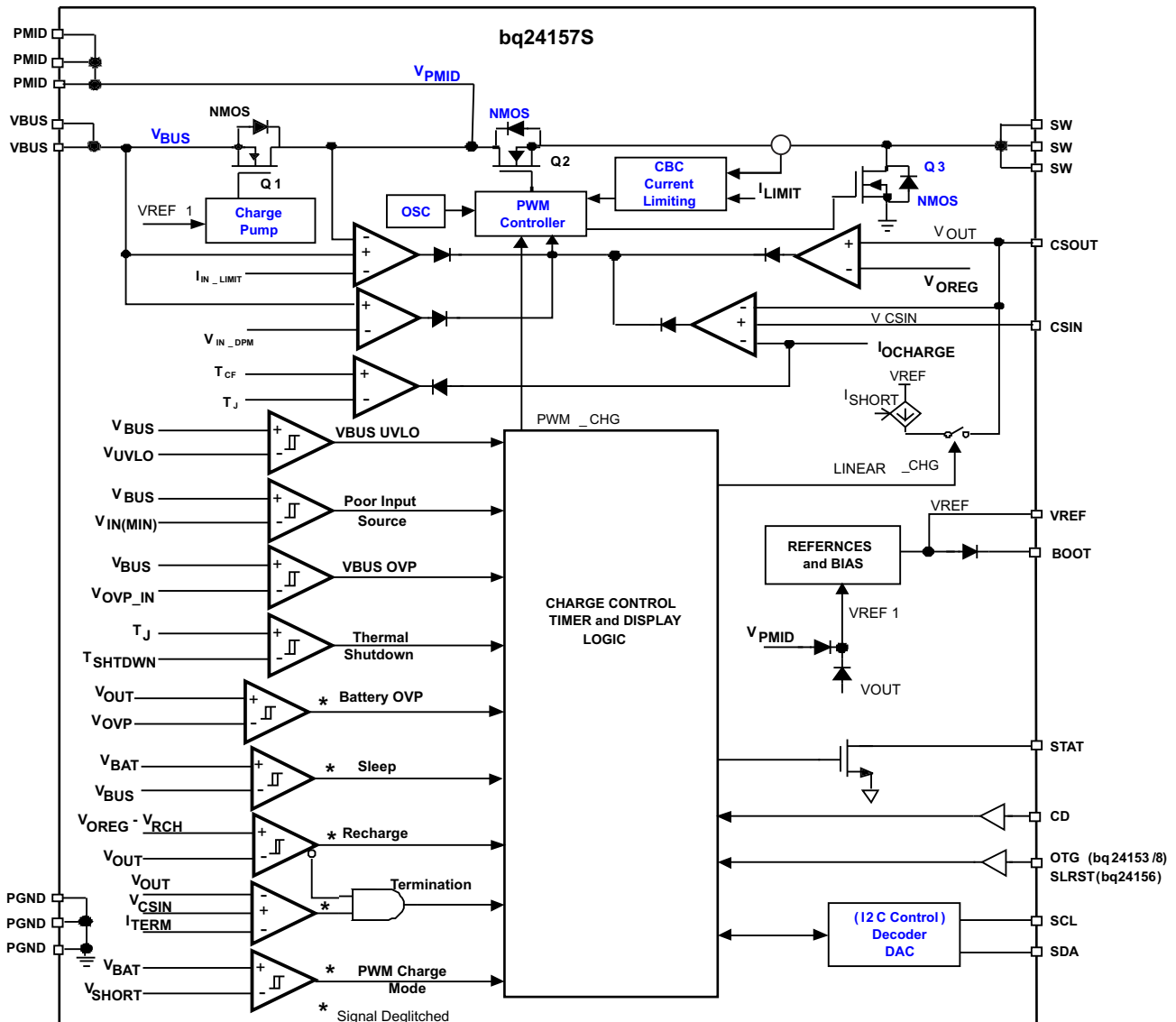

Figure 17. Function Block Diagram of bq24157S in Charge Mode

Functional Block Diagrams (continued)

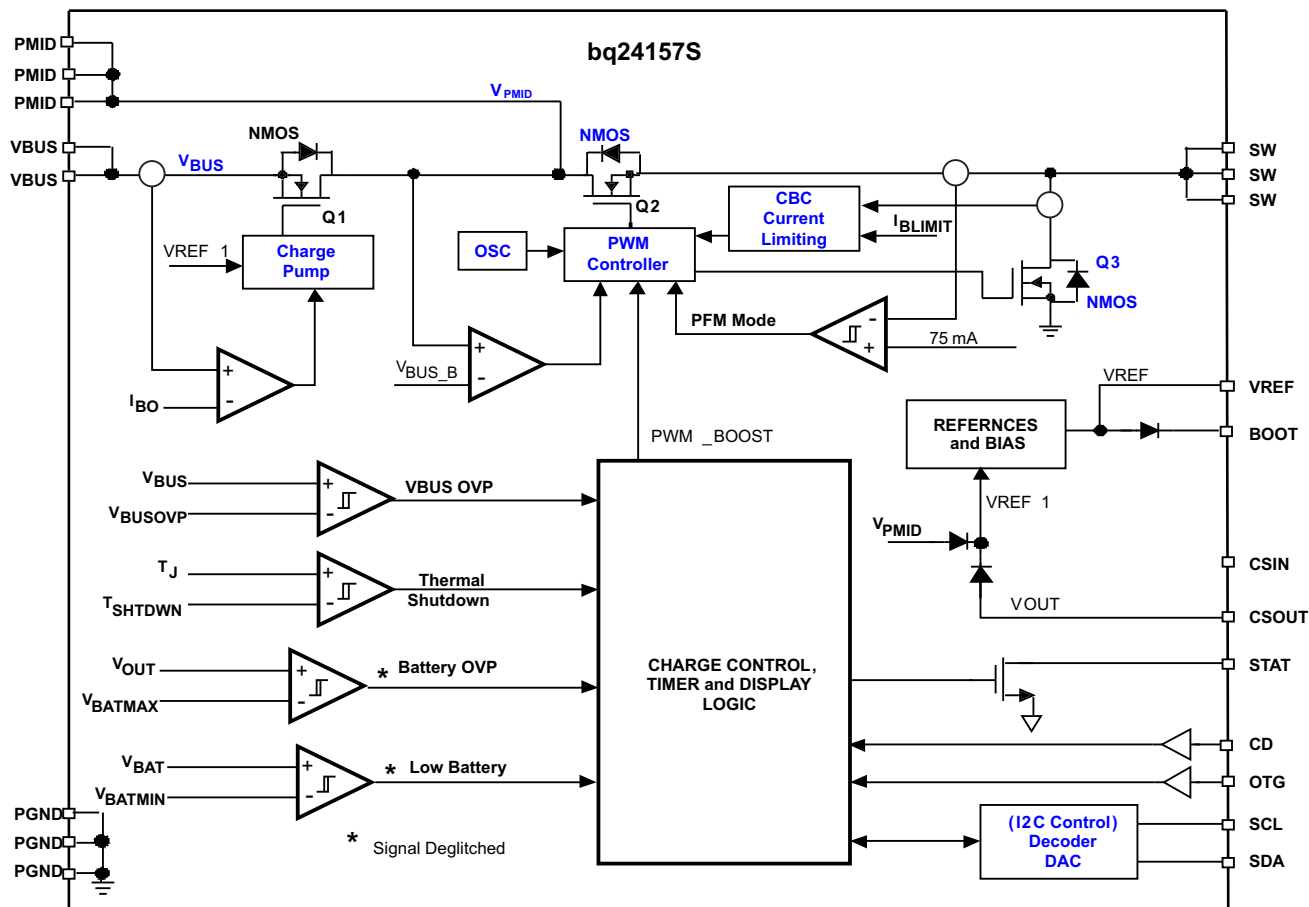

Figure 18. Function Block Diagram of bq24157S in Boost Mode

Functional Block Diagrams (continued)

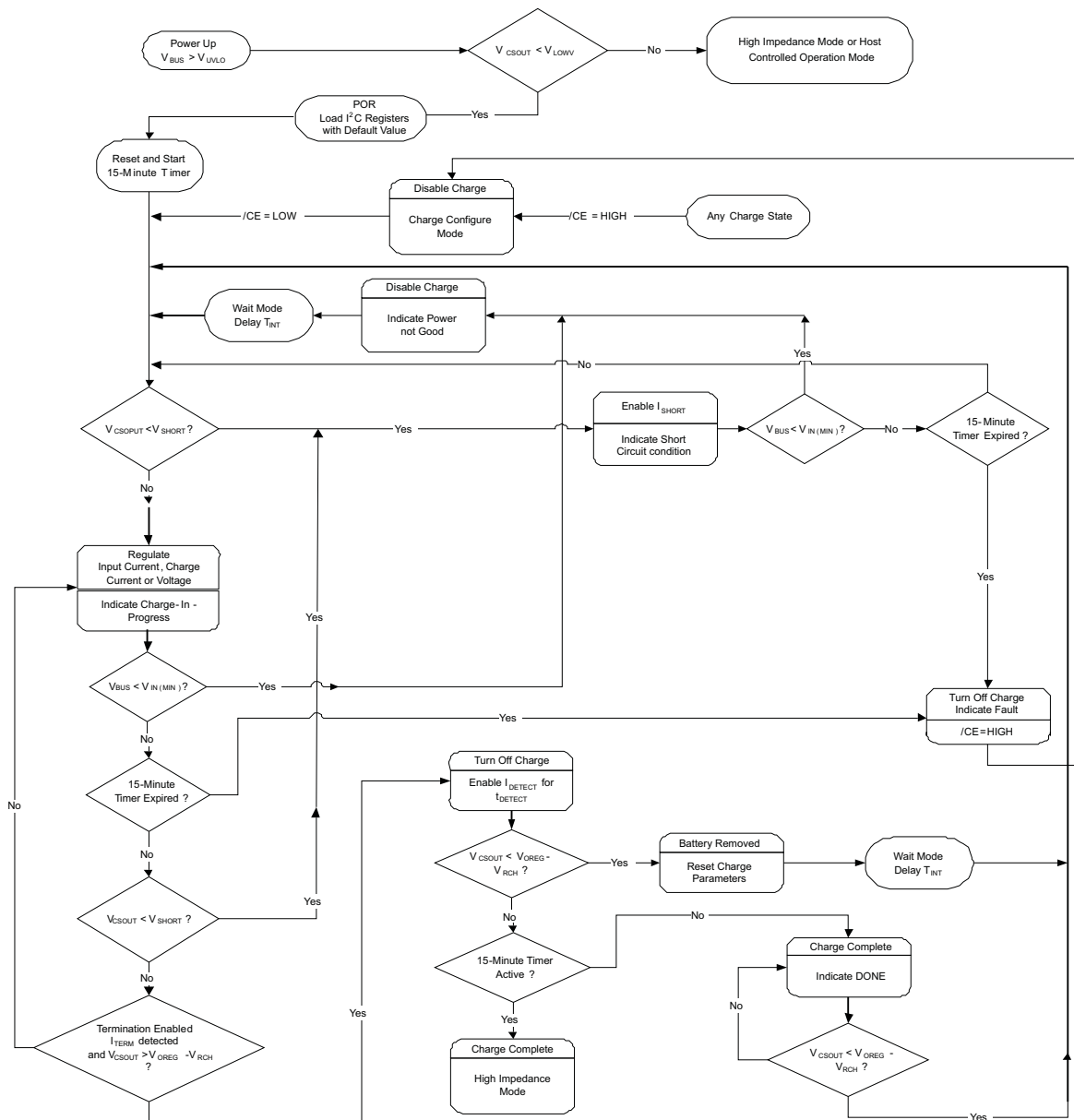

Figure 19. Operational Flow Chart of bq24157S in Charge Mode

8.3 Feature Description

8.3.1 Input Voltage Protection

8.3.1.1 Input Overvoltage Protection

The IC provides built-in input overvoltage protection to protect the device and other components against damage if the input voltage (voltage from V_{BUS} to PGND) goes too high. When an input overvoltage condition is detected, the IC turns off the PWM converter, sets fault status bits, and sends out a fault pulse from the STAT pin. Once V_{BUS} drops below the input overvoltage exit threshold, the fault is cleared and the charge process resumes.

Feature Description (continued)

8.3.1.2 Bad Adaptor Detection/Rejection

Although not shown in Figure 20, at power-on-reset (POR) of VBUS, the IC performs the bad adaptor detection by applying a current sink to VBUS. If the VBUS is higher than $V_{IN(MIN)}$ for 30 ms, the adaptor is good and the charge process begins. If the VBUS drops below $V_{IN(MIN)}$, a bad adaptor is detected. Then, the IC disables the current sink, sends a send fault pulse in FAULT pin, and sets the bad adaptor flag (B2 – B0 = 011 for register 00H). After a delay of T_{INT} , the IC repeats the adaptor detection process, as shown in Figure 20 and Figure 21.

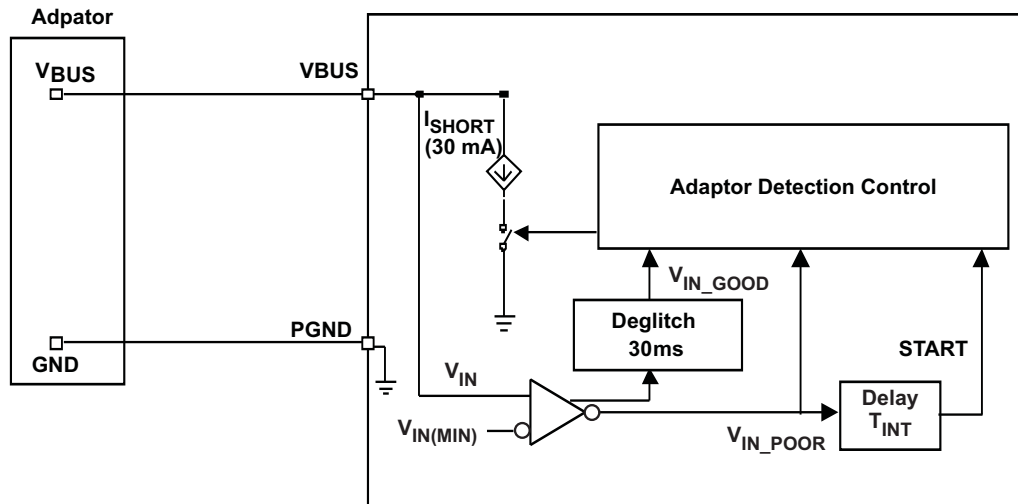
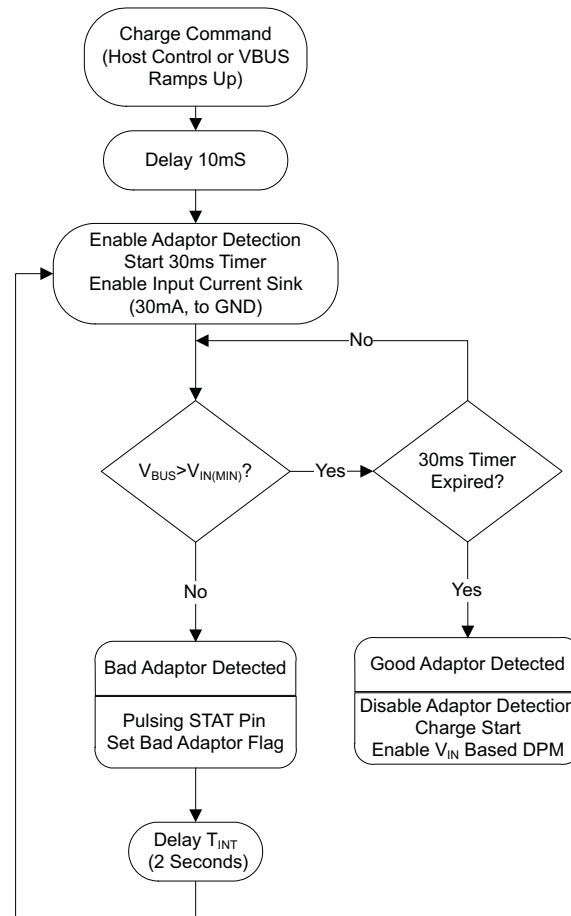

Figure 20. Bad Adaptor Detection Circuit

Feature Description (continued)

Figure 21. Bad Adaptor Detection Scheme Flow Chart
8.3.1.3 Sleep Mode

The IC enters the low-power sleep mode if the VBUS pin voltage falls below the sleep-mode entry threshold, $V_{CSOUT} + V_{SLP}$, and VBUS is higher than the bad adaptor detection threshold, $V_{IN(MIN)}$. This feature prevents draining the battery during the absence of VBUS. During sleep mode, both the reverse blocking switch Q1 and PWM are turned off.

8.3.1.4 Input Voltage Based DPM (Special Charger Voltage Threshold)

During the charging process, if the input power source is not able to support the programmed or default charging current, the VBUS voltage will decrease. After the VBUS drops to V_{IN_DPM} (default 4.52 V), the charge current begins to taper down to prevent any further drop of VBUS. When the IC enters this mode, the charge current is lower than the set value and the special charger bit is set (B4 in register 05H). This feature makes the IC compatible with adapters having different current capabilities.

8.3.2 Battery Protection
8.3.2.1 Output Overvoltage Protection

The IC provides a built-in overvoltage protection to protect the device and other components against damage if the battery voltage goes too high, as when the battery is suddenly removed. When an overvoltage condition is detected, the IC turns off the PWM converter, sets fault status bits, and sends out a fault pulse from the STAT pin. When $V_{(CSOUT)}$ drops to the battery overvoltage exit threshold, the fault is cleared and the charge process resumes.

Feature Description (continued)

8.3.2.2 Battery Short Protection

During the normal charging process, if the battery voltage is lower than the short-circuit threshold, V_{SHORT} , the charger operates in short circuit mode with a lower charge rate of I_{SHORT} .

8.3.2.3 Battery Detection in Host Mode

For applications with removable battery packs, the IC provides a battery absent detection scheme to reliably detect insertion or removal of battery packs.

During the normal charging process with host control, when the voltage at the CSOUT pin is above the battery recharge threshold, $V_{\text{OREG}} - V_{\text{RCH}}$, and the termination charge current is detected, the IC turns off the PWM charge and enables a discharge current, I_{DETECT} , for a period of t_{DETECT} , (262-ms typical), then checks the battery voltage. If the battery voltage is still above the recharge threshold after t_{DETECT} , the battery is present. On the other hand, if the battery voltage is below the battery recharge threshold, the battery is absent. Under this condition, the charge parameters (such as input current limit) are reset to the default values and charge resumes after a delay of t_{INT} . This function ensures that the charge parameters are reset whenever the battery is replaced.

8.3.3 15-Minute Safety Timer

The bq24157S stays in 15-minute (default) mode indefinitely until I²C communication begins. When I²C communication begins, the host processor does not need to reset this safety timer while charging the battery.

8.3.4 USB Friendly Power Up

Prior to POR, if the host continues to write the TMR_RST bit to 1, to stay in 32-second mode, then at POR, the charger enters normal charge mode (using the desired control bits). If not in 32-second mode at POR, the charge will operate with default bit values, until the host updates the control registers.

The default control bits set the charging current and regulation voltage low as a safety feature to avoid violating USB specifications and overcharging any of the Li-Ion chemistries, while the host has lost communication. The input current limiting is described in the following sections.

8.3.5 Input Current Limiting at Power Up

The input current sensing circuit and control loop are integrated into the IC. When operating in 15-minute mode, the OTG pin logic level sets the input current limit to 100 mA for a logic low and 500 mA for a logic high. In 32-second mode, the input current limit is set by the programmed control bits in register 01H.

8.3.6 Factory Mode

The factory mode can be enabled only when the battery is removed. This can be done through an I²C register 05 bit 6 (see [Table 9](#)). The purpose of the mode is to operate the phone in a GSM phone call with no-battery connected and do a calibration of the system. Setting the factory mode bit enables the following changes:

- 20X ICHG amp is disabled – that is, output current limit is disabled
- Cycle-by-cycle HS current limit threshold is doubled (current typical is 2.4 A, shifts to 4.8 A)
- CCM mode is always enabled (because the current could go from 0 to full GSM pulse)

8.3.7 Spread Spectrum Mode

The purpose of the spread spectrum clock modulation is to reduce EMI. In the spread spectrum mode, the switching frequency is not fixed to 3 MHz. It is instead shifted by $\pm 10\%$ from the fixed 3-MHz switching frequency. The shift is happening in eight steps, four steps in the upper range and four steps in the lower range every 170 μs . By modulating the clock frequency, the energy of the switching converter's EMI is distributed over a wider range of frequencies thereby lowering the magnitude of EMI at 3 MHz $\pm 10\%$ as well as harmonic frequencies.

Feature Description (continued)

8.3.8 PWM Controller in Charge Mode

The IC provides an integrated, fixed 3-MHz frequency voltage-mode controller to regulate charge current or voltage. This type of controller is used to improve line transient response, thereby, simplifying the compensation network used for both continuous and discontinuous current conduction operation. The voltage and current loops are internally compensated using a Type-III compensation scheme that provides enough phase margin for stable operation, allowing the use of small ceramic capacitors with a low ESR. The device operates between 0% to 99.5% duty cycles.

The IC has back-to-back common-drain N-channel FETs at the high side and one N-channel FET at the low side. The input N-FET (Q1) prevents battery discharge when VBUS is lower than V_{CSOUT} . The second high-side N-FET (Q2) is the switching control switch. A charge pump circuit is used to provide gate drive for Q1, while a bootstrap circuit with an external bootstrap capacitor is used to supply the gate drive voltage for Q2.

Cycle-by-cycle current limit is sensed through the FETs Q2 and Q3. The threshold for Q2 is set to a nominal 2.4-A peak current. The low-side FET (Q3) also has a current limit that decides if the PWM controller will operate in synchronous or non-synchronous mode. This threshold is set to 100 mA and it turns off the low-side N-channel FET (Q3) before the current reverses, preventing the battery from discharging. Synchronous operation is used when the current of the low-side FET is greater than 100 mA to minimize power losses.

8.3.9 Battery Charging Process

At the beginning of precharge, while battery voltage is below the $V_{(SHORT)}$ threshold, the IC applies a short-circuit current, $I_{(SHORT)}$, to the battery. When the battery voltage is above V_{SHORT} and below V_{OREG} , the charge current ramps up to fast charge current, $I_{OCHARGE}$, or a charge current that corresponds to the input current of I_{IN_LIMIT} . The slew rate for fast charge current is controlled to minimize the current and voltage overshoot during transient. Both the input current limit, I_{IN_LIMIT} , and fast charge current, $I_{OCHARGE}$, can be set by the host. When the battery voltage reaches the regulation voltage, V_{OREG} , the charge current is tapered down, as shown in [Figure 27](#). The voltage regulation feedback occurs by monitoring the battery-pack voltage between the CSOUT and PGND pins. In HOST mode, the regulation voltage is adjustable (3.5 to 4.44 V) and is programmed through I²C interface. In 15-minute mode, the regulation voltage is fixed at 3.54 V.

The IC monitors the charging current during the voltage regulation phase. If termination is enabled, during the normal charging process with HOST control, after the voltage at the CSOUT pin is above the battery recharge threshold, $V_{OREG} - V_{RCH}$ for the 32-ms (typical) deglitch period, and the termination charge current I_{TERM} is detected, the IC turns off the PWM charge and enables a discharge current, I_{DETECT} , for a period of t_{DETECT} (262-ms typical), then checks the battery voltage. If the battery voltage is still above the recharge threshold after t_{DETECT} , the battery charging is complete. The battery detection routine is used to ensure termination did not occur because the battery was removed. After 40 ms (typical) for synchronization purposes of the EOC state and the counter, the status bit and pin are updated to indicate charging has completed. The termination current level is programmable. To disable the charge current termination, the host can set the charge termination bit (TE) of charge control register to 0, refer to [I²C Update Sequence](#) for details.

A new charge cycle is initiated when one of the following conditions is detected:

- The battery voltage falls below the $V_{(OREG)} - V_{(RCH)}$ threshold.
- VBUS POR, if battery voltage is below the $V_{(LOWV)}$ threshold.
- \overline{CE} bit toggle or RESET bit is set (host controlled)

8.3.10 Thermal Regulation and Protection

To prevent overheating of the chip during the charging process, the IC monitors the junction temperature, T_J , of the die and begins to taper down the charge current after T_J reaches the thermal regulation threshold, T_{CF} . The charge current is reduced to 0 when the junction temperature increases approximately 10°C above T_{CF} . In any state, if T_J exceeds T_{SHTDWN} , the IC suspends charging. In thermal shutdown mode, PWM is turned off and all timers are frozen. Charging resumes when T_J falls below T_{SHTDWN} by approximately 10°C.

Feature Description (continued)

8.3.11 Charge Status Output, STAT Pin

The STAT pin is used to indicate operation conditions. STAT is pulled low during charging when EN_STAT bit in control register (00H) is set to 1. Under other conditions, STAT pin behaves as a high impedance (open-drain) output. Under fault conditions, a 128- μ s pulse will be sent out to notify the host. The status of STAT pin at different operation conditions is summarized in [Table 2](#). The STAT pin can be used to drive an LED or communicate to the host processor.

Table 2. STAT Pin Summary

Charge State	Stat
Charge in progress and EN_STAT = 1	Low
Other normal conditions	Open-drain
Charge mode faults: Timer fault, sleep mode, VBUS or battery overvoltage, poor input source, VBUS UVLO, no battery, thermal shutdown	128- μ s pulse, then open-drain
Boost mode faults: Timer fault, over load, VBUS or battery overvoltage, low battery voltage, thermal shutdown	128- μ s pulse, then open-drain

8.3.12 Control Bits in Charge Mode

8.3.12.1 \overline{CE} Bit (Charge Mode)

The \overline{CE} bit in the control register is used to disable or enable the charge process. A low logic level (0) on this bit enables the charge and a high logic level (1) disables the charge.

8.3.12.2 RESET Bit

The RESET bit in the Battery Termination/Fast Charge Current register is used to reset all the charge parameters. Writing 1 to the RESET bit will reset all the charge parameters to default values except the safety limit register, and RESET bit is automatically cleared to 0 when the charge parameters are reset. It is designed for charge parameter reset before charge starts and TI does not recommended to set the RESET bit while charging or boosting are in progress.

8.3.12.3 OPA_MODE Bit

OPA_MODE is the operation mode control bit. When OPA_MODE = 0, the IC operates as a charger; if HZ_MODE is set to 0, refer to [Table 3](#) for details. When OPA_MODE = 1 and HZ_MODE = 0, the IC operates in boost mode.

Table 3. Operation Mode Summary

OPA_MODE	HZ_MODE	Operation Mode
0	0	Charge (no fault) Charge configure (fault, $V_{bus} > UVLO$) High impedance ($V_{bus} < UVLO$)
1	0	Boost (no faults) Any fault go to charge configure mode
X	1	High impedance

8.3.13 Control Pins in Charge Mode

8.3.13.1 CD Pin (Charge Disable)

The CD pin is used to disable the charging process. When the CD pin is low, charge is enabled. When the CD pin is high, charge is disabled and the charger enters high impedance (Hi-Z) mode. In 15-minute mode, taking the CD pin high resets the 15-minute timer; while in 32-s mode, taking the CD pin high does not reset the 32-s timer.

8.3.14 Boost Mode Operation

In 32-s mode, when OTG pin is high (and OTG_EN bit is high thereby enabling OTG functionality) or the operation mode bit (OPA_MODE) is set to 1, the device operates in boost mode and delivers the power to VBUS from the battery. In normal boost mode, the device converts the battery voltage to V_{BUS-B} (about 5.05 V) and delivers a current as much as I_{BO} (about 375 mA for bq24157S) to support other USB OTG devices connected to the USB connector.

8.3.14.1 PWM Controller in Boost Mode

Similar to charge mode operation, in boost mode, the IC provides an integrated, fixed 3-MHz frequency voltage-mode controller to regulate output voltage at PMID pin (V_{PMID}). The voltage control loop is internally compensated using a Type-III compensation scheme that provides enough phase margin for stable operation with a wide load range and battery voltage range.

In boost mode, the input N-FET (Q1) prevents battery discharge when VBUS pin is over loaded. Cycle-by-cycle current limit is sensed through the internal sense FET for Q3. The cycle-by-cycle current limit threshold for Q3 is set to a nominal 1.0-A peak current. Synchronous operation is used in PWM mode to minimize power losses.

8.3.14.2 Boost Start Up

To prevent the inductor saturation and limit the inrush current, a soft-start control is applied during the boost start up.

8.3.14.3 PFM Mode at Light Load

In boost mode, under light load conditions, the IC operates in pulse skipping mode (PFM mode) to reduce the power loss and improve the converter efficiency. During boosting, the PWM converter is turned off when the inductor current is less than 75 mA, and the PWM is turned back on only when the voltage at PMID pin drops to about 99.5% of the rated output voltage. A unique pre-set circuit is used to make the smooth transition between PWM and PFM mode.

8.3.14.4 Protection in Boost Mode

8.3.14.4.1 Output Overvoltage Protection

The IC provides built-in overvoltage protection to protect the device and other components against damage if the VBUS voltage goes too high. When an overvoltage condition is detected, the IC turns off the PWM converter, resets OPA_MODE bit to 0, sets fault status bits, and sends out a fault pulse from the STAT pin. When VBUS drops to the normal level, the boost starts after host sets OPA_MODE to 1 or OTG pin stays in active status.

8.3.14.4.2 Output Overload Protection

The IC provides built-in overload protection to prevent the device and battery from damage when VBUS is overloaded. After the overload condition is detected, Q1 operates in linear mode to limit the output current. If the overload condition lasts for more than 30 ms, the overload fault is detected. When an overload condition is detected, the IC turns off the PWM converter, resets OPA_MODE bit to 0, sets fault status bits, and sends out fault pulse in STAT pin. The boost will not start until the host clears the fault register.

8.3.14.4.3 Battery Overvoltage Protection

During boosting, when the battery voltage is above the battery overvoltage threshold, V_{BATMAX} , or below the minimum battery voltage threshold, V_{BATMIN} , the IC turns off the PWM converter, resets OPA_MODE bit to 0, sets fault status bits, and sends out fault pulse in STAT pin. After the battery voltage goes above V_{BATMIN} , the boost will start after the host sets OPA_MODE to 1 or OTG pin stays in active status.

8.3.14.5 STAT Pin in Boost Mode

During normal boosting operation, the STAT pin behaves as a high impedance (open-drain) output. Under fault conditions, a 128- μ s pulse is sent out to notify the host.

8.3.15 High Impedance (Hi-Z) Mode

In Hi-Z mode, the charger stops charging and enters a low quiescent current state to conserve power. Taking the CD pin high causes the charger to enter Hi-Z mode. When in 15-minute mode and the CD pin is low, the charger automatically enters Hi-Z mode if either:

- $V_{BUS} > UVLO$ and a battery with $V_{BAT} > V_{LOWV}$ is inserted, or
- V_{BUS} falls below $UVLO$.

When in HOST mode and the CD is low, the charger can be placed into Hi-Z mode if the HZ-MODE control bit is set to 1 and OTG pin is not in active status.

To exit Hi-Z mode, the CD pin must be low, V_{BUS} must be higher than $UVLO$, and the HOST must write a 0 to the HZ-MODE control bit.

8.3.16 Serial Interface Description

I²C is a 2-wire serial interface developed by Philips Semiconductor (see I²C-Bus Specification, Version 2.1, January 2000). The bus consists of a data line (SDA) and a clock line (SCL) with pullup structures. When the bus is idle, both SDA and SCL lines are pulled high. All the I²C compatible devices connect to the I²C bus through open drain I/O pins, SDA and SCL. A master device, usually a microcontroller or a digital signal processor, controls the bus. The master is responsible for generating the SCL signal and device addresses. The master also generates specific conditions that indicate the START and STOP of data transfer. A slave device receives and/or transmits data on the bus under control of the master device.

The IC works as a slave and is compatible with the following data transfer modes, as defined in the I²C-Bus Specification: standard mode (100 kbps), fast mode (400 kbps), and high-speed mode (up to 3.4 Mbps in write mode). The interface adds flexibility to the battery charge solution, enabling most functions to be programmed to new values depending on the instantaneous application requirements. Register contents remain intact as long as supply voltage remains above 2.2 V (typical). I²C is asynchronous, which means that it runs off of SCL. The device has no noise or glitch filtering on SCL, so SCL input needs to be clean. Therefore, TI recommends that SDA changes while SCL is low.

The data transfer protocol for standard and fast modes is the same; therefore, they are referred to as F/S-mode in this document. The protocol for high-speed mode is different from the F/S-mode, and it is referred to as HS-mode. The bq24157S device supports 7-bit addressing only. The device 7-bit address is defined as 1101010 (6AH).

8.3.16.1 F/S Mode Protocol

The master initiates data transfer by generating a start condition. The start condition is when a high-to-low transition occurs on the SDA line while SCL is high, as shown in Figure 22. All I²C-compatible devices should recognize a start condition.

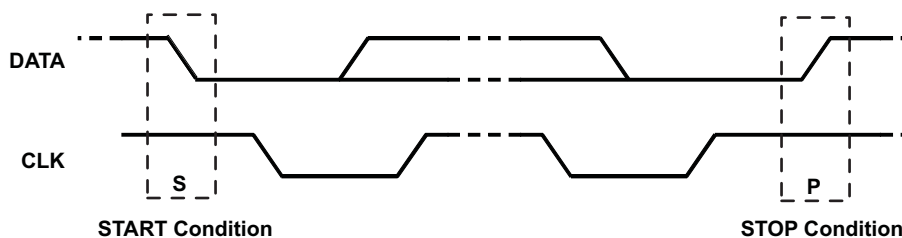
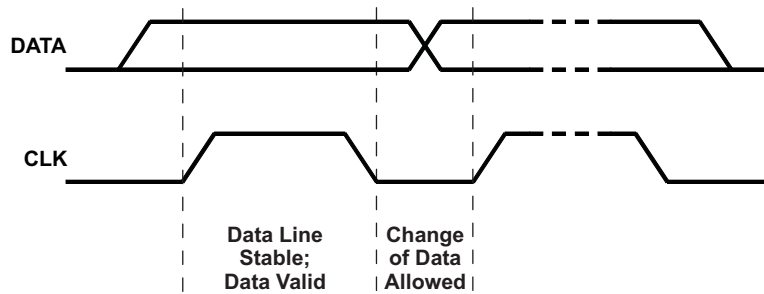
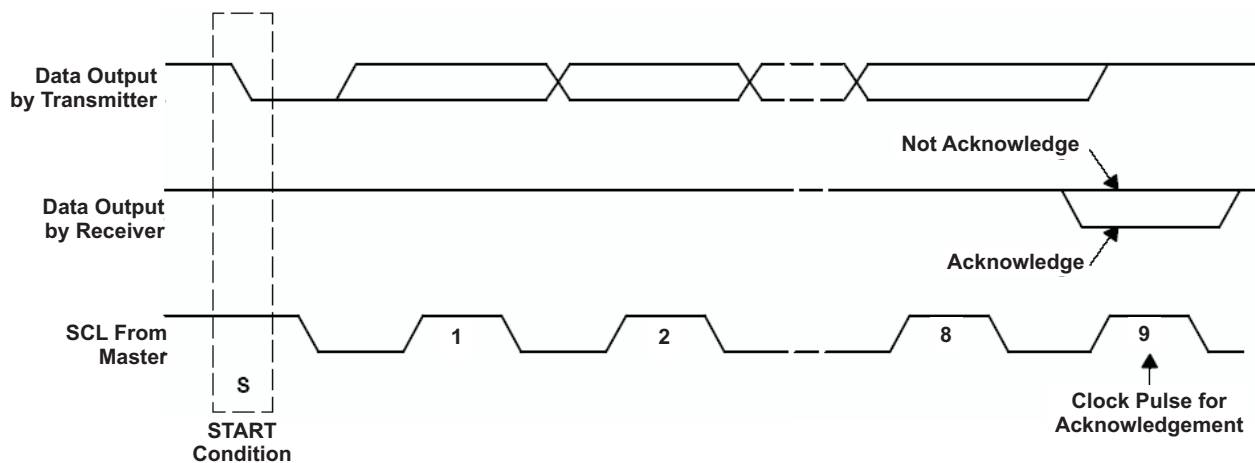

Figure 22. Start and Stop Condition

The master then generates the SCL pulses, and transmits the 8-bit address and the Read or Write direction bit R/W on the SDA line. During all transmissions, the master ensures that data is valid. A valid data condition requires the SDA line to be stable during the entire high period of the clock pulse (see Figure 23). All devices recognize the address sent by the master and compare it to their internal fixed addresses. Only the slave device with a matching address generates an acknowledge (see Figure 23) by pulling the SDA line low during the entire high period of the ninth SCL cycle. Upon detecting this acknowledge, the master knows that communication link with a slave has been established.

Figure 23. Bit Transfer on the Serial Interface

The master generates further SCL cycles to either transmit data to the slave (R/W bit 1) or receive data from the slave (R/W bit 0). In either case, the receiver needs to acknowledge the data sent by the transmitter. So an acknowledge signal can either be generated by the master or by the slave, depending on which one is the receiver. The 9-bit valid data sequences consisting of 8-bit data and 1-bit acknowledge can continue as long as necessary. To signal the end of the data transfer, the master generates a STOP condition by pulling the SDA line from low to high while the SCL line is high (see [Figure 25](#)). This releases the bus and stops the communication link with the addressed slave. All I²C compatible devices must recognize the stop condition. Upon the receipt of a stop condition, all devices know that the bus is released, and they wait for a start condition followed by a matching address. If a transaction is terminated prematurely, the master needs to send a STOP condition to prevent the slave I²C logic from getting stuck in a bad state. Attempting to read data from register addresses not listed in this section will result in FFh being read out.

Figure 24. Acknowledge on the I²C Bus

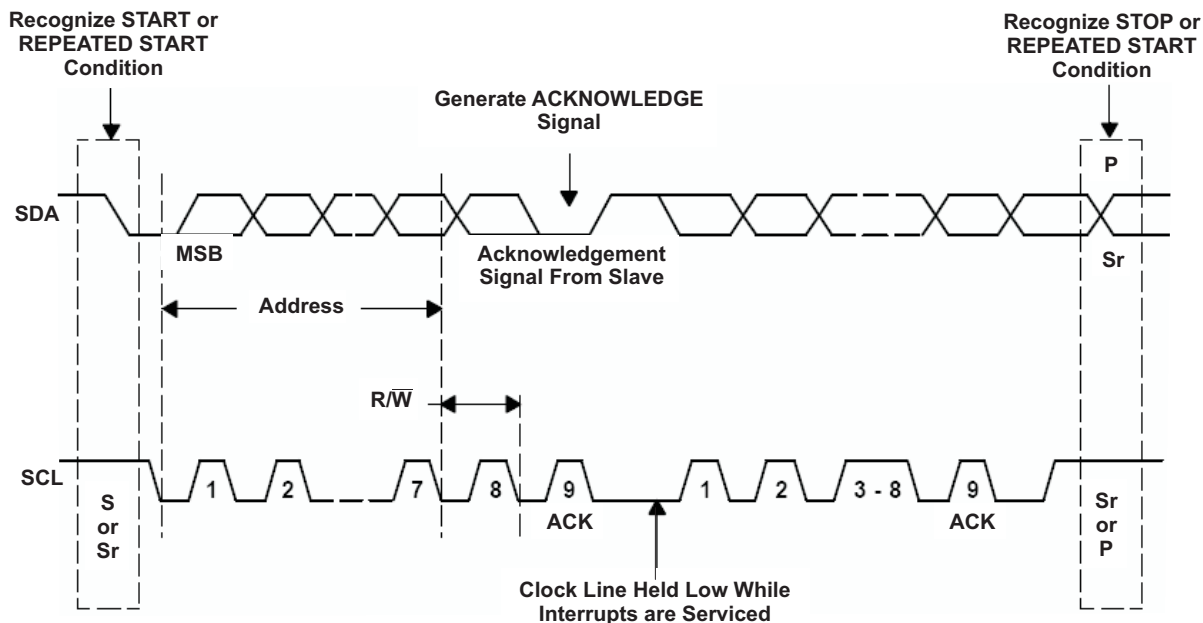

Figure 25. Bus Protocol

8.3.16.2 HS Mode Protocol

When the bus is idle, both SDA and SCL lines are pulled high by the pullup devices.

The master generates a START condition followed by a valid serial byte containing HS master code 00001XXX. This transmission is made in F/S-mode at no more than 400 Kbps. No device is allowed to acknowledge the HS master code, but all devices must recognize it and switch their internal setting to support 3.4-Mbps operation.

The master then generates a repeated START condition (a repeated START condition has the same timing as the start condition). After this repeated START condition, the protocol is the same as F/S-mode, except that transmission speeds up to 3.4 Mbps are allowed. A STOP condition ends the HS-mode and switches all the internal settings of the slave devices to support the F/S-mode. Instead of using a STOP condition, repeated START conditions should be used to secure the bus in HS-mode. If a transaction is terminated prematurely, the master needs to send a STOP condition to prevent the slave I²C logic from getting stuck in a bad state.

Attempting to read data from register addresses not listed in this section results in FFh being read out.

8.3.16.3 I²C Update Sequence

The IC requires a start condition, a valid I²C address, a register address byte, and a data byte for a single update. After the receipt of each byte, the IC acknowledges by pulling the SDA line low during the high period of a single clock pulse. A valid I²C address selects the IC. The IC performs an update on the falling edge of the acknowledge signal that follows the LSB byte.

For the first update, the IC requires a START condition, a valid I²C address, a register address byte, and a data byte. For all consecutive updates, the IC needs a register address byte and a data byte. When a STOP condition is received, the IC releases the I²C bus and awaits new start conditions.

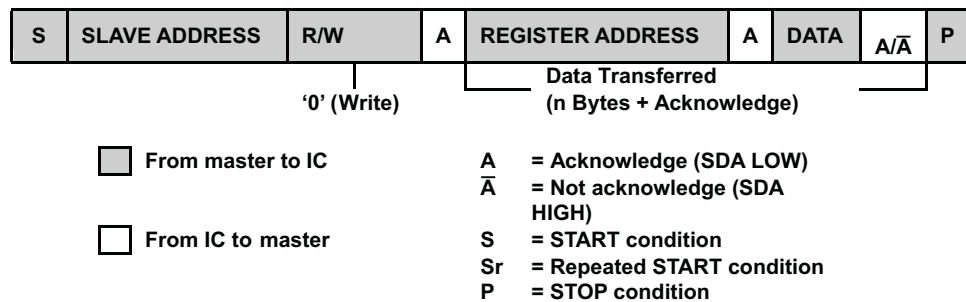
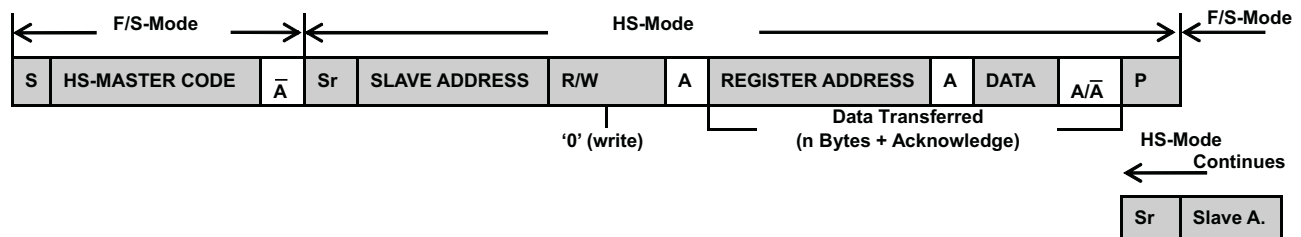
(a) F/S-Mode

(b) HS-Mode
Figure 26. Data Transfer Format In F/S Mode And HS Mode

8.3.16.4 Slave Address Byte

The slave address byte is the first byte received following the START condition from the master device.

MSB							LSB
X	1	1	0	1	0	1	1

8.3.16.5 Register Address Byte

Following the successful acknowledgment of the slave address, the bus master will send a byte to the IC, which contains the address of the register to be accessed. The IC contains five 8-bit registers accessible through a bidirectional I²C-bus interface. Among them, four internal registers have read and write access; and one has only read access.

MSB						LSB	
0	0	0	0	0	D2	D1	D0

8.4 Device Functional Modes

8.4.1 Charge Mode Operation

8.4.1.1 Charge Profile

When a good battery with voltage below the recharge threshold has been inserted and a good adapter is attached, the bq24157S enters charge mode. In charge mode, the IC has five control loops to regulate input voltage, input current, charge current, charge voltage, and device junction temperature. During the charging process, all five loops are enabled and the one that is dominant takes control. The IC supports a precision Li-ion or Li-polymer charging system for single-cell applications. [Figure 27 \(a\)](#) indicates a typical charge profile without input current regulation loop. It is the traditional CC/CV charge curve, while [Figure 27 \(b\)](#) shows a typical charge profile when input current limiting loop is dominant during the constant current mode. In this case, the charge current is higher than the input current, so the charge process is faster than the linear chargers. The input voltage threshold for DPM loop, input current limits, charge current, termination current, and charge voltage are all programmable using I²C interface.

Device Functional Modes (continued)

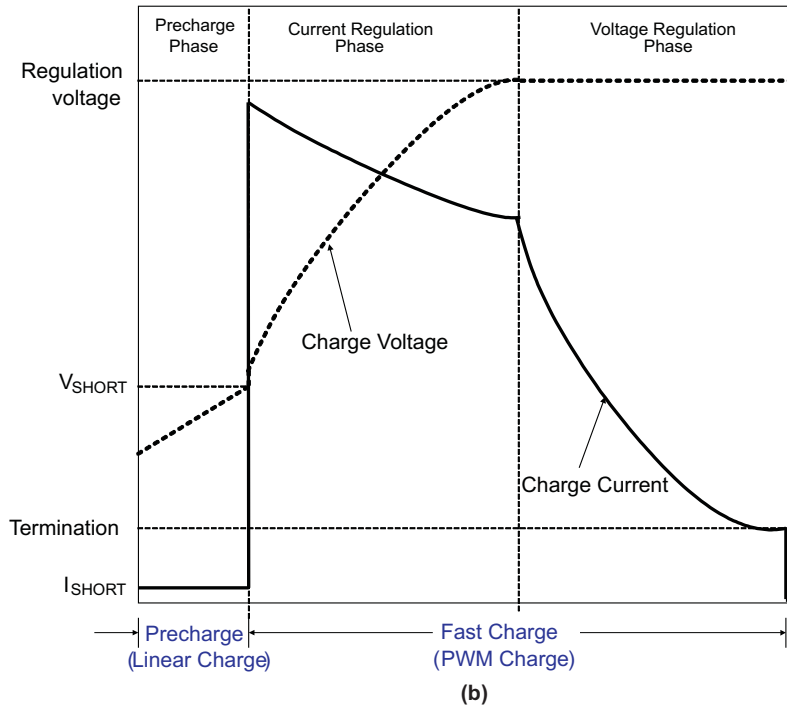
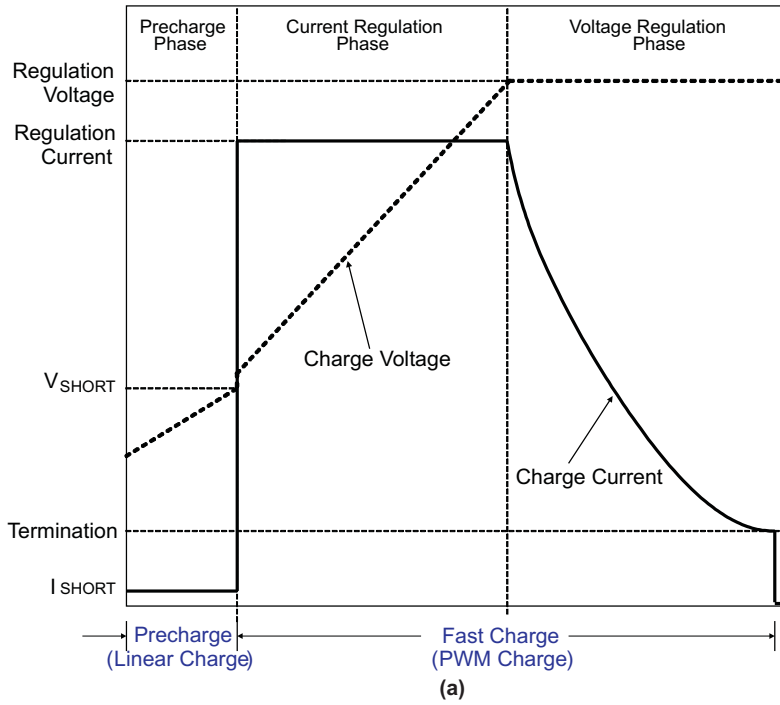

Figure 27. Typical Charging Profile:
 (a) Without Input Current Limit
 (b) With Input Current Limit

8.5 Register Maps

Table 4. Status/Control Register (Read or Write)
Memory Location: 00, Reset State: x1xx 0xxx

BIT	NAME	Read or Write	FUNCTION
B7 (MSB)	TMR_RST/OTG	Read or Write	Write: TMR_RST function, write 1 to reset the safety timer (auto clear) Read: OTG pin status 0 – OTG pin at low level 1 – OTG pin at high level
B6	EN_STAT	Read or Write	0 – Disable STAT pin function 1 – Enable STAT pin function (default 1)
B5	STAT2	Read only	00 – Ready 01 – Charge in progress
B4	STAT1	Read only	10 – Charge done 11 – Fault
B3	BOOST	Read only	1 – Boost mode, 0 – Not in boost mode
B2	FAULT_3	Read only	Charge mode: 000 – Normal 001 – VBUS OVP 010 – Sleep mode 011 – Bad Adaptor or $V_{BUS} < V_{UVLO}$ 100 – Output OVP 101 – Thermal shutdown 110 – Timer fault 111 – No battery
B1	FAULT_2	Read only	
B0 (LSB)	FAULT_1	Read only	Boost mode: 000 – Normal 001 – VBUS OVP 010 – Overload 011 – Battery voltage is too low 100 – Battery OVP 101 – Thermal shutdown 110 – Timer fault 111 – N/A

Table 5. Control Register (Read or Write)
Memory Location: 01, Reset State: 0011 0000

BIT	NAME	Read or Write	FUNCTION
B7 (MSB)	lin_Limit_2	Read or Write	00 – USB host with 100-mA current limit 01 – USB host with 500-mA current limit 10 – USB host/charger with 800-mA current limit 11 – No input current limit
B6	lin_Limit_1	Read or Write	
B5	$V_{(LOWV_2)}$ ⁽¹⁾	Read or Write	Weak battery voltage threshold: 200-mV step (default 1)
B4	$V_{(LOWV_1)}$ ⁽¹⁾	Read or Write	Weak battery voltage threshold: 100-mV step (default 1)
B3	TE	Read or Write	1 – Enable charge current termination 0 – Disable charge current termination (default 0)
B2	\overline{CE}	Read or Write	1 – Charger is disabled 0 – Charger enabled (default 0)
B1	HZ_MODE	Read or Write	1 – High impedance mode 0 – Not high impedance mode (default 0)
B0 (LSB)	OPA_MODE	Read or Write	1 – Boost mode 0 – Charger mode (default 0)

(1) The range of the weak battery voltage threshold ($V_{(LOWV)}$) is 3.4 to 3.7 V with an offset of 3.4 V and steps of 100 mV (default 3.7 V, using bits B4 to B5).

Table 6. Control/Battery Voltage Register (Read or Write)
Memory Location: 02, Reset State: 0000 1010⁽¹⁾

BIT	NAME	Read or Write	FUNCTION
B7 (MSB)	V _{O(REG5)}	Read or Write	Battery Regulation Voltage: 640-mV step (default 0)
B6	V _{O(REG4)}	Read or Write	Battery Regulation Voltage: 320-mV step (default 0)
B5	V _{O(REG3)}	Read or Write	Battery Regulation Voltage: 160-mV step (default 0)
B4	V _{O(REG2)}	Read or Write	Battery Regulation Voltage: 80-mV step (default 0)
B3	V _{O(REG1)}	Read or Write	Battery Regulation Voltage: 40-mV step (default 1)
B2	V _{O(REG0)}	Read or Write	Battery Regulation Voltage: 20-mV step (default 0)
B1	OTG_PL	Read or Write	1 – OTG boost enable with high level 0 – OTG boost enable with low level (default 1); not applicable to OTG pin control of current limit at POR in 15-minute mode
B0 (LSB)	OTG_EN	Read or Write	1 – Enable OTG Pin in HOST mode 0 – Disable OTG pin in HOST mode (default 0), not applicable to OTG pin control of current limit at POR in 15-minute mode

(1) Charge voltage range is 3.5 to 4.44 V with the offset of 3.5 V and steps of 20 mV (default 3.54 V), using bits B2 to B7.

Table 7. Vender/Part/Revision Register (Read only)
Memory Location: 03, Reset State: 0101 000x

BIT	NAME	Read or Write	FUNCTION
B7 (MSB)	Vender2	Read only	Vender Code: bit 2 (default 0)
B6	Vender1	Read only	Vender Code: bit 1 (default 1)
B5	Vender0	Read only	Vender Code: bit 0 (default 0)
B4	PN1	Read only	For I2C Address 6AH: 01–N/A 10–bq24157S 11–N/A
B3	PN0	Read only	
B2	Revision2	Read only	
B1	Revision1	Read only	011: Revision 1.0; 001: Revision 1.1; 100 – 111: Future Revisions
B0 (LSB)	Revision0	Read only	

Table 8. Battery Termination/Fast Charge Current Register (Read or Write)
Memory Location: 04, Reset State: 0000 0001⁽¹⁾

BIT	NAME	Read or Write	FUNCTION
B7 (MSB)	Reset	Read or Write	Write: 1 – Charger in reset modes 0 – No effect, Read: always get 0
B6	V _{I(CHRG3)} ⁽²⁾	Read or Write	Charge current sense voltage: 27.2-mV step
B5	V _{I(CHRG2)} ⁽²⁾	Read or Write	Charge current sense voltage: 13.6-mV step
B4	V _{I(CHRG1)} ⁽²⁾	Read or Write	Charge current sense voltage: 6.8-mV step
B3	V _{I(CHRG0)} ⁽²⁾	Read or Write	N/A
B2	V _{I(TERM2)} ⁽³⁾	Read or Write	Termination current sense voltage: 13.6-mV step (default 0)
B1	V _{I(TERM1)} ⁽³⁾	Read or Write	Termination current sense voltage: 6.8-mV step (default 0)
B0 (LSB)	V _{I(TERM0)} ⁽³⁾	Read or Write	Termination current sense voltage: 3.4-mV step (default 1)

(1) Charge current sense voltage offset is 37.4 mV and default charge current is 550 mA, if 68-mΩ sensing resistor is used and LOW_CHG = 0.

(2) See [Table 13](#)

(3) See [Table 12](#)

Table 9. Special Charger Voltage/Enable Pin Status Register
Memory Location: 05, Reset state: 000X X100⁽¹⁾ ⁽²⁾

BIT	NAME	Read or Write	FUNCTION
B7 (MSB)	NA	Read or Write	NA
B6	FAC_MODE	Read or Write	0 – Disables factory test mode 1 – Enables the factory test mode
B5	LOW_CHG	Read or Write	0 – Normal charge current sense voltage at 04H, 1 – Low charge current sense voltage of 22.1 mV (default 0)
B4	DPM_STATUS	Read only	0 – DPM mode is not active, 1 – DPM mode is active
B3	CD_STATUS	Read only	0 – CD pin at LOW level, 1 – CD pin at HIGH level
B2	VSREG2	Read or Write	Special charger voltage: 320mV step (default 1)
B1	VSREG1	Read or Write	Special charger voltage: 160mV step (default 0)
B0 (LSB)	VSREG0	Read or Write	Special charger voltage: 80mV step (default 0)

(1) Special charger voltage offset is 4.2 V and default special charger voltage is 4.52 V.

(2) Default charge current will be 550 mA, if 68-mΩ sensing resistor is used, since default LOW_CHG = 0.

Table 10. Safety Limit Register (Read or Write, Write Only One Time After Reset)
Memory Location: 06, Reset State: 0100000

BIT	NAME	Read or Write	FUNCTION
B7 (MSB)	V _{MCHRG3} ⁽¹⁾	Read or Write	Maximum charge current sense voltage: 54.4-mV step (default 0) ⁽²⁾
B6	V _{MCHRG2} ⁽¹⁾	Read or Write	Maximum charge current sense voltage: 27.2-mV step (default 1)
B5	V _{MCHRG1} ⁽¹⁾	Read or Write	Maximum charge current sense voltage: 13.6-mV step (default 0)
B4	V _{MCHRG0} ⁽¹⁾	Read or Write	Maximum charge current sense voltage: 6.8-mV step (default 0)
B3	V _{MREG3}	Read or Write	Maximum battery regulation voltage: 160-mV step (default 0)
B2	V _{MREG2}	Read or Write	Maximum battery regulation voltage: 80-mV step (default 0)
B1	V _{MREG1}	Read or Write	Maximum battery regulation voltage: 40-mV step (default 0)
B0 (LSB)	V _{MREG0}	Read or Write	Maximum battery regulation voltage: 20-mV step (default 0)

(1) Refer to [Table 13](#)

- Maximum charge current sense voltage offset is 37.4 mV (550 mA), default at 64.6 mV (950 mA) and the maximum charge current option is 1.55 A (105.4 mV), if 55-mΩ sensing resistor is used.
- Maximum battery regulation voltage offset is 4.2 V (default at 4.2 V) and maximum battery regulation voltage option is 4.44 V.
- Memory location 06H resets only when V_(CSOUT) drops below either 1) V_(SHORT) threshold (typical 2.05 V) if V_{BUS} > V_(UVLO) or 2) the digital reset threshold (typ 2.4V) if V_{BUS} < V_(UVLO). After reset, the maximum values for battery regulation voltage and charge current can be programmed until any writing to other register locks the safety limits. Programmed values exclude higher values from memory locations 02 (battery regulation voltage), and from memory location 04 (fast charge current).
- If host accesses (write command) to some other register before safety limit register, the safety default values are used.

9 Application and Implementation

9.1 Application Information

The bq24157S is a compact, flexible, high-efficiency, USB-friendly, switch-mode charge management solution for single-cell Li-ion and Li-polymer batteries used in a wide range of portable applications. The bq24157S integrates a synchronous PWM controller, power MOSFETs, input current sensing, high-accuracy current and voltage regulation, and charge termination, into a small DSBGA package. The charge parameters can be programmed through an I²C interface.

9.2 Typical Application

$V_{BUS} = 5\text{ V}$, $I_{CHARGE} = 1250\text{ mA}$, $V_{BAT} = 3.5\text{ to }4.44\text{ V}$ (adjustable).

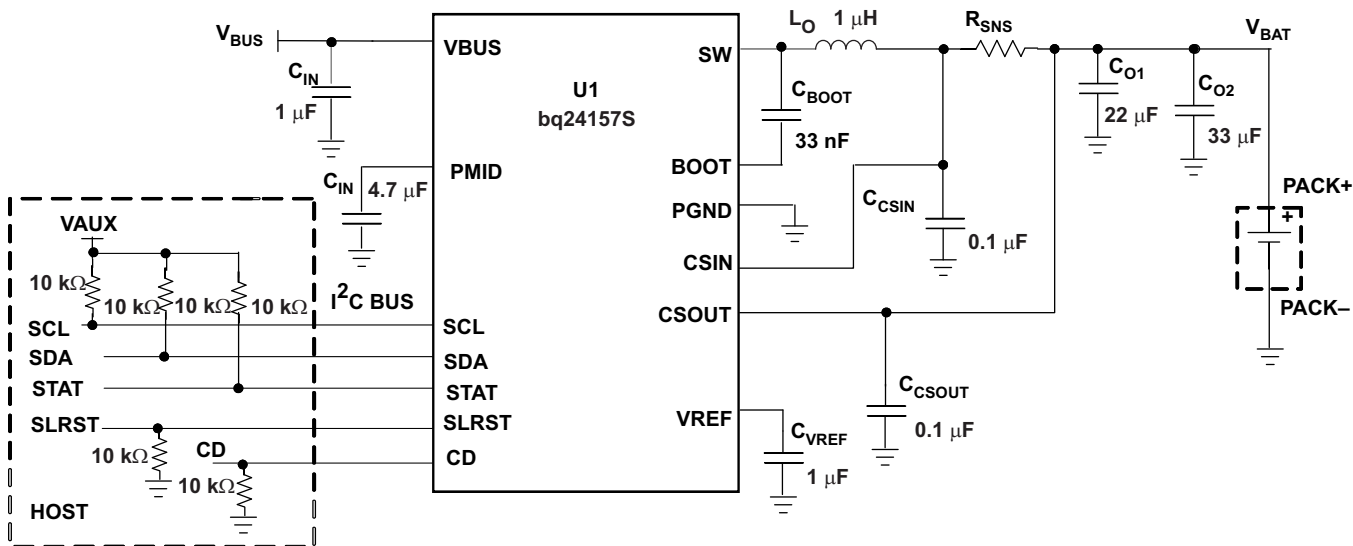

Figure 28. I²C Controlled 1-Cell USB Charger Application Circuit With USB-OTG Support

9.2.1 Design Requirements

Use the following typical application design procedure to select external components values for the bq24157S device.

Specification	Test Condition	MIN	TYP	MAX	UNIT
Input DC voltage, V_{IN}	Input voltage from AC adapter input	4	5	6	V
Input current	Maximum input current from AC adapter input	0.1	0.1 to 0.5	1.5	A
Charge current	Battery charge current	0.325	0.7	1.55	A
Output regulation voltage	Voltage applied at V_{BAT}	0	3 to 4.2	4.44	V
Operating junction temperature range, T_J		0		125	°C

9.2.2 Detailed Design Procedure

Systems design specifications:

- $V_{BUS} = 5\text{ V}$
- $V_{BAT} = 4.2\text{ V}$ (1 cell)
- $I_{(charge)} = 1.25\text{ A}$
- Inductor ripple current = 30% of fast charge current

1. Determine the inductor value (L_{OUT}) for the specified charge current ripple:

$$L_{OUT} = \frac{V_{BAT} \times (V_{BUS} - V_{BAT})}{V_{BUS} \times f \times \Delta I_L}$$

, the worst case is when battery voltage is as close as to half of the input voltage.

$$L_{OUT} = \frac{2.5 \times (5 - 2.5)}{5 \times (3 \times 10^6) \times 1.25 \times 0.3} \quad (1)$$

$$L_{OUT} = 1.11 \mu\text{H}$$

Select the output inductor to standard 1 μH . Calculate the total ripple current with using the 1- μH inductor:

$$\Delta I_L = \frac{V_{BAT} \times (V_{BUS} - V_{BAT})}{V_{BUS} \times f \times L_{OUT}} \quad (2)$$

$$\Delta I_L = \frac{2.5 \times (5 - 2.5)}{5 \times (3 \times 10^6) \times (1 \times 10^{-6})} \quad (3)$$

$$\Delta I_L = 0.42 \text{ A}$$

Calculate the maximum output current:

$$I_{LPK} = I_{OUT} + \frac{\Delta I_L}{2} \quad (4)$$

$$I_{LPK} = 1.25 + \frac{0.42}{2} \quad (5)$$

$$I_{LPK} = 1.46 \text{ A}$$

Select 2.5-mm by 2-mm, 1- μH , 1.5-A surface mount multi-layer inductor. The suggested inductor part numbers are shown in [Table 11](#).

Table 11. Inductor Part Numbers

Part Number	Inductance	Size	Manufacturer
LQM2HPN1R0MJ0	1 μH	2.5 × 2.0 mm	Murata
MIPS2520D1R0	1 μH	2.5 × 2.0 mm	FDK
MDT2520-CN1R0M	1 μH	2.5 × 2.0 mm	TOKO
CP1008	1 μH	2.5 × 2.0 mm	Inter-Technical

2. Determine the output capacitor value (C_{OUT}) using 40 kHz as the resonant frequency:

$$f_0 = \frac{1}{2\pi \times \sqrt{L_{OUT} \times C_{OUT}}} \quad (6)$$

$$C_{OUT} = \frac{1}{4\pi^2 \times f_0^2 \times L_{OUT}} \quad (7)$$

$$C_{OUT} = \frac{1}{4\pi^2 \times (40 \times 10^3)^2 \times (1 \times 10^{-6})} \quad (8)$$

$$C_{OUT} = 15.8 \mu\text{F}$$

Select two 0603 X5R 6.3-V 10- μF ceramic capacitors in parallel, that is, Murata GRM188R60J106M.

3. Determine the sense resistor using [Equation 9](#):

$$R_{(SNS)} = \frac{V_{(RSNS)}}{I_{(CHARGE)}} \quad (9)$$

The maximum sense voltage across the sense resistor is 85 mV. To get a better current regulation accuracy, $V_{(RSNS)}$ should equal 85 mV, and calculate the value for the sense resistor.

$$R_{(SNS)} = \frac{85\text{mV}}{1.25\text{A}} \tag{10}$$

$$R_{(SNS)} = 68 \text{ m}\Omega$$

This is a standard value. If it is not a standard value, then choose the next close value and calculate the real charge current. Calculate the power dissipation on the sense resistor:

$$P_{(RSNS)} = I_{(CHARGE)}^2 \times R_{(SNS)}$$

$$P_{(RSNS)} = 1.25^2 \times 0.068$$

$$P_{(RSNS)} = 0.106 \text{ W}$$

Select 0402 0.125-W 68-mΩ 2% sense resistor, that is, Panasonic ERJ2BWGR068.

For 1.5A application, $R_{(SNS)} = 85\text{mV}/1.55\text{A} = 55 \text{ m}\Omega$

4. Measured efficiency and total power loss with different inductors are shown in [Figure 29](#). SW node and inductor current waveform are shown in [Figure 36](#).

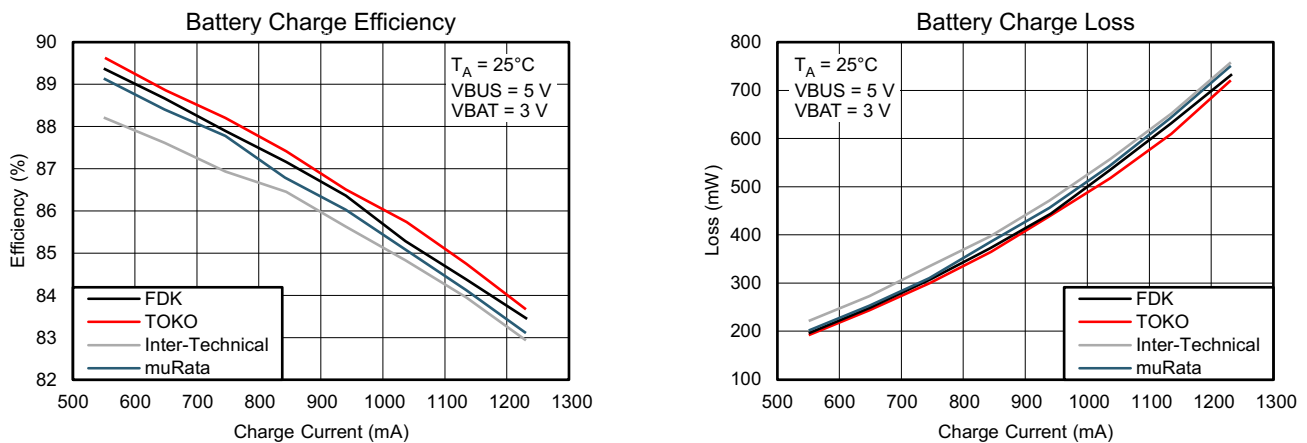

Figure 29. Measured Efficiency and Power Loss

9.2.2.1 Charge Current Sensing Resistor Selection Guidelines

Both the termination current range and charge current range depend on the sensing resistor ($R_{(SNS)}$). The termination current step ($I_{(TERM_STEP)}$) can be calculated using [Equation 11](#).

$$I_{(TERM_STEP)} = \frac{V_{I(TERM0)}}{R_{(SNS)}} \tag{11}$$

[Table 12](#) shows the termination current settings for three sensing resistors.

Table 12. Termination Current Settings for 55-mΩ, 68-mΩ, and 100-mΩ Sense Resistors

BIT	$V_{I(TERM)}$ (mV)	$I_{(TERM)}$ (mA) $R_{(SNS)} = 55 \text{ m}\Omega$	$I_{(TERM)}$ (mA) $R_{(SNS)} = 68 \text{ m}\Omega$	$I_{(TERM)}$ (mA) $R_{(SNS)} = 100 \text{ m}\Omega$
$V_{I(TERM2)}$	13.6	247	200	136
$V_{I(TERM1)}$	6.8	124	100	68
$V_{I(TERM0)}$	3.4	62	50	34
Offset	3.4	62	50	34

For example, with a 68-mΩ sense resistor, $V_{(ITERM2)} = 1$, $V_{(ITERM1)} = 0$, and $V_{(ITERM0)} = 1$, $I_{TERM} = [(13.6 \text{ mV} \times 1) + (6.8 \text{ mV} \times 0) + (3.4 \text{ mV} \times 1) + 3.4 \text{ mV}] / 68 \text{ m}\Omega = 200 \text{ mA} + 0 + 50 \text{ mA} + 50 \text{ mA} = 300 \text{ mA}$.

The charge current step ($I_{O(CHARGE_STEP)}$) is calculated using [Equation 12](#).

$$I_{O(CHARGE_STEP)} = \frac{V_{I(CHRG0)}}{R_{(SNS)}} \quad (12)$$

[Table 13](#) shows the charge current settings for three sensing resistors.

Table 13. Charge Current Settings for 55-mΩ, 68-mΩ, and 100-mΩ Sense Resistors

BIT	$V_{I(REG)}$ (mV)	$I_{O(CHARGE)}$ (mA) $R_{(SNS)} = 55 \text{ m}\Omega$	$I_{O(CHARGE)}$ (mA) $R_{(SNS)} = 68 \text{ m}\Omega$	$I_{O(CHARGE)}$ (mA) $R_{(SNS)} = 100 \text{ m}\Omega$
$V_{I(CHRG3)}$	54.4	989	800	544
$V_{I(CHRG2)}$	27.2	495	400	272
$V_{I(CHRG1)}$	13.6	247	200	136
$V_{I(CHRG0)}$	6.8	124	100	68
Offset	37.4	680	550	374

For example, with a 68-mΩ sense resistor, $V_{(CHRG3)} = 1$, $V_{(CHRG2)} = 0$, $V_{(CHRG1)} = 0$, and $V_{(CHRG0)} = 1$, $I_{TERM} = [(54.4 \text{ mV} \times 1) + (27.2 \text{ mV} \times 0) + (13.6 \text{ mV} \times 0) + (6.8 \text{ mV} \times 1) + 37.4 \text{ mV}] / 68 \text{ m}\Omega = 800 \text{ mA} + 0 + 0 + 100 \text{ mA} = 900 \text{ mA}$.

9.2.2.2 Output Inductor and Capacitance Selection Guidelines

The IC provides internal loop compensation. With the internal loop compensation, the highest stability occurs when the LC resonant frequency, f_o , is approximately 40 kHz (20 to 80 kHz). [Equation 13](#) can be used to calculate the value of the output inductor, L_{OUT} , and output capacitor, C_{OUT} .

$$f_o = \frac{1}{2\pi \times \sqrt{L_{OUT} \times C_{OUT}}} \quad (13)$$

To reduce the output voltage ripple, TI recommends a ceramic capacitor with the capacitance between 4.7 to 47 μF for C_{OUT} . See previous sections in the [Detailed Design Procedure](#) for components selection.

9.2.3 Application Curves

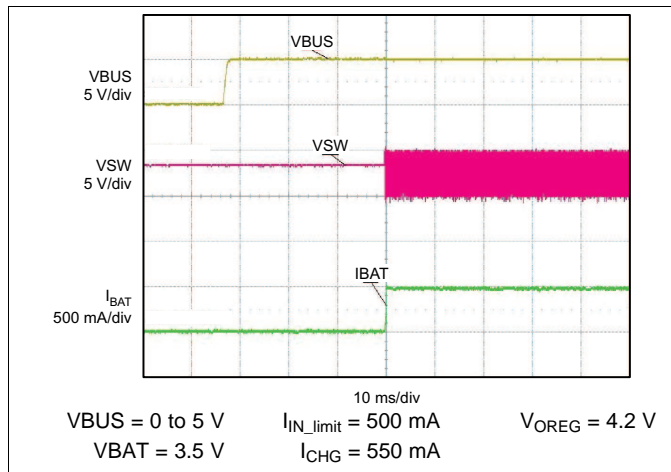

Figure 30. Adapter Insertion (32-s Mode)

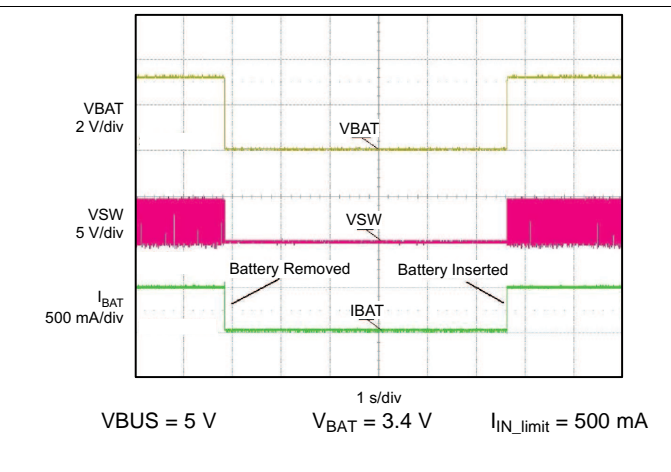

Figure 31. Battery Insertion/Removal (32-s Mode)

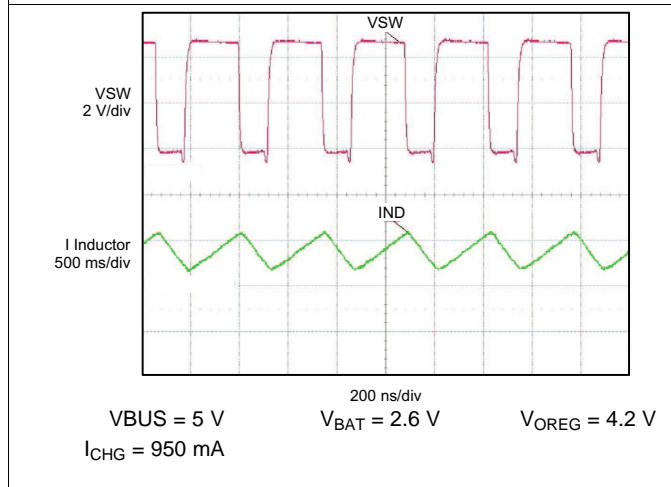

Figure 32. PWM Charging Waveforms

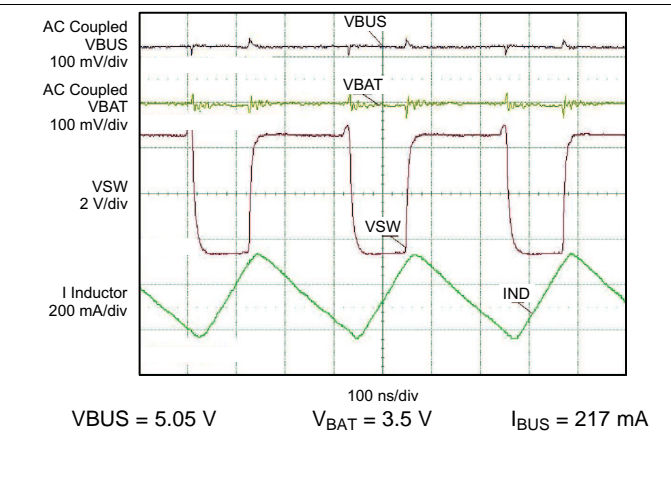

Figure 33. Boost Waveform (PWM Mode)

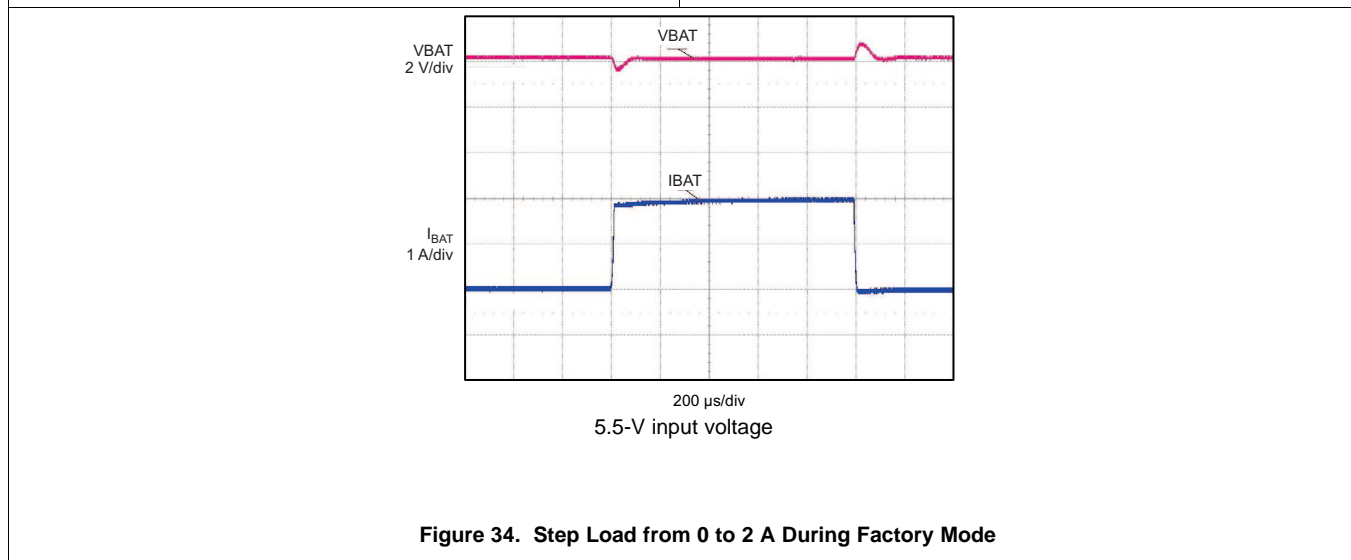

Figure 34. Step Load from 0 to 2 A During Factory Mode

10 Power Supply Recommendations

10.1 System Load After Sensing Resistor

One of the simpler high-efficiency topologies connects the system load directly across the battery pack, as shown in Figure 35. The input voltage has been converted to a usable system voltage with good efficiency from the input. When the input power is on, it supplies the system load and charges the battery pack at the same time. When the input power is off, the battery pack powers the system directly.

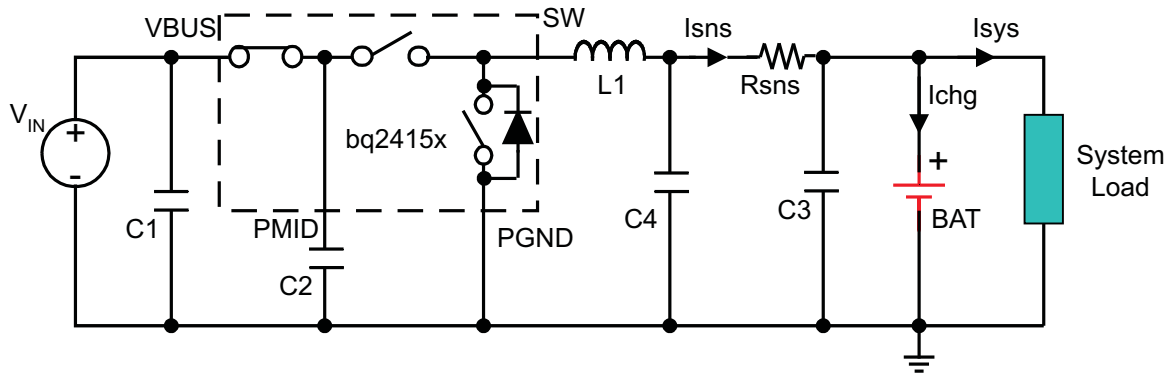

Figure 35. System Load After Sensing Resistor

The advantages:

1. When the AC adapter is disconnected, the battery pack powers the system load with minimum power dissipation. Consequently, the time that the system runs on the battery pack can be maximized.
2. It reduces the number of external path selection components and offers a low-cost solution.
3. Dynamic power management (DPM) can be achieved. The total of the charge current and the system current can be limited to a desired value by setting the charge current value. When the system current increases, the charge current drops by the same amount. As a result, no potential overcurrent or overheating issues are caused by excessive system load demand.
4. The total input current can be limited to a desired value by setting the input current limit value. USB specifications can be met easily.
5. The supply voltage variation range for the system can be minimized.
6. The input current soft-start can be achieved by the generic soft-start feature of the IC.

Design considerations and potential issues:

1. If the system always demands a high current (but lower than the regulation current), the battery charging never terminates. Thus, the battery is always charged, and its lifetime may be reduced.
2. Because the total current regulation threshold is fixed and the system always demands some current, the battery may not be charged with a full-charge rate and thus may lead to a longer charge time.
3. If the system load current is large after the charger has been terminated, the IR drop across the battery impedance may cause the battery voltage to drop below the refresh threshold and start a new charge cycle. The charger would then terminate due to low charge current. Therefore, the charger would cycle between charging and terminating. If the load is smaller, the battery has to discharge down to the refresh threshold, resulting in a much slower cycling.
4. In a charger system, the charge current is typically limited to about 30 mA, if the sensed battery voltage is below the 2-V short circuit protection threshold. This results in low power availability at the system bus. If an external supply is connected and the battery is deeply discharged below the short circuit protection threshold, the charge current is clamped to the short circuit current limit. This then is the current available to the system during the power-up phase. Most systems cannot function with such limited supply current, and the battery supplements the additional power required by the system. Note that the battery pack is already at the depleted condition, and it discharges further until the battery protector opens, resulting in a system shutdown.
5. If the battery is below the short circuit threshold and the system requires a bias current budget lower than the short circuit current limit, the end-equipment will be operational, but the charging process can be affected

System Load After Sensing Resistor (continued)

depending on the current left to charge the battery pack. Under extreme conditions, the system current is close to the short circuit current levels and the battery may not reach the fast-charge region in a timely manner. As a result, the safety timers flag the battery pack as defective, terminating the charging process. Because the safety timer cannot be disabled, the inserted battery pack must not be depleted to make the application possible.

6. If the battery pack voltage is too low, highly depleted, totally dead or even shorted, the system voltage is clamped by the battery and it cannot operate even if the input power is on.

11 Layout

11.1 Layout Guidelines

Give special attention to the PCB layout. The following list provides guidelines:

- To obtain optimal performance, the power input capacitors, connected from input to PGND, should be placed as close as possible to the pin. The output inductor should be placed close to the IC and the output capacitor connected between the inductor and PGND of the IC. The intent is to minimize the current path loop area from the SW pin through the LC filter and back to the PGND pin. To prevent high frequency oscillation problems, proper layout to minimize high frequency current path loop is critical (see [Figure 36](#)). The sense resistor should be adjacent to the junction of the inductor and output capacitor. Route the sense leads connected across the RSNS back to the IC, close to each other (minimize loop area) or on top of each other on adjacent layers (do not route the sense leads through a high-current path, see [Figure 37](#)).
- Place all decoupling capacitors close to their respective IC pins and close to PGND (do not place components such that routing interrupts power stage currents). All small control signals should be routed away from the high current paths.
- The PCB should have a ground plane (return) connected directly to the return of all components through vias (two vias per capacitor for power-stage capacitors, two vias for the IC PGND, and one via per capacitor for small-signal components). A star ground design approach is typically used to keep circuit block currents isolated (high-power/low-power small-signal), which reduces noise-coupling and ground-bounce issues. A single ground plane for this design gives good results. With this small layout and a single ground plane, there is no ground-bounce issue, and having the components segregated minimizes coupling between signals.
- The high-current charge paths into VBUS, PMID, and from the SW pins must be sized appropriately for the maximum charge current in order to avoid voltage drops in these traces. The PGND pins should be connected to the ground plane to return current through the internal low-side FET.
- Place 4.7- μF input capacitor as close to PMID pin and PGND pin as possible to make the high frequency current loop area as small as possible. Place 1- μF input capacitor as close to VBUS pin and PGND pin as possible to make high frequency current loop area as small as possible (see [Figure 38](#)).

11.2 Layout Example

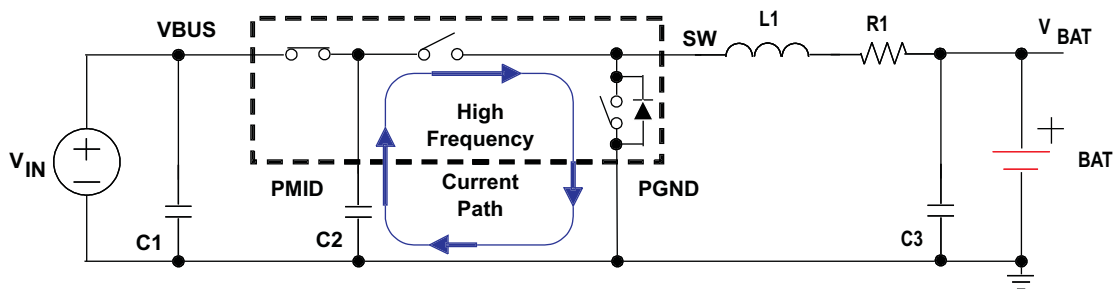

Figure 36. High Frequency Current Path

Layout Example (接下页)

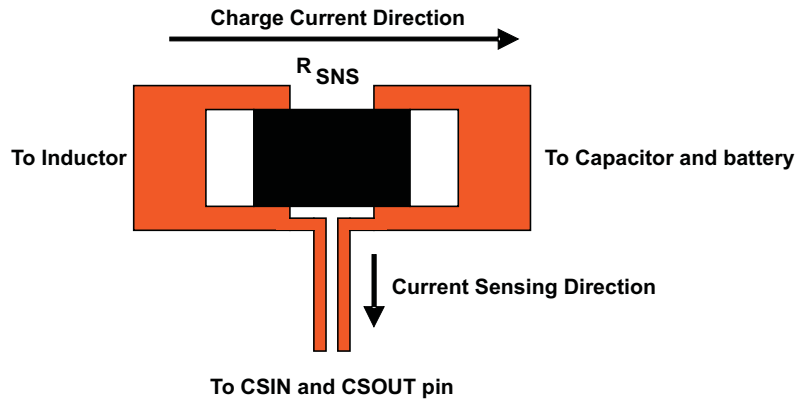

Figure 37. Sensing Resistor PCB Layout

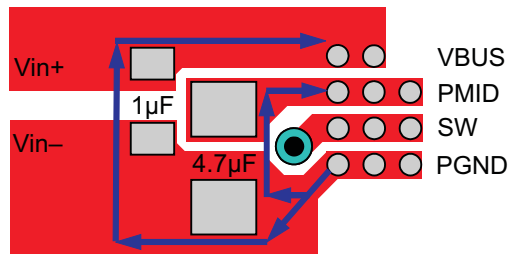

Figure 38. Input Capacitor Position and PCB Layout Example

12 器件和文档支持

12.1 器件支持

12.1.1 第三方产品免责声明

TI 发布的与第三方产品或服务有关的信息，不能构成与此类产品或服务或保修的适用性有关的认可，不能构成此类产品或服务单独或与任何 TI 产品或服务一起的表示或认可。

12.2 文档支持

12.2.1 相关文档

《bq24157S 用户指南》([SLUU453](#))

12.3 商标

NanoFree is a trademark of Texas Instruments.

12.4 静电放电警告



这些装置包含有限的内置 ESD 保护。存储或装卸时，应将导线一起截短或将装置放置于导电泡棉中，以防止 MOS 门极遭受静电损伤。

12.5 术语表

[SLYZ022](#) — TI 术语表。

这份术语表列出并解释术语、首字母缩略词和定义。

13 机械封装和可订购信息

以下页中包括机械封装和可订购信息。 这些信息是针对指定器件可提供的最新数据。 这些数据会在无通知且不对本文档进行修订的情况下发生改变。 欲获得该数据表的浏览器版本，请查阅左侧的导航栏。

13.1 封装概要

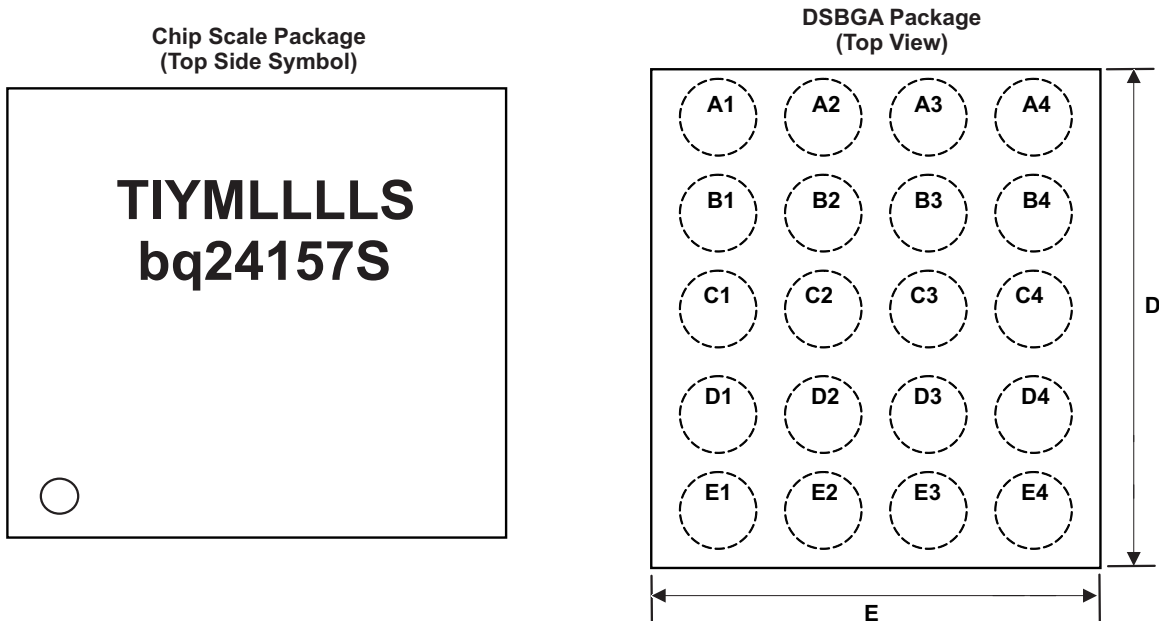

0 引脚 A1 标记, TI-TI 字符, YM = 年月日日期代码, LLL = 批次追踪代码, S = 组装地点代码

13.1.1 芯片尺寸级封装尺寸

bq24157S 器件采用 20 焊锡凸块芯片尺寸封装 (DSBGA, NanoFree™)。

封装尺寸为:

D	E
最大值 = 2.17mm	最大值 = 2.03mm
最小值 = 2.11mm	最小值 = 1.97mm

重要声明

德州仪器(TI)及其下属子公司有权根据 JESD46 最新标准,对所提供的产品和服务进行更正、修改、增强、改进或其它更改,并有权根据 JESD48 最新标准中止提供任何产品和服务。客户在下订单前应获取最新的相关信息,并验证这些信息是否完整且是最新的。所有产品的销售都遵循在订单确认时所提供的TI 销售条款与条件。

TI 保证其所销售的组件的性能符合产品销售时 TI 半导体产品销售条件与条款的适用规范。仅在 TI 保证的范围内,且 TI 认为有必要时才会使用测试或其它质量控制技术。除非适用法律做出了硬性规定,否则没有必要对每种组件的所有参数进行测试。

TI 对应用帮助或客户产品设计不承担任何义务。客户应对其使用 TI 组件的产品和应用自行负责。为尽量减小与客户产品和应用相关的风险,客户应提供充分的设计与操作安全措施。

TI 不对任何 TI 专利权、版权、屏蔽作品权或其它与使用了 TI 组件或服务的组合设备、机器或流程相关的 TI 知识产权中授予的直接或隐含权限作出任何保证或解释。TI 所发布的与第三方产品或服务有关的信息,不能构成从 TI 获得使用这些产品或服务的许可、授权、或认可。使用此类信息可能需要获得第三方的专利权或其它知识产权方面的许可,或是 TI 的专利权或其它知识产权方面的许可。

对于 TI 的产品手册或数据表中 TI 信息的重要部分,仅在没有对内容进行任何篡改且带有相关授权、条件、限制和声明的情况下才允许进行复制。TI 对此类篡改过的文件不承担任何责任或义务。复制第三方的信息可能需要服从额外的限制条件。

在转售 TI 组件或服务时,如果对该组件或服务参数的陈述与 TI 标明的参数相比存在差异或虚假成分,则会失去相关 TI 组件或服务的所有明示或暗示授权,且这是不正当的、欺诈性商业行为。TI 对任何此类虚假陈述均不承担任何责任或义务。

客户认可并同意,尽管任何应用相关信息或支持仍可能由 TI 提供,但他们将独立负责满足与其产品及其在应用中使用的 TI 产品相关的所有法律、法规和安全相关要求。客户声明并同意,他们具备制定与实施安全措施所需的全部专业技术和知识,可预见故障的危险后果、监测故障及其后果、降低有可能造成人身伤害的故障的发生机率并采取适当的补救措施。客户将全额赔偿因在此类安全关键应用中使用任何 TI 组件而对 TI 及其代理造成的任何损失。

在某些场合中,为了推进安全相关应用有可能对 TI 组件进行特别的促销。TI 的目标是利用此类组件帮助客户设计和创立其特有的可满足适用的功能安全性标准和要求的终端产品解决方案。尽管如此,此类组件仍然服从这些条款。

TI 组件未获得用于 FDA Class III (或类似的生命攸关医疗设备)的授权许可,除非各方授权官员已经达成了专门管控此类使用的特别协议。

只有那些 TI 特别注明属于军用等级或“增强型塑料”的 TI 组件才是设计或专门用于军事/航空应用或环境的。购买者认可并同意,对并非指定面向军事或航空航天用途的 TI 组件进行军事或航空航天方面的应用,其风险由客户单独承担,并且由客户独立负责满足与此类使用相关的所有法律和法规要求。

TI 已明确指定符合 ISO/TS16949 要求的产品,这些产品主要用于汽车。在任何情况下,因使用非指定产品而无法达到 ISO/TS16949 要求, TI 不承担任何责任。

	产品		应用
数字音频	www.ti.com.cn/audio	通信与电信	www.ti.com.cn/telecom
放大器和线性器件	www.ti.com.cn/amplifiers	计算机及周边	www.ti.com.cn/computer
数据转换器	www.ti.com.cn/dataconverters	消费电子	www.ti.com.cn/consumer-apps
DLP® 产品	www.dlp.com	能源	www.ti.com.cn/energy
DSP - 数字信号处理器	www.ti.com.cn/dsp	工业应用	www.ti.com.cn/industrial
时钟和计时器	www.ti.com.cn/clockandtimers	医疗电子	www.ti.com.cn/medical
接口	www.ti.com.cn/interface	安防应用	www.ti.com.cn/security
逻辑	www.ti.com.cn/logic	汽车电子	www.ti.com.cn/automotive
电源管理	www.ti.com.cn/power	视频和影像	www.ti.com.cn/video
微控制器 (MCU)	www.ti.com.cn/microcontrollers		
RFID 系统	www.ti.com.cn/rfidsys		
OMAP应用处理器	www.ti.com/omap		
无线连通性	www.ti.com.cn/wirelessconnectivity	德州仪器在线技术支持社区	www.deyisupport.com

邮寄地址: 上海市浦东新区世纪大道1568号, 中建大厦32楼邮政编码: 200122
Copyright © 2015, 德州仪器半导体技术(上海)有限公司

PACKAGING INFORMATION

Orderable Device	Status (1)	Package Type	Package Drawing	Pins	Package Qty	Eco Plan (2)	Lead/Ball Finish (6)	MSL Peak Temp (3)	Op Temp (°C)	Device Marking (4/5)	Samples
BQ24157SYFFR	NRND	DSBGA	YFF	20	3000	Green (RoHS & no Sb/Br)	SNAGCU	Level-1-260C-UNLIM		BQ24157S	
BQ24157SYFFT	NRND	DSBGA	YFF	20	250	Green (RoHS & no Sb/Br)	SNAGCU	Level-1-260C-UNLIM		BQ24157S	

(1) The marketing status values are defined as follows:

ACTIVE: Product device recommended for new designs.

LIFEBUY: TI has announced that the device will be discontinued, and a lifetime-buy period is in effect.

NRND: Not recommended for new designs. Device is in production to support existing customers, but TI does not recommend using this part in a new design.

PREVIEW: Device has been announced but is not in production. Samples may or may not be available.

OBSOLETE: TI has discontinued the production of the device.

(2) Eco Plan - The planned eco-friendly classification: Pb-Free (RoHS), Pb-Free (RoHS Exempt), or Green (RoHS & no Sb/Br) - please check <http://www.ti.com/productcontent> for the latest availability information and additional product content details.

TBD: The Pb-Free/Green conversion plan has not been defined.

Pb-Free (RoHS): TI's terms "Lead-Free" or "Pb-Free" mean semiconductor products that are compatible with the current RoHS requirements for all 6 substances, including the requirement that lead not exceed 0.1% by weight in homogeneous materials. Where designed to be soldered at high temperatures, TI Pb-Free products are suitable for use in specified lead-free processes.

Pb-Free (RoHS Exempt): This component has a RoHS exemption for either 1) lead-based flip-chip solder bumps used between the die and package, or 2) lead-based die adhesive used between the die and leadframe. The component is otherwise considered Pb-Free (RoHS compatible) as defined above.

Green (RoHS & no Sb/Br): TI defines "Green" to mean Pb-Free (RoHS compatible), and free of Bromine (Br) and Antimony (Sb) based flame retardants (Br or Sb do not exceed 0.1% by weight in homogeneous material)

(3) MSL, Peak Temp. - The Moisture Sensitivity Level rating according to the JEDEC industry standard classifications, and peak solder temperature.

(4) There may be additional marking, which relates to the logo, the lot trace code information, or the environmental category on the device.

(5) Multiple Device Markings will be inside parentheses. Only one Device Marking contained in parentheses and separated by a "~" will appear on a device. If a line is indented then it is a continuation of the previous line and the two combined represent the entire Device Marking for that device.

(6) Lead/Ball Finish - Orderable Devices may have multiple material finish options. Finish options are separated by a vertical ruled line. Lead/Ball Finish values may wrap to two lines if the finish value exceeds the maximum column width.

Important Information and Disclaimer: The information provided on this page represents TI's knowledge and belief as of the date that it is provided. TI bases its knowledge and belief on information provided by third parties, and makes no representation or warranty as to the accuracy of such information. Efforts are underway to better integrate information from third parties. TI has taken and continues to take reasonable steps to provide representative and accurate information but may not have conducted destructive testing or chemical analysis on incoming materials and chemicals. TI and TI suppliers consider certain information to be proprietary, and thus CAS numbers and other limited information may not be available for release.

In no event shall TI's liability arising out of such information exceed the total purchase price of the TI part(s) at issue in this document sold by TI to Customer on an annual basis.

TAPE AND REEL INFORMATION

QUADRANT ASSIGNMENTS FOR PIN 1 ORIENTATION IN TAPE

*All dimensions are nominal

Device	Package Type	Package Drawing	Pins	SPQ	Reel Diameter (mm)	Reel Width W1 (mm)	A0 (mm)	B0 (mm)	K0 (mm)	P1 (mm)	W (mm)	Pin1 Quadrant
BQ24157SYFFR	DSBGA	YFF	20	3000	180.0	8.4	2.2	2.35	0.8	4.0	8.0	Q1
BQ24157SYFFT	DSBGA	YFF	20	250	180.0	8.4	2.2	2.35	0.8	4.0	8.0	Q1

TAPE AND REEL BOX DIMENSIONS

*All dimensions are nominal

Device	Package Type	Package Drawing	Pins	SPQ	Length (mm)	Width (mm)	Height (mm)
BQ24157SYFFR	DSBGA	YFF	20	3000	182.0	182.0	20.0
BQ24157SYFFT	DSBGA	YFF	20	250	182.0	182.0	20.0

YFF (R-XBGA-N20)

DIE-SIZE BALL GRID ARRAY

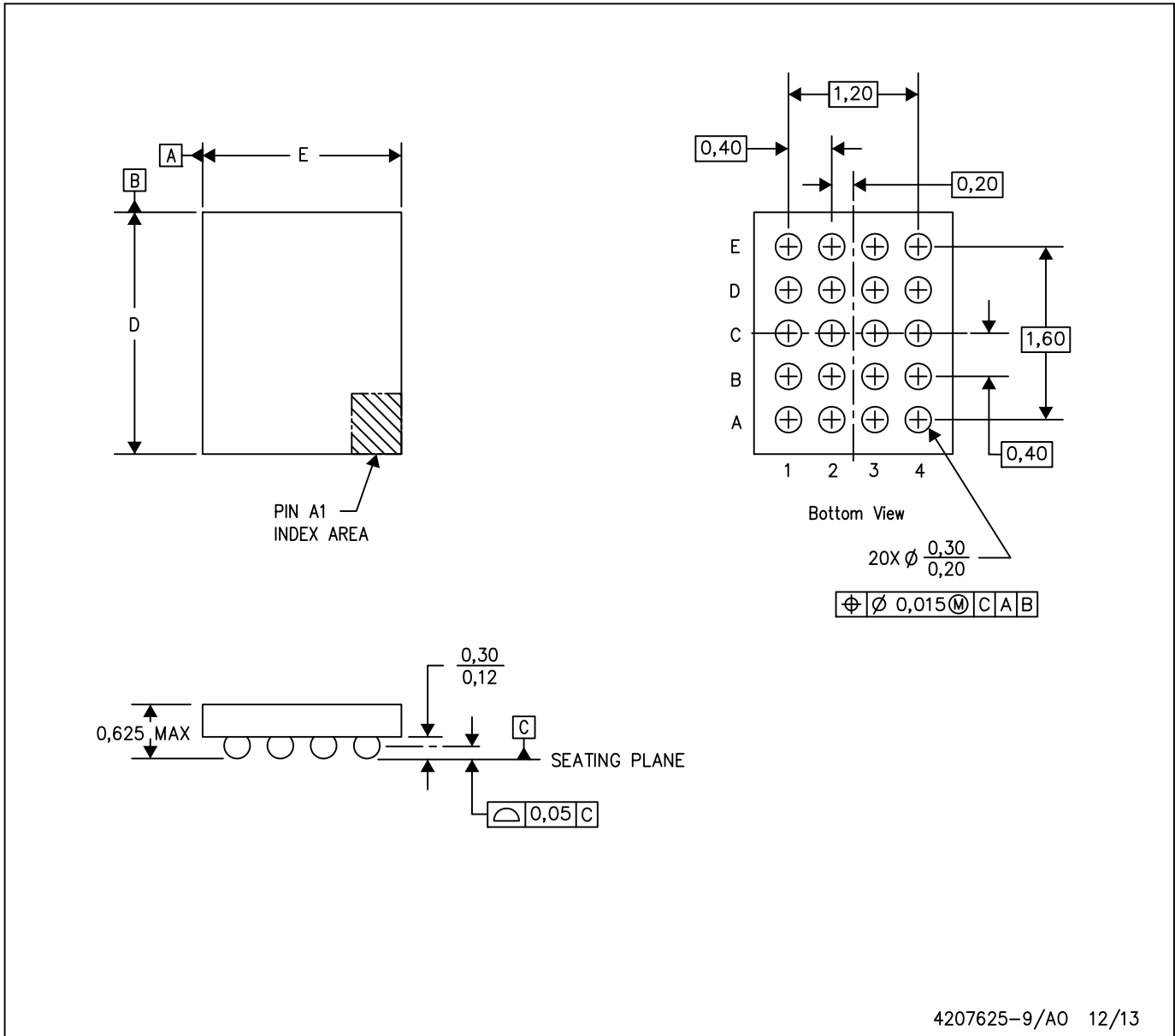

- NOTES: A. All linear dimensions are in millimeters. Dimensioning and tolerancing per ASME Y14.5M-1994.
 B. This drawing is subject to change without notice.
 C. NanoFree™ package configuration.

NanoFree is a trademark of Texas Instruments.

重要声明

德州仪器(TI) 及其下属子公司有权根据 JESD46 最新标准, 对所提供的产品和服务进行更正、修改、增强、改进或其它更改, 并有权根据 JESD48 最新标准中止提供任何产品和服务。客户在下订单前应获取最新的相关信息, 并验证这些信息是否完整且是最新的。所有产品的销售都遵循在订单确认时所提供的TI 销售条款与条件。

TI 保证其所销售的组件的性能符合产品销售时 TI 半导体产品销售条件与条款的适用规范。仅在 TI 保证的范围内, 且 TI 认为有必要时才会使用测试或其它质量控制技术。除非适用法律做出了硬性规定, 否则没有必要对每种组件的所有参数进行测试。

TI 对应用帮助或客户产品设计不承担任何义务。客户应对其使用 TI 组件的产品和应用自行负责。为尽量减小与客户产品和应用相关的风险, 客户应提供充分的设计与操作安全措施。

TI 不对任何 TI 专利权、版权、屏蔽作品权或其它与使用了 TI 组件或服务的组合设备、机器或流程相关的 TI 知识产权中授予的直接或间接版权限作出任何保证或解释。TI 所发布的与第三方产品或服务有关的信息, 不能构成从 TI 获得使用这些产品或服务的许可、授权、或认可。使用此类信息可能需要获得第三方的专利权或其它知识产权方面的许可, 或是 TI 的专利权或其它知识产权方面的许可。

对于 TI 的产品手册或数据表中 TI 信息的重要部分, 仅在没有对内容进行任何篡改且带有相关授权、条件、限制和声明的情况下才允许进行复制。TI 对此类篡改过的文件不承担任何责任或义务。复制第三方的信息可能需要服从额外的限制条件。

在转售 TI 组件或服务时, 如果对该组件或服务参数的陈述与 TI 标明的参数相比存在差异或虚假成分, 则会失去相关 TI 组件或服务的所有明示或暗示授权, 且这是不正当的、欺诈性商业行为。TI 对任何此类虚假陈述均不承担任何责任或义务。

客户认可并同意, 尽管任何应用相关信息或支持仍可能由 TI 提供, 但他们将独自负责满足与其产品及其应用中使用 TI 产品相关的所有法律、法规和安全相关要求。客户声明并同意, 他们具备制定与实施安全措施所需的全部专业技术和知识, 可预见故障的危险后果、监测故障及其后果、降低有可能造成人身伤害的故障的发生机率并采取适当的补救措施。客户将全额赔偿因在此类安全关键应用中使用任何 TI 组件而对 TI 及其代理造成的任何损失。

在某些场合中, 为了推进安全相关应用有可能对 TI 组件进行特别的促销。TI 的目标是利用此类组件帮助客户设计和创立其特有的可满足适用的功能安全性标准和要求的终端产品解决方案。尽管如此, 此类组件仍然服从这些条款。

TI 组件未获得用于 FDA Class III (或类似的生命攸关医疗设备) 的授权许可, 除非各方授权官员已经达成了专门管控此类使用的特别协议。

只有那些 TI 特别注明属于军用等级或“增强型塑料”的 TI 组件才是设计或专门用于军事/航空应用或环境的。购买者认可并同意, 对并非指定面向军事或航空航天用途的 TI 组件进行军事或航空航天方面的应用, 其风险由客户单独承担, 并且由客户独自负责满足与此类使用相关的所有法律和法规要求。

TI 已明确指定符合 ISO/TS16949 要求的产品, 这些产品主要用于汽车。在任何情况下, 因使用非指定产品而无法达到 ISO/TS16949 要求, TI 不承担任何责任。

	产品		应用
数字音频	www.ti.com.cn/audio	通信与电信	www.ti.com.cn/telecom
放大器和线性器件	www.ti.com.cn/amplifiers	计算机及周边	www.ti.com.cn/computer
数据转换器	www.ti.com.cn/dataconverters	消费电子	www.ti.com.cn/consumer-apps
DLP® 产品	www.dlp.com	能源	www.ti.com.cn/energy
DSP - 数字信号处理器	www.ti.com.cn/dsp	工业应用	www.ti.com.cn/industrial
时钟和计时器	www.ti.com.cn/clockandtimers	医疗电子	www.ti.com.cn/medical
接口	www.ti.com.cn/interface	安防应用	www.ti.com.cn/security
逻辑	www.ti.com.cn/logic	汽车电子	www.ti.com.cn/automotive
电源管理	www.ti.com.cn/power	视频和影像	www.ti.com.cn/video
微控制器 (MCU)	www.ti.com.cn/microcontrollers		
RFID 系统	www.ti.com.cn/rfidsys		
OMAP应用处理器	www.ti.com.cn/omap		
无线连通性	www.ti.com.cn/wirelessconnectivity	德州仪器在线技术支持社区	www.deyisupport.com

Mailing Address: Texas Instruments, Post Office Box 655303, Dallas, Texas 75265
Copyright © 2015, Texas Instruments Incorporated