

CURRENT MODE PWM CONTROLLER (KNOWN GOOD DIE)

FEATURES

- **–55°C to 125°C Known Good Die**
- **Controlled Baseline**
- **Optimized For Off-line and DC-to-DC Converters**
- **Low Start-Up Current (<1 mA)**
- **Automatic Feed Forward Compensation**
- **Pulse-by-Pulse Current Limiting**
- **Enhanced Load Response Characteristics**
- **Under-Voltage Lockout With Hysteresis**
- **Double Pulse Suppression**
- **High Current Totem Pole Output**
- **Internally Trimmed Bandgap Reference**
- **500-kHz Operation**
- **Low R_O Error Amp**

DESCRIPTION

The UC1843 family of control devices provides the necessary features to implement off-line or dc-to-dc fixed frequency current mode control schemes with a minimal external parts count. Internally implemented circuits include under-voltage lockout featuring start up current less than 1 mA, a precision reference trimmed for accuracy at the error amp input, logic to insure latched operation, a PWM comparator which also provides current limit control, and a totem pole output stage designed to source or sink high peak current. The output stage, suitable for driving N-Channel MOSFETs, is low in the off state. The under-voltage lockout threshold is 8.4 V and maximum duty cycle range is around 100%.

BLOCK DIAGRAM

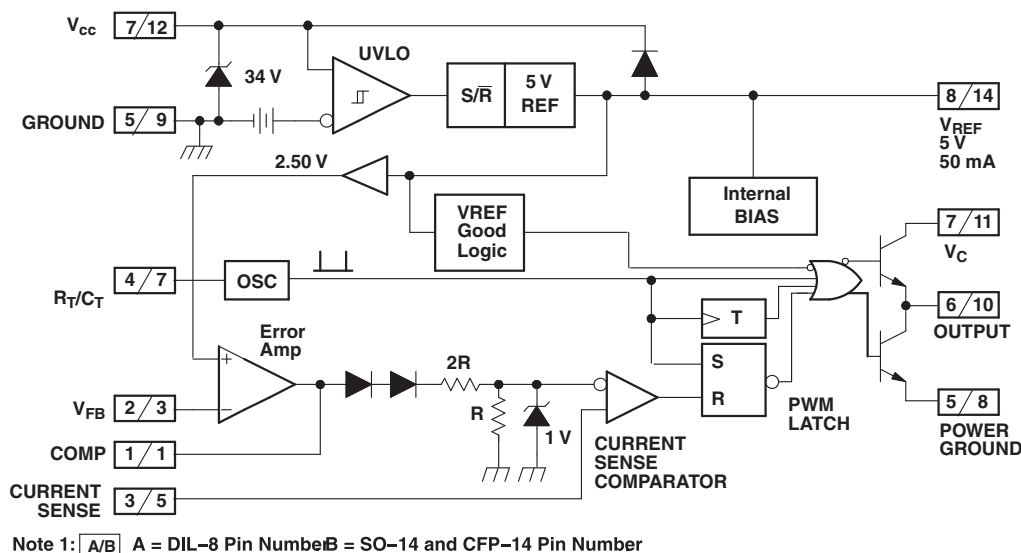

ORDERING INFORMATION⁽¹⁾

T_A	PACKAGE ⁽²⁾	ORDERABLE PART NUMBER	TOP-SIDE MARKING
–55°C to 125°C	KGD	UC1843KGD1	NA

(1) For the most current package and ordering information, see the Package Option Addendum at the end of this document, or see the TI website at www.ti.com.

(2) Package drawings, thermal data, and symbolization are available at www.ti.com/packaging.



Please be aware that an important notice concerning availability, standard warranty, and use in critical applications of Texas Instruments semiconductor products and disclaimers thereto appears at the end of this data sheet.

BARE DIE INFORMATION

DIE THICKNESS	BACKSIDE FINISH	BACKSIDE POTENTIAL	BOND PAD METALLIZATION COMPOSITION
15 mils.	Silicon with backgrind	GND	Al-Si-Cu (0.5%)

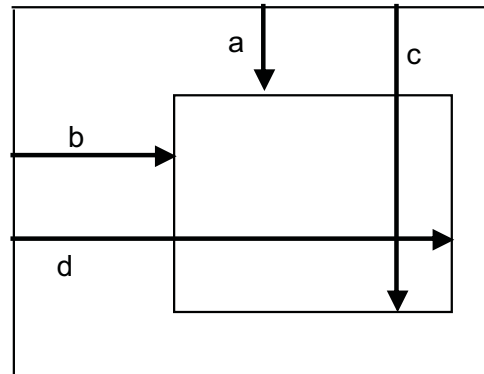

Origin

BOND PAD COORDINATES (in Mils)

DESCRIPTION	PAD NUMBER	a	b	c	d
COMP	1	78.70	63.40	82.90	67.60
V_{FB}	2	70.60	63.40	74.80	67.60
I_{SENSE}	3	39.40	63.40	43.60	67.60
R_T/C_T	4	18.60	61.20	22.60	65.60
GROUND	5	17.80	11.70	22.00	15.90
GROUND	6	17.40	3.90	21.80	8.10
OUTPUT	7	32.60	6.40	36.80	10.60
V_{CC}	8	47.50	6.40	51.70	10.60
V_{CC}	9	54.60	6.40	58.80	10.60
V_{REF}	10	68.70	6.40	72.90	10.60
NC	TESTPAD	87.10	6.30	90.80	10.30
NC	TESTPAD	87.10	12.60	90.80	16.60
NC	TESTPAD	87.10	18.00	90.80	22.00
NC	TESTPAD	87.10	24.30	90.80	28.30
NC	TESTPAD	87.10	30.60	90.80	34.60

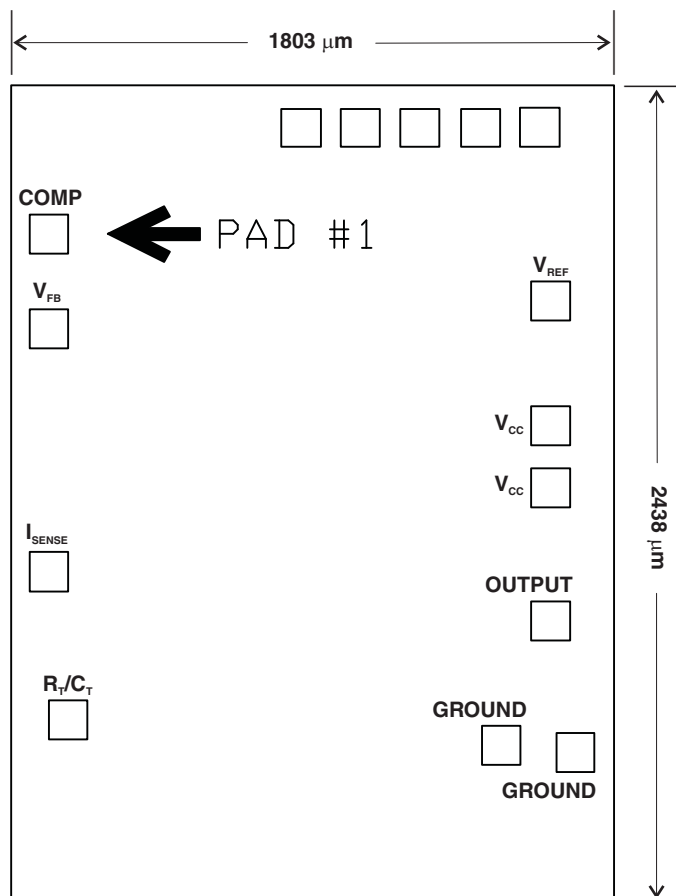

ABSOLUTE MAXIMUM RATINGS

		UNIT
Supply voltage	Low impedance source	30 V
	$I_{CC} < 30 \text{ mA}$	Self Limiting
Output current		$\pm 1 \text{ A}$
Output energy (capacitive load)		5 μJ
Analog inputs (Pins 2, 3)		-0.3 V to 6.3 V
Error amp output sink current		10 mA
Storage temperature range		-65°C to 150°C
Junction temperature range		-55°C to 150°C

ELECTRICAL CHARACTERISTICS

Unless otherwise stated, these specifications apply for $-55^{\circ}\text{C} \leq T_A \leq 125^{\circ}\text{C}$; $V_{CC} = 15\text{ V}^{(1)}$; $R_T = 10\text{ kW}$; $C_T = 3.3\text{ nF}$, $T_A = T_J$.

PARAMETER	TEST CONDITIONS	MIN	TYP	MAX	UNIT
REFERENCE SECTION					
Output Voltage	$T_J = 25^{\circ}\text{C}$, $I_O = 1\text{ mA}$	4.95	5.00	5.05	V
Line Regulation	$12 \leq V_{IN} \leq 25\text{ V}$		6	20	mV
Load Regulation	$1 \leq I_O \leq 20\text{ mA}$		6	25	
Temperature Stability	See ⁽²⁾⁽³⁾		0.2	0.4	mV/ $^{\circ}\text{C}$
Total Output Variation	Line, load, tempature ⁽²⁾	4.9		5.1	V
Output Noise Voltage	$10\text{ Hz} \leq f \leq 10\text{ kHz}$, $T_J = 25^{\circ}\text{C}$ ⁽²⁾		50		μV
Long Term Stability	$T_A = 125^{\circ}\text{C}$, 1000 Hrs ⁽²⁾		5	25	mV
Output Short Circuit		-30	-100	-180	mA
OSCILLATOR SECTION					
Initial Accuracy	$T_J = 25^{\circ}\text{C}^{(4)}$	47	52	57	kHz
Voltage Stability	$12 \leq V_{CC} \leq 25\text{ V}$		0.2%	1%	
Temperature Stability	$T_{MIN} \leq T_A \leq T_{MAX}$ ⁽²⁾		5%		
Amplitude	$V_{PIN\ 4}$ peak-to-peak ⁽²⁾		1.7		V
ERROR AMP SECTION					
Input Voltage	$V_{PIN\ 1} = 2.5\text{ V}$	2.45	2.50	2.55	V
Input Bias Current			-0.3	-1	
A_{VOL}	$2 \leq V_O \leq 4\text{ V}$	65	90		dB
Unity Gain Bandwidth	$T_J = 25^{\circ}\text{C}$ ⁽²⁾	0.7	1		
PSRR	$12 \leq V_{CC} \leq 25\text{ V}$	60	70		dB
Output Sink Current	$V_{PIN\ 2} = 2.7\text{ V}$, $V_{PIN\ 1} = 1.1\text{ V}$	2	6		
Output Source Current	$V_{PIN\ 2} = 2.3\text{ V}$, $V_{PIN\ 1} = 5\text{ V}$	-0.5	-0.8		mA
$V_{OUT\ High}$	$V_{PIN\ 2} = 2.3\text{ V}$, $R_L = 15\text{ k}\Omega$ to ground	5	6		
$V_{OUT\ Low}$	$V_{PIN\ 2} = 2.7\text{ V}$, $R_L = 15\text{ k}\Omega$ to Pin 8		0.7	1.1	V
CURRENT SENSE SECTION					
Gain	See ⁽⁵⁾⁽⁶⁾	2.85	3	3.15	V/V
Maximum Input Signal	$V_{PIN\ 1} = 5\text{ V}$ ⁽⁵⁾	0.9	1	1.1	V
PSRR	$12 \leq V_{CC} \leq 25\text{ V}$ ⁽²⁾⁽⁵⁾		70		
Input Bias Current			-2	-10	μA
Delay to Output	$V_{PIN\ 3} = 0\text{ V}$ to 2 V ⁽²⁾		150	300	
OUTPUT SECTION					
Output Low Level	$I_{SINK} = 20\text{ mA}$		0.1	0.4	V
	$I_{SINK} = 200\text{ mA}$		1.5	2.2	
Output High Level	$I_{SOURCE} = 20\text{ mA}$	13	13.5		
	$I_{SOURCE} = 200\text{ mA}$	12	13.5		
Rise Time	$T_J = 25^{\circ}\text{C}$, $C_L = 1\text{ nF}$ ⁽²⁾		50	150	ns
Fall Time	$T_J = 25^{\circ}\text{C}$, $C_L = 1\text{ nF}$ ⁽²⁾		50	150	

(1) Adjust V_{CC} above the start threshold before setting at 15 V.

(2) These parameters, although specified, are not 100% tested in production.

(3) Temperature stability, sometimes referred to as average temperature coefficient, is described by the equation:

$$\text{Temp Stability} = \frac{V_{REF(\text{max})} - V_{REF(\text{min})}}{T_J(\text{max}) - T_J(\text{min})}$$

$V_{REF(\text{max})}$ and $V_{REF(\text{min})}$ are the maximum and minimum reference voltages measured over the appropriate temperature range. Note that the extremes in voltage do not necessarily occur at the extremes in temperature.

(4) Output frequency equals oscillator frequency.

(5) Parameter measured at trip point of latch with $V_{PIN\ 2} = 0$.

$$A = \frac{\Delta V_{PIN\ 1}}{\Delta V_{PIN\ 3}}, \quad 0 \leq V_{PIN\ 3} \leq 0.8\text{ V}$$

(6) Gain defined as:

ELECTRICAL CHARACTERISTICS (continued)

Unless otherwise stated, these specifications apply for $-55^{\circ}\text{C} \leq T_A \leq 125^{\circ}\text{C}$; $V_{CC} = 15\text{ V}$; $R_T = 10\text{ kW}$; $C_T = 3.3\text{ nF}$, $T_A = T_J$.

PARAMETER	TEST CONDITIONS	MIN	TYP	MAX	UNIT
UNDER-VOLTAGE LOCKOUT SECTION					
Start Threshold		7.8	8.4	9.0	V
Min. Operating Voltage After Turn On		7.0	7.6	8.2	
PWM SECTION					
Maximum Duty Cycle		95%	97%	100%	
Minimum Duty Cycle				0%	
TOTAL STANDBY CURRENT					
Start-Up Current			0.5	1	mA
Operating Supply Current	$V_{PIN\ 2} = V_{PIN\ 3} = 0\text{ V}$		11	17	
V_{CC} Zener Voltager	$I_{CC} = 25\text{ mA}$	30	34		V

ERROR AMP CONFIGURATION

Error amp can source or sink up to 0.5 mA.

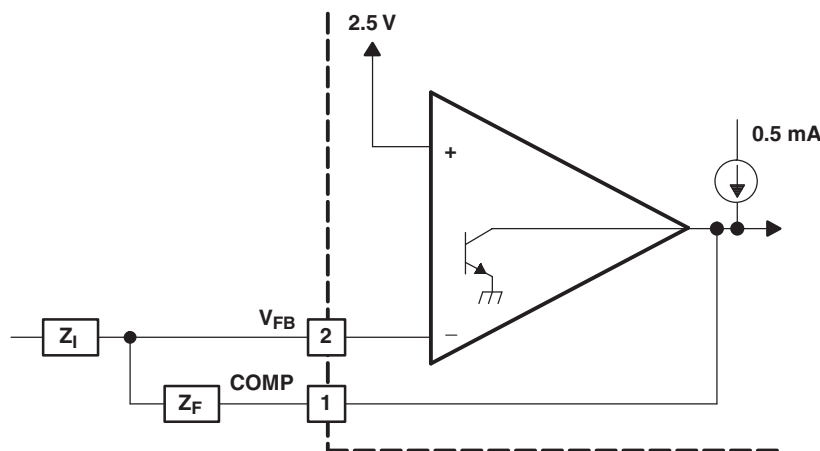

UNDER-VOLTAGE LOCKOUT

During under-voltage lock-out, the output drive is biased to sink minor amounts of current. Pin 6 should be shunted to ground with a bleeder resistor to prevent activating the power switch with extraneous leakage currents.

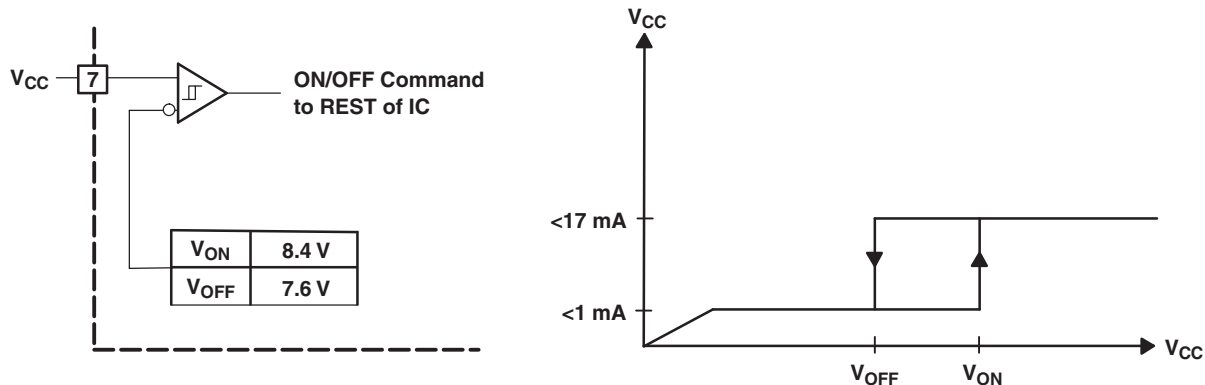

CURRENT SENSE CIRCUIT

A small RC filter may be required to suppress switch transients.

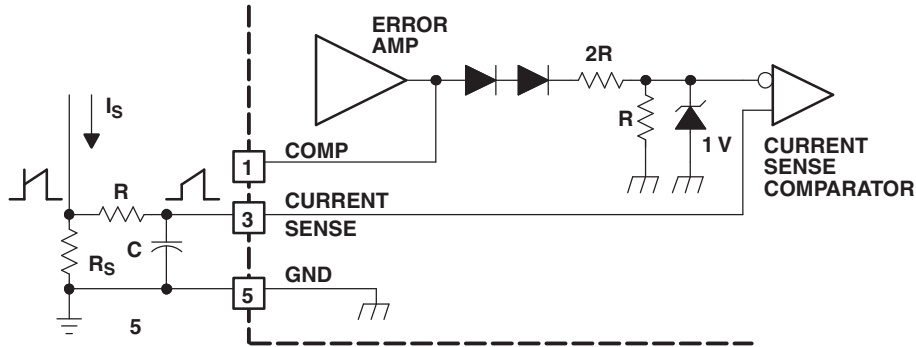

Peak Current (I_S) is Determined By The Formula

$$I_{S\text{MAX}} = \frac{.1.0 \text{ V}}{R_S}$$

OSCILLATOR SECTION

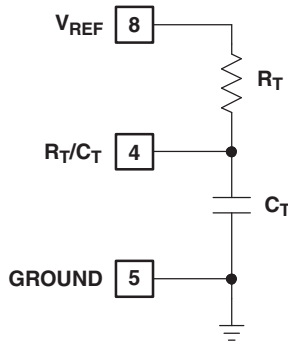

For $R_T > 5 \text{ K } f \sim \frac{1.72}{R_T C_T}$

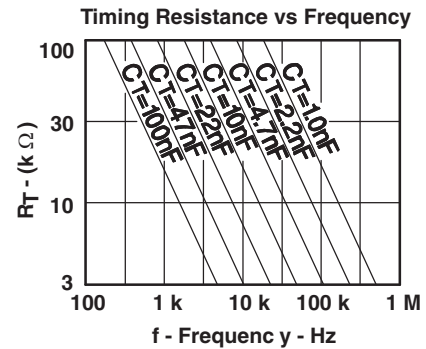
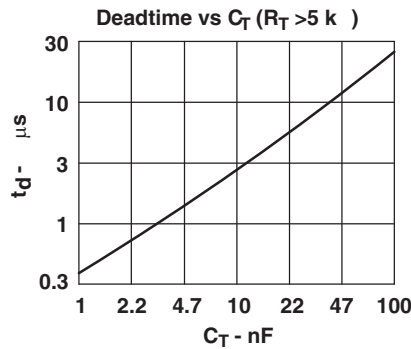

OUTPUT SATURATION CHARACTERISTICS

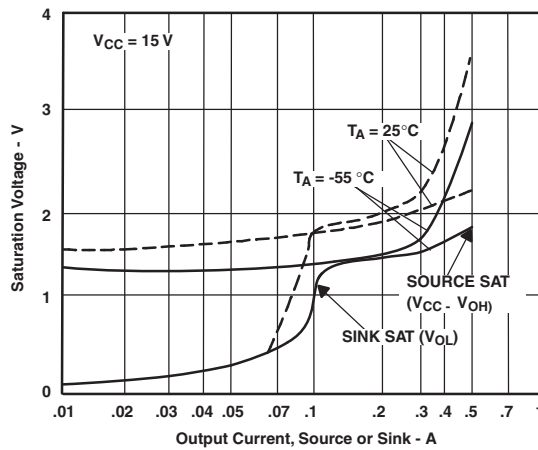

ERROR AMPLIFIER OPEN-LOOP FREQUENCY RESPONSE

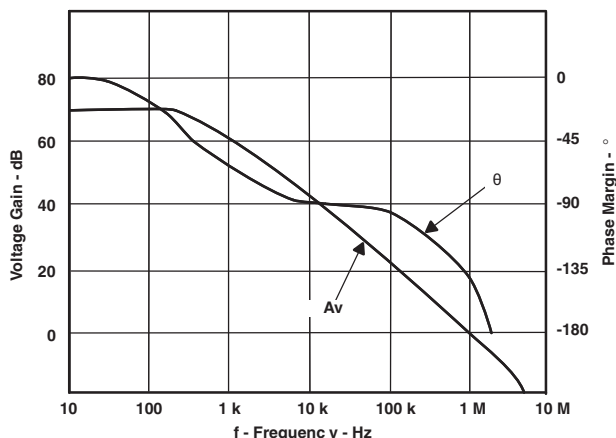

OPEN-LOOP LABORATORY FIXTURE

High peak currents associated with capacitive loads necessitate careful grounding techniques. Timing and bypass capacitors should be connected close to pin 5 in a single point ground. The transistor and 5k potentiometer are used to sample the oscillator waveform and apply an adjustable ramp to pin 3.

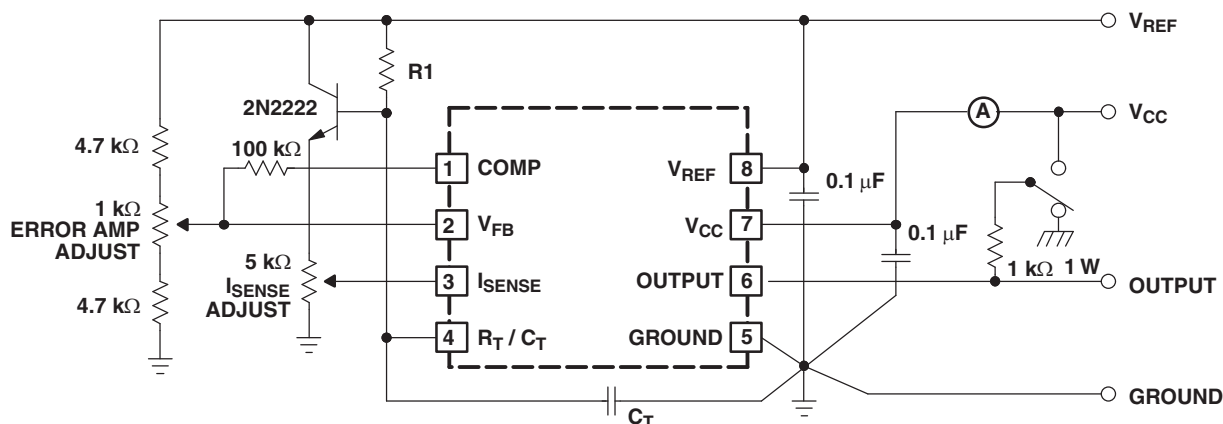

SHUTDOWN TECHNIQUES

Shutdown of the UC1843 can be accomplished by two methods; either raise pin 3 above 1 V or pull pin 1 below a voltage two diode drops above ground. Either method causes the output of the PWM comparator to be high (refer to block diagram). The PWM latch is reset dominant so that the output will remain low until the next clock cycle after the shutdown condition at pin 1 and/or 3 is removed. In one example, an externally latched shutdown may be accomplished by adding an SCR which will be reset by cycling V_{CC} below the lower UVLO threshold. At this point the reference turns off, allowing the SCR to reset.

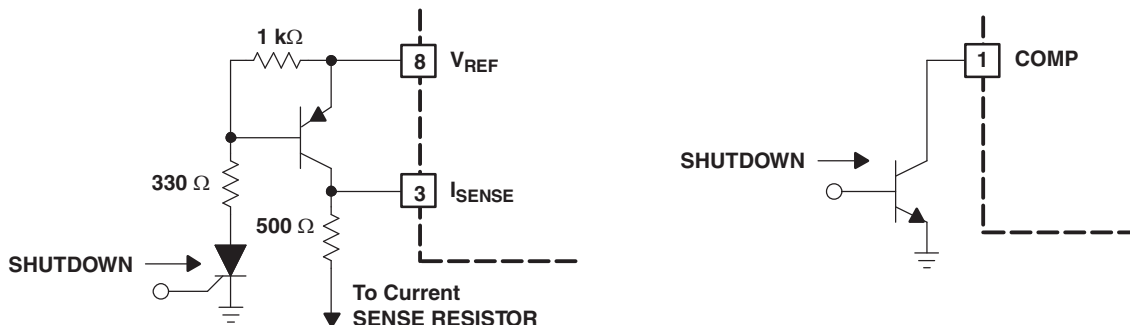

OFFLINE FLYBACK REGULATOR

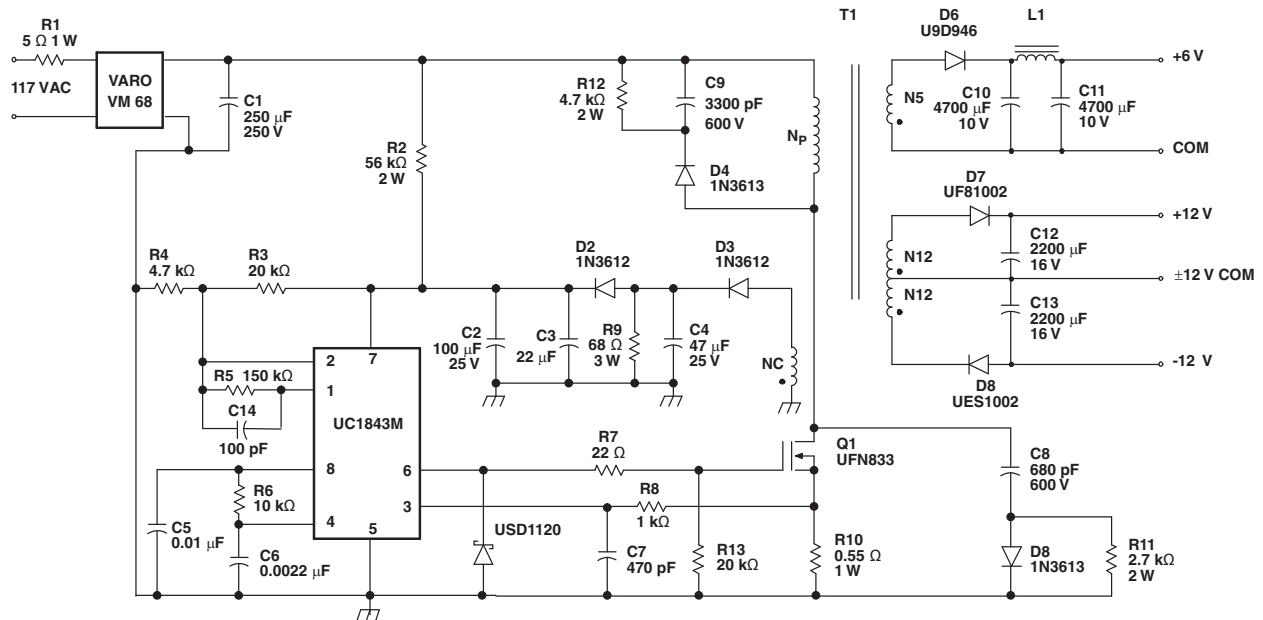

Power Supply Specifications

1. Input Voltages
 - a. 5VAC to 130VA (50 Hz/60 Hz)
2. Line Isolation: 3750 V
3. Switchng Frequency: 40 kHz
4. Efficiency at Full Load 70%
5. Output Voltage:
 - a. +5 V, $\pm 5\%$; 1A to 4A load
Ripple voltage: 50 mV P-P Max
 - b. +12 V, $\pm 3\%$; 0.1A to 0.3A load
Ripple voltage: 100 mV P-P Max
 - c. -12 V, $\pm 3\%$; 0.1A to 0.3A load
Ripple voltage: 100 mV P-P Max

SLOPE COMPENSATION

A fraction of the oscillator ramp can be resistively summed with the current sense signal to provide slope compensation for converters requiring duty cycles over 50%.

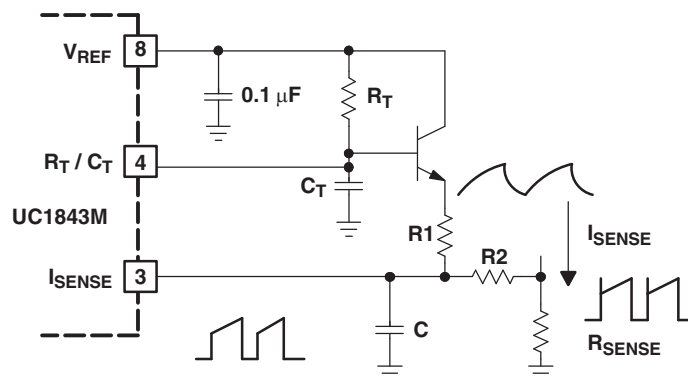

PACKAGING INFORMATION

Orderable Device	Status (1)	Package Type	Package Drawing	Pins	Package Qty	Eco Plan (2)	Lead/Ball Finish	MSL Peak Temp (3)	Op Temp (°C)	Top-Side Markings (4)	Samples
UC1843MKGD1	ACTIVE	XCEPT	KGD	0	100	TBD	Call TI	N / A for Pkg Type	-55 to 125		Samples

(1) The marketing status values are defined as follows:

ACTIVE: Product device recommended for new designs.

LIFEBUY: TI has announced that the device will be discontinued, and a lifetime-buy period is in effect.

NRND: Not recommended for new designs. Device is in production to support existing customers, but TI does not recommend using this part in a new design.

PREVIEW: Device has been announced but is not in production. Samples may or may not be available.

OBSELETE: TI has discontinued the production of the device.

(2) Eco Plan - The planned eco-friendly classification: Pb-Free (RoHS), Pb-Free (RoHS Exempt), or Green (RoHS & no Sb/Br) - please check <http://www.ti.com/productcontent> for the latest availability information and additional product content details.

TBD: The Pb-Free/Green conversion plan has not been defined.

Pb-Free (RoHS): TI's terms "Lead-Free" or "Pb-Free" mean semiconductor products that are compatible with the current RoHS requirements for all 6 substances, including the requirement that lead not exceed 0.1% by weight in homogeneous materials. Where designed to be soldered at high temperatures, TI Pb-Free products are suitable for use in specified lead-free processes.

Pb-Free (RoHS Exempt): This component has a RoHS exemption for either 1) lead-based flip-chip solder bumps used between the die and package, or 2) lead-based die adhesive used between the die and leadframe. The component is otherwise considered Pb-Free (RoHS compatible) as defined above.

Green (RoHS & no Sb/Br): TI defines "Green" to mean Pb-Free (RoHS compatible), and free of Bromine (Br) and Antimony (Sb) based flame retardants (Br or Sb do not exceed 0.1% by weight in homogeneous material)

(3) MSL, Peak Temp. -- The Moisture Sensitivity Level rating according to the JEDEC industry standard classifications, and peak solder temperature.

(4) Multiple Top-Side Markings will be inside parentheses. Only one Top-Side Marking contained in parentheses and separated by a "~" will appear on a device. If a line is indented then it is a continuation of the previous line and the two combined represent the entire Top-Side Marking for that device.

Important Information and Disclaimer:The information provided on this page represents TI's knowledge and belief as of the date that it is provided. TI bases its knowledge and belief on information provided by third parties, and makes no representation or warranty as to the accuracy of such information. Efforts are underway to better integrate information from third parties. TI has taken and continues to take reasonable steps to provide representative and accurate information but may not have conducted destructive testing or chemical analysis on incoming materials and chemicals. TI and TI suppliers consider certain information to be proprietary, and thus CAS numbers and other limited information may not be available for release.

In no event shall TI's liability arising out of such information exceed the total purchase price of the TI part(s) at issue in this document sold by TI to Customer on an annual basis.

IMPORTANT NOTICE

Texas Instruments Incorporated and its subsidiaries (TI) reserve the right to make corrections, enhancements, improvements and other changes to its semiconductor products and services per JESD46, latest issue, and to discontinue any product or service per JESD48, latest issue. Buyers should obtain the latest relevant information before placing orders and should verify that such information is current and complete. All semiconductor products (also referred to herein as "components") are sold subject to TI's terms and conditions of sale supplied at the time of order acknowledgment.

TI warrants performance of its components to the specifications applicable at the time of sale, in accordance with the warranty in TI's terms and conditions of sale of semiconductor products. Testing and other quality control techniques are used to the extent TI deems necessary to support this warranty. Except where mandated by applicable law, testing of all parameters of each component is not necessarily performed.

TI assumes no liability for applications assistance or the design of Buyers' products. Buyers are responsible for their products and applications using TI components. To minimize the risks associated with Buyers' products and applications, Buyers should provide adequate design and operating safeguards.

TI does not warrant or represent that any license, either express or implied, is granted under any patent right, copyright, mask work right, or other intellectual property right relating to any combination, machine, or process in which TI components or services are used. Information published by TI regarding third-party products or services does not constitute a license to use such products or services or a warranty or endorsement thereof. Use of such information may require a license from a third party under the patents or other intellectual property of the third party, or a license from TI under the patents or other intellectual property of TI.

Reproduction of significant portions of TI information in TI data books or data sheets is permissible only if reproduction is without alteration and is accompanied by all associated warranties, conditions, limitations, and notices. TI is not responsible or liable for such altered documentation. Information of third parties may be subject to additional restrictions.

Resale of TI components or services with statements different from or beyond the parameters stated by TI for that component or service voids all express and any implied warranties for the associated TI component or service and is an unfair and deceptive business practice. TI is not responsible or liable for any such statements.

Buyer acknowledges and agrees that it is solely responsible for compliance with all legal, regulatory and safety-related requirements concerning its products, and any use of TI components in its applications, notwithstanding any applications-related information or support that may be provided by TI. Buyer represents and agrees that it has all the necessary expertise to create and implement safeguards which anticipate dangerous consequences of failures, monitor failures and their consequences, lessen the likelihood of failures that might cause harm and take appropriate remedial actions. Buyer will fully indemnify TI and its representatives against any damages arising out of the use of any TI components in safety-critical applications.

In some cases, TI components may be promoted specifically to facilitate safety-related applications. With such components, TI's goal is to help enable customers to design and create their own end-product solutions that meet applicable functional safety standards and requirements. Nonetheless, such components are subject to these terms.

No TI components are authorized for use in FDA Class III (or similar life-critical medical equipment) unless authorized officers of the parties have executed a special agreement specifically governing such use.

Only those TI components which TI has specifically designated as military grade or "enhanced plastic" are designed and intended for use in military/aerospace applications or environments. Buyer acknowledges and agrees that any military or aerospace use of TI components which have **not** been so designated is solely at the Buyer's risk, and that Buyer is solely responsible for compliance with all legal and regulatory requirements in connection with such use.

TI has specifically designated certain components as meeting ISO/TS16949 requirements, mainly for automotive use. In any case of use of non-designated products, TI will not be responsible for any failure to meet ISO/TS16949.

Products

Audio	www.ti.com/audio
Amplifiers	amplifier.ti.com
Data Converters	dataconverter.ti.com
DLP® Products	www.dlp.com
DSP	dsp.ti.com
Clocks and Timers	www.ti.com/clocks
Interface	interface.ti.com
Logic	logic.ti.com
Power Mgmt	power.ti.com
Microcontrollers	microcontroller.ti.com
RFID	www.ti-rfid.com
OMAP Applications Processors	www.ti.com/omap
Wireless Connectivity	www.ti.com/wirelessconnectivity

Applications

Automotive and Transportation	www.ti.com/automotive
Communications and Telecom	www.ti.com/communications
Computers and Peripherals	www.ti.com/computers
Consumer Electronics	www.ti.com/consumer-apps
Energy and Lighting	www.ti.com/energy
Industrial	www.ti.com/industrial
Medical	www.ti.com/medical
Security	www.ti.com/security
Space, Avionics and Defense	www.ti.com/space-avionics-defense
Video and Imaging	www.ti.com/video

TI E2E Community

e2e.ti.com