

# ADS9120 16 位、2.5MSPS、15.5mW、SAR ADC，具有 multiSPI™ 接口

## 1 特性

- 采样率：2.5MSPS
- 无延迟输出
- 出色的直流和交流性能：
  - 积分非线性 (INL)：±0.25 最低有效位 (LSB) (典型值)，±0.6 LSB (最大值)
  - 微分非线性 (DNL)：±0.6 LSB (最大值)，16 位无丢码 (NMC)
  - 信噪比 (SNR)：96dB
  - 总谐波失真 (THD)：-118dB
- 宽输入范围：
  - 单极差分输入范围：±V<sub>REF</sub>
  - V<sub>REF</sub> 输入范围：2.5V 至 5V，与 AVDD 无关
- 低功耗：
  - 2.5MSPS 时为 9mW (仅限 AVDD)
  - 2.5MSPS 时为 15mW (总功耗)
  - 灵活的低功耗模式，可根据吞吐量调节功率
- multiSPI™：增强型串行接口
- 符合 JESD8-7A 标准的数字 I/O (1.8V DVDD 时)
- 在以下扩展级温度范围内完全额定运行：-40°C 至 +125°C
- 小型封装：4mm x 4mm 超薄四方扁平无引线 (VQFN) 封装

## 2 应用

- 测试和测量
- 电机控制
- 医疗成像
- 高精度、高速工业领域

## 3 说明

ADS9120 是一款 16 位、2.5MSPS、逐次逼近寄存器 (SAR) 模数转换器 (ADC)，在典型工作条件下具有 ±0.25 LSB INL 和 96 dB SNR 规范值。高吞吐量使得开发者能够对输入信号进行过采样，从而提高测量的动态范围和精度。

该器件支持单极全差分模拟输入信号，并采用 2.5V 至 5V 的外部基准电压，能够提供宽输入选择范围，无需额外进行输入调节。

该器件的功耗仅为 15.5mW (以 2.5MSPS 全吞吐量运行时)。吞吐量较低时，可灵活使用低功耗模式 (NAP 和 PD) 来降低功耗。

集成的 multiSPI™ 串行接口向后兼容传统 SPI 协议。此外，该器件的可配置特性还能够简化电路板布局、时序和固件，并且以低时钟速度运行时能够获得高吞吐量，因此可轻松连接各种微控制器、数字信号处理器 (DSP) 以及现场可编程门阵列 (FPGA)。

该器件采用节省空间的 4mm x 4mm VQFN 封装，支持符合 JESD8-7A 标准的 I/O 和扩展级工业温度范围。

### 器件信息

器件编号	封装	封装尺寸 (标称值)
ADS9120	VQFN (24)	4.00mm x 4.00mm

(1) 如需了解所有可用封装，请见数据表末尾的可订购产品附录。

典型应用图以及积分非线性与代码间的关系图

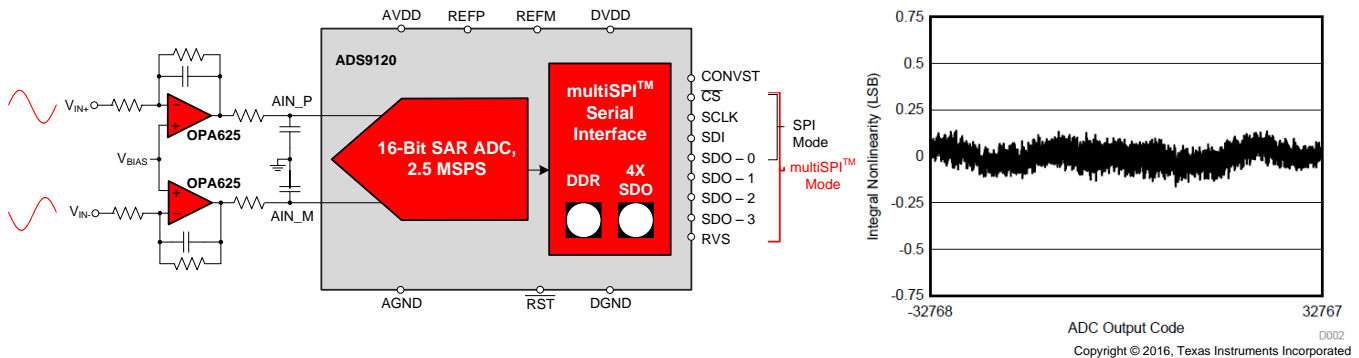

## 目录

<b>1</b>	特性 .....	<b>1</b>	7.2	Functional Block Diagram .....	<b>17</b>
<b>2</b>	应用 .....	<b>1</b>	7.3	Feature Description .....	<b>18</b>
<b>3</b>	说明 .....	<b>1</b>	7.4	Device Functional Modes .....	<b>22</b>
<b>4</b>	修订历史记录 .....	<b>2</b>	7.5	Programming .....	<b>24</b>
<b>5</b>	<b>Pin Configuration and Functions</b> .....	<b>3</b>	7.6	Register Maps .....	<b>44</b>
<b>6</b>	<b>Specifications</b> .....	<b>4</b>	<b>8</b>	<b>Application and Implementation</b> .....	<b>47</b>
6.1	Absolute Maximum Ratings .....	<b>4</b>	8.1	Application Information .....	<b>47</b>
6.2	ESD Ratings .....	<b>4</b>	8.2	Typical Application .....	<b>50</b>
6.3	Recommended Operating Conditions .....	<b>4</b>	<b>9</b>	<b>Power-Supply Recommendations</b> .....	<b>52</b>
6.4	Thermal Information .....	<b>4</b>	9.1	Power-Supply Decoupling .....	<b>52</b>
6.5	Electrical Characteristics .....	<b>5</b>	9.2	Power Saving .....	<b>52</b>
6.6	Timing Requirements: Conversion Cycle .....	<b>7</b>	<b>10</b>	<b>Layout</b> .....	<b>54</b>
6.7	Timing Requirements: Asynchronous Reset, NAP, and PD .....	<b>7</b>	10.1	Layout Guidelines .....	<b>54</b>
6.8	Timing Requirements: SPI-Compatible Serial Interface .....	<b>7</b>	10.2	Layout Example .....	<b>55</b>
6.9	Timing Requirements: Source-Synchronous Serial Interface (External Clock) .....	<b>8</b>	<b>11</b>	<b>器件和文档支持</b> .....	<b>56</b>
6.10	Timing Requirements: Source-Synchronous Serial Interface (Internal Clock) .....	<b>8</b>	11.1	文档支持 .....	<b>56</b>
6.11	Typical Characteristics .....	<b>12</b>	11.2	接收文档更新通知 .....	<b>56</b>
<b>7</b>	<b>Detailed Description</b> .....	<b>17</b>	11.3	社区资源 .....	<b>56</b>
7.1	Overview .....	<b>17</b>	11.4	商标 .....	<b>56</b>
			11.5	静电放电警告 .....	<b>56</b>
			11.6	Glossary .....	<b>56</b>
			<b>12</b>	<b>机械、封装和可订购信息</b> .....	<b>56</b>

## 4 修订历史记录

日期	修订版本	注释
2016 年 9 月	*	最初发布。

## 5 Pin Configuration and Functions

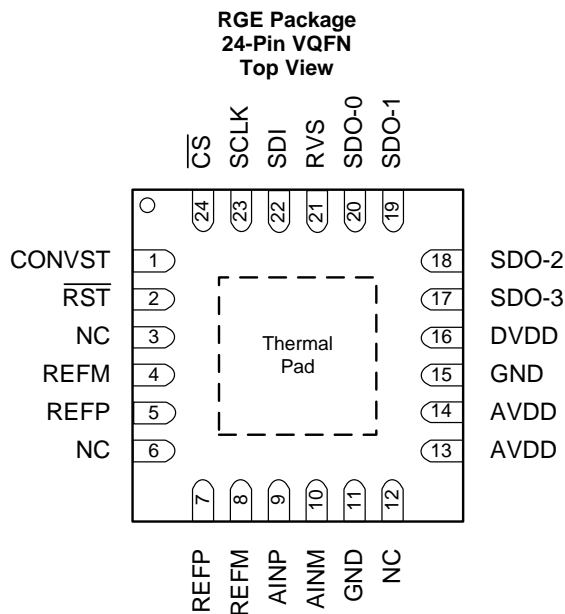

### Pin Functions

PIN		FUNCTION	DESCRIPTION
NAME	NO.		
AINM	10	Analog input	Negative analog input
AINP	9	Analog input	Positive analog input
AVDD	13, 14	Power supply	Analog power supply for the device
CONVST	1	Digital input	Conversion start input pin for the device. A CONVST rising edge brings the device from ACQ state to CNV state.
$\overline{CS}$	24	Digital input	Chip-select input pin for the device; active low. The device takes control of the data bus when $\overline{CS}$ is low. The SDO-x pins go to tri-state when $\overline{CS}$ is high.
DVDD	16	Power supply	Interface supply
GND	11, 15	Power supply	Ground
NC	3, 6, 12	No connection	These pins must be left floating with no external connection
REFM	4, 8	Analog input	Reference ground potential
REFP	5, 7	Analog input	Reference voltage input
$\overline{RST}$	2	Digital input	Asynchronous reset input pin for the device. A low pulse on the $\overline{RST}$ pin resets the device and all register bits return to a default state.
RVS	21	Digital output	Multi-function output pin for the device. With $\overline{CS}$ held high, RVS reflects the status of the internal ADCST signal. With $\overline{CS}$ low, the status of RVS depends on the output protocol selection.
SCLK	23	Digital input	Clock input pin for the serial interface. All system-synchronous data transfer protocols are timed with respect to the SCLK signal.
SDI	22	Digital input	Serial data input pin for the device. This pin is used to feed the data or command into the device.
SDO-0	20	Digital output	Serial communication: data output 0
SDO-1	19	Digital output	Serial communication: data output 1
SDO-2	18	Digital output	Serial communication: data output 2
SDO-3	17	Digital output	Serial communication: data output 3
Thermal pad		Supply	Exposed thermal pad; connecting this pin to GND is recommended

## 6 Specifications

### 6.1 Absolute Maximum Ratings

over operating free-air temperature range (unless otherwise noted)<sup>(1)</sup>

	MIN	MAX	UNIT
AVDD to GND	-0.3	2.1	V
DVDD to GND	-0.3	2.1	V
REFP to REFM	-0.3	5.5	V
REFM to GND	-0.1	0.1	V
Analog (AINP, AINM) to GND	-0.3	REFP + 0.3	V
Digital input ( $\overline{\text{RST}}$ , CONVST, $\overline{\text{CS}}$ , SCLK, SDI) to GND	-0.3	DVDD + 0.3	V
Digital output (RVS, SDO-0, SDO-1, SDO-2, SDO-3) to GND	-0.3	DVDD + 0.3	V
Operating temperature, $T_A$	-40	125	°C
Storage temperature, $T_{\text{stg}}$	-65	150	°C

- (1) Stresses beyond those listed under *Absolute Maximum Ratings* may cause permanent damage to the device. These are stress ratings only, which do not imply functional operation of the device at these or any other conditions beyond those indicated under *Recommended Operating Conditions*. Exposure to absolute-maximum-rated conditions for extended periods may affect device reliability.

### 6.2 ESD Ratings

		VALUE	UNIT
$V_{\text{(ESD)}}$ Electrostatic discharge	Human-body model (HBM), per ANSI/ESDA/JEDEC JS-001 <sup>(1)</sup>	±2000	V
	Charged-device model (CDM), per JEDEC specification JESD22-C101 <sup>(2)</sup>	±500	

- (1) JEDEC document JEP155 states that 500-V HBM allows safe manufacturing with a standard ESD control process.  
 (2) JEDEC document JEP157 states that 250-V CDM allows safe manufacturing with a standard ESD control process.

### 6.3 Recommended Operating Conditions

over operating free-air temperature range (unless otherwise noted)

	MIN	NOM	MAX	UNIT
AVDD Analog supply voltage		1.8		V
DVDD Digital supply voltage		1.8		V
REFP Positive reference		5		V

### 6.4 Thermal Information

THERMAL METRIC <sup>(1)</sup>		ADS9120	UNITS
		RGE (VQFN)	
		24 PINS	
$R_{\theta\text{JA}}$	Junction-to-ambient thermal resistance	31.9	°C/W
$R_{\theta\text{JC(top)}}$	Junction-to-case (top) thermal resistance	29.9	°C/W
$R_{\theta\text{JB}}$	Junction-to-board thermal resistance	8.9	°C/W
$\Psi_{\text{JT}}$	Junction-to-top characterization parameter	0.3	°C/W
$\Psi_{\text{JB}}$	Junction-to-board characterization parameter	8.9	°C/W
$R_{\theta\text{JC(bot)}}$	Junction-to-case (bottom) thermal resistance	2.0	°C/W

- (1) For more information about traditional and new thermal metrics, see the [Semiconductor and IC Package Thermal Metrics](#) application report.

## 6.5 Electrical Characteristics

All specifications are for AVDD = 1.8 V, DVDD = 1.8 V, VREF = 5 V, and fDATA = 2.5 MSPS, unless otherwise noted.

All minimum and maximum specifications are for TA = -40°C to +125°C, unless otherwise noted.

All typical values are at TA = 25°C.

PARAMETER		TEST CONDITIONS	MIN	TYP	MAX	UNIT
<b>ANALOG INPUT</b>						
FSR	Full-scale input range (AINP – AINM) <sup>(1)</sup>		-VREF		VREF	V
VIN	Absolute input voltage (AINP and AINM to REFGND)		-0.1		VREF + 0.1	V
VCM	Common-mode voltage range (AINP + AINM) / 2		(VREF / 2) – 0.1	VREF / 2	(VREF / 2) + 0.1	V
CIN	Input capacitance	In sample mode		60		pF
		In hold mode		4		
IIL	Input leakage current			±1		µA
<b>VOLTAGE REFERENCE INPUT</b>						
VREF	Reference input voltage range		2.5		5	V
IREF	Reference input current	Average current, VREF = 5 V, 2-kHz, full-scale input, throughput = 2.5 MSPS		1.3		mA
<b>DC ACCURACY</b>						
	Resolution			16		Bits
NMC	No missing codes		16			Bits
INL	Integral nonlinearity	TA = -40°C to +85°C	-0.6	±0.25 <sup>(2)</sup>	0.6	LSB <sup>(3)</sup>
		TA = -40°C to +125°C	-0.7	±0.25 <sup>(2)</sup>	0.7	
DNL	Differential nonlinearity	TA = -40°C to +85°C	-0.6	±0.25 <sup>(2)</sup>	0.6	LSB
		TA = -40°C to +125°C	-0.7	±0.25 <sup>(2)</sup>	0.7	
E(IO)	Input offset error		-1	±0.025 <sup>(2)</sup>	1	mV
dVOS/dT	Input offset thermal drift			1		µV/°C
GE	Gain error		-0.02	±0.01 <sup>(2)</sup>	0.02	%FS
GE/dT	Gain error thermal drift			0.25		ppm/°C
	Transition noise			0.35		LSB
CMRR	Common-mode rejection ratio	At dc to 20 kHz		80		dB

(1) Ideal input span, does not include gain or offset errors.

(2) See Figure 9, Figure 10, Figure 25, and Figure 26 for statistical distribution data for INL, DNL, offset, and gain error parameters.

(3) LSB = least-significant bit. 1 LSB at 18 bits is approximately 3.8 ppm.

**Electrical Characteristics (continued)**

All specifications are for AVDD = 1.8 V, DVDD = 1.8 V, V<sub>REF</sub> = 5 V, and f<sub>DATA</sub> = 2.5 MSPS, unless otherwise noted.

All minimum and maximum specifications are for T<sub>A</sub> = -40°C to +125°C, unless otherwise noted.

All typical values are at T<sub>A</sub> = 25°C.

PARAMETER		TEST CONDITIONS	MIN	TYP	MAX	UNIT
<b>AC ACCURACY<sup>(4)</sup></b>						
SINAD	Signal-to-noise + distortion	f <sub>IN</sub> = 2 kHz	94.4	96		dB
		f <sub>IN</sub> = 100 kHz		95		
		f <sub>IN</sub> = 500 kHz		83.9		
SNR	Signal-to-noise ratio	f <sub>IN</sub> = 2 kHz	94.5	96		dB
		f <sub>IN</sub> = 100 kHz		95.9		
		f <sub>IN</sub> = 500 kHz		84		
THD	Total harmonic distortion <sup>(5)</sup>	f <sub>IN</sub> = 2 kHz		-118		dB
		f <sub>IN</sub> = 100 kHz		-102		
		f <sub>IN</sub> = 500 kHz		-101		
SFDR	Spurious-free dynamic range	f <sub>IN</sub> = 2 kHz		120		dB
		f <sub>IN</sub> = 100 kHz		108		
		f <sub>IN</sub> = 500 kHz		106		
<b>DIGITAL INPUTS<sup>(6)</sup></b>						
V <sub>IH</sub>	High-level input voltage		0.65 DVDD		DVDD + 0.3	V
V <sub>IL</sub>	Low-level input voltage		-0.3		0.35 DVDD	V
<b>DIGITAL OUTPUTS<sup>(6)</sup></b>						
V <sub>OH</sub>	High-level output voltage	I <sub>OH</sub> = 2-mA source	DVDD - 0.45			V
V <sub>OL</sub>	Low-level output voltage	I <sub>OH</sub> = 2-mA sink			0.45	V
<b>POWER SUPPLY</b>						
AVDD	Analog supply voltage		1.65	1.8	1.95	V
DVDD	Digital supply voltage		1.65	1.8	1.95	V
I <sub>DD</sub>	AVDD supply current (AVDD = 1.8 V)	Active, 2.5-MSPS throughput, T <sub>A</sub> = -40°C to +85°C		5	6.5	mA
		Active, 2.5-MSPS throughput, T <sub>A</sub> = -40°C to +125°C		5	6.75	
		Static, ACQ state		3.7		mA
		Low-power, NAP mode		500		μA
		Power-down, PD state		1		
P <sub>D</sub>	AVDD power dissipation (AVDD = 1.8 V)	Active, 2.5-MSPS throughput, T <sub>A</sub> = -40°C to +85°C		9	11.7	mW
		Active, 2.5-MSPS throughput, T <sub>A</sub> = -40°C to +125°C		9	12.15	
		Static, ACQ state		6.6		mW
		Low-power, NAP mode		900		μW
		Power-down, PD state		1.8		
<b>TEMPERATURE RANGE</b>						
T <sub>A</sub>	Operating free-air temperature		-40		125	°C

(4) All specifications expressed in decibels (dB) refer to the full-scale input (FSR) and are tested with an input signal 0.1 dB below full-scale, unless otherwise specified.

(5) Calculated on the first nine harmonics of the input frequency.

(6) As per the JESD8-7A standard. Specified by design; not production tested.

## 6.6 Timing Requirements: Conversion Cycle

All specifications are for AVDD = 1.8 V, DVDD = 1.8 V, V<sub>REF</sub> = 5 V, and f<sub>DATA</sub> = 2.5 MSPS, unless otherwise noted.

All minimum and maximum specifications are for T<sub>A</sub> = -40°C to +125°C. All typical values are at T<sub>A</sub> = 25°C. See [Figure 1](#).

		MIN	TYP	MAX	UNIT
<b>TIMING REQUIREMENTS</b>					
f <sub>cycle</sub>	Sampling frequency			2.5	MHz
t <sub>cycle</sub>	ADC cycle time period	400			ns
t <sub>wh_CONVST</sub>	Pulse duration: CONVST high	30			ns
t <sub>wl_CONVST</sub>	Pulse duration: CONVST low	30			ns
t <sub>acq</sub>	Acquisition time	100			ns
t <sub>qt_acq</sub>	Quiet acquisition time <sup>(1)</sup>	25			ns
t <sub>d_cnvcap</sub>	Quiet aperture time <sup>(1)</sup>	10			ns
<b>TIMING SPECIFICATIONS</b>					
t <sub>conv</sub>	Conversion time	270		290	ns

(1) See [Figure 47](#).

## 6.7 Timing Requirements: Asynchronous Reset, NAP, and PD

All specifications are for AVDD = 1.8 V, DVDD = 1.8 V, V<sub>REF</sub> = 5 V, and f<sub>DATA</sub> = 2.5 MSPS, unless otherwise noted.

All minimum and maximum specifications are for T<sub>A</sub> = -40°C to +125°C. All typical values are at T<sub>A</sub> = 25°C. See [Figure 2](#) and

[Figure 3](#).

		MIN	TYP	MAX	UNIT
<b>TIMING REQUIREMENTS</b>					
t <sub>wl_RST</sub>	Pulse duration: $\overline{\text{RST}}$ low	100			ns
<b>TIMING SPECIFICATIONS</b>					
t <sub>d_rst</sub>	Delay time: $\overline{\text{RST}}$ rising to RVS rising			1250	μs
t <sub>nap_wkup</sub>	Wake-up time: NAP mode			300	ns
t <sub>PWRUP</sub>	Power-up time: PD mode			250	μs

## 6.8 Timing Requirements: SPI-Compatible Serial Interface

All specifications are for AVDD = 1.8 V, DVDD = 1.8 V, V<sub>REF</sub> = 5 V, and f<sub>DATA</sub> = 2.5 MSPS, unless otherwise noted.

All minimum and maximum specifications are for T<sub>A</sub> = -40°C to +125°C. All typical values are at T<sub>A</sub> = 25°C. See [Figure 4](#).

		MIN	TYP	MAX	UNIT
<b>TIMING REQUIREMENTS</b>					
f <sub>CLK</sub>	Serial clock frequency			75	MHz
t <sub>CLK</sub>	Serial clock time period	13.33			ns
t <sub>ph_CK</sub>	SCLK high time	0.45		0.55	t <sub>CLK</sub>
t <sub>pl_CK</sub>	SCLK low time	0.45		0.55	t <sub>CLK</sub>
t <sub>su_CSCK</sub>	Setup time: $\overline{\text{CS}}$ falling to the first SCLK capture edge	5			ns
t <sub>su_CKDI</sub>	Setup time: SDI data valid to the SCLK capture edge	1.2			ns
t <sub>ht_CKDI</sub>	Hold time: SCLK capture edge to (previous) data valid on SDI	0.65			ns
t <sub>ht_CKCS</sub>	Delay time: last SCLK falling to $\overline{\text{CS}}$ rising	5			ns
<b>TIMING SPECIFICATIONS</b>					
t <sub>den_CSDO</sub>	Delay time: $\overline{\text{CS}}$ falling to data enable			4.5	ns
t <sub>dz_CSDO</sub>	Delay time: $\overline{\text{CS}}$ rising to SDO going to 3-state			10	ns
t <sub>d_CKDO</sub>	Delay time: SCLK launch edge to (next) data valid on SDO			6.5	ns
t <sub>d_CSRDY_f</sub>	Delay time: $\overline{\text{CS}}$ falling to RVS falling			5	ns
t <sub>d_CSRDY_r</sub>	Delay time: CS rising to RVS rising	After NOP operation		10	ns
		After WR or RD operation		70	

## 6.9 Timing Requirements: Source-Synchronous Serial Interface (External Clock)

All specifications are for AVDD = 1.8 V, DVDD = 1.8 V, V<sub>REF</sub> = 5 V, and f<sub>DATA</sub> = 2.5 MSPS, unless otherwise noted.

All minimum and maximum specifications are for T<sub>A</sub> = -40°C to +125°C. All typical values are at T<sub>A</sub> = 25°C. See [Figure 5](#).

		MIN	TYP	MAX	UNIT
<b>TIMING REQUIREMENTS</b>					
f <sub>CLK</sub>	Serial clock frequency			100	MHz
t <sub>CLK</sub>	Serial clock time period	10			ns
<b>TIMING SPECIFICATIONS<sup>(1)</sup></b>					
t <sub>d_CKSTR_r</sub>	Delay time: SCLK launch edge to RVS rising			8.5	ns
t <sub>d_CKSTR_f</sub>	Delay time: SCLK launch edge to RVS falling			8.5	ns
t <sub>off_STRDO_f</sub>	Time offset: RVS rising to (next) data valid on SDO	-0.5		0.5	ns
t <sub>off_STRDO_r</sub>	Time offset: RVS falling to (next) data valid on SDO	-0.5		0.5	ns

(1) Other parameters are the same as the [Timing Requirements: SPI-Compatible Serial Interface](#) table.

## 6.10 Timing Requirements: Source-Synchronous Serial Interface (Internal Clock)

All specifications are for AVDD = 1.8 V, DVDD = 1.8 V, V<sub>REF</sub> = 5 V, and f<sub>DATA</sub> = 2.5 MSPS, unless otherwise noted.

All minimum and maximum specifications are for T<sub>A</sub> = -40°C to +125°C. All typical values are at T<sub>A</sub> = 25°C. See [Figure 6](#).

		MIN	TYP	MAX	UNIT
<b>TIMING SPECIFICATIONS<sup>(1)</sup></b>					
t <sub>d_CSSTR</sub>	Delay time: $\overline{CS}$ falling to RVS rising	12		40	ns
t <sub>off_STRDO_f</sub>	Time offset: RVS rising to (next) data valid on SDO	-0.5		0.5	ns
t <sub>off_STRDO_r</sub>	Time offset: RVS falling to (next) data valid on SDO	-0.5		0.5	ns
t <sub>STR</sub>	Strobe output time period	INTCLK option		11.1	ns
		INTCLK / 2 option	19.8	22.2	
		INTCLK / 4 option	39.6	44.4	
t <sub>ph_STR</sub>	Strobe output high time	0.45		0.55	t <sub>STR</sub>
t <sub>pl_STR</sub>	Strobe output low time	0.45		0.55	t <sub>STR</sub>

(1) Other parameters are the same as the [Timing Requirements: SPI-Compatible Serial Interface](#) table.



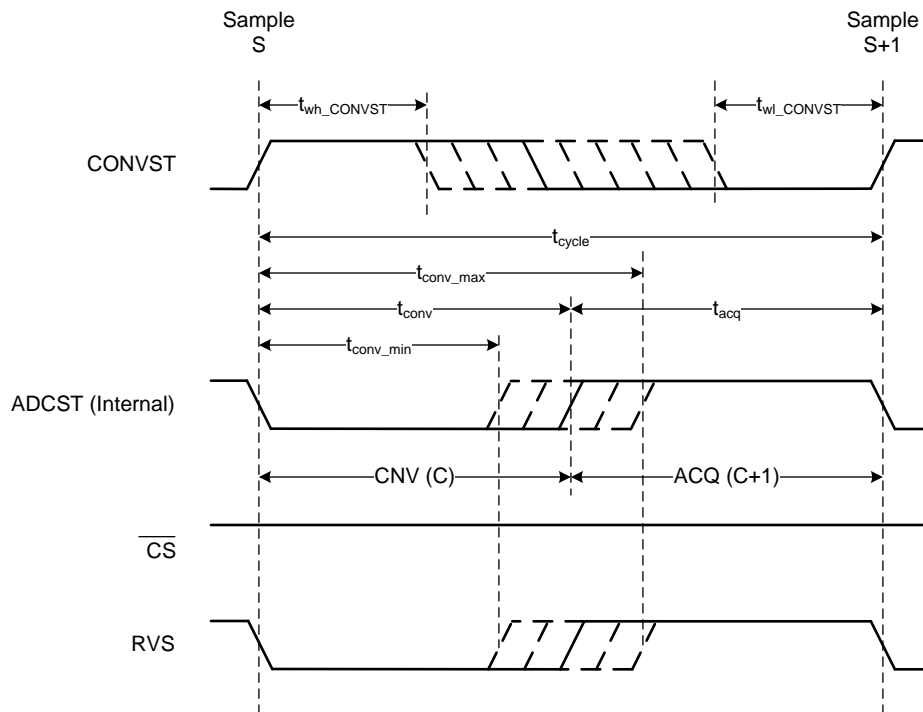

Figure 1. Conversion Cycle Timing Diagram

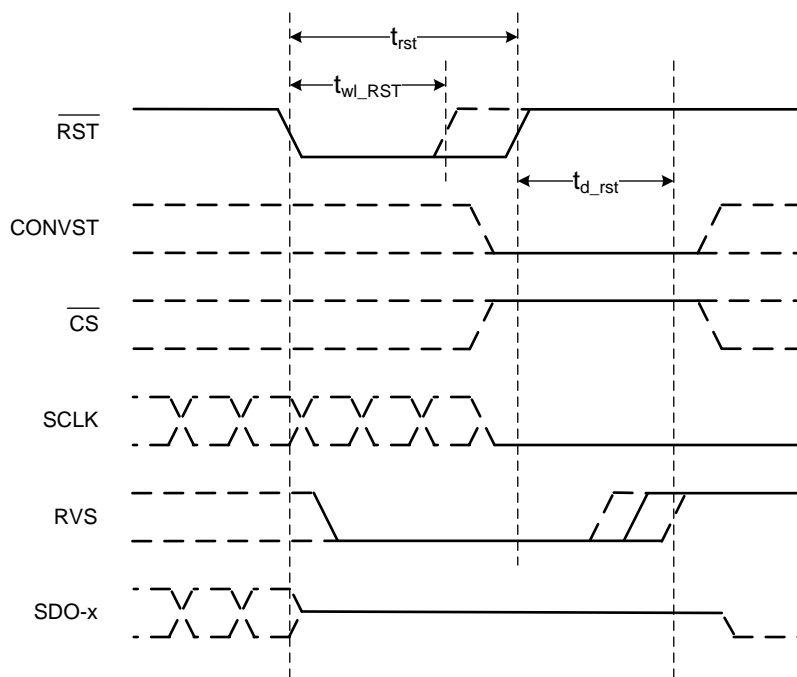

Figure 2. Asynchronous Reset Timing Diagram

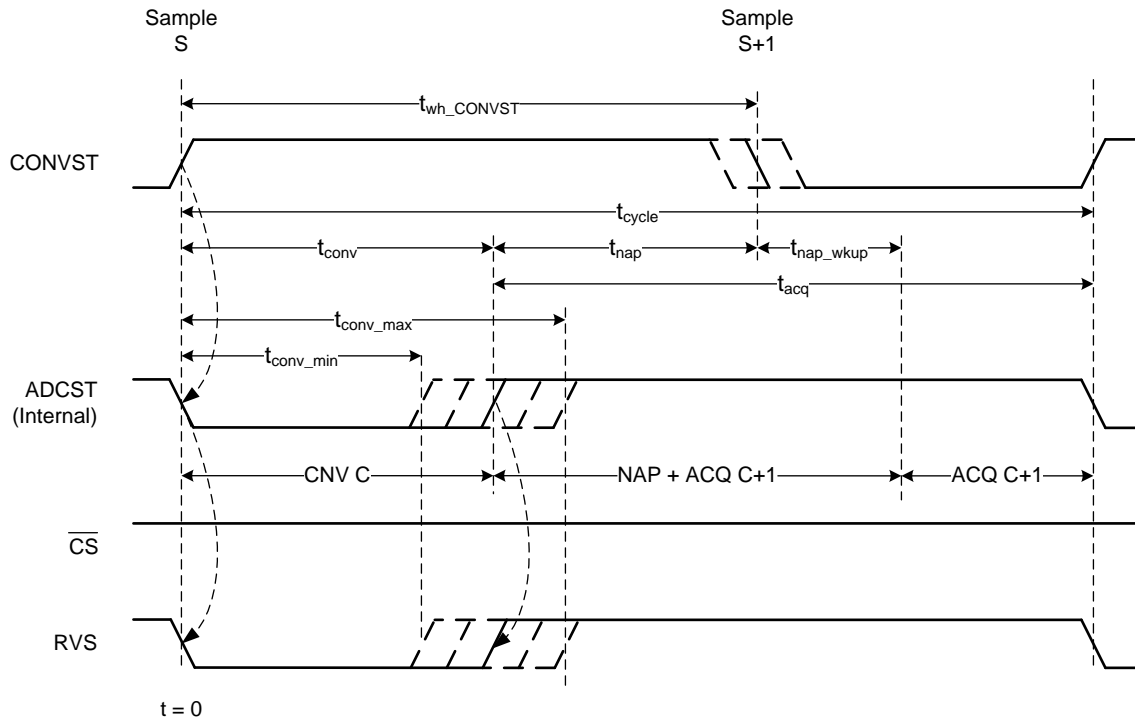
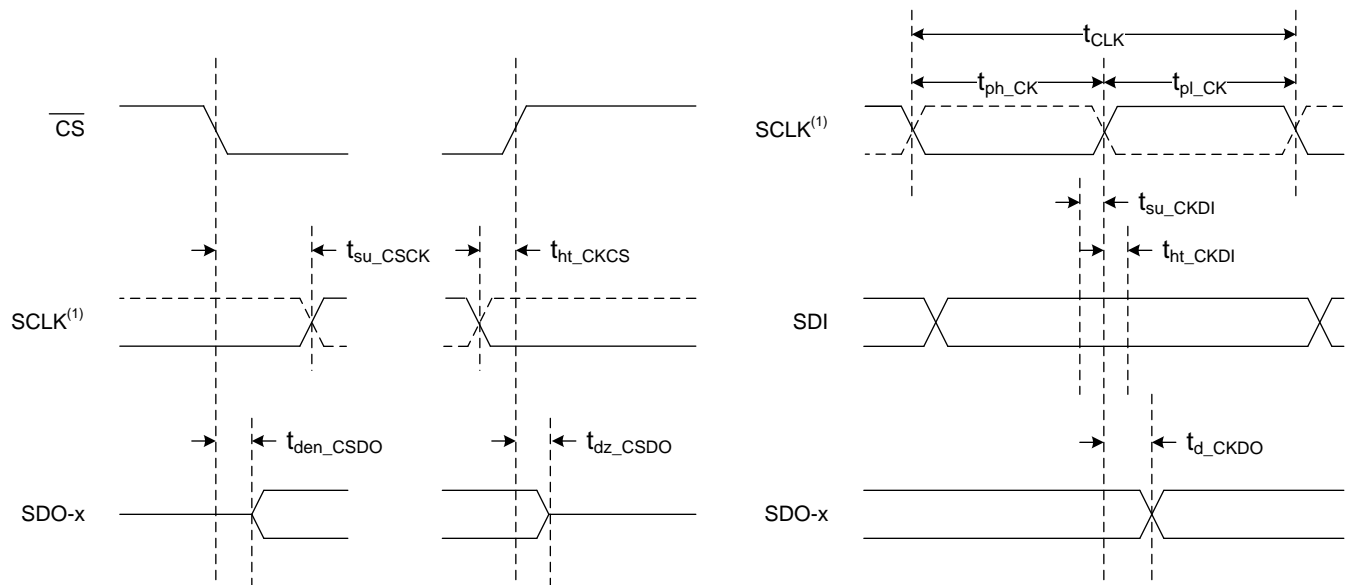

Figure 3. NAP Mode Timing Diagram



(1) The SCLK polarity, launch edge, and capture edge depend on the SPI protocol selected.

Figure 4. SPI-Compatible Serial Interface Timing Diagram

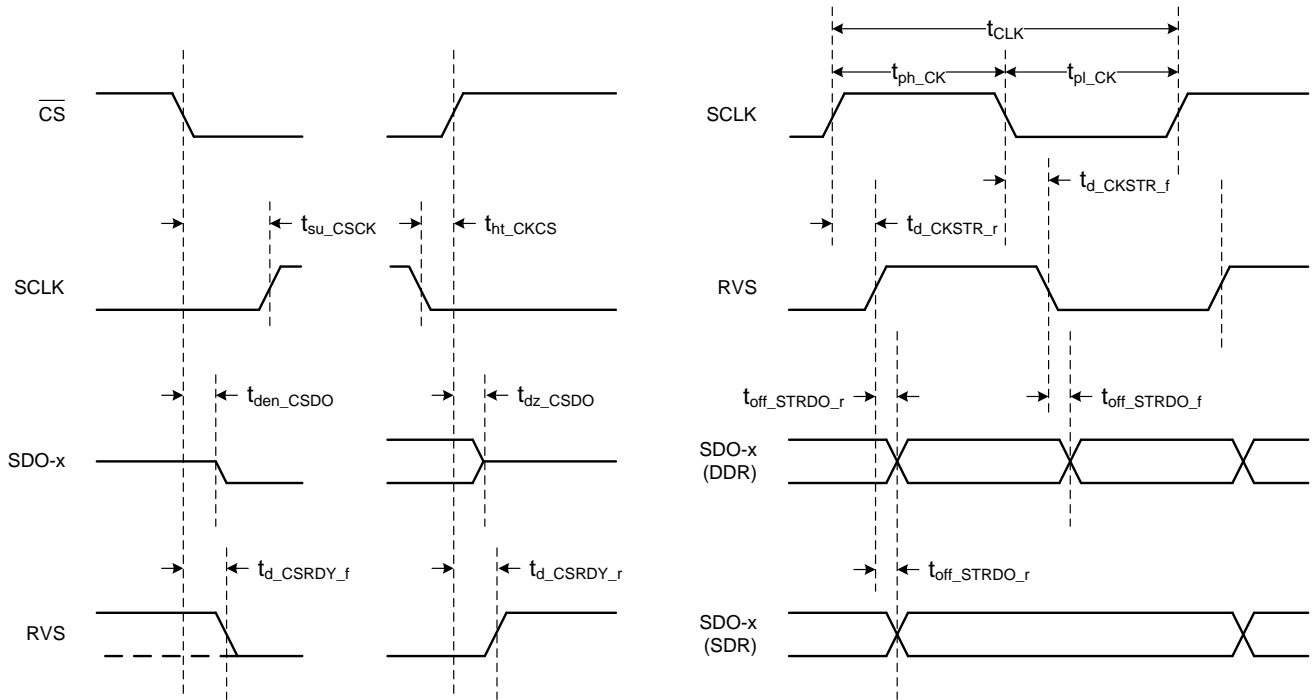

Figure 5. Source-Synchronous Serial Interface Timing Diagram (External Clock)

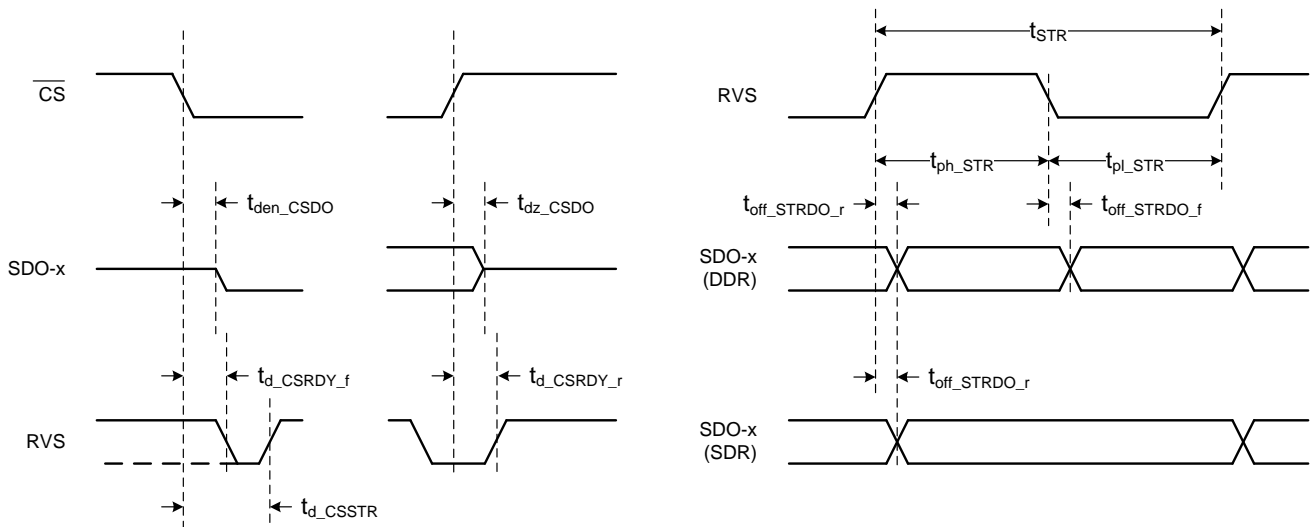
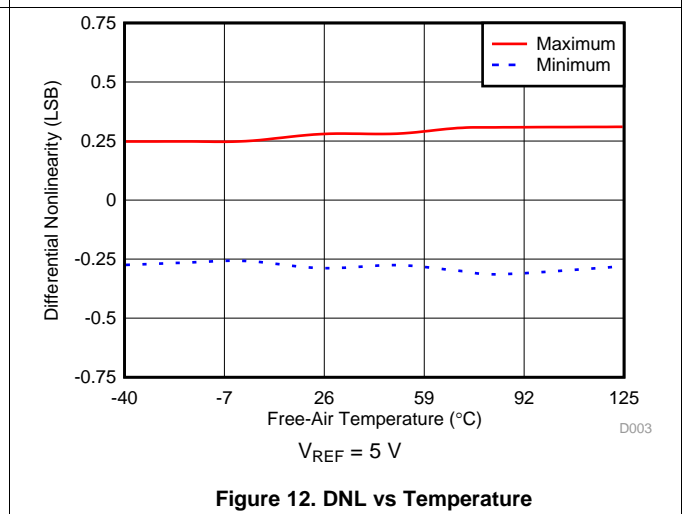
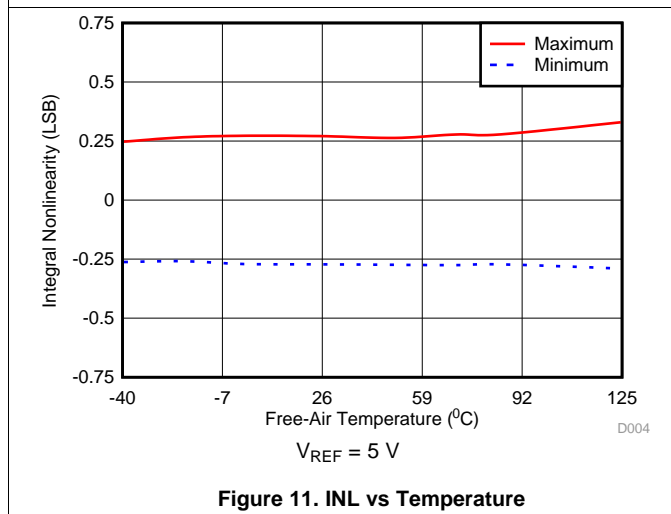
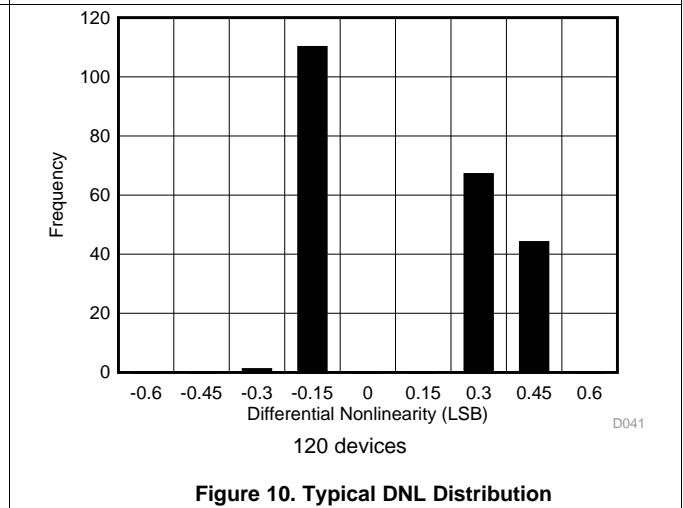
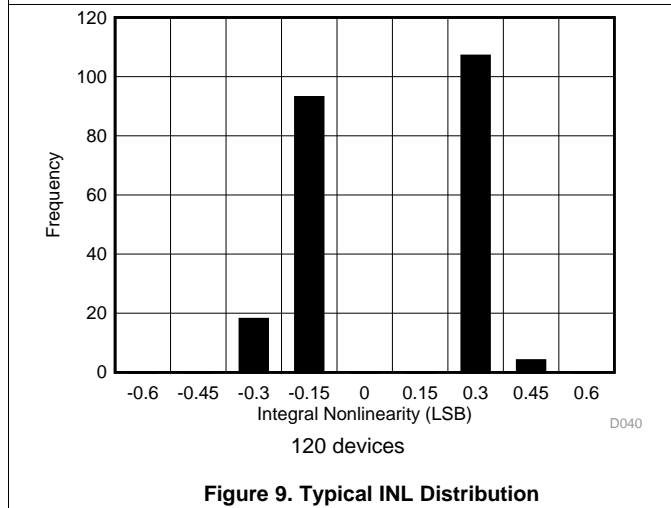
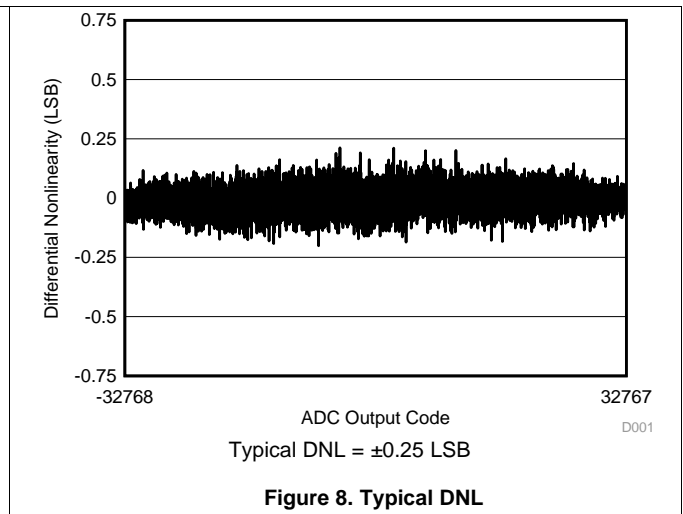
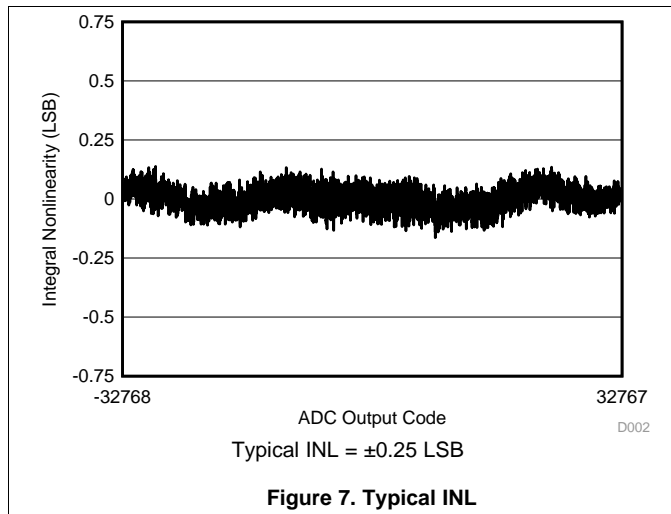

Figure 6. Source-Synchronous Serial Interface Timing Diagram (Internal Clock)

### 6.11 Typical Characteristics

at  $T_A = 25^\circ\text{C}$ ,  $AVDD = 1.8\text{ V}$ ,  $DVDD = 1.8\text{ V}$ ,  $V_{REF} = 5\text{ V}$ , and  $f_{SAMPLE} = 2.5\text{ MSPS}$  (unless otherwise noted)



Typical Characteristics (continued)

at  $T_A = 25^\circ\text{C}$ ,  $AVDD = 1.8\text{ V}$ ,  $DVDD = 1.8\text{ V}$ ,  $V_{REF} = 5\text{ V}$ , and  $f_{SAMPLE} = 2.5\text{ MSPS}$  (unless otherwise noted)

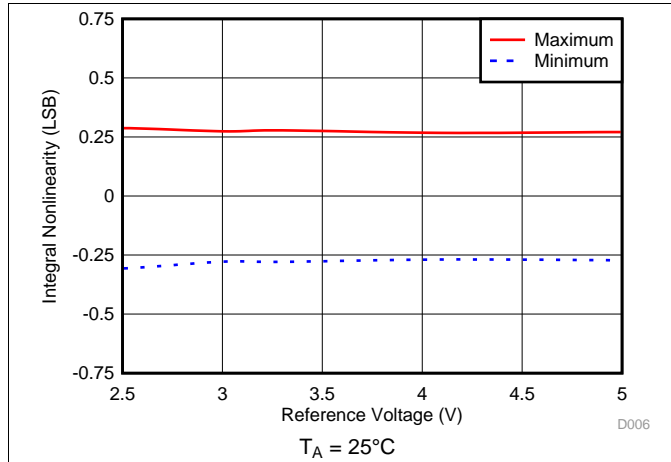

Figure 13. INL vs Reference Voltage

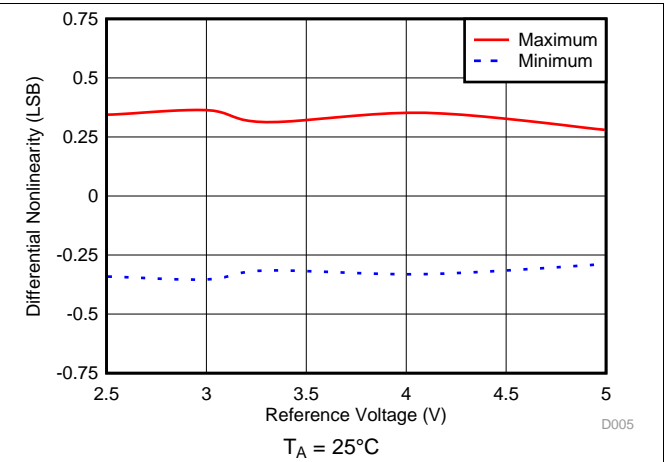

Figure 14. DNL vs Reference Voltage

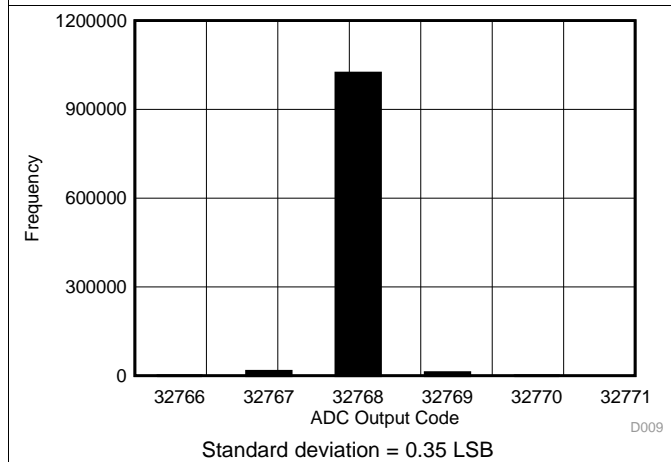

Figure 15. DC Input Histogram, Code Center

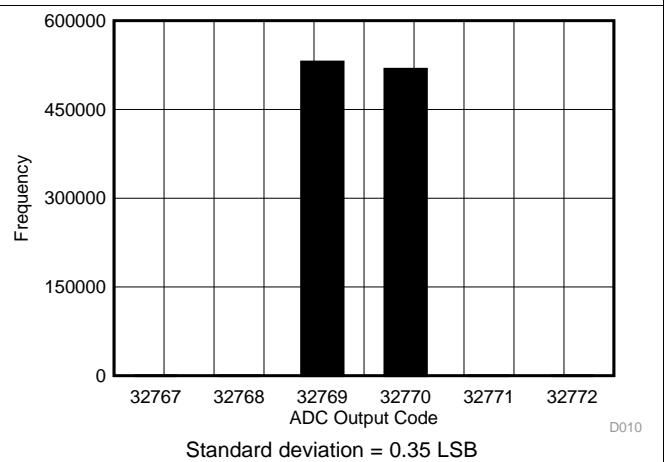

Figure 16. DC Input Histogram, Code Transition

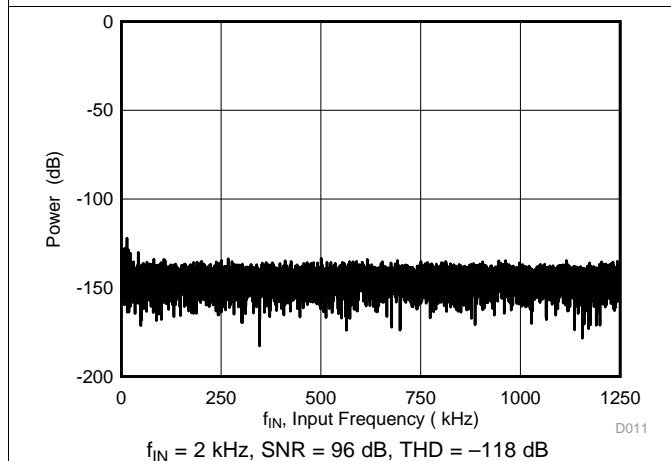

Figure 17. Typical FFT

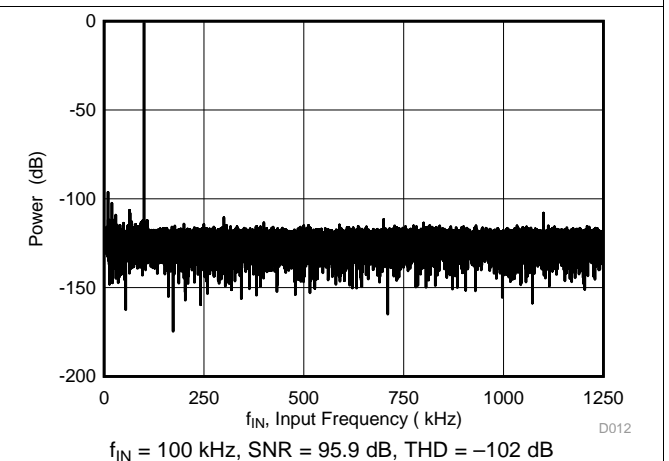
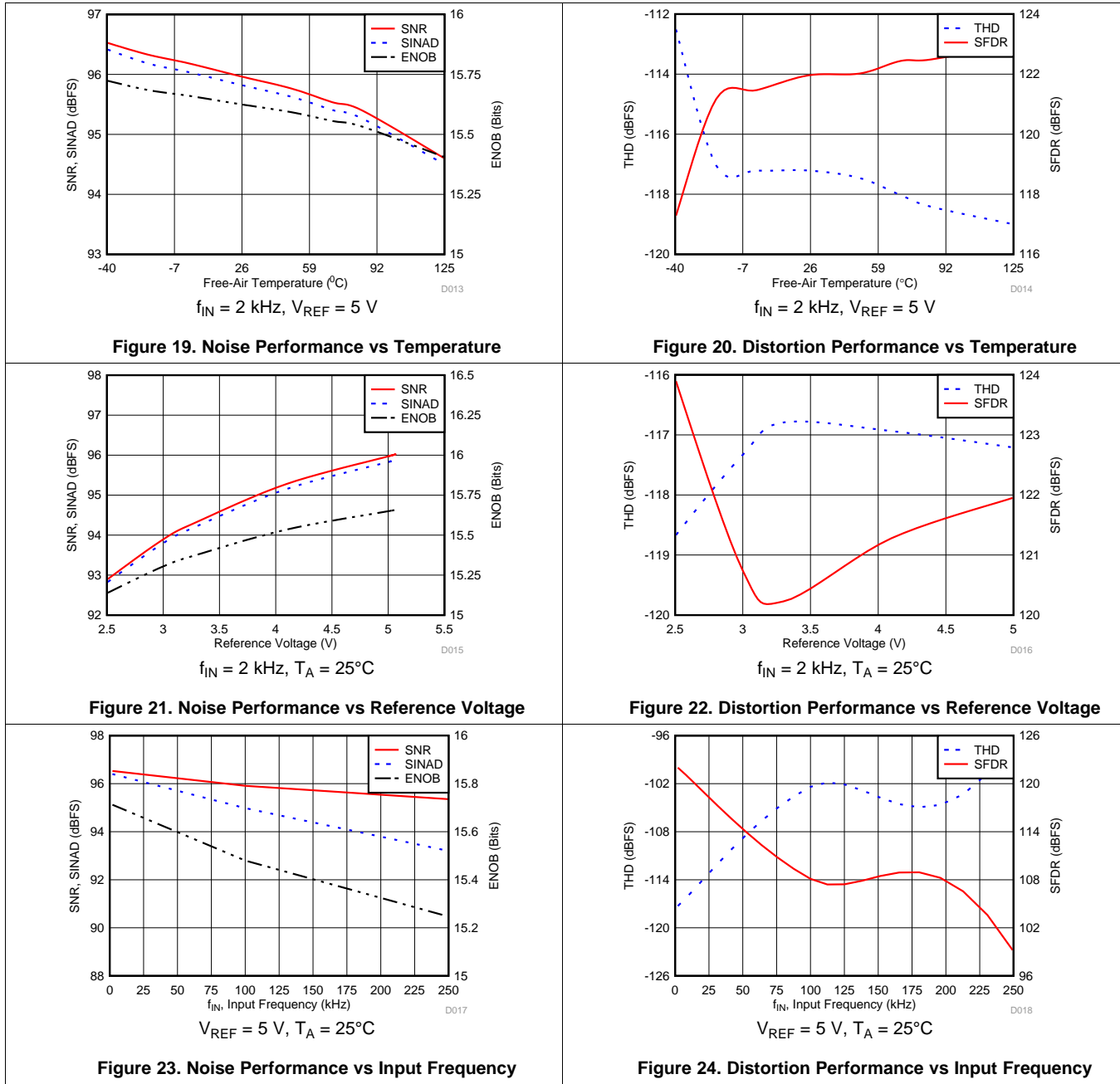

Figure 18. Typical FFT

### Typical Characteristics (continued)

at  $T_A = 25^\circ\text{C}$ ,  $AVDD = 1.8\text{ V}$ ,  $DVDD = 1.8\text{ V}$ ,  $V_{REF} = 5\text{ V}$ , and  $f_{SAMPLE} = 2.5\text{ MSPS}$  (unless otherwise noted)



Typical Characteristics (continued)

at  $T_A = 25^\circ\text{C}$ ,  $AVDD = 1.8\text{ V}$ ,  $DVDD = 1.8\text{ V}$ ,  $V_{REF} = 5\text{ V}$ , and  $f_{SAMPLE} = 2.5\text{ MSPS}$  (unless otherwise noted)

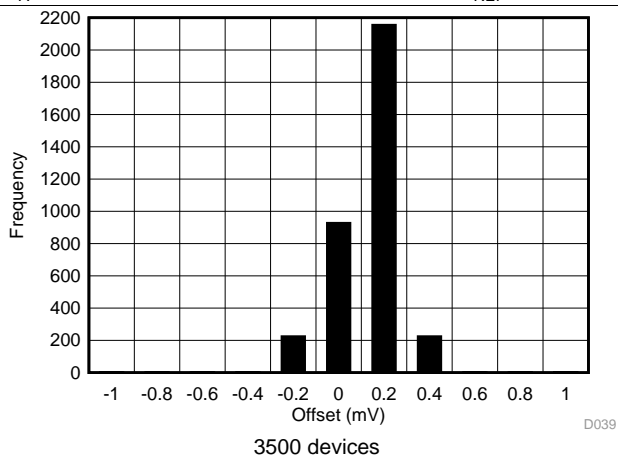

Figure 25. Offset Typical Distribution

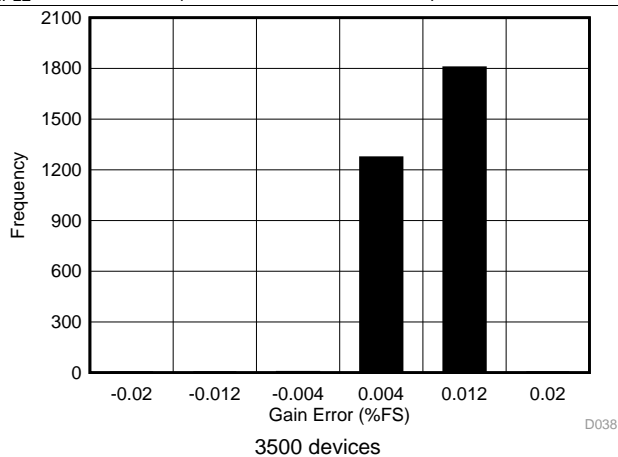

Figure 26. Gain Error Typical Distribution

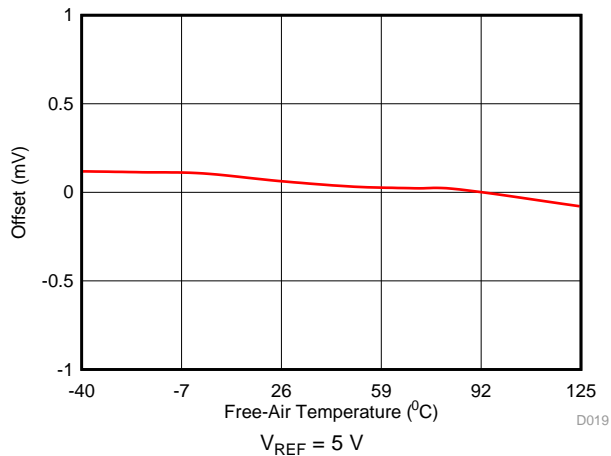

Figure 27. Offset vs Temperature

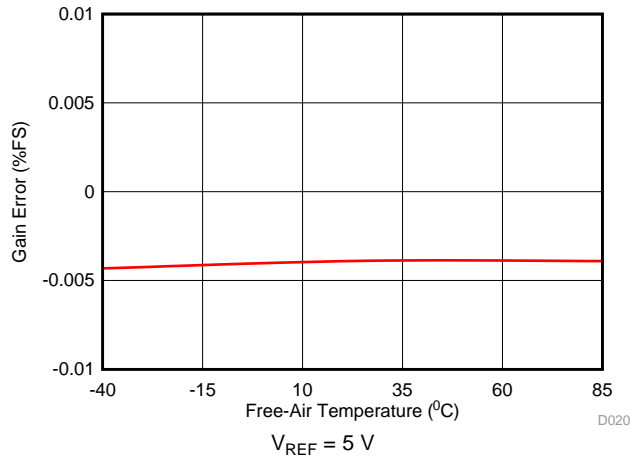

Figure 28. Gain Error vs Temperature

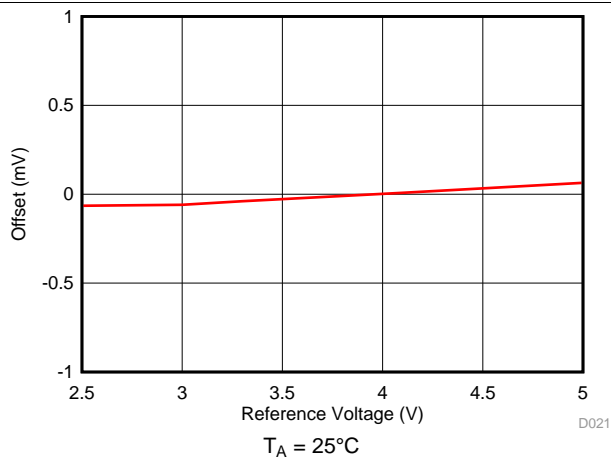

Figure 29. Offset vs Reference Voltage

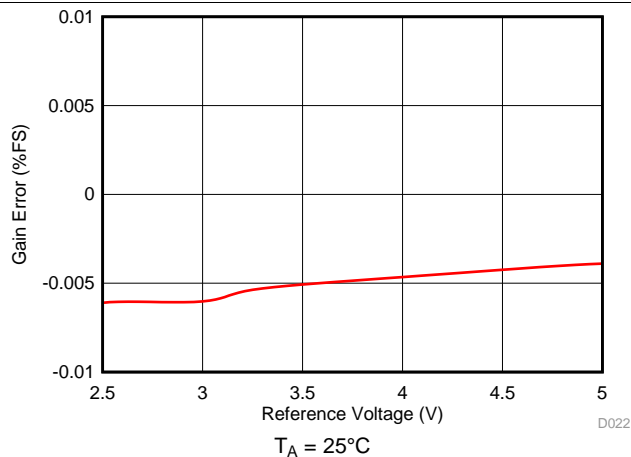

Figure 30. Gain Error vs Reference Voltage

Typical Characteristics (continued)

at  $T_A = 25^\circ\text{C}$ ,  $AVDD = 1.8\text{ V}$ ,  $DVDD = 1.8\text{ V}$ ,  $V_{REF} = 5\text{ V}$ , and  $f_{SAMPLE} = 2.5\text{ MSPS}$  (unless otherwise noted)

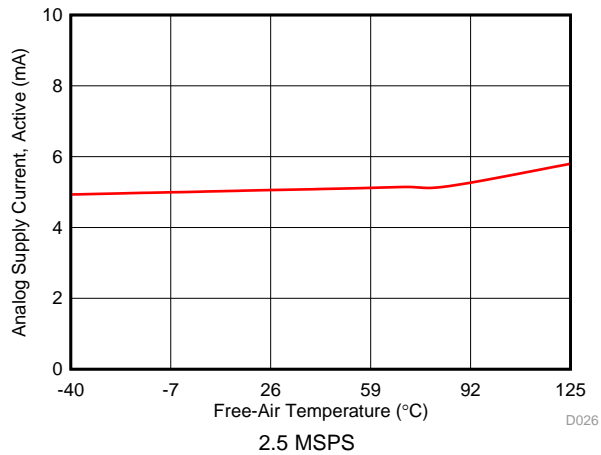

Figure 31. Supply Current vs Temperature

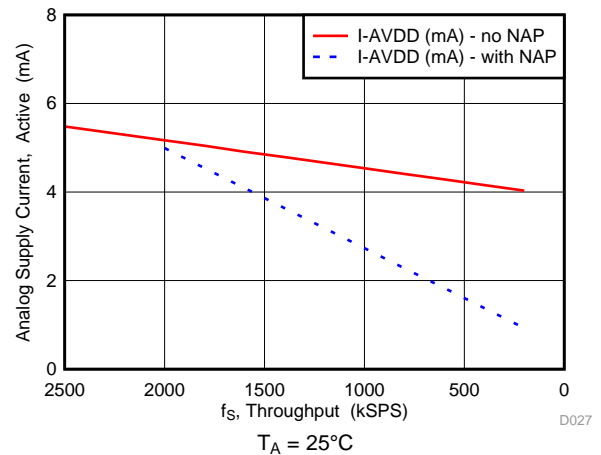

Figure 32. Supply Current vs Throughput

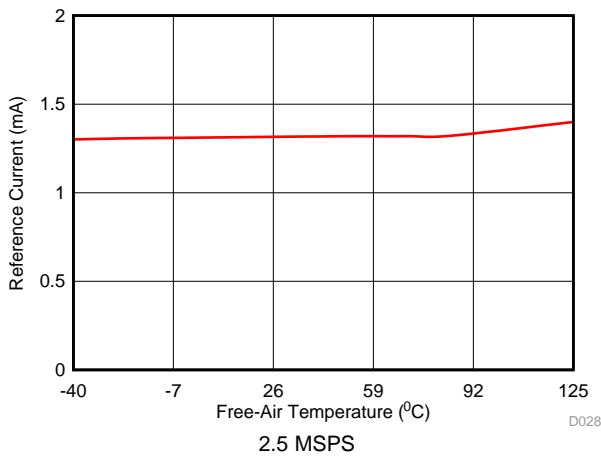

Figure 33. Reference Current vs Temperature

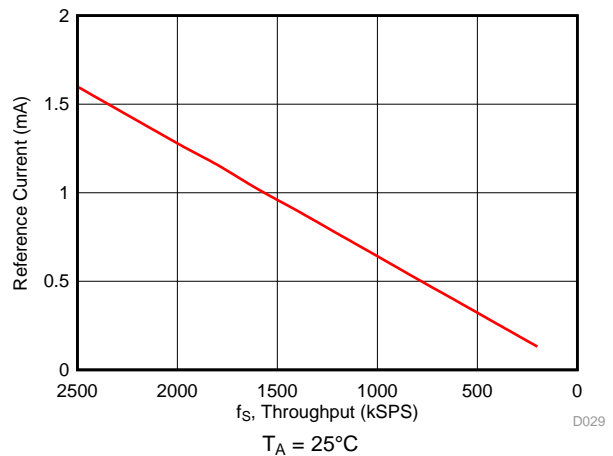

Figure 34. Reference Current vs Throughput

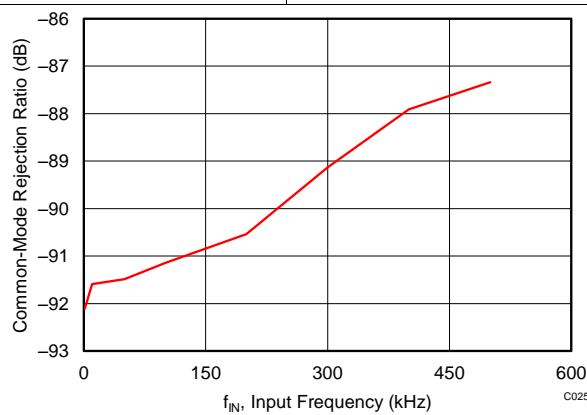

Figure 35. CMRR vs Input Frequency



## 7 Detailed Description

### 7.1 Overview

The ADS9120 is a high-speed, successive approximation register (SAR), analog-to-digital converter (ADC) based on the charge redistribution architecture. This compact device features high performance at a high throughput rate and at low power consumption.

The ADS9120 supports unipolar, fully-differential analog input signals and operates with a 2.5-V to 5-V external reference, offering a wide selection of input ranges without additional input scaling.

When a conversion is initiated, the differential input between the AINP and AINM pins is sampled on the internal capacitor array. The ADS9120 uses an internal clock to perform conversions. During the conversion process, both analog inputs are disconnected from the internal circuit. At the end of conversion process, the device reconnects the sampling capacitors to the AINP and AINM pins and enters acquisition phase.

The device consumes only 15.5 mW of power when operating at the full 2.5-MSPS throughput. Power consumption at lower throughputs can be reduced by using the flexible low-power modes (NAP and PD).

The new multiSPI™ interface simplifies board layout, timing, and firmware, and achieves high throughput at lower clock speeds, thus allowing easy interface to a variety of microprocessors, digital signal processors (DSPs), and field-programmable gate arrays (FPGAs).

### 7.2 Functional Block Diagram

From a functional perspective, the device comprises of two modules: the converter module and the interface module, as shown in this section.

The converter module samples and converts the analog input into an equivalent digital output code whereas the interface module facilitates communication and data transfer with the host controller.

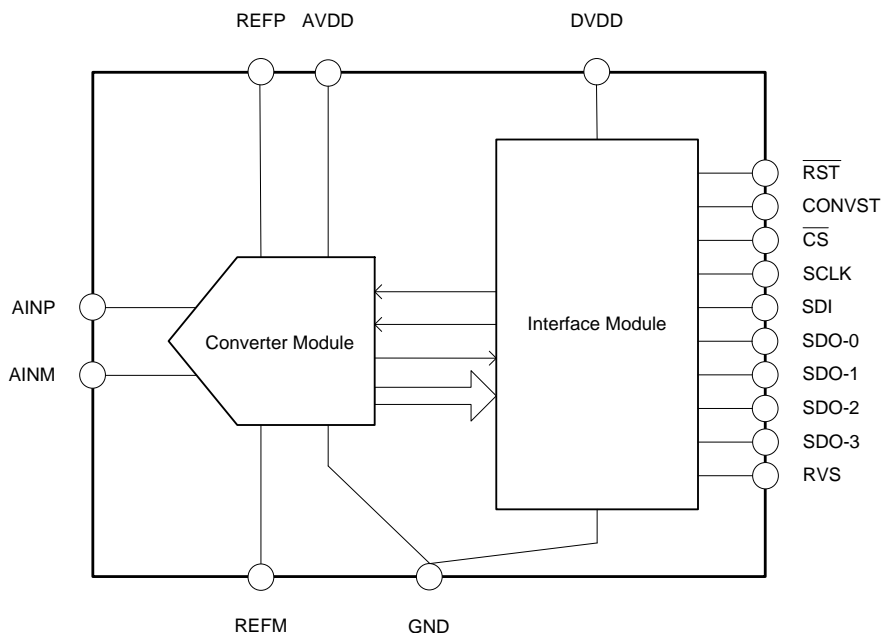

## 7.3 Feature Description

### 7.3.1 Converter Module

As shown in [Figure 36](#), the converter module samples the analog input signal (provided between the AINP and AINM pins), compares this signal with the reference voltage (provided between the pair of REFP and REFM pins), and generates an equivalent digital output code.

The converter module receives  $\overline{\text{RST}}$  and CONVST inputs from the interface module and outputs the ADCST signal and the conversion result back to the interface module.

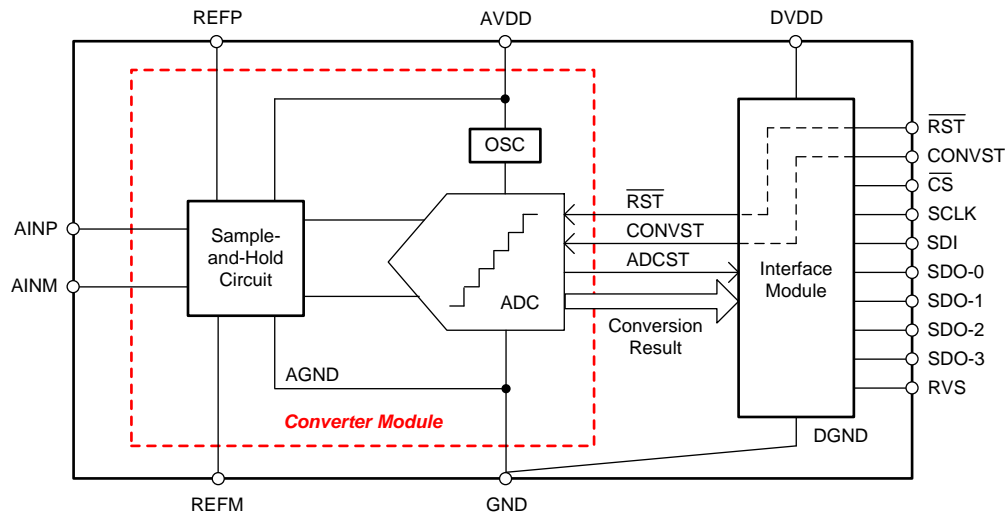

**Figure 36. Converter Module**

#### 7.3.1.1 Sample-and-Hold Circuit

The device supports unipolar, fully-differential analog input signals. [Figure 37](#) shows a small-signal equivalent circuit of the sample-and-hold circuit. Each sampling switch is represented by a resistance ( $R_{s1}$  and  $R_{s2}$ , typically  $30\ \Omega$ ) in series with an ideal switch ( $sw_1$  and  $sw_2$ ). The sampling capacitors,  $C_{s1}$  and  $C_{s2}$ , are typically  $60\ \text{pF}$ .

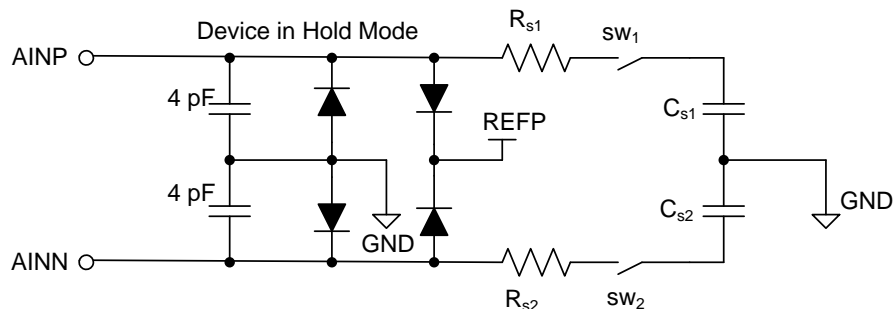

**Figure 37. Input Sampling Stage Equivalent Circuit**

During the acquisition process (in ACQ state), both positive and negative inputs are individually sampled on  $C_{s1}$  and  $C_{s2}$ , respectively. During the conversion process (in CNV state), the device converts for the voltage difference between the two sampled values:  $V_{\text{AINP}} - V_{\text{AINM}}$ .

Each analog input pin has electrostatic discharge (ESD) protection diodes to REFP and GND. Keep the analog inputs within the specified range to avoid turning the diodes on.

## Feature Description (continued)

Equation 1 and Equation 2 show the full-scale voltage range (FSR) and common-mode voltage range ( $V_{CM}$ ) supported at the analog inputs for any external reference voltage ( $V_{REF}$ ).

$$FSR = \pm V_{REF} \quad (1)$$

$$V_{CM} = \left( \frac{V_{REF}}{2} \right) \pm 0.1 \text{ V} \quad (2)$$

### 7.3.1.2 External Reference Source

The input range for the device is set by the external voltage applied at the two REFP pins. The REFM pins function as the reference ground and must be connected to each reference capacitor.

The device takes very little static current from the reference pins in the RST and ACQ states. During the conversion process (in CNV state), binary-weighted capacitors are switched onto the reference pins. The switching frequency is proportional to the conversion clock frequency, but the dynamic charge requirements are a function of the absolute values of the input voltage and the reference voltage. Reference capacitors decouple the dynamic reference loads and a low-impedance reference driver is required to keep the voltage regulated to within 1 LSB.

Most reference sources have very high broadband noise. The voltage reference source is recommended to be filtered with a 160-Hz filter before being connected to the reference driver, as shown in Figure 38. See the [ADC Reference Driver](#) section for the reference capacitor and driver selection. Also, the reference inputs are sensitive to board layout; thus, the layout guidelines described in the [Layout](#) section must be followed.

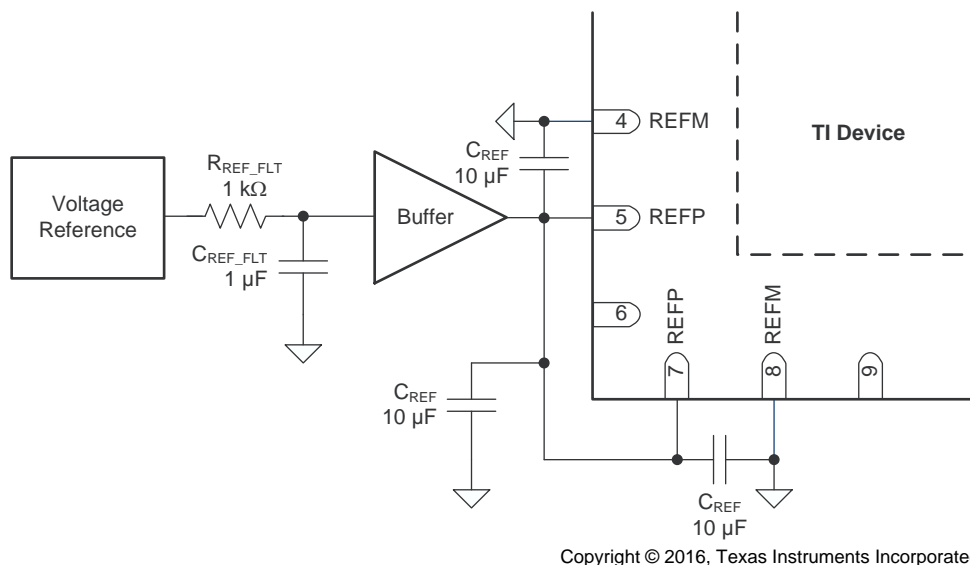

Figure 38. Reference Driver Schematic

### 7.3.1.3 Internal Oscillator

The device features an internal oscillator (OSC) that provides the conversion clock; see Figure 36. Conversion duration can vary but is bounded by the minimum and maximum value of  $t_{CONV}$ , as specified in the [Timing Requirements: Conversion Cycle](#) table.

The interface module can use this internal clock (OSC) or an external clock (provided by the host controller on the SCLK pin) or a combination of the internal and external clocks for executing the data transfer operations between the device and host controller; see the [Interface Module](#) section for more details.

## Feature Description (continued)

### 7.3.1.4 ADC Transfer Function

The ADS9120 supports unipolar, fully-differential analog inputs. The device output is in twos complement format. [Figure 39](#) and [Table 1](#) show the ideal transfer characteristics for the device.

The LSB for the ADC is given by [Equation 3](#):

$$1 \text{ LSB} = \frac{\text{FSR}}{2^{16}} = 2 \times \frac{V_{\text{REF}}}{2^{16}} \quad (3)$$

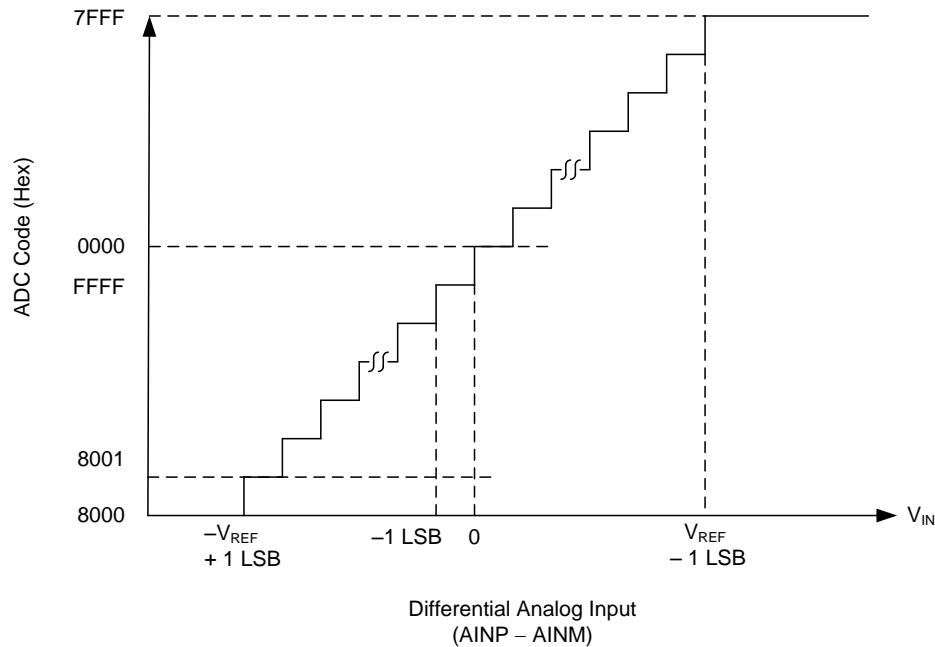

**Figure 39. Differential Transfer Characteristics**

**Table 1. Transfer Characteristics**

DIFFERENTIAL ANALOG INPUT VOLTAGE (AINP – AINM)	OUTPUT CODE (Hex)
< -V <sub>REF</sub>	8000
-V <sub>REF</sub> + 1 LSB	8001
-1 LSB	FFFF
0	0000
1 LSB	0001
> V <sub>REF</sub> - 1 LSB	7FFF

### 7.3.2 Interface Module

The interface module facilitates the communication and data transfer between the device and the host controller. As shown in Figure 40, the module comprises of shift registers (both input data and output data), configuration registers, and a protocol unit.

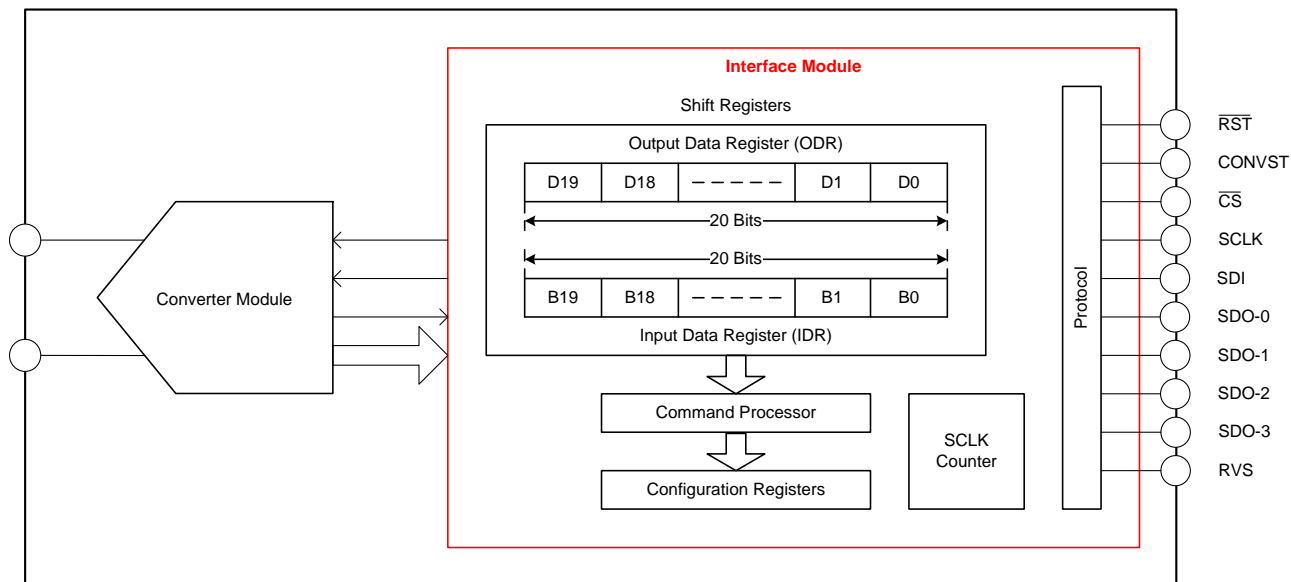

Figure 40. Interface Module

The [Pin Configuration and Functions](#) section provides descriptions of the interface pins; the [Data Transfer Frame](#) section details the functions of shift registers, the SCLK counter, and the command processor; the [Data Transfer Protocols](#) section details supported protocols; and the [Register Maps](#) section explains the configuration registers and bit settings.

### 7.4 Device Functional Modes

As shown in Figure 41, the device supports three functional states: RST, ACQ, and CNV. The device state is determined by the status of the CONVST and  $\overline{\text{RST}}$  control signals provided by the host controller.

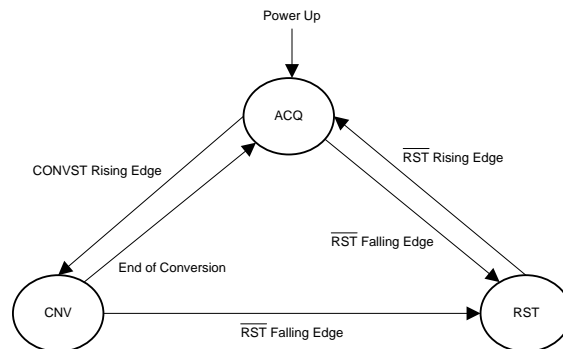

Figure 41. Device Functional States

#### 7.4.1 RST State

In the ADS9120, the  $\overline{\text{RST}}$  pin is an asynchronous digital input. To enter RST state, the host controller must pull the  $\overline{\text{RST}}$  pin low and keep it low for the  $t_{\text{wl\_RST}}$  duration (as specified in the *Timing Requirements: Asynchronous Reset, NAP, and PD* table).

In RST state, all configuration registers (see the *Register Maps* section) are reset to the default values, the RVS pins remain low, and the SDO-x pins are tri-stated.

To exit RST state, the host controller must pull the  $\overline{\text{RST}}$  pin high with CONVST and SCLK held low and  $\overline{\text{CS}}$  held high, as shown in Figure 42. After a delay of  $t_{\text{d\_rst}}$ , the device enters ACQ state and the RVS pin goes high.

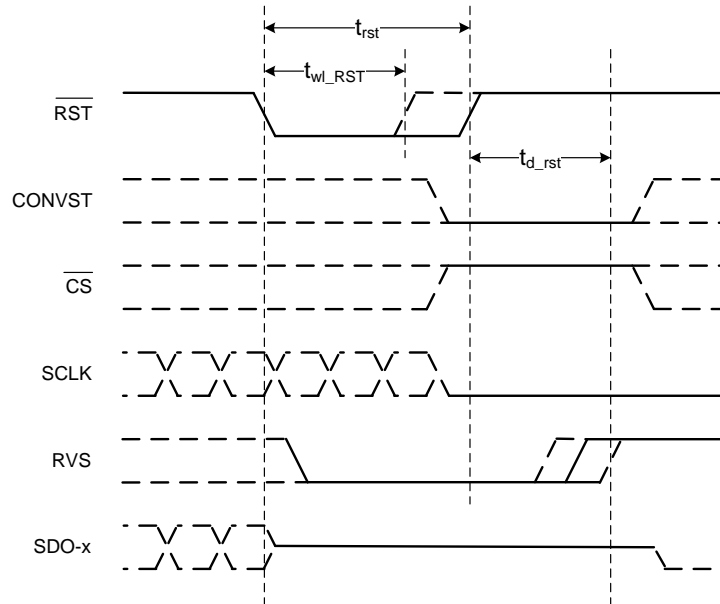

Figure 42. Asynchronous Reset

To operate the device in any of the other two states (ACQ or CNV),  $\overline{\text{RST}}$  must be held high. With  $\overline{\text{RST}}$  held high, transitions on the CONVST pin determine the functional state of the device.

## Device Functional Modes (continued)

Figure 43 shows a typical conversion process. An internal signal, ADCST, goes low during conversion and goes high at the end of conversion. With  $\overline{CS}$  held high, RVS reflects the status of ADCST.

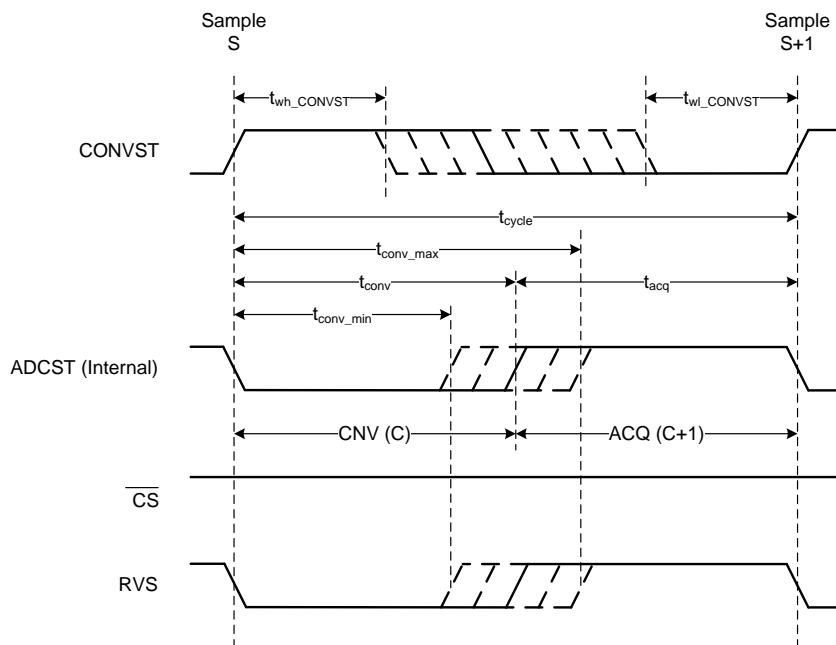

Figure 43. Typical Conversion Process

### 7.4.2 ACQ State

In ACQ state, the device acquires the analog input signal. The device enters ACQ state on power-up, after any asynchronous reset, or after end of every conversion.

An  $\overline{RST}$  falling edge takes the device from an ACQ state to a RST state. A CONVST rising edge takes the device from an ACQ state to a CNV state.

The device offers a low-power NAP mode to reduce power consumption in the ACQ state; see the [NAP Mode](#) section for more details on NAP mode.

### 7.4.3 CNV State

The device moves from ACQ state to CNV state on a rising edge of the CONVST pin. The conversion process uses an internal clock and the device ignores any further transitions on the CONVST signal until the ongoing conversion is complete (that is, during the time interval of  $t_{conv}$ ).

At the end of conversion, the device enters ACQ state. The cycle time for the device is given by [Equation 4](#):

$$t_{cycle-min} = t_{conv} + t_{acq-min} \quad (4)$$

#### NOTE

The conversion time,  $t_{conv}$ , can vary within the specified limits of  $t_{conv-min}$  and  $t_{conv-max}$  (as specified in the [Timing Requirements: Conversion Cycle](#) table). After initiating a conversion, the host controller must monitor for a low-to-high transition on the RVS pin or wait for the  $t_{conv-max}$  duration to elapse before initiating a new operation (data transfer or conversion). If RVS is not monitored, substitute  $t_{conv}$  in [Equation 4](#) with  $t_{conv-max}$ .

## 7.5 Programming

The device features four configuration registers (as described in the [Register Maps](#) section) and supports two types of data transfer operations: *data write* (the host configures the device), and *data read* (the host reads data from the device).

To access the internal configuration registers, the device supports the commands listed in [Table 2](#).

**Table 2. Supported Commands**

OPCODE B[19:0]	COMMAND ACRONYM	COMMAND DESCRIPTION
0000_0000_0000_0000_0000	NOP	No operation
1001_<8-bit address>_0000_0000	RD_REG	Read contents from the <8-bit address>
1010_<8-bit address>_<8-bit data>	WR_REG	Write <8-bit data> to the <8-bit address>
1111_1111_1111_1111_1111	NOP	No operation
Remaining combinations	Reserved	These commands are reserved and treated by the device as no operation

In the ADS9120, any data write to the device is always synchronous to the external clock provided on the SCLK pin. The data read from the device can be synchronized to the same external clock or to an internal clock of the device by programming the configuration registers (see the [Data Transfer Protocols](#) section for details).

In any data transfer frame, the contents of an internal, 20-bit, output data word are shifted out on the SDO pins. The D[19:4] bits of the 20-bit output data word for any frame (F+1), are determined by the:

- Settings of the DATA\_PATN[2:0] bits applicable to frame F+1 (see the [DATA\\_CNTL register](#)) and
- Command issued in frame F

If a valid RD\_REG command is executed in frame F, then the D[19:12] bits in frame F+1 reflect the contents of the selected register and the D[11:0] bits are 0s.

If the DATA\_PATN[2:0] bits for frame F+1 are set to 1xxb, then the D[19:4] bits in frame F+1 are the fixed data pattern shown in [Figure 44](#).

For all other combinations, the D[19:4] bits for frame F+1 are the latest conversion result.

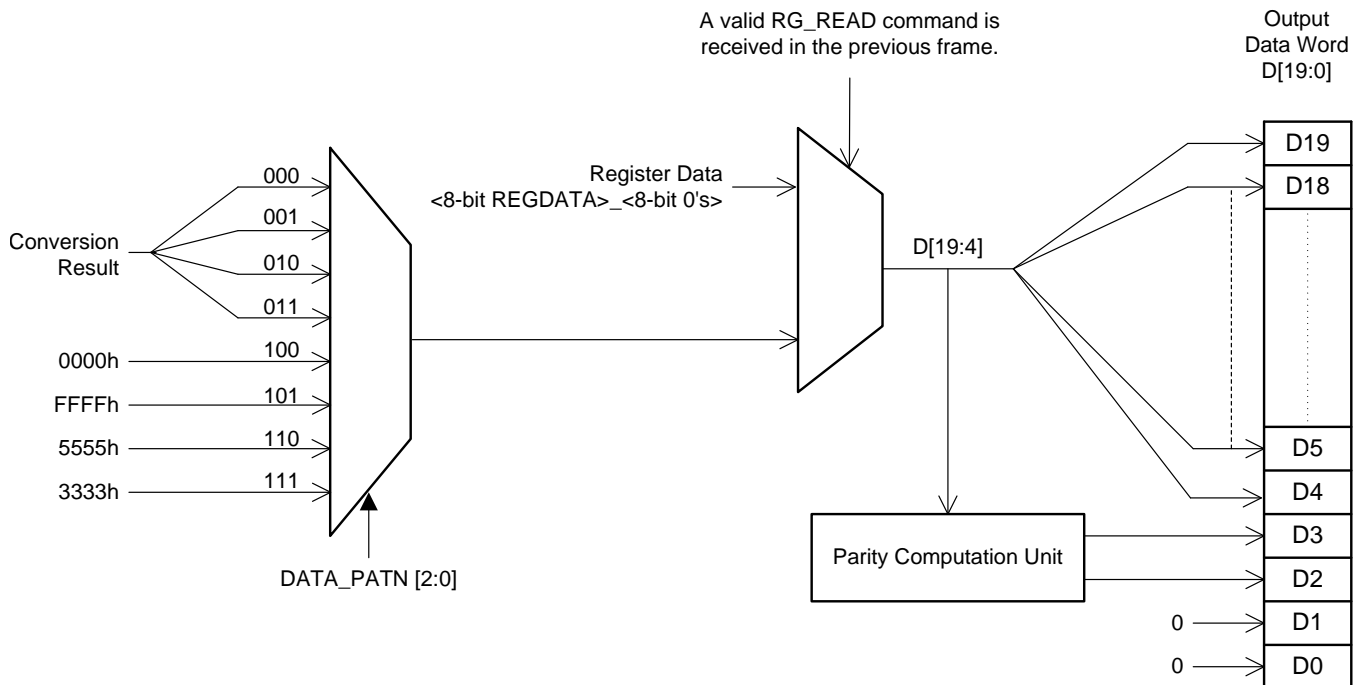

**Figure 44. Output Data Word (D[19:0])**



Figure 45 shows further details of the parity computation unit illustrated in Figure 44.

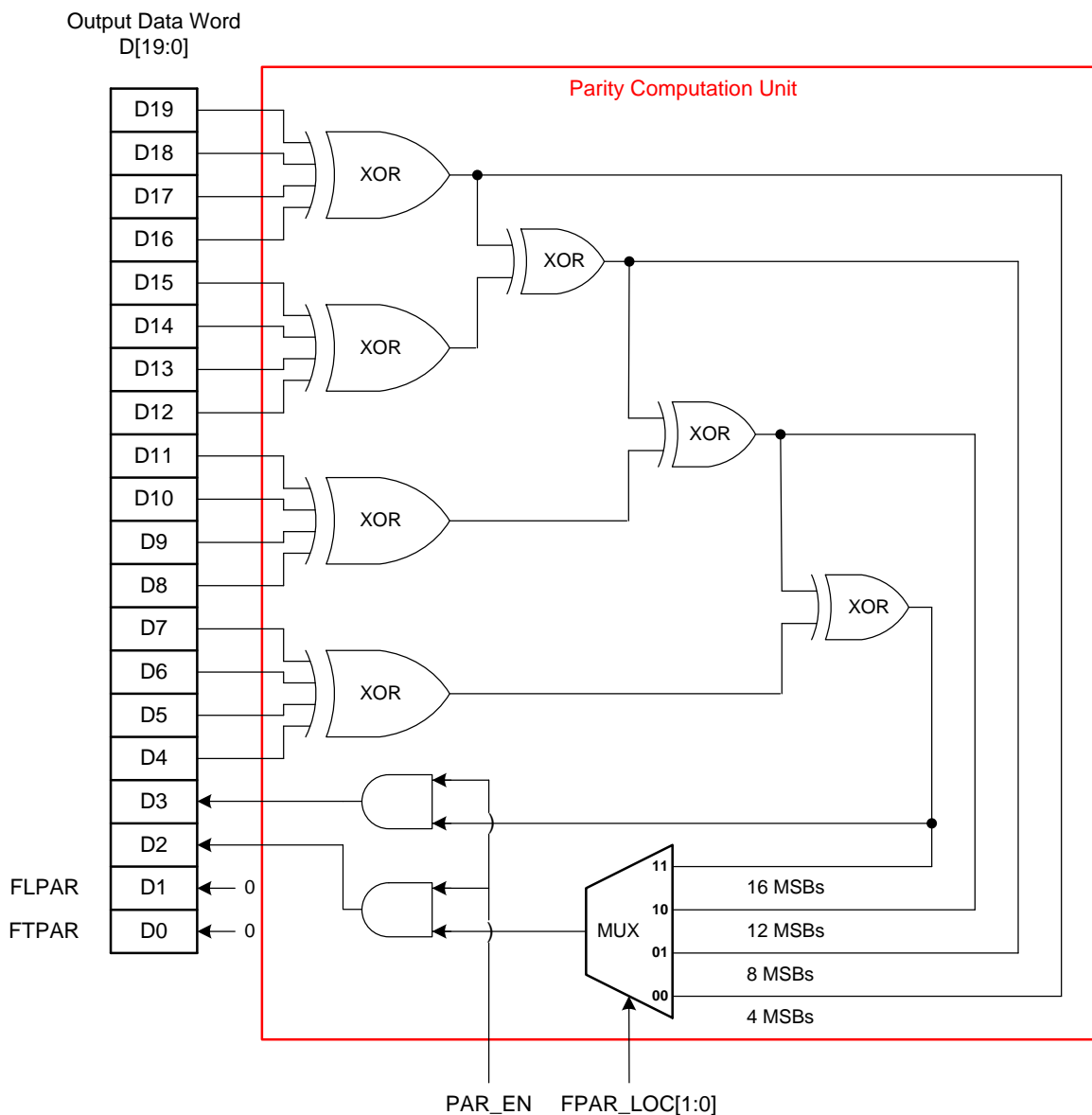

Figure 45. Parity Bits Computation

With the PAR\_EN bit set to 0, the D[3] and D[2] bits of the output data word are set to 0 (default configuration).

When the PAR\_EN bit is set to 1, the device calculates the parity bits (FLPAR and FTPAR) and appends them as bits D[3] and D[2].

- FLPAR is the even parity calculated on bits D[19:4].
- FTPAR is the even parity calculated on the bits defined by FPAR\_LOC[1:0].

See the [DATA\\_CNTL register](#) for more details on the FPAR\_LOC[1:0] bit settings.

The D[1] and D[0] bits are always set to 0.

### 7.5.1 Data Transfer Frame

A data transfer frame between the device and the host controller is bounded between a  $\overline{CS}$  falling edge and the subsequent  $\overline{CS}$  rising edge. The host controller can initiate a data transfer frame (as shown in Figure 46) at any time irrespective of the status of the CONVST signal; however, the data read during such a data transfer frame is a function of relative timing between the CONVST and  $\overline{CS}$  signals.

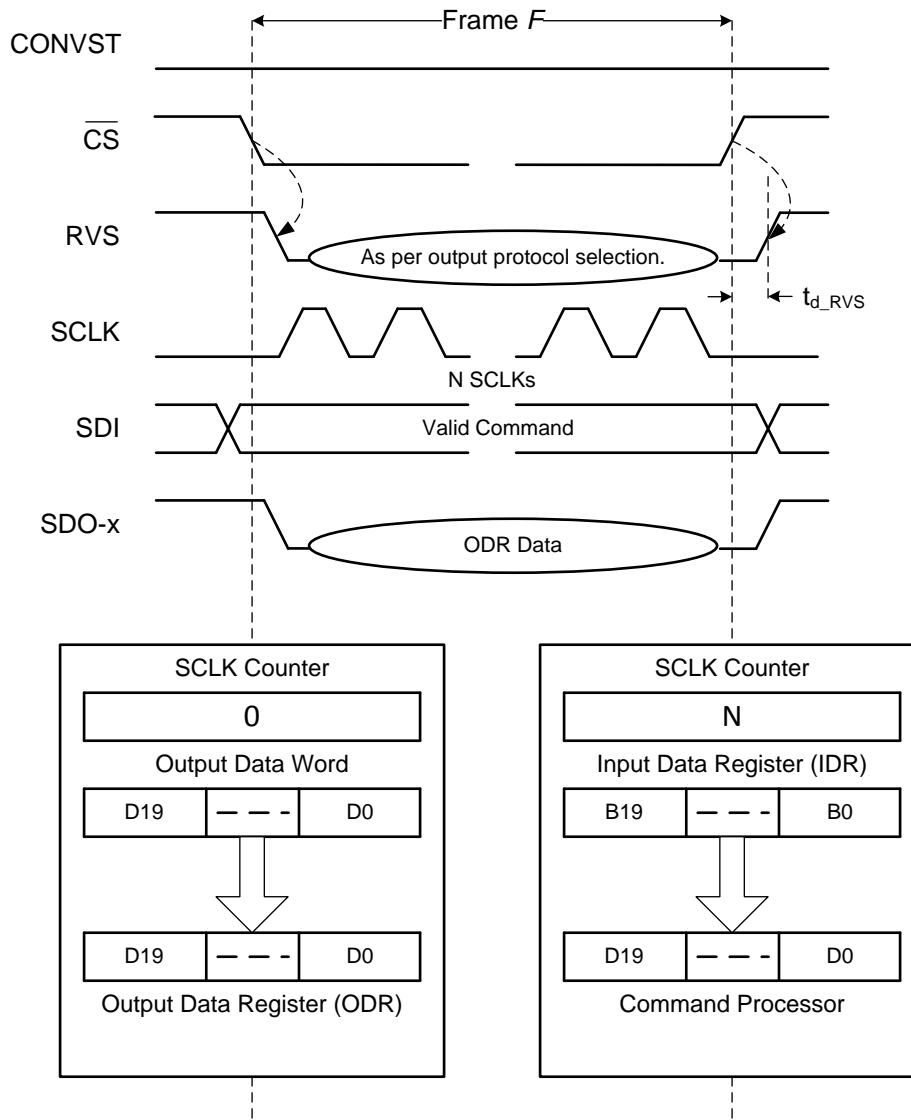

Figure 46. Data Transfer Frame

For this discussion, assume that the CONVST signal remains low.

For a typical data transfer frame F:

1. The host controller pulls  $\overline{CS}$  low to initiate a data transfer frame. On the  $\overline{CS}$  falling edge:
  - RVS goes low, indicating the beginning of the data transfer frame.
  - The SCLK counter is reset to 0.
  - The device takes control of the data bus. As shown in Figure 46, the 20-bit contents of the output data word (see Figure 44) are loaded in to the 20-bit ODR (see Figure 40).
  - The 20-bit IDR (see Figure 40) is reset to 00000h, corresponding to a NOP command.

2. During the frame, the host controller provides clocks on the SCLK pin:
  - On each SCLK capture edge, the SCLK counter is incremented and the data bit received on the SDI pin is shifted in to the IDR.
  - On each launch edge of the output clock (SCLK in this case), ODR data are shifted out on the selected SDO-x pins.
  - The status of the RVS pin depends on the output protocol selection (see the [Protocols for Reading From the Device](#) section).
3. The host controller pulls  $\overline{CS}$  high to end the data transfer frame. On the  $\overline{CS}$  rising edge:
  - The SDO-x pins go to tri-state.
  - RVS goes high (after a delay of  $t_{d\_RVS}$ ).
  - As illustrated in [Figure 46](#), the 20-bit contents of the IDR are transferred to the command processor (see [Figure 40](#)) for decoding and further action.

After pulling  $\overline{CS}$  high, the host controller must monitor for a low-to-high transition on the RVS pin or wait for the  $t_{d\_RVS}$  time (see the [Timing Requirements: SPI-Compatible Serial Interface](#) table) to elapse before initiating a new operation (data transfer or conversion). The delay,  $t_{d\_RVS}$ , for any data transfer frame F varies based on the data transfer operation executed in the frame F.

At the end of the data transfer frame F:

- If the SCLK counter is  $< 20$ , it indicates that IDR has captured less than 20 bits from the SDI. In this case, the device treats the frame F as a *short command frame*. At the end of a short command frame, IDR is not updated and the device treats the frame as a no operation command.
- If the SCLK counter = 20, it indicates that the IDR has captured exactly 20 bits from SDI. In this case, the device treats the frame F as a *optimal command frame*. At the end of an optimal command frame, the command processor decodes the 20-bit contents of the IDR as a valid command word.
- If the SCLK counter  $> 20$ , it indicates that the IDR captured more than 20 bits from the SDI, and only the *last 20 bits* have been retained. In this case, the device treats the frame F as a *long command frame*. At the end of a long command frame, the command processor treats the 20-bit contents of the IDR as a valid command word. There is no restriction on the maximum number of clocks that can be provided within any data transfer frame F. However, as explained above, the last 20 bits shifted into the device prior to the  $\overline{CS}$  rising edge must constitute the desired command.

In a short command frame, the write operation to the device is invalidated, however, the output data bits transferred during the frame are still valid output data. Therefore, the host controller can use such shorter data transfer frames to read only the required number of MSB bits from the 20-bit output data word. As shown in [Figure 44](#), an *optimal read frame* for ADS9120 needs to read only the 16 MSB bits of the output data word. The length of an optimal read frame depends on the output protocol selection; refer to the [Protocols for Reading From the Device](#) section for more details.

---

#### NOTE

The example above shows data read and data write operations synchronous to the external clock provided on the SCLK pin.

The device also supports data read operation synchronous to the internal clock; see the [Protocols for Reading From the Device](#) section for more details. In this case, while the ODR contents are shifted on the SDO(s) on the launch edge of the internal clock, the device continues to capture the SDI data into IDR (and increment the SCLK counter) on SCLK capture edges.

---

## 7.5.2 Interleaving Conversion Cycles and Data Transfer Frames

The host controller can operate the ADS9120 at the desired throughput by interleaving the conversion cycles and the data transfer frames.

The cycle time of the device,  $t_{\text{cycle}}$ , is the time difference between two consecutive CONVST rising edges provided by the host controller. The response time of the device,  $t_{\text{resp}}$ , is the time difference between the host controller initiating a conversion C and the host controller receiving the complete result for conversion C.

Figure 47 shows three conversion cycles, C, C+1, and C+2. Conversion C is initiated by a CONVST rising edge at the  $t = 0$  time and the conversion result becomes available for data transfer at the  $t_{\text{conv}}$  time. However, this result is loaded into the ODR only on the subsequent CS falling edge. This CS falling edge must be provided before the completion of the conversion C+1 (that is, before the  $t_{\text{cycle}} + t_{\text{conv}}$  time).

To achieve the rated performance specifications, the host controller must ensure that no digital signals toggle during the quiet acquisition time ( $t_{\text{qt\_acq}}$ ) and quiet aperture time ( $t_{\text{d\_cnvcap}}$ ), as shown in Figure 47. Any noise during  $t_{\text{d\_cnvcap}}$  can negatively affect the result of the ongoing conversion whereas any noise during  $t_{\text{qt\_acq}}$  can negatively affect the acquisition of the subsequent sample (and hence it's conversion result).

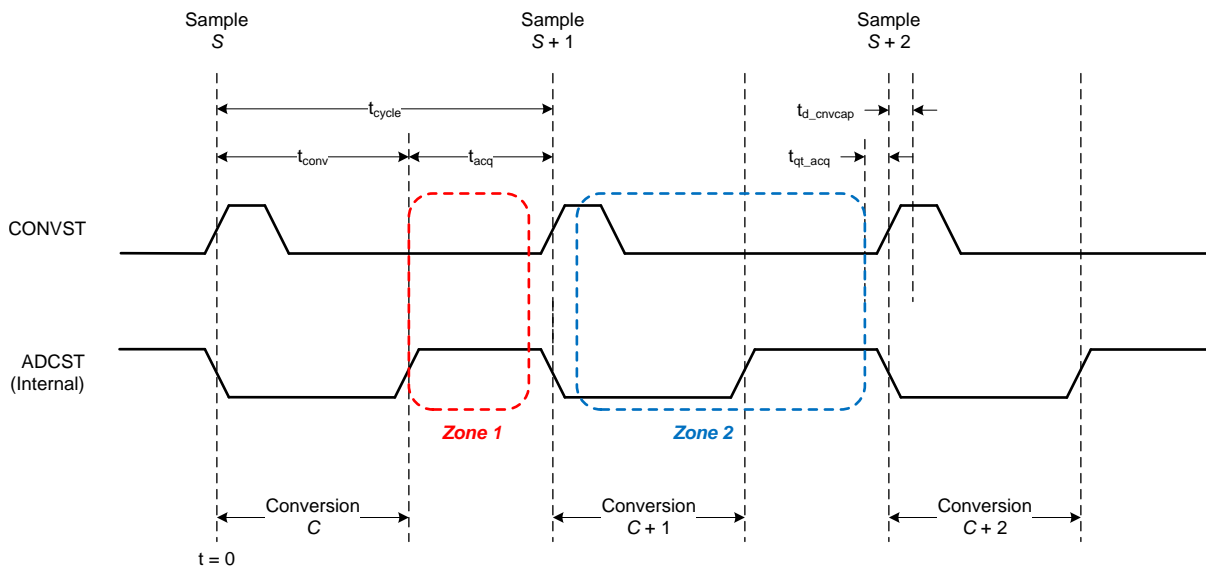

**Figure 47. Data Transfer Zones**

This architecture allows for two distinct time zones (zone1 and zone2) to transfer data for each conversion. Zone1 and zone2 for conversion C are defined in Table 3.

**Table 3. Data Transfer Zones Timing**

ZONE	STARTING TIME	ENDING TIME
Zone1 for conversion C	$t_{\text{conv}}$	$t_{\text{cycle}} - t_{\text{qt\_acq}}$
Zone2 for conversion C	$t_{\text{cycle}} + t_{\text{d\_cnvcap}}$	$t_{\text{cycle}} + t_{\text{cycle}} - t_{\text{qt\_acq}}$

The response time includes the conversion time and the data transfer time, and is thus a function of the data transfer zone selected.

Figure 48 and Figure 49 illustrate interleaving of three conversion cycles (C, C+1, and C+2) with three data transfer frames (F, F+1, and F+2) in zone1 and in zone2, respectively.

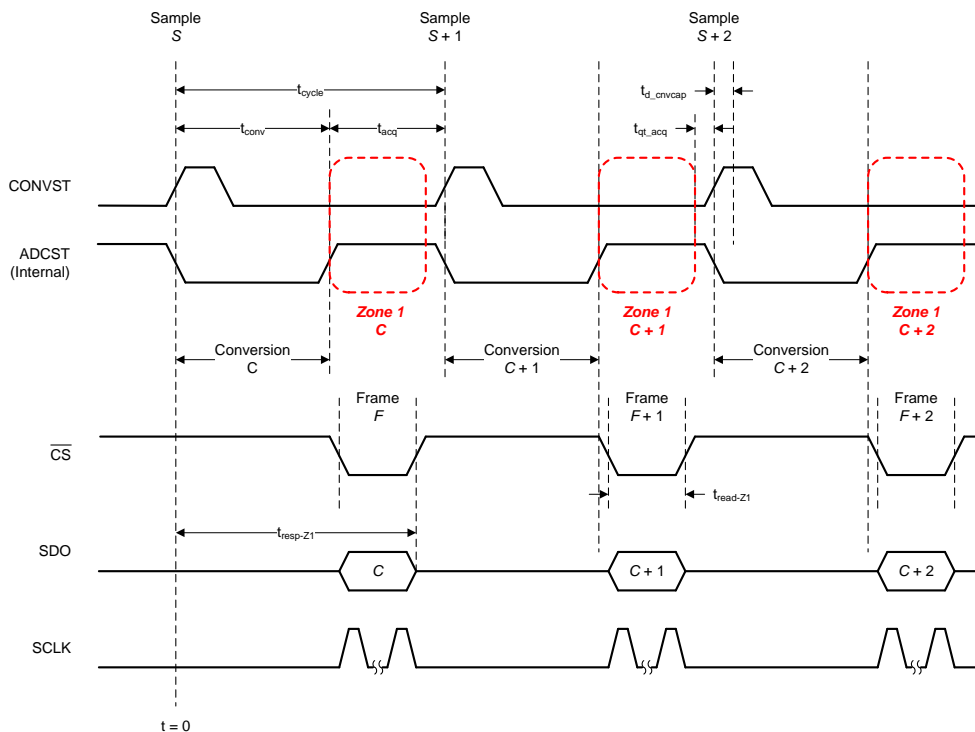

Figure 48. Zone1 Data Transfer

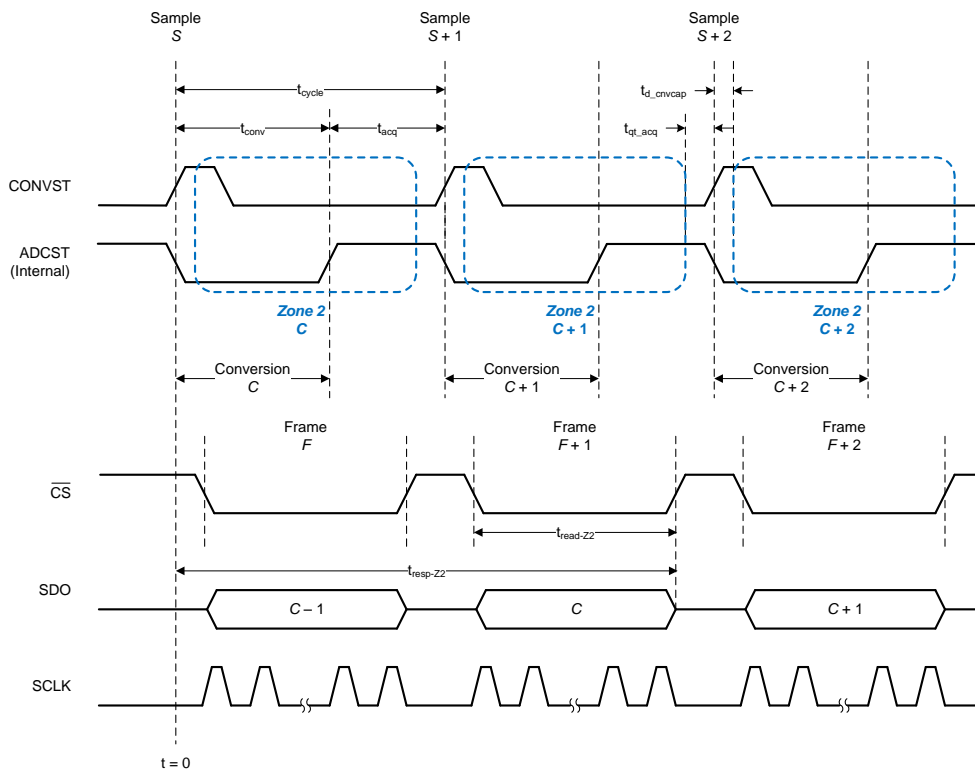

Figure 49. Zone2 Data Transfer

To achieve cycle time,  $t_{\text{cycle}}$ , the read time in zone1 is given by [Equation 5](#):

$$t_{\text{read-Z1}} \leq t_{\text{cycle}} - t_{\text{conv}} - t_{\text{qt\_acq}} \quad (5)$$

For an *optimal read frame*, [Equation 5](#) results in an SCLK frequency given by [Equation 6](#):

$$f_{\text{SCLK}} \geq \frac{16}{t_{\text{read-Z1}}} \quad (6)$$

Then, the zone1 data transfer achieves a response time defined by [Equation 7](#):

$$t_{\text{resp-Z1-min}} = t_{\text{conv}} + t_{\text{read-Z1}} \quad (7)$$

As an example, when operating the ADS9120 at the full throughput of 2.5 MSPS, the host controller can achieve a response time of 400 ns provided that the data transfer in zone1 is completed within 85 ns. However, to achieve this response time, the SCLK frequency must be greater than 188 MHz.

Note that the device does not support such high SCLK speeds.

Data transfer in zone2 can achieve lower SCLK speeds for the same cycle time. The read time in zone2 is given by [Equation 8](#):

$$t_{\text{read-Z2}} \leq t_{\text{cycle}} - t_{\text{d\_cnvcap}} - t_{\text{qt\_acq}} \quad (8)$$

For an optimal data transfer frame, [Equation 8](#) results in an SCLK frequency given by [Equation 9](#):

$$f_{\text{SCLK}} \geq \frac{16}{t_{\text{read\_Z2}}} \quad (9)$$

Then, the zone2 data transfer achieves a response time defined by [Equation 10](#):

$$t_{\text{resp-Z2-min}} = t_{\text{cycle}} + t_{\text{d\_cnvcap}} + t_{\text{read-Z2}} \quad (10)$$

As an example, the host controller can operate the ADS9120 at the full throughput of 2.5 MSPS using zone2 data transfer with a 44 MHz SCLK (and a read time of 365 ns). However, zone2 data transfer results in a response time of nearly 800 ns.

There is no upper limit on  $t_{\text{read-Z1}}$  and  $t_{\text{read-Z2}}$ , however, any increase in these read times will increase the response time and may increase the cycle time.

For a given cycle time, the zone1 data transfer clearly achieves faster response time but also requires a higher SCLK speed (as evident from [Equation 5](#), [Equation 6](#), and [Equation 7](#)), whereas the zone2 data transfer clearly requires a lower SCLK speed but supports slower response time (as evident from [Equation 8](#), [Equation 9](#), and [Equation 10](#)).

---

#### NOTE

In zone2, the data transfer is active when the device is converting for the next analog sample. This digital activity can interfere with the ongoing conversion and cause some degradation in SNR performance.

Additionally, a data transfer frame can begin in zone1 and then extend into zone2; however, the host controller must ensure that no digital transitions occur during the  $t_{\text{qt\_acq}}$  and  $t_{\text{d\_cnvcap}}$  time intervals.

---

### 7.5.3 Data Transfer Protocols

The device features a multiSPI™ interface that allows the host controller to operate at slower SCLK speeds and still achieve the required cycle time with a faster response time. The multiSPI™ interface module offers two options to reduce the SCLK speed required for data transfer:

1. An option to increase the width of the output data bus
2. An option to enable double data rate (DDR) transfer

These two options can be combined to achieve further reduction in SCLK speed.

Figure 50 shows the delays between the host controller and the device in a typical serial communication.

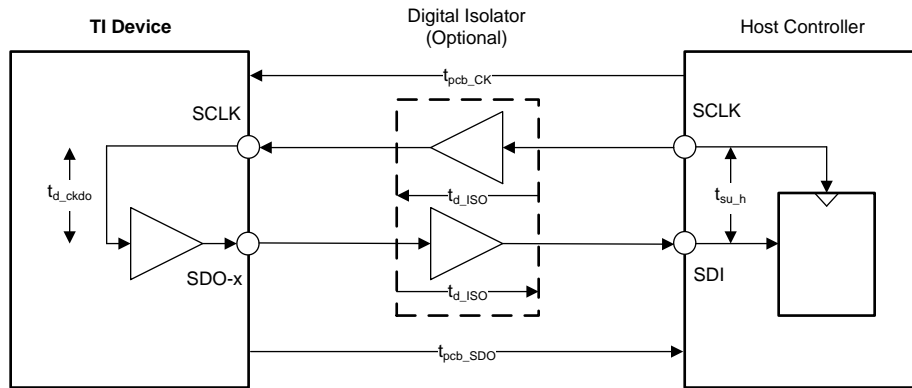

Copyright © 2016, Texas Instruments Incorporated

Figure 50. Delays in Serial Communication

If  $t_{pcb\_CK}$  and  $t_{pcb\_SDO}$  are the delays introduced by the PCB traces for the serial clock and SDO signals,  $t_{d\_CKDO}$  is the clock-to-data delay of the device,  $t_{d\_ISO}$  is the propagation delay introduced by the digital isolator, and  $t_{su\_h}$  is the set up time specification of the host controller, then the total delay in the path is given by Equation 11:

$$t_{d\_total\_serial} = t_{pcb\_CK} + t_{d\_iso} + t_{d\_ckdo} + t_{d\_iso} + t_{pcb\_SDO} + t_{su\_h} \quad (11)$$

In a standard SPI protocol, the host controller and the device launch and capture data bits on alternate SCLK edges. Therefore, the  $t_{d\_total\_serial}$  delay must be kept less than half of the SCLK duration. Equation 12 shows the fastest clock allowed by the SPI protocol.

$$f_{clk-SPI} \leq \frac{1}{2 \times t_{d\_total\_serial}} \quad (12)$$

Larger values of the  $t_{d\_total\_serial}$  delay restrict the maximum SCLK speed for the SPI protocol, resulting in higher read and response times, and can increase cycle times. To remove this restriction on the SCLK speed, the multiSPI™ interface module supports an ADC-Clock-Master or a *source-synchronous* mode of operation.

As illustrated in Figure 51, in the ADC-Clock-Master or source-synchronous mode, the device provides a synchronous output clock (on the RVS pin) along with the output data (on the SDO-x pins).

For negligible values of  $t_{off\_STRDO}$ , the total delay in the path for a source-synchronous data transfer, is given by Equation 13:

$$t_{d\_total\_srcsync} = t_{pcb\_RVS} - t_{pcb\_SDO} + t_{su\_h} \quad (13)$$

As illustrated in Equation 11 and Equation 13, the ADC-Clock-Master or source-synchronous mode completely eliminates the affect of isolator delays ( $t_{d\_ISO}$ ) and the clock-to-data delays ( $t_{d\_CKDO}$ ), which are typically the largest contributors in the overall delay computation.

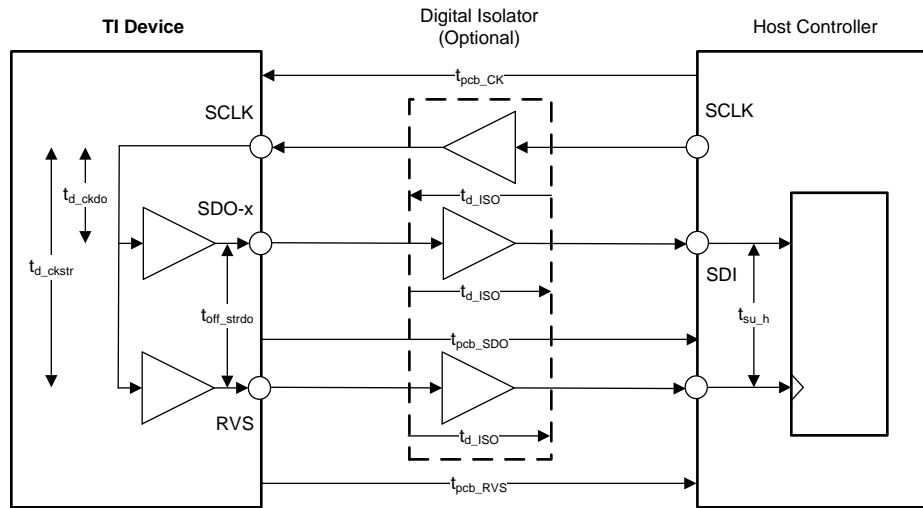

Copyright © 2016, Texas Instruments Incorporated

**Figure 51. Delays in Source-Synchronous Communication**

Furthermore, the actual values of  $t_{pcb\_RVS}$  and  $t_{pcb\_SDO}$  do not matter. In most cases, the  $t_{d\_total\_srcsync}$  delay can be kept at a minimum by routing the RVS and SDO lines together on the PCB. Therefore, the ADC-Clock-Master or source-synchronous mode allows the data transfer between the host controller and the device to operate at much higher SCLK speeds.

**7.5.3.1 Protocols for Configuring the Device**

As shown in [Table 4](#), the host controller can use any of the four legacy, SPI-compatible protocols (SPI-00-S, SPI-01-S, SPI-10-S, or SPI-11-S) to write data in to the device.

**Table 4. SPI Protocols for Configuring the Device**

PROTOCOL	SCLK POLARITY (At CS Falling Edge)	SCLK PHASE (Capture Edge)	SDI_CNTL	SDO_CNTL	#SCLK (Optimal Command Frame)	DIAGRAM
SPI-00-S	Low	Rising	00h	00h	20	<a href="#">Figure 52</a>
SPI-01-S	Low	Falling	01h	00h	20	<a href="#">Figure 53</a>
SPI-10-S	High	Falling	02h	00h	20	<a href="#">Figure 54</a>
SPI-11-S	High	Rising	03h	00h	20	<a href="#">Figure 55</a>

On power-up or after coming out of any asynchronous reset, the device supports the SPI-00-S protocol for data read and data write operations.

To select a different SPI-compatible protocol, program the SDI\_MODE[1:0] bits in the [SDI\\_CNTL register](#). This first write operation must adhere to the SPI-00-S protocol. Any subsequent data transfer frames must adhere to the newly selected protocol.

[Figure 52](#) to [Figure 55](#) detail the four protocols using an optimal command frame; see the [Timing Requirements: SPI-Compatible Serial Interface](#) section for associated timing parameters.

**NOTE**

As explained in the [Data Transfer Frame](#) section, a valid write operation to the device requires a minimum of 20 SCLKs to be provided within a data transfer frame.

Any data write operation to the device must continue to follow the SPI-compatible protocol selected in the [SDI\\_CNTL register](#), irrespective of the protocol selected for the data read operation.



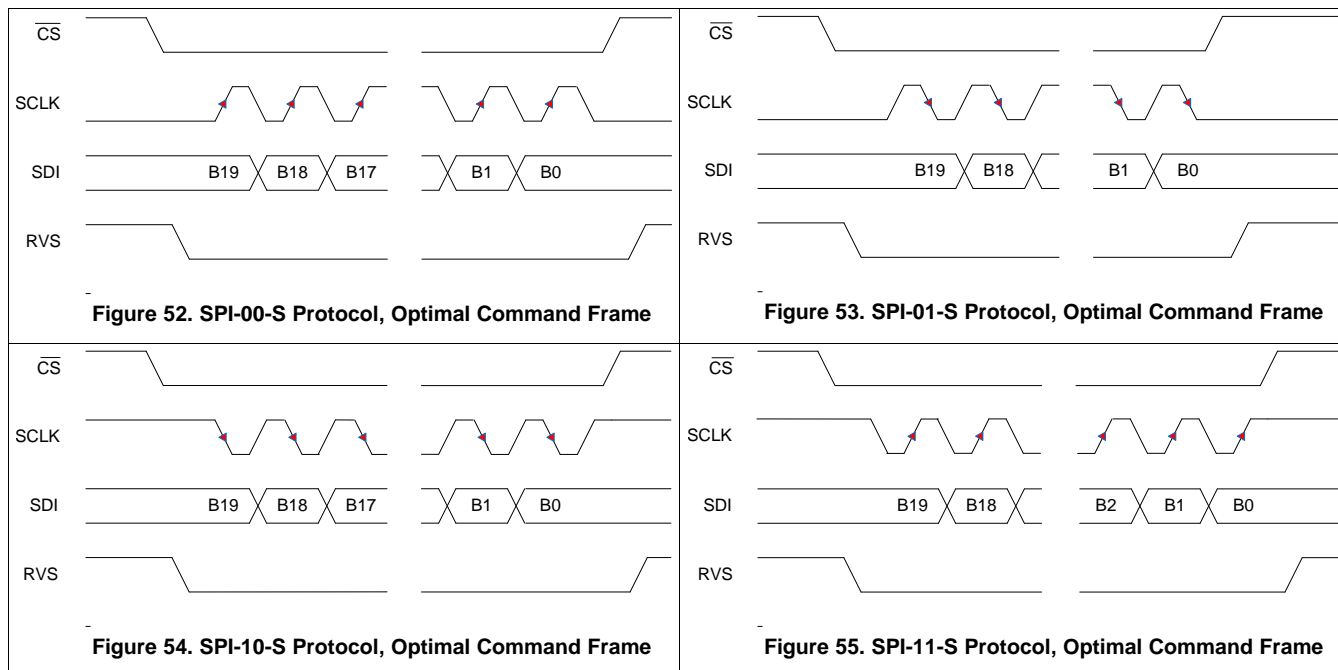

**7.5.3.2 Protocols for Reading From the Device**

The protocols for the data read operation can be broadly classified into three categories:

1. Legacy, SPI-compatible (SPI-xy-S) protocols,
2. SPI-compatible protocols with bus width options (SPI-xy-D and SPI-xy-Q), and
3. Source-synchronous (SRC) protocols

**7.5.3.2.1 Legacy, SPI-Compatible (SYS-xy-S) Protocols**

As shown in Table 5, the host controller can use any of the four legacy, SPI-compatible protocols (SPI-00-S, SPI-01-S, SPI-10-S, or SPI-11-S) to read data from the device.

**Table 5. SPI Protocols for Reading From the Device**

PROTOCOL	SCLK POLARITY (At $\overline{CS}$ Falling Edge)	SCLK PHASE (Capture Edge)	MSB BIT LAUNCH EDGE	SDI_CNTL	SDO_CNTL	#SCLK (Optimal Read Frame)	DIAGRAM
SPI-00-S	Low	Rising	$\overline{CS}$ falling	00h	00h	16	Figure 56
SPI-01-S	Low	Falling	1 <sup>st</sup> SCLK rising	01h	00h	16	Figure 57
SPI-10-S	High	Falling	$\overline{CS}$ falling	02h	00h	16	Figure 58
SPI-11-S	High	Rising	1 <sup>st</sup> SCLK falling	03h	00h	16	Figure 59

On power-up or after coming out of any asynchronous reset, the device supports the SPI-00-S protocol for data read and data write operations. To select a different SPI-compatible protocol for both the data transfer operations:

1. Program the SDI\_MODE[1:0] bits in the SDI\_CNTL register. This first write operation must adhere to the SPI-00-S protocol. Any subsequent data transfer frames must adhere to the newly selected protocol.
2. Set the SDO\_MODE[1:0] bits = 00b in the SDO\_CNTL register.

When using any of the SPI-compatible protocols, the RVS output remains low throughout the data transfer frame; see the *Timing Requirements: SPI-Compatible Serial Interface* table for associated timing parameters.

**NOTE**

It is recommended to use any of the four SPI-compatible protocols to execute the RD\_REG and WR\_REG operations specified in Table 2.

Figure 56 to Figure 59 explain the details of the four protocols using an optimal command frame to read all 20 bits of the output data word. Table 5 shows the number of SCLK required in an optimal read frame for the different output protocol selections.

With SDO\_CNTL[7:0] = 00h, if the host controller uses a long data transfer frame, the device exhibits daisy-chain operation (see the *Multiple Devices: Daisy-Chain Topology* section).

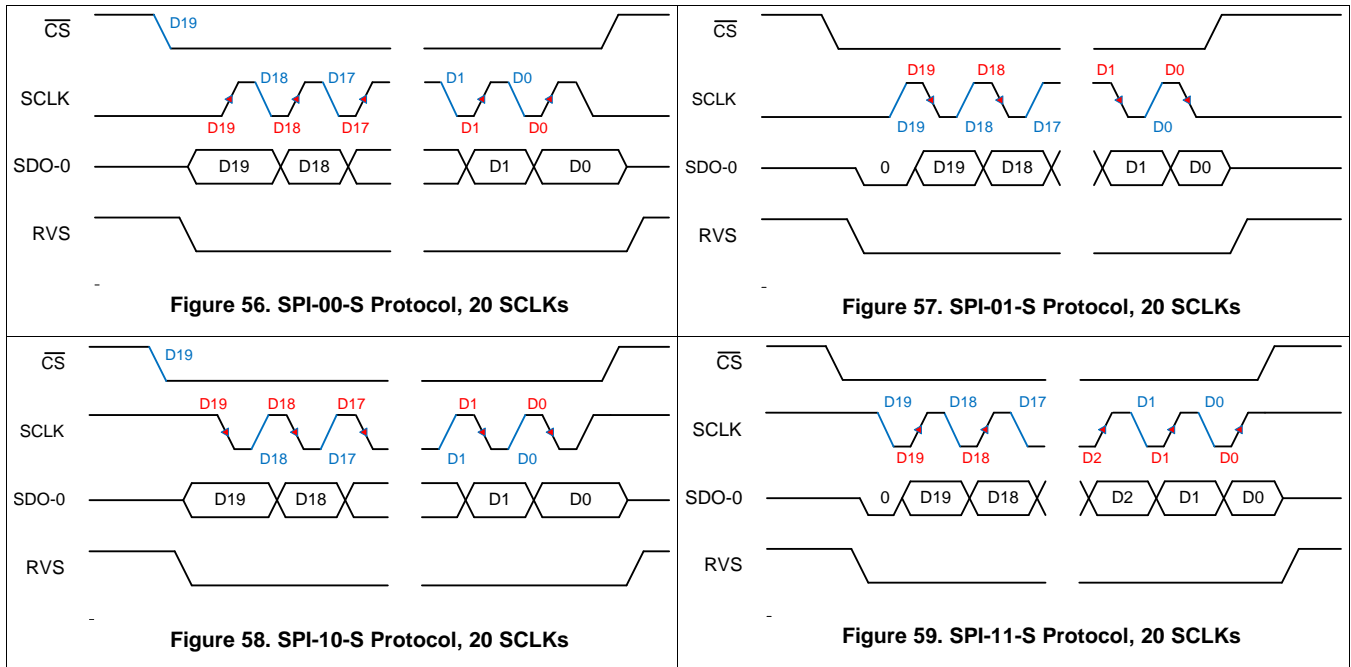

**7.5.3.2.2 SPI-Compatible Protocols with Bus Width Options**

The device provides an option to increase the SDO bus width from one bit (default, single SDO) to two bits (dual SDO) or to four bits (quad SDO) when operating with any of the four legacy, SPI-compatible protocols.

Set the SDO\_WIDTH[1:0] bits in the SDO\_CNTL register to select the SDO bus width.

In dual SDO mode (SDO\_WIDTH[1:0] = 10b), two bits of data are launched on the two SDO pins (SDO-0 and SDO-1) on every SCLK launch edge.

In quad SDO mode (SDO\_WIDTH[1:0] = 11b), four bits of data are launched on the four SDO pins (SDO-0, SDO-1, SDO-2, and SDO-3) on every SCLK launch edge.

The SCLK launch edge depends upon the SPI protocol selection (as shown in Table 6).

**Table 6. SPI-Compatible Protocols with Bus Width Options**

PROTOCOL	SCLK POLARITY (At CS Falling Edge)	SCLK PHASE (Capture Edge)	MSB BIT LAUNCH EDGE	SDI_CNTL	SDO_CNTL	#SCLK (Optimal Read Frame)	DIAGRAM
SPI-00-D	Low	Rising	CS falling	00h	08h	8	Figure 60
SPI-01-D	Low	Falling	First SCLK rising	01h	08h	8	Figure 61
SPI-10-D	High	Falling	CS falling	02h	08h	8	Figure 62
SPI-11-D	High	Rising	First SCLK falling	03h	08h	8	Figure 63
SPI-00-Q	Low	Rising	CS falling	00h	0Ch	4	Figure 64
SPI-01-Q	Low	Falling	First SCLK rising	01h	0Ch	4	Figure 65
SPI-10-Q	High	Falling	CS falling	02h	0Ch	4	Figure 66
SPI-11-Q	High	Rising	First SCLK falling	03h	0Ch	4	Figure 67

When using any of the SPI-compatible protocols, the RVS output remains low throughout the data transfer frame; see the *Timing Requirements: SPI-Compatible Serial Interface* table for associated timing parameters.

Figure 60 to Figure 67 illustrate how the wider data bus allows the host controller to read all 20 bits of the output data word using shorter data transfer frames. Table 6 shows the number of SCLK required in an optimal read frame for the different output protocol selections.

**NOTE**

With SDO\_CNTL[7:0] ≠ 00h, a long data transfer frame does not result in daisy-chain operation. On SDO pin(s), the 20 bits of output data word are followed by 0's.

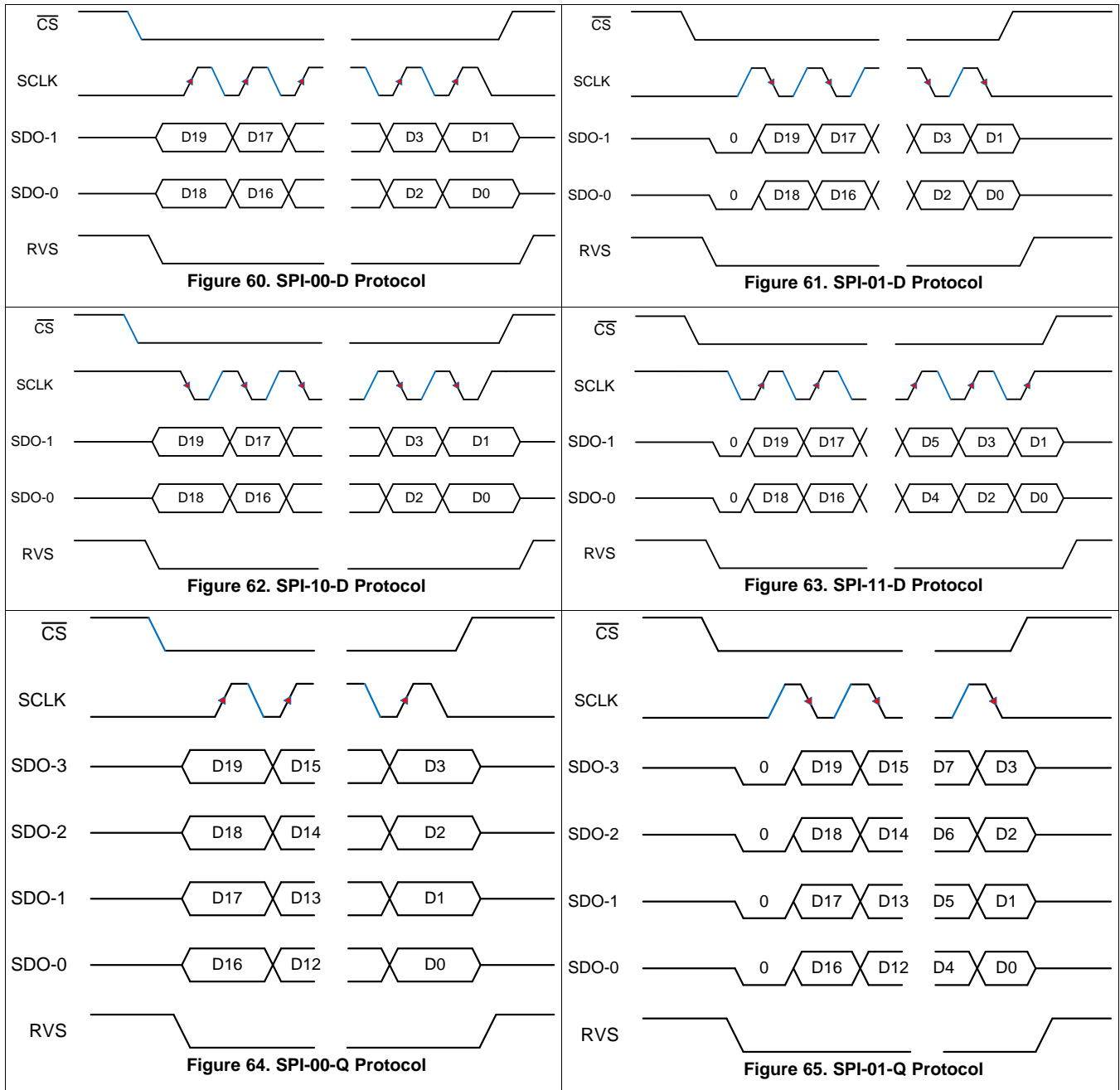

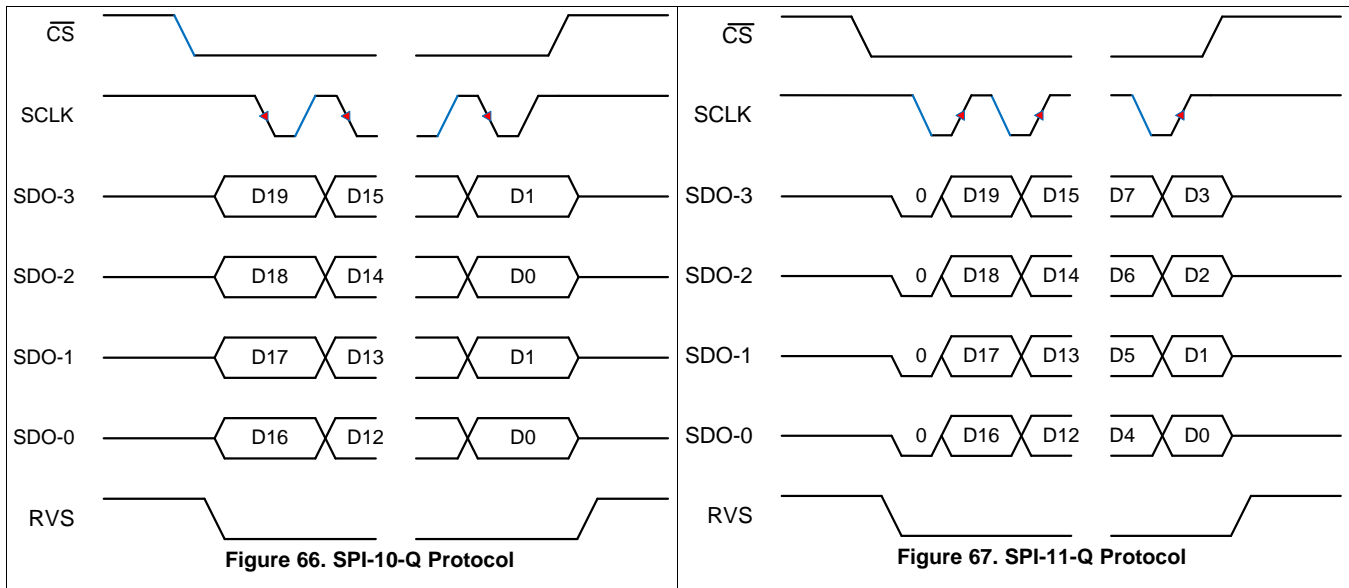

**7.5.3.2.3 Source-Synchronous (SRC) Protocols**

As described in the [Data Transfer Protocols](#) section, the multiSPI™ interface supports an ADC-Clock-Master or a *source-synchronous* mode of data transfer between the device and host controller. In this mode, the device provides an output clock that is synchronous with the output data. Furthermore, the host controller can also select the output clock source, data bus width, and data transfer rate.

**7.5.3.2.3.1 Output Clock Source Options with SRC Protocols**

In all SRC protocols, the RVS pin provides the output clock. The device allows this output clock to be synchronous to either the external clock provided on the SCLK pin or to the internal clock of the device. Furthermore, this internal clock can be divided by a factor of two or four to lower the data rates.

As shown in [Figure 68](#), set the SSYNC\_CLK\_SEL[1:0] bits in the [SDO\\_CNTL](#) register to select the output clock source.

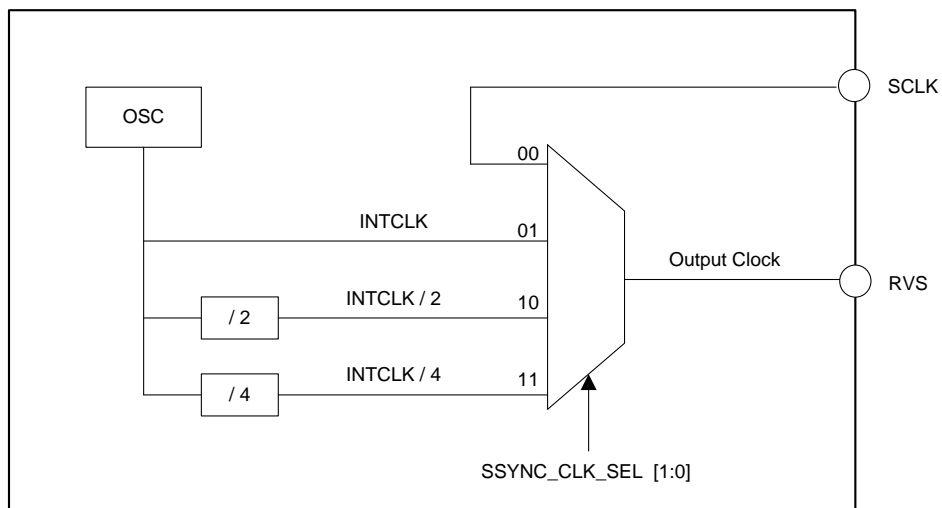

**Figure 68. Output Clock Source options with SRC Protocols**

### 7.5.3.2.3.2 Bus Width Options with SRC Protocols

The device provides an option to increase the SDO bus width from one bit (default, single SDO) to two bits (dual SDO) or to four bits (quad SDO) when operating with any of the SRC protocols. Set the SDO\_WIDTH[1:0] bits in the SDO\_CNTRL register to select the SDO bus width.

In dual SDO mode (SDO\_WIDTH[1:0] = 10b), two bits of data are launched on the two SDO pins (SDO-0 and SDO-1) on every SCLK rising edge.

In quad SDO mode (SDO\_WIDTH[1:0] = 11b), four bits of data are launched on the four SDO pins (SDO-0, SDO-1, SDO-2, and SDO-3) on every SCLK rising edge.

### 7.5.3.2.3.3 Output Data Rate Options with SRC Protocols

The device provides an option to transfer the data to the host controller at single data rate (default, SDR) or at double data rate (DDR). Set the DATA\_RATE bit in the SDO\_CNTRL register to select the data transfer rate.

In SDR mode (DATA\_RATE = 0b), the RVS pin toggles from low to high and the output data bits are launched on the SDO pins on the output clock rising edge.

In DDR mode (DATA\_RATE = 1b), the RVS pin toggles and the output data bits are launched on the SDO pins on every output clock edge, starting with the first rising edge.

The device supports all 24 combinations of output clock source, bus width, and output data rate, as shown in Table 7.

**Table 7. SRC Protocol Combinations**

PROTOCOL	OUTPUT CLOCK SOURCE	BUS WIDTH	OUTPUT DATA RATE	SDI_CNTRL	SDO_CNTRL	#OUTPUT CLOCK (Optimal Read Frame)	DIAGRAM
SRC-EXT-SS	SCLK	Single	SDR	00h, 01h, 02h, or 03h	03h	16	Figure 69
SRC-INT-SS	INTCLK	Single	SDR		43h	16	Figure 70
SRC-IB2-SS	INTCLK / 2	Single	SDR		83h	16	
SRC-IB4-SS	INTCLK / 4	Single	SDR		C3h	16	
SRC-EXT-DS	SCLK	Dual	SDR		0Bh	8	Figure 73
SRC-INT-DS	INTCLK	Dual	SDR		4Bh	8	Figure 74
SRC-IB2-DS	INTCLK / 2	Dual	SDR		8Bh	8	
SRC-IB4-DS	INTCLK / 4	Dual	SDR		CBh	8	
SRC-EXT-QS	SCLK	Quad	SDR		0Fh	4	Figure 77
SRC-INT-QS	INTCLK	Quad	SDR		4Fh	4	Figure 78
SRC-IB2-QS	INTCLK / 2	Quad	SDR		8Fh	4	
SRC-IB4-QS	INTCLK / 4	Quad	SDR		CFh	4	
SRC-EXT-SD	SCLK	Single	DDR		13h	8	Figure 71
SRC-INT-SD	INTCLK	Single	DDR		53h	8	Figure 72
SRC-IB2-SD	INTCLK / 2	Single	DDR		93h	8	
SRC-IB4-SD	INTCLK / 4	Single	DDR		D3h	8	
SRC-EXT-DD	SCLK	Dual	DDR		1Bh	4	Figure 75
SRC-INT-DD	INTCLK	Dual	DDR		5Bh	4	Figure 76
SRC-IB2-DD	INTCLK / 2	Dual	DDR		9Bh	4	
SRC-IB4-DD	INTCLK / 4	Dual	DDR		DBh	4	
SRC-EXT-QD	SCLK	Quad	DDR		1Fh	2	Figure 79
SRC-INT-QD	INTCLK	Quad	DDR		5Fh	2	Figure 80
SRC-IB2-QD	INTCLK / 2	Quad	DDR		9Fh	2	
SRC-IB4-QD	INTCLK / 4	Quad	DDR		DFh	2	

Figure 69 to Figure 80 show the details of various source synchronous protocols. Table 7 shows the number of output clocks required in an optimal read frame for the different output protocol selections.

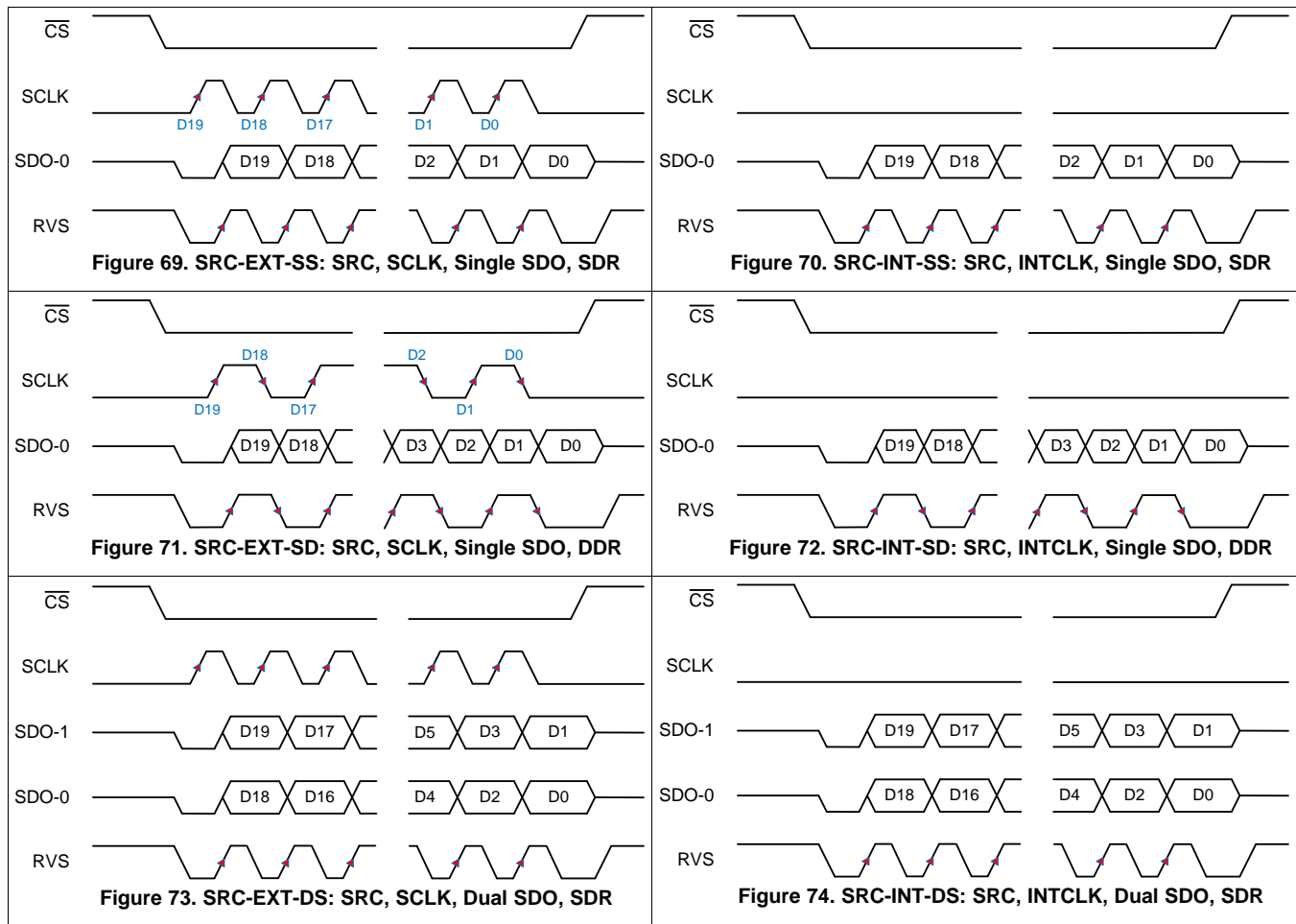

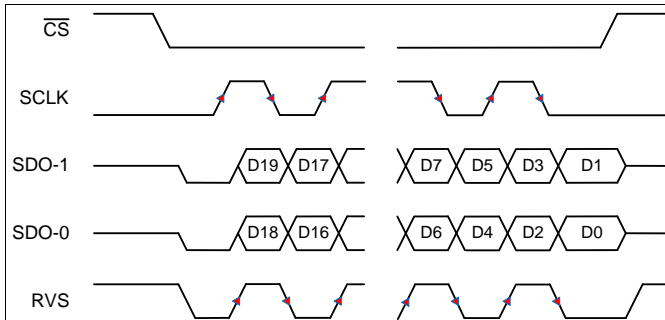

Figure 75. SRC-EXT-DD: SRC, SCLK, Dual SDO, DDR

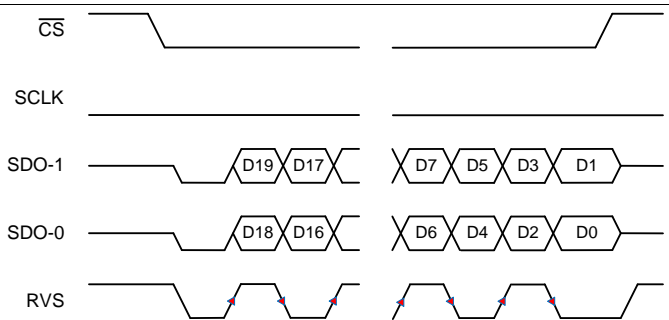

Figure 76. SRC-INT-DD: SRC, INTCLK, Dual SDO, DDR

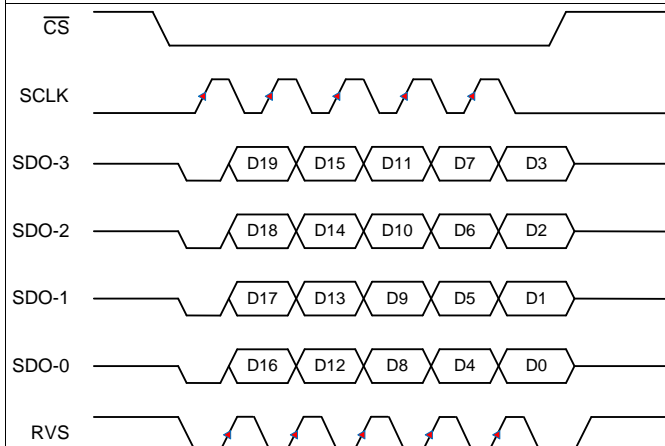

Figure 77. SRC-EXT-QS: SRC, SCLK, Quad SDO, SDR

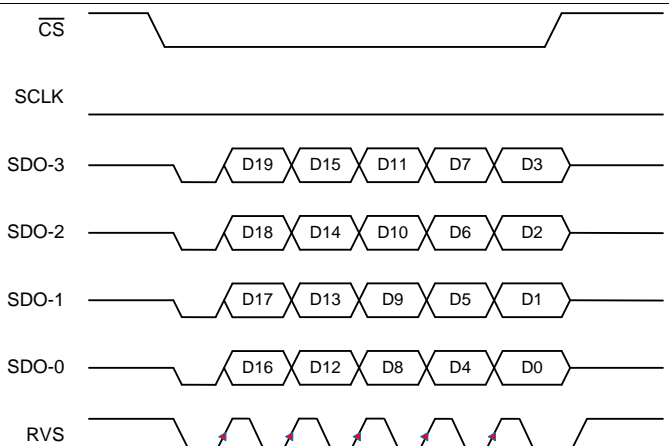

Figure 78. SRC-INT-QS: SRC, INTCLK, Quad SDO, SDR

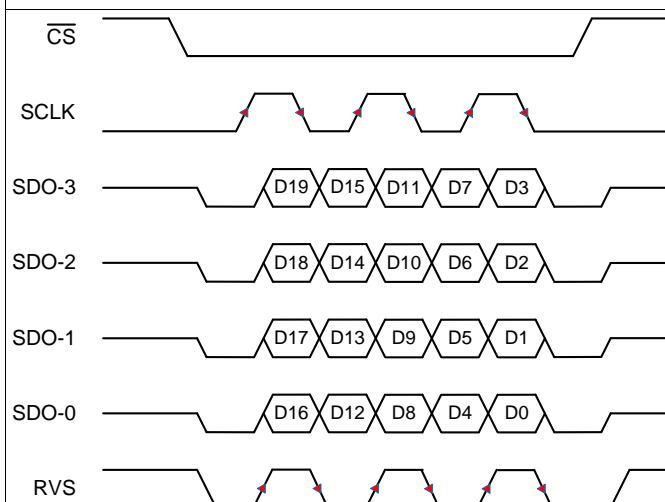

Figure 79. SRC-EXT-QD: SRC, SCLK, Quad SDO, DDR

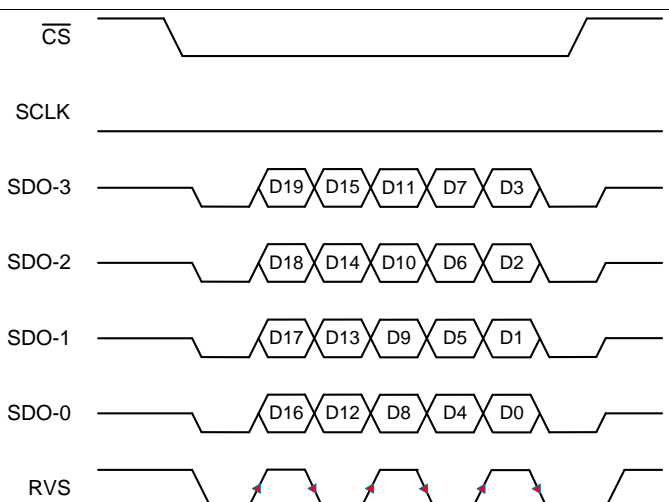

Figure 80. SRC-INT-QD: SRC, INTCLK, Quad SDO, DDR

### 7.5.4 Device Setup

The multiSPI™ interface and the device configuration registers offer multiple operation modes. This section describes how to select the hardware connection topology to meet different system requirements.

#### 7.5.4.1 Single Device: All multiSPI™ Options

Figure 81 shows the connections between a host controller and a stand-alone device to exercise all options provided by the multiSPI™ interface.

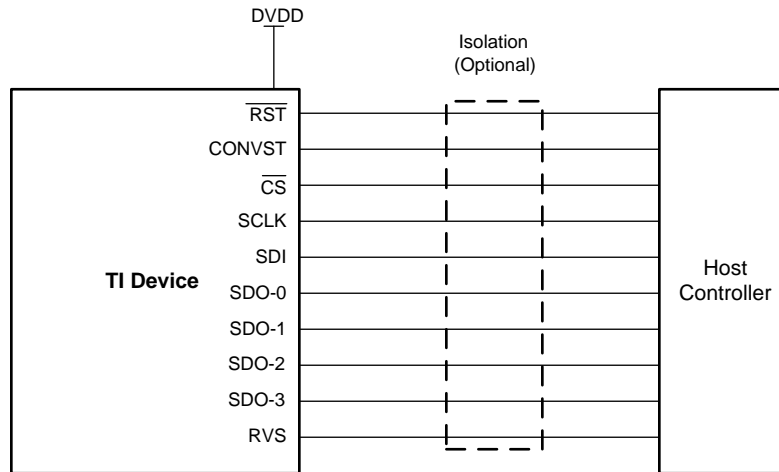

Copyright © 2016, Texas Instruments Incorporated

Figure 81. multiSPI™ Interface, All Pins

#### 7.5.4.2 Single Device: Minimum Pins for a Standard SPI Interface

Figure 82 shows the minimum-pin interface for applications using a standard SPI protocol.

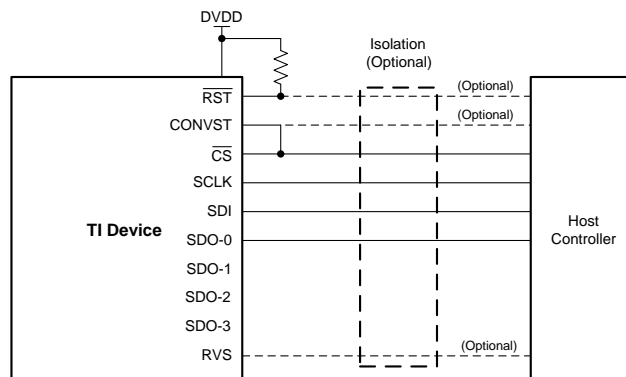

Copyright © 2016, Texas Instruments Incorporated

Figure 82. SPI Interface, Minimum Pins

The  $\overline{CS}$ , SCLK, SDI, and SDO-0 pins constitute a standard SPI port of the host controller. The CONVST pin can be tied to  $\overline{CS}$ , or can be controlled independently for additional timing flexibility. The RST pin can be tied to DVDD. The RVS pin can be monitored for timing benefits. The SDO-1, SDO-2, and SDO-3 pins have no external connections.



### 7.5.4.3 Multiple Devices: Daisy-Chain Topology

A typical connection diagram showing multiple devices in a daisy-chain topology is shown in [Figure 83](#).

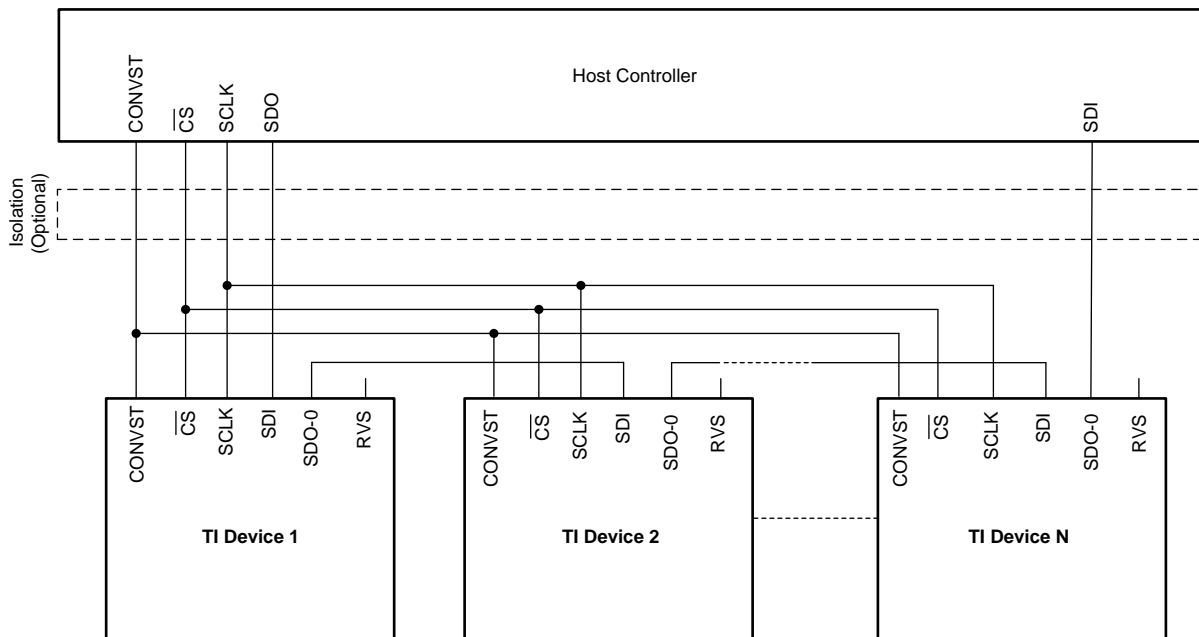

Copyright © 2016, Texas Instruments Incorporated

**Figure 83. Daisy-Chain Connection Schematic**

The CONVST,  $\overline{CS}$ , and SCLK inputs of all devices are connected together and controlled by a single CONVST,  $\overline{CS}$ , and SCLK pin of the host controller, respectively. The SDI input pin of the first device in the chain (device 1) is connected to the SDO pin of the host controller, the SDO-0 output pin of device 1 is connected to the SDI input pin of device 2, and so forth. The SDO-0 output pin of the last device in the chain (device N) is connected to the SDI pin of the host controller.

To operate multiple devices in a daisy-chain topology, the host controller must program the configuration registers in each device with identical values and must operate with any of the legacy, SPI-compatible protocols for data read and data write operations (SDO\_CNT[7:0] = 00h). With these configurations settings, the 20-bit ODR and 20-bit IDR registers in each device collapse to form a single, 20-bit unified shift register (USR) per device, as shown in [Figure 84](#).

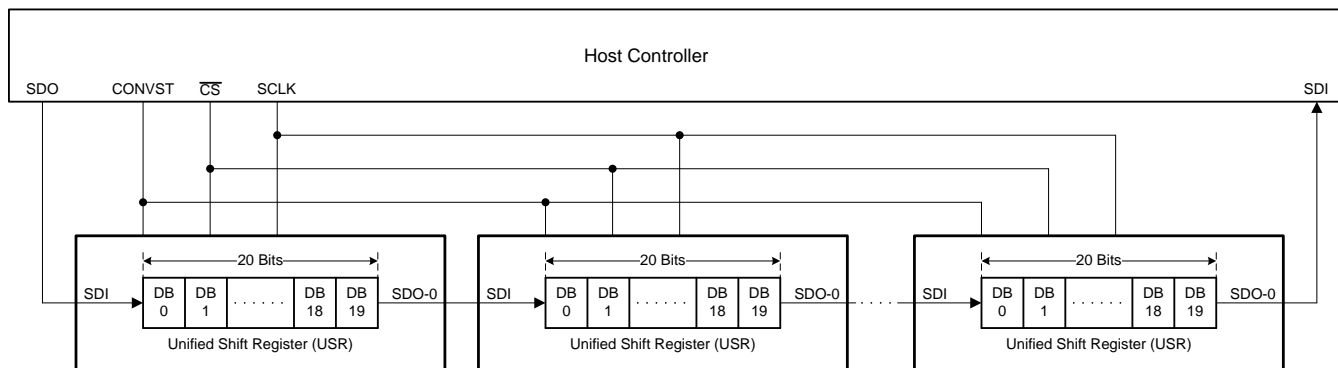

Copyright © 2016, Texas Instruments Incorporated

**Figure 84. Unified Shift Register**

All devices in the daisy-chain topology sample their analog input signals on the CONVST rising edge. The data transfer frame starts with a  $\overline{CS}$  falling edge. On each SCLK launch edge, every device in the chain shifts out the MSB of its USR on to its SDO-0 pin. On every SCLK capture edge, each device in the chain shifts in data received on its SDI pin as the LSB bit of its USR. Therefore, in a daisy-chain configuration, the host controller receives the data of device N, followed by the data of device N-1, and so forth (in MSB-first fashion). On the  $\overline{CS}$  rising edge, each device decodes the contents in its USR and takes appropriate action.

A typical timing diagram for three devices connected in daisy-chain topology and using the SPI-00-S protocol is shown in Figure 85.

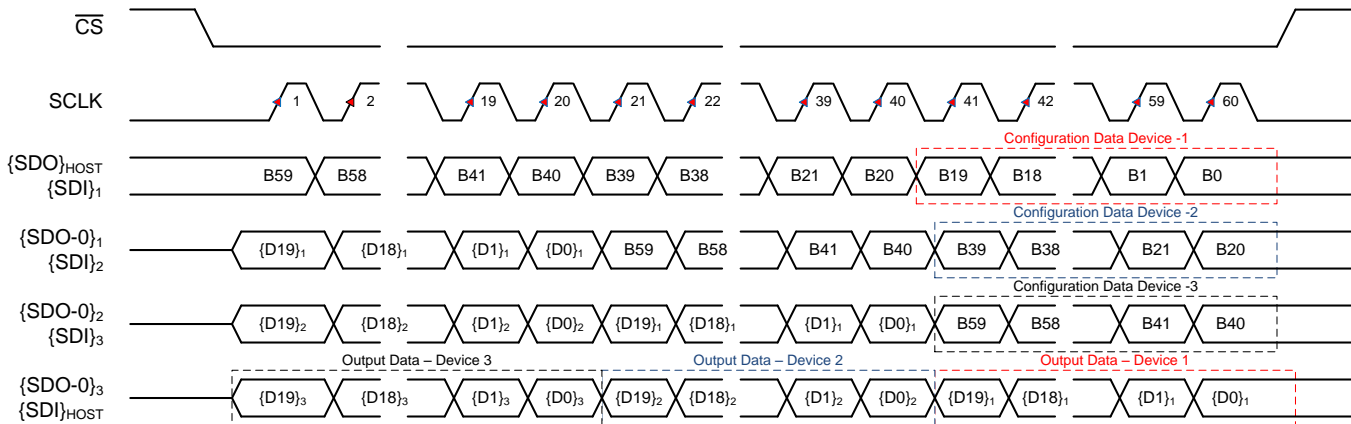

**Figure 85. Three Devices in Daisy-Chain Mode Timing Diagram**

Note that the overall throughput of the system is proportionally reduced with the number of devices connected in a daisy-chain topology.

**WARNING**

For N devices connected in daisy-chain topology, an *optimal command frame* must contain  $20 \times N$  SCLK capture edges. For a longer data transfer frame (number of SCLK in the frame  $> 20 \times N$ ), the host controller must appropriately align the configuration data for each device before bringing  $\overline{CS}$  high. A shorter data transfer frame (number of SCLK in the frame  $< 20 \times N$ ) can result in an erroneous device configuration, and *must be avoided*.

### 7.5.4.4 Multiple Devices: Star Topology

A typical connection diagram showing multiple devices in the star topology is shown in Figure 86. The CONVST, SDI, and SCLK inputs of all devices are connected together and are controlled by a single CONVST, SDO, and SCLK pin of the host controller, respectively. Similarly, the SDO output pin of all devices are tied together and connected to the a single SDI input pin of the host controller. The  $\overline{\text{CS}}$  input pin of each device is individually controlled by separate  $\overline{\text{CS}}$  control lines from the host controller.

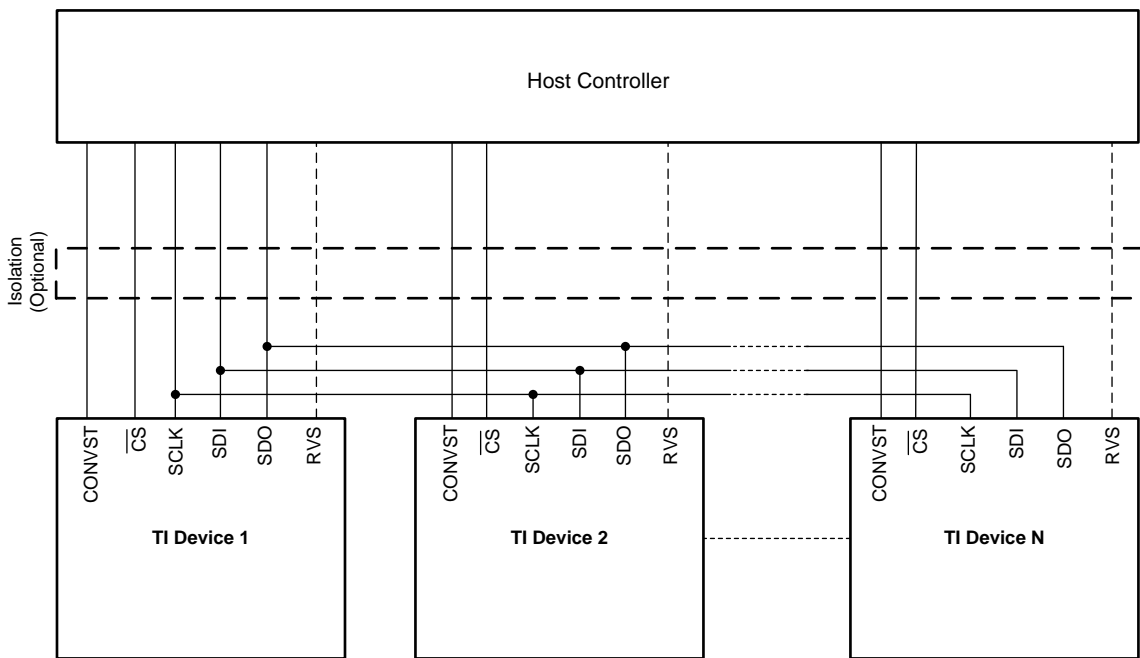

Copyright © 2016, Texas Instruments Incorporated

Figure 86. Star Topology Connection

The timing diagram for N devices connected in the star topology is shown in Figure 87. In order to avoid any conflict related to multiple devices driving the SDO line at the same time, ensure that the host controller pulls down the  $\overline{\text{CS}}$  signal for only one device at any particular time.

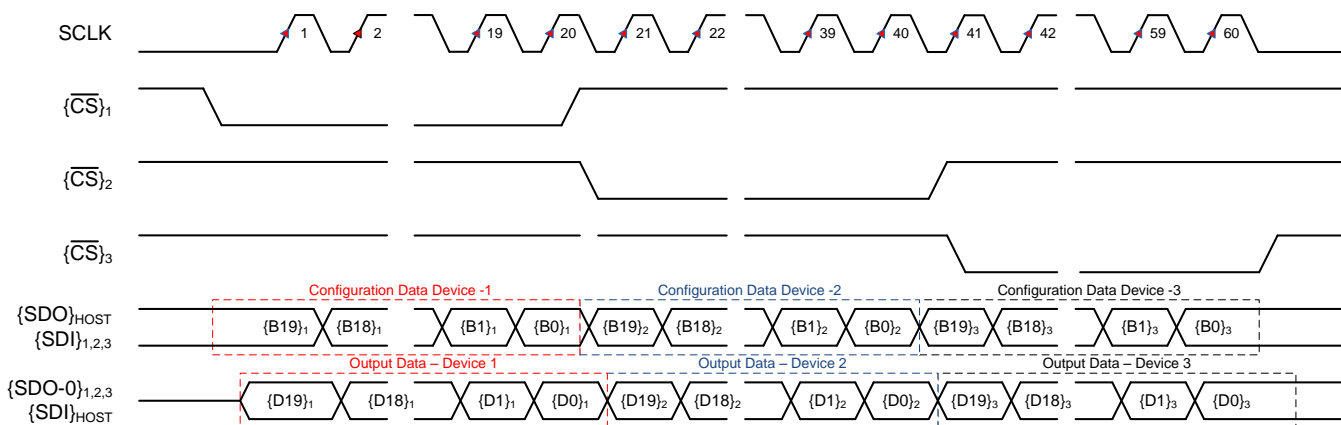

Figure 87. Three Devices Connected in Star Connection Timing Diagram

## 7.6 Register Maps

### 7.6.1 Device Configuration and Register Maps

The device features four configuration registers, mapped as described in [Table 8](#).

**Table 8. Configuration Registers Mapping**

ADDRESS	REGISTER NAME	REGISTER FUNCTION	SECTION
010h	PD_CNTL	Low-power modes control register	<a href="#">PD Control</a>
014h	SDI_CNTL	SDI input protocol selection register	<a href="#">SDI Control</a>
018h	SDO_CNTL	SDO output protocol selection register	<a href="#">SDO Control</a>
01Ch	DATA_CNTL	Output data word configuration register	<a href="#">DATA Control</a>

#### 7.6.1.1 PD\_CNTL Register (address = 010h)

This register controls the low-power modes offered by the device and is protected using a key.

Any writes to the PD\_CNTL register must be preceded by a write operation with the register address set to 011h and the register data set to 69h.

**Figure 88. PD\_CNTL Register**

7	6	5	4	3	2	1	0
0	0	0	0	0	0	NAP_EN	PDWN
R-0b	R-0b	R-0b	R-0b	R-0b	R-0b	R/W-0b	R/W-0b

LEGEND: R/W = Read/Write; R = Read only; -n = value after reset

**Table 9. PD\_CNTL Register Field Descriptions**

Bit	Field	Type	Reset	Description
7-2	0	R	000000b	Reserved bits. Reads return 000000b.
1	NAP_EN	R/W	0b	This bit enables NAP mode for the device. 0b = NAP mode is disabled 1b = NAP mode is enabled
0	PDWN	R/W	0b	This bit outputs the device in power-down mode. 0b = Device is powered up 1b = Device is powered down

#### 7.6.1.2 SDI\_CNTL Register (address = 014h)

This register configures the protocol used for writing data into the device.

**Figure 89. SDI\_CNTL Register**

7	6	5	4	3	2	1	0
0	0	0	0	0	0	SDI_MODE[1:0]	
R-0b	R-0b	R-0b	R-0b	R-0b	R-0b	R/W-0b	

LEGEND: R/W = Read/Write; R = Read only; -n = value after reset

**Table 10. SDI\_CNTL Register Field Descriptions**

Bit	Field	Type	Reset	Description
7-2	0	R	000000b	Reserved bits. Reads return 000000b.
1-0	SDI_MODE[1:0]	R/W	00b	These bits select the protocol for writing data into the device. 00b = Standard SPI with CPOL = 0 and CPHASE = 0 01b = Standard SPI with CPOL = 0 and CPHASE = 1 10b = Standard SPI with CPOL = 1 and CPHASE = 0 11b = Standard SPI with CPOL = 1 and CPHASE = 1

### 7.6.1.3 SDO\_CNTL Register (address = 018h)

This register configures the protocol for reading data from the device.

**Figure 90. SDO\_CNTL Register**

7	6	5	4	3	2	1	0
SSYNC_CLK_SEL[1:0]		0	DATA_RATE	SDO_WIDTH[1:0]		SDO_MODE[1:0]	
R/W-00b		R-0b	R/W-0b	R/W-00b		R/W-00b	

LEGEND: R/W = Read/Write; R = Read only; -n = value after reset

**Table 11. SDO\_CNTL Register Field Descriptions**

Bit	Field	Type	Reset	Description
7-6	SSYNC_CLK_SEL[1:0]	R/W	00b	These bits select the source and frequency of the clock for the source-synchronous data transmission and are valid only if SDO_MODE[1:0] = 11b. 00b = External SCLK echo 01b = Internal clock (INTCLK) 10b = Internal clock / 2 (INTCLK / 2) 11b = Internal clock / 4 (INTCLK / 4)
5	0	R	0b	This bit must be always set to 0.
4	DATA_RATE	R/W	0b	This bit is ignored if SDO_MODE[1:0] = 00b. When SDO_MODE[1:0] = 11b: 0b = SDOs are updated at single data rate (SDR) with respect to the output clock 1b = SDOs are updated at double data rate (DDR) with respect to the output clock
3-2	SDO_WIDTH[1:0]	R/W	00b	These bits set the width of the output bus. 0xb = Data are output only on SDO-0 10b = Data are output only on SDO-0 and SDO-1 11b = Data are output on SDO-0, SDO-1, SDO-2, and SDO-3
1-0	SDO_MODE[1:0]	R/W	00b	These bits select the protocol for reading data from the device. 00b = SDO follows the same SPI protocol as SDI; see the <a href="#">SDI_CNTL register</a> 01b = Invalid configuration, not supported by the device 10b = Invalid configuration, not supported by the device 11b = SDO follows the source-synchronous protocol

**7.6.1.4 DATA\_CNTL Register (address = 01Ch)**

This register configures the contents of the 20-bit output data word (D[19:0]).

**Figure 91. DATA\_CNTL Register**

7	6	5	4	3	2	1	0
0	0	FPAR_LOC 0		PAR_EN	DATA_PATN[2:0]		
R-0b	R-0b	R/W-00b		R/W-0b	R/W-000b		

LEGEND: R/W = Read/Write; R = Read only; -n = value after reset

**Table 12. DATA\_CNTL Register Field Descriptions**

Bit	Field	Type	Reset	Description
7-6	0	R	00b	Reserved bits. Reads return 00b.
5-4	FPAR_LOC[1:0]	R/W	00b	These bits control the data span for calculating the FTPAR bit (bit D[0] in the output data word). 00b = D[2] reflects even parity calculated for 4 MSB bits 01b = D[2] reflects even parity calculated for 8 MSB bits 10b = D[2] reflects even parity calculated for 12 MSB bits 11b = D[2] reflects even parity calculated for all 16 bits; that is, same as FLPAR
3	PAR_EN	R/W	0b	0b = Output data does not contain any parity information D[3] = 0 D[2] = 0 1b = Parity information is appended to the LSB of the output data D[3] = Even parity calculated on bits D[19:4] D[2] = Even parity computed on the selected number of MSB bits of D[19:4] as per the FPAR_LOC[1:0] setting See <a href="#">Figure 45</a> for further details of parity computation.
2-0	DATA_PATN[2:0]	R/W	000b	These bits control bits D[19:4] of the output data word. 0xxb = 16-bit conversion output 100b = All 0s 101b = All 1s 110b = Alternating 0s and 1s (that is, 5555h) 111b = Alternating 00s and 11s (that is, 3333h) See <a href="#">Figure 46</a> for more details.

## 8 Application and Implementation

### NOTE

Information in the following applications sections is not part of the TI component specification, and TI does not warrant its accuracy or completeness. TI's customers are responsible for determining suitability of components for their purposes. Customers should validate and test their design implementation to confirm system functionality.

### 8.1 Application Information

The two primary circuits required to maximize the performance of a high-precision, successive approximation register (SAR), analog-to-digital converter (ADC) are the input driver and the reference driver circuits. This section details some general principles for designing these circuits, followed by an application circuit designed using the ADS9120.

#### 8.1.1 ADC Input Driver

The input driver circuit for a high-precision ADC mainly consists of two parts: a driving amplifier and a fly-wheel RC filter. The amplifier is used for signal conditioning of the input signal and its low output impedance provides a buffer between the signal source and the switched capacitor inputs of the ADC. The RC filter helps attenuate the sampling charge injection from the switched-capacitor input stage of the ADC and functions as an antialiasing filter to band-limit the wideband noise contributed by the front-end circuit. Careful design of the front-end circuit is critical to meet the linearity and noise performance of the ADS9120.

#### 8.1.2 Input Amplifier Selection

Selection criteria for the input amplifiers is highly dependent on the input signal type as well as the performance goals of the data acquisition system. Some key amplifier specifications to consider when selecting an appropriate amplifier to drive the inputs of the ADC are:

- *Small-signal bandwidth.* Select the small-signal bandwidth of the input amplifiers to be as high as possible after meeting the power budget of the system. Higher bandwidth reduces the closed-loop output impedance of the amplifier, thus allowing the amplifier to more easily drive the low cutoff frequency RC filter (see the [Antialiasing Filter](#) section) at the inputs of the ADC. Higher bandwidth also minimizes the harmonic distortion at higher input frequencies. In order to maintain the overall stability of the input driver circuit, select the amplifier with Unity Gain Bandwidth (UGB) as described in [Equation 14](#):

$$UGB \geq 4 \times \left( \frac{1}{2\pi \times R_{FLT} \times C_{FLT}} \right) \quad (14)$$

- *Noise.* Noise contribution of the front-end amplifiers must be as low as possible to prevent any degradation in SNR performance of the system. Generally, to ensure that the noise performance of the data acquisition system is not limited by the front-end circuit, the total noise contribution from the front-end circuit must be kept below 20% of the input-referred noise of the ADC. Noise from the input driver circuit is band-limited by designing a low cutoff frequency RC filter, as explained in [Equation 15](#).

$$N_G \times \sqrt{2} \times \sqrt{\left( \frac{V_{1/f\_AMP\_PP}}{6.6} \right)^2 + e_{n\_RMS}^2 \times \frac{\pi}{2} \times f_{-3dB}} \leq \frac{1}{5} \times \frac{V_{REF}}{\sqrt{2}} \times 10^{-\left( \frac{SNR(dB)}{20} \right)}$$

where:

- $V_{1/f\_AMP\_PP}$  is the peak-to-peak flicker noise in  $\mu V$ ,
  - $e_{n\_RMS}$  is the amplifier broadband noise density in  $nV/\sqrt{Hz}$ ,
  - $f_{-3dB}$  is the 3-dB bandwidth of the RC filter, and
  - $N_G$  is the noise gain of the front-end circuit that is equal to 1 in a buffer configuration. (15)
- *Distortion.* Both the ADC and the input driver introduce distortion in a data acquisition block. To ensure that the distortion performance of the data acquisition system is not limited by the front-end circuit, the distortion of the input driver must be at least 10 dB lower than the distortion of the ADC, as shown in [Equation 16](#).

$$THD_{AMP} \leq THD_{ADC} - 10 \text{ (dB)} \quad (16)$$

## Application Information (continued)

- Settling Time.** For dc signals with fast transients that are common in a multiplexed application, the input signal must settle within an 16-bit accuracy at the device inputs during the acquisition time window. This condition is critical to maintain the overall linearity performance of the ADC. Typically, the amplifier data sheets specify the output settling performance only up to 0.1% to 0.001%, which may not be sufficient for the desired 16-bit accuracy. Therefore, always verify the settling behavior of the input driver by TINA™-SPICE simulations before selecting the amplifier.

### 8.1.3 Antialiasing Filter

Converting analog-to-digital signals requires sampling an input signal at a constant rate. Any higher-frequency content in the input signal beyond half the sampling frequency is digitized and folded back into the low-frequency spectrum. This process is called *aliasing*. Therefore, an analog, antialiasing filter must be used to remove the harmonic content from the input signal before being sampled by the ADC. An antialiasing filter is designed as a low-pass, RC filter, where the 3-dB bandwidth is optimized based on specific application requirements. For dc signals with fast transients (including multiplexed input signals), a high-bandwidth filter is designed to allow accurately settling the signal at the inputs of the ADC during the small acquisition time window. For ac signals, keep the filter bandwidth low to band-limit the noise fed into the input of the ADC, thereby increasing the signal-to-noise ratio (SNR) of the system.

Besides filtering the noise from the front-end drive circuitry, the RC filter also helps attenuate the sampling charge injection from the switched-capacitor input stage of the ADC. A filter capacitor,  $C_{FLT}$ , is connected from each input pin of the ADC to the ground (as shown in Figure 92). This capacitor helps reduce the sampling charge injection and provides a charge bucket to quickly charge the internal sample-and-hold capacitors during the acquisition process. Generally, the value of this capacitor must be at least 15 times the specified value of the ADC sampling capacitance. For the ADS9120, the input sampling capacitance is equal to 60 pF, thus it is recommended to keep  $C_{FLT}$  greater than 900 pF. The capacitor must be a COG- or NPO-type because these capacitor types have a high-Q, low-temperature coefficient, and stable electrical characteristics under varying voltages, frequency, and time.

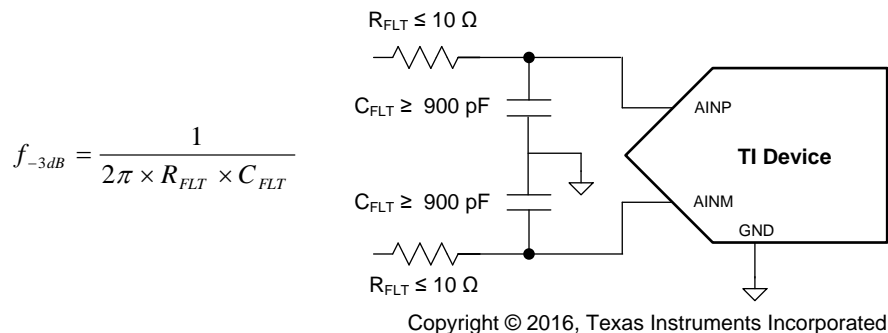

**Figure 92. Antialiasing Filter Configuration**

Note that driving capacitive loads can degrade the phase margin of the input amplifiers, thus making the amplifier marginally unstable. To avoid amplifier stability issues, series isolation resistors ( $R_{FLT}$ ) are used at the output of the amplifiers. A higher value of  $R_{FLT}$  is helpful from the amplifier stability perspective, but adds distortion as a result of interactions with the nonlinear input impedance of the ADC. Distortion increases with source impedance, input signal frequency, and input signal amplitude. Therefore, the selection of  $R_{FLT}$  requires balancing the stability and distortion of the design. For the ADS9120, limiting the value of  $R_{FLT}$  to a maximum of 10-Ω is recommended in order to avoid any significant degradation in linearity performance. The tolerance of the selected resistors must be kept less than 1% to keep the inputs balanced.

The driver amplifier must be selected such that its closed-loop output impedance is at least 5X less than the  $R_{FLT}$ .



## Application Information (continued)

### 8.1.4 ADC Reference Driver

The external reference source to the ADS9120 must provide low-drift and very accurate voltage for the ADC reference input and support the dynamic charge requirements without affecting the noise and linearity performance of the device. The output broadband noise of most references can be in the order of a few hundred  $\mu\text{V}_{\text{RMS}}$ . Therefore, to prevent any degradation in the noise performance of the ADC, the output of the voltage reference must be appropriately filtered by using a low-pass filter with a cutoff frequency of a few hundred hertz.

After band-limiting the noise of the reference circuit, the next important step is to design a reference buffer that can drive the dynamic load posed by the reference input of the ADC. The reference buffer must regulate the voltage at the reference pin such that the value of  $V_{\text{REF}}$  stays within the 1-LSB error at the start of each conversion. This condition necessitates the use of a large capacitor, CBUF\_FLT (see [Figure 38](#)), between each pair of REFP and REFM pins for regulating the voltage at the reference input of the ADC. The effective capacitance of any large capacitor reduces with the applied voltage based on the voltage rating and type. Using X7R-type capacitors is strongly recommended.

The amplifier selected as the reference driver must have an extremely low offset and temperature drift with a low output impedance to drive the capacitor at the ADC reference pins without any stability issues.

## 8.2 Typical Application

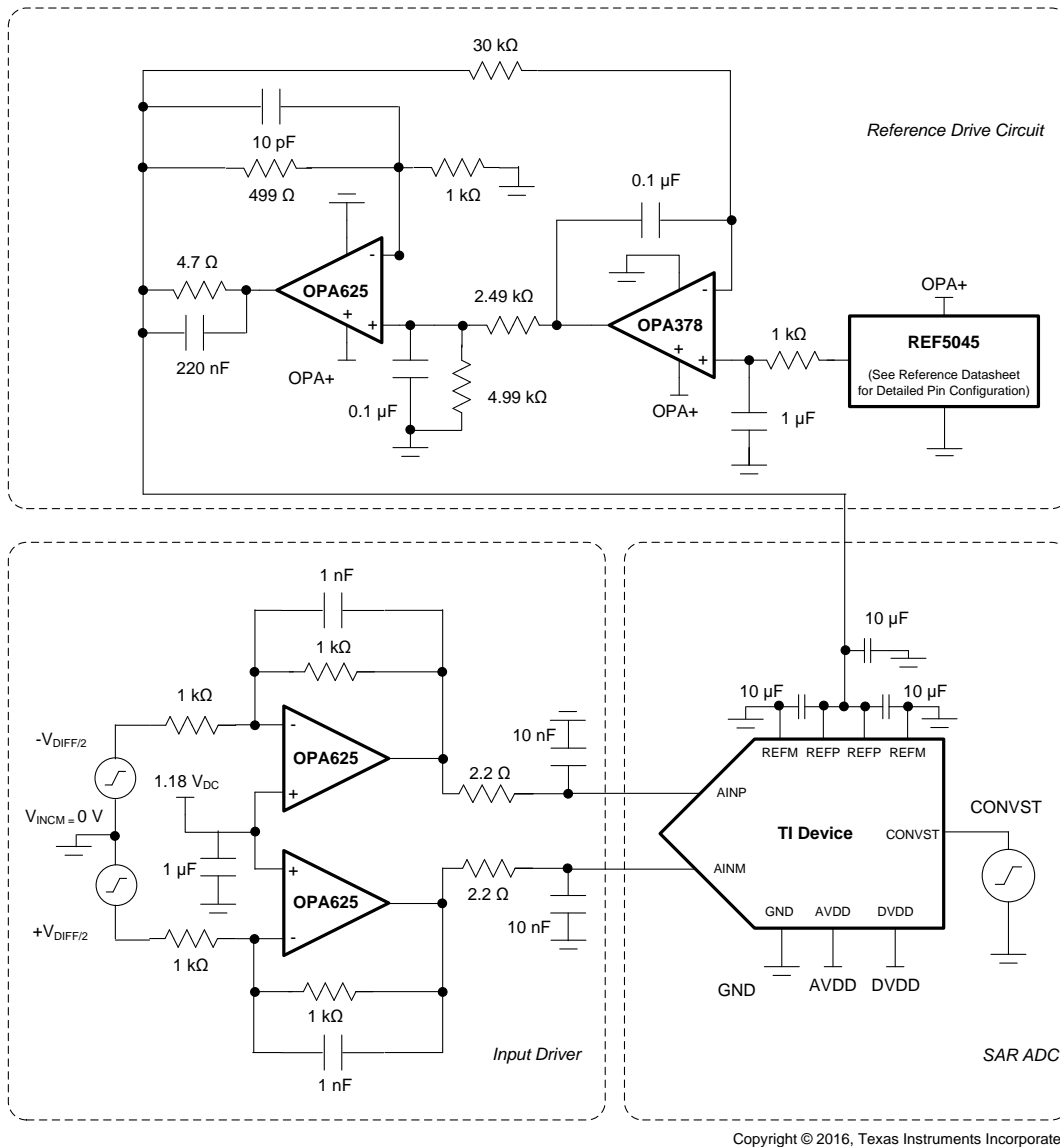

**Figure 93. Differential Input DAQ Circuit for Lowest Distortion and Noise at 2.5 MSPS**

### 8.2.1 Design Requirements

Design an application circuit optimized for using the ADS9120 to achieve:

- > 95-dB SNR, < -118-dB THD
- ±0.5-LSB linearity and
- Maximum-specified throughput of 2.5 MSPS

## Typical Application (continued)

### 8.2.2 Detailed Design Procedure

The application circuits are illustrated in [Figure 93](#). For simplicity, power-supply decoupling capacitors are not shown in these circuit diagrams; see the [Power-Supply Recommendations](#) section for suggested guidelines.

The input signal is processed through the [OPA625](#) (a high-bandwidth, low-distortion, high-precision amplifier in an inverting gain configuration) and a low-pass RC filter before being fed into the ADC. Generally, the distortion from the input driver must be at least 10 dB less than the ADC distortion. The distortion resulting from variation in the common-mode signal is eliminated by using the OPA625 in an inverting gain configuration. The low-power OPA625 as an input driver provides exceptional ac performance because of its extremely low-distortion and high-bandwidth specifications. To exercise the complete dynamic range of the ADS9120, the common-mode voltage at the ADS9120 inputs is established at a value of 2.25 V ( $4.5\text{ V} / 2$ ) by using the noninverting pins of the OPA625 amplifiers.

In addition, the components of the antialiasing filter are such that the noise from the front-end circuit is kept low without adding distortion to the input signal.

The reference driver circuit, illustrated in [Figure 93](#), generates a voltage of  $4.5\text{ V}_{\text{DC}}$  using a single 5-V supply. This circuit is suitable to drive the reference of the ADS9120 at higher sampling rates up to 2.5 MSPS. The reference voltage of 4.5 V in this design is generated by the high-precision, low-noise [REF5045](#) circuit. The output broadband noise of the reference is heavily filtered by a low-pass filter with a 3-dB cutoff frequency of 160 Hz.

The reference buffer is designed with the OPA625 and [OPA378](#) in a composite architecture to achieve superior dc and ac performance at a reduced power consumption, compared to using a single high-performance amplifier. The OPA625 is a high-bandwidth amplifier with a very low open-loop output impedance of  $1\ \Omega$  up to a frequency of 1 MHz. The low open-loop output impedance makes the OPA625 a good choice for driving a high capacitive load to regulate the voltage at the reference input of the ADC. The relatively higher offset and drift specifications of the OPA625 are corrected by using a dc-correcting amplifier (the OPA378) inside the feedback loop. The composite scheme inherits the extremely low offset and temperature drift specifications of the OPA378.

### 8.2.3 Application Curves

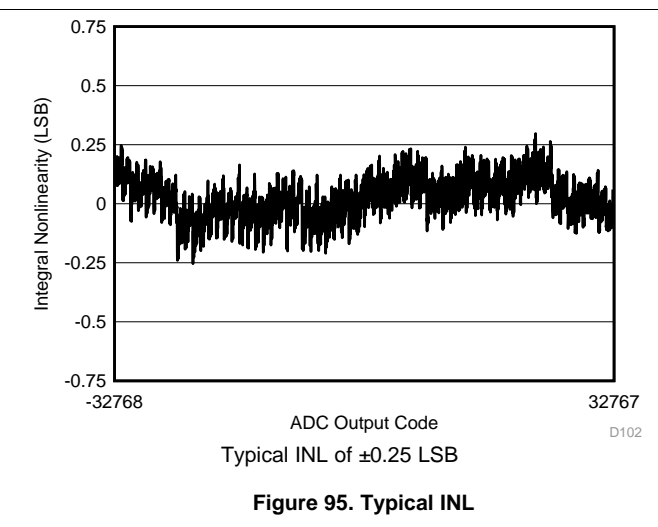
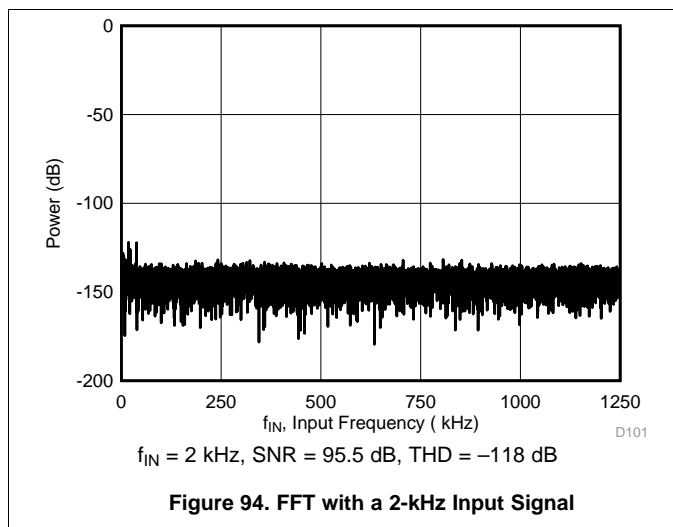

## 9 Power-Supply Recommendations

The device has two separate power supplies: AVDD and DVDD. The internal circuits of the device operate on AVDD; DVDD is used for the digital interface. AVDD and DVDD can be independently set to any value within the permissible range.

### 9.1 Power-Supply Decoupling

The AVDD and DVDD supply pins cannot share the same decoupling capacitor. As shown in Figure 96, separate 1- $\mu$ F ceramic capacitors are recommended. These capacitors avoid digital and analog supply crosstalk resulting from dynamic currents during conversion and data transfer.

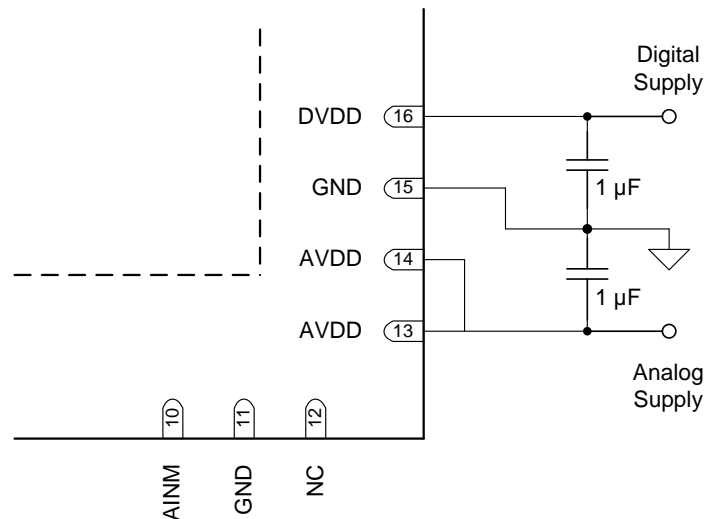

Figure 96. Supply Decoupling

### 9.2 Power Saving

In normal mode of operation, the device does not power down between conversions, and therefore achieves a high throughput of 2.5 MSPS. However, the device offers two programmable low-power modes (NAP and PD) to reduce power consumption when the device is operated at lower throughput rates. Figure 97 shows comparative power consumption between the different modes of the device.

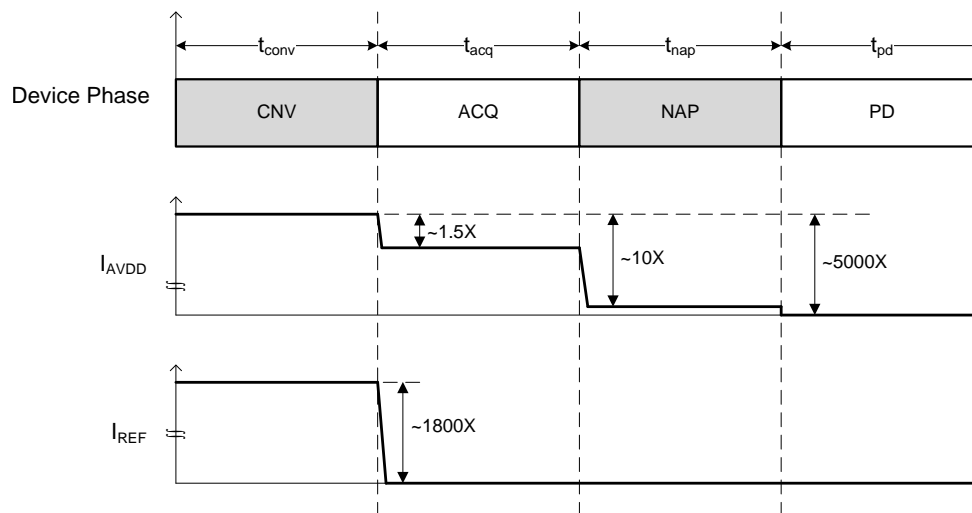

Figure 97. Power Consumption in Different Operating Modes

## Power Saving (continued)

### 9.2.1 NAP Mode

In NAP mode, some of the internal blocks of the device power down to reduce power consumption in the ACQ state.

To enable NAP mode, set the NAP\_EN bit in the PD\_CNTL register. To exercise NAP mode, keep the CONVST pin high at the end of conversion process. The device then enters NAP mode at the end of conversion and continues in NAP mode until the CONVST pin is held high.

A CONVST falling edge brings the device out of NAP mode; however, the host controller can initiate a new conversion (CONVST rising edge) only after the  $t_{nap\_wkup}$  time has elapsed.

Figure 98 shows a typical conversion cycle with NAP mode enabled (NAP\_EN = 1b).

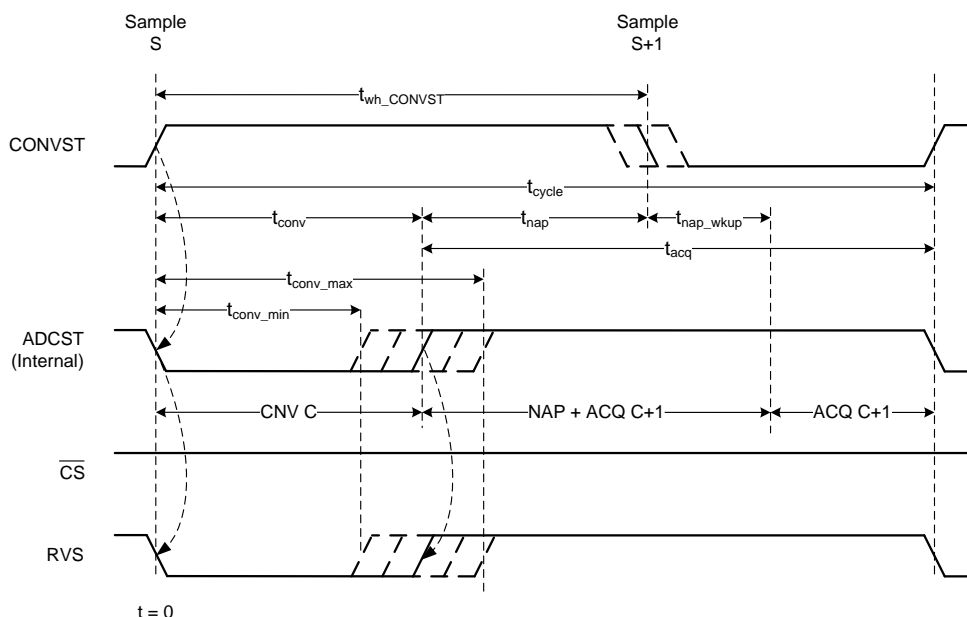

Figure 98. NAP Enabled Conversion Cycle

The cycle time is given by Equation 17.

$$t_{cycle} = t_{conv} + t_{nap} + t_{nap\_wkup} \quad (17)$$

At lower throughputs, cycle time ( $t_{cycle}$ ) increases but the conversion time ( $t_{conv}$ ) remains constant, and therefore the device spends more time in NAP mode, thus giving power scaling with throughput as shown in Figure 99.

## Power Saving (continued)

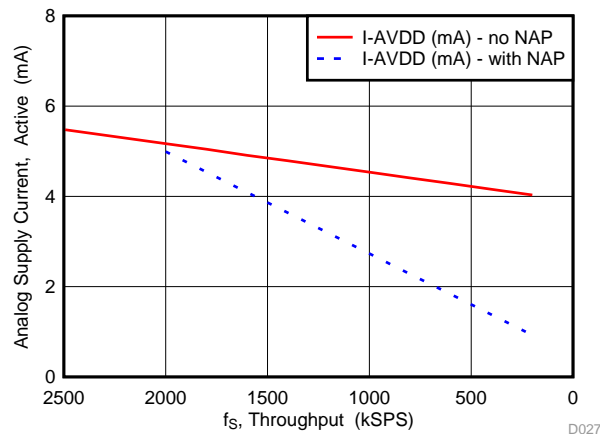

**Figure 99. Power Scaling with Throughput with NAP Mode**

### 9.2.2 PD Mode

The device also features a deep power-down mode (PD) to reduce the power consumption at very low throughput rates.

To enter PD mode:

1. Write 069h to address 011h to unlock the [PD\\_CNTL register](#).
2. Set the PDWN bit in the [PD\\_CNTL register](#). The device enters PD mode on the  $\overline{CS}$  rising edge.

In PD mode, all analog blocks within the device are powered down. All register contents are retained and the interface remains active.

To exit PD mode:

1. Reset the PDWN bit in the [PD\\_CNTL register](#).
2. The RVS pin goes high, indicating that the device has processed the command and has started coming out of PD mode. However, the host controller must wait for the  $t_{PWRUP}$  time to elapse before initiating a new conversion.

## 10 Layout

### 10.1 Layout Guidelines

This section provides some recommended layout guidelines for achieving optimum performance with the ADS9120 device.

#### 10.1.1 Signal Path

As illustrated in [Figure 100](#), the analog input and reference signals are routed in opposite directions to the digital connections. This arrangement prevents noise generated by digital switching activity from coupling to sensitive analog signals.

#### 10.1.2 Grounding and PCB Stack-Up

Low inductance grounding is critical for achieving optimum performance. Grounding inductance is kept below 1 nH with 15-mil grounding vias and a printed circuit board (PCB) layout design that has at least four layers. Place all critical components of the signal chain on the top layer with a solid analog ground from subsequent inner layers to minimize via length to ground.

Pins 11 and 15 of the ADS9120 can be easily grounded with very low inductance by placing at least four 8-mil grounding vias at the ADS9120 thermal pad. Afterwards, pins 11 and 15 can be connected directly to the grounded thermal pad.

## Layout Guidelines (continued)

### 10.1.3 Decoupling of Power Supplies

Place the AVDD and DVDD supply decoupling capacitors within 20 mil from the supply pins and use a 15-mil via to ground from each capacitor. Avoid placing vias between any supply pin and its decoupling capacitor.

### 10.1.4 Reference Decoupling

Dynamic currents are also present at the REFP and REFM pins during the conversion phase and excellent decoupling is required to achieve optimum performance. Three 10- $\mu$ F, X7R-grade, ceramic capacitors with 10-V rating are recommended, placed as illustrated in Figure 100. Select 0603- or 0805-size capacitors to keep ESL low. The REFM pin of each pair must be connected to the decoupling capacitor before a ground via.

### 10.1.5 Differential Input Decoupling

Dynamic currents are also present at the differential analog inputs of the ADS9120. C0G- or NPO-type capacitors are required to decouple these inputs because their capacitance stays almost constant over the full input voltage range. Lower quality capacitors (such as X5R and X7R) have large capacitance changes over the full input voltage range that can cause degradation in the performance of the ADS9120.

## 10.2 Layout Example

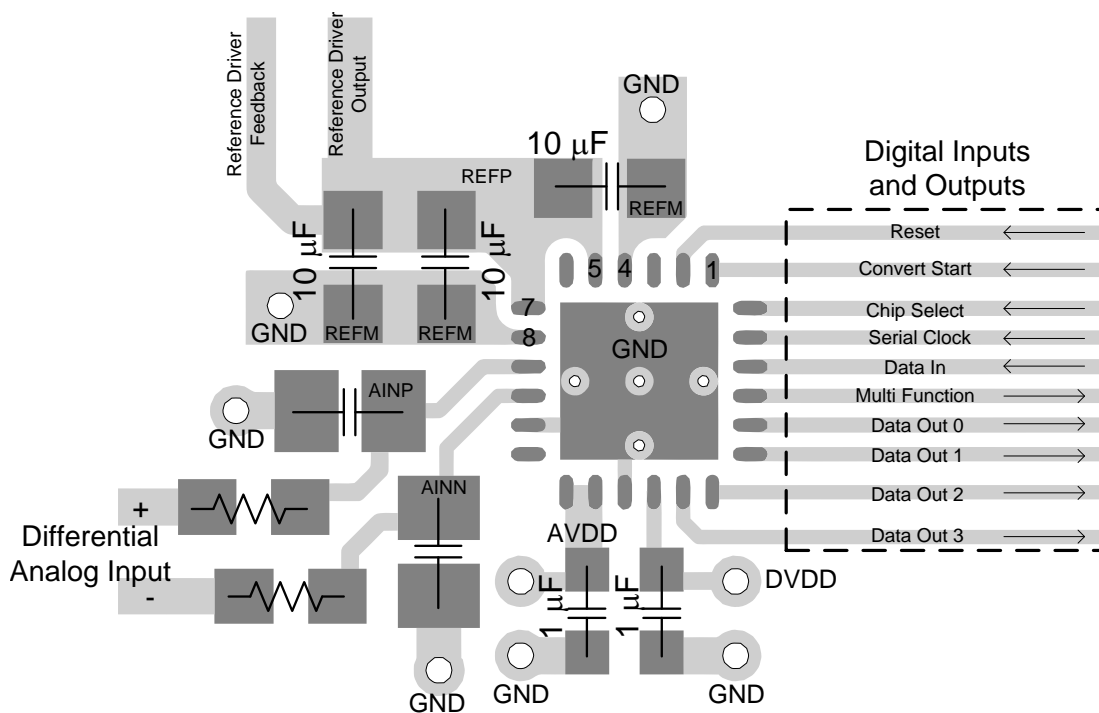

Figure 100. Recommended Layout

## 11 器件和文档支持

### 11.1 文档支持

#### 11.1.1 相关文档

相关文档如下：

- 《[ADS9120EVM-PDK 用户指南](#)》（文献编号：SBAU262）
- 《[可实现最大 SNR 和采样率的 18 位、2MSPS 隔离式数据采集参考设计](#)》（文献编号：TIDUB85）
- 《[电压基准对总谐波失真的影响](#)》（文献编号：SLYY097）
- 《[REF60xx 集成 ADC 驱动器缓冲器的高精度电压基准](#)》（文献编号：SBOS708）
- 《[OPAx625 高带宽、高精度、低 THD+N、16 位和 18 位 ADC 驱动器](#)》（文献编号：SBOS688）
- 《[THS4551 低噪声、150MHz、精密全差分放大器](#)》（文献编号：SBOS778）
- 《[REF50xx 低噪声、极低漂移、高精度电压基准](#)》（文献编号：SBOS410）
- 《[OPAx378 低噪声、900kHz、RRIO、精密运算放大器零漂移系列](#)》（文献编号：SBOS417）

#### 11.2 接收文档更新通知

如需接收文档更新通知，请访问 [www.ti.com.cn](http://www.ti.com.cn) 网站上的器件产品文件夹。点击右上角的提醒我 (Alert me) 注册后，即可每周定期收到已更改的产品信息。有关更改的详细信息，请查阅已修订文档中包含的修订历史记录。

#### 11.3 社区资源

The following links connect to TI community resources. Linked contents are provided "AS IS" by the respective contributors. They do not constitute TI specifications and do not necessarily reflect TI's views; see TI's [Terms of Use](#).

**TI E2E™ Online Community** *TI's Engineer-to-Engineer (E2E) Community*. Created to foster collaboration among engineers. At [e2e.ti.com](http://e2e.ti.com), you can ask questions, share knowledge, explore ideas and help solve problems with fellow engineers.

**Design Support** *TI's Design Support* Quickly find helpful E2E forums along with design support tools and contact information for technical support.

#### 11.4 商标

multiSPI, TINA, E2E are trademarks of Texas Instruments.  
All other trademarks are the property of their respective owners.

#### 11.5 静电放电警告



ESD 可能会损坏该集成电路。德州仪器 (TI) 建议通过适当的预防措施处理所有集成电路。如果不遵守正确的处理措施和安装程序，可能会损坏集成电路。

ESD 的损坏小至导致微小的性能降级，大至整个器件故障。精密的集成电路可能更容易受到损坏，这是因为非常细微的参数更改都可能会导致器件与其发布的规格不相符。

#### 11.6 Glossary

[SLYZ022](#) — *TI Glossary*.

This glossary lists and explains terms, acronyms, and definitions.

## 12 机械、封装和可订购信息

以下页中包括机械、封装和可订购信息。这些信息是针对指定器件可提供的最新数据。这些数据会在无通知且不对本文档进行修订的情况下发生改变。欲获得该数据表的浏览器版本，请查阅左侧的导航栏。



## 重要声明

德州仪器(TI)及其下属子公司有权根据 JESD46 最新标准,对所提供的产品和服务进行更正、修改、增强、改进或其它更改,并有权根据 JESD48 最新标准中止提供任何产品和服务。客户在下订单前应获取最新的相关信息,并验证这些信息是否完整且是最新的。所有产品的销售都遵循在订单确认时所提供的TI 销售条款与条件。

TI 保证其所销售的组件的性能符合产品销售时 TI 半导体产品销售条件与条款的适用规范。仅在 TI 保证的范围内,且 TI 认为有必要时才会使用测试或其它质量控制技术。除非适用法律做出了硬性规定,否则没有必要对每种组件的所有参数进行测试。

TI 对应用帮助或客户产品设计不承担任何义务。客户应对其使用 TI 组件的产品和应用自行负责。为尽量减小与客户产品和应用相关的风险,客户应提供充分的设计与操作安全措施。

TI 不对任何 TI 专利权、版权、屏蔽作品权或其它与使用了 TI 组件或服务的组合设备、机器或流程相关的 TI 知识产权中授予的直接或隐含权限作出任何保证或解释。TI 所发布的与第三方产品或服务有关的信息,不能构成从 TI 获得使用这些产品或服务的许可、授权、或认可。使用此类信息可能需要获得第三方的专利权或其它知识产权方面的许可,或是 TI 的专利权或其它知识产权方面的许可。

对于 TI 的产品手册或数据表中 TI 信息的重要部分,仅在没有对内容进行任何篡改且带有相关授权、条件、限制和声明的情况下才允许进行复制。TI 对此类篡改过的文件不承担任何责任或义务。复制第三方的信息可能需要服从额外的限制条件。

在转售 TI 组件或服务时,如果对该组件或服务参数的陈述与 TI 标明的参数相比存在差异或虚假成分,则会失去相关 TI 组件或服务的所有明示或暗示授权,且这是不正当的、欺诈性商业行为。TI 对任何此类虚假陈述均不承担任何责任或义务。

客户认可并同意,尽管任何应用相关信息或支持仍可能由 TI 提供,但他们将独立负责满足与其产品及其在应用中使用的 TI 产品相关的所有法律、法规和安全相关要求。客户声明并同意,他们具备制定与实施安全措施所需的全部专业技术和知识,可预见故障的危险后果、监测故障及其后果、降低有可能造成人身伤害的故障的发生机率并采取适当的补救措施。客户将全额赔偿因在此类安全关键应用中使用任何 TI 组件而对 TI 及其代理造成的任何损失。

在某些场合中,为了推进安全相关应用有可能对 TI 组件进行特别的促销。TI 的目标是利用此类组件帮助客户设计和创立其特有的可满足适用的功能安全性标准和要求的终端产品解决方案。尽管如此,此类组件仍然服从这些条款。

TI 组件未获得用于 FDA Class III (或类似的生命攸关医疗设备)的授权许可,除非各方授权官员已经达成了专门管控此类使用的特别协议。

只有那些 TI 特别注明属于军用等级或“增强型塑料”的 TI 组件才是设计或专门用于军事/航空应用或环境的。购买者认可并同意,对并非指定面向军事或航空航天用途的 TI 组件进行军事或航空航天方面的应用,其风险由客户单独承担,并且由客户独立负责满足与此类使用相关的所有法律和法规要求。

TI 已明确指定符合 ISO/TS16949 要求的产品,这些产品主要用于汽车。在任何情况下,因使用非指定产品而无法达到 ISO/TS16949 要求, TI 不承担任何责任。

	产品		应用
数字音频	<a href="http://www.ti.com.cn/audio">www.ti.com.cn/audio</a>	通信与电信	<a href="http://www.ti.com.cn/telecom">www.ti.com.cn/telecom</a>
放大器和线性器件	<a href="http://www.ti.com.cn/amplifiers">www.ti.com.cn/amplifiers</a>	计算机及周边	<a href="http://www.ti.com.cn/computer">www.ti.com.cn/computer</a>
数据转换器	<a href="http://www.ti.com.cn/dataconverters">www.ti.com.cn/dataconverters</a>	消费电子	<a href="http://www.ti.com.cn/consumer-apps">www.ti.com.cn/consumer-apps</a>
DLP® 产品	<a href="http://www.dlp.com">www.dlp.com</a>	能源	<a href="http://www.ti.com.cn/energy">www.ti.com.cn/energy</a>
DSP - 数字信号处理器	<a href="http://www.ti.com.cn/dsp">www.ti.com.cn/dsp</a>	工业应用	<a href="http://www.ti.com.cn/industrial">www.ti.com.cn/industrial</a>
时钟和计时器	<a href="http://www.ti.com.cn/clockandtimers">www.ti.com.cn/clockandtimers</a>	医疗电子	<a href="http://www.ti.com.cn/medical">www.ti.com.cn/medical</a>
接口	<a href="http://www.ti.com.cn/interface">www.ti.com.cn/interface</a>	安防应用	<a href="http://www.ti.com.cn/security">www.ti.com.cn/security</a>
逻辑	<a href="http://www.ti.com.cn/logic">www.ti.com.cn/logic</a>	汽车电子	<a href="http://www.ti.com.cn/automotive">www.ti.com.cn/automotive</a>
电源管理	<a href="http://www.ti.com.cn/power">www.ti.com.cn/power</a>	视频和影像	<a href="http://www.ti.com.cn/video">www.ti.com.cn/video</a>
微控制器 (MCU)	<a href="http://www.ti.com.cn/microcontrollers">www.ti.com.cn/microcontrollers</a>		
RFID 系统	<a href="http://www.ti.com.cn/rfidsys">www.ti.com.cn/rfidsys</a>		
OMAP应用处理器	<a href="http://www.ti.com/omap">www.ti.com/omap</a>		
无线连通性	<a href="http://www.ti.com.cn/wirelessconnectivity">www.ti.com.cn/wirelessconnectivity</a>	德州仪器在线技术支持社区	<a href="http://www.deyisupport.com">www.deyisupport.com</a>

邮寄地址: 上海市浦东新区世纪大道1568号, 中建大厦32楼邮政编码: 200122  
Copyright © 2016, 德州仪器半导体技术(上海)有限公司

**PACKAGING INFORMATION**

Orderable Device	Status (1)	Package Type	Package Drawing	Pins	Package Qty	Eco Plan (2)	Lead/Ball Finish (6)	MSL Peak Temp (3)	Op Temp (°C)	Device Marking (4/5)	Samples
ADS9120IRGER	ACTIVE	VQFN	RGE	24	3000	Green (RoHS & no Sb/Br)	CU NIPDAU	Level-2-260C-1 YEAR	-40 to 125	ADS9120	<a href="#">Samples</a>
ADS9120IRGET	ACTIVE	VQFN	RGE	24	250	Green (RoHS & no Sb/Br)	CU NIPDAU	Level-2-260C-1 YEAR	-40 to 125	ADS9120	<a href="#">Samples</a>

(1) The marketing status values are defined as follows:

**ACTIVE:** Product device recommended for new designs.

**LIFEBUY:** TI has announced that the device will be discontinued, and a lifetime-buy period is in effect.

**NRND:** Not recommended for new designs. Device is in production to support existing customers, but TI does not recommend using this part in a new design.

**PREVIEW:** Device has been announced but is not in production. Samples may or may not be available.

**OBSELETE:** TI has discontinued the production of the device.

(2) Eco Plan - The planned eco-friendly classification: Pb-Free (RoHS), Pb-Free (RoHS Exempt), or Green (RoHS & no Sb/Br) - please check <http://www.ti.com/productcontent> for the latest availability information and additional product content details.

**TBD:** The Pb-Free/Green conversion plan has not been defined.

**Pb-Free (RoHS):** TI's terms "Lead-Free" or "Pb-Free" mean semiconductor products that are compatible with the current RoHS requirements for all 6 substances, including the requirement that lead not exceed 0.1% by weight in homogeneous materials. Where designed to be soldered at high temperatures, TI Pb-Free products are suitable for use in specified lead-free processes.

**Pb-Free (RoHS Exempt):** This component has a RoHS exemption for either 1) lead-based flip-chip solder bumps used between the die and package, or 2) lead-based die adhesive used between the die and leadframe. The component is otherwise considered Pb-Free (RoHS compatible) as defined above.

**Green (RoHS & no Sb/Br):** TI defines "Green" to mean Pb-Free (RoHS compatible), and free of Bromine (Br) and Antimony (Sb) based flame retardants (Br or Sb do not exceed 0.1% by weight in homogeneous material)

(3) MSL, Peak Temp. - The Moisture Sensitivity Level rating according to the JEDEC industry standard classifications, and peak solder temperature.

(4) There may be additional marking, which relates to the logo, the lot trace code information, or the environmental category on the device.

(5) Multiple Device Markings will be inside parentheses. Only one Device Marking contained in parentheses and separated by a "~" will appear on a device. If a line is indented then it is a continuation of the previous line and the two combined represent the entire Device Marking for that device.

(6) Lead/Ball Finish - Orderable Devices may have multiple material finish options. Finish options are separated by a vertical ruled line. Lead/Ball Finish values may wrap to two lines if the finish value exceeds the maximum column width.

**Important Information and Disclaimer:** The information provided on this page represents TI's knowledge and belief as of the date that it is provided. TI bases its knowledge and belief on information provided by third parties, and makes no representation or warranty as to the accuracy of such information. Efforts are underway to better integrate information from third parties. TI has taken and continues to take reasonable steps to provide representative and accurate information but may not have conducted destructive testing or chemical analysis on incoming materials and chemicals. TI and TI suppliers consider certain information to be proprietary, and thus CAS numbers and other limited information may not be available for release.

In no event shall TI's liability arising out of such information exceed the total purchase price of the TI part(s) at issue in this document sold by TI to Customer on an annual basis.

RGE (S-PVQFN-N24)

PLASTIC QUAD FLATPACK NO-LEAD

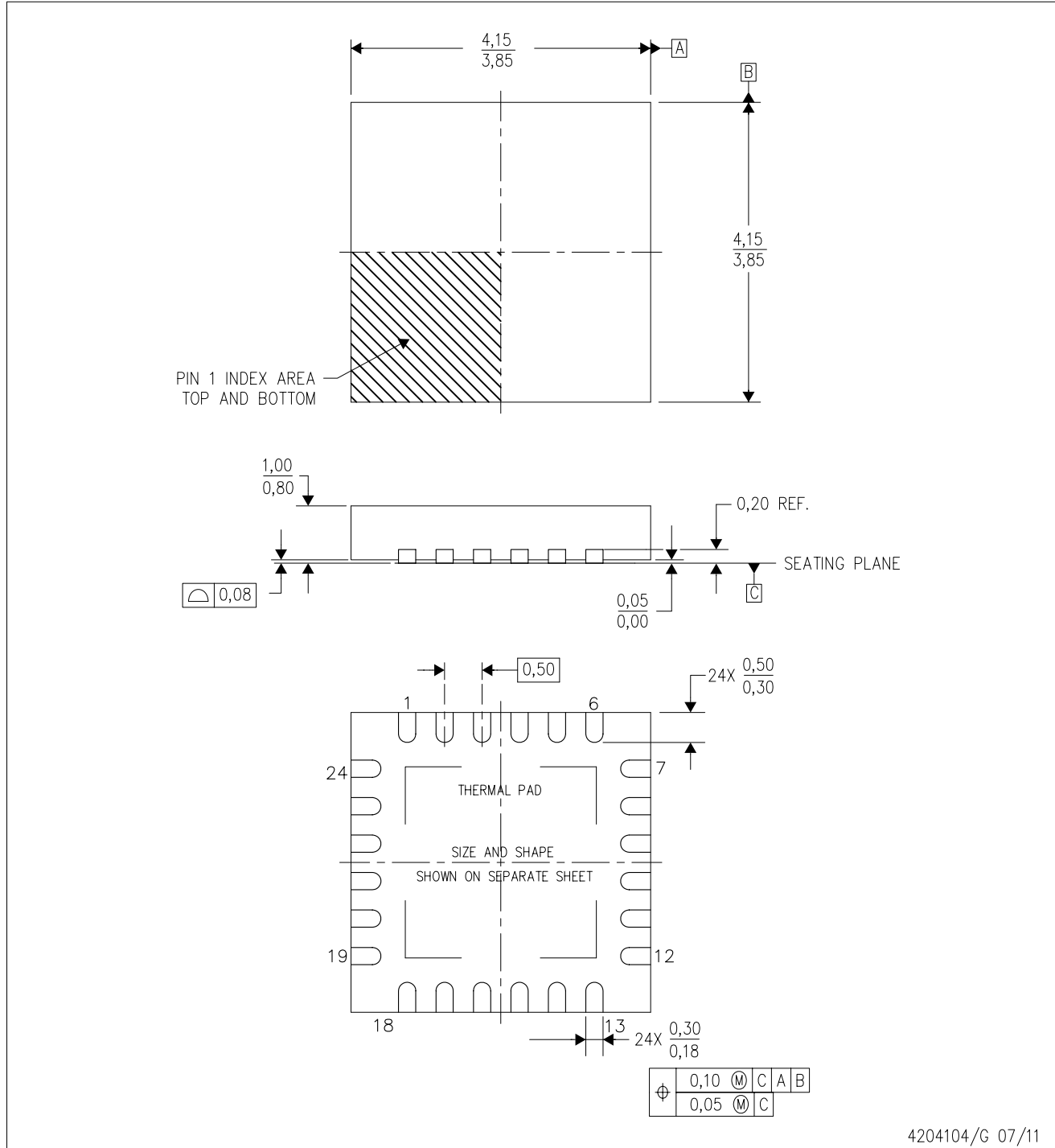

4204104/G 07/11

- NOTES:
- A. All linear dimensions are in millimeters. Dimensioning and tolerancing per ASME Y14.5M-1994.
  - B. This drawing is subject to change without notice.
  - C. Quad Flatpack, No-Leads (QFN) package configuration.
  - D. The package thermal pad must be soldered to the board for thermal and mechanical performance.
  - E. See the additional figure in the Product Data Sheet for details regarding the exposed thermal pad features and dimensions.
  - F. Falls within JEDEC MO-220.

## 重要声明

德州仪器(TI) 及其下属子公司有权根据 JESD46 最新标准, 对所提供的产品和服务进行更正、修改、增强、改进或其它更改, 并有权根据 JESD48 最新标准中止提供任何产品和服务。客户在下订单前应获取最新的相关信息, 并验证这些信息是否完整且是最新的。所有产品的销售都遵循在订单确认时所提供的TI 销售条款与条件。

TI 保证其所销售的组件的性能符合产品销售时 TI 半导体产品销售条件与条款的适用规范。仅在 TI 保证的范围内, 且 TI 认为有必要时才会使用测试或其它质量控制技术。除非适用法律做出了硬性规定, 否则没有必要对每种组件的所有参数进行测试。

TI 对应用帮助或客户产品设计不承担任何义务。客户应对其使用 TI 组件的产品和应用自行负责。为尽量减小与客户产品和应用相关的风险, 客户应提供充分的设计与操作安全措施。

TI 不对任何 TI 专利权、版权、屏蔽作品权或其它与使用了 TI 组件或服务的组合设备、机器或流程相关的 TI 知识产权中授予的直接或间接版权限作出任何保证或解释。TI 所发布的与第三方产品或服务有关的信息, 不能构成从 TI 获得使用这些产品或服务的许可、授权、或认可。使用此类信息可能需要获得第三方的专利权或其它知识产权方面的许可, 或是 TI 的专利权或其它知识产权方面的许可。

对于 TI 的产品手册或数据表中 TI 信息的重要部分, 仅在没有对内容进行任何篡改且带有相关授权、条件、限制和声明的情况下才允许进行复制。TI 对此类篡改过的文件不承担任何责任或义务。复制第三方的信息可能需要服从额外的限制条件。

在转售 TI 组件或服务时, 如果对该组件或服务参数的陈述与 TI 标明的参数相比存在差异或虚假成分, 则会失去相关 TI 组件或服务的所有明示或暗示授权, 且这是不正当的、欺诈性商业行为。TI 对任何此类虚假陈述均不承担任何责任或义务。

客户认可并同意, 尽管任何应用相关信息或支持仍可能由 TI 提供, 但他们将独立负责满足与其产品及其应用中使用 TI 产品相关的所有法律、法规和安全相关要求。客户声明并同意, 他们具备制定与实施安全措施所需的全部专业技术和知识, 可预见故障的危险后果、监测故障及其后果、降低有可能造成人身伤害的故障的发生机率并采取适当的补救措施。客户将全额赔偿因在此类安全关键应用中使用任何 TI 组件而对 TI 及其代理造成的任何损失。

在某些场合中, 为了推进安全相关应用有可能对 TI 组件进行特别的促销。TI 的目标是利用此类组件帮助客户设计和创立其特有的可满足适用的功能安全性标准和要求的终端产品解决方案。尽管如此, 此类组件仍然服从这些条款。

TI 组件未获得用于 FDA Class III (或类似的生命攸关医疗设备) 的授权许可, 除非各方授权官员已经达成了专门管控此类使用的特别协议。

只有那些 TI 特别注明属于军用等级或“增强型塑料”的 TI 组件才是设计或专门用于军事/航空应用或环境的。购买者认可并同意, 对并非指定面向军事或航空航天用途的 TI 组件进行军事或航空航天方面的应用, 其风险由客户单独承担, 并且由客户独立负责满足与此类使用相关的所有法律和法规要求。

TI 已明确指定符合 ISO/TS16949 要求的产品, 这些产品主要用于汽车。在任何情况下, 因使用非指定产品而无法达到 ISO/TS16949 要求, TI 不承担任何责任。

	产品		应用
数字音频	<a href="http://www.ti.com.cn/audio">www.ti.com.cn/audio</a>	通信与电信	<a href="http://www.ti.com.cn/telecom">www.ti.com.cn/telecom</a>
放大器和线性器件	<a href="http://www.ti.com.cn/amplifiers">www.ti.com.cn/amplifiers</a>	计算机及周边	<a href="http://www.ti.com.cn/computer">www.ti.com.cn/computer</a>
数据转换器	<a href="http://www.ti.com.cn/dataconverters">www.ti.com.cn/dataconverters</a>	消费电子	<a href="http://www.ti.com.cn/consumer-apps">www.ti.com.cn/consumer-apps</a>
DLP® 产品	<a href="http://www.dlp.com">www.dlp.com</a>	能源	<a href="http://www.ti.com.cn/energy">www.ti.com.cn/energy</a>
DSP - 数字信号处理器	<a href="http://www.ti.com.cn/dsp">www.ti.com.cn/dsp</a>	工业应用	<a href="http://www.ti.com.cn/industrial">www.ti.com.cn/industrial</a>
时钟和计时器	<a href="http://www.ti.com.cn/clockandtimers">www.ti.com.cn/clockandtimers</a>	医疗电子	<a href="http://www.ti.com.cn/medical">www.ti.com.cn/medical</a>
接口	<a href="http://www.ti.com.cn/interface">www.ti.com.cn/interface</a>	安防应用	<a href="http://www.ti.com.cn/security">www.ti.com.cn/security</a>
逻辑	<a href="http://www.ti.com.cn/logic">www.ti.com.cn/logic</a>	汽车电子	<a href="http://www.ti.com.cn/automotive">www.ti.com.cn/automotive</a>
电源管理	<a href="http://www.ti.com.cn/power">www.ti.com.cn/power</a>	视频和影像	<a href="http://www.ti.com.cn/video">www.ti.com.cn/video</a>
微控制器 (MCU)	<a href="http://www.ti.com.cn/microcontrollers">www.ti.com.cn/microcontrollers</a>		
RFID 系统	<a href="http://www.ti.com.cn/rfidsys">www.ti.com.cn/rfidsys</a>		
OMAP应用处理器	<a href="http://www.ti.com.cn/omap">www.ti.com.cn/omap</a>		
无线连通性	<a href="http://www.ti.com.cn/wirelessconnectivity">www.ti.com.cn/wirelessconnectivity</a>	德州仪器在线技术支持社区	<a href="http://www.deyisupport.com">www.deyisupport.com</a>

Mailing Address: Texas Instruments, Post Office Box 655303, Dallas, Texas 75265  
Copyright © 2016, Texas Instruments Incorporated