

# NB3V60113GV3

## 1.8 V 12.288 MHz OmniClock Generator with Single Ended (LVCMOS) Output

The NB3V60113GV3, which is a member of the OmniClock family, is a low power PLL-based clock generator. The device accepts a 6.144 MHz single ended (LVCMOS) reference clock as input. It generates one single ended (LVCMOS) output of 12.288 MHz. The device can be powered down using the Power Down pin (PD#).

### Features

- Member of the OmniClock Family of Programmable Clock Generators
- Operating Power Supply: 1.8 V  $\pm$  0.1 V
- I/O Standards
  - ◆ Input: 6.144 MHz Reference Clock (LVCMOS)
  - ◆ Output: 12.288 MHz (LVCMOS)
- Output Drive Current for Single Ended Output: 8 mA
- Power Saving Mode through Power Down Pin
- Temperature Range  $-40^{\circ}\text{C}$  to  $85^{\circ}\text{C}$
- Packaged in 8-Pin WDFN
- These are Pb-Free Devices

### Typical Application

- Audio Systems (Lightning Audio Module)



**ON Semiconductor®**

[www.onsemi.com](http://www.onsemi.com)



**WDFN8  
CASE 511AT**

### MARKING DIAGRAM

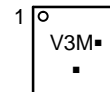

V3 = Specific Device Code  
M = Date Code  
■ = Pb-Free Device

(Note: Microdot may be in either location)

### ORDERING INFORMATION

See detailed ordering and shipping information on page 6 of this data sheet.

# NB3V60113GV3

## BLOCK DIAGRAM

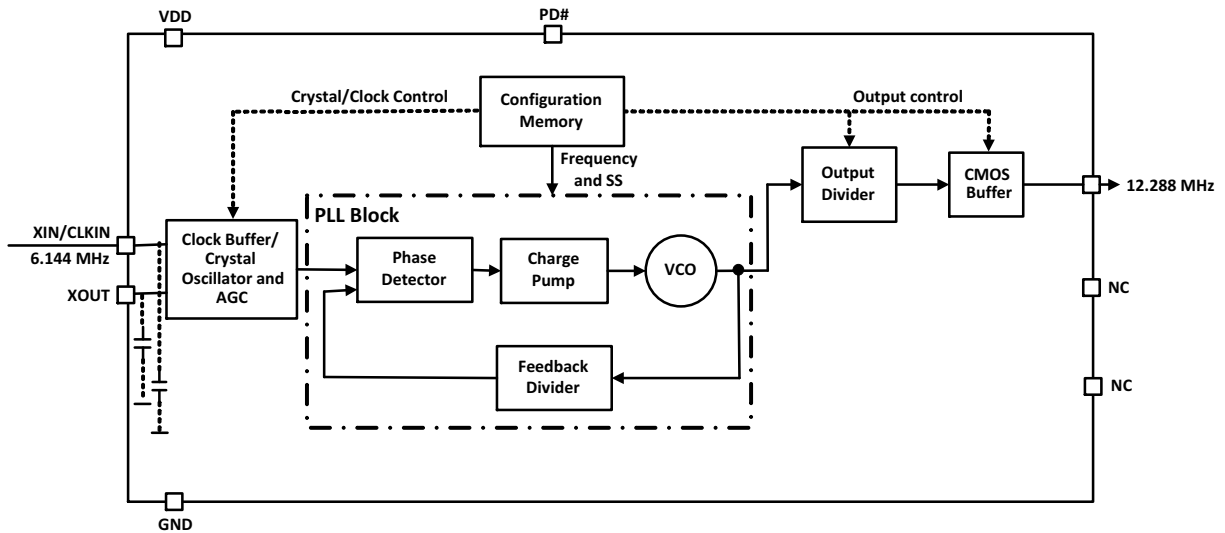

Figure 1. Simplified Block Diagram

## PIN FUNCTION DESCRIPTION

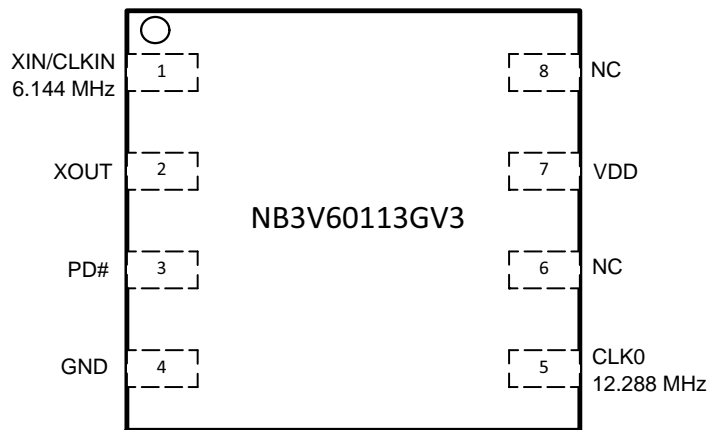

Figure 2. Pin Connections (Top View) – WDFN8

# NB3V60113GV3

**Table 1. PIN DESCRIPTION**

Pin No.	Pin Name	Pin Type	Description
1	XIN/CLKIN	Input	6.144 MHz single-ended external reference input clock (LVCMOS)
2	XOUT	Output	Crystal output. Float this pin when external reference clock is connected at XIN
3	PD#	Input	Asynchronous LVCMOS input. Active Low Master Reset to disable the device and set outputs Low. Internal pull-down resistor. This pin needs to be pulled High for normal operation of the chip.
4	GND	Ground	Power supply ground
5	CLK0	Output	12.288 MHz Single-ended (LVCMOS) output
6	NC	–	No Connection. Not to be connected to any circuit
7	VDD	Power	1.8 V Power Supply
8	NC	–	No Connection. Not to be connected to any circuit

**Table 2. POWER DOWN FUNCTION TABLE**

PD#	Function
0	Device Powered Down
1	Device Powered Up

NOTE: PD# has internal pull down resistor.

**Table 3. ATTRIBUTES**

Characteristic	Value
ESD Protection Human Body Model	2 kV
Internal Input Default State Pull up/ down Resistor	50 kΩ
Moisture Sensitivity, Indefinite Time Out of Dry Pack (Note 1)	MSL1
Flammability Rating Oxygen Index: 28 to 34	UL 94 V-0 @ 0.125 in
Transistor Count	130 k
Meets or exceeds JEDEC Spec EIA/JESD78 IC Latchup Test	

1. For additional information, see Application Note AND8003/D.

**Table 4. ABSOLUTE MAXIMUM RATING (Note 2)**

Symbol	Parameter	Rating	Unit
VDD	Positive power supply with respect to Ground	–0.5 to +4.6	V
V <sub>I</sub>	Input Voltage with respect to chip ground	–0.5 to VDD + 0.5	V
T <sub>A</sub>	Operating Ambient Temperature Range (Industrial Grade)	–40 to +85	°C
T <sub>STG</sub>	Storage temperature	–65 to +150	°C
T <sub>SOL</sub>	Max. Soldering Temperature (10 sec)	265	°C
θ <sub>JA</sub>	Thermal Resistance (Junction-to-ambient) (Note 3)	0 lfpm 500 lfpm	°C/W °C/W
θ <sub>JC</sub>	Thermal Resistance (Junction-to-case)	35 to 40	°C/W
T <sub>J</sub>	Junction temperature	125	°C

Stresses exceeding those listed in the Maximum Ratings table may damage the device. If any of these limits are exceeded, device functionality should not be assumed, damage may occur and reliability may be affected.

2. Maximum ratings applied to the device are individual stress limit values (not normal operating conditions) and not valid simultaneously. If stress limits are exceeded device functional operation is not implied, damage may occur and reliability may be affected.

3. JEDEC standard multilayer board – 2S2P (2 signal, 2 power). ESD51.7 type board. Back side Copper heat spreader area 100 sq mm, 2 oz (0.070 mm) copper thickness.

# NB3V60113GV3

**Table 5. RECOMMENDED OPERATION CONDITIONS**

Symbol	Parameter	Condition	Min	Typ	Max	Unit
V <sub>DD</sub>	Core Power Supply Voltage	1.8 V operation	1.7	1.8	1.9	V
CL	Clock output load capacitance for LVC MOS clock				15	pF
f <sub>clk</sub>	Reference Clock Frequency	Single ended Clock input (LVC MOS)		6.144		MHz
C <sub>X</sub>	XIN / XOUT pin stray Capacitance			4.5		pF

Functional operation above the stresses listed in the Recommended Operating Ranges is not implied. Extended exposure to stresses beyond the Recommended Operating Ranges limits may affect device reliability.

**Table 6. DC ELECTRICAL CHARACTERISTICS** (V<sub>DD</sub> = 1.8 V ± 0.1 V; GND = 0 V, T<sub>A</sub> = -40°C to +85°C)

Symbol	Parameter	Condition	Min	Typ	Max	Unit
I <sub>DD_1.8 V</sub>	Power Supply current	f <sub>out</sub> = 12.288 MHz		13		mA
I <sub>PD</sub>	Power Down Supply Current	PD# is Low to make all outputs OFF			20	μA
V <sub>IH</sub>	Input HIGH Voltage	Pin XIN/CLKIN	0.65 V <sub>DD</sub>		V <sub>DD</sub>	V
		Pin PD#	0.85 V <sub>DD</sub>		V <sub>DD</sub>	
V <sub>IL</sub>	Input LOW Voltage	Pin XIN/CLKIN	0		0.35 V <sub>DD</sub>	V
		Pin PD#	0		0.15 V <sub>DD</sub>	
C <sub>in</sub>	Input Capacitance	Pin PD#		4	6	pF

**LVC MOS OUTPUT**

V <sub>OH</sub>	Output HIGH Voltage	V <sub>DD</sub> = 1.8 V	I <sub>OH</sub> = 8 mA	0.75*V <sub>DD</sub>		V
V <sub>OL</sub>	Output LOW Voltage	V <sub>DD</sub> = 1.8 V	I <sub>OL</sub> = 8 mA		0.25*V <sub>DD</sub>	V

Product parametric performance is indicated in the Electrical Characteristics for the listed test conditions, unless otherwise noted. Product performance may not be indicated by the Electrical Characteristics if operated under different conditions.

**Table 7. AC ELECTRICAL CHARACTERISTICS** (V<sub>DD</sub> = 1.8 V ± 0.1 V, GND = 0 V, T<sub>A</sub> = -40°C to +85°C)

Symbol	Parameter	Conditions	Min	Typ	Max	Unit
f <sub>out</sub>	Single Ended Output Frequency			12.288		MHz
t <sub>PU</sub>	Stabilization time from Power-up	V <sub>DD</sub> = 1.8 V		3.0		ms
t <sub>PD</sub>	Stabilization time from Power Down	Time from falling edge on PD# pin to tri-stated outputs (Asynchronous)		3.0		ms
E <sub>ppm</sub>	Synthesis Error			0		ppm

**SINGLE ENDED OUTPUT** (V<sub>DD</sub> = 1.8 V ± 0.1 V; T<sub>A</sub> = -40°C to 85°C)

t <sub>JITTER-1.8 V</sub>	Period Jitter Peak-to-Peak	Configuration Dependent		200		ps
	Cycle-Cycle Peak Jitter	Configuration Dependent		200		
t <sub>r</sub> / t <sub>f</sub> 1.8 V	Rise/Fall Time	Measured between 20% to 80% with 15 pF load, f <sub>out</sub> = 12.288 MHz, V <sub>DD</sub> = 1.8 V		1		ns
t <sub>DC</sub>	Output Clock Duty Cycle	V <sub>DD</sub> = 1.8 V; Duty Cycle of Ref clock is 50% PLL Clock	45	50	55	%

PARAMETER MEASUREMENT TEST CIRCUIT

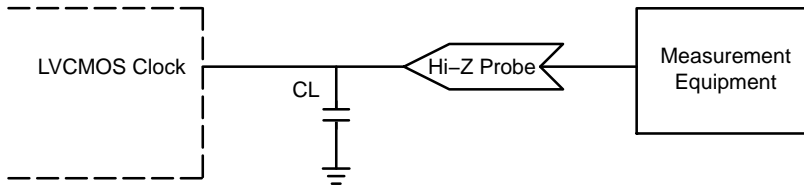

Figure 3. LVC MOS Clock Parameter Measurement

TIMING MEASUREMENT DEFINITIONS

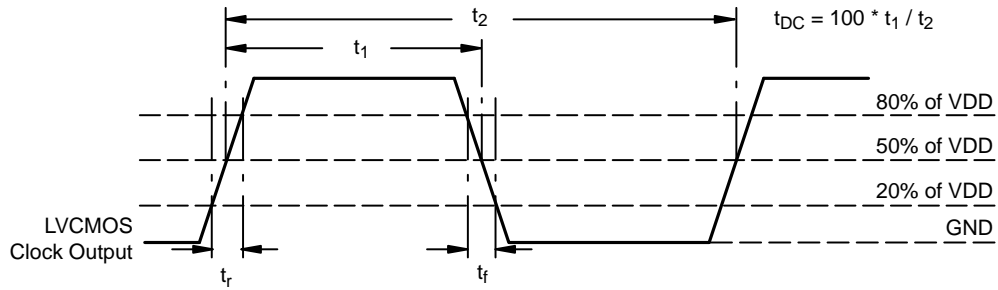

Figure 4. LVC MOS Measurement for AC Parameters

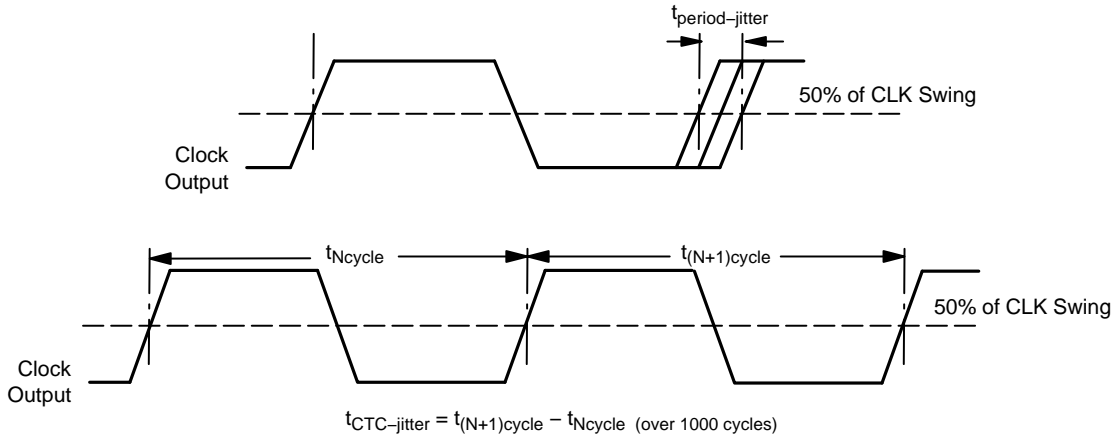
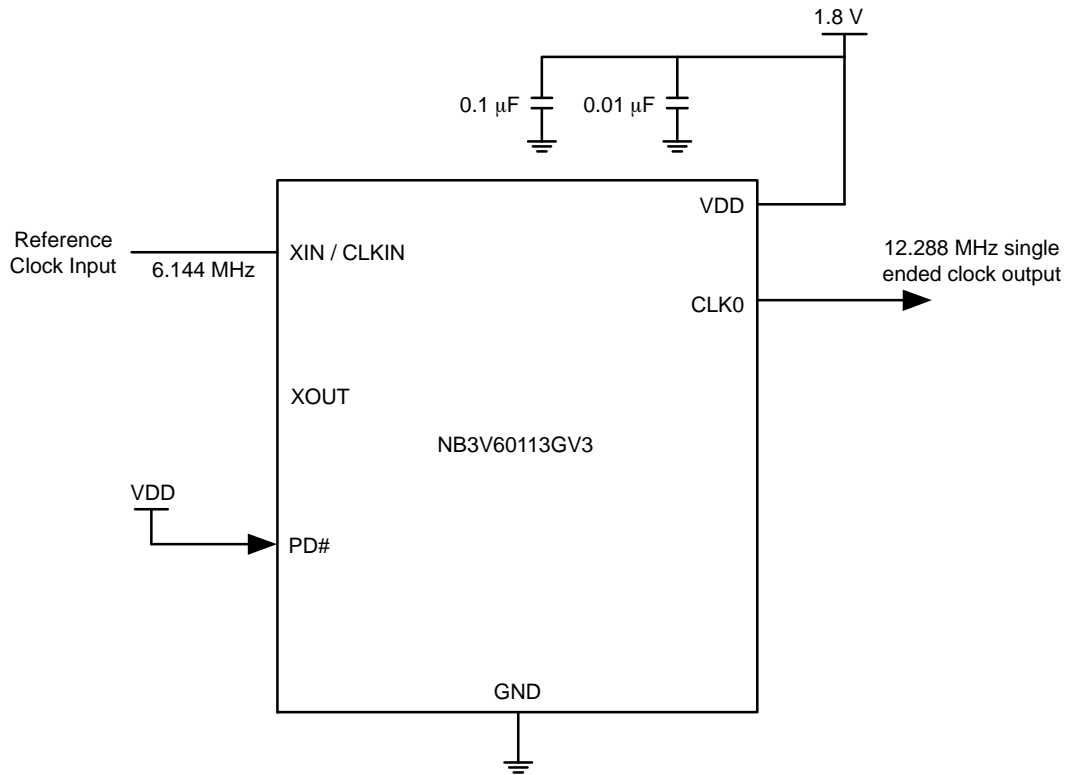

Figure 5. Period and Cycle-to-Cycle Jitter Measurement

# NB3V60113GV3



**Figure 6. Typical Application Setup**

## ORDERING INFORMATION

Device	Case	Package	Shipping <sup>†</sup>
NB3V60113GV3MTR2G	511AT	DFN-8 (Pb-Free)	3000 / Tape & Reel

<sup>†</sup>For information on tape and reel specifications, including part orientation and tape sizes, please refer to our Tape and Reel Packaging Specifications Brochure, BRD8011/D.

NOTE: Please contact your ON Semiconductor sales representative for information on un-programmed versions of this device.

# NB3V60113GV3

## PACKAGE DIMENSIONS

WDFN8 2x2, 0.5P  
CASE 511AT  
ISSUE O

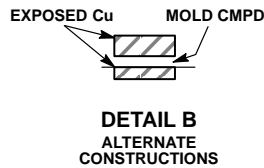
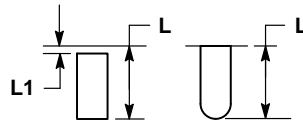
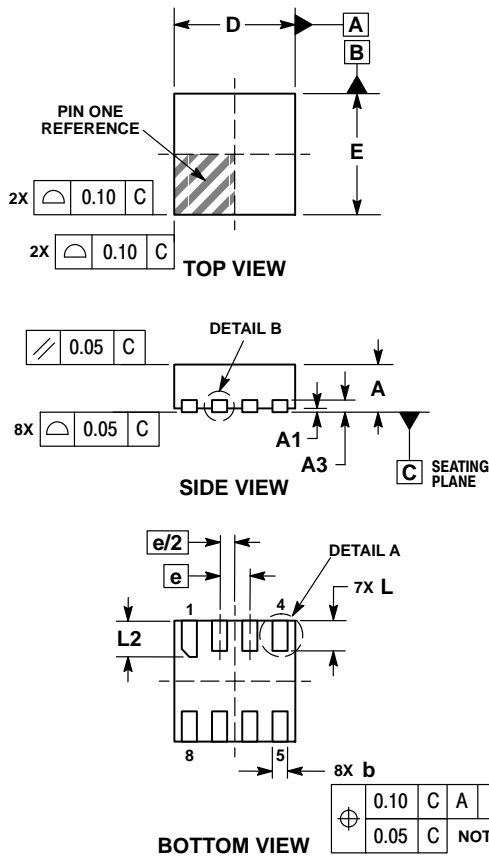

**NOTES:**

1. DIMENSIONING AND TOLERANCING PER ASME Y14.5M, 1994.
2. CONTROLLING DIMENSION: MILLIMETERS.
3. DIMENSION b APPLIES TO PLATED TERMINAL AND IS MEASURED BETWEEN 0.15 AND 0.30 MM FROM TERMINAL TIP.

DIM	MILLIMETERS	
	MIN	MAX
A	0.70	0.80
A1	0.00	0.05
A3	0.20 REF	
b	0.20	0.30
D	2.00 BSC	
E	2.00 BSC	
e	0.50 BSC	
L	0.40	0.60
L1	---	0.15
L2	0.50	0.70

**RECOMMENDED SOLDERING FOOTPRINT\***

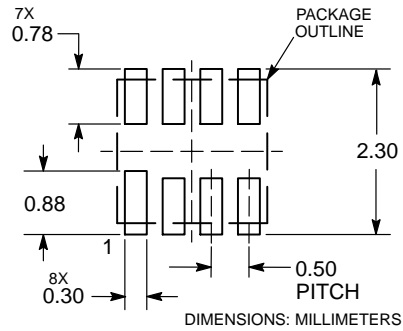

\*For additional information on our Pb-Free strategy and soldering details, please download the ON Semiconductor Soldering and Mounting Techniques Reference Manual, SOLDERRM/D.

ON Semiconductor and are trademarks of Semiconductor Components Industries, LLC dba ON Semiconductor or its subsidiaries in the United States and/or other countries. ON Semiconductor owns the rights to a number of patents, trademarks, copyrights, trade secrets, and other intellectual property. A listing of ON Semiconductor's product/patent coverage may be accessed at [www.onsemi.com/site/pdf/Patent-Marking.pdf](http://www.onsemi.com/site/pdf/Patent-Marking.pdf). ON Semiconductor reserves the right to make changes without further notice to any products herein. ON Semiconductor makes no warranty, representation or guarantee regarding the suitability of its products for any particular purpose, nor does ON Semiconductor assume any liability arising out of the application or use of any product or circuit, and specifically disclaims any and all liability, including without limitation special, consequential or incidental damages. Buyer is responsible for its products and applications using ON Semiconductor products, including compliance with all laws, regulations and safety requirements or standards, regardless of any support or applications information provided by ON Semiconductor. "Typical" parameters which may be provided in ON Semiconductor data sheets and/or specifications can and do vary in different applications and actual performance may vary over time. All operating parameters, including "Typicals" must be validated for each customer application by customer's technical experts. ON Semiconductor does not convey any license under its patent rights nor the rights of others. ON Semiconductor products are not designed, intended, or authorized for use as a critical component in life support systems or any FDA Class 3 medical devices or medical devices with a same or similar classification in a foreign jurisdiction or any devices intended for implantation in the human body. Should Buyer purchase or use ON Semiconductor products for any such unintended or unauthorized application, Buyer shall indemnify and hold ON Semiconductor and its officers, employees, subsidiaries, affiliates, and distributors harmless against all claims, costs, damages, and expenses, and reasonable attorney fees arising out of, directly or indirectly, any claim of personal injury or death associated with such unintended or unauthorized use, even if such claim alleges that ON Semiconductor was negligent regarding the design or manufacture of the part. ON Semiconductor is an Equal Opportunity/Affirmative Action Employer. This literature is subject to all applicable copyright laws and is not for resale in any manner.

**PUBLICATION ORDERING INFORMATION**

**LITERATURE FULFILLMENT:**  
Literature Distribution Center for ON Semiconductor  
19521 E. 32nd Pkwy, Aurora, Colorado 80011 USA  
**Phone:** 303-675-2175 or 800-344-3860 Toll Free USA/Canada  
**Fax:** 303-675-2176 or 800-344-3867 Toll Free USA/Canada  
**Email:** [orderlit@onsemi.com](mailto:orderlit@onsemi.com)

**N. American Technical Support:** 800-282-9855 Toll Free  
USA/Canada  
**Europe, Middle East and Africa Technical Support:**  
Phone: 421 33 790 2910  
**Japan Customer Focus Center**  
Phone: 81-3-5817-1050

**ON Semiconductor Website:** [www.onsemi.com](http://www.onsemi.com)  
**Order Literature:** <http://www.onsemi.com/orderlit>  
For additional information, please contact your local Sales Representative