

# BRUSHLESS MOTORS WITH INTEGRAL CONTROL



- › Industry
- › Medical
- › Railway
- › Renewable energy

# ABOUT CROUZET MOTORS

All around the world for more than 50 years, Crouzet Motors has been providing engineering expertise, high quality support and a complete offer of standard and customized direct drive and geared motors for all applications where performance is the key issue

Crouzet Motors is a brand of InnoVista Sensors™.

With a long-term commitment to technological excellence, the engineering teams have mastered the following core technologies and know-how:

- › Electromagnetism
- › Thermal dynamics
- › Electromechanical systems
- › Electronic drives

Covering the power range 1 to 400 watts (1/100 to 1/2 hp+) and available with spur, worm and planetary gearboxes plus adapted controllers, the Crouzet Motors' product offering is specifically designed for Medical Equipment, Railways, Aeronautics, Industry, Pumps and Valves.

## INNOVISTA SENSORS

InnoVista Sensors™: your trusted partner of choice to face industrial challenges of today and tomorrow.

InnoVista Sensors™ is a worldwide industrial specialist of sensors, controllers and actuators for automated systems.

Through its brands, Crouzet Aerospace, Crouzet Automation, Crouzet Control, Crouzet Motors, Crouzet Switches and Systron Donner Inertial, InnoVista Sensors™ offers a wide range of reliable, efficient and customizable components dedicated to the Aerospace & Defense, Transportation and Industrial market and segments.

Thanks to the recognized expertise of its teams and a strong innovation policy, InnoVista Sensors™ brings performance enhancing solutions to its customers worldwide.

[www.innovistasensors.com](http://www.innovistasensors.com)

### Designs & Manufactures



Sensors



Controls



Actuators

### For



Aerospace  
& Defense



Transportation



Industry

### With commercial brands



# ADAPTATION WHEEL

To meet market expectations and provide customers with the right solutions within the shortest timeframes, Crouzet Motors has structured its processes around the different types of product available: standard products, adapted products or products specially developed for a customer. Introducing the adaptation wheel...

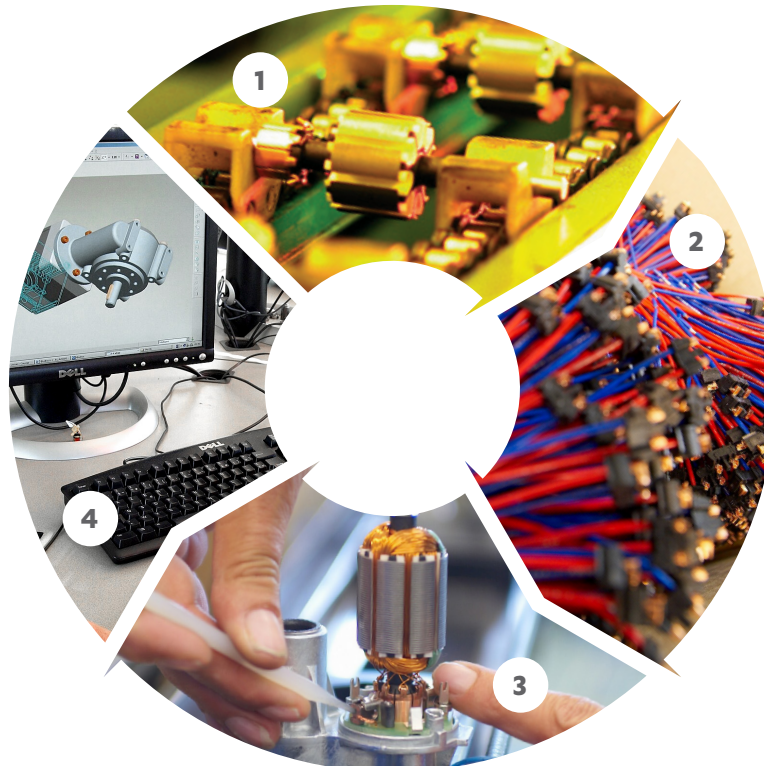

## 1 STANDARD PRODUCTS

### Sales service

A full range of motors, geared motors and associated controllers. You can create your automation control applications as quickly as possible

## 2 PRODUCTS WITH ADDED VALUE

### Customer Adaptation Centre

All our standard products can have additional factory-mounted auxiliaries or accessories: connectors, leads, special terminals, customized shafts, adaptor plates, etc. Seamless integration in your equipment means you benefit from simpler logistics and optimum installation reliability.

## 3 ADAPTED PRODUCTS

### Customer Adaptation Centre

Defined in coordination between your project teams and our specialists, these adapted products have exactly the right levels of performance and functionality you need for your applications.

## 4 SPECIAL PRODUCTS

### Engineers and teams Dedicated project

From the very start of a project, Crouzet Motors' experts work closely with your teams to develop the specification. All our design, industrialization and approval expertise goes into developing Motion Control solutions that are tailored to your requirements.

# DCmind BRUSHLESS

**Crouzet Motors, a specialist in customized motorization solutions, now launches the new generation of High Performance Brushless motors with integrated electronics TNi21 and SMi21.**

A pioneer on the European market in 2002 with the Motomate, a Brushless motor with integrated electronics incorporating an intuitive visual programming interface, Crouzet Motors is blazing a new trail for compact standalone applications.

Crouzet Motors, a company continually evolving to meet customer needs, has upgraded its ranges with accessories, gearboxes, new part numbers and now, thanks to these new electronic devices, has enhanced the performance of its products with:

- › more power
- › more accuracy
- › more functions
- › simplicity of use and ease of integration.

## TWO NEW ELECTRONIC PILOT CONTROL DEVICES

- › The TNi21 for simpler applications, dedicated to speed and torque control.
- › The SMi21, dedicated to motion control for applications that require accuracy. Thanks to a 4096-point encoder, it offers all the following control functions: position, torque, speed, direction, braking, etc.

### BRAKING AND HOLDING

With or without failsafe holding brake (active braking is performed by the motor electronics).

### CONTROL

- › TNi21: 4 inputs and 3 outputs, torque and speed control on analog inputs with 10-bit resolution.
- › SMi21: 6 inputs and 4 outputs, the motor has a wide selection of programs which can be set via a PC (position, speed and torque) and can reach as many as 65,000 positions.

### COMMUNICATING

A micro-USB socket on the motor (SMi21) can be used to link this directly to a PC.

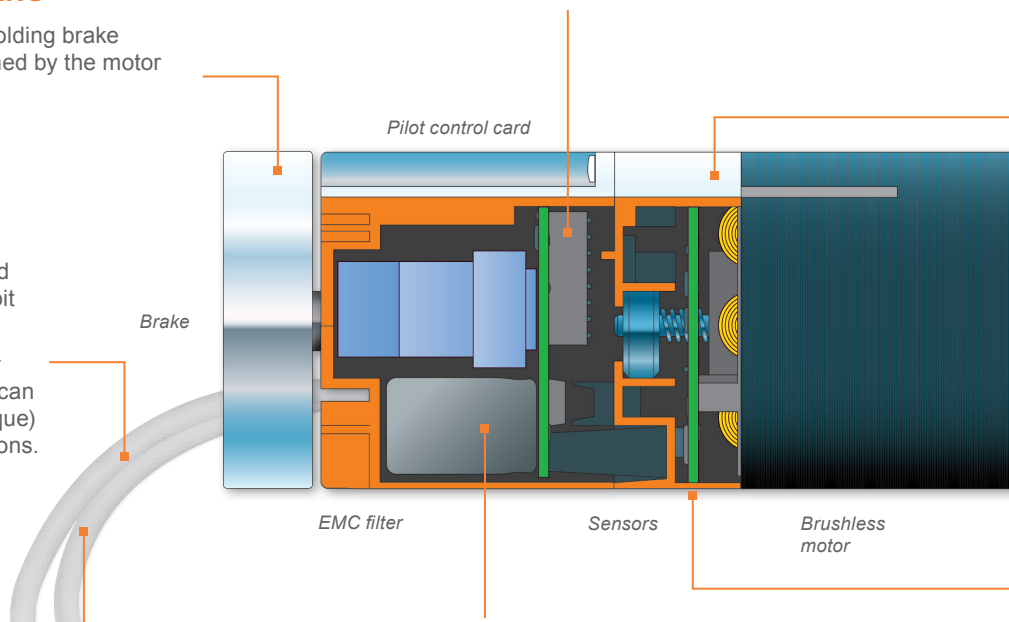

### POWER SUPPLY

Single supply voltage needed across the whole voltage range:

- › TNi21 (10 - 36 VDC)
- › SMi21 (9 - 56 VDC)

### FILTERING AND PROTECTING

- › Short-circuits, undervoltages
- › EMC (received and transmitted)
- › Temperature
- › Mechanical (vibrations, shocks, etc.)

## THE MOTOR'S INTEGRATED ELECTRONICS ALLOW YOU TO:

### PRODUCT ADVANTAGES

- › **Easy and accurate** control thanks to an optimized control loop
- › Improved **safety** with internal thermal protection
- › **Safe, reliable operation** as a result of its excellent EMC characteristics, due to the shortest possible wiring and shielding with a metal cover

### USER ADVANTAGES

- › **Save time and improve reliability** due to less wiring and fewer connections.
- › **Control the logistic problem** better with fewer part numbers to manage
- › **Save space** thanks to a more compact solution

### PILOT CONTROL

Motor pilot control card for operation in 4 quadrants, sine operation (SMi21) or trapezoidal operation (TNi21).

### GEARBOXES

Using Crouzet Motors gearboxes, the motor speed and torque can be adapted to your applications from 0.01 to 4000 rpm and 0.1 to 120 Nm (0.9 to 1062 in-lbs).

Gearbox

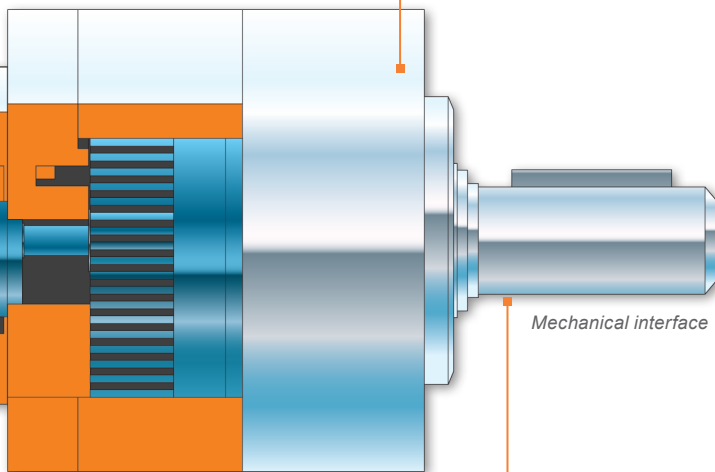

Mechanical interface

### SENSING

3 Hall effects for identifying the rotor position.  
SMi21: plus 1 encoder (4096 pulses per motor revolution) for precision of regulation and sinusoidal power supply to the coils.

### INTEGRATION

Crouzet Motors adapts the mechanical interfaces of its solutions for perfect integration in your equipment: fixing plate, transmission shafts, special pinions.

# INTEGRATED ELECTRONICS

## TNi21 SPEED AND TORQUE CONTROL:

- › 4 inputs, 3 outputs.
- › 2 x 10-bit analog inputs for fine-tuned speed and torque control.
- › 4 rejective quadrants.
- › Use on its own or in combination with other motors or controlled by a PLC.
- › Can be used in production immediately (without setup stage).
- › Also suitable for a 12 V or 24 V battery power supply (voltage range between 10 and 36 volts).

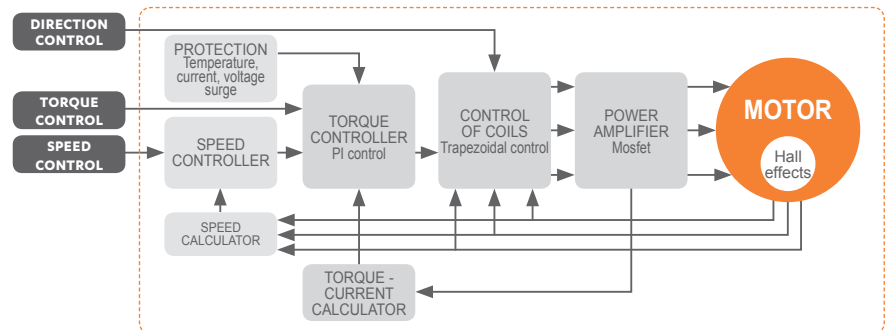





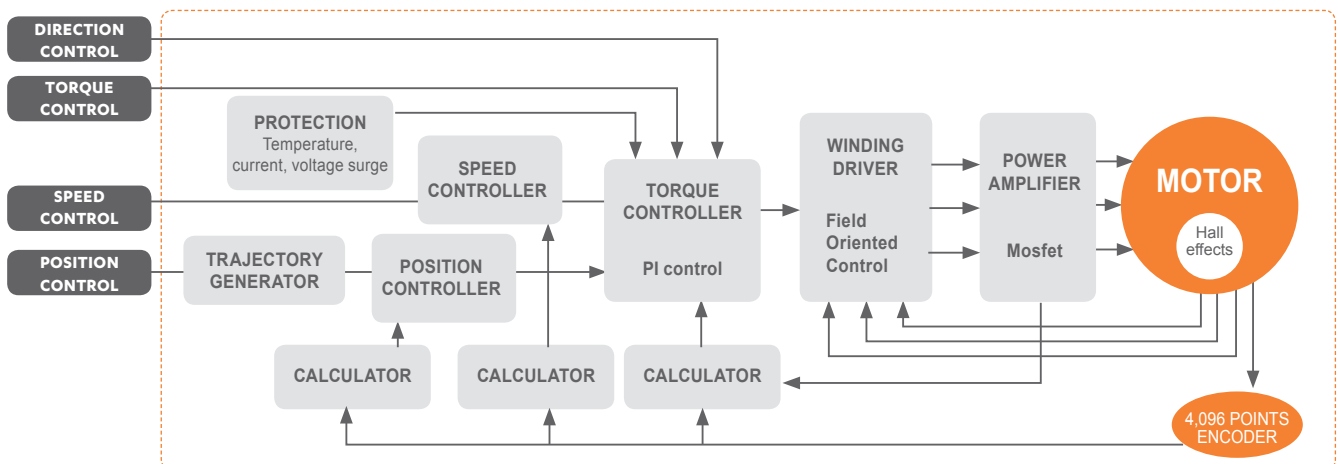













## SMi21 POSITION, SPEED AND TORQUE CONTROL:

- › 6 inputs and 4 outputs, 2 of which are 10-bit analog inputs.
- › Intuitive, easy-to-use setup software - with application mode for quick start-up.
- › Very flexible thanks to the various programs on offer. All the parameters are adjustable and can be used to optimise application operation.
- › Also suitable for a 12 V, 24 V or 48 V battery power supply (voltage range between 9 and 56 volts).
- › Low power consumption when idling (1 W).
- › Rotor position controlled with 4096-point encoder and use of sinusoidal vector control.
- › Reprogramming and re-use of motors as required by changing the application program or by modifying the configuration.
- › Firmware updating made easier with the “bootloader” function.
- › Use on its own, in combination with other motors or controlled by a PLC.



# THE NEW RANGE

MOTOR TYPE		Nominal usable power at 24 VDC	Max. usable power	TYPE OF GEARBOX			
				P52 25 Nm max.	P62 50 Nm max.	P81 120 Nm max.	RAD10 10 Nm max.
80140 	TNi21	77 W	150 W	801495 TNi21 	801496 TNi21 	-	801410 TNi21 
	SMi21	92 W	184 W	801495 SMi21 	801496 SMi21 	-	801410 SMi21 
80180 	TNi21	100 W	211 W	-	801896 TNi21 	801897 TNi21 	801810 TNi21 
	SMi21	105 W	314 W	-	801896 SMi21 	801897 SMi21 	801810 SMi21 
80280 	TNi21	133 W	251 W	-	-	802897 TNi21 	802810 TNi21 
	SMi21	170 W	419 W	-	-	802897 SMi21 	802810 SMi21 

Nominal power ratings may vary according to the supply voltage.  
 Maximum power ratings are given for the maximum permissible motor voltage.  
 Example: the 80 280 SMi21 motor develops peak mechanical power of 419 W at 48 VDC.

## OPTIONS AND ACCESSORIES

### TNi21

- › Motors available with or without mechanical brake for holding at breaking current.
- › Supplied with 1 control cable and a power supply cable or with a M16 12-pin connector output including all the connections (motors 80140 and 80180).
- › Accessory, shielded cable and 12-pin M16 connector.

### SMi21

- › Motors available with or without mechanical brake for holding at breaking current.
- › Requires a standard commercially-available USB/ micro-USB cable and the setup software. This can be downloaded free of charge from the Crouzet website or ordered in the form of a "starter kit".



# SMi21: DCmind-SOFT SIMPLIFIED PROGRAMMING

[www.crouzet.com](http://www.crouzet.com)

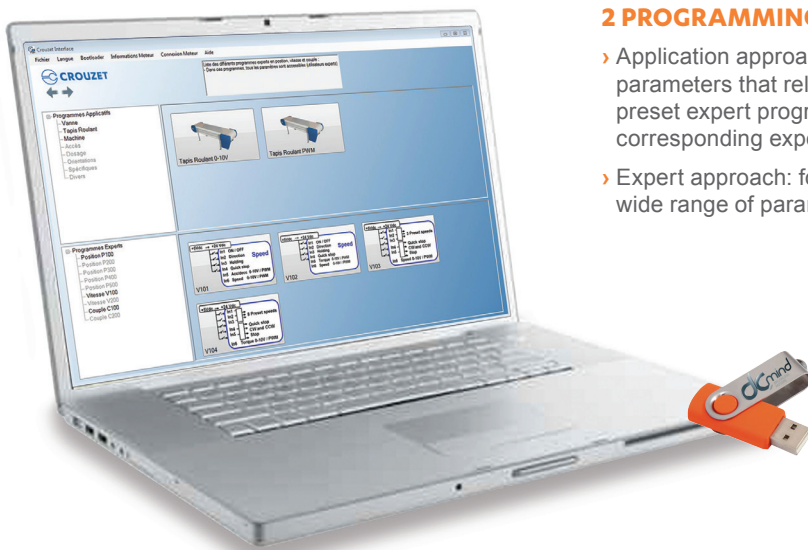

## SIMPLE AND INTUITIVE SOFTWARE

Available in several languages, with multiple possible uses, at any level of performance.

## 2 PROGRAMMING MODES

- › Application approach: Select an application template, then set only those parameters that relate directly to your application. These programs use preset expert programs. You can fine-tune these settings by calling up the corresponding expert program.
- › Expert approach: for automation system programs and settings covering a wide range of parameters.

## DCmind-SOFT

Available on our website [www.crouzet.com](http://www.crouzet.com), or can be supplied on a USB stick in the "starter kit".

## APPLICATIONS

Varied applications where position control, repeated movement and accuracy are key factors.



Stepper operation, detection of thrust and proportional adjustment of forces.



Performing cyclical operation, adjustment of speed and forces. Set to safety mode in the event of a fault.

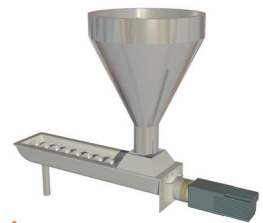

Several motors combined, operation without a PLC, ease of assembly.



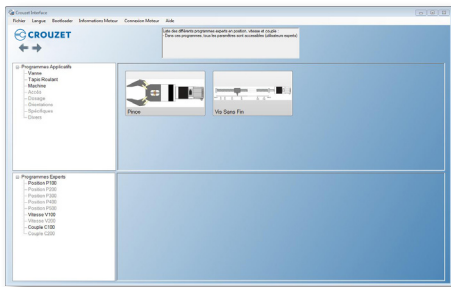

“Application” menu

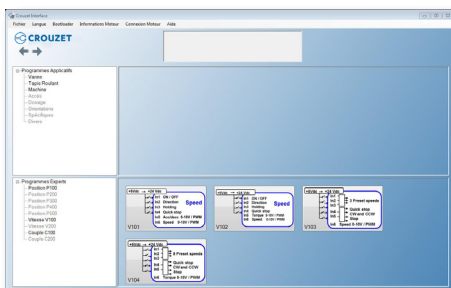

“Expert” menu



“Parameter definition” mode

**CHARACTERISTICS**

**3 languages:**

English, French, German.

**Operating system:**

XP Family, XP Pro, Vista, Windows 7.

**Application programs:**

Valve, conveyor belt, clamp, format adjustment, etc.

**Expert programs:**

Position, speed, torque with digital and analog inputs.

› Numerous programs are available, offering:

- 65,000 proportional positions which can be selected by two 0/10V inputs
- 30 independent positions which can be selected by digital encoding
- A variety of outputs which can be selected to suit your requirements
- The option of setting inverted inputs, selecting 0/10V or PWM operation on the analog inputs, and even setting their operating limit stops
- The option of modifying the control loop PID parameters for difficult applications
- Automatic detection of the reference position for position control (“homing” function)

› Special programs created on request, firmware updating made easier with the “Bootloader” function

› Loading programs simplified with a USB connection

› Other programs to come, please visit our website

**SOME EXAMPLES OF APPLICATIONS**

Format adjustment, automatic feed, synchronization, flow control, accurate dosage.

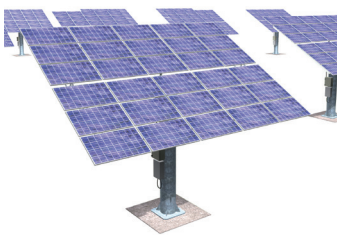

Operation on 12 V battery, low consumption.

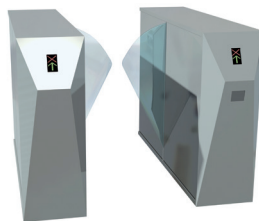

S curve pilot control and operation on 12 V backup battery.

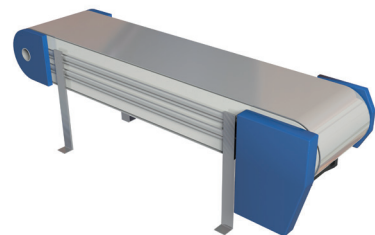

Speed pilot control

# DCmind: BRUSHLESS MOTORS

## Motors 38 to 145 W nominal output power range with TNi21 Speed and Torque Control

- > For control speed and torque applications
- > Very high power density
- > 4 inputs (where 2 of them analog) / 3 outputs integrated electronic controls
- > Holding torque function
- > Battery supply compatible 12 V and 24 V



### Part numbers

	38 to 75 W	45 to 102 W	72 to 145 W
Type	80140 TNi21	80180 TNi21	80280 TNi21
<b>Part numbers</b>			
PWM speed mode, cable output	<b>80140059</b>	<b>80180056</b>	<b>80280013</b>
0-10 V speed mode, cable output	<b>80140051</b>	<b>80180050</b>	<b>80280007</b>
PWM speed mode, connector M16 - 12 pins	<b>80140079</b>	<b>80180072</b>	
0-10 V speed mode, connector M16 - 12 pins	<b>80140071</b>	<b>80180066</b>	
Nominal power supply range (V <sub>DC</sub> )	12 - 32	12 - 32	12 - 32
Min. max. power supply (V <sub>DC</sub> )	10 - 36	10 - 36	10 - 36
<b>No-load characteristics</b>			
Speed of rotation (rpm)	12 V <sub>DC</sub> 24 V <sub>DC</sub> 32 V <sub>DC</sub> 2900 4000 4000	12 V <sub>DC</sub> 24 V <sub>DC</sub> 32 V <sub>DC</sub> 2100 4000 3950	12 V <sub>DC</sub> 24 V <sub>DC</sub> 32 V <sub>DC</sub> 2000 3950 3950
Absorbed current (A)	0.34 0.29 0.27	0.35 0.39 0.34	0.5 0.7 0.6
<b>Nominal characteristics</b>			
Speed (rpm)	12 V <sub>DC</sub> 24 V <sub>DC</sub> 32 V <sub>DC</sub> 1900 4000 4000	12 V <sub>DC</sub> 24 V <sub>DC</sub> 32 V <sub>DC</sub> 1250 3350 3900	12 V <sub>DC</sub> 24 V <sub>DC</sub> 32 V <sub>DC</sub> 1400 3250 3900
Absorbed current (A)	5.2 4.4 3.2	6.7 5.4 4	8.5 6.9 6
Torque (mNm)	193 184 178	340 285 250	490 390 355
Output power (W)	38 77 75	45 100 102	72 133 145
<b>Maximal characteristics</b>			
Speed (rpm)	12 V <sub>DC</sub> 24 V <sub>DC</sub> 32 V <sub>DC</sub> 1600 3050 4000	12 V <sub>DC</sub> 24 V <sub>DC</sub> 32 V <sub>DC</sub> 1040 2160 3100	12 V <sub>DC</sub> 24 V <sub>DC</sub> 32 V <sub>DC</sub> 800 1900 2400
Absorbed current (A)	6.5 10 10	7.2 11 12	15 15 12.5
Torque (mNm)	250 358 358	400 600 650	1000 1000 1000
Output power (W)	42 114 150	44 136 211	84 199 251
<b>General characteristics</b>			
Regulation (quadrants)	4	4	4
Conformity to EMC Directive in accordance with (EN 55022)	Class B	Class B	Class B
Insulation conforming to IEC60085	Class E	Class E	Class B
Thermal time constant (mn)	20	30	30
Noise level (dBA)	40	40	50
Inertia (g.cm <sup>2</sup> )	75	115	120
Number of rotor poles	4	4	8
Ambient operating temperature (°C)	-30 → +70	-30 → +70	-30 → +70
Service life (h)	20000	20000	20000
Ball bearing	✓	✓	✓
Weight (kg)	0.95	1.34	1.44
<b>0-10 V or PWM Speed input characteristics</b>			
Input impedance (kΩ)	69	69	69
Speed control (rpm)	120 → 4000	120 → 4000	120 → 4000
Level 0 input voltage (V)	0 → 2	0 → 2	0 → 2
Level 1 input voltage (V)	7.5 → 39	7.5 → 39	7.5 → 39
Frequency range (Hz)	100 → 2000	100 → 2000	100 → 2000
<b>0-10 V or PWM Torque input characteristics</b>			
Input impedance (kΩ)	69	69	69
Torque limit (mNm)	360 → 35	700 → 30	1000 → 40
Holding limit (mNm)	150 → 35	230 → 30	310 → 40
Level 0 input voltage (V)	0 → 2	0 → 2	0 → 2
Level 1 input voltage (V)	7.5 → 39	7.5 → 39	7.5 → 39
Frequency range (Hz)	100 → 2000	100 → 2000	100 → 2000
<b>On/Off and Direction digital input characteristics</b>			
Input impedance (kΩ)	57	57	57
Level 0 input voltage (V <sub>DC</sub> )	0 → 2	0 → 2	0 → 2
Level 1 input voltage (V <sub>DC</sub> )	4 → 39	4 → 39	4 → 39
<b>Torque alarm, Encoder and Direction output characteristics</b>			
Type of output-Maximum admissible current (mA)	PNP	PNP	PNP
Maximum admissible current (mA)	50	50	50
IP65 over the whole motor apart from the shaft output. Versions with brake are IP20			
<b>Accessory</b>			
2 metre shielded cable with 12-pin female M16 connector			<b>15275008</b>

Product made to order

## Curves

Speed / Torque 80140 TNi21 - Current / Torque 80140 TNi21

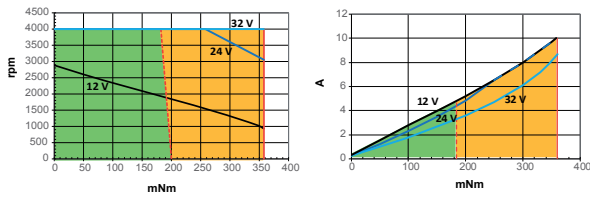

Speed / Torque 80180 TNi21 - Current / Torque 80180 TNi21

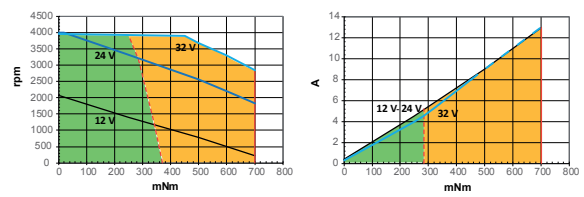

Speed / Torque 80280 TNi21 - Current / Torque 80280 TNi21

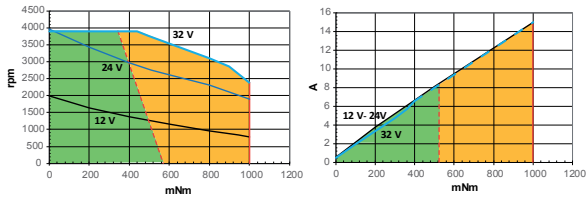

- Continuous running area
- Cycling running area
- ⋯ Maximum continuous torque
- Maximum peak torque

## Dimensions (mm)

Cable output versions

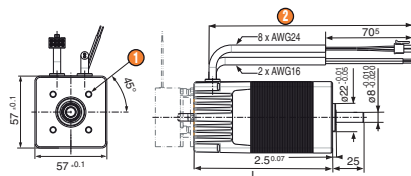

M16 connector version - 12 pins

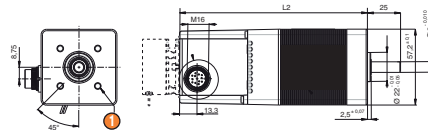

L: 80140: 92 max  
L: 80180 / 80280: 112 max

L2: 80140: 123 max  
L2: 80180 / 80280: 143 max

More information: see page 16

## Connections

	Connector M16	Cable color
Power ground	G+M	AWG16 Blue
Power supply +12 to +32 V DC	E+F	AWG16 Brown
Logic ground	H	AWG24 Black (5)
Input 1: On/Off	C	AWG24 Green (1)
Input 2: Direction	B	AWG24 Yellow (2)
Input 3: Speed	J	AWG24 Orange (4)
Output 1: Tachometer*	A	AWG24 Brown (6)
Output 2: Real direction	L	AWG24 Red (8)
Input 4: Torque	D	AWG24 Blue (3)
Output 3: Torque at max.	K	AWG24 Purple (7)

\* 12 p/rev. and 24 for 80280 motor

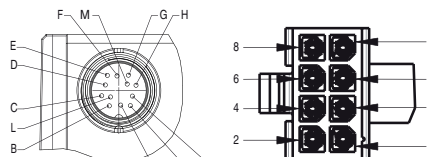

## Options

Holding brake 0.5 Nm - 24 V---

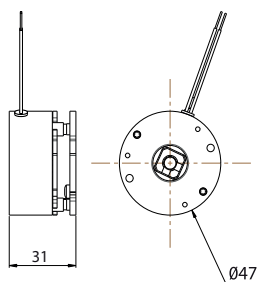

- › Shaft, pinion, pulley dimensions
- › Cable wire length
- › Powerful controlled brake (directed)
- › Programs evolution

## User information

Notice available on website, please read it before use.

# DCmind: BRUSHLESS MOTORS

## Motors 34 to 192 W nominal output power range with SMi21 Position, Speed and Torque Control

- › Servomotor for position, speed and torque control applications
- › Very high power density
- › Built-in electronics with 6 inputs (2 of which are analog) and 4 outputs
- › Built-in 4096-pulse encoder
- › With application programs already preset and saved in the motor
- › Expert programs can be used to adapt to the requirements of difficult applications
- › Parameters set on the PC via USB connection
- › Integrated bootloader for embedding special customer firmware



### Parts number

	34 to 94 W			40 to 145 W			82 to 192 W		
Type	80140 SMi21			80180 SMi21			80280 SMi21		
<b>Part numbers</b>									
IP65 option	80140043			80180044			80280001		
Holding torque brake 0.5 Nm option	80140044			80180045			80280002		
Nominal operating range (V <sub>DC</sub> )	12 - 48			12 - 48			12 - 48		
Min. max. operating range (V <sub>DC</sub> )	9 - 56			9 - 56			9 - 56		
<b>No-load characteristics</b>	12 V <sub>DC</sub>	24 V <sub>DC</sub>	48 V <sub>DC</sub>	12 V <sub>DC</sub>	24 V <sub>DC</sub>	48 V <sub>DC</sub>	12 V <sub>DC</sub>	24 V <sub>DC</sub>	48 V <sub>DC</sub>
Speed of rotation (rpm)	2400	4000	4000	1700	3500	4000	1500	3050	4000
Absorbed current (A)	0.3	0.3	0.2	0.3	0.33	0.2	0.38	0.44	0.35
<b>Nominal characteristics</b>	12 V <sub>DC</sub>	24 V <sub>DC</sub>	48 V <sub>DC</sub>	12 V <sub>DC</sub>	24 V <sub>DC</sub>	48 V <sub>DC</sub>	12 V <sub>DC</sub>	24 V <sub>DC</sub>	48 V <sub>DC</sub>
Speed (rpm)	1460	3900	4000	1100	2900	4000	1100	2863	4000
Torque (mNm)	225	225	225	350	350	350	685	565	460
Absorbed current (A)	5.2	5.2	2.6	5.65	5.40	3.65	10	8	5
Output power (W)	34	92	94	40	105	145	82	170	192
<b>Maximal characteristics</b>	12 V <sub>DC</sub>	24 V <sub>DC</sub>	48 V <sub>DC</sub>	12 V <sub>DC</sub>	24 V <sub>DC</sub>	48 V <sub>DC</sub>	12 V <sub>DC</sub>	24 V <sub>DC</sub>	48 V <sub>DC</sub>
Speed of rotation (rpm)	1100	3000	4000	1000	2400	4000	740	2250	4000
Torque (mNm)	300	400	440	400	600	750	1000	1000	1000
Absorbed current (A)	7	9.5	6.1	6.4	10	10.1	14	14	11.5
Output power (W)	34	125	184	42	151	314	77	235	419
<b>General characteristics</b>									
Rotor inertia (gcm <sup>2</sup> )	75			115			120		
Number of rotor poles	4			4			8		
Ambient operating temperature (°C)	-30 → +70			-30 → 70			-30 → +70		
Service life (h)	20000			20000			20000		
Ball bearing	✓			✓			✓		
Weight (kg)	1.17			1.52			1.62		
<b>Integrated software</b>									
Applications software	✓			✓			✓		
Positioning mode	✓			✓			✓		
Speed mode	✓			✓			✓		
Torque mode	✓			✓			✓		
<b>Inputs / Outputs</b>									
Analog inputs (PWM and 0-10 V)	2			2			2		
Digital inputs	4			4			4		
(PWM) output	2			2			2		
Digital output	2			2			2		
IP65 over the whole motor apart from the shaft output. Versions with brake are IP20									
<b>Accessory</b>									
Starter kit, DCmind soft program and USB cable							79298008		

### Product adaptations



- › Other specific applications software
- › Specific PC interface
- › Special cable length
- › Special shaft
- › Other connectors

Product made to order

## Curves

Speed / Torque 80140 SMi21- Current / Torque 80140 SMi21

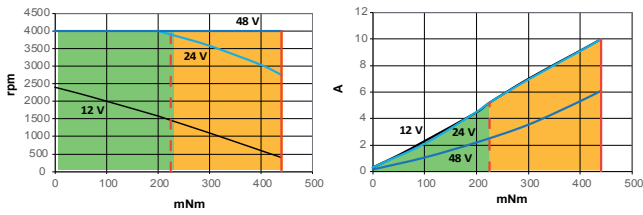

Speed / Torque 80180 SMi21 - Current / Torque 80180 SMi21

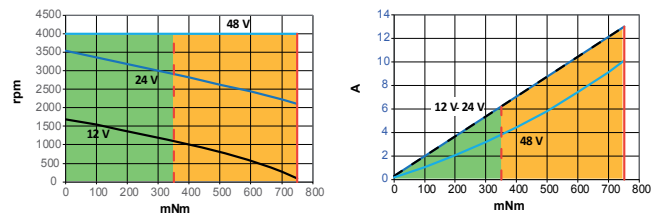

Speed / Torque 80280 SMi21- Current / Torque 80280 SMi21

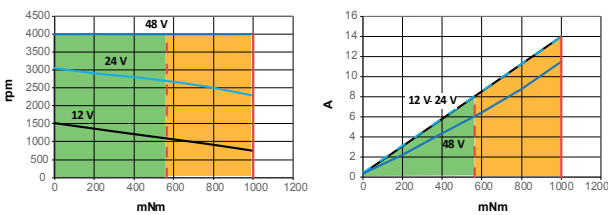

- Continuous running area
- Cycling running area
- ⋯ Maximum continuous torque
- Maximum peak torque

## Dimensions (mm)

80140 - 80180 - 80280 SMi21

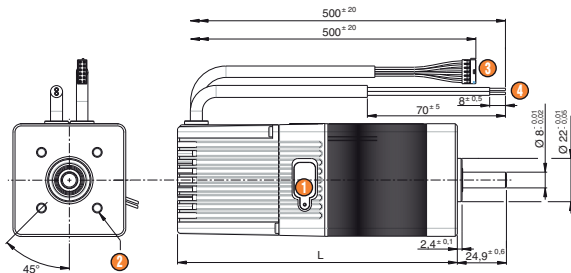

- ① USB connection type B
- ② 4 x M5 over Ø 40 depth 4.5
- ③ Command cable 12 x AWG26
- ④ Power cable 2 x AWG16

L: 80140: 123 max  
L: 80180 / 80280: 143 max

More information: see page 16

## Connection

Connector (Molex 0430251200)

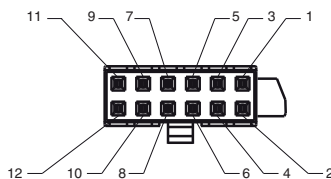

Pin	Logic cable	
	Description	Wires color
1	Input 1 - logic	Green
2	Input 2 - logic	Yellow
3	Input 3 - logic	White
4	Input 4 - logic	White-brown
5	Input 5 - analog	Blue
6	Input 6 - analog	Orange
7	0 V <sub>---</sub>	Black
8	0 V <sub>---</sub>	White-black
9	Output 1 - PWM	Brown
10	Output 2 - PWM	Purple
11	Output 3 - logic	Reed
12	Output 4 - logic	Grey

Power cable	
Description	Wires color
+12 V <sub>---</sub> ↔ 48 V <sub>---</sub>	Brown
0 V <sub>---</sub>	Blue

## User information

Notice available on website, please read it before use.

# GEARBOXES FOR DCmind BRUSHLESS RANGE

## 4 to 120 Nm

- › Planetary and worm gearboxes
- › Shafts on ball bearings
- › Long service life
- › IP65



### Part numbers

Gearboxes	Planetary Ø 52			Planetary Ø 62			Planetary Ø 81			Worm
Type	810495			810496			810497			810410
Associated motors	Part number			Part number			Part number			Part number
80140 TNi21	801495 TNi21			801496 TNi21			801897 TNi21			801410 TNi21
80180 TNi21				801896 TNi21			802897 TNi21			801810 TNi21
80280 TNi21										802810 TNi21
80140 SMi21	801495 SMi21			801496 SMi21						801410 SMi21
80180 SMi21				801896 SMi21			801897 SMi21			801810 SMi21
80280 SMi21							802897 SMi21			802810 SMi21
Gearbox characteristics										
Number of stages	1	2	3	1	2	3	1	2	3	1
Maximum permitted torque (Nm)	4	12	25	8	25	50	20	60	120	10
Efficiency	0.8	0.75	0.7	0.9	0.8	0.7	0.9	0.8	0.7	0.6 → 0.3
Axial dynamic load (daN)	6	10	15	7	10	15	8	12	20	10
Radial dynamic load (daN)	20	32	45	24	36	52	40	60	100	15
Operating temperature	-20 → +70°C			-20 → +70°C			-20 → +70°C			-20 → +70°C
Weight (kg)	0.7	0.8	1.1	0.8	1.2	1.6	1.8	2.5	3.2	0.7
Standard reduction ratios	6.75	25	93	5.16	19	100	5	19	100	5 - 10 - 20 - 30 - 50
		46	169	6.75	27	139		27	139	
			308		46	308			236	
Other ratios possible										15 - 100
Comments										

**Ø 52 planetary gearbox:** Metal gears on all stages. IP65 apart from the output shaft.

**Ø 62 planetary gearbox:** On the first stage, the planet gears are made of composite materials which improve efficiency and service life. On the other stages, the metal gears turn on needle bearings. IP65 apart from the output shaft.

**Ø 81 planetary gearbox:** All gears are metal and turn on needle bearings, resulting in excellent robustness and a very long service life. IP65 apart from the output shaft.

**Worm gearbox:** This gearbox combines a tempered steel worm and a hard bronze helical gear wheel, thus ensuring a long service life. The wheel is coated with grease, ensuring an excellent slip coefficient and good heat dissipation. O-rings and lipseals are used in combination with a compression spring to create a tight seal at the gearbox output shaft and the motor input shaft. IP65 gearbox.

The casing is made of aluminium to maximise heat exchanges with its supporting surface on the machine. However, due to the high power that can be transmitted by this gearbox and the low efficiency inherent in large worm gearbox reduction ratios, make sure that the gearbox casing temperature does not exceed 75°C during operation.

The output shaft can be placed on the right or left, or can be a double shaft (shaft output on both sides).

### Made to order products, available on request



- › Special shafts
- › Other reduction ratios
- › Other fixing holes
- › Special mounting flange

Product made to order



**Dimensions (mm)**

**Planetary gearbox Ø 52 (810495)**

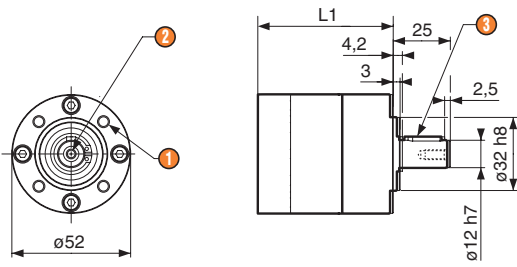

- 1 4 x M5 at 90°, depth 10 over  $\varnothing 40$
- 2 M4 x 10
- 3 Parallel key 4 x 4 x 16 DIN 6885 A

L1 1 stage:  $55.3 \pm 0.5$   
 L1 2 stages:  $69.5 \pm 0.5$   
 L1 3 stages:  $83.7 \pm 0.5$

**Planetary gearbox Ø 62 (810496)**

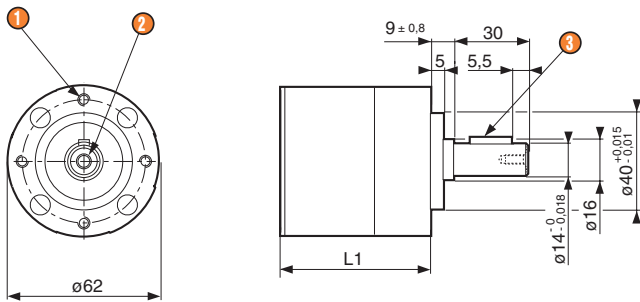

- 1 4 x M5 at 90°, depth 10 over  $\varnothing 52$
- 2 M5, depth 12.5
- 3 Parallel key 5 x 5 x 18 DIN 6885 A

L1 1 stage:  $52.1 \pm 0.7$   
 L1 2 stages:  $67.9 \pm 0.7$   
 L1 3 stages:  $83.8 \pm 0.7$

**Planetary gearbox Ø 81 (810497)**

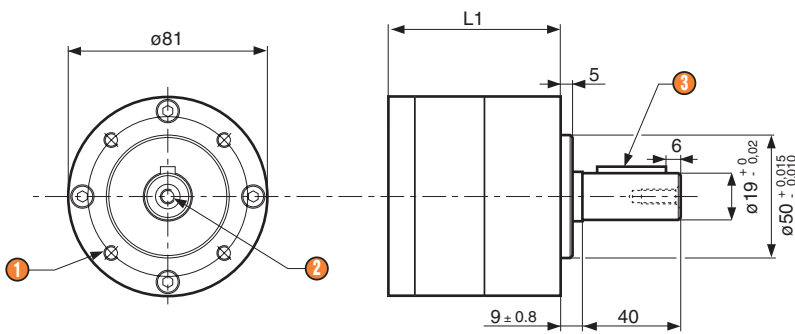

- 1 4 x M6, depth 12 over  $\varnothing 65$
- 2 M6 x 16
- 3 Parallel key 6 x 6 x 28 DIN 6885 A

L1 1 stage:  $70.5 \pm 0.6$   
 L1 2 stages:  $92.2 \pm 0.6$   
 L1 3 stages:  $113.8 \pm 0.6$

**Worm gearbox RAD10 (810410)**

Version with output shaft on left

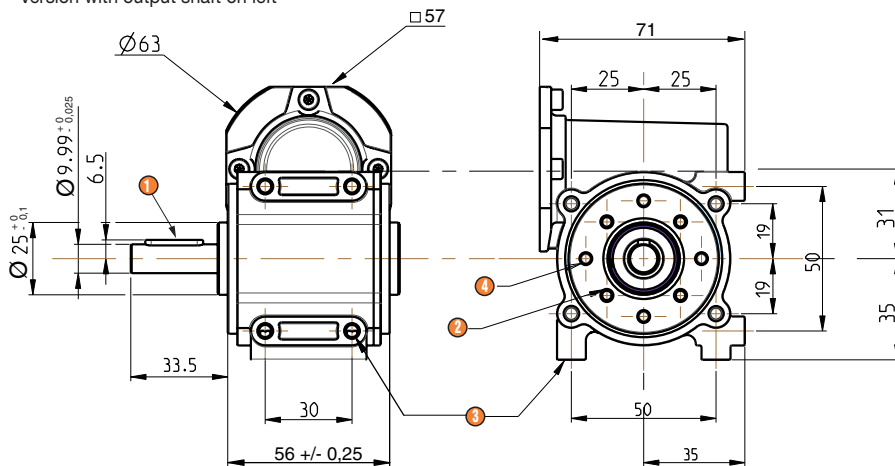

- 1 Parallel key 4 x 4 x 20 DIN6885
- 2 4 x M4, depth 8 over  $\varnothing 36$
- 3 8 x M5, depth 8
- 4 4 x  $\varnothing 3.8$  depth 10 over  $\varnothing 40$

The left-hand and right-hand sides of the gearbox are identical.

# DCmind BRUSHLESS DIRECT MOTOR TNi21 & SMi21 CABLE OUTPUT OR WITH CONNECTOR M16

## Dimensions (mm)

80140 - 80180 - 80280 - TNi21 version output cable with or without brake

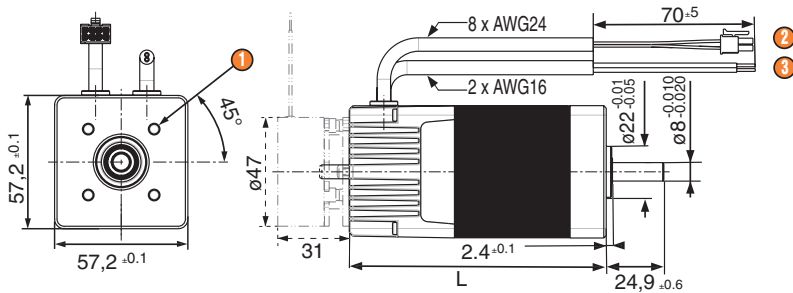

L 80140: 92 max.  
L 80180: 112 max.  
L 80280: 112 max.

- 1 4 x M5 at 90°, depth 6 over Ø 40
- 2 Command cable 8 x AWG24 / 500 mm
- 3 Power cable 2 x AWG16 / 500 mm

80140 - 80180 - TNi21 version connector M16 - 12 pins with or without brake

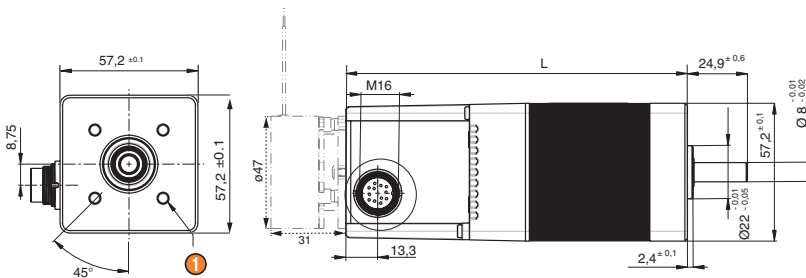

L 80140: 123 max.  
L 80180: 143 max.

- 1 4 x M5 at 90°, depth 6 over Ø 40

80140 - 80180 - 80280 - SMi21 with or without brake

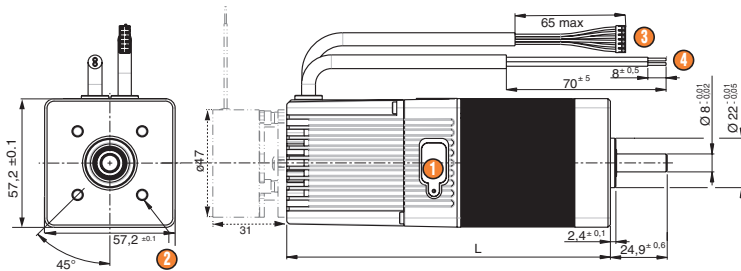

L 80140: 123 max.  
L 80180: 143 max.  
L 80280: 143 max.

- 1 USB connection type B
- 2 4 x M5 at 90°, depth 6 over Ø 40
- 3 Command cable 10 x AWG24 / 500 mm
- 4 Power cable 2 x AWG16 / 500 mm

# DCmind BRUSHLESS GEARED MOTOR TNi21

## CABLE OUTPUT

### Dimensions (mm)

801495 - TNi21 + P52 with or without brake

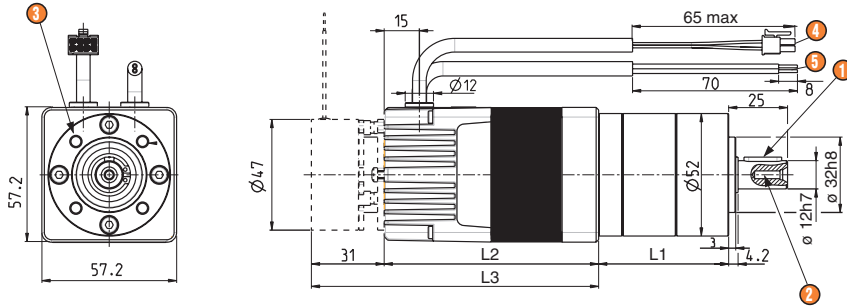

L1 1 stage: 55.3 ±0.5  
 L1 2 stages: 69.5 ±0.5  
 L1 3 stages: 83.7 ±0.5

L2 80140: 92 max.

L3 80140: 123 max.

- 1 Parallel key 4 x 4 x 16 DIN 6885 A
- 2 M4 x 10
- 3 4 x M5 at 90°, depth 10 over Ø 40
- 4 Command cable 8 x AWG24 / 500 mm
- 5 Power cable 2 x AWG16 / 500 mm

801496 - 801896 - TNi21 + P62 with or without brake

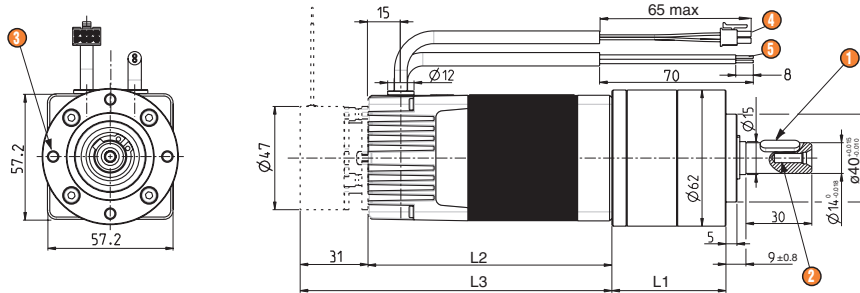

L1 1 stage: 52.1 ±0.7  
 L1 2 stages: 67.9 ±0.7  
 L1 3 stages: 83.8 ±0.7

L2 80140: 92 max.

L2 80180: 112 max.

L3 80140: 123 max.

L3 80180: 143 max.

- 1 Parallel key 5 x 5 x 18 DIN 6885 A
- 2 M5 x 12
- 3 4 x M5 at 90°, depth 10 over Ø 52
- 4 Command cable 8 x AWG24 / 500 mm
- 5 Power cable 2 x AWG16 / 500 mm

801897 - 802897 - TNi21 + P81 with or without brake

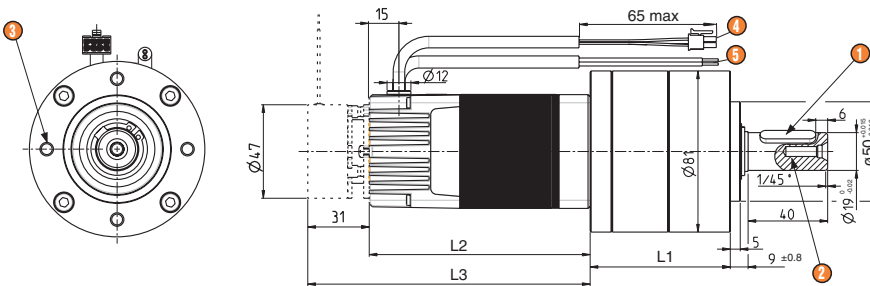

L1 1 stage: 70.5 ±0.6  
 L1 2 stages: 92.2 ±0.6  
 L1 3 stages: 113.8 ±0.6

L2 80180-80280: 112 max.

L3 80180-80280: 143 max.

- 1 Parallel key 6 x 6 x 28 DIN 6885 A
- 2 M6 x 16
- 3 4 x M6 at 90°, depth 12 over Ø 65
- 4 Command cable 8 x AWG24 / 500 mm
- 5 Power cable 2 x AWG16 / 500 mm

801410 - 801810 - 802810 - TNi21 + RAD10 with or without brake

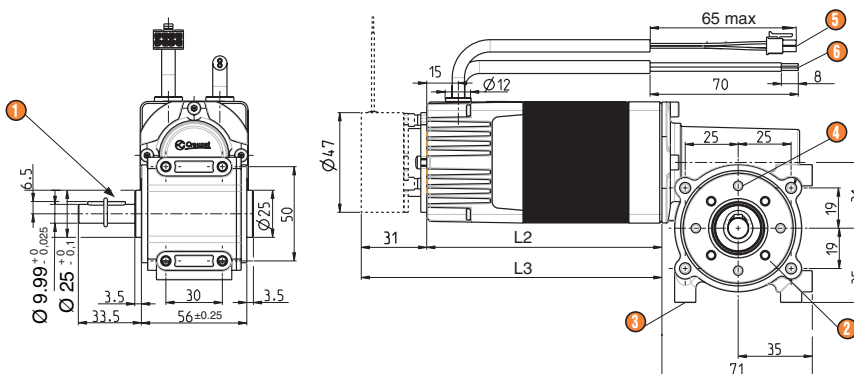

L2 80140: 92 max.  
 L2 80180-80280: 112 max.

L3 80140: 123 max.  
 L3 80180-80280: 143 max.

- 1 Parallele key 4 x 4 x 20 DIN 6885 A
- 2 4 x M4, depth 8 over Ø 36
- 3 8 x M5 depth 8
- 4 4 x Ø 3.8, depth 10 over Ø 40
- 5 Command cable 8 x AWG24 / 500 mm
- 6 Power cable 2 x AWG16 / 500 mm

# DCmind BRUSHLESS GEARED MOTOR TNi21 WITH CONNECTOR M16

## Dimensions (mm)

801495 - TNi21 + P52 M16 connector with or without brake

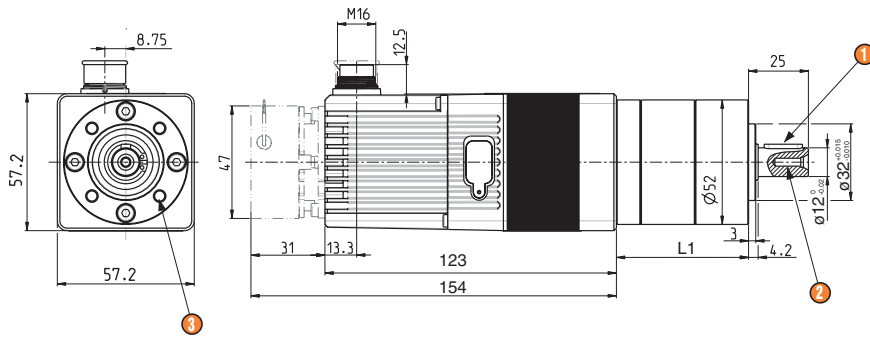

- L1 1 stage: 55.3 ±0.5
- L1 2 stages: 69.5 ±0.5
- L1 3 stages: 83.7 ±0.5

- 1 Parallel key 4 x 4 x 16 DIN 6885 A
- 2 M4 x 10
- 3 4 x M5 at 90°, depth 10 over Ø 40

801496 - 801896 - TNi21 + P62 M16 connector with or without brake

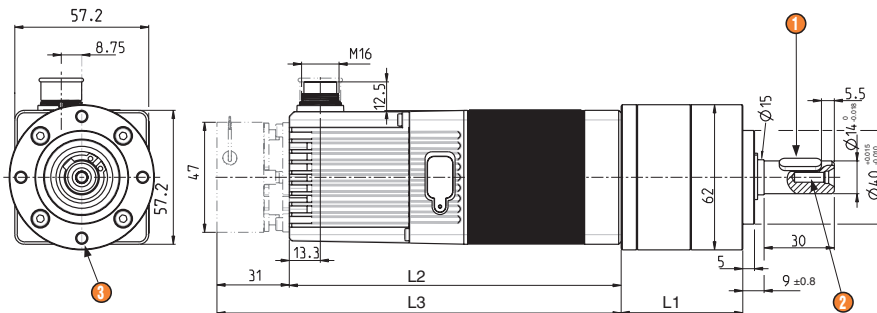

- L1 1 stage: 52.1 ±0.7
- L1 2 stages: 67.9 ±0.7
- L1 3 stages: 83.8 ±0.7

- L2 80140: 123 max.
- L2 80180: 143 max.
- L3 80140: 154 max.
- L3 80180: 174 max.
- 1 Parallel key 5 x 5 x 18 DIN 6885 A
- 2 M5 x 12
- 3 4 x M5 at 90°, depth 10 over Ø 52

801897 - TNi21 + P81 M16 connector with or without brake

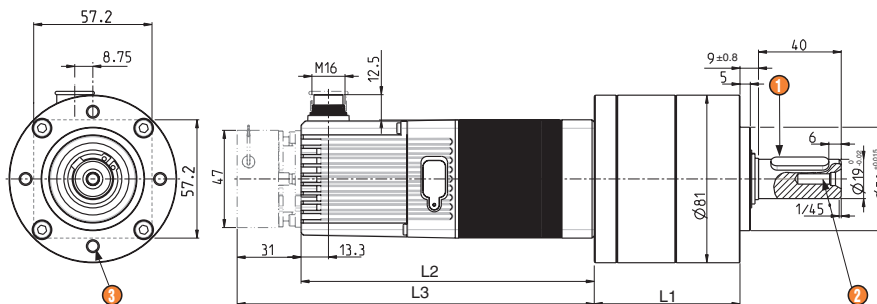

- L1 1 stage: 70.5 ±0.6
- L1 2 stages: 92.2 ±0.6
- L1 3 stages: 113.8 ±0.6

- L2 80180: 143 max.
- L3 80180: 174 max.
- 1 Parallel key 6 x 6 x 28 DIN 6885 A
- 2 M6 x 16
- 3 4 x M6, depth 12 over Ø 65

801410 - 801810 - TNi21 + RAD10 M16 connector with or without brake

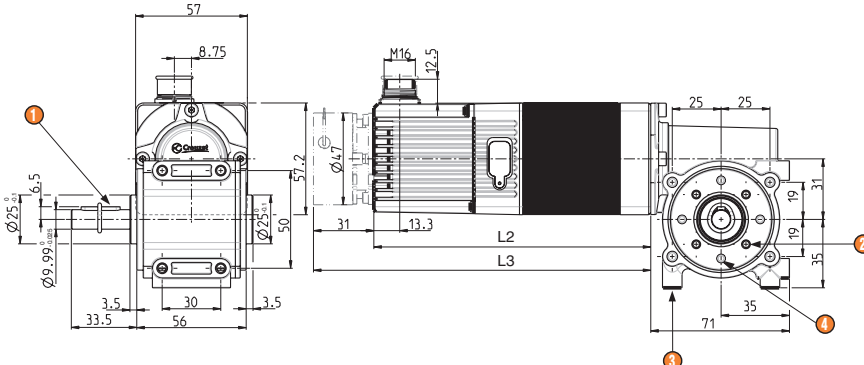

- L2 80140: 123 max.
- L2 80180-80280: 143 max.
- L3 80140: 154 max.
- L3 80180-80280: 174 max.

- 1 Parallel key 4 x 4 x 20 DIN 6885 A
- 2 4 x M4, depth 8 over Ø 36
- 3 8 x M5, depth 8
- 4 4 x 3.8, depth 10 over Ø 40

# DCmind BRUSHLESS GEARED MOTOR SMi21

## CABLE OUTPUT

### Dimensions (mm)

801495 - SMi21 + P52 with or without brake

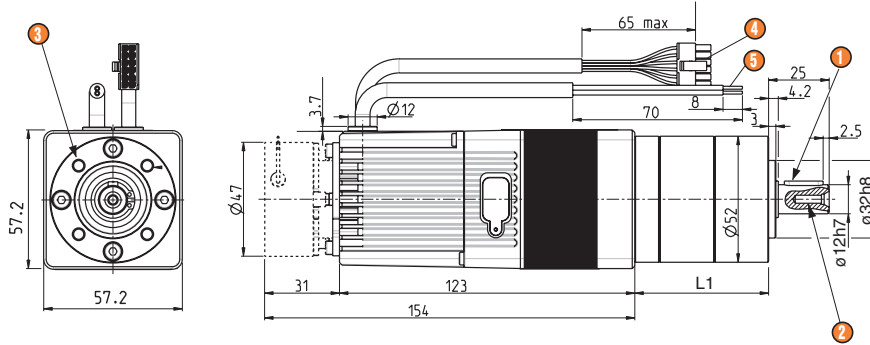

L1 1 stage: 55.3 ±0.5  
 L1 2 stages: 69.5 ±0.5  
 L1 3 stages: 83.7 ±0.5

- 1 Parallel key 4 x 4 x 16 DIN 6885 A
- 2 M4 x 10
- 3 4 x M5 at 90°, depth 10 over  $\phi 40$
- 4 Command cable 12 x AWG26 / 500 mm
- 5 Power cable 2 x AWG16 / 500 mm

801496 - 801896 - SMi21 + P62 with or without brake

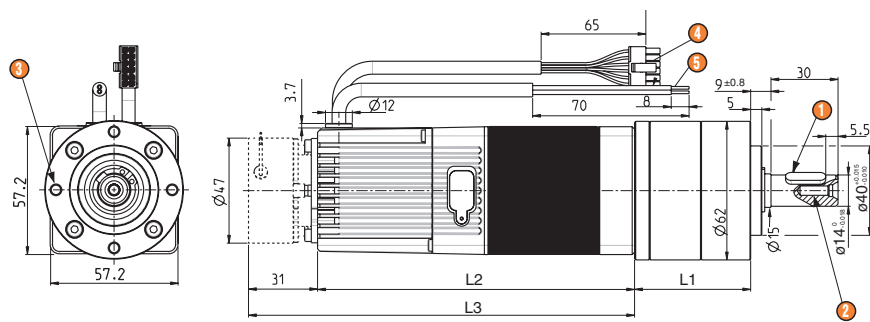

L1 1 stage: 52.1 ±0.7  
 L1 2 stages: 67.9 ±0.7  
 L1 3 stages: 83.8 ±0.7

- L2 80140: 123 max.
- L2 80180: 143 max.
- L3 80140: 154 max.
- L3 80180: 174 max.
- 1 Parallel key 5 x 5 x 18 DIN 6885 A
- 2 M5 x 12
- 3 4 x M5 at 90°, depth 10 over  $\phi 52$
- 4 Command cable 12 x AWG26 / 500 mm
- 5 Power cable 2 x AWG16 / 500 mm

801897 - 802897 - SMi21 + P81 with or without brake

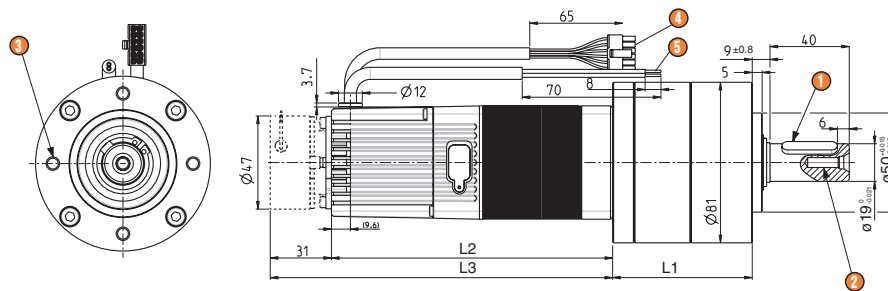

L1 1 stage: 70.5 ±0.6  
 L1 2 stages: 92.2 ±0.6  
 L1 3 stages: 113.8 ±0.6

- L2 80180 - 80280: 143 max.
- L3 80180 - 80280: 174 max.
- 1 Parallel key 6 x 6 x 28 DIN 6885 A
- 2 M6 x 16
- 3 4 x M6 at 90°, depth 12 over  $\phi 65$
- 4 Command cable 12 x AWG26 / 500 mm
- 5 Power cable 2 x AWG16 / 500 mm

801410 - 801810 - 802810 - SMi21 + RAD10 with or without brake

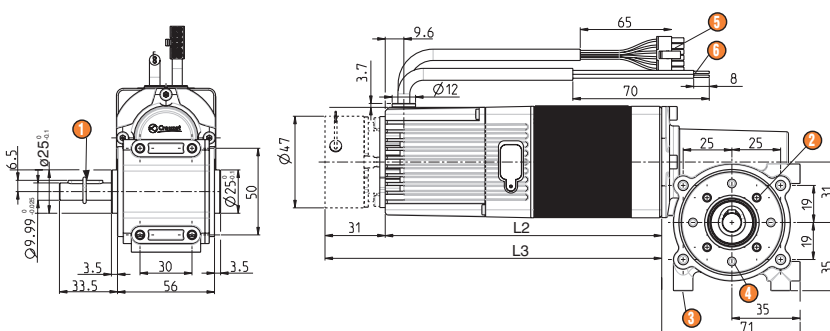

L2 80140: 123 max.  
 L2 80180 - 80280: 143 max.  
 L3 80140: 154 max.  
 L3 80180 - 80280: 174 max.

- 1 Parallel key 4 x 4 x 20 DIN 6885 A
- 2 4 x M4, depth 8 over  $\phi 36$
- 3 8 x M5, depth 8
- 4 4 x  $\phi 3.8$ , depth 10 over  $\phi 40$
- 5 Command cable 12 x AWG26 / 500 mm
- 6 Power cable 2 x AWG16 / 500 mm

## AMERICAS

### CANADA

**InnoVista Sensors™**  
1461 Lawrence Drive  
Thousand Oaks, CA 91320  
USA  
Tel.: +1 (800) 677 5311  
Fax: +1 (619) 923 2088  
dcmind@crouzet.com

### MEXICO

**InnoVista Sensors™**  
Calzada Zavaleta 2505-C  
Santa Cruz Buenavista  
Puebla, 72150 - MEXICO  
Tel.: +52 (222) 409 7000  
mexico@crouzet.com

### USA

**InnoVista Sensors™**  
1461 Lawrence Drive  
Thousand Oaks, CA 91320  
USA  
Tel.: +1 (800) 677 5311  
Fax: +1 (619) 923 2088  
dcmind@crouzet.com

### COUNTRIES NOT LISTED

**InnoVista Sensors™**  
1461 Lawrence Drive  
Thousand Oaks, CA 91320  
USA  
Tel.: +1 (800) 677 5311  
Fax: +1 (619) 923 2088  
dcmind@crouzet.com

## EUROPE / MIDDLE EAST / AFRICA

### BELGIUM

**InnoVista Sensors™**  
Dieweg 3 B  
1180 Uccle - BELGIQUE  
Tel.: +32 (0) 2 462 07 30  
Fax: +32 (0) 2 461 00 23  
kiantenservice@crouzet.com

### FRANCE

**InnoVista Sensors™**  
2 rue du Docteur Henri Abel,  
CS 60059  
26902 Valence Cedex 9  
FRANCE  
Tel.: +33 (0) 475 802 101  
Fax: +33 (0) 475 828 900  
relationclient@crouzet.com

### GERMANY / AUSTRIA

**InnoVista Sensors™**  
Otto-Hahn-Str. 3  
40721 Hilden  
DEUTSCHLAND  
Tel.: +49 (0) 2103/980-0  
Fax: +49 (0) 2103/980-222  
kundenservice@crouzet.com

### ITALY

**InnoVista Sensors™**  
Via Viganò De Vizzi, 93/95  
20092 Cinisello Balsamo (MI)  
ITALIA  
Tel.: +39 (02) 66 599 211  
Fax: +39 (02) 66 599 218  
assistenzaclienti@crouzet.com

### SPAIN / PORTUGAL

**InnoVista Sensors™**  
C/Lleó, 11-13 2º4ª  
08911 Badalona - Barcelona  
ESPAÑA  
Tel.: +34 (93) 484 39 70  
Fax: +34 (93) 484 39 73  
atencionalcliente@crouzet.com

### SWITZERLAND

**InnoVista Sensors™**  
Gewerbepark - Postfach 56  
5506 Mägenwil - SCHWEIZ  
Tel.: +49 (0) 2103/980-0  
Fax: +49 (0) 2103/980-222  
kundenservice@crouzet.com

### THE NETHERLANDS

**InnoVista Sensors™**  
Industrieweg 17  
2382 NR Zoeterwoude  
NEDERLAND  
Tel.: +31 (0) 71-581 20 30  
Fax: +31 (0) 71-541 35 74  
kiantenservice@crouzet.com

### COUNTRIES NOT LISTED

**InnoVista Sensors™**  
2 rue du Docteur Henri Abel,  
CS 60059  
26902 Valence Cedex 9  
FRANCE  
Tel.: +33 (0) 475 802 102  
Fax: +33 (0) 475 828 900  
customer.relation@crouzet.com

## ASIA / PACIFIC

### CHINA

**InnoVista Sensors™**  
11<sup>th</sup> floor, Chang Feng  
International Tower,  
89 Yunling Road (East),  
Putuo District,  
Shanghai 200 062 - CHINA  
Tel.: +86 (21) 8025 7166  
Fax: +86 (21) 6107 1771  
china@crouzet.com

### INDIA

**InnoVista Sensors™**  
4<sup>th</sup> floor, Trident Towers, #23 100  
Feet Ashoka Pillar Road,  
2nd Block, Jaynagar  
Bangalore 560 011 - INDIA  
Tel.: +91 (80) 4113 2204/05  
Fax: +91 (80) 4113 2206  
india@crouzet.com

### SOUTH KOREA

**InnoVista Sensors™**  
14F, Kbiz DMC Tower,  
189, Seongam-Ro, Mapo-Gu,  
Seoul 121-904  
SOUTH KOREA  
Tel.: +82 (2) 2629 8312  
Fax: +82 (2) 2630 9800  
korea@crouzet.com

### EAST ASIA PACIFIC

**InnoVista Sensors™**  
10/F, Wharf T&T Centre, Harbour  
City, 7 Canton Road, Tsim Sha Tsui,  
Kowloon, HONG KONG  
Tel.: +86 (21) 8025 7177  
Fax: +86 (21) 6107 1771  
eap@crouzet.com

[WWW.CROUZET-MOTORS.COM](http://WWW.CROUZET-MOTORS.COM)



[WWW.INNOVISTASENSORS.COM](http://WWW.INNOVISTASENSORS.COM)



### Warning:

The product information contained in this catalogue is given purely as information and does not constitute a representation, warranty or any form of contractual commitment. Crouzet Automatismes SAS and its subsidiaries reserve the right to modify their products without notice. It is imperative that we should be consulted over any particular use or application of our products and it is the responsibility of the buyer to establish, particularly through all the appropriate tests, that the product is suitable for the use or application. Under no circumstances will our warranty apply, nor shall we be held responsible for any application (such as any modification, addition, deletion, use in conjunction with other electrical or electronic components, circuits or assemblies, or any other unsuitable material or substance) which has not been expressly agreed by us prior to the sale of our products.