

LED DRIVER PRODUCTS



COMPANY OVERVIEW

Diodes Incorporated is a leading global provider of Discrete, Analog, and Logic semiconductors.

Its global footprint includes sales offices in five countries and manufacturing locations in China, Europe and the USA.

A focus on product innovation, cost reduction, acquisitions and customer service has made Diodes Incorporated an industry leader.



Combining leading silicon and packaging technologies, Diodes provides a broad portfolio of Discrete semiconductors comprising Bipolar Transistors, MOSFETs, Schottky diodes, SBR®, switching diodes and functional specific arrays to enable our customers' next generation designs.

The Diodes' Analog IC portfolio consists of six main areas: Power Management ICs, Standard Linear, Lighting, Sensors, Direct Broadcast by Satellite and Application-Specific Standard Products.

Diodes IC portfolio also includes Standard Logic products.

SOLUTIONS FOR LED LIGHTING APPLICATIONS

Diodes Incorporated's LED lighting solutions are not only recognized for their high efficiency and simplicity, but also for their flexibility and versatility.

The best Analog ICs provide circuit designers with the most advantageous combination of efficiency, functionality and package size.

Diodes has a wide variety of types of LED drivers: high voltage offline, DC-DC switching, charge pump and linear LED drivers that are well suited for a wide range of applications.

- General lighting
- Signage and display
- Portable lighting
- Automotive

Diodes provides a wide range of tools to aid the design-in of our LED drivers; these include Excel component value calculators as well as evaluation modules—both general-purpose and application-specific—see page 18 for a list.

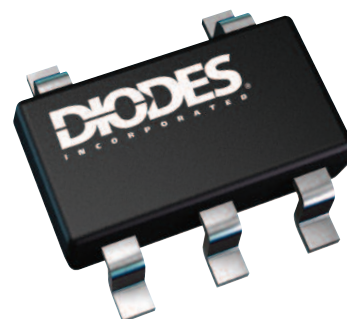

This selection guide covers Diodes' line of LED drivers and their markets/application areas:

Diodes' family of LED drivers provides high-efficiency constant current drive for high-brightness LEDs—both high and low current. When driving multiple LEDs in a single string, efficiencies greater than 95% may be attained together with very accurate LED current matching.

Diodes' offline LED drivers provide a simple cost-effective solution for offline lamps, which includes retrofit lamps as well as T5/T8/T10/T12 replacements.

Diodes' medium voltage DC-DC high-brightness LED drivers combine a small footprint and high-power density with operating voltage up to 60V. Integrated switch LED drivers are capable of delivering LED currents up to 1.5A. Device topologies include buck, boost and buck-boost.

Diodes' low voltage DC-DC high-brightness LED drivers are targeted at battery-powered systems for general illumination applications.

Diodes provides small screen display illumination with high-efficiency charge pump multi-channel LED drivers and inductive boost LED drivers. High-efficiency and high-switching frequencies make them well suited to modern portable consumer equipment.

Diodes' linear LED drivers provide a simple cost-effective solution to driving low-current, high-brightness LEDs.



INDEX

Offline LED Drivers	4
Offline LED Driver Applications	4
E14/B10 Lamps	4
A19/E27 Lamps	5
T5/T8/T10/T12 Lamps	5
Medium Voltage DC-DC LED Drivers	6
Medium Voltage Applications	7–9
General Illumination	
LED Lamp Solution for Refrigerators	7
MR16 LED Lamp Solution	8
High-Power MR16 Lamps	8
LED Lamp Solution for Street Lights	9
LED Lamp Solution for Wall Washers	9
Low Voltage DC-DC LED Drivers	10
Low Voltage Applications	11–12
Portable Lighting	
2-Cell Flashlight	11
Portable LED Projector	11
Signage and Display	
Single-Cell Emergency Lighting	12
General Illumination	
Simple Solar Exterior Lights	12
Linear LED Drivers	13
Linear LED Driver Applications	13
Signs	13
Automotive LED Drivers	14
Automotive Lighting Applications	14–15
Interior Lamps	14
Door Lighting	15
Daytime Running Lights	15
Backlighting ICs and Bias Generators	16
LED Backlight Drivers	16
LCD and OLED Bias Generators	16
Small Screen Display Applications	17
5" PND Screen	17
3" Mobile Screen	17
LED Driver Evaluation Boards	18
Drivers for Industry-Standard LEDs	19



Offline LED Drivers

Part Number	Minimum Input Voltage	Maximum Input Voltage	V _{DD}	Output Current	LED Current	Accuracy	Switching Frequency	Efficiency	Dimming		OTP Temperature	Supply Current	Temperature Range	Available Packages
	V	V	V	mA	A	%	kHz	%	PWM	Analog	°C	mA	°C	
AL9910	15	500	7.5	10	External MOSFET	10	300	90	Y	Y	150	0.5	-40 to +85	SO-8
													-40 to +105	SO-8EP
AL9910-5	15	500	7.5	10	External MOSFET	5	300	90	Y	Y	150	0.5	-40 to +85	SO-8
													-40 to +105	SO-8EP
AL9910A	20	500	10	10	External MOSFET	10	300	90	Y	Y	150	0.65	-40 to +85	SO-8
													-40 to +105	SO-8EP



Simple, versatile solutions for LED driving

THE DIODES ADVANTAGE

AL9910 Benefits

- **Exposed pad SO-8 and standard SO-8**
Improved power dissipation reduces temperature rise
Improved reliability over standard solutions
- **Over-temperature protection**
Increases reliability of lamps
- **500V maximum input voltage**
Exceeds requirements for 277V_{AC} main voltages
- **Internal regulator with two output voltage variants**
Removes need for start-up bleed resistor
AL9910: 7.5V V_{DD} → MOSFETs with V_{GS(MAX)}<12V
AL9910A: 10V V_{DD} → MOSFETs with V_{GS(MAX)}<20V
- **Separate linear and PWM dimming inputs**
LD Pin → dimming, thermal control, better accuracy
PWM_D is TTL compatible → better resolution

Offline LED Driver Applications

E14/B10 High PF Retrofit LED Lamps



For retrofit E14/B10 replacement lamps a small-footprint, high-power factor solution is required.

The AL9910 provides a versatile cost-effective solution to these non-dimmable lamps.

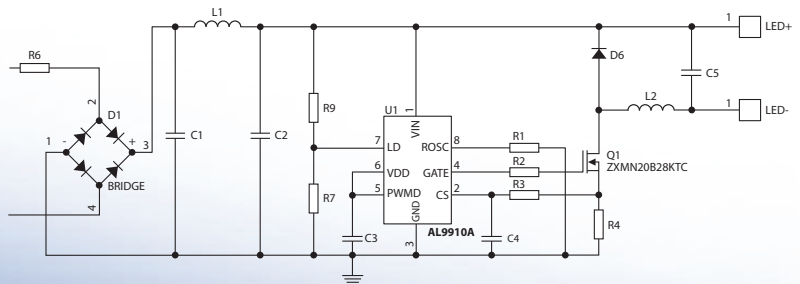

THE DIODES ADVANTAGE

AL9910 Benefits

- **Integrated high-voltage regulator**
Removes high-power, start-up resistor
- **Uses LD pin to increase power factor**
Reduces size of bulk capacitor
- **Exposed pad SO-8 reduces junction temperature**
Better reliability
- **500V maximum input voltage improves robustness from transients at 277V_{AC}**

Offline LED Driver Applications

A19/E27 Triac Dimmable Retrofit LED Lamps



For retrofit A19/E27 replacement lamps a small footprint high-power factor solution that is triac dimmable is required.

The AL9910 provides a versatile, cost-effective solution to these dimmable lamps.

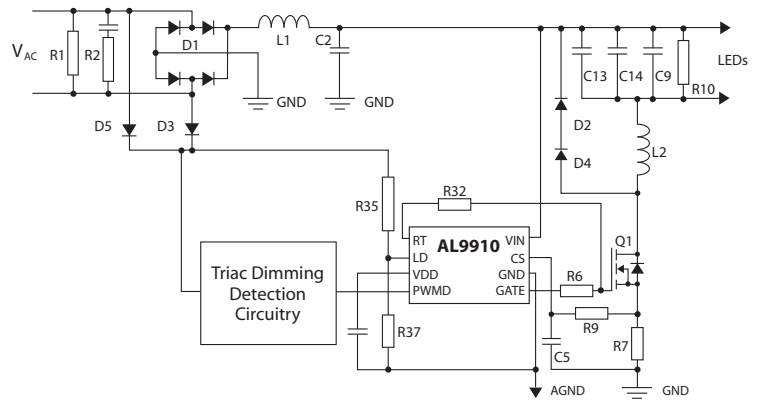

THE DIODES ADVANTAGE

AL9910 Benefits

- **Integrated high-voltage regulator**
Removes high-power start-up resistor
- **Uses LD pin to increase power factor**
Reduces size of bulk capacitor
- **Exposed pad SO-8 reduces junction temperature**
Better reliability
- **500V maximum input voltage improves robustness from transients at 277V_{AC}**
- **Triac dimmable solutions**
Simple triac dimming using standard low-cost external components

T5/T8/T10/T12 Lamps



The LED fluorescent replacements require instant starting, high-efficiency energy saving, long life span, flexible voltage (110~277V_{AC}), flicker-free lighting and low to moderate LED power.

For high LED count systems, AL9910/-5/A permit a greater flexibility of LED string composition, at lower cost implementation to expand to multiple strings.

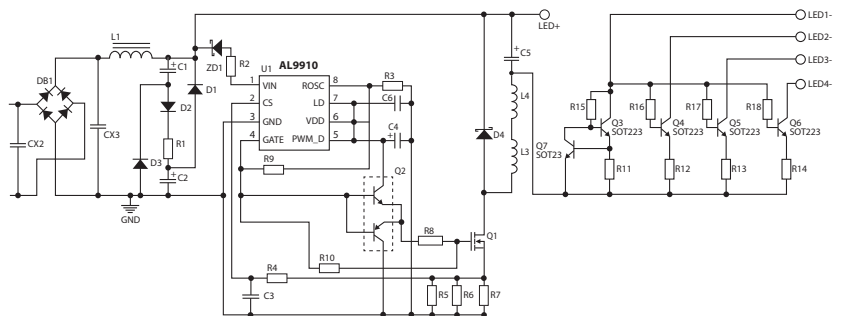

THE DIODES ADVANTAGE

AL9910-5 Benefits

- **Simple, multi-channel non-isolated LED driving**
Uses low-cost standard component to drive multiple low-current LED chains ideally suited to T5/T8/T10/T12 LED lamps
- **Exposed pad SO-8 and standard SO-8**
Improved power dissipation reduces temperature rise
Improved reliability over standard solutions
- **Over-temperature protection**
Increases reliability of lamps
- **500V maximum input voltage**
Exceeds requirements for 277V_{AC} main voltages
- **5% V_{CS} tolerance**
Improves LED current accuracy providing better inter-lamp matching

Medium Voltage DC-DC LED Drivers

Part Number	Topologies			Minimum Input Voltage	Maximum Input Voltage	Maximum Output Voltage	Maximum LED Current	LED Current Accuracy	Dimming		Maximum Switching Frequency	Efficiency	Operating Temperature Range	Sense Voltage	AEC-Q100 Grade	Available Packages
	Buck	Boost	Buck-Boost						PWM	Analog						
	V	V	V	A	%	kHz	%	°C	mV							
ZXLD1370	Y	Y	Y	6.5	60	Ext MOSFET		2	Y	Y	1000	97	-40 to +125	225	1	TSSOP-16EP
ZXLD1371	Y	Y	Y	5	60	Ext MOSFET		2	Y	Y	1000	97	-40 to +125	225	1	TSSOP-16EP
ZXLD1374	Y	Y	Y	6.5	60	60	1.5	2	Y	Y	1000	97	-40 to +125	225	1	TSSOP-20EP
ZXLD1366	Y	—	—	6	60	60	1	2.5	Y	Y	500	95	-40 to +125	200	1	TSOT25
															—	DFN3030-6
															1	SO-8EP
AP8802H	Y	—	—	8	60	60	1	5	Y	Y	600	95	-40 to +125	200	—	SO-8EP
ZXLD1362	Y	—	—	6	60	60	1	5	Y	Y	1000	95	-40 to +125	100	1	TSOT25
ZXLD1356	Y	—	—	6	60	60	0.55	2.5	Y	Y	1000	97	-40 to +125	200	1	TSOT25
															—	DFN3030-6
AP8802	Y	—	—	8	48	48	1	8	Y	Y	500	92	-40 to +105	200	—	SO-8, SO-8EP, DFN3030-10
AP8801	Y	—	—	8	48	48	0.5	8	Y	Y	500	92	-40 to +105	200	—	SO-8, MSOP-8
AL8806	Y	—	—	6	36	36	1.5	5	Y	Y	1000	98	-40 to +125	100	—	MSOP-8EP
AL8805	Y	—	—	6	36	36	1	5	Y	Y	1000	98	-40 to +125	100	—	SOT25
AL8807	Y	—	—	6	36	36	1	5	Y	Y	1000	98	-40 to +125	100	—	SOT25
							1.3									MSOP-8EP
AL8807A	Y	—	—	6	36	36	1	5	N	Y >10:1	700	98	-40 to +125	100	—	SOT25 (4Q12)
							1.3									MSOP-8EP
ZXLD1360	Y	—	—	7	30	30	1	5	Y	Y	1000	95	-40 to +125	100	1	TSOT25
ZXLD1350	Y	—	—	7	30	30	0.38	5	Y	Y	1000	95	-40 to +105	100	2	TSOT25
ZXLD1352	Y	—	—	7	30	30	0.38	5	Y	Y	1000	97	-40 to +105	100	2	TSOT25
AP8800A	Y	—	—	8	28	28	0.37	5	Y	Y	600	92	-40 to +105	100	—	TSOT25
AP8800	Y	—	—	8	28	28	0.35	7	Y	Y	600	92	-40 to +85	100	—	SO-8, MSOP-8, DFN3030-10



Medium Voltage DC-DC LED Drivers

Simple versatile solutions for LED driving

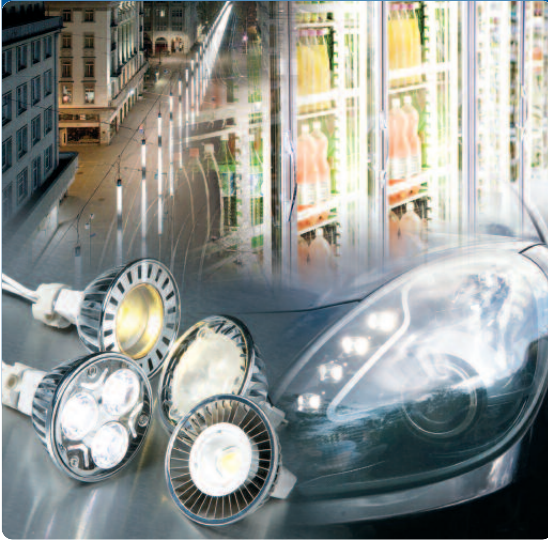

THE DIODES ADVANTAGE

Product Benefits

Simple solutions for driving multiple 1W and 3W LEDs in a variety of lighting applications

- **Equal ripple output current (hysteretic)**
Very simple design—only four external components required
Good stability—requires no external compensation
- **PWM and Analog dimming**
Versatile dimming; Analog for thermal and PWM for brightness control
- **ZXLD135x/6x in common footprint**
High-power density, small footprint solution
1W LEDs: ZXLD135x
3W LEDs: ZXLD136x
AEC-Q100 qualified
- **AP/AL880x range provides cost-effective solutions in standard packages**
SO-8/EP, MSOP-8/EP, SOT25, DFN3030-10
- **ZXLD137x multi-topology hysteretic LED drivers**
Supports high-performance buck, boost and buck-boost LED driver solutions

Medium Voltage Applications: General Illumination

LED Lamp Solution for Refrigerators



LED lamps are good solutions for commercial refrigerators because they provide uniform illumination, can operate from safe low voltages, and do not have start-up issues at low temperatures.

The AP8802H provides a small footprint solution for commercial refrigeration—requiring a minimum of four external components while driving 12 LEDs in series from a 48V rail. The device CTRL pin provides lamp dimming for advanced illumination options.

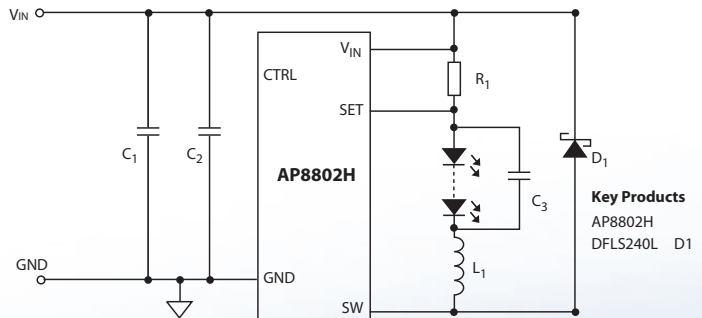

THE DIODES ADVANTAGE

AP8802H Benefits

The AP8802H provides a simple, cost-effective solution for commercial refrigeration applications

- **Operating voltage range up to 60V with $-40^{\circ}\text{C} \leq T_A \leq +125^{\circ}\text{C}$**
Up to fifteen LEDs can be connected in series; higher power can be delivered without reduction in lumens at low temperature
- **LED current can be up to 1A**
Drives both 1W and 3W LED systems
- **Up to 700kHz switching frequency**
Small, cost-effective inductor and capacitor can be used
- **5% initial average LED current accuracy**
Meets accuracy requirements of most lighting applications at a cost-effective price and improves inter-channel matching

Medium Voltage Applications: General Illumination

MR16 LED Lamp Solution



MR16 lamps require a high-reliability, small-footprint solution. These lamps frequently use different combinations of LEDs, ranging from three 1W LED to one 3W LED.

The AL8807W5 provides a cost-effective solution for driving multiple 1W and 3W LEDs in 12V_{AC} and 24V_{AC} powered lamps.

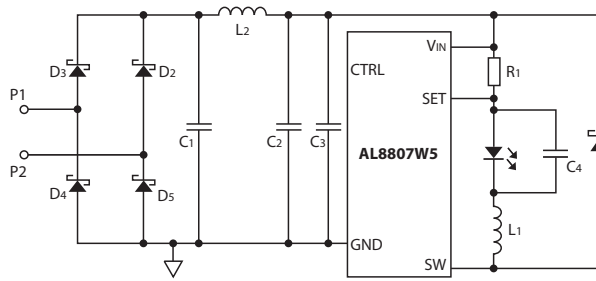

Key Products
AL8807W5
DFLS240L D1/2/3/4/5

THE DIODES ADVANTAGE

AL8807W5 Benefits

The AL8807W5 provides a simple, cost-effective solution for general illumination LED lamps

- **36V 1A LED drive capability**
Drives multiple 1W and 3W LED in series, providing cost-effective solutions for MR16
- **5% initial average LED current accuracy**
Cost-effective solution meets accuracy requirements of most lighting applications and improves inter-channel matching
- **High switching frequency up to 1MHz**
Small inductance value and size reduces solution size
- **Small footprint SOT25 uses only four external components**
High power density, small PCB footprint solution

High-Power MR16 Lamps



High-power MR16s are stretching the power density capability of the MR16 form factor and its ability to get heat out.

The AL8806 (1.5A) and AL8807MP (1.3A) with their 36V capability provide cost-effective solutions for high power MR16 lamps from 12V_{AC/DC} and 24V_{AC/DC} supplies.

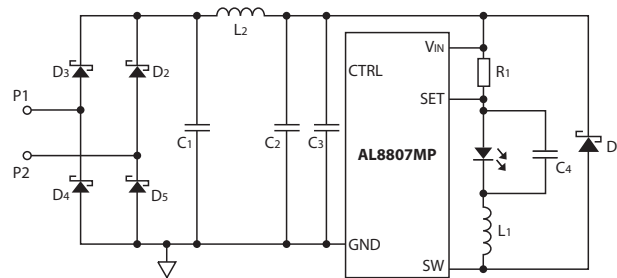

Key Products
AL8806
AL8807MP
DFLS240L D1
DFLS240L D1/2/3/4/5

THE DIODES ADVANTAGE

AL8807MP Benefits

- **36V 1.3A LED drive capability**
Drives up to eight SxP connected LED → cost effective solution for 12V_{AC/DC} systems
- **Small footprint MSOP-8EP package**
Delivers the power
- **5% initial average LED current accuracy**
Meets most lighting requirements
- **Simple PWM and Analog dimming on CTRL pin**
Provides flexible scheme to users with different dimming methods
- **High-switching frequency up to 1MHz**
Small inductance value reduces solution size

Medium Voltage Applications: General Illumination

LED Lamp Solution for Street Lights



Many high-power lamps utilize multiple serial channels of LEDs in parallel.

The ZXLD1366EN8 offers 2.5% accuracy, providing a simple solution for these high-power lamps by maintaining close matching between the parallel serial chains.

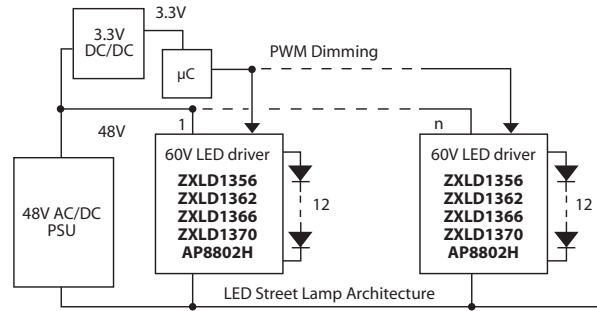

THE DIODES ADVANTAGE

ZXLD1366 Benefits

The ZXLD1366EN8 provides a simple, cost-effective solution for streetlight and high bay lighting applications

- Operating voltage range up to 60V and +125°C**
 Up to fifteen LEDs can be connected in series so that higher output power can be delivered without reduction in lumens at low temperature
- 2.5% initial average LED current accuracy**
 Meets accuracy requirement of most lighting applications and improves inter-channel matching
- Supports up to 1A LED current**
 Good match for 3W LED systems
- Low thermal impedance exposed pad SO-8EP package**
 Reduces junction temperature for increased long-term reliability

LED Lamp Solution for Wall Washers

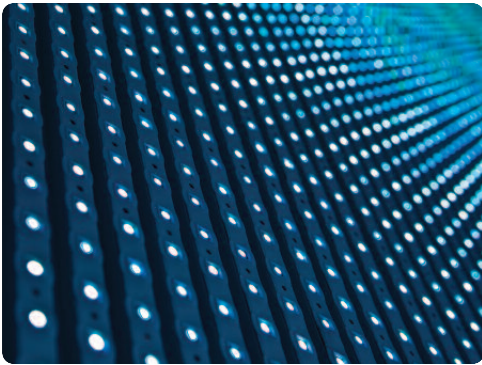

Drive long chains of low-current, high-brightness LEDs in series.

The ZXLD1370 LED driver-controller in boost mode offers simple, single-sense resistor brightness control with simple Analog and PWM dimming.

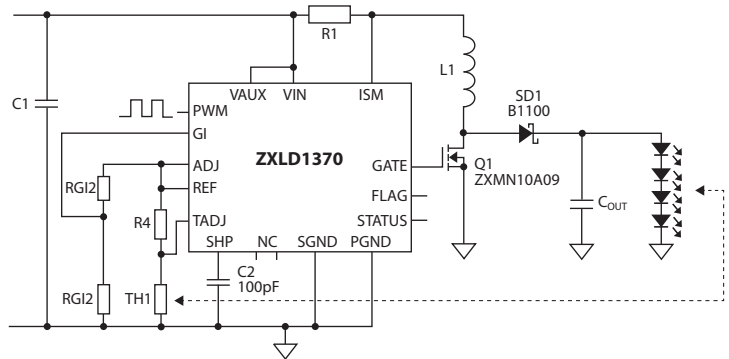

THE DIODES ADVANTAGE

ZXLD1370 Benefits

ZXLD1370 boost LED driver-controller provides a simple, cost-effective solution to wall washers

- 6V to 60V input voltage range**
 Operates from standard 12, 24 and 48V rails
- ZXLD1370 boost LED driver-controller**
 External FET determines LED chain length → increased versatility
- 2% LED current setting accuracy**
 Improved matching between channels
- Single-sense resistor brightness control in boost mode**
 Simple LED current control

Low Voltage DC-DC LED Drivers

Device	Topologies			Minimum Input Voltage	Maximum Input Voltage	Maximum Output Voltage	Maximum LED Current	Switching Frequency	Current Sense Voltage	Enable Pin	Efficiency	Operating Temperature Range	Quiescent Current	Available Packages
	Buck	Buck-Boost	Boost											
	V	V	V	A	kHz	mV	%	°C	mA					
ZXSC100	—	—	Y	0.93	3.5	Ext BJT	Ext BJT	200	730	N	82	-40 to +85	0.15	SO-8
ZXSC300	—	—	Y	0.8	8	Ext BJT	Ext BJT	—	19	N	94	-40 to +85	0.2	SOT25
ZXSC310	—	—	Y	0.8	8	Ext BJT	Ext BJT	—	19	Y	94	-40 to +85	0.2	SOT25
ZXSC380	—	—	Y	0.8	6	20	0.08	160	—	N	80	-40 to +85	—	SOT23
ZXSC400	—	—	Y	1.8	8	Ext BJT	Ext BJT	200	300	Y	85	-40 to +85	0.22	SOT26
ZXSC410	—	—	Y	1.8	8	Ext BJT	Ext BJT	200	300	Y	85	-40 to +85	0.22	SOT26
ZXSC420	—	—	Y	1.8	8	Ext BJT	Ext BJT	200	300	N	85	-40 to +85	0.22	SOT26
ZXSC440	—	—	Y	1.8	8	Ext BJT	Ext BJT	200	300	Y	85	-40 to +85	0.22	MSOP-8
ZXLD1320	Y	—	—	5	20	20	1.5	600	100	Y	85	-40 to +85	1.5	DFN4030-14
ZXLD1321	—	—	Y	1.2	12	20	1	600	100	Y	85	-40 to +85	1.5	DFN4030-14
ZXLD1322	—	Y	—	2.5	15	20	0.7	600	100	Y	85	-40 to +85	1.5	DFN4030-14
ZXLD381	—	—	Y	0.9	2.2	20	0.32	350	—	N	85	-40 to +85	—	SOT23
ZXLD383	—	—	Y	0.9	3.3	20	0.05	330	—	Y	85	-40 to +85	4	TSOT25

THE DIODES ADVANTAGE

Versatile low-voltage LED drivers



Product Benefits

Simple, low-voltage LED drivers capable of operating from as low as 0.8V

- Boost controllers**
 External transistor sets maximum LED current and chain voltage for increased versatility
- Boost drivers**
 Targeted for small footprint, low-current LED solutions
- 0.8V minimum input voltage**
 Operates over whole life of 1-cell, maximizing LED lamp run time
- ZXLD132x buck, boost and buck-boost LED drivers**
 Integrated 2A switch in a small footprint DFN4030 package

Low Voltage Applications: Portable Lighting

2-Cell Flashlight



Due to the cost-sensitive nature of flashlights, a simple low-cost solution with long running time is beneficial.

The ZXSC310 low-voltage boost controller provides such a solution. It operates with constant off-time and peak current switching topology. This reduces the average LED current automatically as the battery voltage is reduced, extending the flashlight run-time with only a small change in brightness.

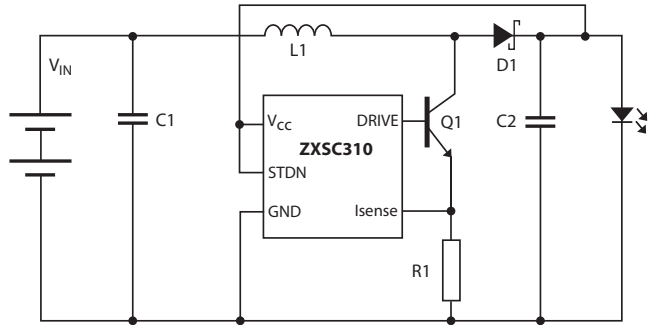

THE DIODES ADVANTAGE

ZXSC310 Benefits

Simple solutions for 1- and 2-cell flashlights increase operating life

- **0.9V minimum operating voltage**
Operates through whole life of 1- and 2-cell flashlights
- **LED current set by input voltage and current through R1**
LED current is reduced as the battery voltage decreases, increasing lamp run-time

Portable LED Projector

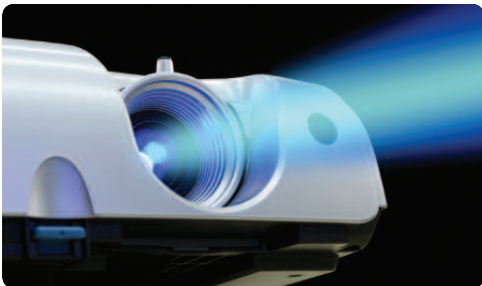

High-efficacy LEDs enable long operating life in portable projectors. Common-anode connected RGB LEDs are used to reduce wiring and ensure low thermal impedances for the LED. This requires the use of four high-efficiency, low-voltage LED drivers.

The ZXLD1320 LED driver can supply 1.5A in common anode configuration, offering a small footprint, high power-density solution to RGB common-anode portable projectors.

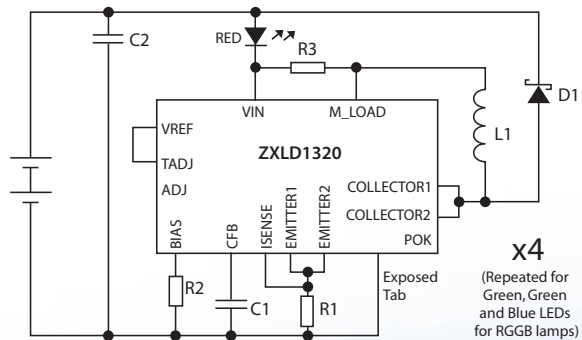

THE DIODES ADVANTAGE

ZXLD1320 Benefits

Simple, small-footprint solution for Li-Ion powered 4W LED lit portable LED projectors

- **5V to 20V input voltage range**
Operates from two to three Li-Ion cells
- **1.5A output current**
Drives 4W LEDs
- **High-efficiency buck LED driver**
Drives one 4W LED from one Li-Ion cell or two 4W LEDs from two Li-Ion cells
- **High power dissipation DFN4030-14 package**
Maintains high LED drive at higher ambient temperatures

Low Voltage Applications: Signage and Display

Single-Cell Emergency Lighting



Emergency lighting applications require long run times from rechargeable batteries.

The ZXLD1321 boost LED driver with its low operating voltage range allows it to operate from single and multi-cell lead-acid/NiCd/Li-Ion batteries. Its 1A drive capability supports 1W and 3W LED applications.

THE DIODES ADVANTAGE

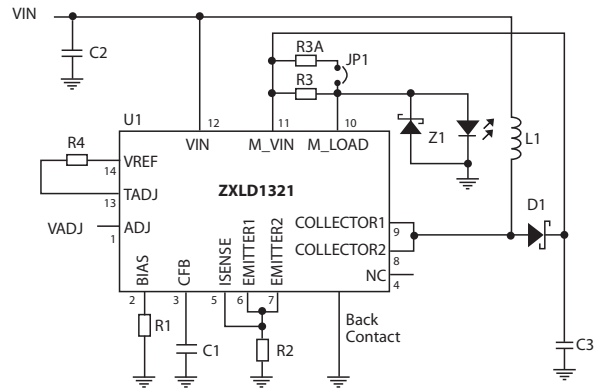

ZXLD1321 Benefits

Small-footprint solution for safety-critical applications

- **1.2V to 12V input voltage range**
Operates from a single rechargeable cell
- **1A load current**
Drives 3W LEDs
- **Boost topology**
Drives multiple 3W LEDs from one rechargeable cell
- **High power dissipation DFN4030-14 package**
Maintains high LED drive at higher ambient temperatures

Low Voltage Applications: General Illumination

Simple Solar Exterior Lights



Cost and run-time are important factors for solar powered exterior lamps. The ZXLD383 has been developed to meet these requirements.

Its 0.9V minimum operating voltage coupled with its 85% efficiency extends system operating life. The ZXLD383 offers a simple and elegant solution requiring only the LED, inductor and a solar cell, eliminating one diode from the system.

THE DIODES ADVANTAGE

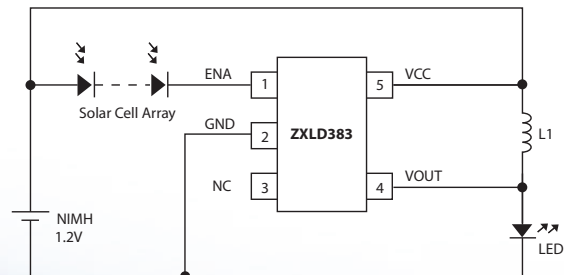

ZXLD383 Benefits

Simple boost and buck-boost LED driver solution requiring only one external component plus LEDs

- **Single-cell operation (0.9V minimum)**
- **85% efficiency**
Increased operating time at night
- **Simple flexible LED driving**
Requires only the inductor and LED
- **Low saturation voltage-switching transistor**
Improved efficiency
- **Dual function enable input**
Inhibits operation and prevents discharging the rechargeable solar cell during darkness

Linear LED Drivers

Part Number	Topology	Minimum Supply Voltage	Maximum Supply Voltage	Max V _{OUT}	LED Current Sense Voltage	Output Current	LED Current	Accuracy	Frequency	Efficiency	Dimming	Temperature Range	Available Packages
		V	V	V	V	mA	mA	%	kHz	%		°C	
AL8400	Linear Controller	2.2	18	18	0.2	15	external transistor	3	—	—	—	-40~to +125	SOT353
DLD101	Linear Driver	—	50	100	0.65	1000	1000	—	—	—	—	-40~to +85	DFN3030D-8
AL5801	Linear Driver	4.5	50	100	0.65	350	350	—	—	—	—	-40~to +85	SOT26
AL5802	Linear Driver	4.5	30	30	0.65	120	120	—	—	—	PWM	-40~to +125	SOT26
AL5811*	Linear Driver	3.5	60	60	0.5	75	75	3	—	—	—	-40~to +125	MSOP-8EP U-DFN3030-6
AL5812	Linear Driver	3.5	60	60	0.5	150	150	3	—	—	—	-40~to +125	MSOP-8EP U-DFN3030-6

*AL5811 due for release in 4Q 2012.



THE DIODES ADVANTAGE

Diodes Linear LED Driver Benefits

- **Small footprint packages**
High power density, small PCB footprint solution
- **AL8400—200mV sense voltage**
Reduces voltage overheads → more LED driven off any rail and reduces power dissipation
- **AL5811, AL5812, AL8400—3% initial average LED current accuracy**
Meets accuracy requirements at cost-effective price
- **Simple V_{BE} LED current reference voltage**
DLD101, AL5801 and AL5802 provide constant current LED drive, which automatically reduces LED current at high temperatures

Linear LED Lighting Applications

Signs

Letter signs using LEDs provide a more efficient, reliable and longer lifetime alternative to traditional neon letters.

The ability to drive long lines of low current LEDs at a low solution cost is essential

The AL8400 provides a versatile cost-effective solution to LED letter signs by allowing the LED driving transistor to be optimized for the current and voltage required.

THE DIODES ADVANTAGE

AL8400 Benefits

- **Small footprint SOT353 package**
High power density, small PCB footprint solution
- **200mV sense voltage**
Reduces voltage overheads → more LED driven off any rail and reduces power dissipation
- **3% initial average LED current accuracy**
Meets accuracy requirements at cost-effective price
- **Open-collector output drives transistor/MOSFET**
Allows best choice of pass transistor for LED drive
- **LED chain voltage and current set by external transistor/MOSFET**
Best pass transistor for LED chain voltage/current
LED chains longer than 18V can be driven with zener clamp on V_{CC} pin

Automotive LED Drivers

Part Number	AEC-Q100 Grade	Buck	Boost	Buck-Boost	Minimum Input Voltage	Maximum Input Voltage	Maximum Output Voltage	Maximum LED Current	LED Current Accuracy	Dimming		Maximum Switching Frequency	Efficiency	Operating Temperature Range	Quiescent Current	Standby Current	Available Packages
					V	V	V	A	%	PWM	Analog	kHz	%	°C	mA	µA	
AL8400SE	1	Y	—	—	2	18	18	Ext.	3	N	N	—	—	-40 to +125	—	—	SOT353
ZXLD1350ET5	2	Y	—	—	7	30	30	0.35	5	Y	Y	1000	95	-40 to +105	0.25	15	TSOT25
ZXLD1352ET5	2	Y	—	—	7	30	30	0.35	5	Y	Y	1000	97	-40 to +105	0.25	20	TSOT25
ZXLD1356ET5	1	Y	—	—	6	60	60	0.35	3	Y	Y	1000	97	-40 to +125	1.6	65	TSOT25
ZXLD1360ET5	1	Y	—	—	7	30	30	1	5	Y	Y	1000	95	-40 to +125	1.8	20	TSOT25
ZXLD1362ET5	1	Y	—	—	6	60	60	1	5	Y	Y	1000	95	-40 to +125	1.8	65	TSOT25
ZXLD1366EN8	1	Y	—	—	6	60	60	1	2.5	Y	Y	1000	95	-40 to +125	1.6	65	SO-8-EP
ZXLD1366ET5	1	Y	—	—	6	60	60	1	2.5	Y	Y	1000	95	-40 to +125	1.6	65	TSOT25
ZXLD1370EST16	1	Y	Y	Y	6.5	60	Ext. MOS	Ext. MOS	2	Y	Y	1000	95	-40 to +125	1.65	91	TSSOP-16EP
ZXLD1371EST16	1	Y	Y	Y	6.5	60	Ext. MOS	Ext. MOS	2	Y	Y	1000	95	-40 to +125	1.65	91	TSSOP-16EP
ZXLD1374EST20	1	Y	Y	Y	6.5	60	60	1.5	2	Y	Y	1000	95	-40 to +125	1.65	91	TSSOP-20EP
ZXLD1615	3	—	—	Y	2.7	5.5	28	NA	NA	N	N	1000	85	-40 to +85	0.06	1	TSOT25

Automotive Lighting Applications

Applications include: Daytime running lights, interior illumination, brake lights, fog lamps, door safety lights, auxiliary lighting, headlights and license plates.

Interior Lamps



LED lamps are increasingly being used due to their superior reliability and energy saving properties.

Typical LED currents range from 50mA to 150mA, so linear solutions are normally used. The lamp operates directly off the battery, requiring the driver to withstand load dump as well as meeting AEC-Q100 automotive quality requirements.

The AL8400 is qualified to AEC-Q100 grade 1. It is a controller which allows the external transistor to be optimized for the LED current/power dissipation providing a cost-effective solution. Its wide supply voltage range allows it to work below 9V and can withstand load dump conditions with the addition of a zener clamp diode.

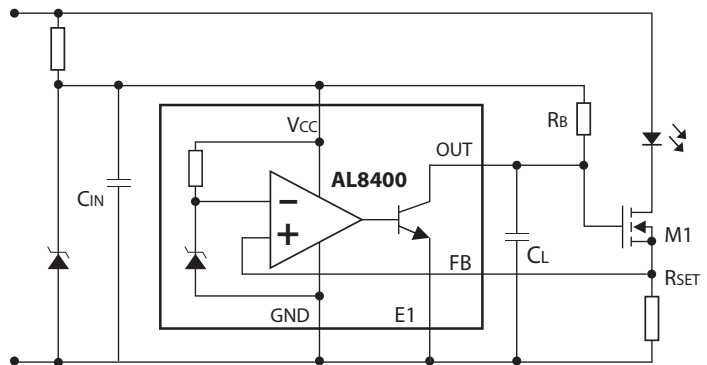

THE DIODES ADVANTAGE

AL8400 Benefits

- Qualified to AEC-Q100 grade 1
- Ambient temperature range up to +125°C
- Drives external transistor
Increases versatility → LED current and power dissipation set by external transistor
- Simple cost-effective solution

Automotive Lighting Applications

Door Lighting



Door safety lamps usually use just one high-brightness LED so a simple buck converter is typically used. The lamp operates directly off the battery, requiring the driver to withstand load dump as well as meeting AEC-Q100 automotive quality requirements.

The ZXL1362 is qualified to AEC-Q100 grade 1. Its 1A capability allows it to drive 3W LEDs while the device's 60V operating voltage withstands most load dump conditions.

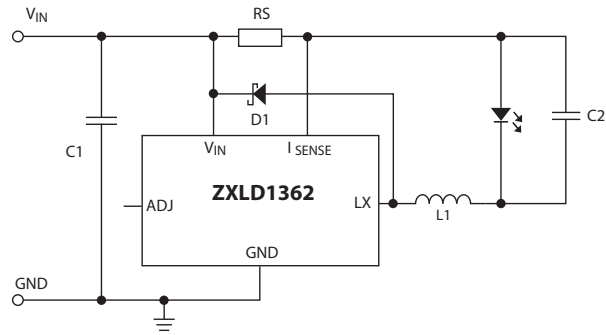

THE DIODES ADVANTAGE

ZXL1362ET5 Benefits

ZXL1362ET5 delivers a simple, small-footprint solution for automotive safety lighting

- **60V 1A LED drive capability**
Drives multiple 3W and 1W LEDs and withstands load dump
- **5% initial average LED current accuracy**
Meets accuracy requirements at a cost-effective price
- **AEC-Q100 grade 1 with 60V capability**
Suitable for wide range of automotive applications
- **Small footprint TSOT25 package requires only four external components**
High power density, small PCB footprint solution

Daytime Running Lights



Due to the variation in battery voltage and the number of LEDs used, buck-boost configurations are commonly used in daytime running lights.

The ZXL1371 LED driver used in buck-boost mode can deliver the accuracy, reliability and power drive needed for the large number of LEDs used in daytime running lights.

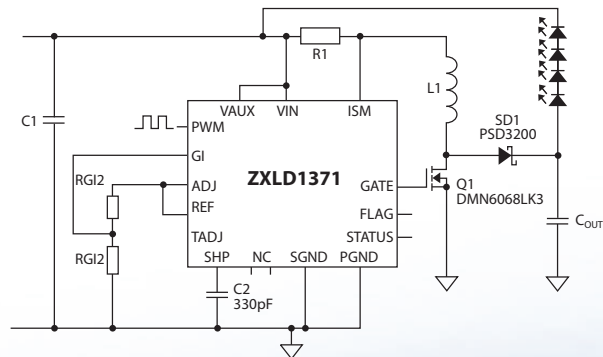

THE DIODES ADVANTAGE

ZXL1371 Benefits

The ZXL1371 provides a simple, high-reliability solution for driving LED daytime running lights

- **High accuracy LED control: 1% reference tolerance**
Better brightness control and matching between lamps
- **LED thermal management via external thermistor**
Improves reliability of LED lamps
- **Separate 1000:1 PWM dimming capability**
Improves dynamic range of dimming at lower light levels
- **5V minimum input voltage**
Supports DRL operation even during engine starting with new start/stop technology
- **Two-pin diagnostic feedback pins**
Reports back to the system the status of the LED driver and load, increasing overall system reliability

Backlighting ICs and Bias Generators

LED Backlight Drivers

Part Number	Type	Minimum Input Voltage	Maximum Input Voltage	Maximum Output Voltage	Number of Channels	Switching Frequency	Efficiency	Quiescent Current	Standby Current	SW R _{DS(on)}	Dimming	OVP	Soft Start	V _{FB}	Operating Temperature Range	Available Packages
		V	V	V		MHz	%	mA	μA	Ω				V	°C	
AP3154A	Charge pump	2.7	5.5	—	4	0.6/ 1.2/ 1.8	88	1.2	1	—	SDI	Y	Y	—	-40 to +85	DFN3030-12
AP3156	Charge pump	2.7	5.5	—	6	0.5/ 1.0/ 2.0	88	1.5	1	—	SDI	Y	Y	—	-40 to +85	QFN4040-16
AL3157	Charge pump	2.7	5.5	—	3 + 1	1.2	93	—	1	0.5	PWM	Y	Y	—	-40 to +85	U-DFN3030-12
AL3158	Charge pump	2.7	5.5	—	3 x 3 RGB	1.2	93	—	1	0.5	PWM	Y	Y	—	-40 to +85	QFN3030-20
AL3159	Charge pump	2.7	5.5	—	9	1.2	93	—	1	0.5	PWM	Y	Y	—	-40 to +85	QFN3030-20
AP5724	Boost	2.7	5.5	26	7	1.2	84	2	1	0.75	PWM	Y	Y	0.1	-40 to +85	DFN2020C-6 SOT26 TSOT26
AP5725	Boost	2.7	5.5	26	7	1.2	84	2	1	0.75	PWM	Y	Y	0.25	-40 to +85	DFN2020C-6 SOT26 TSOT26
AP5726	Boost	2.7	5.5	26	7	1.2	84	2	1	0.75	PWM	Y	Y	0.31	-40 to +85	DFN2020C-6 SOT26 TSOT26

THE DIODES ADVANTAGE



The Diodes Advantage

Simple, small-footprint solutions for small screen backlighting and biasing

- **High efficiency: up to 93% typical**
Longer battery life
- **Fast 1.2MHz switching frequency**
Smaller inductor and capacitor size
- **Inductive boost converters and multi-channel charge pumps**
High-efficiency, cost-effective solutions
- **Built-in soft-start, OVP, current limit and UVLO protection**
Extra protection for safe operation
- **Small footprint and low profile (as low as 0.4mm) packages**
Reduces PCB area and meets height constraints

LCD and OLED Bias Generators

Part Number	Type	Minimum Input Voltage	Maximum Input Voltage	Maximum Output Voltage	Number of LED	Frequency	Efficiency	Quiescent Current	Standby Current	SW R _{DS(on)}	Dimming	OVP	Soft Start	V _{FB}	Operating Temperature Range	Available Packages
		V	V	V		MHz	%	μA	μA	Ω				V	°C	
AP5727	Boost	2.7	5.5	30	—	1.2	84	500	0.1	0.95	N	N	Y	1.25	-40 to +85	SOT25
ZXLD1615	Boost	2.7	5.5	28	—	1	85	60	1	1.75	N	N	N	1.25	-40 to +85	TSOT25

Small Screen Display Applications

5" PND Screen



Larger portable navigation device (PND) screens require more LEDs to maintain display quality in variable background light conditions. The AL3159, with its current matching accuracy, is well-suited for this requirement.

The high-efficiency linear and charge-pump functionality extends the device operating life when powered from the PND's internal Li-Ion battery.

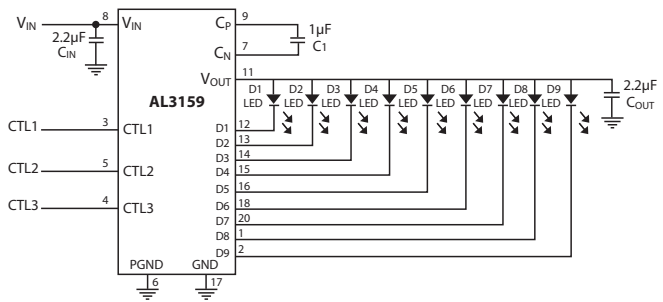

AL3159 Benefits

The AL3159 provides a simple, cost-effective solution for small LED backlit LCD screens

- **Up to 93% max power efficiency**
Increases battery life—improving talk time
- **1% current matching accuracy between channels**
Improves consistency of backlight for enhanced screen image
- **Drives up to nine channels of LEDs**
Versatile solution for portable consumer electronics equipment
- **Versatile 3-wire logic decoding of LED current control**
Simplifies driving and illumination of small LCD screens
- **Thin QFN3030-20 packages requiring only three small low-profile capacitors**
Small, thin solution reduces size of portable LED backlighting

THE DIODES ADVANTAGE

3" Mobile Phone Screen



Large screen (>2.8") mobile phones frequently use six LED to ensure uniform brightness across the screen.

AP5724/5/6 boost LED drivers provide a high-efficiency solution for this application. The series connection of the LED ensures uniform brightness from the LEDs. The TSOT23-6 packaged versions offer industry-standard pinouts and are thinner than 1mm.

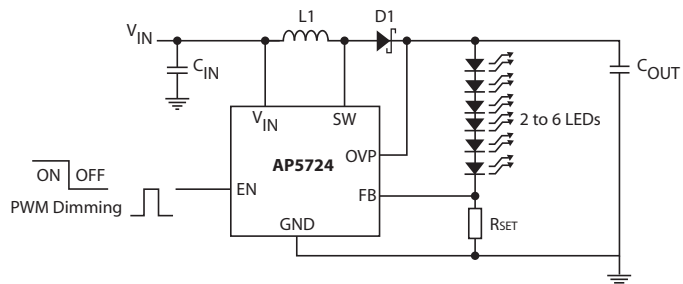

AP5724/5/6 Benefits

Simple, small-footprint solutions for small screen backlighting

- **High efficiency: 84% typical**
Longer battery life
- **Fast 1.2MHz switching frequency**
Smaller inductor and capacitor size
- **Built-in OVP, current limit and UVLO protection**
Extra protection for safe operation
- **Three choices of V_{FB} (0.1, 0.25 and 0.31V)**
Offers extra design flexibility
- **Low profile (<1mm) packages: TSOT23-6 and DFN2020C-6 (0.6mm)**
Meets height constraints of modern, thin, portable equipment

THE DIODES ADVANTAGE

LED Driver Evaluation Boards

Device	Board Number	Description of Assembly	Package used
AL3157	AL3157F-EVM Rev.1	3-channel backlight + 1-channel flashlight white LED charge pump LED driver	U-DFN3030-12
AL3158	AL3158FSG-EV-RGB	3 x 3-channel RGB backlight LED charge pump LED driver	QFN3030-20
AL3159	AL3159FSG-EVM Rev.1	9-channel backlight white LED charge pump LED driver	QFN3030-20
AL5802	AL5802EV1	30V, adjustable current sink linear LED driver, preset for 20, 50 or 100mA LED current	SOT26
AL8400	AL8400EV1	18V simple LED driver-controller evaluation board	SOT353
AL8805	AL8805EV1	36V, 1A buck LED driver, 660mA, control input, no onboard LEDs	SOT25
AL8805	AL8805EV2	MR16 replacement, external 3W LED, $V_{IN} = 12V_{AC}$ 50/60Hz or $12V_{DC}$ 660mA	SOT25
AL8806	AL8806EV4	36V, 1.5A buck LED driver, 1.5A LED current, control input, no onboard LEDs	MSOP-8EP
AL8806	AL8806EV6	MR16 replacement, external LED, $V_{IN} = 12V_{AC}$ 50/60Hz or $12V_{DC}$ 1.1A LED current	MSOP-8EP
AL8807	AL8807EV2	MR16 replacement, external LED, $V_{IN} = 12V_{AC}$ 50/60Hz or $12V_{DC}$ 660mA LED current	SOT25
AL8807	AL8807EV3	36V, 1.3A buck, LED driver, 1.3A LED current control input, no onboard LEDs	MSOP-8EP
AL8807	AL8807EV4	MR16 replacement, external LED, $V_{IN} = 12V_{AC}$ 50/60Hz or $12V_{DC}$ 1.1A LED current	MSOP-8EP
AL9910	AL9910EV4	Non-isolated universal AC supply driving 14 to 18 LEDs at 180mA (PLED ~ 7 to 10W)	SO-8
AL9910	AL9910EV5	Non-isolated universal AC supply driving 14 to 18 LEDs at 240mA (PLED ~ 10 to 13W)	SO-8
AL9910	AL9910EV6	110V _{AC} isolated supply LED driver	SO-8EP
AL9910A	AL9910EV7	Triac dimmable, E27/A19, 110V _{AC} evaluation board	SO-8
AL9910	AL9910EV8	Non-dimmable, E27/A19, 110V _{AC} evaluation board	SO-8
AL9910A	AL9910EV9	Triac dimmable, E27/A19, 230V _{AC} evaluation board	SO-8
AL9910	AL9910EV12	Non-dimmable, E14/B10, 85 to 230V _{AC} evaluation board	SO-8EP
AP3156	AP3156FVG-EV	6-channel backlight LED driver, charge pump, $V_{IN} = 2.7V$ to 5.5V	DFN4040-16
AP5724	AP5724-EV	Boost backlight LED driver 1.2MHz, 2.7V to 5.5V input, 100mV feedback	SOT26
AP5727	AP5727-EV	Boost LCD and OLED bias generator 1.2MHz, 2.7V to 5.5V input, 1.25V feedback	SOT25
AP8800	AP8800EV2	Buck LED driver, $V_{IN} = 8V$ to 28V, 300mA, control input, no onboard LEDs	MSOP-8
AP8801	AP8801EV2	Buck LED driver, $V_{IN} = 8V$ to 48V, 460mA, control input, no onboard LEDs	MSOP-8
AP8802	AP8802EV2	Buck LED driver, $V_{IN} = 8V$ to 48V, 1A, control input, no onboard LEDs	SO-8
AP8802H	AP8802HEV2	Buck LED driver, $V_{IN} = 8V$ to 60V, 1A, control input, no onboard LEDs	SO-8EP
DLD101	DLD101EV1	High-voltage linear LED driver	DFN3030D-8
ZXLD1320	ZXLD1320EV1	Buck LED driver, 500kHz PFM, $V_{IN} = 5V$ to 18V, 1.5A output, + ext. thermistor	DFN4030-14
ZXLD1321	ZXLD1321EV1	Boost LED driver, 550kHz PFM, $V_{IN} = 1.2V$ to 12V, 1A output, + ext. thermistor	DFN4030-14
ZXLD1322	ZXLD1322EV1	Buck-boost LED driver, 550kHz PFM, $V_{IN} = 2.5V$ to 15V, 0.7A output, + ext. thermistor	DFN4030-14
ZXLD1350	ZXLD1350EV3	Buck LED driver, $V_{IN} = 12V$ to 30V, 3 Cree LEDs at 300mA, + adjust input	TSOT25
ZXLD1350	ZXLD1350EV4	Buck LED Driver, $V_{IN} = 12V$ to 30V, 3 Osram LEDs at 300mA, + adjust input	TSOT25
ZXLD1350	ZXLD1350EV7	Buck LED Driver, $V_{IN} = 12V$ to 30V, 3 Lumiled LEDs at 300mA + adjust input	TSOT25
ZXLD1356	ZXLD1356EV1	LED driver, buck, $V_{IN} = 7V$ to 60V, external LED, 0.55A output FR4 PCB TSOT	TSOT25
ZXLD1360	ZXLD1360EV13	MR16 replacement, external 3W LED, $V_{IN} = 12V_{AC}$ or $12V_{DC}$ nominal, 660mA	TSOT25
ZXLD1362	ZXLD1362EV3	LED driver, buck, $V_{IN} = 7V$ to 60V, external LED, 700mA output aluminium PCB	TSOT25
ZXLD1366	ZXLD1366EV3	LED driver, buck, $V_{IN} = 6V$ to 47V, external LED, 1A output FR4 PCB	SO-8EP
ZXLD1370	ZXLD1370EV2	Buck-boost and boost LED driver-controller, $V_{IN} = 6.5V$ to 60V, flag, status outputs	TSSOP-16EP
ZXLD1370	ZXLD1370EV3	Buck LED driver-controller, $V_{IN} = 6.5V$ to 60V, high current, FR4 PCB flag, status outputs	TSSOP-16EP
ZXLD1371	ZXLD1371EV4	Buck LED driver-controller, $V_{IN} = 5.0V$ to 60V, FR4 PCB flag, status outputs	TSSOP-16EP
ZXLD1371	ZXLD1371EV5	Buck-boost LED driver-controller, $V_{IN} = 5.0V$ to 60V, flag, status outputs	TSSOP-16EP
ZXLD1371	ZXLD1371EV6	Boost LED driver-controller, $V_{IN} = 5.0V$ to 60V, flag, status outputs	TSSOP-16EP
ZXLD1374	ZXLD1374EV1	Buck LED driver, $V_{IN} = 6V$ to 60V, 1.5A output FR4 PCB, flag, status outputs	TSSOP-20EP
ZXLD1374	ZXLD1374EV2	Buck-boost and boost LED driver, $V_{IN} = 6V$ to 60V, 350mA output. flag, status outputs	TSSOP-20EP
ZXLD1615	ZXLD1615EV1	Boost LCD and OLED Bias Generator, $V_{IN} = 2.5V$ to 5.5V, $V_{OUT} = 12V$, 80mA	TSOT25
ZXLD381	ZXLD381EV1	Single or multi-cell boost LED driver, $V_{IN} = 0.9V_{MIN}$	SOT23
ZXLD383	ZXLD383EV1	Boost LED driver for garden lights $V_{IN} = 0.9V_{MIN}$ solar cell connection	SOT25
ZXSC310	ZXSC310EV(1)	Boost LED driver, $V_{IN} = 3.3V$ to 5V, 4 white LEDs	SOT25
ZXSC380	ZXSC380EV1	Boost LED driver, $V_{IN} = 1V$ to 3V (single cell), white LED at 18mA, rectangular board	SOT23
ZXSC400	ZXSC400EV1	LED driver, boost, $V_{IN} = 2.5V$ to 4.2V, 3 LEDs Nichia NSCW215, at 20mA	SOT26

For further information and to get an Evaluation Board visit www.diodes.com or contact a Diodes' Sales Office.

Drivers for Industry-Standard LEDs

Diodes Products		LEDs		Cree			Everlight			LumiLEDs			Osram			Seoul Semiconductor			Sharp																														
				XLamp MT-G	XLamp XP-E	XLamp XR-E	XLamp XR-C	XLamp XP-C	XLamp MPL-EZW	HV Series	Yi	Shuen and Shuo	A09K	LUXEON Aitilon	LUXEON Rebel	LUXEON S	LUXEON A	LUXEON C	LUXEON H	Diamond Dragon	Platinum Dragon	OSTAR	OSLON	Golden Dragon Plus	TopLED	Top View	Z2	Z5	P3-II	Z7	P9	SAE	D.Dome	Mega Zenigata	Mini Zenigata	Zenigata													
				6V	36V	3.2V	3.5V	3.6V	3.4V	25V	50V	100V	7.8V	4.05V	3.5V	3.5V	7.5/14.5V	3V	27V	2.88V	2.95V	50V	3.4V	3.45V	3.2V	3.2V	3.2V	3.4V	3.2V	10V	3.3V	3.5V	3.5V	3.3V	3.65V	3V	3.05V	37V	19.6V	13.1V	10.2V								
Nominal LED current (mA)		1100	185	700	700	500	350	150	20	20	700	700	350	150	1000	700	700	350	30	1400	700	350	350	350	30	60/100	350	350	350	1400	150	20	220	700	400	480	520	360	640										
LED Driver	Max Current																																																
AL8805	1000			Y	Y	Y	Y				Y	Y	Y	Y			Y	Y			Y						Y	Y	Y	Y	Y			Y		Y	Y	Y	Y	Y									
AP8806	1500	Y									Y	Y	Y	Y						Y	Y						Y	Y	Y	Y	Y	Y					Y	Y	Y	Y	Y	Y							
AP8807	1000			Y	Y	Y	Y				Y	Y	Y	Y							Y						Y	Y	Y	Y	Y	Y					Y	Y	Y	Y	Y	Y	Y						
AP9910	Ext MOS	Y	Y	Y	Y	Y	Y	Y	Y						Y	Y											Y	Y	Y	Y	Y	Y	Y			Y													
AP8800A	370					Y						Y	Y														Y	Y	Y	Y	Y	Y	Y	Y					Y										
AP8801	500		Y			Y	Y					Y	Y					Y									Y	Y	Y	Y	Y	Y					Y	Y	Y	Y	Y	Y	Y						
AP8802	1000		Y	Y	Y	Y	Y				Y	Y	Y														Y	Y	Y	Y	Y	Y	Y			Y	Y	Y	Y	Y	Y	Y	Y	Y					
AP8802H	1000		Y	Y	Y	Y	Y				Y	Y	Y						Y								Y	Y	Y	Y	Y	Y	Y			Y	Y	Y	Y	Y	Y	Y	Y	Y	Y				
AP8803	1000			Y	Y	Y	Y				Y	Y	Y														Y	Y	Y	Y	Y	Y	Y			Y		Y	Y	Y	Y	Y	Y	Y	Y				
DLD101	1000		Y												Y												Y	Y	Y	Y	Y	Y			Y	Y													
ZXLD381								Y	Y																		Y	Y							Y														
ZXLD383								Y																			Y	Y																					
ZXLD1320	1500	Y		Y	Y	Y	Y				Y	Y	Y							Y	Y						Y	Y	Y	Y	Y	Y							Y	Y	Y	Y	Y	Y	Y	Y			
ZXLD1321	700			Y	Y	Y	Y				Y	Y	Y														Y	Y	Y	Y	Y	Y							Y	Y	Y	Y	Y	Y	Y	Y			
ZXLD1322	700			Y	Y	Y	Y				Y	Y	Y														Y	Y	Y	Y	Y	Y																	
ZXLD1350	380					Y					Y	Y							Y								Y	Y	Y	Y	Y	Y				Y													
ZXLD1352	380					Y					Y	Y															Y	Y	Y	Y	Y	Y																	
ZXLD1356	550					Y					Y	Y															Y	Y	Y	Y	Y	Y							Y	Y									
ZXLD1360	1000		Y			Y	Y				Y	Y	Y	Y	Y	Y											Y	Y	Y	Y	Y	Y				Y													
ZXLD1362	1000			Y	Y	Y	Y				Y	Y	Y	Y	Y	Y	Y										Y	Y	Y	Y	Y	Y					Y	Y	Y	Y	Y	Y	Y	Y	Y	Y	Y	Y	
ZXLD1366	1000		Y	Y	Y	Y	Y				Y	Y	Y	Y	Y	Y	Y										Y	Y	Y	Y	Y	Y							Y	Y	Y	Y	Y	Y	Y	Y	Y	Y	
ZXLD1370	Ext MOS	Y	Y	Y	Y	Y	Y				Y	Y	Y	Y	Y	Y	Y										Y	Y	Y	Y	Y	Y	Y	Y					Y	Y	Y	Y	Y	Y	Y	Y	Y	Y	
ZXLD1371	Ext MOS	Y	Y	Y	Y	Y	Y				Y	Y	Y	Y	Y	Y	Y										Y	Y	Y	Y	Y	Y	Y	Y					Y	Y	Y	Y	Y	Y	Y	Y	Y	Y	
ZXLD1374	1500	Y	Y	Y	Y	Y	Y				Y	Y	Y	Y	Y	Y	Y										Y	Y	Y	Y	Y	Y	Y																
ZXSC310	Ext BJT							Y			Y	Y	Y														Y	Y	Y	Y	Y	Y							Y										
ZXSC380	80							Y																			Y	Y																					
ZXSC400	Ext BJT					Y	Y	Y							Y	Y											Y	Y	Y	Y	Y	Y																	

CORPORATE HEADQUARTERS AND AMERICAS SALES OFFICE

4949 Hedgcoxe Road
Suite 200
Plano, Texas 75024
972-987-3900 USA
E-mail: inquiries@diodes.com

EUROPE SALES OFFICE

Kustermann-Park
Balanstrasse 59, 8th Floor
D-81541 Munchen, Germany
Tel: (+49) 89 45 49 49 0
E-mail: inquiries-europe@diodes.com

ASIA SALES OFFICES

Email: inquiries-asia@diodes.com

DIODES-TAIWAN

7F, No. 50, Min-Chuan Road
Hsin-Tien District,
New Taipei City 23141, Taiwan, R.O.C.
Tel: 011-886-2-8914-6000

SHANGHAI OFFICE

Room 3001-3002,
International Corporate City, No. 3000
Zhongshan North Road,
Shanghai 200063, China
Tel: 86 21-5241-4882

SHENZHEN OFFICE

Room A1103-04, ANLIAN Plaza, #4018
Jintian Road, Futian CBD,
Shenzhen, China
Tel: 86 755-88284988

DIODES-KOREA

1601 ho, ParkView Tower
Jeongja 1 dong, Bundang-gu
Seongnam-si, Gyeonggi-do,
Korea 463-811
Tel: 82-31-786-0434

For information or literature,
please visit www.diodes.com/contacts

