



VISHAY INTERTECHNOLOGY, INC.

# INTERACTIVE

## data book

---

### PRECISION POTENTIOMETERS, INDUSTRIAL SENSORS

VISHAY SFERNICE

---

VSE-DB0100-0802

#### Notes:

1. To navigate:
  - a) Click on the Vishay logo on any datasheet to go to the Contents page for that section. Click on the Vishay logo on any Contents page to go to the main Table of Contents page.
  - b) Click on the products within the Table of Contents to go directly to the datasheet.
  - c) Use the scroll or page up/page down functions.
  - d) Use the Adobe® Acrobat® page function in the browser bar.
2. To search the text of the catalog use the Adobe® Acrobat® search function.



One of the World's Largest Manufacturers of  
**Discrete Semiconductors and Passive Components**



VISHAY INTERTECHNOLOGY, INC.



## PRECISION POTENTIOMETERS, INDUSTRIAL SENSORS

VISHAY SFERNICE

Single Turn Rotational Conductive Plastic Film Technology

Linear Motion Transducers

Multiturn Wirewound Precision Potentiometers

Counting Turns Dials

Single Turn Wirewound Precision Potentiometers

Position Sensors in Hall Effect Technology

## SEMICONDUCTORS

### RECTIFIERS

- Schottky (single, dual)
- Standard, Fast, and Ultra-Fast Recovery (single, dual)
- Bridge
- Superrectifier®
- Sinterglass Avalanche Diodes

### HIGH-POWER DIODES AND THYRISTORS

- High-Power Fast-Recovery Diodes
- Phase-Control Thyristors
- Fast Thyristors

### SMALL-SIGNAL DIODES

- Schottky and Switching (single, dual)
- Tuner/Capacitance (single, dual)
- Bandswitching
- PIN

### ZENER AND SUPPRESSOR DIODES

- Zener (single, dual)
- TVS (TRANSZORB®, Automotive, ESD, Arrays)

### FETs

- Low-Voltage TrenchFET® Power MOSFETs
- High-Voltage TrenchFET® Power MOSFETs
- High-Voltage Planar MOSFETs
- JFETs

### RF TRANSISTORS

- Bipolar Transistors (AF and RF)
- Dual Gate MOSFETs
- MOSMICs®

### OPTOELECTRONICS

- IR Emitters and Detectors, and IR Receiver Modules
- Optocouplers and Solid-State Relays
- Optical Sensors
- LEDs and 7-Segment Displays
- Infrared Data Transceiver Modules
- Custom Products

### ICs

- Power ICs
- Analog Switches
- RF Transceivers and Receiver Modules
- ICs for Optoelectronics

### MODULES AND ASSEMBLIES

- Automotive Modules and Assemblies
- Power Modules (contain power diodes, thyristors, MOSFETs, IGBTs)
- DC/DC Converters

## PASSIVE COMPONENTS

### RESISTIVE PRODUCTS

- Foil Resistors
- Film Resistors
  - Metal Film Resistors
  - Thin Film Resistors
  - Thick Film Resistors
  - Metal Oxide Film Resistors
  - Carbon Film Resistors
- Wirewound Resistors
- Power Metal Strip® Resistors
- Chip Fuses
- Variable Resistors
  - Cermet Variable Resistors
  - Wirewound Variable Resistors
  - Conductive Plastic Variable Resistors
- Networks/Arrays
- Non-Linear Resistors
  - NTC Thermistors
  - PTC Thermistors
  - Varistors

### MAGNETICS

- Inductors
- Transformers

### CAPACITORS

- Tantalum Capacitors
  - Molded Chip Tantalum Capacitors
  - Coated Chip Tantalum Capacitors
  - Solid Through-Hole Tantalum Capacitors
  - Wet Tantalum Capacitors
- Ceramic Capacitors
  - Multilayer Chip Capacitors
  - Disc Capacitors
- Film Capacitors
- Power Capacitors
- Heavy-Current Capacitors
- Aluminum Capacitors
- Silicon RF Capacitors

### STRAIN GAGE TRANSDUCERS AND STRESS ANALYSIS SYSTEMS

- PhotoStress®
- Strain Gages
- Load Cells
- Force Transducers
- Instruments
- Weighing Systems
- Specialized Strain Gage Systems

# Precision Potentiometers, Industrial Sensors

**Vishay Spectrol, Inc**

4051 Greystone Drive  
Ontario  
California 91761  
U.S.A.

**Phone:** +1 909 923 3313

**Fax:** +1 909 923 6765

**[www.vishay.com](http://www.vishay.com)**

**Vishay S.A.**

199, bd de la Madeleine  
B.P. 1159  
06003 Nice Cedex 1  
France

**Phone:** +33 4 93 37 27 27

**Fax:** +33 4 93 37 27 26

**[www.vishay.com](http://www.vishay.com)**

### **NOTICE**

Specifications of the products displayed herein are subject to change without notice. Vishay Intertechnology, Inc., or anyone on its behalf, assumes no responsibility or liability for any errors or inaccuracies.

Information contained herein is intended to provide a product description only. No license, express or implied, by estoppel or otherwise, to any intellectual property rights is granted by this document. Except as provided in Vishay's terms and conditions of sale for such products, Vishay assumes no liability whatsoever, and disclaims any express or implied warranty, relating to sale and/or use of Vishay products including liability or warranties relating to fitness for a particular purpose, merchantability, or infringement of any patent, copyright, or other intellectual property right.

The products shown herein are not designed for use in medical, life-saving, or life-sustaining applications. Customers using or selling these products for use in such applications do so at their own risk and agree to fully indemnify Vishay for any damages resulting from such improper use or sale.



# Precision Potentiometers, Industrial Sensors

General Information .....	4
Application Notes .....	8
General Performances .....	9

## PLASTIC FILM TECHNOLOGY

### ROTATIONAL

#### Industrial Models

Model 138	1 5/16" (33.3 mm) Industrial Single Turn, Bushing Mount, Conductive Plastic .....	12
Model 139	1 5/16" (33.3 mm) Industrial Single Turn Cermet Bushing Mount Model .....	14
Model 157	7/8" (22.2 mm) Precision Industrial Potentiometer Bushing and Servo Mount Versions, Conductive Plastic .....	16
Model 159	7/8" (22.2 mm) Single Turn Cermet Precision Potentiometer .....	18
Model 357	7/8" (22.2 mm) Conductive Plastic Potentiometer, Bushing Mount Type .....	21
Model 657	Industrial Rotary Position Sensor, Bushing Mount Type, Conductive Plastic .....	23
Series ECO	Precision Rotative Transducers, Conductive Plastic, Economic Series (ECO) .....	25
Series ECS	Precision Rotative Transducers, Conductive Plastic, Economic Series (ECS) .....	28
Series KIT RMF	Conductive Plastic Rotative Transducer Elements (KIT) .....	30

#### Professional Models

Model 128	1 1/16" (27 mm) Single Turn Conductive Plastic Precision Potentiometer .....	32
Model 208	1 3/4" (44.5 mm) Single Turn Conductive Plastic Precision Potentiometer .....	35
Model 308	2" (50.8 mm) Single Turn Conductive Plastic Precision Potentiometer .....	38
Model 708	7/8" (22.2 mm) Single Turn Conductive Plastic Precision Potentiometer .....	41
Series ROT/BF	Precision Rotative Transducers, Conductive Plastic, Bushing Mounting .....	44
Series ROT/SF	Precision Rotative Transducers, Conductive Plastic, Servo Mounting .....	46
Series 116 BFZ-SFZ	Precision Rotative Transducers 360° Special Laws: Sine/Cosine .....	48

### LINEAR

#### Industrial Models

Series REC 10 LA	Precision Linear Transducers, Designed for Mounting in Hydraulic or Pneumatic Cylinder, Conductive Plastic (Sealed Series/Ø 10 mm) .....	52
Series REC 10 LH	Precision Linear Transducers, Designed for Mounting in Hydraulic or Pneumatic Cylinder, Conductive Plastic Element (Unsealed Series/Ø 10 mm) .....	54
Series REC 16 LA	Precision Linear Transducers, Designed for Mounting in Hydraulic or Pneumatic Cylinder, Conductive Plastic Element (Sealed Series/Ø 16 mm) .....	56
Series REC 16 LH	Precision Linear Transducers, Designed for Mounting in Hydraulic or Pneumatic Cylinder, Conductive Plastic Element (Unsealed Series/Ø 16 mm) .....	59
Series REC 110 L	Precision Linear Transducers, Conductive Plastic, up to 450 mm .....	61
Series REC 115 L	Precision Linear Transducers, Conductive Plastic, up to 1000 mm .....	65
Series REC 139 L	Precision Linear Transducers, Conductive Plastic, up to 3000 mm .....	67
Series KIT LMF	Conductive Plastic Motion Transducer Elements (KIT), up to 1000 mm .....	69

#### Professional Models

Series REC 34 L	Precision Linear Transducers, Conductive Plastic, up to 450 mm .....	71
Series REC 38 L	Precision Linear Transducers, Conductive Plastic, up to 150 mm .....	74
Series REC 50 L	Precision Linear Transducers, Conductive Plastic, up to 300 mm .....	76



## WIREWOUND TECHNOLOGY

### SINGLE TURN MODELS

Model 100	1 5/16" (33.3 mm) Single Turn Wirewound Precision Potentiometer .....	80
Model 122	1 1/16" (27 mm) Single Turn Wirewound Precision Potentiometer .....	83
Model 132	1 5/16" (33.3 mm) Low Cost Industrial Single Turn Wirewound, Bushing Mount Type ...	86
Model 140	1/2" (12.7 mm) Single - Turn Wirewound Bushing Mount Type Precision Potentiometer	88
Model 142	1/2" (12.7 mm) Single - Turn Wirewound Servo Mount Type Precision Potentiometer ..	90
Model 152	7/8" (22.2 mm) Single Turn Wirewound, Precision Potentiometer .....	92
Model 172	1 7/16" (36.5 mm) Single Turn Wirewound Precision Potentiometer .....	95
Model 182	3/4" (19 mm) Single Turn Wirewound Servo Mount Precision Potentiometer .....	98
Model 202	1 3/4" (44.5 mm) Single Turn Wirewound Precision Potentiometer .....	100
Model 302	2" (50.8 mm) Single Turn Wirewound Precision Potentiometer .....	103
Model 402	3" (76.2 mm) Single Turn Wirewound Precision Potentiometer .....	106
Model 452	3" (76.2 mm) Single Turn Wirewound Servo Mount, Precision Potentiometer, Sine/Cosine laws .....	109
Model 702	7/8" (22.2 mm) Single Turn Wirewound Precision Potentiometer .....	112

### MULTITURN MODELS

Model 162	1/2" (12.7 mm) Ten Turn Wirewound Bushing Mount Precision Potentiometer .....	116
Model 164	1/2" (12.7 mm) Ten Turn Wirewound Servo Mount Precision Potentiometer .....	118
Model 502	7/8" (22.2 mm) Ten-Turn Wirewound Upper Grade Precision Potentiometer .....	120
Model 533/534/535	7/8" (22.2 mm) Multiturn Wirewound 533: 3 Turns/534: 10 Turns/535: 5 Turns .....	123
Model 536	7/8" (22.2 mm) Ten Turn Wirewound Precision Potentiometer with a Plastic Shaft .....	126
Model 552	7/8" (22.2 mm) Three Turn Wirewound Upper Grade Precision Potentiometer .....	129
Model 802	1 13/16" (46 mm) Ten Turn Wirewound Upper Grade Precision Potentiometer .....	132
Model 830	1 13/16" (46 mm) Three Turn Wirewound Bushing Mount .....	135
Model 852	1 13/16" (46 mm) Three Turn Wirewound Upper Grade Precision Potentiometer .....	138
Model 860	1 13/16" (46 mm) Ten Turn Wirewound, Bushing Mount .....	141

### SPECIAL DESIGN

Model 601-1045	Full 360° Smart Position Sensor .....	146
Model 970-1036	Industrial Sensor for Harsh Environment (Throttle Position/Through Hole) .....	148
Model 971	Throttle Position Sensor with Integrated Spring Return System .....	150

### OTHER TECHNOLOGIES

#### ENCODERS

Model 120E	Incremental Optical Encoder Contactless Technology (128 Pulses per Turn) .....	154
Model DE2	Incremental Resistive Encoder (32 to 128 Pulses per Turn) .....	156

#### HALL EFFECT SENSORS

Model 351 HE	Single Turn Bushing Mount Hall Effect Sensor in Size 09 (22.2 mm) Comoulded Plastic Housing .....	160
Model 601 HE	Full 360° Smart Sensor (Hall Effect Technology) .....	164
Model 631 HE	Single Turn Bushing Mount Hall Effect Sensor in Size 09 (22.2 mm) Aluminum Housing	166



**ACCESSORIES**

**DIALS**

Model 11	25.4 mm Diameter Eleven Turn Dial .....	172
Model 15	Rectangular 10 Turn Dial (3 Digit), (4 Digit) 100 Turn.....	173
Model 18	Model 18 (PR2) 22.2 mm Diameter, 15 Turn Dial .....	174
Model 21	46.02 mm Diameter 15 Turn Dial .....	175
Model 21P	46.0 mm Diameter Eleven Turn Dial .....	176
Model 23	Multidial 10 Turns 30.6 mm Diameter Projecting Design .....	177
Model 25	Model 25 (PR1) 46 mm Diameter, 20 Turn Dial .....	178
Model 26	Multidial 10 Turns 30.6 mm Diameter Recessed Design .....	179
Model 28	28 mm Diameter Twenty-One Turn Dial .....	180



## Technical Parameters - Definitions

### 1.1 PRECISION POTENTIOMETER

A mechanical-electrical transducer dependent upon the relative position of a moving contact (wiper) and a resistance element for its operation. It delivers to a high degree of accuracy, a voltage output that is some specified function of applied voltage and shaft position.

### 1.2 WIREWOUND PRECISION POTENTIOMETER

A precision potentiometer characterized by a resistance element made up of turns of wire on which the wiper contacts only a small portion of each turn.

#### 2.1 TOTAL APPLIED VOLTAGE “E”

The total voltage applied between the designated input terminals.

E = Total applied voltage (peak to peak applied voltage).

#### 2.2 OUTPUT VOLTAGE “e”

The voltage between the wiper and the designated reference point. Unless otherwise specified, the designated reference point is the CCW terminal.

#### 2.3 OUTPUT RATIO “e/E”

The ratio of the output voltage to the designated input reference voltage. Unless otherwise specified the reference voltage is the total applied voltage.

#### 2.4 CONFORMITY

The fidelity of the relationship between the actual function characteristic and the theoretical function characteristic.

Mathematically:

$$\frac{e}{E} = f(\theta) \pm C$$

#### 2.5 LINEARITY

A specific type of conformity where theoretical function characteristic is a straight line.

Mathematically:

$$\frac{e}{E} = f(\theta) \pm C = A(\theta) + B \pm C$$

Where A is a given slope; B is a given intercept at  $\theta = 0$ .

### 2.6 INDEPENDENT LINEARITY

The maximum deviation of the actual function characteristic from a straight reference line with its slope and position chosen to minimize the maximum deviations. It is expressed as a percentage of the total applied voltage and is measured over the specified theoretical electrical travel.

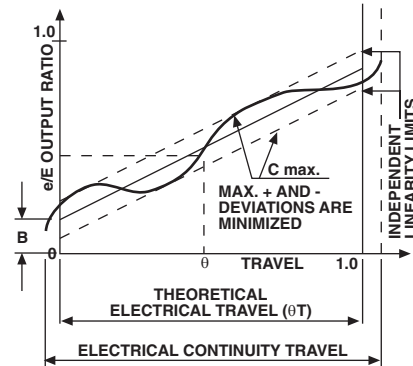

### 2.7 ABSOLUTE LINEARITY

This linearity is harder to achieve than the one above because it is the maximum deviation of the actual function characteristic from a fully defined straight reference line. It is expressed as a percentage of the total applied voltage and measured over the theoretical electrical travel. An index point on the actual output is required.

The straight reference line may be fully defined by specifying the low and high theoretical end output ratios separated by the theoretical electrical travel. Unless otherwise specified, these end output ratios are 0.0 and 1.0, respectively.

Mathematically:

$$\frac{e}{E} = A(\theta/\theta T) + B \pm C$$

Where A is a given slope; B is a given intercept at  $\theta = 0$ . Unless otherwise specified  $A = 1$ ;  $B = 0$ .

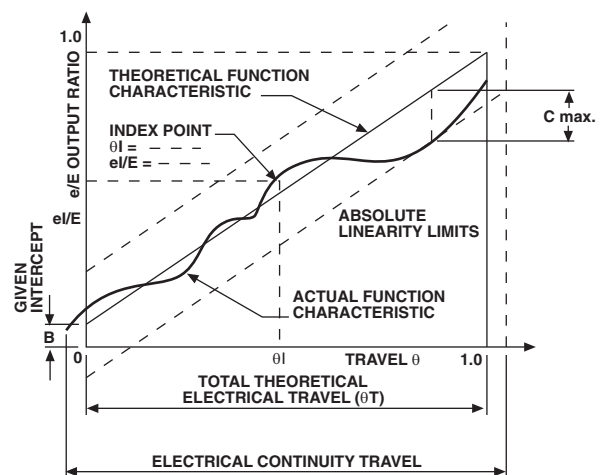

**2.8 GRADIENT**

The rate of change of output ratio relative to shaft travel.

$$G = \frac{de/E}{d\theta} \text{ (mV/V/}^\circ\text{)}$$

(rotational)

$$G = \frac{de/E}{d} \text{ (mV/V/mm)}$$

(linear)

**2.9 INDEX POINT**

A point of reference fixing the relationship between a specified shaft position and the output ratio. It is used to establish a shaft position reference.

**3.1 LIFE**

The number of shaft revolutions or translations obtainable under specific operating conditions and within specified allowable degradations of specific characteristics.

**3.2 RESOLUTION**

A measure of the sensitivity to which the output ratio of the potentiometer may be set.

Theoretically infinite for plastic film precision potentiometers. For wirewound: The reciprocal of the number of turns of wire in resistance winding in the actual electrical travel expressed as a percentage

$N = \text{total number of resistance wire turns}$   
 $1/N \times 100 = \text{Theoretical resolution percent}$

**3.3 REPEATABILITY**

It is the maximum difference found on the output ratio for a same mechanical position all along the theoretical electrical stroke after several travels. It is expressed as a percentage of the total applied voltage.

**3.4 OUTPUT SMOOTHNESS**

(non wirewound only)

Output smoothness is a measurement of any spurious variation in the electrical output not present in the input. It is expressed as a percentage of the total applied voltage and measured for specified travel increments over the theoretical electrical travel. Output smoothness includes effects of contact resistance variations, resolution, and other micrononlinearities in the output.

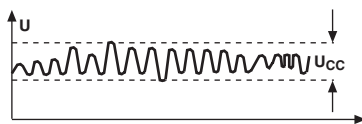

Ucc: maximum variations peak to peak.

$$RTS = \frac{U_{CC}}{E} \times 100 = \dots \%$$

**3.5 NOISE** (wirewound potentiometers only)

Any spurious variation in the electrical output not present in the input defined quantitatively in terms of an equivalent parasitic transient resistance in ohms, appearing between the contact and the resistance element when the shaft is rotated or translated (the wiper is excited by a specified current and moved at a specified speed).

**3.6 END VOLTAGE**

The voltage between the wiper terminal and an end terminal when the shaft is positioned at the corresponding end of electrical continuity travel. End voltage is expressed as a percentage of the total applied voltage.

**3.7 VOLTAGE TAP**

An electrical connection fixed to the resistance element which introduces no significant distortion in the output characteristic.

A voltage tap usually has significant tap resistance and may not be capable of carrying rated element current. A voltage tap involves a fourth turret which delivers a fixed voltage. This voltage only depends on the position of the tap on the track and of the total applied voltage. It is usually located at the middle of the TET.

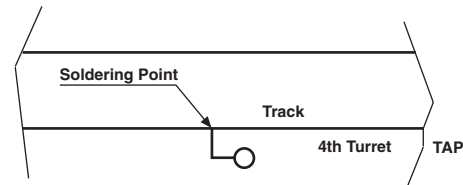

**3.8 CURRENT TAP**

An electrical connection fixed to the resistance element which is capable of carrying rated element current and may distort the output characteristic.

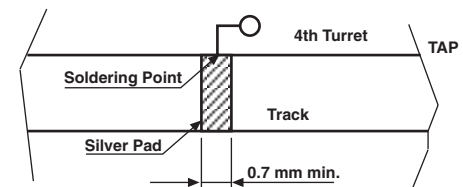

### 3.9 CONTACT RESISTANCE

The resistance appearing between the wiper and the resistive element when the shaft is rotated or translated. The wiper of the potentiometer is excited by a specific current and moved at a specified speed over a specified portion of the actual electrical travel.

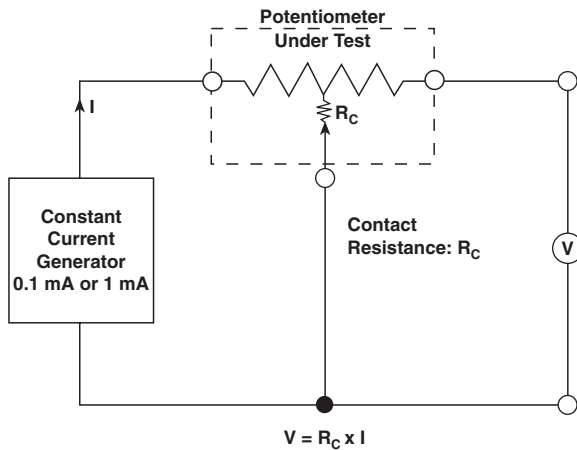

### 4.1 THEORETICAL ELECTRICAL TRAVEL: TET

The specified shaft travel over which the theoretical function characteristic and its associated conformity limits are respected.

### 4.2 ACTUAL ELECTRICAL TRAVEL: AET

The total travel of the shaft between the two points at which the first and the last measurable change in output ratio occur.

### 4.3 MECHANICAL TRAVEL: MT

The total travel of the shaft between integral stops. In potentiometers without stops, the mechanical travel is continuous (rotationals only!).

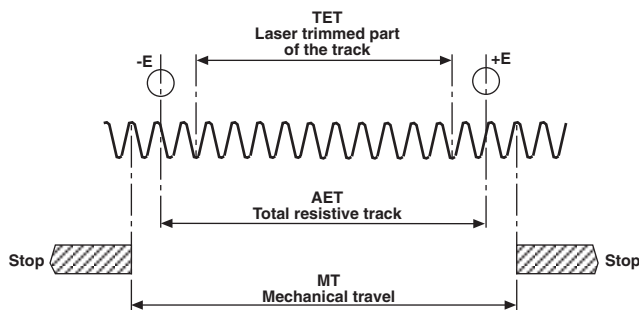

### 4.4 STARTING TORQUE

The moment in the clockwise and counterclockwise directions required to initiate shaft rotation anywhere in the total mechanical travel.

### 4.5 DIELECTRIC WITHSTANDING VOLTAGE

Ability to withstand under prescribed conditions a specified potential of a given characteristic between the terminals of each cup and the exposed conducting surfaces of the potentiometer, or between the terminals of each cup and the terminals of every other cup in the gang without exceeding a specified leakage current value.

### 4.6 INSULATION RESISTANCE

The resistance to a specified impressed DC voltage between the terminals of each cup and the exposed conducting surfaces of the potentiometer, or between the terminals of each cup and the terminals of every other cup in the gang under described conditions.

### 4.7 POWER RATING

The maximum power that a potentiometer can dissipate under specified conditions while meeting specified performance requirements.

### 4.8 OUTPUT IMPEDANCE

Maximum impedance between wiper and either end terminal with the input shorted, and measured at a specified voltage and frequency.

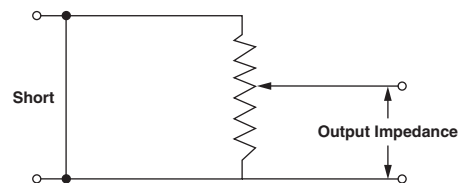

### 5.1 SHAFT RUNOUT

The eccentricity of the shaft diameter with respect to the rotational axis of the shaft, measured at a specified distance from the end of the shaft. The body of the potentiometer is held fixed and the shaft is rotated with a specified load applied radially to the shaft. The eccentricity is expressed in inches, TIR.



5.2 LATERAL RUNOUT

The perpendicularity of the mounting surface with respect to the rotational axis of the shaft, measured on the mounting surface at a specified distance from the outside edge of the mounting surface. The shaft is held fixed and the body of the potentiometer is rotated with specified loads applied radially and axially to the body of the pot. The Lateral Runout is expressed in inches, TIR.

5.3 PILOT DIAMETER RUNOUT

The eccentricity of the pilot diameter with respect to the rotational axis of the shaft, measured on the pilot diameter. The shaft is held fixed and the body of the potentiometer is rotated with a specified load applied radially to the body of the pot. The eccentricity is expressed in inches, TIR.

5.4 SHAFT RADIAL PLAY

The total radial excursion of the shaft, measured at a specified distance from the front surface of the unit. A specified radial load is applied alternately in opposite directions at a specified point. Shaft Radial Play is expressed in inches.

5.5 SHAFT END PLAY

The total axial excursion of the shaft, measured at the end of the shaft with a specified axial load supplied alternately in opposite directions. Shaft End Play is expressed in inches.

5.6 SEALING LEVELS

See below "Protection Levels"

PROTECTION LEVELS			
FIRST DIGIT Protection against solid substances		SECOND DIGIT Protection against liquids	
IP	Tests	IP	Tests
0	Without protection	0	Without protection
1	Protected against solid substances (size > 50 mm)	1	Protected against water drops (condensation)
2	Protected against solid substances (size > 12 mm)	2	Protected against water drops from up to 15 feet
3	Protected against solid substances (size > 2.5 mm)	3	Protected against water drops up to 60 feet
4	Protected against solid substances (size > 1 mm)	4	Protected against water drops above 60 feet
5	Protected against dust (> 0.1 mm < 1 mm)	5	Protected against splashes of water in all directions
6	Fully protected against dust	6	Protected against projections of water in all directions
		7	Protected against action of immersion < 15 cm and water jet pressure all directions
		8	Protected against long time action of immersion < 1 meter and water jet pressure in all directions

Note

- To symbolize the protection levels, we use ip letters followed by 2 digits.

Examples:

IP50 Sealing level: Protected against dust but not water.

IP65 Sealing level: Protected against dust and splashes of water in all directions.

These 2 levels are the most frequently met ones.

### VOLTAGE DIVIDER

In order to reach the same performances than the ones we achieve during final quality control, for parameters like: linearity, lifespan, micro linearity, all along the temperature range, our precision potentiometers must work accordingly to the principle of a voltage divider.

The drawing is showing one of the most common and recommended way to connect a precision potentiometer, the wiper output is connected to an operational amplifier, the high input impedance of the amplifier maintains the current at a low level (i.e.  $< 1 \mu\text{A}$ ).

Nearly all the current remains in the potentiometer track, the current in the wiper is too low to generate a significant disturbance and the potentiometer works as a voltage divider.

A recommended value for the load impedance is generally specified as 1000 times the total ohmic value of the potentiometer.

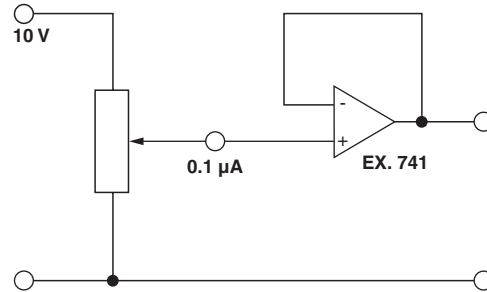

### MOUNTING TYPES

#### 1. Servo Mounting

3 clamps are screwed into the mounting plate after being inserted in the groove of the front plate. The potentiometer is centered on its flange diameter inside the mounting plate.

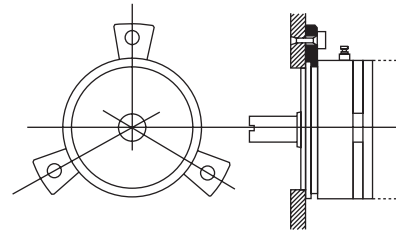

#### 2. Bushing Mount

The potentiometer is fixed on the mounting plate when the nut (+ washer) is screwed onto the bushing. The antirotation pin prevents the potentiometer from turning.

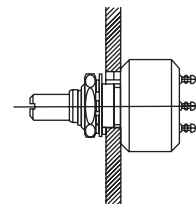

#### 3. Screw Mounting

The front plate of the potentiometer has 3 drilled holes, 3 screws are used to assemble the mounting plate together with the potentiometer.

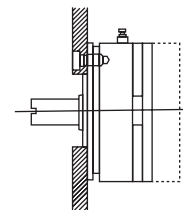



<b>GENERAL PERFORMANCES</b>	
Rotational Speed	600 RPM (Shaft guiding: Ball bearings); 150 RPM (Shaft guiding: Sleeve bearing)
Temperature Range	- 55 °C to + 125 °C
Temperature Coefficient	- 300 ppm/°C ± 500 ppm/°C
Resolution	Essentially infinite for conductive plastic technology
Lifespan	Depending on the model; up to 50 million revolutions
Drift of Performances Along Life	Some parameters like: linearity, contact resistance, ohmic value are changing along the life of the products, first two ones can typically increase by 50 % at mid life (20M cycles); third one can decrease by a few percents (negative TC).





# Plastic Film Technology Rotational



## Contents

### Industrial Models

Model 138 .....	12
Model 139 .....	14
Model 157 .....	16
Model 159 .....	18
Model 357 .....	21
Model 657 .....	23
Series ECO .....	25
Series ECS .....	28
Series KIT RMF .....	30

### Professional Models

Model 128 .....	32
Model 208 .....	35
Model 308 .....	38
Model 708 .....	41
Series ROT/BF .....	44
Series ROT/SF .....	46
Series 116 BFZ-SFZ .....	48



## 1 5/16" (33.3 mm) Industrial Single Turn, Bushing Mount, Conductive Plastic



### FEATURES

- Center tap available
- Continuous rotation and mechanical stops both standard
- Suitable model for all types of industrial applications



ELECTRICAL SPECIFICATIONS		
PARAMETER	MIL-PRF-39023 TEST PROCEDURES APPLY	
	STANDARD	SPECIAL
Ohmic Value Range	1 kΩ to 50 kΩ	1 kΩ to 50 kΩ
Tolerance	± 10 %	± 5 %
Linearity (Independent)	STANDARD	BEST PRACTICAL
	± 0.5 %	± 0.25 %
Output Smoothness	0.1 % maximum	
Power Rating	40 °C ambient 2 W derated to zero at 125 °C	
Electrical Angle		
Continuous	345° ± 4°	
Stops	340° ± 5°	
Insulation Resistance	1000 MΩ minimum at 500 V <sub>DC</sub>	
Dielectric Strength	1000 V <sub>RMS</sub> , 60 Hz	
Absolute Minimum Resistance	1.0 % of total resistance	
Minimum Voltage	0.5 % maximum	
Temperature Coefficient of Resistance	± 500 ppm/°C maximum	

MATERIAL SPECIFICATIONS	
Housing	Molded glass filled thermoplastic
Rear Lid	Glass filled thermoset plastic
Shaft	Stainless steel, non-magnetic
Terminals	Brass, plated for solderability, Non-passivated
Mount Hardware Lockwasher Internal Tooth: Panel nut:	Steel, nickel plated Brass, nickel plated

ENVIRONMENTAL SPECIFICATIONS	
Vibration	15 Gs thru 2000 Hz
Shock	50 g
Salt Spray	48 h
Rotational Life	2 million
Shaft Revolutions	
Operating Temperature Range	- 55 °C to + 125 °C

ORDERING INFORMATION/DESCRIPTION					
138	B	0	0	20K	BO10
MODEL	BUSHING MOUNT	MECHANICAL OPTIONS	OTHER OPTIONAL FEATURES	RESISTANCE CODE	PACKAGING
		0. Continuous 2. Stops	0. Standard (end taps) 1. Center tap (within 5° of electrical center)		Box of 10 pieces
Other characteristics will be standard as described on this specification sheet. If special characteristics are required such as special linearity tolerance, special resistance tolerance, non-linear functions, etc., please state these on your order.					

SAP PART NUMBERING GUIDELINES					
138	B	2	1	103	B10
MODEL	STYLE	MECHANICAL OPTIONS	FEATURES	OHMIC VALUE	PACKAGING
		With stops	With center tap		Box of 10 pieces



1 5/16" (33.3 mm) Industrial Single Turn,  
Bushing Mount, Conductive Plastic

Vishay Spectrol

**DIMENSIONS** in inches (millimeters)

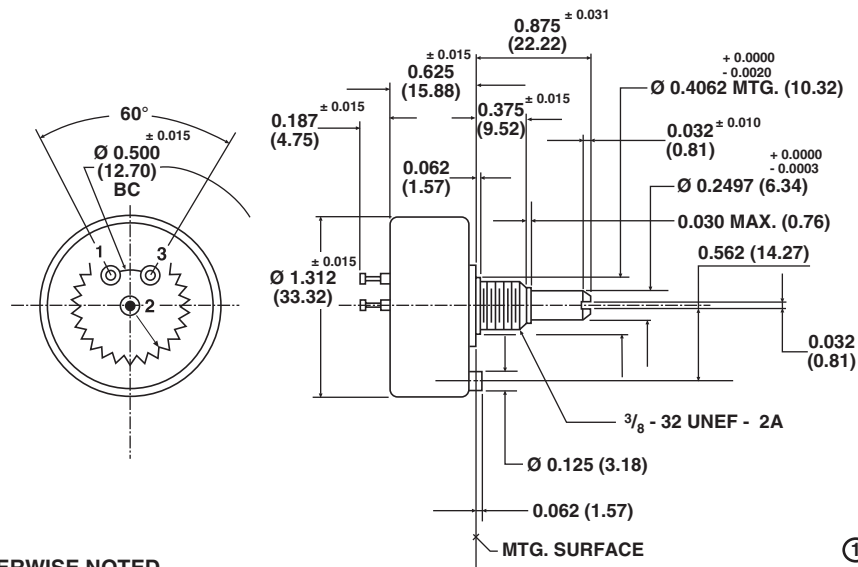

TOLERANCES: UNLESS OTHERWISE NOTED.  
DECIMALS ± 0.005 ANGLES ± 2°

MECHANICAL SPECIFICATIONS		
PARAMETER		
Rotation	360° (continuous) 340° ± 5° stops	
Bearing Type	Sleeve	
Torque (Maximums)	<b>STARTING</b> 1.0 oz. - in (72 g - cm)	<b>RUNNING</b> 0.7 oz. - in (50.40 g - cm)
Runouts (Maximums)		
Shaft Runout (TIR)	0.002" (0.05 mm)	
Pilot Dia. Runout (TIR)	0.003" (0.08 mm)	
Lateral Runout (TIR)	0.005" (0.13 mm)	
Shaft End Play	0.008" (0.20 mm)	
Shaft Radial Play	0.003" (0.08 mm)	
Weight	1.0 oz. maximum (28.35 g)	
Stop Strength	8.0 in - lbs (9.21 kg - cm) (stops version only)	

**POWER RATING CHART**

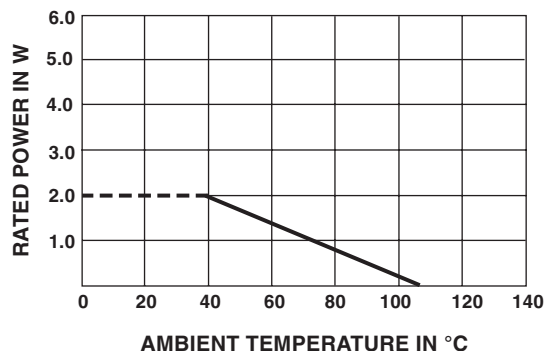

**MARKING**

<b>Unit Identification</b>	Units shall be marked with Vishay Spectrol name, model number, resistance and tolerance, linearity, terminal identification, and data code Applicable test procedures: MIL-R-39023
----------------------------	--

# Model 139

Vishay Spectrol



## 1 5/16" (33.3 mm) Industrial Single Turn Cermet Bushing Mount Model



This Model 139 is only for maintenance purposes. It is not recommended for new designs and will be obsolete in a near future.

### FEATURES

- Very high ohmic values available: up to 2 MΩ
- Center tap available
- Continuous rotation and mechanical stops both standard
- High power rating



ELECTRICAL SPECIFICATIONS		
PARAMETER	STANDARD	SPECIAL
Ohmic Value	500 Ω to 2 MΩ	500 Ω to 2 MΩ
Tolerance	± 20 %	± 5 %
Linearity (Independent)	<b>STANDARD</b> ± 0.5 %	<b>BEST PRACTICAL</b> ± 0.25 %
Output Smoothness	0.1 % maximum	
Power Rating	40 °C ambient 5 W derated to zero at 125 °C	
Electrical Rotation		
Continuous	345° ± 4°	
Stops	340° ± 5°	
Insulation Resistance	1000 MΩ minimum at 500 V <sub>DC</sub>	
Dielectric Strength	1000 V <sub>RMS</sub> , 60 Hz	
Absolute Minimum Resistance	1.0 % of total resistance	
Minimum Voltage	0.5 % maximum	
Temperature Coefficient of Resistance	± 100 ppm/°C maximum	

MATERIAL SPECIFICATIONS	
Housing	Molded glass filled thermoplastic
Rear Lid	Glass filled thermoset plastic
Shaft	Stainless steel, non-magnetic
Terminals	Brass, plated for solderability, Non-passivated
Mount Hardware Lockwasher Internal Tooth: Panel Nut:	Steel, nickel plated Brass, nickel plated

ENVIRONMENTAL SPECIFICATIONS	
Vibration	15 Gs thru 2000 Hz
Shock	50 g
Salt Spray	48 h
Rotational Life	2 million
Shaft Revolutions	
Operating Temperature Range	- 55 °C to + 125 °C

ORDERING INFORMATION/DESCRIPTION					
139	B	0	0	20K	BO10
MODEL	BUSHING MOUNT	MECHANICAL OPTIONS	OTHER OPTIONAL FEATURES	RESISTANCE CODE	PACKAGING
		0. Continuous 2. Stops	0. Standard (end taps) 1. Center tap (within 5° of electrical center)		Box of 10 pieces
Other characteristics will be standard as described on this specification sheet. If special characteristics are required such as special linearity tolerance, special resistance tolerance, non-linear functions, etc., please state these on your order.					

SAP PART NUMBERING GUIDELINES					
139	B	2	1	103	B10
MODEL	STYLE	MECHANICAL OPTIONS	FEATURES	OHMIC VALUE	PACKAGING
		With stops	With center tap		Box of 10 pieces



1 5/16" (33.3 mm) Industrial Single Turn  
Cermet Bushing Mount Model

Vishay Spectrol

**DIMENSIONS** in inches (millimeters)

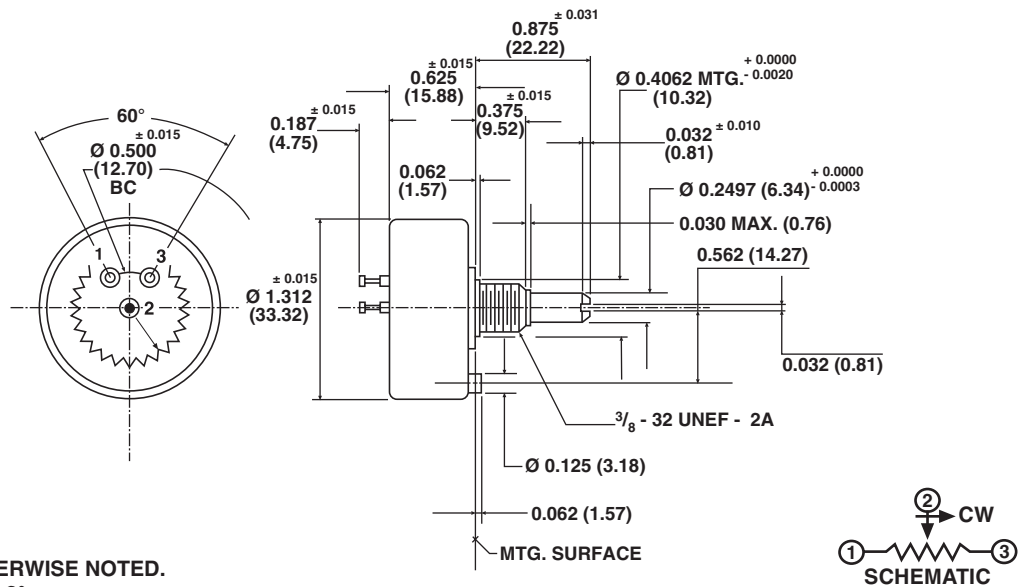

TOLERANCES: UNLESS OTHERWISE NOTED.  
DECIMALS ± 0.005 ANGLES ± 2°

MECHANICAL SPECIFICATIONS		
PARAMETER		
Rotation	360° (continuous) 340° ± 5° stops	
Bearing Type	Sleeve	
Torque (Maximums)	<b>STARTING</b> 1.0 oz. - in (72 g - cm)	<b>RUNNING</b> 0.7 oz. - in (50.40 g - cm)
Runouts (Maximums)		
Shaft Runout (TIR)	0.002" (0.05 mm)	
Pilot Dia. Runout (TIR)	0.003" (0.08 mm)	
Lateral Runout (TIR)	0.005" (0.13 mm)	
Shaft End Play	0.008" (0.20 mm)	
Shaft Radial Play	0.003" (0.08 mm)	
Weight	1.0 oz. maximum (28.35 g)	
Stop Strength	8.0 in - lbs (9.21 kg - cm) (stops version only)	

**POWER RATING CHART**

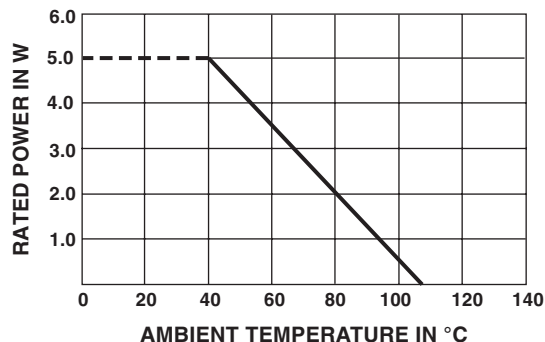

**MARKING**

<b>Unit Identification</b>	Units shall be marked with Vishay Spectrol name, model number, resistance and tolerance, linearity, terminal identification, and data code Applicable test procedures: MIL-R-39023
----------------------------	--

## 7/8" (22.2 mm) Precision Industrial Potentiometer Bushing and Servo Mount Versions, Conductive Plastic



### FEATURES

- High quality
- Rugged one piece metal housing
- Long rotational life
- Wide operating temperature range
- Linearities down to  $\pm 0.25\%$  special
- Optional sealed construction (bushing mount only)



ELECTRICAL SPECIFICATIONS	
PARAMETER	MIL-PRF-39023 TEST PROCEDURES APPLY
Resistance	1 k $\Omega$ to 100 k $\Omega$
Resistance Tolerance	$\pm 20\%$
Special to	$\pm 10\%$
Linearity	$\pm 2.0\%$
Special to	$\pm 0.25\%$
Temperature Coefficient of Resistance	$\pm 600$ ppm/ $^{\circ}$ C
Power Rating	1.0 W at 40 $^{\circ}$ C ambient
Derated to	0 W at 125 $^{\circ}$ C
Electrical Angle	340 $^{\circ}$ $\pm$ 4 $^{\circ}$
End Voltage	0.5 % maximum
Dielectric Withstanding	1000 V <sub>RMS</sub> , 60 Hz
Insulation Resistance	100 M $\Omega$ minimum, 500 V <sub>DC</sub>
Output Smoothness	0.1 %

MECHANICAL SPECIFICATIONS		
PARAMETER		
Weight	0.5 oz. maximum (14 g)	
Rotation	360 $^{\circ}$ (continuous)	
Mount	<b>BUSHING</b>	<b>SERVO</b>
Bearing Type	Sleeve bearing	Ball bearing
Operating Torque		
Starting	0.30 oz. - in (21.6 g - cm)	0.25 oz. - in (18 g - cm)
Running	0.25 oz. - in (18 g - cm)	0.15 oz. - in (10.8 g - cm)
Mechanical Tolerance (in/mm) (maximum)		
Shaft Runout (TIR)	0.002" (0.05 mm)	0.002" (0.05 mm)
Pilot Dia Runout (TIR)	-	0.002" (0.05 mm)
Lateral Runout (TIR)	0.005" (0.13 mm)	0.002" (0.05 mm)
Shaft End Play	0.006" (0.15 mm)	0.005" (0.13 mm)
Shaft Radial Play	0.003" (0.08 mm)	0.002" (0.05 mm)

ORDERING INFORMATION/DESCRIPTION					
157	B	50K	20 %	C	BO10
MODEL	MOUNTING	OHMIC VALUE	TOLERANCE	LINEARITY	PACKAGING
	B = Bushing S = Servo		ON OHMIC VALUE	C: $\pm 0.25\%$	Box of 10 pieces



**7/8" (22.2 mm) Precision Industrial Potentiometer Vishay Spectrol  
Bushing and Servo Mount Versions, Conductive Plastic**

<b>SAP PART NUMBERING GUIDELINES</b>					
<b>157</b>	<b>S</b>	<b>502</b>	<b>M</b>	<b>X</b>	<b>B10</b>
MODEL	STYLE	OHMIC VALUE	TOLERANCE ON OHMIC VALUE	LINEARITY	PACKAGING
		502 = 5K	M: ± 20 %	X: ± 2 %	Box of 10 pieces

**DIMENSIONS** in inches (millimeters)

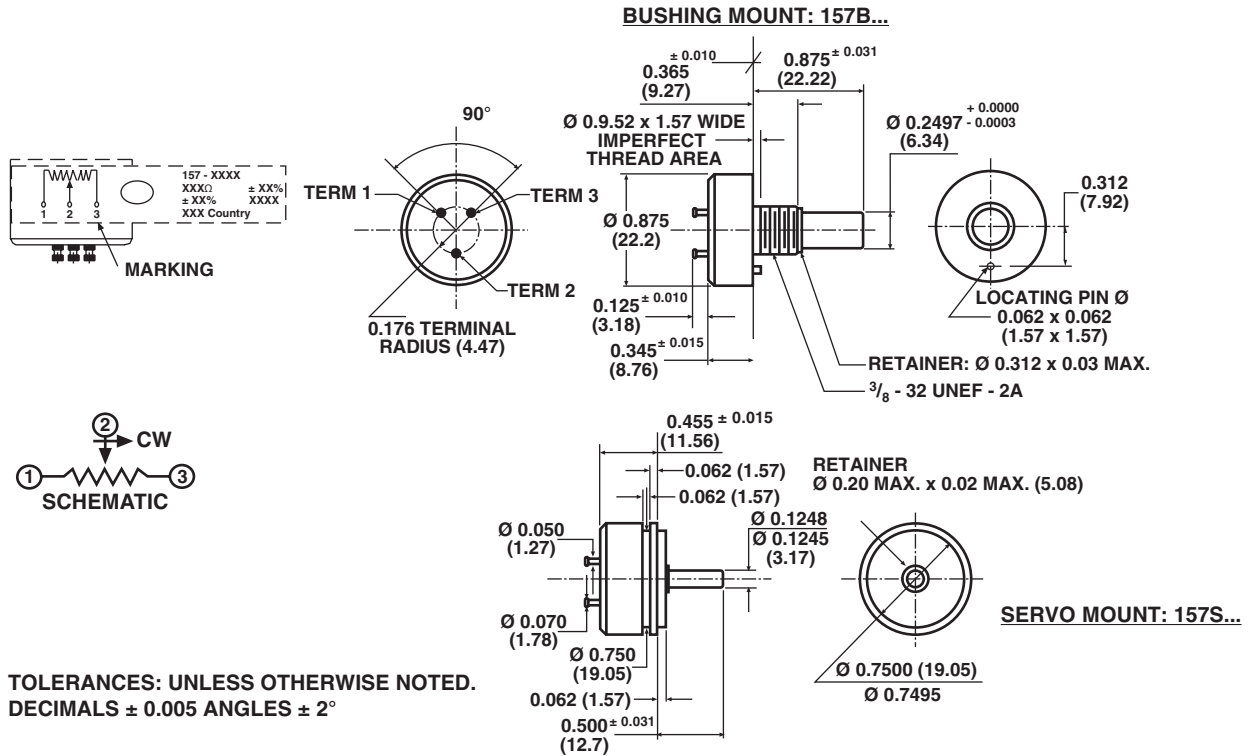

<b>MATERIAL SPECIFICATIONS</b>	
Housing/Bushing	Aluminum, anodized
Rear Lid	Ceramic
Shaft	Stainless steel
Terminals	Solderable
Bushing Mount Hardware	Lockwasher, internal tooth steel, nickel plated
Panel Nut	Brass, nickel plated

<b>ENVIRONMENTAL SPECIFICATIONS</b>		
Temperature	- 55 °C + 125 °C	
Rotational Life	<b>BUSHING</b> 5 million shaft revolutions	<b>SERVO</b> 10 million shaft revolutions
Moisture Resistant	Yes	
Vibration	15 g 10 to 2000 Hz	
Shock	50 g	
Salt Spray	96 h	
Load Life	900 h	



## 7/8" (22.2 mm) Single Turn Cermet Precision Potentiometer

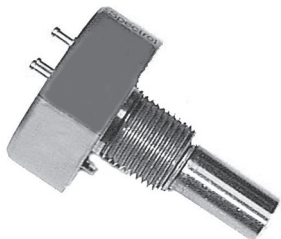

### FEATURES

- Rugged, high-quality, all metal housing
- Short length behind panel (11/32"/8.73 mm)
- High ohmic values up to: 2 MΩ
- Extra taps AVAILABLE



RoHS  
COMPLIANT

This Model 159 is only for maintenance purposes. It is not recommended for new designs and will be obsolete in a near future.

ELECTRICAL SPECIFICATIONS		
PARAMETER		
Standard Ohmic Values Range	500 Ω to 2 MΩ	
Tolerance	Standard: ± 20 %	Special: ± 5 %
Linearity (Independent)	<b>STANDARD</b>	<b>BEST PRACTICAL</b>
	± 0.5 %	± 0.25 %
Output Smoothness	0.1 % maximum	
Power Rating (at 40 °C Ambient)	3.5 W derated to zero at 150 °C	
Electrical Angle	340° ± 4°	
Insulation Resistance	1000 MΩ minimum 500 V <sub>DC</sub>	
Dielectric Strength	1000 V <sub>RMS</sub> , 60 Hz	
Minimum Voltage	0.5 % max.	
Temperature Coefficient of Resistance	± 100 ppm/°C	

ORDERING INFORMATION/DESCRIPTION			
The Models 159 can be ordered from this data sheet with a variety of alternate characteristics, as shown. For most rapid service on your order, please state:			
<b>159</b>	<b>B</b>	<b>10K</b>	<b>BO10</b>
MODEL	MOUNTING	OHMIC VALUE	PACKAGING
	<b>B</b> = Bushing <b>S</b> = Servo		Box of 10 pieces
Other characteristics will be standard as described on this data sheet. If special characteristics are required, such as: special linearity tolerance, special resistance tolerance, high torque, 1/8 shaft - 1/4 - 32 bushing, stops, non - linear functions, etc., state these on your order			

SAP PART NUMBERING GUIDELINES			
<b>159</b>	<b>S</b>	<b>205</b>	<b>B10</b>
MODEL	STYLE	OHMIC VALUE	PACKAGING
	Servo	2 MΩ	Box of 10 pieces



7/8" (22.2 mm) Single Turn  
Cermet Precision Potentiometer

Vishay Spectrol

**DIMENSIONS** in inches (millimeters)

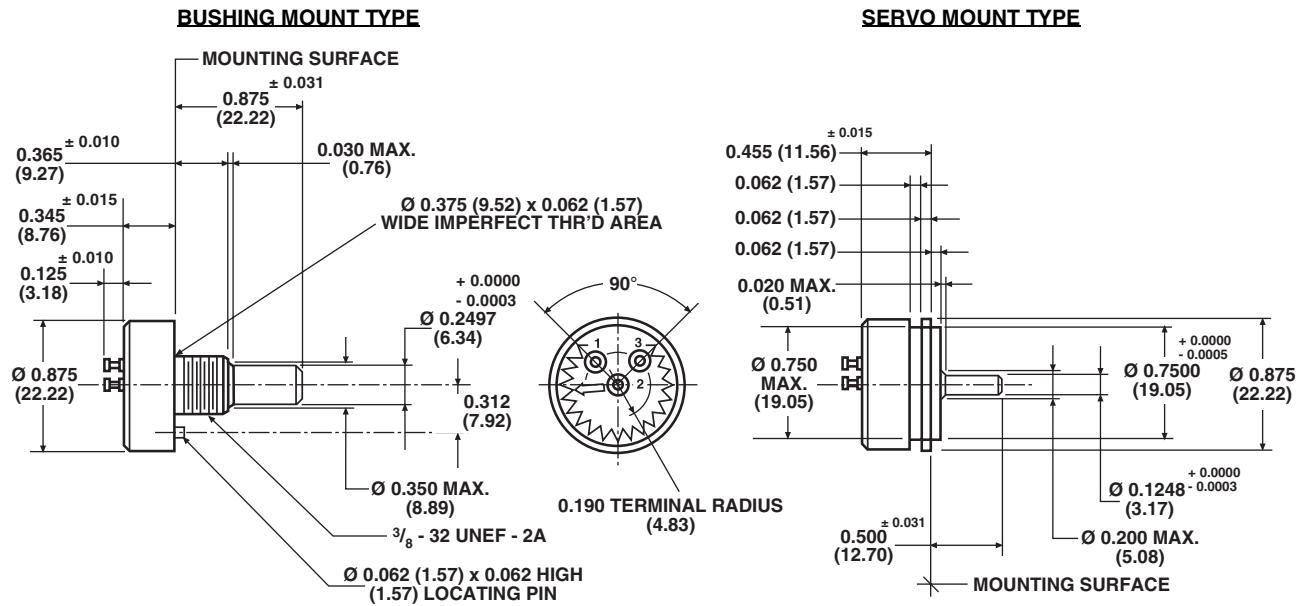

TOLERANCES: UNLESS OTHERWISE NOTED.  
DECIMALS ± 0.005 ANGLES ± 2°

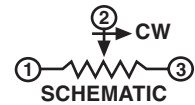

MECHANICAL SPECIFICATIONS		
PARAMETER		
Rotation	360° continuous	
Bearing Type	Servo mount: ball bearing Bushing mount: sleeve bearing	
Torque (Maximums)	<b>STARTING</b>	<b>RUNNING</b>
Servo	0.25 oz. - in (18.00 g - cm)	0.15 oz. - in (10.80 g - cm)
Bushing	0.30 oz. - in (21.60 g - cm)	0.25 oz. - in (18.00 g - cm)
Mechanical Runouts (Maximums)	<b>BUSHING</b>	<b>SERVO</b>
Shaft Runout	0.002" (0.05 cm)	0.002" (0.05 cm)
Pilot Dia. Runout	-	0.002" (0.05 cm)
Lateral Runout	0.005" (0.13 cm)	0.002" (0.05 cm)
Shaft End Play	0.006" (0.15 cm)	0.005" (0.13 cm)
Shaft Radial Play	0.003" (0.08 cm)	0.002" (0.05 cm)
Weight	0.5 oz. maximum (14.18 g)	



# Model 159



Vishay Spectrol

$\frac{7}{8}$ " (22.2 mm) Single Turn  
Cermet Precision Potentiometer

MATERIAL SPECIFICATIONS	
Housing	Aluminum, anodized
Shaft	Stainless steel, non-magnetic non-passivated
Rear Lid	Molded glass filled phenolic
Terminals	Brass, plated for solderability
Bushing Mount Hardware Lockwasher Internal Tooth: Panel Nut:	Steel, nickel plated Brass, nickel plated

ENVIRONMENTAL SPECIFICATIONS	
Vibration	15 g thru 2000 Hz
Shock	50 g
Salt Spray	96 h
Rotational Life Shaft Revolution:	<b>Bushing</b> <b>Servo</b> 2 million      5 million
Load Life	900 h
Operating Temperature Range	- 55 °C to - + 150 °C

## POWER RATING CHART

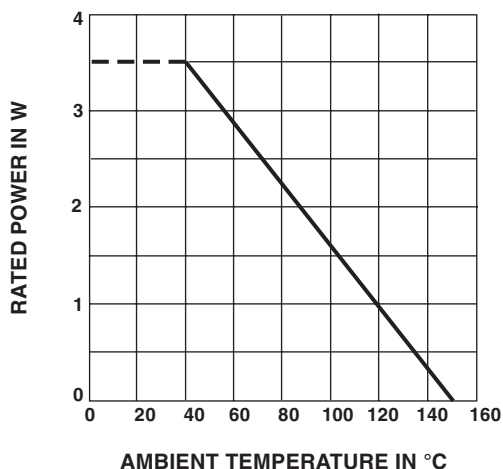

MARKING	
<b>Unit Identification</b>	Units shall be marked with Spectrol name, model number, resistance and tolerance, linearity terminal identification and data code. Applicable test procedures: MIL-R-39023

## 7/8" (22.2 mm) Conductive Plastic Potentiometer, Bushing Mount Type



### FEATURES

- 7/8" diameter single turn
- Compact size, advanced design technology
- Offer a cost effective solution to your potentiometer requirements
- Suitable model for all industrial applications



**RoHS**  
COMPLIANT

ELECTRICAL SPECIFICATIONS			
PARAMETER			
Resistance	Standard range, 1 kΩ to 50 kΩ		
Tolerance	<table border="1"> <tr> <td><b>STANDARD</b> ± 20 %</td> <td><b>SPECIAL TO</b> ± 10 %</td> </tr> </table>	<b>STANDARD</b> ± 20 %	<b>SPECIAL TO</b> ± 10 %
<b>STANDARD</b> ± 20 %	<b>SPECIAL TO</b> ± 10 %		
Linearity (Independent)	<table border="1"> <tr> <td><b>STANDARD</b> ± 2.0 %</td> <td><b>SPECIAL</b> ± 1.0 %</td> </tr> </table>	<b>STANDARD</b> ± 2.0 %	<b>SPECIAL</b> ± 1.0 %
<b>STANDARD</b> ± 2.0 %	<b>SPECIAL</b> ± 1.0 %		
Output Smoothness	0.1 % maximum		
TCR	± 600 ppm/°C maximum		
Power Rating	1.0 W at 70 °C derated to 0 W at 125 °C		
Electrical Travel	340° ± 3°		
End Voltage	0.5 % maximum		
Dielectric Withstanding Voltage	1000 V <sub>RMS</sub> , 60 Hz		
Insulation Resistance	1000 MΩ, 500 V <sub>DC</sub>		

MECHANICAL SPECIFICATIONS	
PARAMETER	
Rotation	360° continuous (optional mechanical stops 340° ± 3°)
Mounting	3/8 - 32 UNEF - 2A
Operating Torque Maximum	Starting and running 3.68 mNm (0.5 oz. - in)
Shaft Tolerance Maximum	
Runout	0.13 mm (0.005")
End Play	0.25 mm (0.010")
Radial Play	0.13 mm (0.005")
Weight	17.5 g (0.62 oz.)

ORDERING INFORMATION/DESCRIPTION								
357	B	0	10K	20 %	A	BO50	0 P 22	e4
MODEL	STYLE	FEATURES	OHMIC VALUE	TOLERANCE ON OHMIC VALUE	LINEARITY	PACKAGING	SHAFT TYPE	LEAD
	Bushing	0 Non turn pin and continuous rotation				Box of 50 pieces	Shaft diameter 0 = 6.0 mm or 1 = 6.35 (1/4")	Finish
		1 No non turn pin and continuous rotation	From 1K to 50 K	± 10 % or ± 20 %	X: ± 2 % A: ± 1 %		Shaft type P = plain S = slotted FMF (from Mounting face)	
		2 Non turn pin, with stops on rotation					Range from 12 mm to 75 mm in 1 mm increments	
		3 No non turn pin with stops on rotation						

SAP PART NUMBERING GUIDELINES						
357B	2	203	M	X	B25	1S22
MODEL	FEATURES	OHMIC VALUE	TOLERANCE ON OHMIC VALUE	LINEARITY	PACKAGING	SHAFT TYPE
		203 = 20K	M: ± 20 %/K: ± 10 %	X: ± 2 %	Box of 50 Pieces	

# Model 357

Vishay Spectrol

$\frac{7}{8}$ " (22.2 mm) Conductive Plastic Potentiometer, Bushing Mount Type



## DIMENSIONS in millimeters

### Ø 6.35 mm SHAFT VERSION

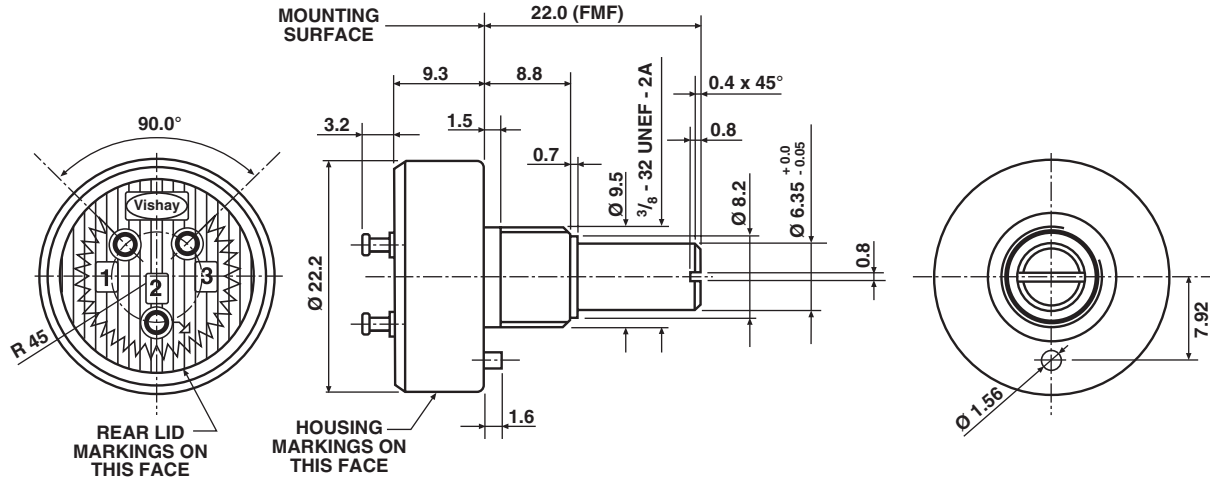

### Ø 6.0 mm SHAFT VARIATION: METRIC

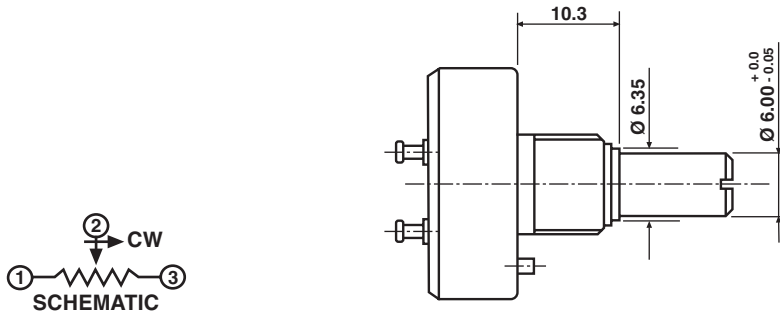

TOLERANCES: LINEAR  $\pm 0.50$   
ANGULAR  $\pm 2^\circ$

ENVIRONMENTAL SPECIFICATIONS	
Vibration	15 g, 10 to 2000 Hz
Shock	50 g
Load Life	1000 h
Storage Temperature Range	- 55 °C to + 125 °C
Life	5 000 000 shaft revolutions
Materials:	
Housing:	Thermoplastic housing
Bushing:	Brass, nickel plated
Rear Lid:	Alumina
Shaft:	Stainless steel
Terminals:	Turret type, solder plated
Bushing Mount Hardware	
Lockwasher Internal Tooth:	Steel, nickel plated
Panel Nut:	Brass nickel plated

MARKING	
Unit Identification	Manufacturer's name and model number, resistance value and tolerance, linearity specification date code and terminal identification

RESISTANCE VALUE	
Ohms	1K, 2K, 5K, 10K, 20K, 50K

## Industrial Rotary Position Sensor Bushing Mount Type, Conductive Plastic

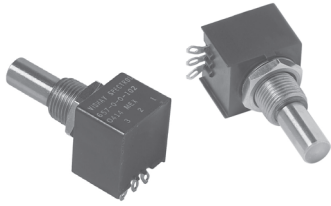



### FEATURES

- Fully sealed for high immunity to environmental damage
- Excellent temperature stability
- Rotational life exceeds 2 million revolutions
- Low cost and wide range of options
- Stainless steel shaft
- Shock to 30 G's vibration to 15 G's at 10 to 2000 Hz

<b>ELECTRICAL SPECIFICATIONS</b>	
PARAMETER	
Standard Resistance	1 k $\Omega$ to 100 k $\Omega$
Capability Range	200 k $\Omega$
Resistance Tolerance	$\pm 20\%$
Linearity	$\pm 2\%$
Power Rating	1.0 W at 85 °C
Electrical Travel	240° $\pm$ 4°
Dielectric Withstanding	500 V <sub>RMS</sub> at 60 Hz minimum
Output Smoothness	0.2 % maximum

<b>MECHANICAL SPECIFICATIONS</b>	
PARAMETER	
Bearing Type	Sleeve
Mechanical Rotation	250° $\pm$ 2°
Stop Strength	10 in - lb minimum 11.5 kg/cm
Starting Torque	3.0 o.z - in maximum 216 g/cm
Running Torque	3.0 oz. - in maximum 216 g/cm

<b>ORDERING INFORMATION/DESCRIPTION</b>							
657	B	F				50 k $\Omega$	BO10
MODEL	STYLE	SHAFT OPTIONS	SHAFT BUSHING OPTIONS			TOTAL RESISTANCE	PACKAGING
	B: Bushing	R - Round F - Flatted	 Shaft Length 0 - 0.875" FMS 1 - 0.625" FMS 2 - 1.000" FMS 3 - 1.250" FMS	 Bushing Length 0.375" FMS 0.250" FMS 0.500" FMS 0.750" FMS	 Flat 0.440" 0.315" 0.440" 0.440"		Box of 10 pieces

<b>SAP PART NUMBERING GUIDELINES</b>				
657B	R	1	103	BO10
MODEL	END SHAFT	SHAFT AND BUSHING OPTIONS	OHMIC VALUE	PACKAGING
	R: Round	(see above)		

# Model 657



Vishay Spectrol

Industrial Rotary Position Sensor  
Bushing Mount Type, Conductive Plastic

**DIMENSIONS** in inches (millimeters)

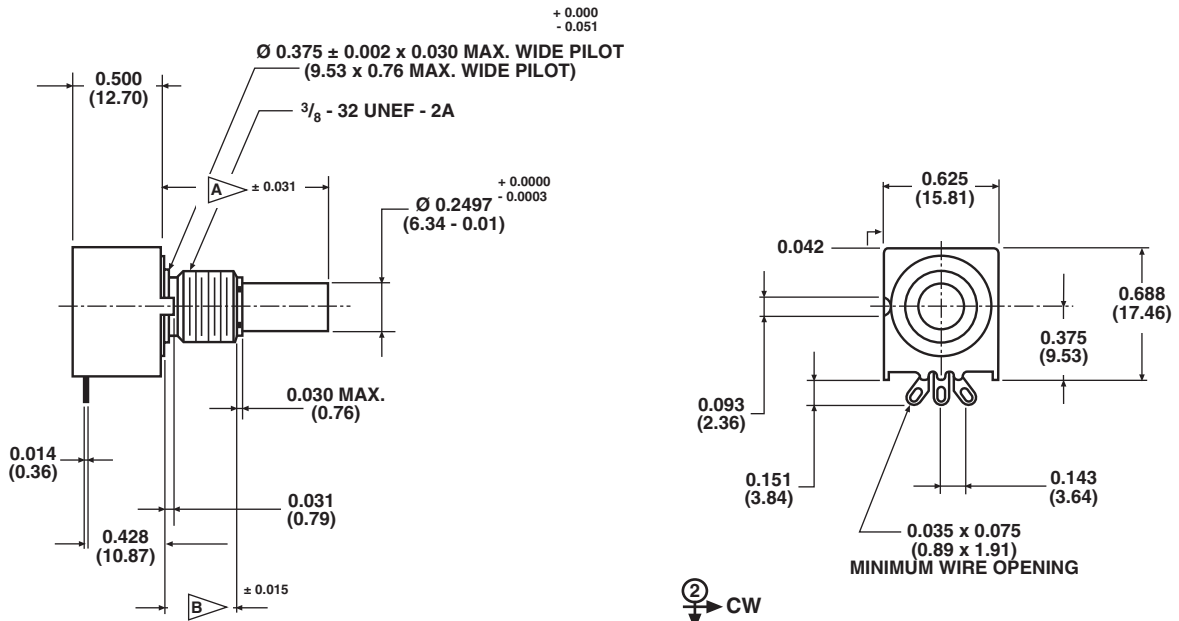

DECIMALS: XX ± 0.01 INCHES (± 0.25 mm)  
XX ± 0.005 INCHES (± 0.13 mm) ANGLES: ± 2°

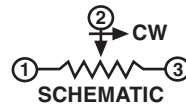

**SHAFT FLAT AND PHASING DIAGRAM**

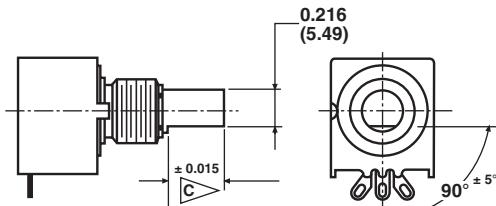

WITH SHAFT FLAT POSITIONED AS SHOWN, OUTPUT RATIO  
TO BE e/E = 0.50 ± 0.02



STANDARD RESISTANCE VALUES	
CODE	RESISTANCE (Ω)
102	1K
202	2K
502	5K
103	10K
203	20K
503	50K
104	100K

ENVIRONMENTAL SPECIFICATIONS	
Rotational Life	2 million revolutions
Vibration	15 G's at 10 to 2000 Hz
Operating Temperature	- 40 °C to + 125 °C
Storage Temperature	- 55 °C to + 150 °C
Temperature Coefficient	± 600 ppm/°C
Shock	30 G's
Resistant to Solder Heat	350 °C for 5 s
Moisture Resistance IP Rating	Sealed construction IP67* application to provide protection for wiring terminals

MATERIAL SPECIFICATIONS	
Shaft	Stainless steel
Bushing	Nickel plated brass
Housing	Thermoplastic
Element	Conductive plastic on alumina substrate

MARKING	
Unit Identification	Vishay Spectrol, part number, data code, country of origin and terminal designation

## Precision Rotative Transducers, Conductive Plastic, Economic Series (ECO)



### FEATURES

- Size 05 - 09 - 13 are available
- Long Life up to 30 million cycles
- Accuracy  $\pm 1\%$  down to  $\pm 0.25\%$
- Bush or servo mounting types
- Rear mounted terminals
- Following MIL-R-39023 and NFC 93-255 requirements



The “ECO” models are a comprehensive range of rotational motion transducers for industrial applications.

All mechanical and electrical parameters can be adapted to meet your specifications.

SIZE	05		09			13		
MODEL	50 ES	50 CB	78 ES	78 CS	78 CB	156 ES	156 CS	156 CB

ELECTRICAL SPECIFICATIONS							
Theoretical Electrical Angle (TEA)	Actual electrical angle (AEA) - 2°						
Independent Linearity (over TEA)	A $\leq \pm 1\%$ (standard)		B $\leq \pm 0.5\%$ (special)			C $\leq \pm 0.25\%$ (special)	
Actual Electrical Angle (AEA)	330° $\pm 5^\circ$		340° $\pm 5^\circ$			350° $\pm 5^\circ$	
Ohmic Values ( $R_T$ )	1 k $\Omega$ - 5 k $\Omega$ - 10 k $\Omega$ - on request other values						
Ohmic Value Tolerances at 20 °C	$\pm 10\%$	$\pm 20\%$	$\pm 10\%$	$\pm 20\%$	$\pm 10\%$	$\pm 20\%$	
Output Smoothness	$\leq 0.05\%$						
Maximum Power Rating at 70 °C	0.2 W		0.3 W			0.5 W	
Wiper Current	Recommended: a few $\mu\text{A}$ - 1 mA max. (continuous)						
Tap (Current or Voltage)	NA		1 (on request)				
Resistance Load on Wiper	Minimum $10^3 \times R_T$						
End Voltage	$\leq 0.2\%$	$\leq 0.5\%$	$\leq 0.2\%$	$\leq 0.5\%$	$\leq 0.2\%$	$\leq 0.5\%$	
Insulation Resistance	$\geq 1000 \text{ M}\Omega$ , 500 V <sub>DC</sub>						
Dielectric Strength	$\geq 500 \text{ V}_{\text{RMS}}$ , 50 Hz						

MECHANICAL SPECIFICATIONS							
Mechanical Angle (MA)	360° continuous						
On Request: Stops	NA		340° $\pm 3^\circ$			350° $\pm 3^\circ$	
Mounting Type	Servo	Bushing	Servo	Bushing	Servo	Bushing	
Shaft Guiding	Ball bearings	Sleeve bearings	Ball bearings	Sleeve bearings	Ball bearings	Sleeve bearings	
Shaft	Stainless steel						
Housing	Plastic moulding						
Termination	Turrets						
Wiper	Precious metal multi-finger contact						
Starting Torque (N.cm)	$\leq 0.2$	$\leq 0.5$	$\leq 0.2$	$\leq 0.5$	$\leq 0.2$	$\leq 0.5$	
Torque on Stops (N.cm)	50						
Weight (g)	5 $\pm 2$	8 $\pm 2$	13 $\pm 2$	17 $\pm 2$	29 $\pm 2$	34 $\pm 2$	
Moment of Inertia (g cm <sup>2</sup> )	$\leq 0.5$		$\leq 1$			$\leq 2$	

PERFORMANCE		
Life (10 <sup>6</sup> Cycles)	30 (on ES models)	20 (on CS and CB models)
Temperature Range	- 55 °C to + 125 °C	
Climatic Category	55/125/04	
Speed Rotation (RPM)	600 (on ES models)	150 (on CS and CB models)
Sine Vibration on 3 Axes	1.5 mm or 20 g from 10 Hz to 2000 Hz	
Mechanical Shocks on 3 Axes	50 g - 11 ms - half sine	

**DIMENSIONS** in millimeters, general tolerance  $\pm 0.5$  mm

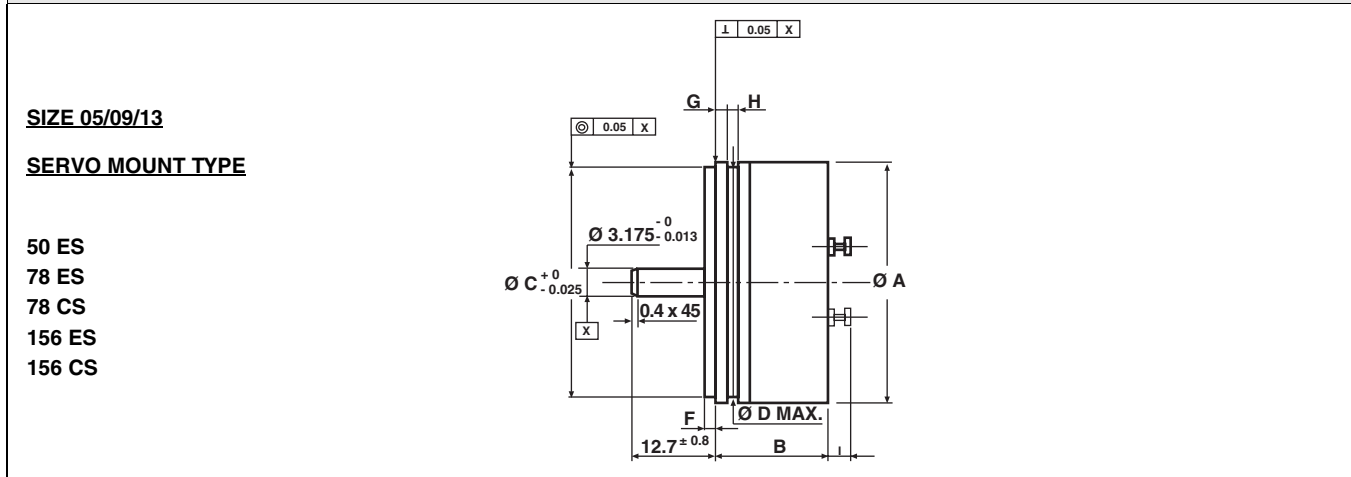

DIMENSIONS	DESIGNATION	SIZE 05	SIZE 09		SIZE 13	
		50 ES	78 ES	78 CS	156 ES	156 CS
Ø A	Ø housing	12.7	22.2		33.3	
B	Length	13.0	13.5		18.0	
Ø C	Ø pilot	9.525	19.05		30.16	
Ø D max.	Ø groove	11.45	19.64		30.9	
F	Flange thickness	1 ± 0.1			1.6 ± 0.1	
G	Shoulder	1.2 ± 0.1			1.6 ± 0.1	
H	Dia. of groove	1.2 ± 0.2			1.5 min.	
I max.	Height of the turret	2.5	2.5		3.6	

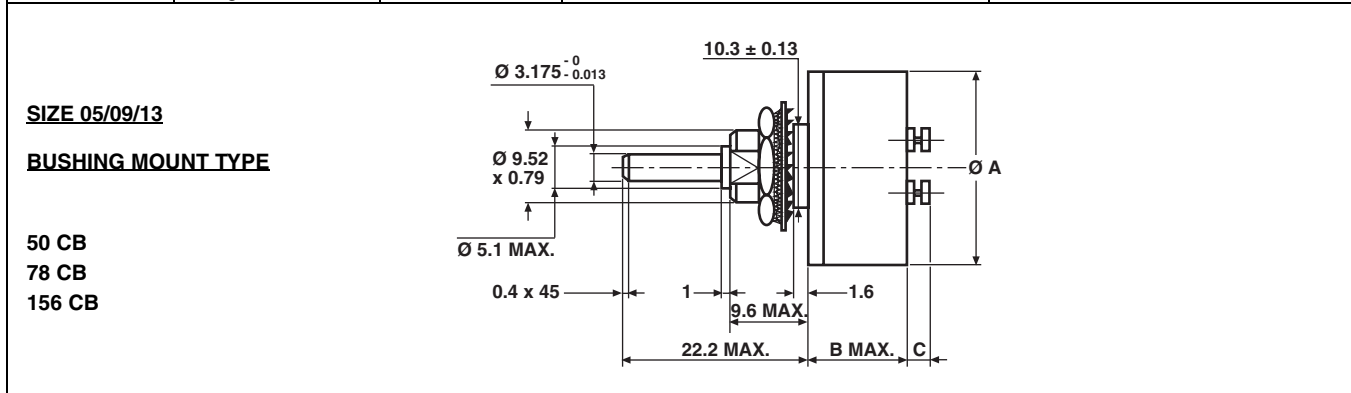

DIMENSIONS	DESIGNATION	SIZE 05	SIZE 09	SIZE 13
		50 CB	78 CB	156 CB
Ø A	Ø housing	12.7	22.2	33.3
B max.	Length	11	11.5	16
C max.	Height of the turret	2.5	2.5	3.6

**DIMENSIONS** in millimeters, general tolerance  $\pm 0.5$  mm

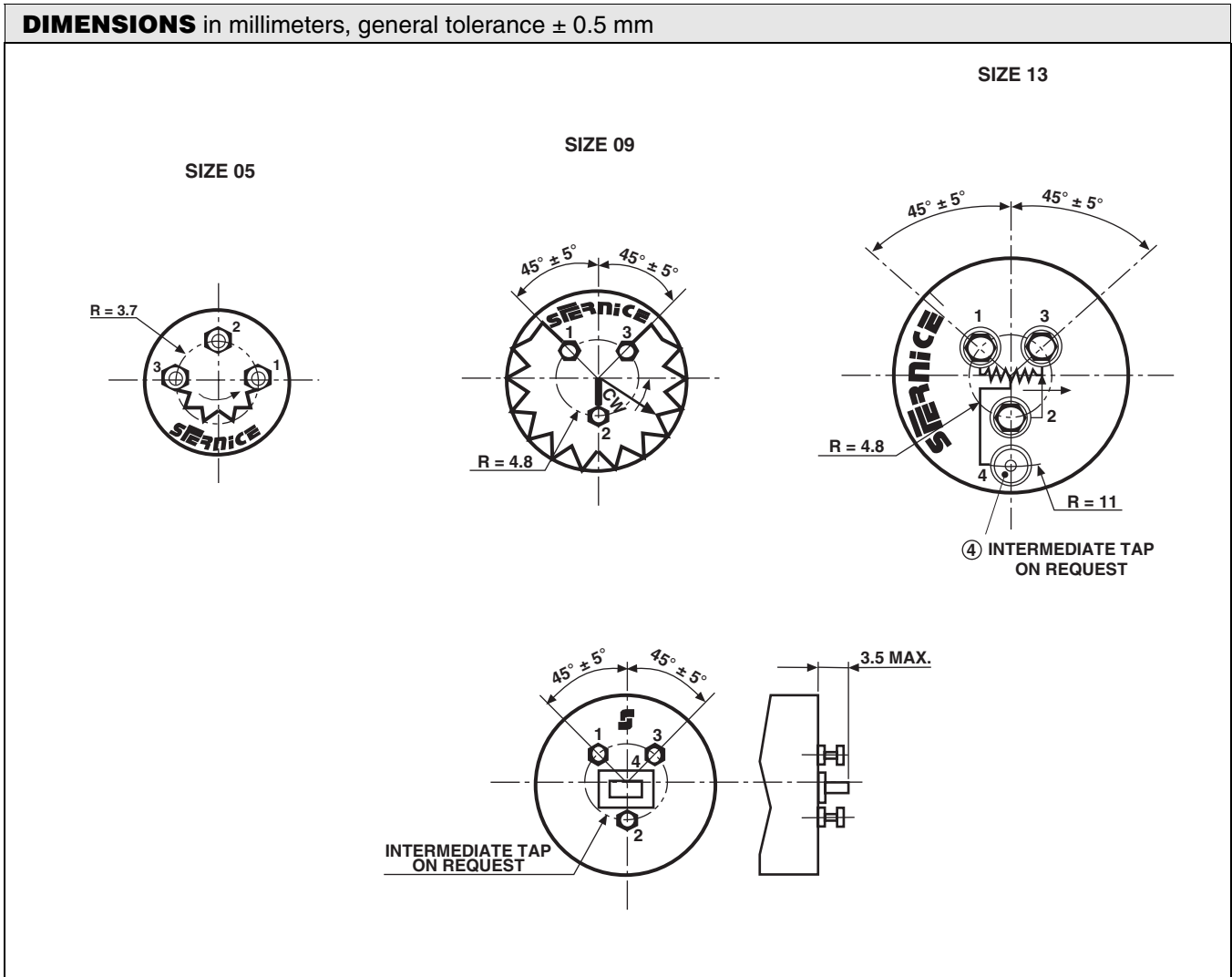

**ORDERING INFORMATION/DESCRIPTION**

ECO	78	E	S	A	T	103	e4
SERIES	MODEL	TYPE	FIXATION	LINEARITY	TAP	OHMIC VALUE	LEAD
		E = Ball bearings C = Sleeve bearings	S: Servo B: Bushing	Code A: $\pm 1\%$ B: $\pm 0.5\%$ C: $\pm 0.25\%$	On request T: Voltage U: Current position to be specified	First 2 digits are significant numbers 3rd digit indicates number of zeros	Finish

**SAP PART NUMBERING GUIDELINES**

ECO	78CB	C	502
SERIES	MODEL	LINEARITY	OHMIC VALUE



## Precision Rotative Transducers, Conductive Plastic, Economic Series (ECS)



### FEATURES

- Size 09: (7/8") 22,2 mm
- Long life: 5 million cycles
- Bush or servo mounting types available
- Rear comolded terminals
- Cost effective solution for any industrial applications



Low cost industrial motion transducers, conductive plastic track.

SIZE	09			
MODEL	78 RS	78 RB	78 PS	78 PB

ELECTRICAL SPECIFICATIONS	
Theoretical Electrical Angle (TEA)	(AEA) - 3°
Independent Linearity (over TEA)	A ≤ ± 1 %, on request: B ≤ ± 0.5 % C ≤ ± 0.35 % A ≤ ± 2 %
Actual Electrical Angle (AEA)	340° ± 5°
Ohmic Values (R <sub>T</sub> )	1 - 2 - 5 - 10 kΩ (on request other values) 1 - 2 - 5 - 10 kΩ
Ohmic Value Tolerances at 20 °C	Standard: ± 20 %/special: ± 10 % ± 20 %
Output Smoothness	0.1 %
Maximum Power Rating at 70 °C	0.3 W
Wiper Current	Recommended: a few μA - 1 mA max. (continuous)
Tap (Current or Voltage)	1: On request NA
Resistance Load on Wiper	≥ 1000 x R <sub>T</sub>
End Voltage	≤ 0.5 %DC
Insulation Resistance	≥ 1000 MΩ, 500 V <sub>DC</sub>
Dielectric Strength	≥ 500 V <sub>RMS</sub> , 50 Hz

MECHANICAL SPECIFICATIONS	
Mechanical Angle (MA)	360° continuous
On Request: Stops	342° ± 5°
Mounting Type	Servo Bushing Servo Bushing
Shaft Guiding	Sleeve bearings
Shaft	Stainless steel
Option: Flat or Screw Driver Slot On Shaft	On request NA
Termination	Turrets
Wiper	Precious metal multi-finger contact
Starting Torque (N.cm)	≤ 0.5
Torque on Stops (N.cm)	≥ 20
Weight (g)	Bushing 17 g ± 3 g Servo 12 g ± 3 g

PERFORMANCE	
Life (10 <sup>6</sup> Cycles)	5
Temperature Range	- 55 °C to + 125 °C
Climatic Category	55/125/04
Speed Rotation (RPM)	150
Sine Vibration on 3 Axes	15 g from 10 Hz to 2000 Hz
Mechanical Shocks on 3 Axes	50 g - 11 ms - half sine

#### DIMENSIONS in millimeters, general tolerance $\pm 0.5$ mm

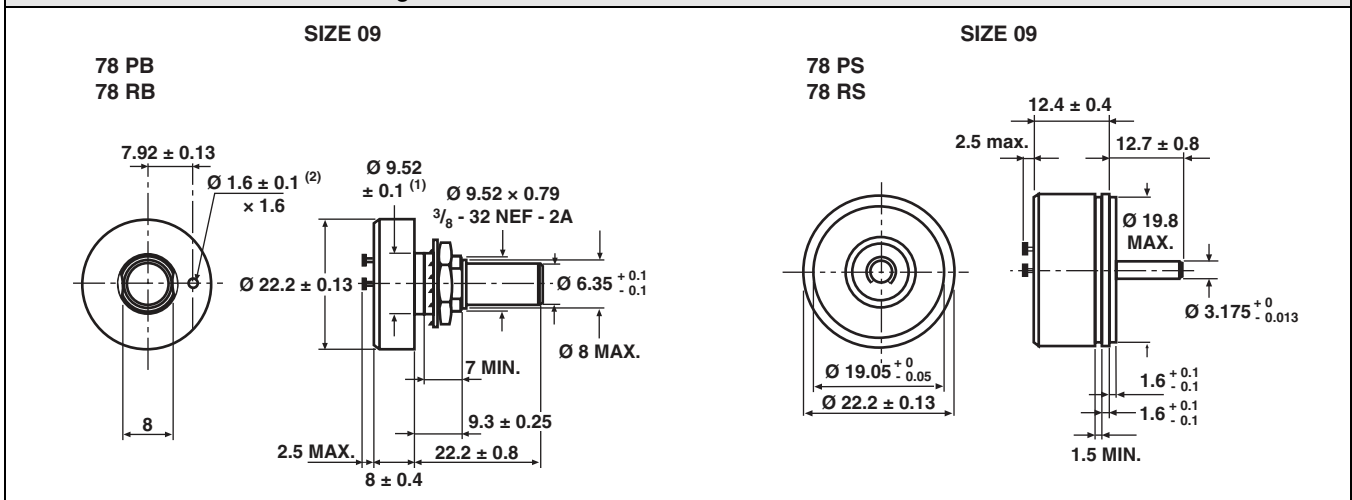

**Notes:**

- (1) On request:  $\varnothing$  10.3 mm or 12.3 mm
- (2) On request: without antirotation pin

#### REAR VIEW DIMENSIONS in millimeters, general tolerance 0.5 mm

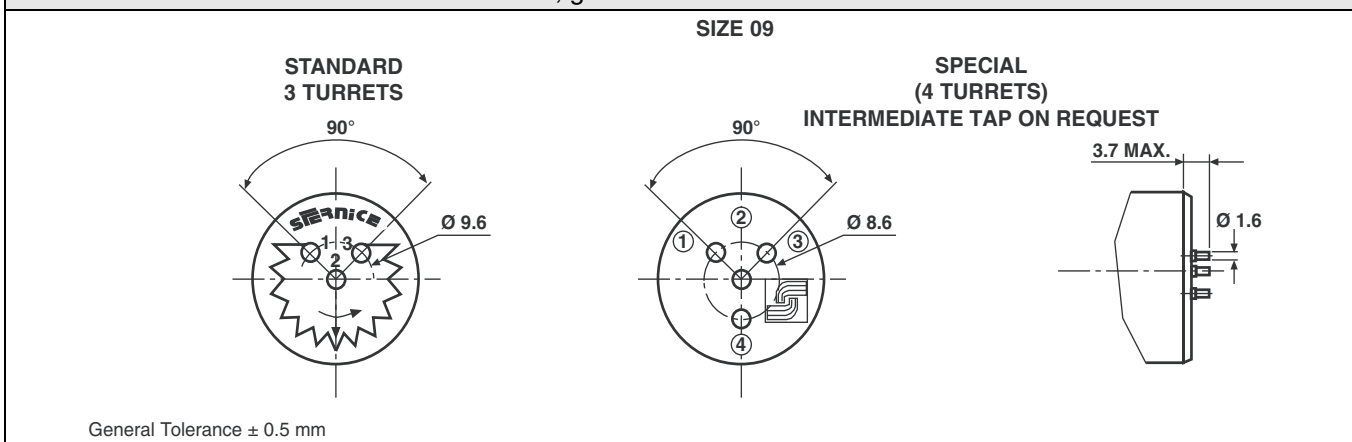

#### ORDERING INFORMATION/DESCRIPTION

ECS	78	P	S	M	A	T	103	e4
SERIES	MODEL	TYPE	FIXATION	MECHANICAL STOPS	LINEARITY	TAP	OHMIC VALUE	LEAD
		P	S: Servo	On request	A: $\pm 1\%$ or $\pm 2\%$	On request	102: 1 k $\Omega$	Finish
		R	B: Bushing	M	B: $\pm 0.5\%$	T: Voltage	202: 2 k $\Omega$	
					C: $\pm 0.35\%$	U: Current	502: 5 k $\Omega$	
						position to be specified	103: 10 k $\Omega$	

#### SAP PART NUMBERING GUIDELINES

ECS	78RB	B	102
SERIES	MODEL	LINEARITY	OHMIC VALUE

## Conductive Plastic Rotative Transducer Elements (KIT)



The RMF is a precision rotative motion transducer designed for easy mounting into your equipment.

### FEATURES

- Reduced dimensions and weight
- Cost effective solution
- Easy mounting
- Model dedicated to custom design requirements

It is made of 2 parts:

- A sensing element in a housing
- A wiper

On request, their shapes and sizes can be custom-designed to fit your equipment.

ELECTRICAL SPECIFICATIONS	
Theoretical Electrical Angle (TEA = E)	AEA - 2°
Independent Linearity over TEA On Request (Depending on Size)	A ≤ ± 1 %; B ≤ ± 0.5 % C ≤ ± 0.25 %; D ≤ ± 0.1 % down to E ≤ ± 0.05 %
Actual Electrical Angle (AEA)	340 ± 3° or 350 ± 2° according to the model
Total Resistance R <sub>T</sub> On Request	1 kΩ, 2 kΩ, 5 kΩ, 10 kΩ other values
Total Resistance Tolerance at 20 °C	± 20 %
Repeatability	< 0.01 %
Wiper Current	1 mA max. continuous, recommended: a few μA
Load Impedance	1000 times R <sub>T</sub> minimum
Insulation Resistance	> 1000 MΩ 500 V <sub>DC</sub>
Dielectric Strength	> 500 V <sub>RMS</sub> at 50 Hz

MECHANICAL SPECIFICATIONS	
Mechanical Angle MA	360° continuous
Substrate	Thermosetting resin
Termination On Request	Turrets wires, cables
Wiper	Multi-finger precious metal alloy

PERFORMANCE	
Life	25 million cycles typical
Temperature Limits	- 30 °C at + 85 °C



**EXAMPLES OF SPECIAL DESIGNS**



<b>ORDERING INFORMATION/DESCRIPTION</b>					
<b>KIT</b>	<b>RM</b>	<b>F</b>	<b>116</b>	<b>D</b>	<b>103</b>
SERIES	MODEL	TYPE	SIZE	LINEARITY	RESISTANCE
		F: Plastic S: Serigraphy		A: $\leq \pm 1\%$ B: $\leq \pm 0.5\%$ C: $\leq \pm 0.25\%$ D: $\leq \pm 0.1\%$ E: $\leq \pm 0.05\%$	First 2 digits are significant numbers Third indicates number of zeros

<b>SAP PART NUMBERING GUIDELINES</b>				
<b>RMS</b>	<b>200</b>	<b>A</b>	<b>502</b>	
MODEL	SIZE	LINEARITY	OHMIC VALUE	

## 1 1/16" (27 mm) Single Turn Conductive Plastic Precision Potentiometer

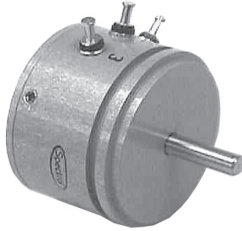

### FEATURES

- 1 1/16" round
- Bushing mount and servo mount types
- Designed for high reliability applications
- Ohmic value range: 500 Ω to 50 kΩ
- Rotational life exceeds 20 million shaft revolutions
- Virtually infinite resolution
- Up to 6 sections available
- Co-molded track and multi-finger wiper provide low noise signal



RoHS  
COMPLIANT

ELECTRICAL SPECIFICATIONS		
PARAMETER	STANDARD	SPECIAL
Total Resistance:	500 Ω to 50 kΩ	
Tolerance	± 10 %	± 5 %
Linearity (Independent)	± 0.5 %	± 0.15 %
Electrical Angle	345° ± 4°	
Power Rating	1.25 W at 70 °C ambient, derated to zero at 125 °C ambient	
Section 1:	1.25 W at 70 °C ambient, derated to zero at 125 °C ambient	
Additional Section:	75 % of the rating of section 1	
Output Smoothness	0.1 % maximum	
Insulation Resistance	1000 MΩ min, 500 V <sub>DC</sub>	
Dielectric Strength	1000 V <sub>RMS</sub> , 60 Hz	
Phasing (CCW End Points)	Points at which output ratio is 0.5 aligned ± 1° (ref. section 1)	
Temperature Coefficient of Resistance	± 400 ppm/°C maximum	
Taps (Extra)	Extra taps available as special	

ORDERING INFORMATION/DESCRIPTION				
The Model 128 can be ordered from this data sheet with a variety of alternate characteristics, as shown above. For most rapid service on your order, please state:				
<b>128</b>	<b>S</b>	<b>1</b>	<b>1K</b>	<b>B01</b>
MODEL	MOUNTING	NUMBER OF SECTIONS	TOTAL RESISTANCE OF EACH SECTION	PACKAGING
	<b>B:</b> Bushing <b>S:</b> Servo	Up to 6	Beginning with the section nearest the mounting end	Box of 1 piece
Other characteristics will be standard as described on this data sheet. If special characteristics are required, such as: special linearity tolerance, special resistance tolerance, extra taps, non-linear functions, etc., please state these on your order and allow additional lead time for delivery.				

SAP PART NUMBERING GUIDELINES						
<b>128</b>	<b>S</b>	<b>3</b>	<b>103</b>	<b>102</b>	<b>203</b>	<b>B01</b>
MODEL	STYLE	GANGS	OHMIC VALUE GANG N° 1	OHMIC VALUE GANG N° 2	OHMIC VALUE GANG N° 3	PACKAGING
	<b>B:</b> Bushing <b>S:</b> Servo	From 1 up to 6	10K	1K	20K	Box of 1 piece

## 1 1/16" (27 mm) Single Turn Conductive Plastic Precision Potentiometer

Vishay Spectrol

### DIMENSIONS in inches (millimeters)

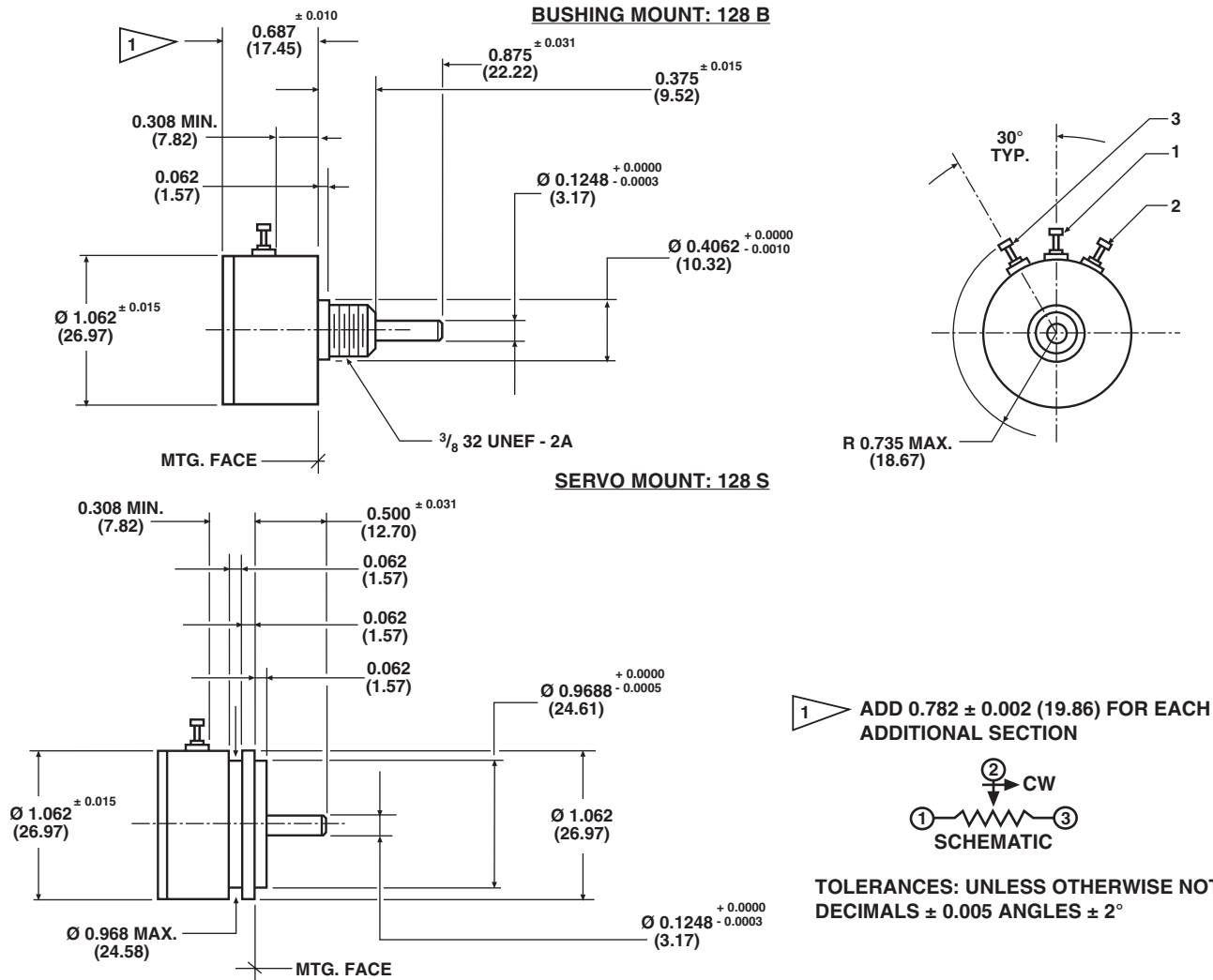

MECHANICAL SPECIFICATIONS		
PARAMETER		
Rotation	360° continuous	
Bearing Type	<b>SERVO MOUNT</b> Ball bearing	<b>BUSHING MOUNT</b> Sleeve bearing
Torque (Maximum) Servo, 1 Section Bushing, 1 Section Each Additional Section	<b>STARTING</b> 0.25 oz. - in (18.0 g - cm) 0.30 oz. - in (21.6 g - cm) 0.20 oz. - in (14.4 g - cm)	<b>RUNNING</b> 0.15 oz. - in (10.8 g - cm) 0.25 oz. - in (18.0 g - cm) 0.15 oz. - in (10.8 g - cm)
Mechanical Runouts (Maximum) Shaft Runout (TIR/in) Pilot Dia. Runout (TIR/in) Lateral Runout (TIR) Shaft End Play Shaft Radial Play	<b>SERVO</b> 0.002" (0.05 mm) 0.002" (0.05 mm) 0.002" (0.05 mm) 0.005" (0.13 mm) 0.002" (0.05 mm)	<b>BUSHING</b> 0.002" (0.05 mm) 0.002" (0.05 mm) 0.005" (0.13 mm) 0.005" (0.13 mm) 0.003" (0.08 mm)
Weight (Maximum): Single Section Each Additional Section	0.8 oz. (22.7 g) 0.4 oz. (11.3 g)	
Ganging	6 sections maximum, terminal alignment, added sections, within $\pm 10^\circ$ of section 1 terminals	
Moment of Inertia	0.12 g - cm <sup>2</sup> per section maximum	

# Model 128



Vishay Spectrol

1 1/16" (27 mm) Single Turn Conductive Plastic  
Precision Potentiometer

MATERIAL SPECIFICATIONS	
Housing and Lids	Aluminum, anodized
Shaft	Stainless steel, non-magnetic non-passivated
Terminals	Brass plated for solderability
Bushing Mount Hardware Lockwasher Internal Tooth, Panel Nut:	Steel, nickel plated Brass, nickel plated

ENVIRONMENTAL SPECIFICATIONS	
Vibration	15 g thru 2000 Hz
Shock	50 g
Salt Spray	96 h
Rotational Life	Servo: 20 million shaft revolutions Bushing: 5 million shaft revolutions
Load Life	900 h
Temperature Range	- 55 °C to + 125 °C

MECHANICAL SPECIFICATIONS	
Unit Identification	Units shall be marked with Vishay Spectrol name, model number and data code on each section, resistance, resistance tolerance, linearity and terminal identification

## POWER RATING CHART

(Ratings for cup No. 1.  
Additional cups 75 % of values shown)

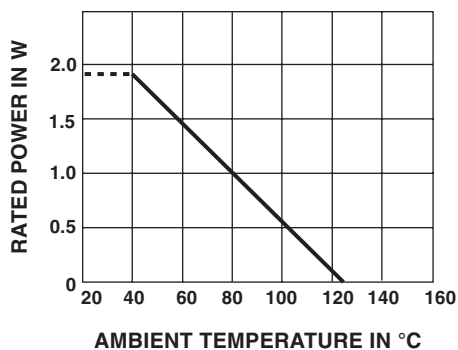

RESISTANCE ELEMENT DATA	
RESISTANCE VALUES (Ω)	MAXIMUM VOLTAGE APPLICABLE (V)
500	25
1K	35
2K	50
5K	79
10K	112
20K	158
50K	250

## 1 3/4" (44.5 mm) Single Turn Conductive Plastic Precision Potentiometer

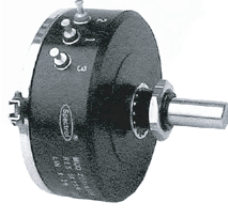

### FEATURES

- Rotational life exceeds 20 million shaft revolutions
- Virtually infinite resolution
- Designed for high reliability applications
- Co-molded track and multi-finger wiper provide low noise signal
- Bushing or servo types available up to 6 sections
- Ohmic value range: 500 Ω to 50 kΩ



<b>ELECTRICAL SPECIFICATIONS</b>		
PARAMETER		
Total Resistance Tolerance	<b>STANDARD</b> 500 Ω to 50 kΩ ± 10 %	<b>SPECIAL</b> - ± 5 %
Linearity (Independent)	<b>STANDARD</b> ± 0.3 %	<b>SPECIAL</b> ± 0.1 %
Electrical Angle	350° ± 3°	
Power Rating: Section 1: Additional Sections	1.75 W at 70 °C ambient derated to zero at 125 °C 75 % of the rating of section 1	
Output Smoothness	0.1 % maximum	
Insulation Resistance	1000 MΩ minimum, 500 V <sub>DC</sub>	
Dielectric Strength	1000 V <sub>RMS</sub> , 60 Hz	
Taps (Extra)	Extra taps available as special	
Phasing	Points at which output ratio is 0.5 aligned ± 1° (Ref. to section 1)	
Temperature Coefficient of Resistance	± 400 ppm/°C maximum	

<b>ORDERING INFORMATION/DESCRIPTION</b>				
The Model 208 can be ordered from this data sheet with a variety of alternate characteristics, as shown above. For most rapid service on your order, please state:				
<b>208</b>	<b>B</b>	<b>1</b>	<b>10K</b>	<b>B01</b>
MODEL	MOUNTING	NUMBER OF SECTIONS	TOTAL RESISTANCE OF EACH SECTION	PACKAGING
	<b>B:</b> Bushing <b>S:</b> Servo	Up to 6	Beginning with the section nearest the mounting end	Box of 1 piece
Other characteristics will be standard as described on this data sheet. If special characteristics are required, such as: special linearity tolerance, special resistance tolerance, extra taps, non-linear functions, etc., please state these on your order and allow additional lead time for delivery.				

<b>SAP PART NUMBERING GUIDELINES</b>					
<b>208</b>	<b>S</b>	<b>2</b>	<b>103</b>	<b>502</b>	<b>B01</b>
MODEL	STYLE	GANG NUMBERS	OHMIC VALUE GANG Nº 1	OHMIC VALUE GANG Nº 2	PACKAGING
	<b>B:</b> Bushing <b>S:</b> Servo	From 1 up to 6	10K	5K	



# Model 208



Vishay Spectrol 1 3/4" (44.5 mm) Single Turn Conductive Plastic Precision Potentiometer

## DIMENSIONS in inches (millimeters)

### SERVO MOUNT: 208 S

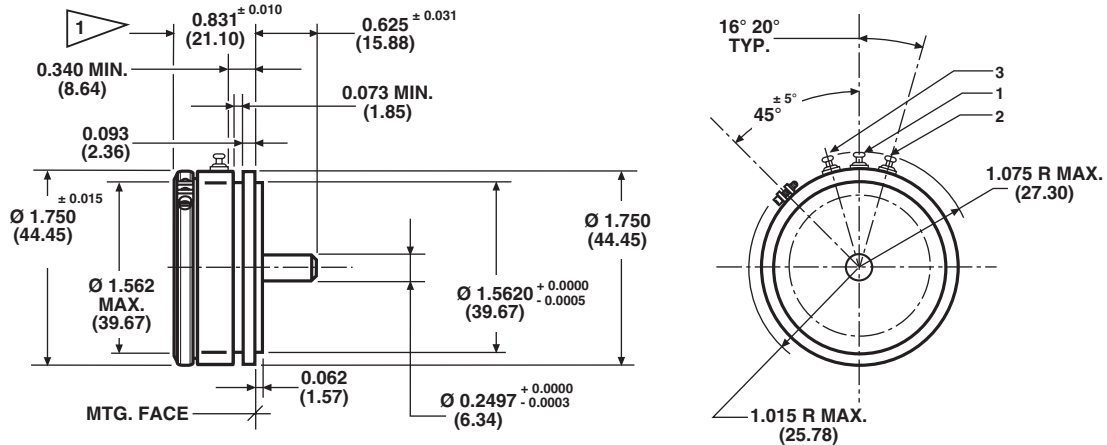

### BUSHING MOUNT: 208 B

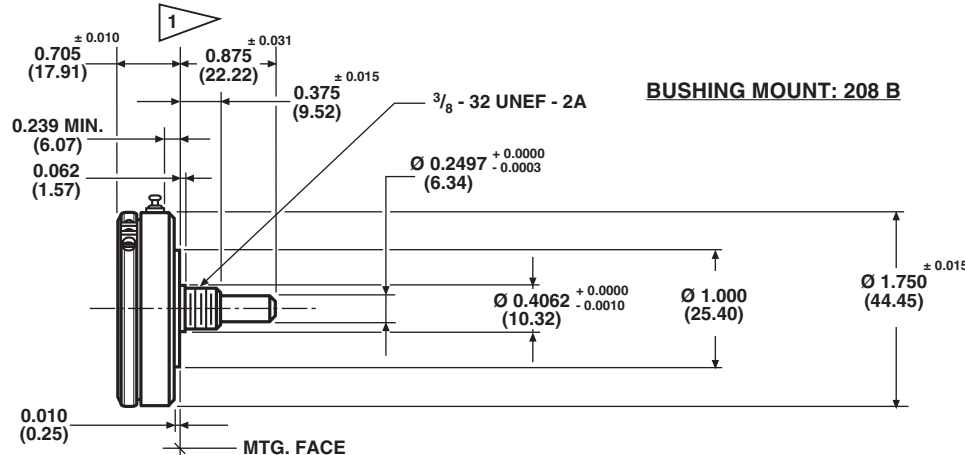

1 ADD 0.500 ± 0.002 (12.70) FOR EACH ADDITIONAL SECTION  
 TOLERANCES: UNLESS OTHERWISE NOTED.  
 DECIMALS ± 0.005 ANGLES ± 2°

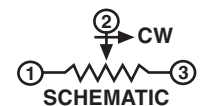

MECHANICAL SPECIFICATIONS		
PARAMETER		
Rotation	360° continuous	
Bearing Type	<b>SERVO MOUNT</b> Ball bearing	<b>BUSHING MOUNT</b> Sleeve bearing
Ganging	6 sections maximum terminal alignment, added sections within ± 10° of section 1 terminals	
Torque (Maximums)	<b>STARTING</b>	<b>RUNNING</b>
Servo Section 1	0.7 oz. - in (50.40 g - cm)	0.4 oz. - in (28.80 g - cm)
Bushing Section 1	1.0 oz. - in (72.0 g - cm)	0.7 oz. - in (50.40 g - cm)
Each Additional Section	0.4 oz. - in (28.80 g - cm)	0.3 oz. - in (21.60 g - cm)
Mechanical Runouts (Maximums):	<b>SERVO</b>	<b>BUSHING</b>
Shaft (TIR/in)	0.002" (0.05 cm)	0.002" (0.05 cm)
Pilot Dia. (TIR)	0.002" (0.05 cm)	0.002" (0.05 cm)
Lateral (TIR)	0.003" (0.08 cm)	0.005" (0.13 cm)
Shaft End Play	0.005" (0.13 cm)	0.005" (0.13 cm)
Shaft Radial Play	0.002" (0.05 cm)	0.003" (0.08 cm)
Moment of Inertia	1.0 g - cm <sup>2</sup> per section maximum	
Weight:		
Single Section	3.0 oz. (85.05 g)	
Each Additional Section	1.0 oz. (28.35 g)	



1 3/4" (44.5 mm) Single Turn Conductive Plastic Precision Potentiometer

Vishay Spectrol

MATERIAL SPECIFICATIONS	
Housing and Lids	Aluminium, anodized
Shaft and Clamp Rings	Stainless steel, non-magnetic non-passivated
Terminals	Brass, plated for solderability
Bushing Mount Hardware Lockwasher Internal Tooth: Panel Nut:	Steel, nickel plated Brass, nickel plated

MARKING	
Unit Identification	Units shall be marked with Spectrol name, model number and data code on each section, resistance, resistance tolerance, linearity and terminal identification

ENVIRONMENTAL SPECIFICATIONS	
Vibration	15 g thru 2000 Hz
Shock	50 g
Salt Spray	96 h
Rotational Life	Servo: 20 million shaft revolutions Bushing: 5 million shaft revolutions
Load Life	900 h
Operating Temperature Range	- 55 °C to + 125 °C

POWER RATING CHART

(Ratings for cup No.1. Additional cups 75 % of values shown)

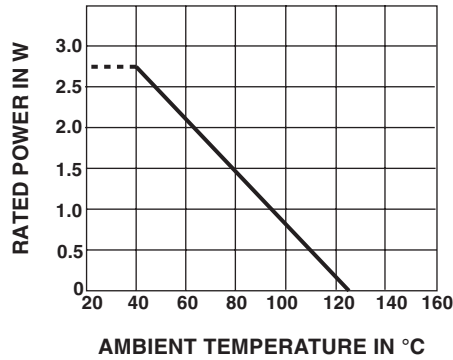

RESISTANCE ELEMENT DATA	
RESISTANCE VALUES (Ω)	MAXIMUM VOLTAGE APPLICABLE (V)
500	30
1K	42
2K	59
5K	94
10K	132
20K	187
50K	299

## 2" (50.8 mm) Single Turn Conductive Plastic Precision Potentiometer



**FEATURES**

- Bushing mount and servo mount types available
- Virtually infinite resolution
- Up to 6 sections available
- Rotational life exceeds 20 million shaft revolutions
- Co-Molded track and Multi-Finger wiper provide low noise signal
- Large ohmic value range: 500 Ω to 100 kΩ



ELECTRICAL SPECIFICATIONS		
PARAMETER		
Total Resistance Standard Range	500 Ω to 100 kΩ	
Tolerance	<b>STANDARD</b> ± 10 %	<b>SPECIAL</b> ± 5 %
Linearity (Independent)	<b>STANDARD</b> ± 0.25 %	<b>SPECIAL</b> ± 0.05 %
Electrical Angle	350° ± 2°	
Power Rating Section 1 Additional Sections	2.0 W at 70 °C ambient derated to zero at 125 °C (400 V <sub>DC</sub> maximum) 75 % of the rating of section 1	
Output Smoothness	0.1 % maximum	
Insulation Resistance	1000 MΩ minimum 500 V <sub>DC</sub>	
Dielectric Strength	1000 V <sub>RMS</sub> , 60 Hz	
Taps (Extra)	Extra taps available as special	
Phasing	Points at which output ratio is 0.5 aligned ± 1° (ref. to section 1)	
Temperature Coefficient of Resistance	± 400 ppm/°C maximum	

MATERIAL SPECIFICATIONS	
Housing and Lids	Aluminum, anodized
Shaft and Clamp Rings	Stainless steel, non-magnetic non-passivated
Terminals	Brass, gold plated for solderability
Bushing Mount Hardware Lockwasher Internal Tooth: Panel Nut:	Steel, nickel plated Brass, nickel plated

ENVIRONMENTAL SPECIFICATIONS	
Vibration	15 g thru 2000 Hz
Shock	50 g
Salt Spray	96 h
Rotational Life	Servo: 20 million shaft revolutions Bushing: 5 million shaft revolutions
Load Life	900 h
Temperature Range	- 55 °C to + 125 °C

ORDERING INFORMATION/DESCRIPTION				
The Model 308 can be ordered from this data sheet with a variety of alternate characteristics, as shown. For most rapid service on your order, please state:				
<b>308</b>	<b>B</b>	<b>1</b>	<b>20K</b>	<b>B01</b>
MODEL	MOUNTING	NUMBER OF SECTIONS	TOTAL RESISTANCE OF EACH SECTION	PACKAGING
	<b>B:</b> Bushing <b>S:</b> Servo	Up to 6	Beginning with the section nearest the mounting end	Box of 1 piece
Other characteristics will be standard as described on this data sheet. If special characteristics are required, such as: special linearity tolerance, special resistance tolerance, extra taps, non-linear functions, etc., please state these on your order and allow additional lead time for delivery.				

SAP PART NUMBERING GUIDELINES				
<b>308</b>	<b>S</b>	<b>1</b>	<b>203</b>	<b>B01</b>
MODEL	STYLE	GANG NUMBER	OHMIC VALUE GANG N° 1	PACKAGING
	<b>B:</b> Bushing <b>S:</b> Servo	From 1 up to 6	20K	



**DIMENSIONS** in inches (millimeters)

**SERVO MOUNT: 308 S**

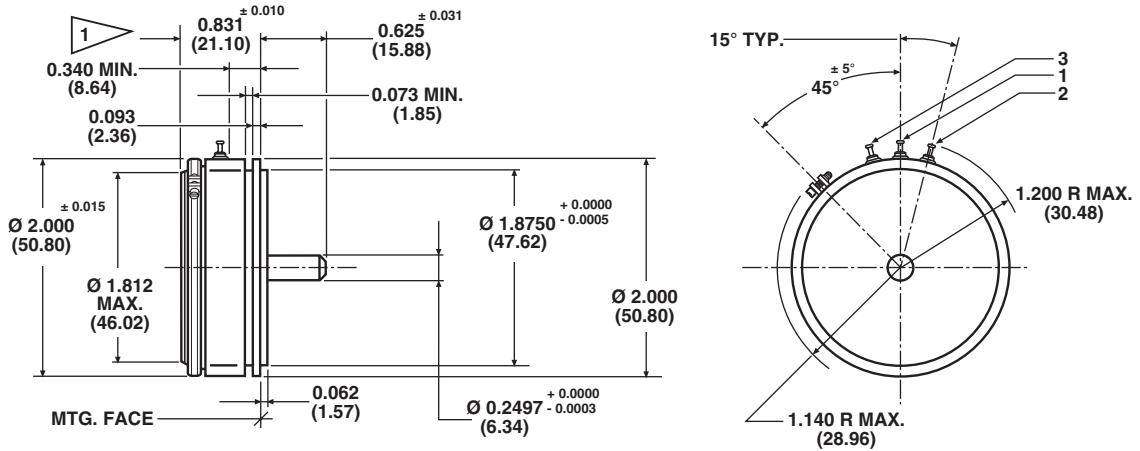

**BUSHING MOUNT: 308 B**

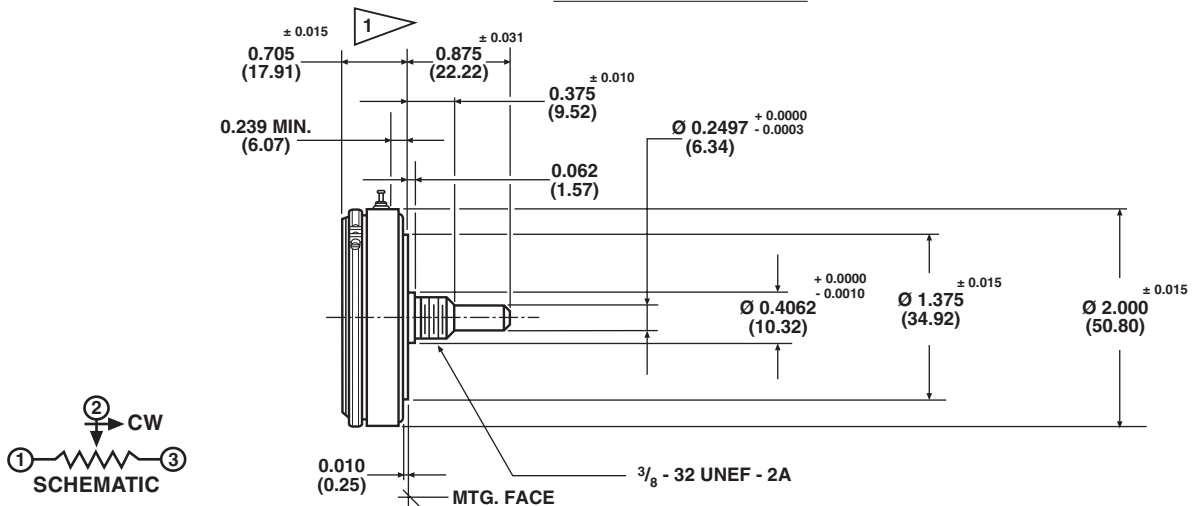

1 ADD 0.500 ± 0.002 (12.70) FOR EACH ADDITIONAL SECTION

TOLERANCES: UNLESS OTHERWISE NOTED. DECIMALS ± 0.005 ANGLES ± 2°

**POWER RATING CHART**

(Ratings for cup No. 1. Additional cups 75 % of values shown)

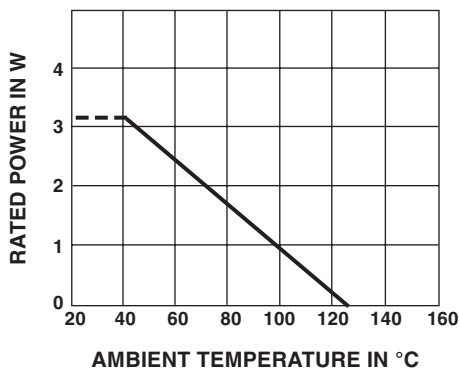

**RESISTANCE ELEMENT DATA**

RESISTANCE VALUES (Ω)	MAXIMUM VOLTAGE APPLICABLE (V)
500	32
1K	45
2K	71
5K	100
10K	141
20K	224
50K	316
100K	350*

\* Maximum voltage allowable

# Model 308



Vishay Spectrol

2" (50.8 mm) Single Turn Conductive Plastic  
Precision Potentiometer

<b>MECHANICAL SPECIFICATIONS</b>		
<b>PARAMETER</b>		
Rotation	360° (continuous)	
Bearing Type Servo Mount: Bushing Mount:	Ball bearing Sleeve bearing	
Ganging	6 sections maximum Terminal alignment, added sections, within $\pm 10^\circ$ of section 1 terminals	
Torque (Maximums) Mounting Servo, 1 Section Bushing, 1 Section Each Additional Section	<b>STARTING</b> 1.0 oz. - in (72.00 g - cm) 1.7 oz. - in (122.40 g - cm) 0.6 oz. - in (43.20 g - cm)	<b>RUNNING</b> 0.5 oz. - in (36.00 g - cm) 1.0 oz. - in (72.00 g - cm) 0.4 oz. - in (28.80 g - cm)
Runouts (Maximums) Shaft (TIR/in) Pilot Dia. (TIR) Lateral (TIR) Shaft End Play Shaft Radial Play	<b>SERVO</b> 0.002" (0.05 cm) 0.002" (0.05 cm) 0.003" (0.08 cm) 0.005" (0.13 cm) 0.002" (0.05 cm)	<b>BUSHING</b> 0.002" (0.05 cm) 0.002" (0.05 cm) 0.005" (0.13 cm) 0.005" (0.13 cm) 0.003" (0.08 cm)
Moment of Inertia	2.0 g - cm <sup>2</sup> per section maximum	
Weight Single Section Each Additional Section	4.0 oz. (127.57 g) 1.2 oz. (34.02 g)	

<b>MARKING</b>	
<b>Unit Identification</b>	Units shall be marked with Spectrol name, model no, and data code, and on each section, resistance, resistance tolerance, linearity and terminal identification

## 7/8" (22.2 mm) Single Turn Conductive Plastic Precision Potentiometer

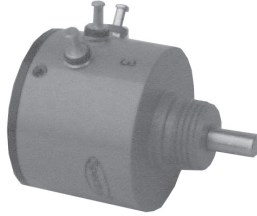

### FEATURES

- Virtually infinite resolution
- Bushing mount and servo mount types available
- Rotational life exceeds 20 million shaft revolutions
- Co-molded track and multi-finger wiper provide low noise signal
- Ohmic value range: 500 Ω to 50 kΩ



**RoHS**  
COMPLIANT

<b>ELECTRICAL SPECIFICATIONS</b>		
PARAMETER		
Total Resistance Standard Range:	500 Ω to 50 kΩ	
Tolerance:	<b>STANDARD</b> ± 10 %	<b>SPECIAL</b> ± 5 %
Linearity (Independent)	<b>STANDARD</b> ± 0.5 %	<b>SPECIAL</b> ± 0.2 %
Electrical Angle	340° ± 5°	
Power Rating Section 1: Additional Sections:	1.0 W at 70° ambient derated to zero at 125 °C 75 % of the rating of section 1	
Output Smoothness	0.1 % maximum	
Insulation Resistance	1000 MΩ minimum, 500 V <sub>DC</sub>	
Dielectric Strength	1000 V <sub>RMS</sub> , 60 Hz from Terminals to shaft	
Taps (Extra)	Extra taps available as special	
Phasing	Points at which output is 0.5 aligned ± 1° (ref. to section 1)	
Temperature Coefficient of Resistance	± 400 ppm/°C maximum	

<b>ORDERING INFORMATION/DESCRIPTION</b>				
The Model 708 can be ordered from this data sheet with a variety of alternate characteristics, as shown. For most rapid service on your order, please state:				
<b>708</b>	<b>B</b>	<b>1</b>	<b>10K</b>	<b>B01</b>
MODEL	MOUNTING	NUMBER OF SECTIONS	TOTAL RESISTANCE OF EACH SECTION	PACKAGING
	<b>B:</b> Bushing <b>S:</b> Servo	Up to 6	Beginning with the section nearest the mounting end	Box of 1 piece
Other characteristics will be standard as described on this data sheet. If special characteristics are required, such as: special linearity tolerance, special resistance tolerance, extra taps, non-linear functions, etc., please state these on your order and allow additional lead time for delivery.				

<b>SAP PART NUMBERING GUIDELINES</b>					
<b>708</b>	<b>S</b>	<b>2</b>	<b>102</b>	<b>103</b>	<b>B01</b>
MODEL	STYLE	GANGS	OHMIC VALUE GANG N° 1	OHMIC VALUE GANG N° 2	PACKAGING
	<b>B:</b> Bushing <b>S:</b> Servo	From 1 up to 6	1K	10K	

# Model 708



Vishay Spectrol

7/8" (22.2 mm) Single Turn Conductive Plastic Precision Potentiometer

## DIMENSIONS in inches (millimeters)

### BUSHING MOUNT: 708 B

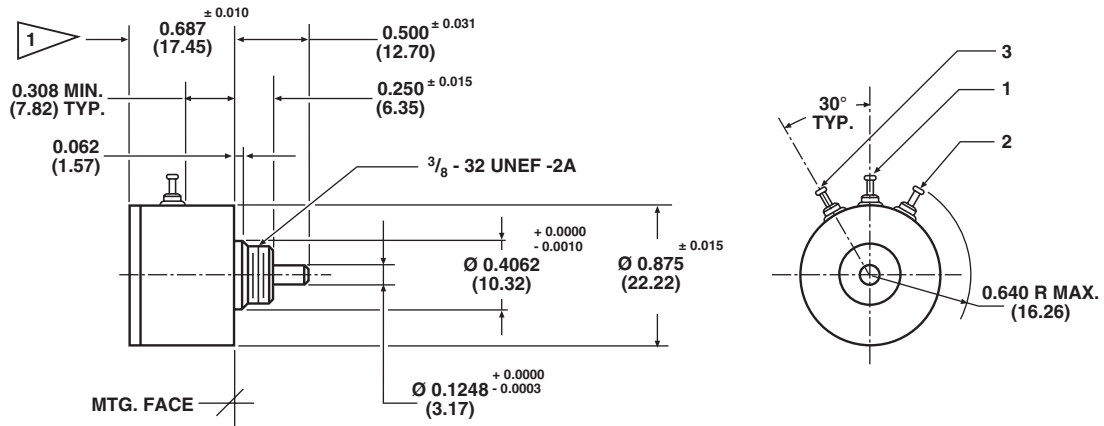

### SERVO MOUNT: 708 S

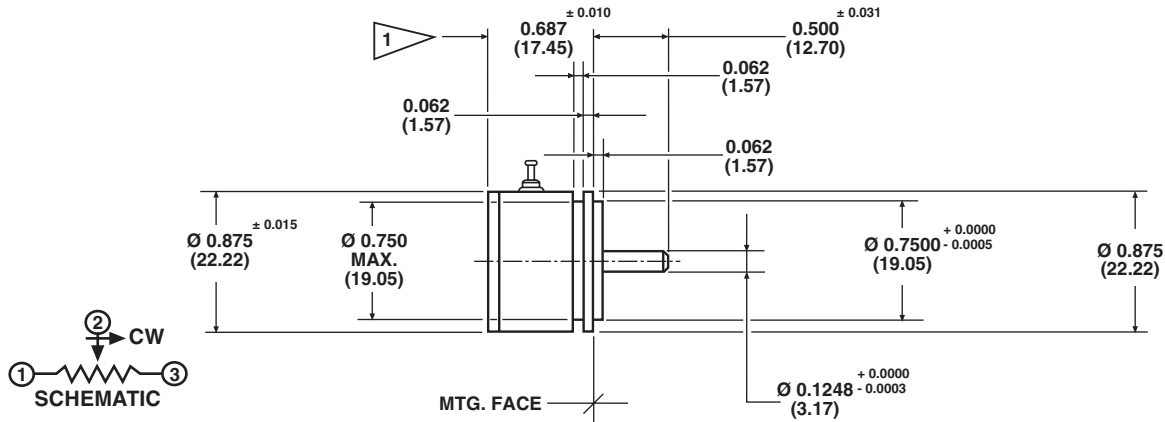

TOLERANCES: UNLESS OTHERWISE NOTED.  
DECIMALS ± 0.005 ANGLES ± 2°

1 ADD 0.500 ± 0.002 (12.70) FOR EACH ADDITIONAL SECTION

MECHANICAL SPECIFICATIONS		
PARAMETER		
Rotation	360° continuous	
Bearing Type Servo Mount: Bushing Mount:	Ball bearing Sleeve bearing	
Torque (Maximum) Servo, 1 Section Bushing, 1 Section Each Additional Section	<b>STARTING</b> 0.10 oz. - in (7.20 g - cm) 0.25 oz. - in (18.00 g - cm) 0.10 oz. - in (7.20 g - cm)	<b>RUNNING</b> 0.085 oz. - in (6.12 g - cm) 0.20 oz. - in (14.40 g - cm) 0.075 oz. - in (5.40 g - cm)
Runouts (Maximum) Shaft Runout (TIR/in) Pilot Dia. Runout (TIR) Lateral Runout (TIR) Shaft End Play Shaft Radial Play	<b>SERVO</b> 0.002" (0.05 cm) 0.002" (0.05 cm) 0.002" (0.05 cm) 0.005" (0.13 cm) 0.002" (0.05 cm)	<b>BUSHING</b> 0.002" (0.05 cm) 0.002" (0.05 cm) 0.005" (0.13 cm) 0.005" (0.13 cm) 0.004" (0.10 cm)
Weight (Maximum) Single Section: Each Additional Section:	0.6 oz. (17.0 g) 0.2 oz. (5.67 g)	
Ganging	6 sections max, terminal alignment, added sections within ± 10° of section 1 terminals	
Moment of Inertia	0.12 g - cm <sup>2</sup> per section maximum	



7/8" (22.2 mm) Single Turn Conductive Plastic Precision Potentiometer

Vishay Spectrol

MATERIAL SPECIFICATIONS	
Housing and Lids	Aluminum, anodized
Shaft	Stainless steel, non-magnetic non-passivated
Terminals	Brass plated for solderability
Bushing Mount Hardware Lockwasher Internal tooth: Panel Nut:	Steel, nickel plated Brass, nickel plated

ENVIRONMENTAL SPECIFICATIONS	
Vibration	15 g thru 2000 Hz
Shock	50 g
Salt Spray	96 h
Rotational Life	Servo: 20 million shaft revolutions Bushing: 5 million shaft revolutions
Load Life	900 h
Temperature Range	- 55 °C to + 125 °C

MARKING	
Unit Identification	Units shall be marked with Spectrol name, model no, and data code, and on each section, resistance, resistance tolerance, linearity and terminal identification

POWER RATING CHART

(Ratings for cup No. 1.  
Additional cups 75 % of values shown)

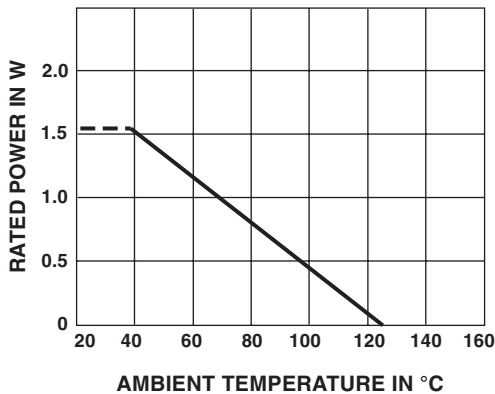

RESISTANCE ELEMENT DATA	
RESISTANCE VALUES (Ω)	MAXIMUM VOLTAGE APPLICABLE (V)
500	22
1K	32
2K	45
5K	71
10K	100
20K	141
50K	224



## Precision Rotative Transducers, Conductive Plastic, Bushing Mounting



A complete range of bushing mounting rotational motion transducers.

### FEATURES

- Size 08 to 30
- Linearity  $\pm 1\%$  down to  $\pm 0.05\%$
- Good repeatability
- Long life
- Essentially infinite resolution
- Up to 6 electrical functions with the same shaft
- On request custom design to meet your specifications
- Following MIL-R-39023 and NFC 93-255 requirements



SIZE	08	09	11	13	15	18	20	30
MODEL	34 BF	78 BF	116 BF	156 BF	176 BF	134 BF	200 BF	300 BF

ELECTRICAL SPECIFICATIONS								
Functions	Linear, on request specific law							
Theoretical Electrical Angle (TEA)	Actual electrical angle (AEA) - $2^\circ$							
Independent Linearity (over TEA) Best Linearity Available	$A \leq \pm 1\%$		or	$B \leq \pm 0.5\%$		or	$C \leq \pm 0.25\%$	
	$C \leq \pm 0.25\%$		Down to $D \leq \pm 0.1\%$			Down to $E \leq \pm 0.05\%$		
Actual Electrical Angle (AEA)	$340^\circ \pm 3^\circ$			$350^\circ \pm 2^\circ$				
Ohmic Values ( $R_T$ )	1 k $\Omega$ - 2 k $\Omega$ - 5 k $\Omega$ - 10 k $\Omega$ - on request other values							
Ohmic Value Tolerances at 20 °C	$\pm 10\%$							
Output Smoothness	$\leq 0.05\%$					$\leq 0.025\%$		
Maximum Power Rating at 70 °C	0.25 W	0.3 W	0.4 W	0.5 W	0.75 W	1.0 W	1.2 W	1.5 W
Wiper Current	Recommended: a few $\mu$ A - 1 mA max. (continuous)							
Tap (Current or Voltage) On Request with Angular Position to be Specified	U = current		{ Position: $\pm 2^\circ$ { Width: $\leq 4^\circ$		/ T = voltage			Position: $\pm 2^\circ$
Load Resistance on Wiper ( $R_L$ )	min. $10^3 \times R_T$							
Repeatability	$\leq 0.02\%$							
End Voltage	$\leq 0.4\%$ for $470 \Omega \leq R_T \leq 1000 \Omega$ / $\leq 0.2\%$ for $1000 \Omega < R_T \leq 2200 \Omega$ / $\leq 0.1\%$ for $R_T > 2200 \Omega$							
Insulation Resistance	$\geq 1000 \text{ M}\Omega$ , 500 V <sub>DC</sub>							
Dielectric Strength	$\geq 750 \text{ V}_{\text{RMS}}$ , 50 Hz				$\geq 1000 \text{ V}_{\text{RMS}}$ , 50 Hz			

MECHANICAL SPECIFICATIONS									
Mechanical Rotation	360° continuous; stops on request								
Mounting Type	Bushing								
Shaft Guiding	Sleeve bearings; on request ball bearings								
Shaft	Stainless steel								
Housing	Plastic moulding; on request anodized aluminum								
Termination	Turrets; on request flexible leads, cables...								
Wiper	Precious metal multi-finger contact								
Starting Torque (N.cm)	$\leq 0.5$ 1 cup; $\leq 0.3$ for each additional cup								
Moment of Inertia (g. cm <sup>2</sup> )	0.3	0.4	0.6	0.8	2.2	2.8	3.5	10	
	1 cup	11 $\pm$ 2	20 $\pm$ 2	21 $\pm$ 2	30 $\pm$ 2	33 $\pm$ 2	45 $\pm$ 3	54 $\pm$ 3	120 $\pm$ 10
Weight (g)	each additional cup	5 $\pm$ 2	6 $\pm$ 2	7 $\pm$ 2	14 $\pm$ 2	16 $\pm$ 2	18 $\pm$ 3	21 $\pm$ 3	62 $\pm$ 10

PERFORMANCE	
Life (Million of Cycles)	$\geq 20$
Temperature Range	- 55 °C to + 125 °C
Climatic Category	55/125/04
Rotation Speed (RPM)	150

**DIMENSIONS** in millimeters, general tolerance  $\pm 0.5$  mm

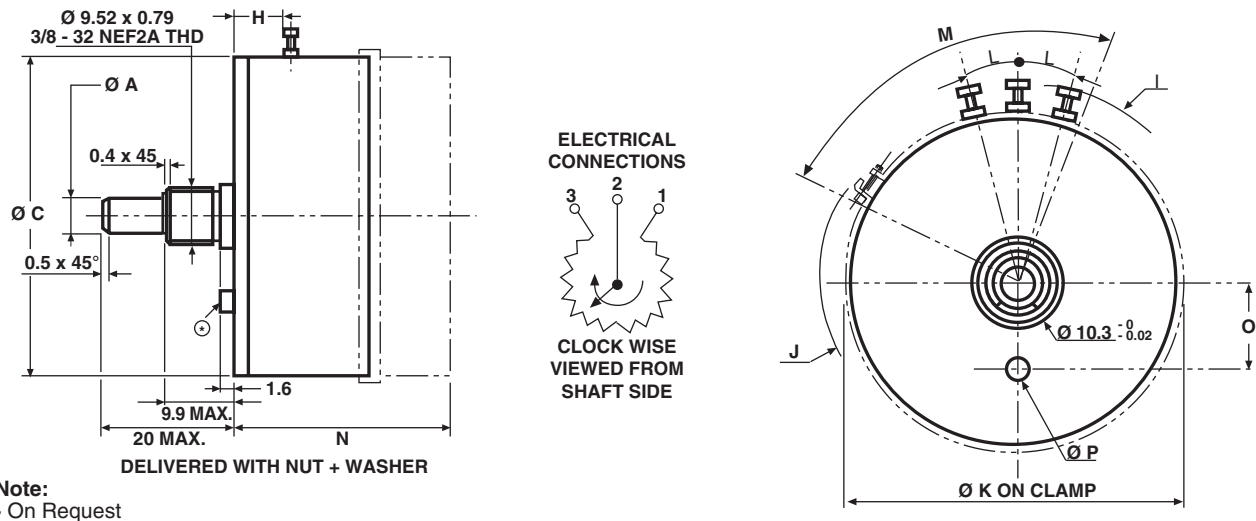

Note:  
• On Request

DIMENSIONS	DESIGNATION	SIZE	POTENTIOMETER REFERENCE							
			08	09	11	13	15	18	20	30
		MODEL	34 BF	78 BF	116 BF	156 BF	176 BF	134 BF	200 BF	300 BF
A - 0 - 0.013	Ø shaft		3.175	3.175	3.175	3.175	6.345	6.345	6.345	6.345
C max.	Ø body		19.18	22.3	27.07	33.35	36.6	44.5	50.9	76.4
H min.	Turret location		4.2	4.7	5.35	5.35	8	8	7.45	5.55
I max.	Radius on turrets		14	15.4	17.3	20.8	23.1	26.6	29.7	43.7
J max.	Radius on screw clamp		13.5	15.4	17.3	18.9	23.1	26.5	29.3	42.6
K	Ø on clamp		19.6	23.8	27.7	33.6	37.4	44.5	50.8	77.5
O	Locating pin (on request)		7.2	8	8.8	9	14.4	16.8	13.48	-
P max.	Ø pin (on request)		1.6	1.6	3.25	3.25	3.25	3.25	-	-
$L \pm 2^\circ$	Angle between turrets		$30^\circ$	$30^\circ$	$25^\circ$	$20^\circ$	$20^\circ$	$25^\circ$	$15^\circ$	$15^\circ$
M max.	Total angle		$100^\circ$	$100^\circ$	$100^\circ$	$100^\circ$	$80^\circ$	$80^\circ$	$80^\circ$	$80^\circ$
N max.	1 cup		14.5	19	19	19	21	21	21	20.5
	2 cups		21.5	25	21.5	24	24.5	24.5	26	23.5
	3 cups		34.5	38	34.5	38	37.5	37.5	38	-
	4 cups		40.5	48	40.5	45.5	48	48	48	-
	5 cups		53	61	53	59	60.5	61	62	-
	6 cups		59	72	59	67	72	72	72	-

**ORDERING INFORMATION/DESCRIPTION**

ROT	156	B	F	1	C	T	502	e1
SERIES	SIZE	MOUNTING TYPE	CONDUCTOR	NUMBER OF CUPS	LINEARITY	TAP	OHMIC VALUE	LEAD FINISH
		B: Bushing	F: Plastic film	From 1 up to 6	A: $\pm 1\%$ B: $\pm 0.5\%$ C: $\pm 0.25\%$ D: $\pm 0.1\%$ E: $\pm 0.05\%$	On request T: Voltage U: Current position to be specified	First 2 digits are significant numbers 3rd digit indicates number of zeros	

Special characteristics and designs on request

**SAP PART NUMBERING GUIDELINES**

RO 116BF	1	D	103
MODEL	GANG NUMBER	LINEARITY	OHMIC VALUE
	From 1 up to 6		10 kΩ

## Precision Rotative Transducers, Conductive Plastic, Servo Mounting

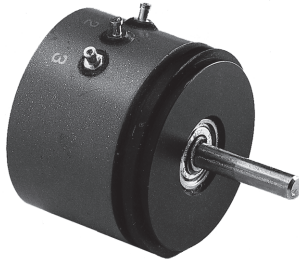

A complete range of servo mounting rotational transducers for applications requiring long life accuracy and speed.

### FEATURES

- Size 08 to 30
- Linearity  $\pm 1\%$  down to  $\pm 0.015\%$
- Excellent repeatability
- Long life
- Essentially infinite resolution
- Up to 6 electrical functions with the same shaft
- On request custom design to meet your specifications
- Following MIL-R-39023 and NFC 93-255 requirements



SIZE	08	09	11	13	15	18	20	30
MODEL	34 SF	78 SF	116 SF	156 SF	176 SF	134 SF	200 SF	300 SF

ELECTRICAL SPECIFICATIONS								
Functions	Linear, on request specific law							
Theoretical Electrical Angle (TEA)	TEA = actual electrical angle (AEA) - 2°							
Independent Linearity (over TEA) On Request Best Linearity Available	A $\leq \pm 1\%$ or B $\leq \pm 0.5\%$ or C $\leq \pm 0.25\%$ or D $\leq \pm 0.1\%$ D $\leq \pm 0.1\%$ Down to E $\leq \pm 0.05\%$ Down to F $\leq \pm 0.025\%$ Down to $\leq \pm 0.015\%$							
Actual Electrical Angle (AEA)	340° $\pm 3^\circ$				350° $\pm 2^\circ$			
Ohmic Values (R <sub>T</sub> )	1 k $\Omega$ - 2 k $\Omega$ - 5 k $\Omega$ - 10 k $\Omega$ - on request other values							
Ohmic Value Tolerances at 20 °C	$\pm 10\%$ ; on request $\pm 5\%$							
Output Smoothness	$\leq 0.025\%$						On request $\leq 0.01\%$	
Maximum Power Rating at 70 °C	0.25 W	0.3 W	0.4 W	0.5 W	0.75 W	1.0 W	1.2 W	1.5 W
Wiper Current/Load Resistance	Recommended: a few $\mu\text{A}$ - 1 mA max. continuous/minimum $10^3 \times R_T$							
Tap (Current or Voltage) On Request with Angular Position to be Specified	U = Current		{ Position: $\pm 2^\circ$ { Width: $\leq 4^\circ$		/ T = Voltage		Position: $\pm 2^\circ$	
Repeatability	$\leq 0.01\%$							
End Voltage	$\leq 0.4\%$ for $470 \Omega \leq R_T \leq 1000 \Omega$ / $\leq 0.2\%$ for $1000 \Omega \leq R_T \leq 2200 \Omega$ / $\leq 0.1\%$ $R_T > 2200 \Omega$							
Insulation Resistance	$\geq 1000 \text{ M}\Omega$ , 500 V <sub>DC</sub>							
Dielectric Strength	$\geq 750 \text{ V}_{\text{RMS}}$ , 50 Hz				$\geq 1000 \text{ V}_{\text{RMS}}$ , 50 Hz			

MECHANICAL SPECIFICATIONS									
Mechanical Rotation	360° continuous; stops on request								
Mounting/Shaft Guiding	Servo/ball bearings								
Housing	Diallylphthalate; on request anodized aluminum								
Termination	Turrets; on request flexible leads, cables...								
Wiper	Precious metal multi-finger contact								
Starting Torque (N.cm)	1 cup	0.2				0.25			
	each additional cup	0.15							
Moment of Inertia (g. cm <sup>2</sup> )		0.3	0.4	0.6	0.8	2.2	2.8	3.5	10
Weight (g)	1 cup	11 $\pm 2$	16 $\pm 2$	20 $\pm 2$	29 $\pm 2$	49 $\pm 2$	67 $\pm 3$	79 $\pm 3$	120 $\pm 10$
	each additional cup	5 $\pm 2$	6 $\pm 2$	7 $\pm 2$	10 $\pm 2$	16 $\pm 2$	18 $\pm 3$	21 $\pm 3$	62 $\pm 10$

PERFORMANCE	
Life (Million of Cycles)	$\geq 50$
Temperature Range	- 55 °C to + 125 °C
Climatic Category	55/125/04
Maximum Rotation Speed (RPM)	600
Sine Vibration on 3 Axes	1.5 mm or 20 g from 10 Hz to 2000 Hz
Mechanical Shocks on 3 Axes	50 g - 11 ms - half sine

#### DIMENSIONS in millimeters, general tolerance $\pm 0.5$ mm

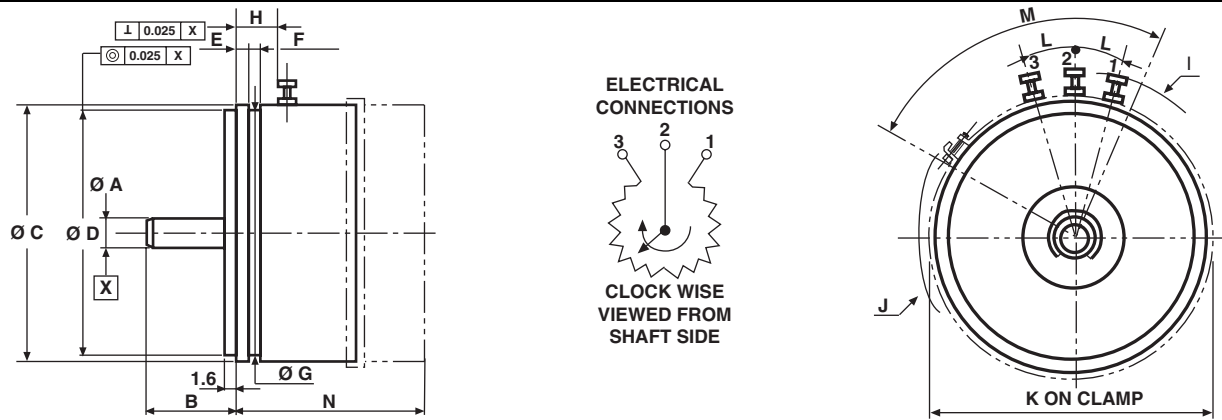

DIMENSIONS	DESIGNATION	SIZE	POTENTIOMETER REFERENCE							
			08	09	11	13	15	18	20	30
		MODEL	34 SF	78 SF	116 SF	156 SF	176 SF	134 SF	200 SF	300 SF
A - 0 - 0.013	$\varnothing$ shaft stainless steel		3.175	3.175	3.175	3.175	6.345	6.345	6.345	6.345
B max.	Shaft length		13	16.6	16.6	16.6	16.6	16.6	16.6	16.6
C max.	$\varnothing$ body plastic molded		19.18	22.3	27.07	33.35	36.6	44.5	50.9	76.3
D	$\varnothing$ flange		15.875	19.05	24.608	30.16	33.337	39.674	47.625	73.025
	Tolerance on flange		+ 0 - 13 $\mu$ m						+ 0 - 25 $\mu$ m	
E	Shoulder		1.6	1.6	1.6	1.6	1.6	1.6	2.4	2.4
F min.	Width of groove		1.5	1.5	1.5	1.5	2.2	1.8	2.2	1.75
$\varnothing$ G max.	Diameter of groove		17.57	19.8	24.8	30.9	33.3	41.4	47.6	73.1
H min.	Turret location		5.8	5.95	6.3	6.3	7	10.15	10.2	10.2
I max.	Radius on turrets		14	15.4	17.3	20.5	23.1	26.5	29.7	43.7
J max.	Radius on screw clamp		13.5	15.4	17.3	18.9	23.1	26.5	29.7	42.6
K max.	$\varnothing$ on clamp		19.6	23.8	27.7	33.6	37.4	44.5	50.8	77.5
L $\pm 2^\circ$	Angle between turrets		30°	30°	25°	20°	20°	25°	15°	15°
M max.	Total angle		100°	100°	100°	100°	80°	80°	80°	80°
N max.	1 cup		16	20.5	20.5	20.5	23.5	23.5	23.5	23
	2 cups		23	27	23	25.5	26.13	26	28.5	34.5
	3 cups		36	40	36	39.5	39.5	39.5	40.97	-
	4 cups		42	50	42	47	49.5	49.5	50.72	-
	5 cups		54.5	63	54	60.5	62.5	62.5	64.5	-
	6 cups		60.5	74	60.5	68.5	73.5	73.5	74.5	-

#### ORDERING INFORMATION/DESCRIPTION

ROT	156	S	F	1	C	T	502	e1
SERIES	MODEL	MOUNTING TYPE	CONDUCTOR	NUMBER OF CUPS	LINEARITY	TAP	OHMIC VALUE	LEAD FINISH
		S: Servo	F: Plastic Film	From 1 up to 6	Code A: $\pm 1\%$ B: $\pm 0.5\%$ C: $\pm 0.25\%$ D: $\pm 0.1\%$ E: $\pm 0.05\%$ F: $\pm 0.025\%$	On request T: Voltage U: Current position to be specified	First 2 digits are significant numbers 3rd digit indicates number of zeros	

Special characteristics designs on request

#### SAP PART NUMBERING GUIDELINES

RO 116SF	1	D	502
MODEL	GANG NUMBER	LINEARITY	OHMIC VALUE
	From 1 up to 6		5 k $\Omega$

## Precision Rotative Transducers 360° Special Laws: Sine/Cosine

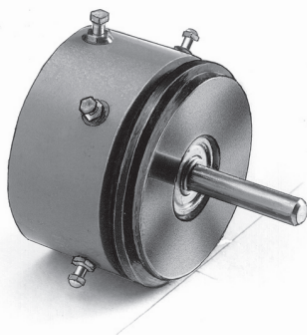

Rotational motion transducers with trigonometric laws for a full angle measurement: 360° (no dead band).

### FEATURES

- Laws: sine and cosine
- Size 11
- Continuous measure on 360°
- Long life up to 25 10<sup>6</sup> cycles
- Conformity from ± 1 % down to ± 0.5 %
- Bushing or servo mounting
- Following MIL-R-39023 requirements



<b>SIZE</b>	11	
<b>MODEL</b>	116 SFZ	116 BFZ
<b>LAW</b>	Z: Sine and cosine	

ELECTRICAL SPECIFICATIONS	
Theoretical Electrical Angle (TEA) = 360°	Actual electrical angle (AEA) = TEA
Conformity Peak to Peak	A ≤ ± 1 % or B ≤ ± 0.5 %
Number of Cups	Up to 2
Ohmic Values (R <sub>T</sub> per Quadrant)	1 kΩ - 5 kΩ - 10 kΩ - on request other values
Ohmic Value Tolerances at 20 °C	± 20 %
Output Smoothness	≤ 0.05 %
Maximum Power Rating at 70 °C	0.4 W
Wiper Current	Recommended: a few μA - 1 mA max. (continuous)
Ground Taps	On request
Resistance Load on Wiper	Minimum 10 <sup>3</sup> x R <sub>T</sub>
Resolution	Essentially infinite
Insulation Resistance	≥ 1000 MΩ, 500 V <sub>DC</sub>
Dielectric Strength	≥ 500 V <sub>RMS</sub> , 50 Hz

MECHANICAL SPECIFICATIONS	
Mechanical Angle (MA)	360° continuous
Mounting Type	Servo Bushing
Shaft Guiding	Ball bearings Sleeve bearings
Shaft	Stainless steel
Housing	Plastic moulding
Termination	Turrets
Wiper	Precious metal multi-finger contact
Starting Torque (N.cm)	1 cup ≤ 0.3
	2 cups ≤ 0.5
Weight (g)	≤ 0.8
	30 ± 2 (1 cup) + 17 ± 2 (2 cups)



<b>PERFORMANCE</b>		
Life (10 <sup>6</sup> Cycles)	≥ 25 (servo)	≥ 15 (bushing)
Temperature Range	- 55 °C to + 125 °C	
Climatic Category	55/125/04	
Speed Rotation (RPM)	600 (servo)	150 (bushing)
Sine Vibration on 3 Axes	1.5 mm or 20 g from 10 Hz to 2000 Hz	
Mechanical Shocks on 3 Axes	50 g - 11 ms - half sine	

**TRIGONOMETRIC FUNCTIONS**

SINE/COSINE OVER 360°

LAW Z

$$\frac{e_s}{E} = \sin \alpha \quad \frac{e_c}{E} = \cos \beta$$

$$0^\circ \leq \Theta \leq 360^\circ$$

$$\beta = \alpha + 90^\circ$$

**DIMENSIONS** in millimeters, general tolerance ± 0.5 mm

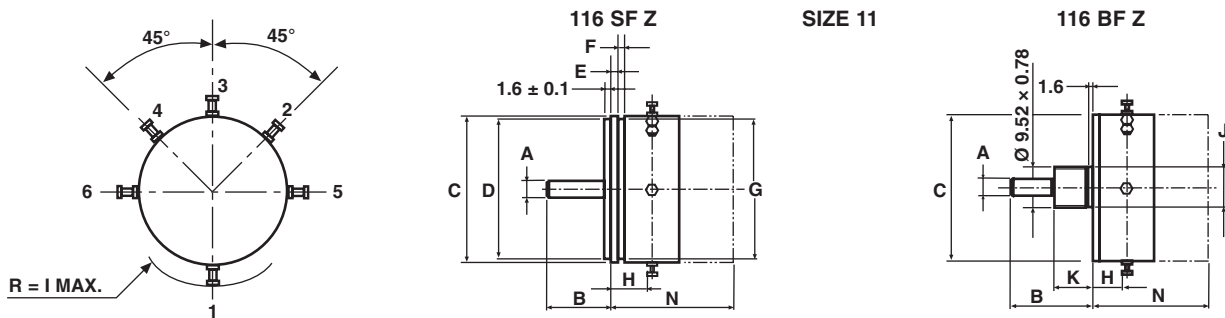

- 1: POWER SUPPLY (+)
- 2: POWER SUPPLY (-)
- 3: WIPER (SINE)
- 4: WIPER (COSINE)
- 5: GROUND TAP (ON REQUEST)
- 6: GROUND TAP (ON REQUEST)

DIMENSIONS mm	A	B	C	D	E	F	G	H	I	J	K	N max. (1 cup)	N max. (2 cups)
	+0 -0.013	max.	max.	+0 -0.013	± 0.1	min.	max.	min.	max.	+0 -0.02	max.		
DESIGNATION													
116 SF Z	3.175	16.6	27.05	24.608	1.6	1.5	24.8	4.5	17.3	-	-	18.5	35
116 BF Z		20	27.05	-	-	-	-	3	-	10.3	9.6	16.5	33

**ORDERING INFORMATION/DESCRIPTION**

ROT	116	S	F	Z	1	A	502	e1
SERIES	MODEL	MOUNTING TYPE	CONDUCTOR	LAW	NUMBER OF CUPS	CONFORMITY	OHMIC VALUE	LEAD FINISH
		S: Servo B: Bushing	F: Plastic	Z: Sine/cosine	2 max.	A: ± 1 % B: ± 0.5 %	First 2 digits are significant numbers 3rd digit indicates number of zeros	

Special characteristics and designs on request

**SAP PART NUMBERING GUIDELINES**

RO 116SFZ	1	B	103
MODEL	GANG NUMBER	CONFORMITY	OHMIC VALUE
	1 or 2	A or B	10 kΩ





# Plastic Film Technology

## Linear



### Contents

#### Industrial Models

Series REC 10 LA .....	52
Series REC 10 LH .....	54
Series REC 16 LA .....	56
Series REC 16 LH .....	59
Series REC 110 L .....	61
Series REC 115 L .....	65
Series REC 139 L .....	67
Series KIT LMF .....	69

#### Professional Models

Series REC 34 L .....	71
Series REC 38 L .....	74
Series REC 50 L .....	76



## Precision Linear Transducers, Designed for Mounting in Hydraulic or Pneumatic Cylinder, Conductive Plastic (Sealed Series/Ø 10 mm)



### FEATURES

- Large range of strokes from 25 to 500 mm
- High accuracy
- Very good repeatability
- Continuous resolution
- Easy mounting



This sensor is to be installed in the high pressure chamber of small cylinders and is equipped with glass-sealed electrical outputs.

ELECTRICAL SPECIFICATIONS	
Theoretical Electrical Travel (TET) = E	From 25 mm to 500 mm in increments of 25 mm
Independent Linearity (over TET) On Request	$\leq \pm 1\%$ ; $\leq \pm 0.1\%$ $\leq \pm 0.05\%$ if $E \geq 100$ mm $\leq \pm 0.025\%$ if $E \geq 200$ mm
Actual Electrical Travel (AET)	TET + 6 mm $\pm$ 0.5
Total Resistance $R_T$	150 $\Omega$ /cm
Resistance Tolerance at 20 °C	$\pm 20\%$
Repeatability	$\leq 0.01\%$
Maximum Power Rating	0.05 W/cm at 70 °C, 0 W at 125 °C
Wiper Current	Recommended: a few $\mu$ A - 1 mA max. (continuous)
Load Resistance	1000 times $R_T$ minimum
Insulation Resistance	> 1000 M $\Omega$ , 500 V <sub>DC</sub>
Dielectric Strength	> 300 V <sub>RMS</sub> at 50 Hz

MECHANICAL SPECIFICATIONS	
Mechanical Travel (MT)	MT = TET
Body	Anodized aluminum
Rod Internal Diameter	Ø 12 mm
Support	Stainless steel
Operating Force	1 N typical
Sealing	Glass-sealing on electrical outputs
Electrical Outputs	Wires AWG 26 L = 300 mm
Oil	Insulating mineral hydraulic
Pressure	300 bars continuous, 1000 bars accidentally
Wiper	Precious metal multifinger

PERFORMANCE	
Life	25 million cycles typical/1 Hz/T° = 20 °C $\pm$ 5 °C/80 % TET
Temperature Limits	- 20 °C to + 80 °C
Speed at 20 °C	1.5 m/s max.



Precision Linear Transducers, Designed for Mounting  
in Hydraulic or Pneumatic Cylinder, Conductive Plastic  
(Sealed Series/Ø 10 mm)

Vishay Sfernice

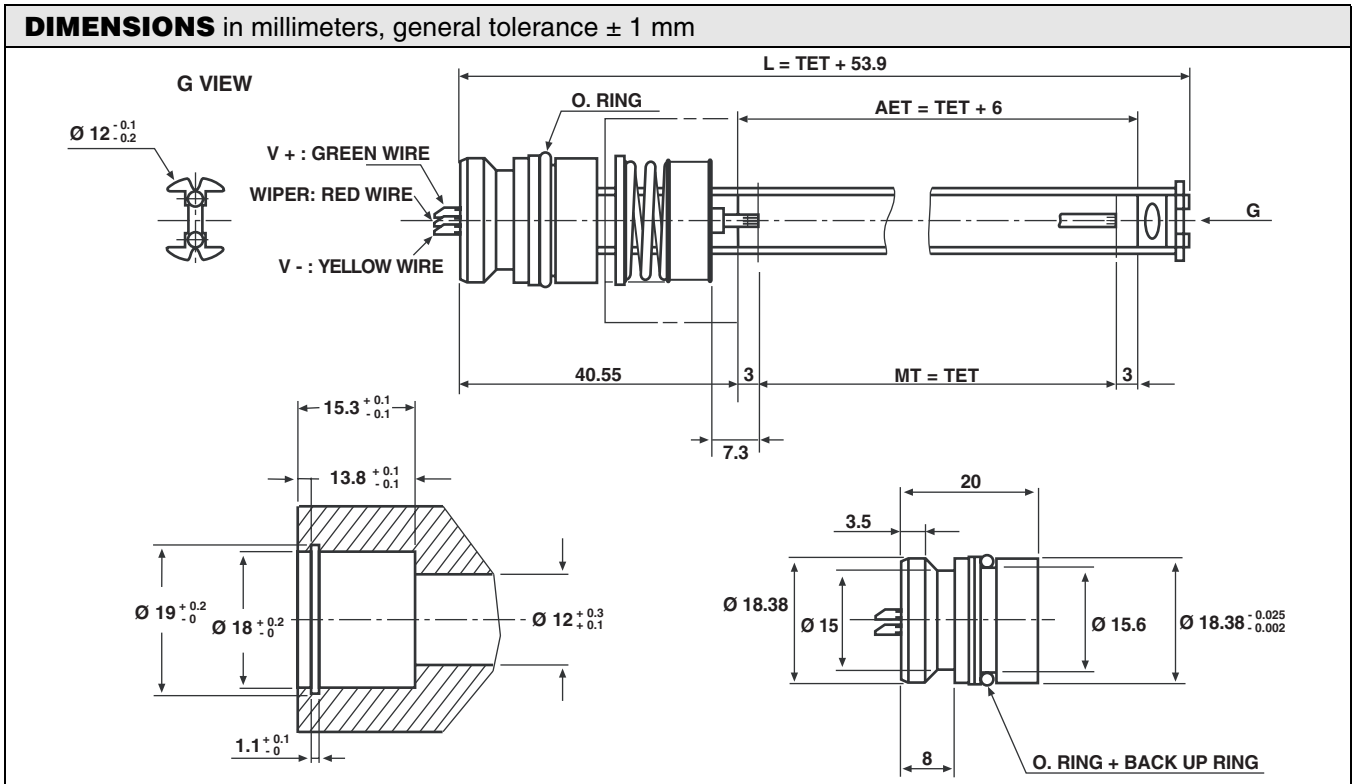

General Tolerance:  $\pm 1$  mm

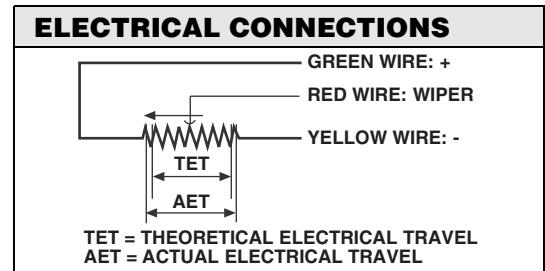
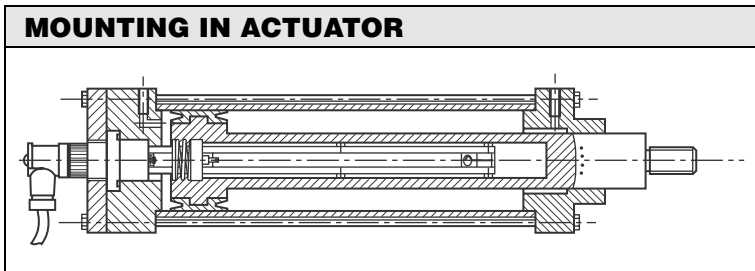

**ORDERING INFORMATION/DESCRIPTION**

REC	10	LA	4	D	152	W...	e.
SERIES	MODEL	TYPE	THEORETICAL ELECTRICAL	LINEARITY	RESISTANCE	MODIFICATIONS	LEAD FINISH
		Sealed	Times 25 mm	A: $\leq \pm 1\%$ D: $\leq \pm 0.1\%$ E: $\leq \pm 0.05\%$ F: $\leq \pm 0.025\%$	First 2 digits are significant numbers 3rd digit indicates number of zeros	Special feature code number	

**SAP PART NUMBERING GUIDELINES**

RE	10 LA	4	D	152	W...
SERIES	MODEL	TET	LINEARITY	OHMIC VALUE	SPECIAL FEATURES

## Precision Linear Transducers, Designed for Mounting in Hydraulic or Pneumatic Cylinder, Conductive Plastic Element (Unsealed Series/Ø 10 mm)



### FEATURES

- Large range of strokes from 25 to 500 mm
- High accuracy
- Very good repeatability
- Continuous resolution
- Easy mounting



These unsealed sensors are suitable for installation in the high pressure chamber of cylinders.

ELECTRICAL SPECIFICATIONS	
Theoretical Electrical Travel (TET) = E	From 25 mm to 500 mm in increments of 25 mm
Independent Linearity (over TET) On Request	$\leq \pm 1\%$ ; $\leq \pm 0.1\%$ $\leq \pm 0.05\%$ if $E \geq 100$ mm $\leq \pm 0.025\%$ if $E \geq 200$ mm
Actual Electrical Travel (AET)	TET + 6 mm $\pm$ 0.5
Total Resistance $R_T$	150 $\Omega$ /cm
Resistance Tolerance at 20 °C	$\pm 20\%$
Repeatability	$\leq 0.01\%$
Maximum Power Rating	0.05 W/cm at 70 °C, 0 W at 125 °C
Wiper Current	1 mA max. continuous, recommended: a few $\mu$ A
Load Impedance	1000 times $R_T$ minimum
Insulation Resistance	> 1000 M $\Omega$ , 500 V <sub>DC</sub>
Dielectric Strength	> 300 V <sub>RMS</sub> at 50 Hz

MECHANICAL SPECIFICATIONS	
Mechanical Travel (MT)	MT = TET
Body	Anodized aluminum
Rod Internal Diameter	10 LH: Ø 12 mm
Operating Force	1 N typical
Electrical Outputs	Wires, L = 300 mm
Oil	Insulating mineral hydraulic
Pressure	300 bars continuous, 1000 bars accidentally
Wiper	Precious metal multifinger

PERFORMANCE	
Life	25 million cycles typical/1 Hz/T° = 20 °C $\pm$ 5 °C/80 % TET
Temperature Limits	- 20 °C to + 80 °C
Speed at 20 °C	1.5 m/s max.



# Series REC 10 LH

Precision Linear Transducers,  
 Designed for Mounting in Hydraulic or Pneumatic Cylinder,  
 Conductive Plastic Element (Unsealed Series/Ø 10 mm)

Vishay Sfernice

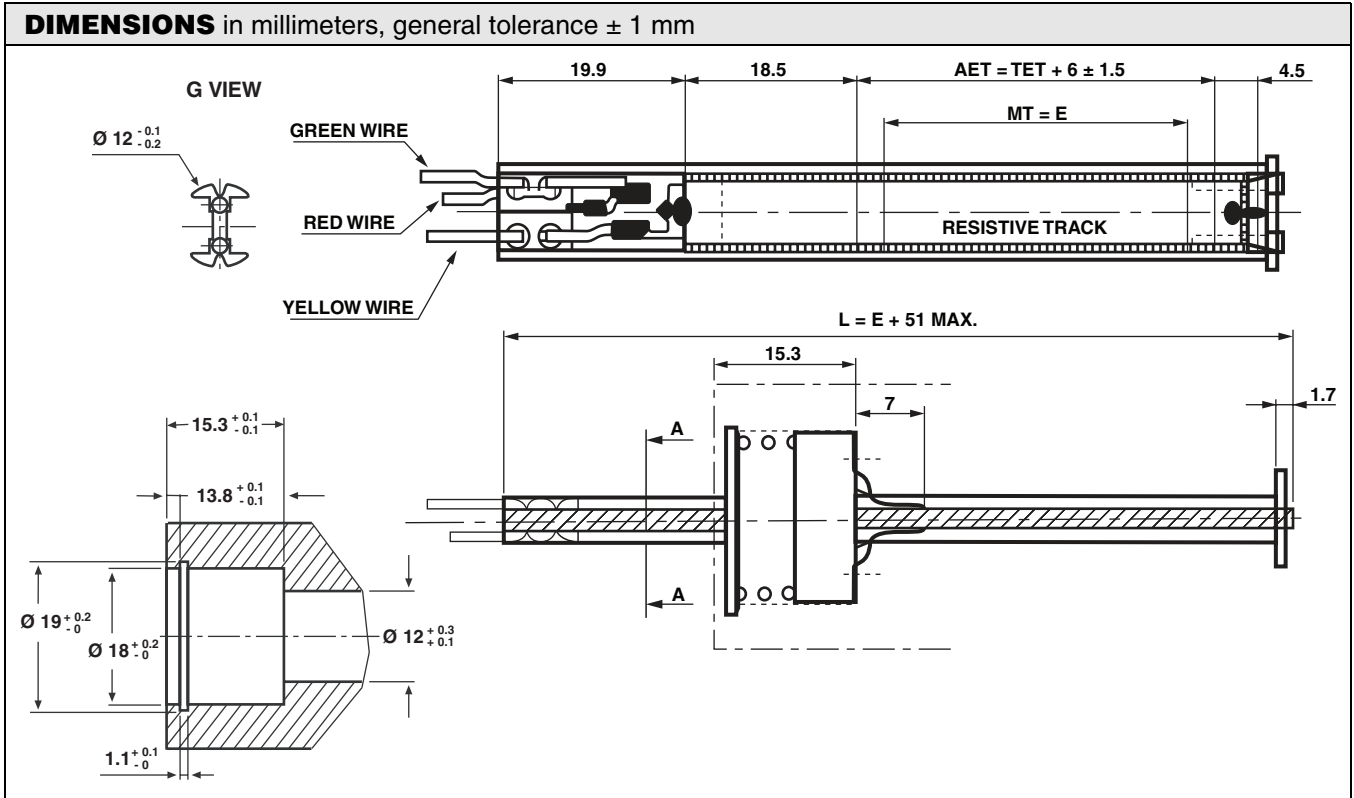

General Tolerance:  $\pm 1$  mm

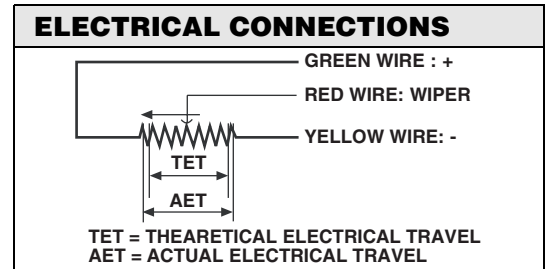
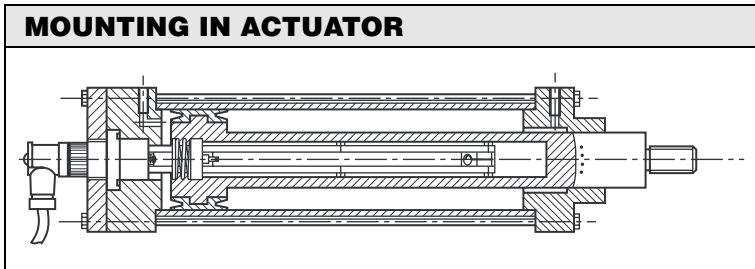

**ORDERING INFORMATION/DESCRIPTION**

REC	10	LH	4	D	152	W...	e.
SERIES	MODEL	TYPE	THEORETICAL ELECTRICAL	LINEARITY	RESISTANCE	MODIFICATIONS	LEAD FINISH
		Unsealed	Times 25 mm	A: $\leq \pm 1\%$ D: $\leq \pm 0.1\%$ E: $\leq \pm 0.05\%$ F: $\leq \pm 0.025\%$	First 2 digits are significant numbers Third indicates number of zeros	Special feature code number	

**SAP PART NUMBERING GUIDELINES**

RE	10 LH	4	D	152	W...
SERIES	MODEL	TET	LINEARITY	OHMIC VALUE	SPECIAL FEATURES

## Precision Linear Transducers, Designed for Mounting in Hydraulic or Pneumatic Cylinder, Conductive Plastic Element (Sealed Series/Ø 16 mm)



### FEATURES

- Large range of strokes from 25 to 2000 mm
- High accuracy
- Very good repeatability
- Continuous resolution
- Easy mounting



Those sensors are to be installed in the high pressure chamber of cylinders and are equipped with glass-sealed electrical outputs.

ELECTRICAL SPECIFICATIONS	
Theoretical Electrical Travel (TET = E)	From 25 mm to 2000 mm in increments of 25 mm
Independent Linearity Over TET On Request	$\leq \pm 1\%$ ; $\leq \pm 0.1\%$ $\leq \pm 0.05\%$ if $E \geq 100$ mm, $\leq \pm 0.025\%$ if $E \geq 200$ mm
Actual Electrical Travel (AET)	TET + 6 mm $\pm$ 0.5
Total Resistance $R_T$	150 $\Omega$ /cm
Resistance Tolerance at 20 °C	$\pm 20\%$
Repeatability	$\leq 0.01\%$
Maximum Power Rating	0.05 W/cm at 70 °C, 0 W at 125 °C
Wiper Current	Recommended: a few $\mu$ A - 1 mA max. (continuous)
Load Impedance	1000 times $R_T$ minimum
Insulation Resistance	> 1000 M $\Omega$ 500 V <sub>DC</sub>
Dielectric Strength	> 300 V <sub>RMS</sub> at 50 Hz

MECHANICAL SPECIFICATIONS	
Mechanical Travel MT	MT = TET
Body	Anodized aluminum
Rod Internal Diameter	16 LA: Ø 18 mm
Support	Stainless steel
Operating Force	1 N typical
Sealing	Glass-sealing on electrical outputs
Electrical Outputs On Request	Connector Wires
Oil	Insulating mineral hydraulic
Pressure	300 bars continuous, 1000 bars accidentally
Wiper	Precious metal multifinger

PERFORMANCE	
Life	25 million cycles typical/1 Hz/T° = 20 °C $\pm$ 5 °C/80 % TET
Temperature Limits	- 20 °C to + 80 °C
Speed at 20 °C	1.5 m/s max.



# Series REC 16 LA

Precision Linear Transducers, Designed for Mounting in Hydraulic or Pneumatic Cylinder, Conductive Plastic Element  
 Vishay Sfernice  
 (Sealed Series/Ø 16 mm)

## DIMENSIONS in millimeters, general tolerance $\pm 1$ mm

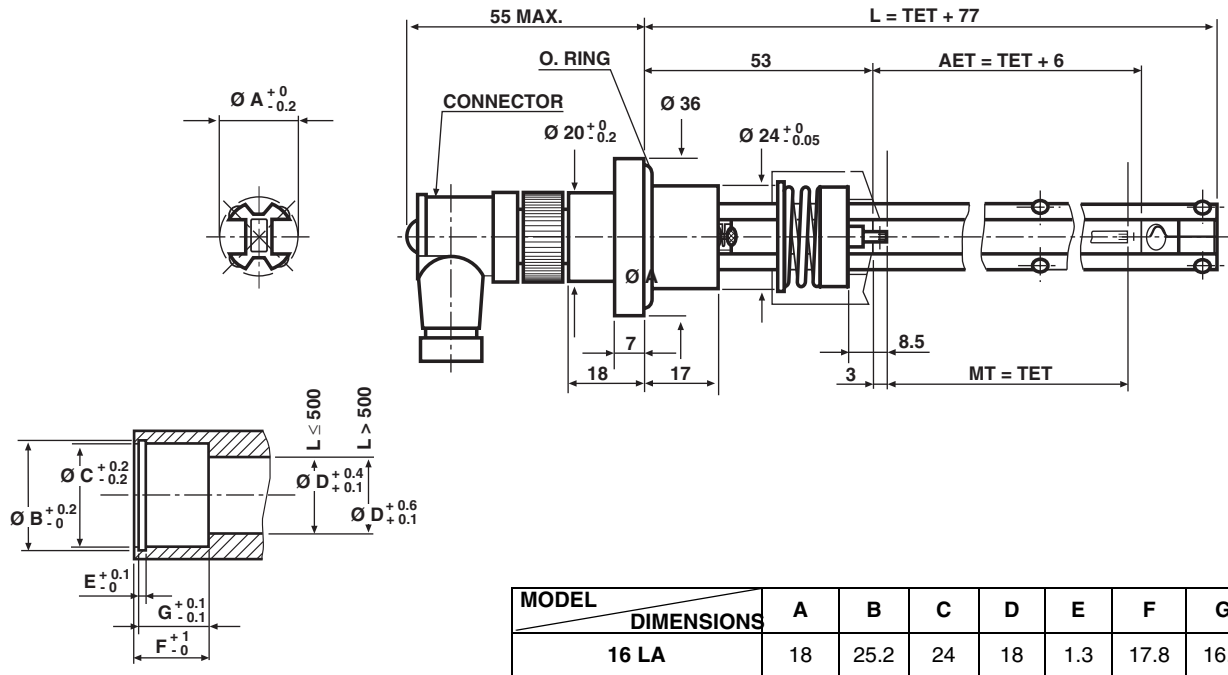

## ELECTRICAL CONNECTIONS

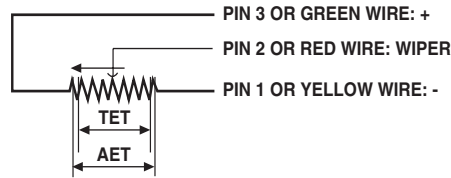

TET = Theoretical electrical travel  
 AET = Actual electrical travel

## MOUNTING IN ACTUATOR

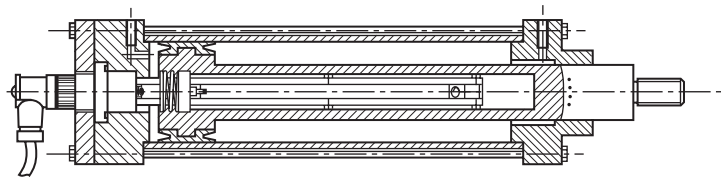

# Series REC 16 LA



Vishay Sfernice Precision Linear Transducers, Designed for Mounting in Hydraulic or Pneumatic Cylinder, Conductive Plastic Element (Sealed Series/Ø 16 mm)

**DIMENSIONS** in millimeters, general tolerance  $\pm 1$  mm

**OTHER DESIGNS OF SUPPORT**

...W04200

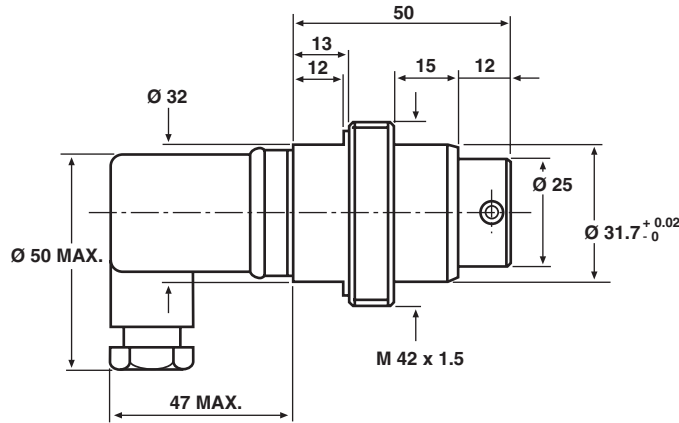

...W04700

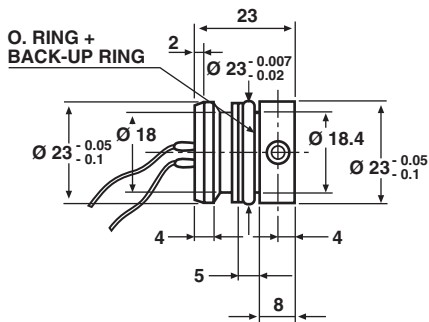

...W04707

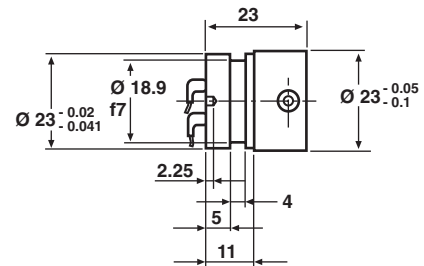

**ORDERING INFORMATION/DESCRIPTION**

REC SERIES	16 MODEL	LA TYPE	4 THEORETICAL ELECTRICAL TRAVEL	D LINEARITY	152 RESISTANCE	W... MODIFICATIONS	e. LEAD FINISH
		Sealed	Times 25 mm	A: $\leq \pm 1\%$ D: $\leq \pm 0.1\%$ E: $\leq \pm 0.05\%$ F: $\leq \pm 0.025\%$	First 2 digits are significant numbers Third indicates number of zeros	Special feature code number	

**SAP PART NUMBERING GUIDELINES**

RE SERIES	16 LA MODEL	4 TET	D LINEARITY	152 OHMIC VALUE	W... SPECIAL FEATURES
-----------	-------------	-------	-------------	-----------------	-----------------------

## Precision Linear Transducers, Designed for Mounting in Hydraulic or Pneumatic Cylinder, Conductive Plastic Element (Unsealed Series/Ø 16 mm)

**FEATURES**

- Large range of strokes from 25 to 2000 mm
- High accuracy
- Very good repeatability
- Continuous resolution
- Easy mounting



These unsealed sensors are suitable for installation in the high pressure chamber of cylinders.

<b>ELECTRICAL SPECIFICATIONS</b>	
Theoretical Electrical Travel (TET) = E	From 25 mm to 2000 mm in increments of 25 mm
Independent Linearity (over TET) On Request	$\leq \pm 1\%$ ; $\leq \pm 0.1\%$ $\leq \pm 0.05\%$ if $E \geq 100$ mm, $\leq \pm 0.025\%$ if $E \geq 200$ mm
Actual Electrical Travel (AET)	TET + 6 mm $\pm$ 0.5
Total Resistance $R_T$	150 $\Omega$ /cm
Resistance Tolerance at 20 °C	$\pm 20\%$
Repeatability	$\leq 0.01\%$
Maximum Power Rating	0.05 W/cm at 70 °C, 0 W at 125 °C
Wiper Current	Recommended: a few $\mu$ A - 1 mA max. (continuous)
Load Impedance	1000 times $R_T$ minimum
Insulation Resistance	> 1000 M $\Omega$ , 500 V <sub>DC</sub>
Dielectric Strength	> 300 V <sub>RMS</sub> at 50 Hz

<b>MECHANICAL SPECIFICATIONS</b>	
Mechanical Travel (MT)	MT = TET
Body	Anodized aluminum
Rod Internal Diameter	16 LH: Ø 18 mm
Support	2 screws
Operating Force	1 N typical
Electrical Outputs	Wires 300 mm long
Oil	Insulating mineral hydraulic
Pressure	300 bars continuous, 1000 bars accidentally
Wiper	Precious metal multifinger

<b>PERFORMANCE</b>	
Life	25 million cycles typical/1 Hz/T° = 20 °C $\pm$ 5 °C/80 % TET
Temperature Limits	- 20 °C to + 80 °C
Speed at 20 °C	1.5 m/s max.



# Series REC 16 LH



Vishay Sfernice Precision Linear Transducers, Designed for Mounting in Hydraulic or Pneumatic Cylinder, Conductive Plastic Element (Unsealed Series/Ø 16 mm)

## DIMENSIONS in millimeters, general tolerance $\pm 1$ mm

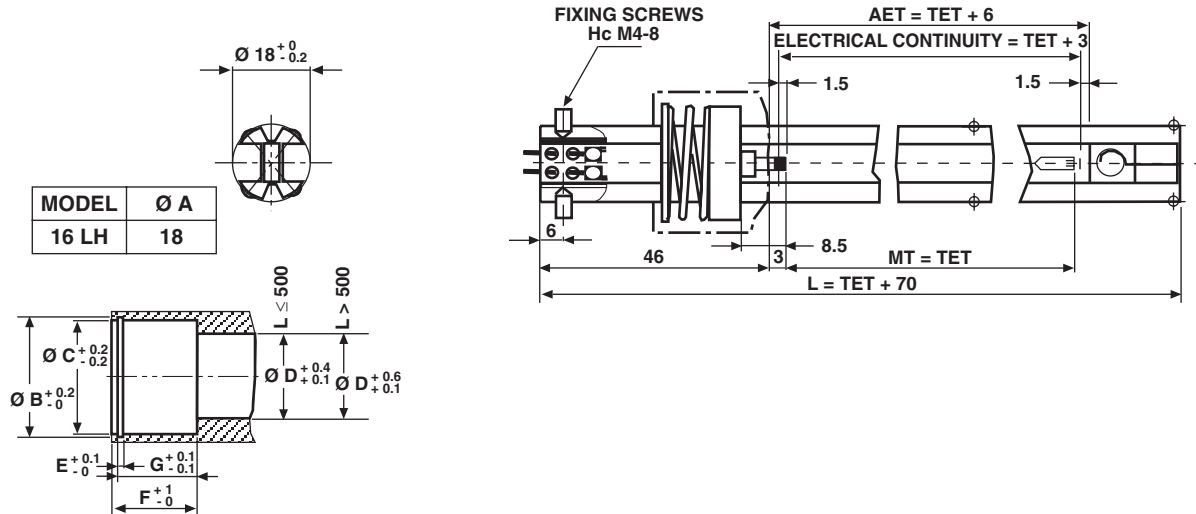

MODEL	B	C	D	E	F	G
16 LH	25.2	24	18	1.3	17.8	16.3

## MOUNTING IN ACTUATOR

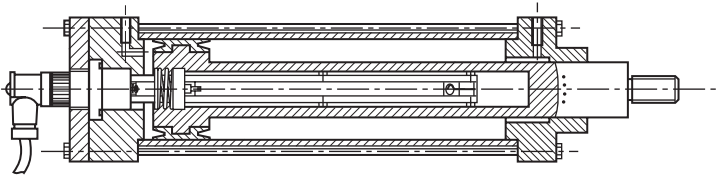

On these models:  
Cylinder sealing and electrical connections required

## ELECTRICAL CONNECTIONS

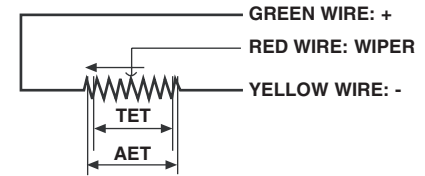

TET = THEORETICAL ELECTRICAL TRAVEL  
AET = ACTUAL ELECTRICAL TRAVEL

## ORDERING INFORMATION/DESCRIPTION

REC	16	LH	4	D	152	W...	e.
SERIES	MODEL	TYPE	THEORETICAL ELECTRICAL	LINEARITY	RESISTANCE	MODIFICATIONS	LEAD FINISH
		Unsealed	Times 25 mm	A: $\leq \pm 1\%$ D: $\leq \pm 0.1\%$ E: $\leq \pm 0.05\%$ F: $\leq \pm 0.025\%$	First 2 digits are significant numbers 3rd digit indicates number of zeros	Special feature code number	

## SAP PART NUMBERING GUIDELINES

RE	16 LH	4	D	152	W...
SERIES	MODEL	TET	LINEARITY	OHMIC VALUE	SPECIAL FEATURES

## Precision Linear Transducers, Conductive Plastic, up to 450 mm

### FEATURES

- Large measurement range
- High accuracy  $\pm 1\%$  down to  $\pm 0.05\%$
- Essentially infinite resolution
- Easy mounting

**RoHS**  
COMPLIANT

The 110 L is a compact, robust, easily mounted precision industrial motion transducer.

<b>ELECTRICAL SPECIFICATIONS</b>	
Theoretical Electrical Travel (TET) = E	25 mm to 450 mm in increments of 25 mm
Independent Linearity (over TET) On Request	$\leq \pm 1\% \leq \pm 0.1\%$ $\leq \pm 0.05\%$ for $E \geq 100$ mm
Actual Electrical Travel (AET)	See Electrical Connections Table 1
Repeatability	$\leq 0.01\%$
Ohmic Values ( $R_T$ )	From 400 $\Omega$ /cm to 2 k $\Omega$ /cm
Resistance Tolerance at 20 °C	$\pm 20\%$
Maximum Power Rating	0.05 W/cm at 70 °C, 0 W at 125 °C
Wiper Current	Recommended: a few $\mu$ A - 1 mA max. (continuous)
Load Resistance	Minimum $10^3 \times R_T$
Insulation Resistance	$\geq 1000$ M $\Omega$ , 500 V <sub>DC</sub>
Dielectric Strength	$\geq 750$ V <sub>RMS</sub> , 50 Hz

<b>MECHANICAL SPECIFICATIONS</b>	
Mechanical Travel	TET + 6 mm min.
Housing	Anodized aluminum
Operating Force	5 N typical
Shaft (Free Rotation)	Stainless steel
Termination On Request	Connector: 723 series by cable
Wiper	Precious metal multifinger
Mounting	Movable brackets

<b>PERFORMANCE</b>	
Operating Life	40 million cycles typical/1 Hz/T° = 20 °C $\pm$ 5 °C/80 % TET
Temperature Range	- 55 °C to + 125 °C
Mechanical Shocks on 3 Axes	50 g - 11 ms - half sine
Sine Vibration on 3 Axes	1.5 mm peak to peak or 15 g - 10 Hz - 2000 Hz
Speed (max.)	8 m/s for $f < 2$ Hz; 3 m/s for $f < 5$ Hz

# Series REC 110 L

Vishay Sfernice

Precision Linear Transducers, Conductive Plastic,  
up to 450 mm



## DIMENSIONS in millimeters, general tolerance $\pm 1$ mm

### STANDARD MODEL

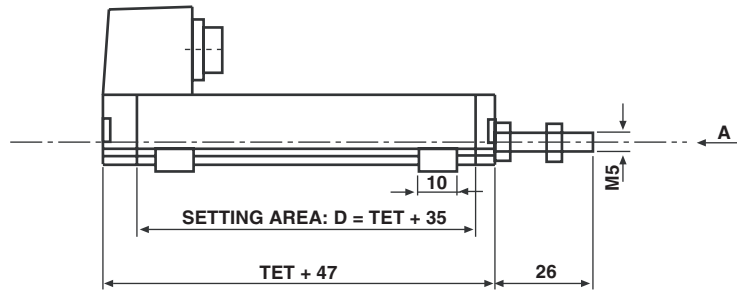
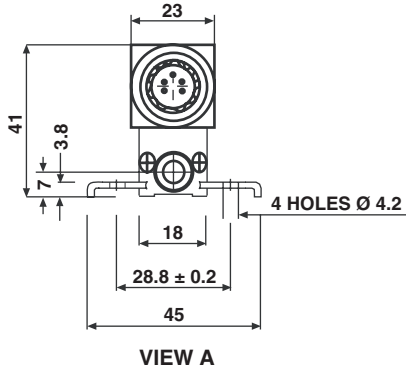

### WITH CABLE OUTPUT: W04029

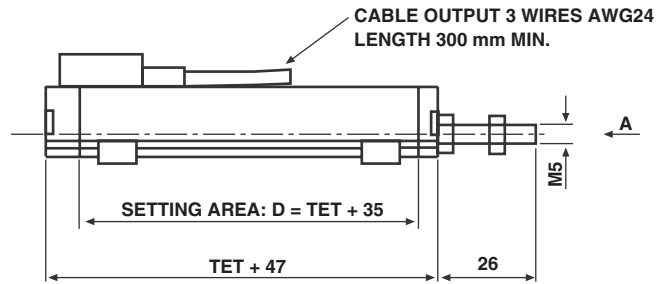
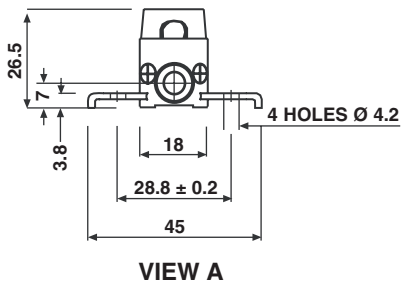

## ELECTRICAL CONNECTIONS

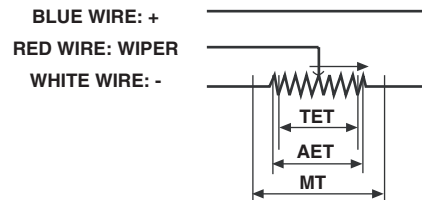
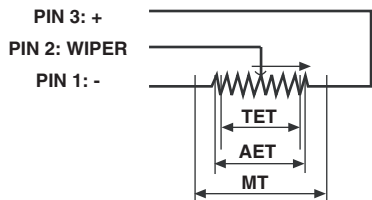

TET = THEORETICAL ELECTRICAL TRAVEL  
AET = Actual ELECTRICAL TRAVEL  
MT = MECHANICAL TRAVEL

Table 1

THEORETICAL ELECTRICAL TRAVEL TET	ACTUAL ELECTRICAL TRAVEL AET	TOLERANCE
From 25 mm to 275 mm	$TET + 1$ mm	$\pm 0.5$ mm
From 300 mm to 450 mm	$TET + 1$ mm	$\pm 0.8$ mm



**OPTION: SPRING LOADED SHAFT DIMENSIONS** in millimeters, general tolerance  $\pm 1$  mm

**110L WITH SPRING LOADED SHAFT: W04030**

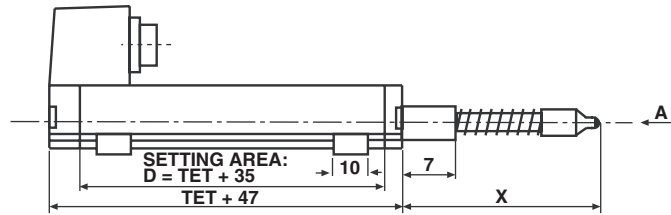
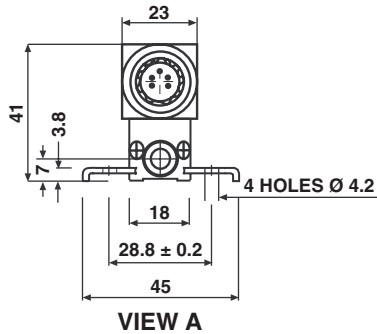
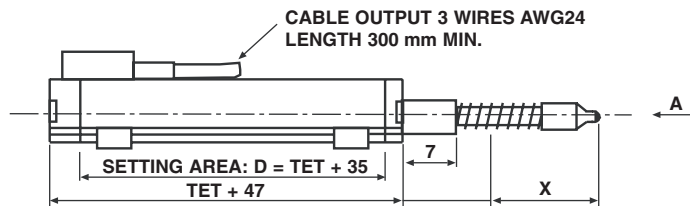
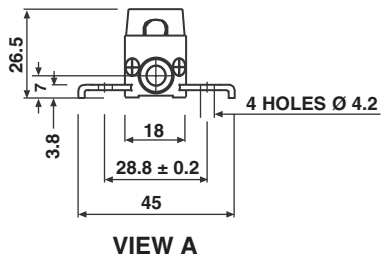

Table 2

MODEL	X
110 L1	75
110 L2	112
110 L3	150
110 L4	188

**110L WITH CABLE OUTPUT AND SPRING LOADED SHAFT: W04031**



# Series REC 110 L

Vishay Sfernice

Precision Linear Transducers, Conductive Plastic,  
up to 450 mm



**ACCESSORIES ON REQUEST DIMENSIONS** in millimeters, general tolerance  $\pm 1$  mm

- 1) FEMALE CONNECTOR  
Vishay's Reference: 328870

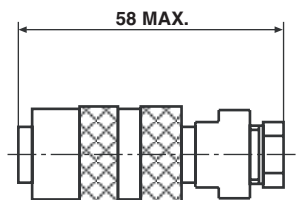

- 2) SPECIAL BALL JOINT  
Vishay's reference: 323654

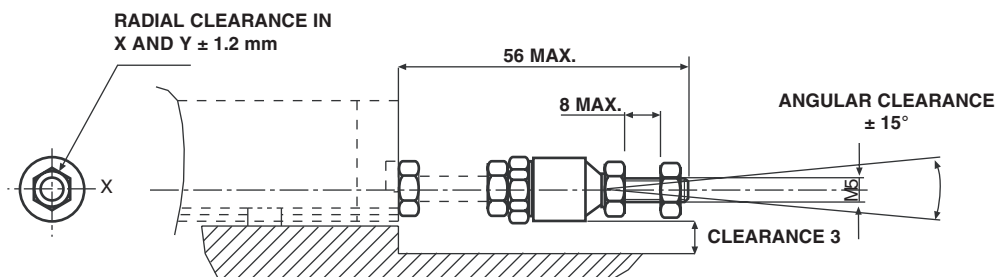

**ORDERING INFORMATION/DESCRIPTION**

REC	110	L	3	D	103	W...	e.
SERIES	MODEL	NUMBER OF TRACKS	THEORETICAL ELECTRICAL	LINEARITY	OHMIC VALUE	MODIFICATIONS	LEAD FINISH
		L = 1 track	Times 25 mm	A: $\pm 1\%$ D: $\pm 0.1\%$ E: $\pm 0.05\%$	First 2 digits are significant numbers 3rd digit indicates number of zeros	Special feature code number	

**SAP PART NUMBERING GUIDELINES**

RE	110 L	3	D	103	W....
SERIES	MODEL	TET	LINEARITY	OHMIC VALUE	SPECIAL FEATURES

## Precision Linear Transducers, Conductive Plastic, up to 1000 mm



### FEATURES

- Measurement range 25 mm to 1000 mm
- High accuracy  $\pm 1\%$  down to  $\pm 0.025\%$
- Excellent repeatability
- Essentially infinite resolution
- Non sensitive to temperature variations

**RoHS**  
COMPLIANT

The 115 L is a simply mounted, robust, high precision industrial linear motion transducer.

<b>ELECTRICAL SPECIFICATIONS</b>	
Theoretical Electrical Travel (TET) = E	From 25 mm to 1000 mm in increments of 25 mm
Independent Linearity (over TET) On Request	$\leq \pm 1\% \leq \pm 0.1\%$ $\leq \pm 0.05\%$ for $E \geq 100$ mm $\leq \pm 0.025\%$ for $E \geq 200$ mm
Actual Electrical Travel (AET)	AET = TET + 1.5 mm min.
Ohmic Values ( $R_T$ )	400 $\Omega$ /cm to 2 k $\Omega$ /cm
Resistance Tolerance at 20 °C	$\pm 20\%$
Repeatability	$\leq \pm 0.01\%$
Maximum Power Rating	0.05 W/cm at 70 °C, 0 W at 125 °C
Wiper Current	Recommended: a few $\mu$ A - 1 mA max. (continuous)
Load Resistance	minimum $10^3 \times R_T$
Insulation Resistance	$\geq 1000$ M $\Omega$ , 500 V <sub>DC</sub>
Dielectric Strength	$\geq 1000$ V <sub>RMS</sub> , 50 Hz
Protection Resistor	Integrated inside the transducer to protect against errors when setting up (short circuit)

<b>MECHANICAL SPECIFICATIONS</b>	
Mechanical Travel	$E + 8 \pm 2$ mm
Housing	Anodized aluminum
Operating Force	7.5 N typical
Shaft (Free Rotation)	Stainless steel
Termination	Hydraulic type connector DIN 43650
Wiper	Precious metal multifinger
Mounting	Movable brackets

<b>PERFORMANCE</b>	
Operating Life	40 million cycles typical/1 Hz/T° = 20 °C $\pm$ 5 °C/80 % TET
Temperature Range	- 55 °C to + 125 °C
Sine Vibration on 3 Axes	1.5 mm peak to peak 0 - 10 Hz 15 g - 10 Hz - 2000 Hz
Mechanical Shocks on 3 Axes	50 g - 11 ms - half sine
Speed (max.)	8 m/s for $f < 2$ Hz; 3 m/s for $f < 5$ Hz

# Series REC 115 L

Vishay Sfernice

Precision Linear Transducers, Conductive Plastic,  
up to 1000 mm



## DIMENSIONS in millimeters, general tolerance $\pm 1$ mm

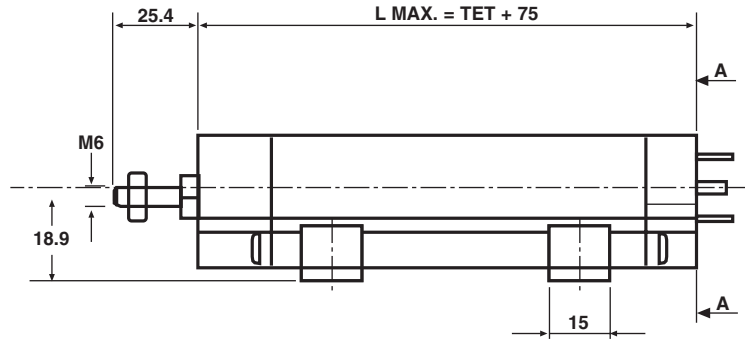
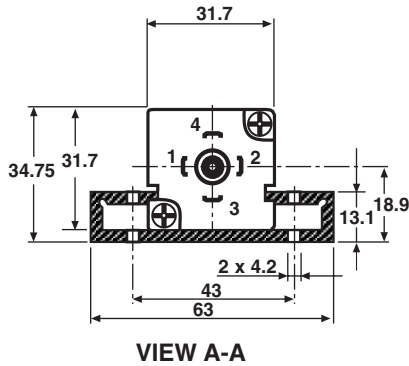

## ELECTRICAL CONNECTIONS

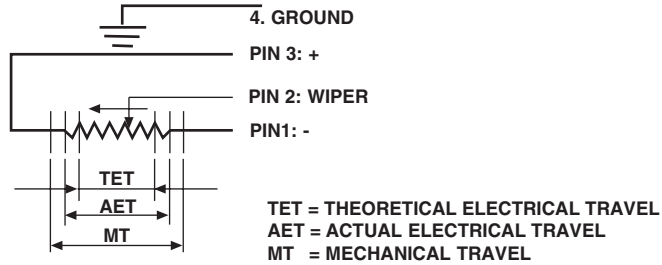

## ACCESSORIES ON REQUEST DIMENSIONS in millimeters, general tolerance $\pm 1$ mm

1) FEMALE CONNECTOR  
Vishay's Reference: 3248610

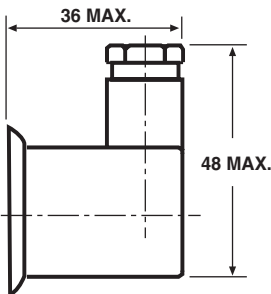

2) SPECIAL BALL JOINT ON SHAFT  
Vishay's reference: 323655

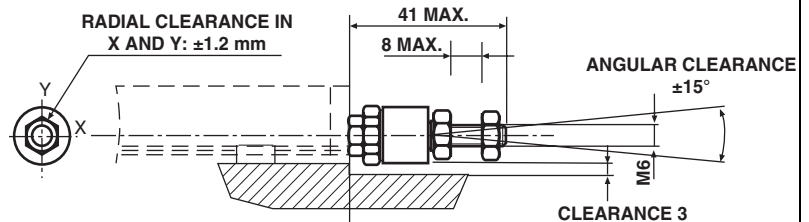

## ORDERING INFORMATION/DESCRIPTION

REC SERIES	115 MODEL	L NUMBER OF TRACKS	23 THEORETICAL ELECTRICAL TRAVEL	D LINEARITY	103 OHMIC VALUE	W... MODIFICATIONS	e. LEAD FINISH
		L = 1	Times 25 mm	A: $\pm 1\%$ D: $\pm 0.1\%$ E: $\pm 0.05\%$ F: $\pm 0.025\%$	First 2 digits are significant numbers 3rd digit indicates number of zeros	Special feature code number	

## SAP PART NUMBERING GUIDELINES

RE SERIES	115 L MODEL	23 TET	D LINEARITY	103 OHMIC VALUE	W... SPECIAL FEATURES
-----------	-------------	--------	-------------	-----------------	-----------------------

## Precision Linear Transducers, Conductive Plastic, up to 3000 mm



### FEATURES

- Measurement range 25 mm to 3000 mm
- High accuracy  $\pm 1\%$  down to  $\pm 0.025\%$
- Excellent repeatability
- Essentially infinite resolution
- Simple mounting
- Actuation tolerant to some misalignment
- Reduced bulk



The 139 L is a robust industrial linear motion transducer with a side actuation, ideally suited for applications with very long travels.

<b>ELECTRICAL SPECIFICATIONS</b>	
Theoretical Electrical Travel (TET) = E	From 25 mm to 3000 mm in increments of 25 mm
Independent Linearity (over TET) On Request	$\leq \pm 1\%$ ; $\leq \pm 0.1\%$ $\leq \pm 0.05\%$ for $E \geq 100$ mm $\leq \pm 0.025\%$ for $E \geq 200$ mm
Actual Electrical Travel (AET)	AET = E + 1.5 mm min.
Ohmic Value ( $R_T$ )	400 $\Omega$ /cm to 2 k $\Omega$ /cm
Resistance Tolerance at 20 °C	$\pm 20\%$
Repeatability	$\leq 0.01\%$
Maximum Power Rating	0.05 W/cm at 70 °C, 0 W at 125 °C
Wiper Current	Recommended: a few $\mu$ A - 1 mA max. (continuous)
Load Resistance	Minimum $10^3 \times R_T$
Insulation Resistance	$\geq 1000$ M $\Omega$ , 500 V <sub>DC</sub>
Dielectric Strength	$\geq 1000$ V <sub>RMS</sub> , 50 Hz

<b>MECHANICAL SPECIFICATIONS</b>	
Mechanical Travel (MT)	See dimensions table 1
Housing	Anodized aluminum
Operating Force	2.5 N typical
Coupling	Self alignment
Termination	Hydraulic type connector DIN 43650
Wiper	Precious metal multifinger
Sealed to	IP53
Mounting	Movable brackets

<b>PERFORMANCE</b>	
Operating Life	40 million cycles typical/1 Hz/T° = 20 °C $\pm$ 5 °C/80 % TET
Temperature Range	- 55 °C to + 125 °C
Sine Vibration on 3 Axes	1.5 mm peak to peak or 15 g - 10 Hz - 2000 Hz
Mechanical Shocks on 3 Axes	50 g - 11 ms - half sine
Speed (max.)	8 m/s for $f < 2$ Hz; 3 m/s for $f < 5$ Hz



# Series REC 139 L

Vishay Sfernice

Precision Linear Transducers, Conductive Plastic,  
up to 3000 mm



## DIMENSIONS in millimeters, general tolerance $\pm 1$ mm

### STANDARD MODEL

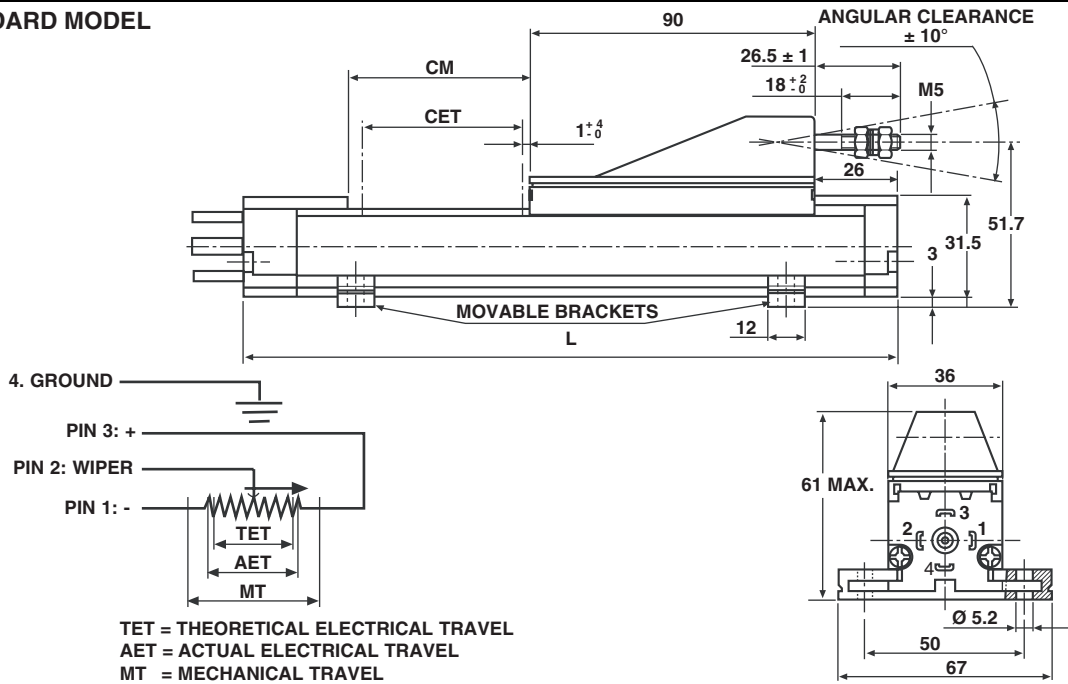

LENGTH	AET	MT	L
L1 to L20	TET + 1.5 min.	TET + 7 min.	TET + 158 max.
L21 to L40	TET + 1.5 min.	TET + 11 min.	TET + 163 max.
L41 to L120	TET + 1.5 min.	TET + 15 min.	TET + 169 max.

## ELECTRICAL CONNECTIONS

**FEMALE CONNECTOR**  
Vishay's Reference: 3248610

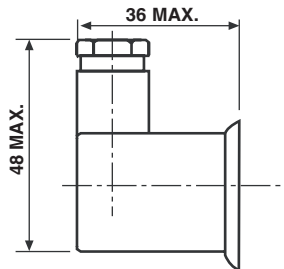

## ORDERING INFORMATION/DESCRIPTION

REC	139	L	43	D	103	W...	e3
SERIES	MODEL	NUMBER OF TRACKS	THEORETICAL ELECTRICAL	LINEARITY	OHMIC VALUE	MODIFICATIONS	LEAD FINISH
		L = 1	Times 25 mm	A: $\pm 1\%$ D: $\pm 0.1\%$ E: $\pm 0.05\%$ F: $\pm 0.025\%$	First 2 digits are significant numbers 3rd digit indicates number of zeros	Special feature code number	Pure tin

## SAP PART NUMBERING GUIDELINES

RE	139 L	43	D	103	W....
SERIES	MODEL	TET	LINEARITY	OHMIC VALUE	SPECIAL FEATURES

## Conductive Plastic Motion Transducer Elements (KIT), up to 1000 mm



The LMF is a reduced bulk, precision motion transducer, designed for easy integration into equipment.

### FEATURES

- Measurement range 25 mm to 1000 mm
- High accuracy  $\pm 1\%$  down to  $\pm 0.025\%$
- Good repeatability
- Simple and flexible mounting
- Essentially infinite resolution

Made in two separate parts:

- the sensing element
- the wiper

Special designs available on request.



**RoHS**  
COMPLIANT

<b>ELECTRICAL SPECIFICATIONS</b>	
Theoretical Electrical Angle (TEA = E)	From 25 mm to 1000 mm in increments of 25 mm
Independent Linearity (over TET) On Request	$\leq \pm 1\%$ ; $\leq \pm 0.1\%$ $\leq \pm 0.05\%$ for $E \geq 100$ mm $\leq \pm 0.025\%$ for $E \geq 200$ mm
Actual Electrical Travel (AET)	AET = TET + 2 mm
Ohmic Value	From 400 $\Omega$ /cm to 2 k $\Omega$ /cm
Resistance Tolerance at 20 °C	$\pm 20\%$
Repeatability	$\leq 0.01\%$
Maximum Power Rating	0.05 W/cm at 40 °C      0 W at 85 °C
Wiper Current	Recommended: a few $\mu$ A - 1 mA max. (continuous)
Load Resistance	Minimum $10^3 \times R_T$
Insulation Resistance	$\geq 1000$ M $\Omega$ , 500 V <sub>DC</sub>
Dielectric Strength	$\geq 750$ V <sub>RMS</sub> , 50 Hz

<b>MECHANICAL SPECIFICATIONS</b>	
Support of Element On Request	Fiberglass epoxy Plastic moulding
Wiper (Non Insulated) On Request	Precious metal multifinger Insulated
Terminals On Request	Soldering pads By wires
Fixing On Request	Glued: Double face Isotac Screwed: Holes in the support

<b>PERFORMANCE</b>	
Operating Life	25 million cycles typical/1 Hz/T° = 20 °C $\pm$ 5 °C/80 % TET
Temperature Range	- 55 °C to + 125 °C

# Series KIT LMF

Vishay Sfernice Conductive Plastic Motion Transducer Elements (KIT),  
up to 1000 mm



## DIMENSIONS in millimeters, general tolerance $\pm 0.2$ mm

STANDARD MODEL: LMF...W02851

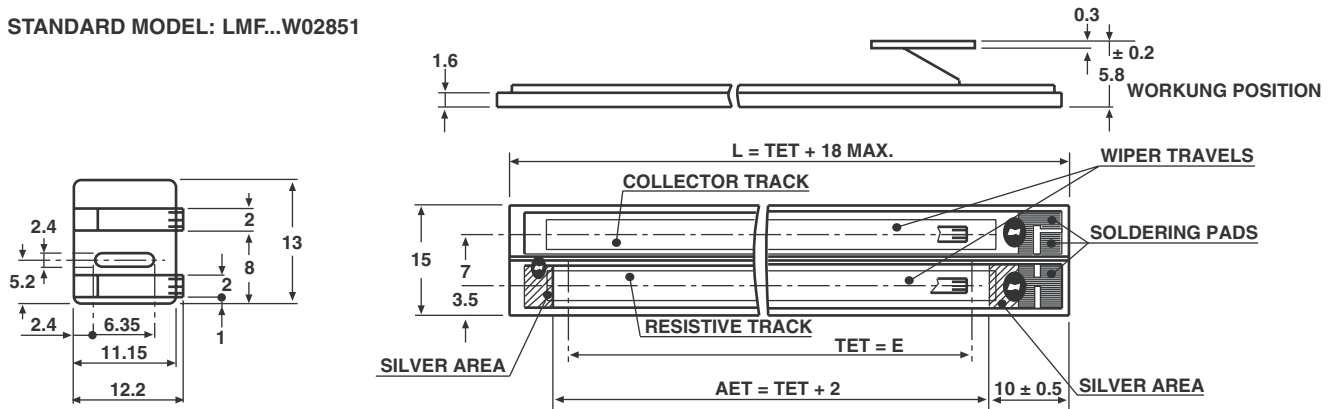

## EXAMPLES OF SPECIAL DESIGNS

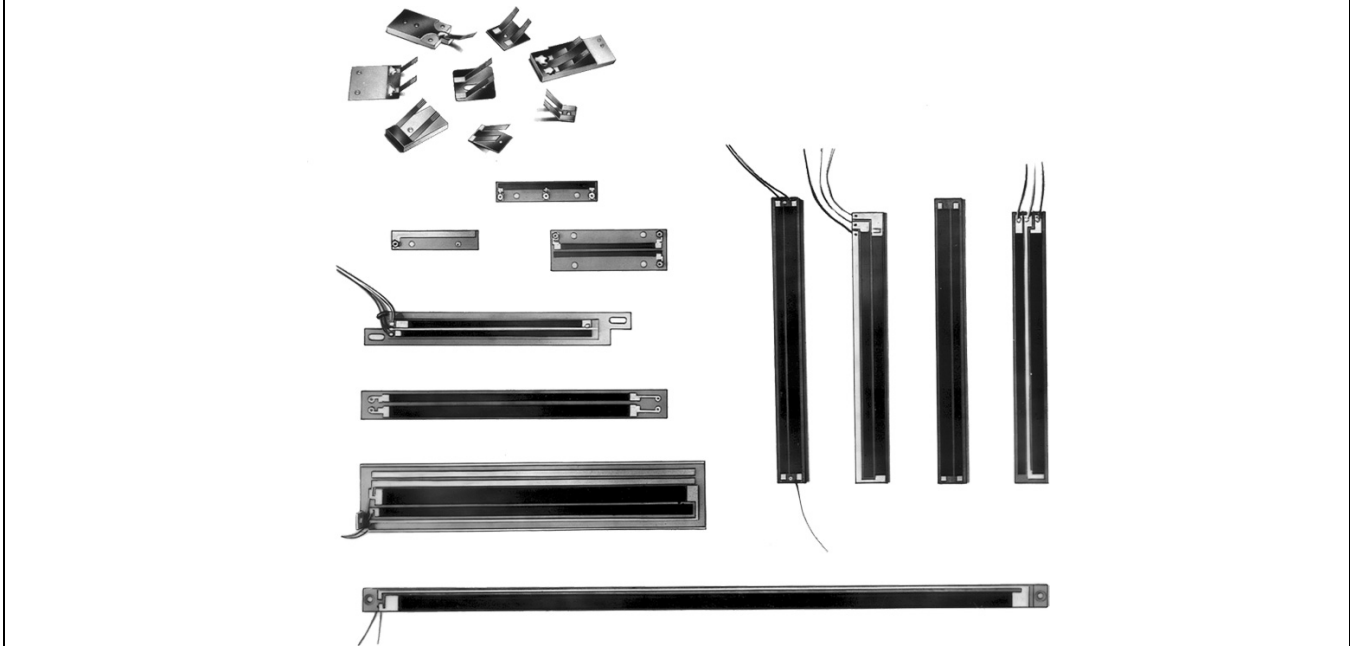

## ORDERING INFORMATION/DESCRIPTION

KIT SERIES	LM MODEL	F CONDUCTOR	3 THEORETICAL ELECTRICAL TRAVEL Times 25 mm	D LINEARITY	103 OHMIC VALUE	W... MODIFICATIONS	e. LEAD FINISH
		F: Plastic S: Serigraphy		A: $\pm 1\%$ D: $\pm 0.1\%$ E: $\pm 0.05\%$ F: $\pm 0.025\%$	First 2 digits are significant numbers 3rd digit indicates number of zeros	Special feature code number	

## SAP PART NUMBERING GUIDELINES

LMF MODEL	3 TET	D LINEARITY	103 OHMIC VALUE	W... SPECIAL FEATURES
-----------	-------	-------------	-----------------	-----------------------

## Precision Linear Transducers, Conductive Plastic, up to 450 mm

**FEATURES**

- Measurement range 25 mm to 450 mm
- High accuracy  $\pm 1\%$  down to  $\pm 0.025\%$
- Essentially infinite resolution
- Long life
- Sealed on request

**RoHS  
COMPLIANT**

The 34 L is a compact, accurate and adaptable motion transducer for both industrial and military markets.

<b>ELECTRICAL SPECIFICATIONS</b>	
Theoretical Electrical Travel (TET = E) in Increments of 25 mm	25 mm 450 mm
Independent Linearity (over TET) On Request	$\leq \pm 1\%$ - $\leq \pm 0.1\%$ $\leq \pm 0.05\%$ for $E \geq 100$ mm $\leq \pm 0.025\%$ for $E \geq 200$ mm
Actual Electrical Travel (AET)	See table 1
Ohmic Values ( $R_T$ )	From 400 $\Omega$ /cm to 2 k $\Omega$ /cm
Resistance Tolerance at 20 °C	$\pm 20\%$
Repeatability	$\leq 0.01\%$
Maximum Power Rating	0.05 W/cm at 70 °C, 0 W at 125 °C
Wiper Current	Recommended: a few $\mu$ A - 1 mA max. (continuous)
Load Resistance	Minimum $10^3 \times R_T$
Number of Tracks	1; on request 2
Insulation Resistance	$\geq 1000$ M $\Omega$ , 500 V <sub>DC</sub>
Dielectric Strength	$\geq 750$ V <sub>RMS</sub> , 50 Hz

<b>MECHANICAL SPECIFICATIONS</b>	
Mechanical Travel	TET + 2 mm min.
Housing	Anodized aluminum
Operating Force On Request	0.35 N typical (standard model)      2.50 N typical (sealed model)
Shaft (Free Rotation)	Stainless steel
Termination On Request	3 wires PTFE AWG-30 L = 300 mm cable or connector
Wiper	Precious metal multifinger
Sealing	IP65 on request

<b>PERFORMANCE</b>	
Operating Life	25 million cycles typical/1 Hz/T° = 20 °C $\pm$ 5 °C/80 % TET
Temperature Range	- 55 °C to + 125 °C
Sine Vibration on 3 Axes	1.5 mm peak to peak or 15 g - 10 Hz - 2000 Hz
Mechanical Shocks on 3 Axes	50 g - 11 ms - half sine

# Series REC 34 L

Vishay Sfernice

Precision Linear Transducers, Conductive Plastic,  
up to 450 mm



## STANDARD MODEL DIMENSIONS in millimeters, general tolerance $\pm 1$ mm

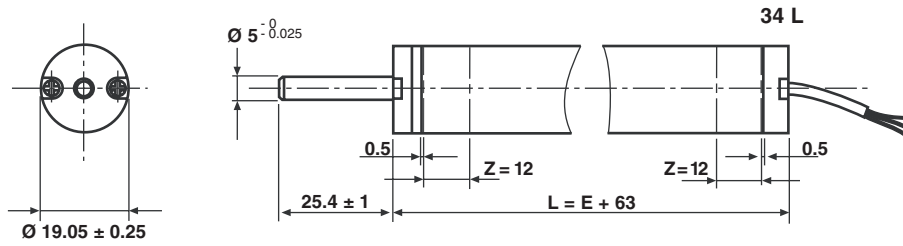

Z = TIGHTENING ZONE

## ELECTRICAL CONNECTIONS

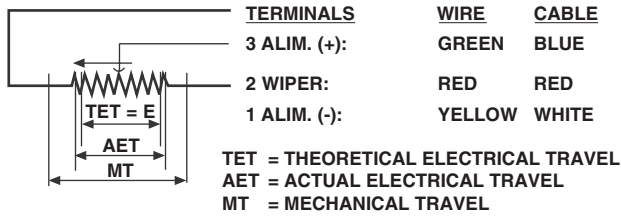

TET = E	AET	TOL.
25 mm to 275 mm	E + 1 mm	$\pm 0.5$ mm
300 mm to 450 mm	E + 1 mm	$\pm 0.8$ mm

## ACCESSORIES ON REQUEST - DIMENSIONS in millimeters, general tolerance $\pm 3$ mm

Clamp for 34L  
Vishay Reference: CQ00051

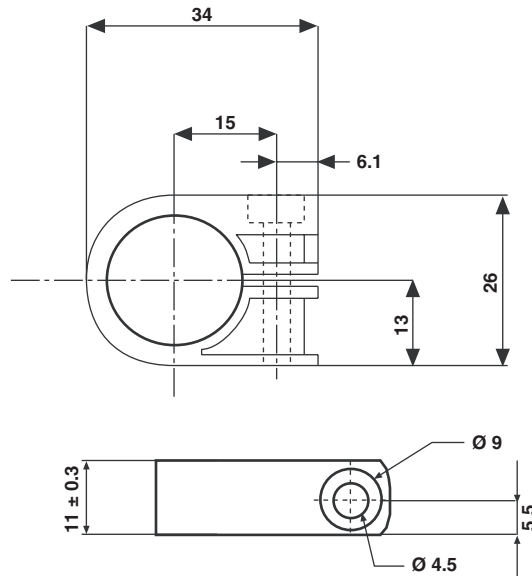



**OPTIONS - DIMENSIONS** in millimeters, general tolerance  $\pm 1$  mm

**OPTION 1: SEALED (IP65): W03280**

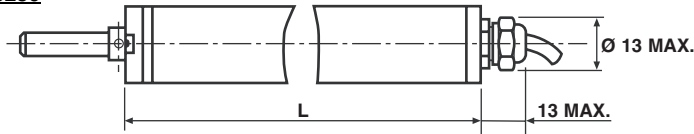

MODEL	CODE	L
34 L	W03280	TET + 83.5

**OPTION 2: DELIVERED WITH CLAMPS AND BINDER CONNECTOR 680: W05013**

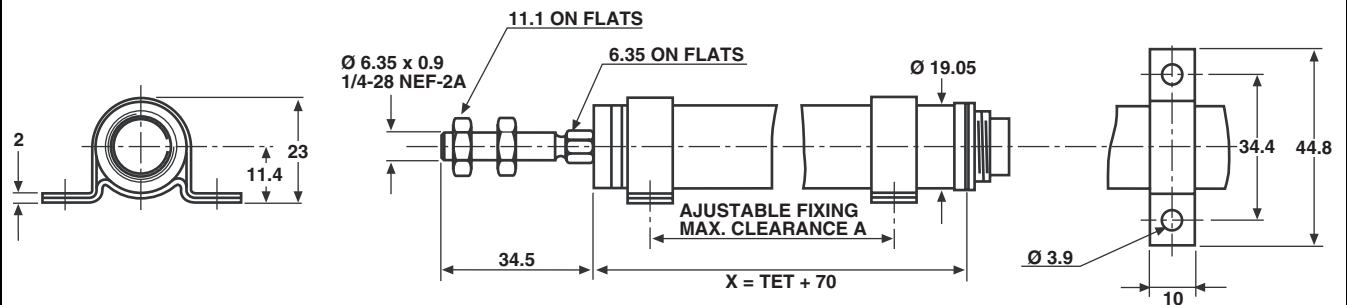

**OPTION 3: SPRING LOADED SHAFT: OUTPUT BY SHIELDED CABLE: W01744**

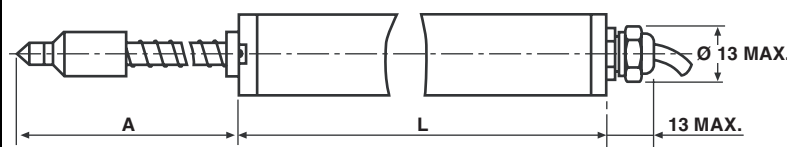

MODEL	CODE	A	L
34 L1	W01744	61.4	TET + 119.5
34 L2	W01744	93.6	
34 L3	W01744	125.8	
34 L4	W01744	158	

**OPTION 4: DOUBLE BALL JOINT: W03263**

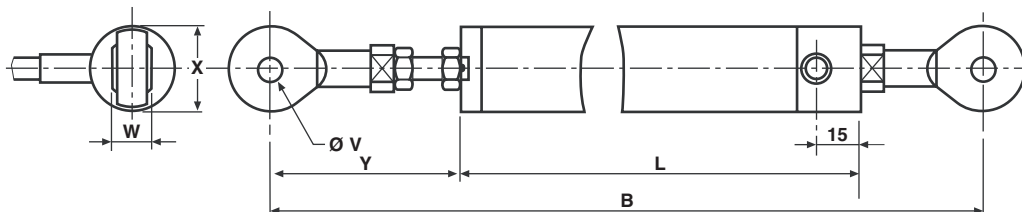

MODEL CODE	B	L	Ø V	W	X	Y	TET
34 L W03263 L1 to L5	TET + 151.6	TET + 82.8	5	8	18	42 ± 2	25 to 125
L6 to L10	TET + 173.6	TET + 104.8	5	8	18	42 ± 2	150 to 250
L11 to L12	TET + 230	TET + 161.2	5	8	18	42 ± 2	275 to 300

**ORDERING INFORMATION/DESCRIPTION**

REC	34	L	3	D	103	W...	e.
SERIES	MODEL	NUMBER OF TRACKS	THEORETICAL ELECTRICAL TRAVEL	LINEARITY	OHMIC VALUE	MODIFICATIONS	LEAD FINISH
		L = 1 track LL = 2 tracks	Times 25 mm	A: $\pm 1\%$ D: $\pm 0.1\%$ E: $\pm 0.05\%$ F: $\pm 0.025\%$	First 2 digits are significant numbers 3rd digit indicates number of zeros	Special feature code number	

**SAP PART NUMBERING GUIDELINES**

RE	34 L	3	D	103	W...
SERIES	MODEL	TET	LINEARITY	OHMIC VALUE	SPECIAL FEATURES

## Precision Linear Transducers, Conductive Plastic, up to 150 mm



### FEATURES

- Measurement range 12.5 mm to 150 mm
- High accuracy  $\pm 1\%$  down to  $\pm 0.1\%$
- Long life
- Essentially infinite resolution
- Very small dimension: External diameter = 9.52 mm



The 38 L is a very compact model especially designed for precise measurement of short travels.

ELECTRICAL SPECIFICATIONS	
Theoretical Electrical Travel (TET)	From 12.5 mm to 150 mm see table 1
Actual Electrical Travel (AET)	AET = TET + 1 mm
Independent Linearity (over TET)	$\leq \pm 1\%$ - $\leq \pm 0.5\%$ $\leq \pm 0.25\%$ for $E \geq 25$ mm $\leq \pm 0.1\%$ for $E \geq 50$ mm
Repeatability	$\leq 0.01\%$
Ohmic Values ( $R_T$ )	From 400 $\Omega$ /cm to 2 k $\Omega$ /cm
Resistance Tolerance at 20 °C	$\pm 20\%$
Wiper Current	Recommended: a few $\mu$ A - 1 mA max. (continuous)
Load Resistance	Minimum $10^3 \times R_T$
Insulation Resistance	$\geq 1000$ M $\Omega$ , 500 V <sub>DC</sub>
Dielectric Strength	$\geq 500$ V <sub>RMS</sub> , 50 Hz

MECHANICAL SPECIFICATIONS	
Mechanical Travel (MT)	MT = TET + 3 $\pm$ 1 mm
Housing	Anodized aluminum
Operating Force	0.35 N typical
Termination	3 wires PTFE AWG 28 length: 300 mm
Wiper	Precious metal multifinger

PERFORMANCE	
Operating Life	25 million cycles typical/1 Hz/T° = 20 °C $\pm$ 5 °C/80 % TET
Temperature Range	- 55 °C to + 125 °C
Sine Vibration on 3 Axes	1.5 mm peak to peak or 15 g - 10 Hz - 2000 Hz
Mechanical Shocks on 3 Axes	50 g - 11 ms - half sine

**DIMENSIONS** in millimeters, general tolerance  $\pm 1$  mm

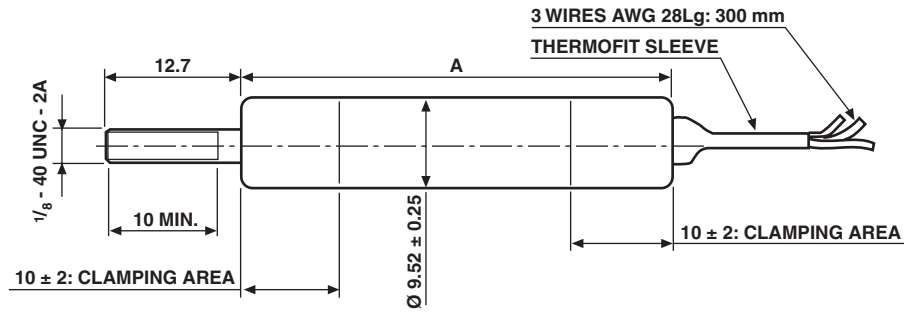

**TABLE 1**

SIZE	TET	MT	A
38 L0.5	12.5	15.5	43.5
38 L01	25	28	56
38 L02	50	53	81
38 L03	75	78	106
38 L04	100	103	131
38 L05	125	128	156
38 L06	150	153	181

**ELECTRICAL CONNECTIONS**

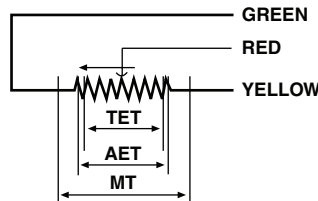

TET = THEORETICAL ELECTRICAL TRAVEL  
AET = ACTUAL ELECTRICAL TRAVEL  
MT = MECHANICAL TRAVEL

**ORDERING INFORMATION/DESCRIPTION**

REC	38	L	0.5	C	102	W...	e1
SERIES	MODEL	NUMBER OF TRACKS	ELECTRICAL TRAVEL	LINEARITY	OHMIC VALUE	MODIFICATIONS	LEAD FINISH
		L = 1 track	0.5 = 12.5 mm 1 = 25 mm 2 = 50 mm 3 = 75 mm 4 = 100 mm 5 = 125 mm 6 = 150 mm	A: $\pm 1\%$ B: $\pm 0.5\%$ C: $\pm 0.25\%$ D: $\pm 0.1\%$	First 2 digits are significant numbers 3rd digit indicates number of zeros	Special feature code number	Sn Ag Cu

**SAP PART NUMBERING GUIDELINES**

RE	38 L	0.5	C	102	W...
SERIES	MODEL	TET	LINEARITY	OHMIC VALUE	SPECIAL FEATURES



## Precision Linear Transducers, Conductive Plastic, up to 300 mm



### FEATURES

- Measurement range 25 mm to 300 mm
- High accuracy  $\pm 1\%$  down to  $\pm 0.025\%$
- Essentially infinite resolution
- Long life
- Sealed on request



The 50 L is a compact, accurate and adaptable motion transducer for both industrial and military markets.

ELECTRICAL SPECIFICATIONS	
Theoretical Electrical Travel (TET = E) in Increments of 25 mm	25 mm 300 mm
Independent Linearity (over TET) On Request	$\leq \pm 1\%$ - $\leq \pm 0.1\%$ $\leq \pm 0.05\%$ for $E \geq 100$ mm $\leq \pm 0.025\%$ for $E \geq 200$ mm
Actual Electrical Travel (AET)	AET = E + 1 mm $\pm$ 0.5 mm
Ohmic Values ( $R_T$ )	400 $\Omega$ /cm to 2 k $\Omega$ /cm
Resistance Tolerance at 20 °C	$\pm 20\%$
Repeatability	$\leq 0.01\%$
Maximum Power Rating	0.05 W/cm at 70 °C, 0 W at 125 °C
Wiper Current	Recommended: a few $\mu$ A - 1 mA max. (continuous)
Load Resistance	Minimum $10^3 \times R_T$
Number of Tracks	1; on request 2
Insulation Resistance	$\geq 1000$ M $\Omega$ , 500 V <sub>DC</sub>
Dielectric Strength	$\geq 500$ V <sub>RMS</sub> , 50 Hz

MECHANICAL SPECIFICATIONS	
Mechanical Travel	TET + 2 mm min.
Housing	Anodized aluminum
Operating Force On Request	0.35 N typical (standard model)      2.50 N typical (sealed model)
Shaft (Free Rotation)	Stainless steel
Termination On Request	3 wires PTFE AWG-30 L = 300 mm cable or connector
Wiper	Precious metal multifinger
Sealing	IP65 on request

PERFORMANCE	
Operating Life	25 million cycles typical/1 Hz/T° = 20 °C $\pm$ 5 °C/80 % TET
Temperature Range	- 55 °C to + 125 °C
Sine Vibration on 3 Axes	1.5 mm peak to peak or 15 g - 10 Hz - 2000 Hz
Mechanical Shocks on 3 Axes	50 g - 11 ms - half sine



**STANDARD MODEL DIMENSIONS** in millimeters, general tolerance  $\pm 1$  mm

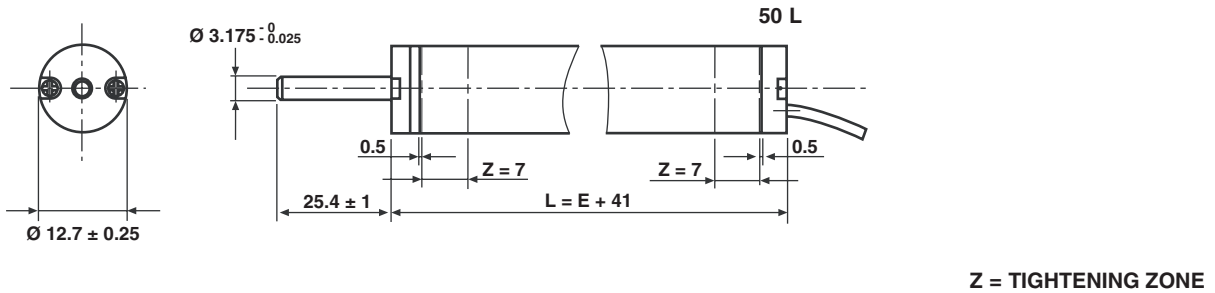

**ELECTRICAL CONNECTIONS**

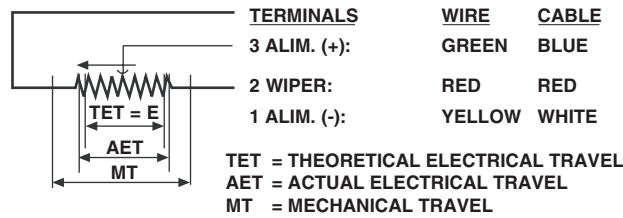

**ACCESSORIES ON REQUEST - DIMENSIONS** in millimeters, general tolerance  $\pm 3$  mm

Clamp for 50L  
Vishay Reference: CQ00050

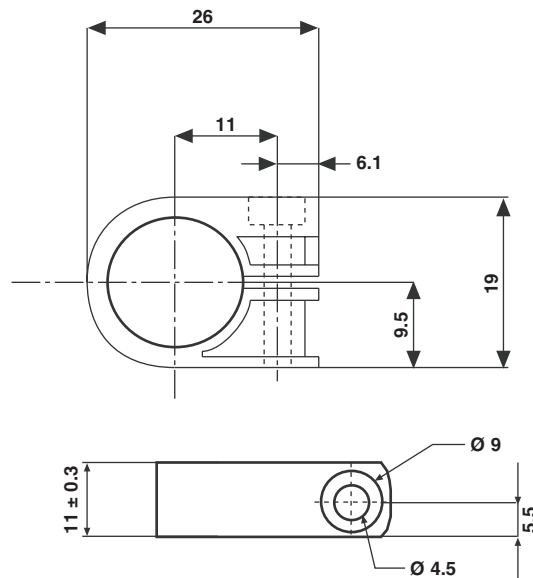

# Series REC 50 L

Vishay Sfernice

Precision Linear Transducers, Conductive Plastic,  
up to 300 mm



## OPTIONS - DIMENSIONS in millimeters

### OPTION 1: SEALED (IP65): W03242

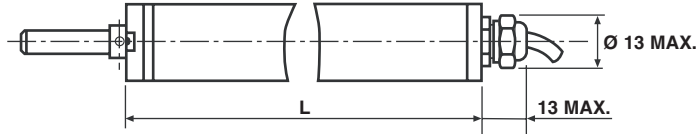

MODEL	CODE	L
50 L ...	W03242	TET + 70.5

### OPTION 2: SPRING LOADED SHAFT; OUTPUT BY SHIELDED CABLE: W01743

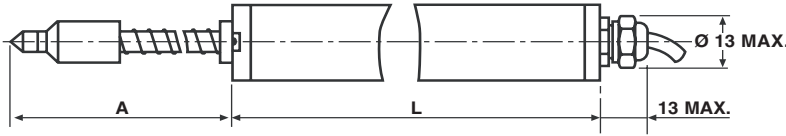

MODEL	CODE	A	L
50 L1	W01743	70	TET + 97.8
50 L2	W01743	116	
50 L3	W01743	162	
50 L4	W01743	208	

### OPTION 3: DOUBLE BALL JOINT: W01565

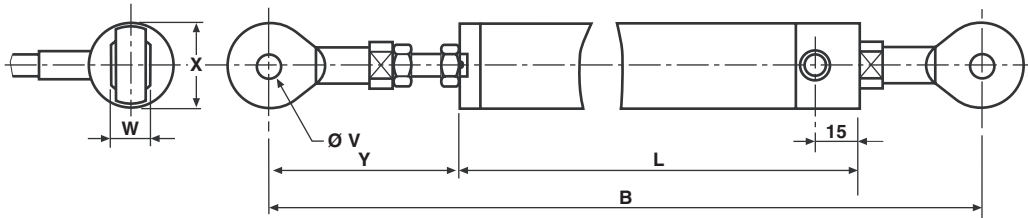

MODEL CODE	B	L	Ø V	W	X	Y	TET
50 L W01565 L1 to L3	TET + 108.5	TET + 57.5	3	6	12	30 ± 2	25 to 75
L4 to L6	TET + 133.5	TET + 82.5	3	6	12	30 ± 2	100 to 150

## ORDERING INFORMATION/DESCRIPTION

REC	50	L	3	D	103	W...	e1
SERIES	MODEL	NUMBER OF TRACKS	THEORETICAL ELECTRICAL	LINEARITY	OHMIC VALUE	MODIFICATIONS	LEAD FINISH
		L = 1 track LL = 2 tracks	Times 25 mm	A: ± 1 % D: ± 0.1 % E: ± 0.05 % F: ± 0.025 %	First 2 digits are significant numbers 3rd digit indicates number of zeros	Special feature code number	Sn Ag Cu

## SAP PART NUMBERING GUIDELINES

RE	50 L	3	D	103	W...
SERIES	MODEL	TET	LINEARITY	OHMIC VALUE	SPECIAL FEATURES



# Wirewound Technology

## Single Turn Models

### Contents

Model 100 .....	80
Model 122 .....	83
Model 132 .....	86
Model 140 .....	88
Model 142 .....	90
Model 152 .....	92
Model 172 .....	95
Model 182 .....	98
Model 202 .....	100
Model 302 .....	103
Model 402 .....	106
Model 452 .....	109
Model 702 .....	112

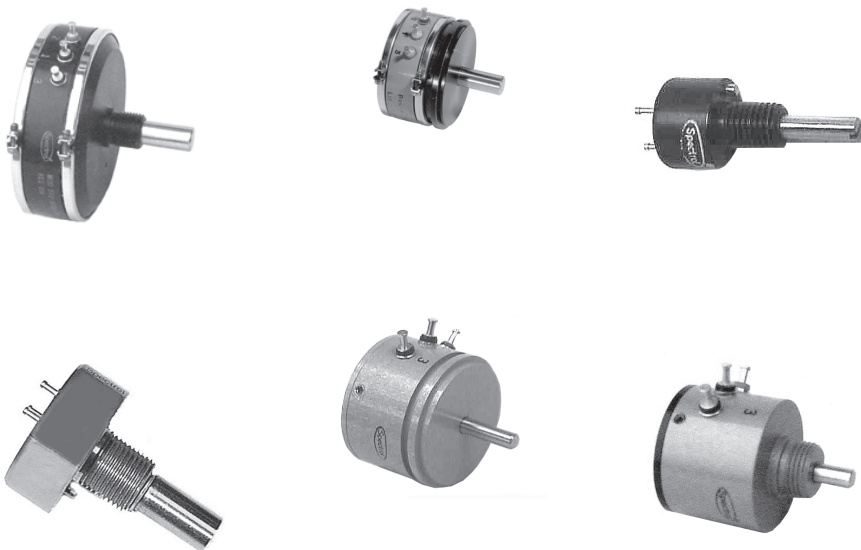

## 1 5/16" (33.3 mm) Single Turn Wirewound Precision Potentiometer



### FEATURES

- Gangable up to 6 sections
- Extra taps on request
- Bushing and servo mount types available
- Ohmic value range: 5 Ω up to 35 kΩ



**RoHS**  
COMPLIANT

ELECTRICAL SPECIFICATIONS		
PARAMETER		
Total Resistance: Tolerance: 50 Ω and Above Below 50 Ω	<b>STANDARD</b> 5 Ω to 20 kΩ ± 3 % ± 5 %	<b>SPECIAL</b> to 35 kΩ ± 1 % ± 3 %
End Voltage	Linearity x total applied voltage for total resistance above 20 Ω 2.0 % of total applied voltage for 20 Ω and below	
Linearity (Independent): 5 Ω to 100 Ω 100 Ω to 500 Ω 500 Ω to 3 kΩ 3 kΩ to 15 kΩ 15 kΩ and above	<b>STANDARD</b> ± 1.0 % ± 0.5 % ± 0.5 % ± 0.5 % ± 0.5 %	<b>BEST PRACTICAL</b> ± 0.50 % ± 0.35 % ± 0.25 % ± 0.20 % ± 0.15 %
Noise	100 Ω ENR (MIL-R-12934)	
Electrical Angle	352° ± 2°	
Power Rating	2.75 W at 40 °C ambient	
Insulation Resistance	100 MΩ min, 500 V <sub>DC</sub>	
Dielectric Strength	1000 V <sub>RMS</sub> , 60 Hz	
Taps (Extra)	Up to 13 (position tolerance: ± 1°)	
Phasing	CCW taps of multiple sections aligned with CCW tap of section 1 to ± 1°	
Absolute Minimum Resistance	Linearity x total resistance or 0.5 Ω, whichever is greater	

ORDERING INFORMATION/DESCRIPTION				
The Model 100 can be ordered from this data sheet with a variety of alternate characteristics, as shown. For most rapid service on your order, please state:				
<b>100</b>	<b>S</b>	<b>1</b>	<b>10K</b>	<b>BO1</b>
MODEL	MOUNTING TYPE	NUMBER OF SECTIONS	OHMIC VALUE	PACKAGING
	<b>B:</b> Bushing <b>S:</b> Servo	Up to 6 sections		Box of 1 piece
Other characteristics will be standard as described on this data sheet. If special characteristics are required, such as: special linearity tolerance, special resistance tolerance, extra taps, non-linear functions, etc., please state these on your order and allow additional lead time for delivery.				

SAP PART NUMBERING GUIDELINES					
<b>100</b>	<b>B</b>	<b>2</b>	<b>203</b>	<b>502</b>	<b>B01</b>
MODEL	STYLE	NUMBER OF SECTIONS	OHMIC VALUE	OHMIC VALUE	PACKAGING
	Bushing		Section N° 1: 20K	Section N° 2: 5K	Box of 1 piece



**DIMENSIONS** in inches (millimeters)

**BUSHING MOUNT: 100B...**

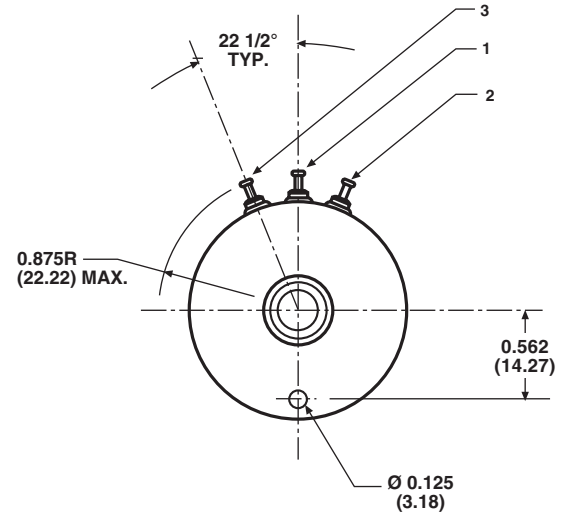
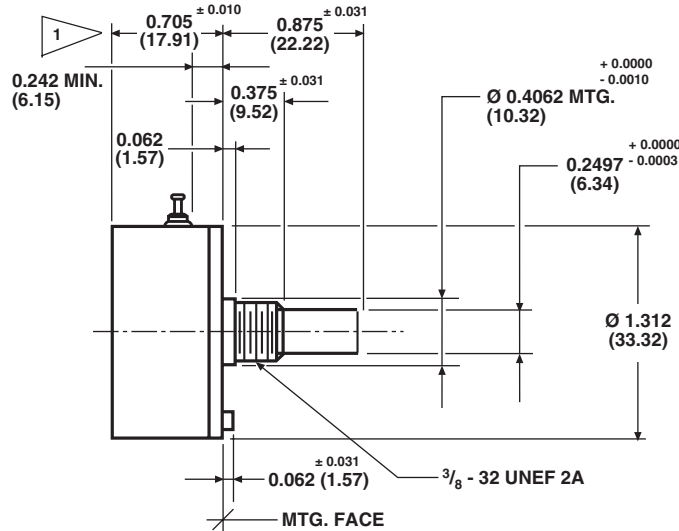

**SERVO MOUNT: 100S...**

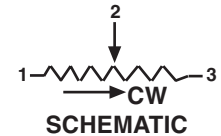
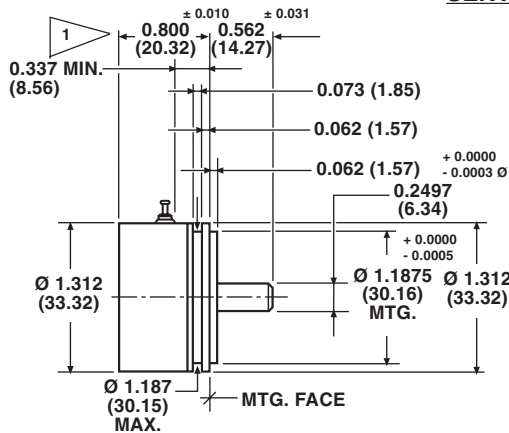

1 ADD 0.566 ± 0.002 (14.38) FOR EACH ADDITIONAL SECTION

TOLERANCES: UNLESS OTHERWISE NOTED.  
DECIMALS ± 0.005 ANGLES ± 2°

MECHANICAL SPECIFICATIONS		
PARAMETER		
Rotation	360° (continuous)	
Bearing Type	Servo mount: Ball bearing Bushing mount: Sleeve bearing	
Ganging	6 sections maximum, terminal alignment, added sections, within ± 10° of section 1 terminals	
Torque (Maximums)	<b>STARTING</b>	<b>RUNNING</b>
Servo, 1 Section	0.60 oz. - in (43.20 g - cm)	0.30 oz. - in (21.60 g - cm)
Bushing, 1 Section	1.00 oz. - in (72.00 g - cm)	0.75 oz. - in (54.00 g - cm)
Each Additional Section	0.30 oz. - in (21.60 g - cm)	0.30 oz. - in (21.60 g - cm)
Mechanical Tolerances (Maximums):	<b>BUSHING</b>	<b>SERVO</b>
Shaft Runout (TIR/In)	0.002" (0.05 cm)	0.002" (0.05 cm)
Pilot Dia. Runout (TIR)	0.002" (0.05 cm)	0.002" (0.05 cm)
Lateral Runout (TIR)	0.005" (0.13 cm)	0.002" (0.05 cm)
Shaft End Play	0.005" (0.13 cm)	0.005" (0.13 cm)
Shaft Radial Play	0.004" (0.10 cm)	0.002" (0.05 cm)
Moment of Inertia	1.0 g - cm <sup>2</sup> per section maximum	
Weight		
Single Section	2.0 oz. maximum (56.7 g)	
Each Additional Section	0.75 oz. maximum (21.3 g)	

# Model 100



Vishay Spectrol

1 5/16" (33.3 mm) Single Turn Wirewound  
Precision Potentiometer

MATERIAL SPECIFICATIONS	
Housing and Lids	Aluminum, anodized
Shaft	Stainless steel, non-magnetic non-passivated
Terminals	Brass, plated for solderability
Bushing Mount Hardware Lockwasher Internal Tooth: Panel Nut:	Steel, nickel plated Brass, nickel plated

ENVIRONMENTAL SPECIFICATIONS	
Vibration	15 g thru 2000 CPS
Shock	50 g
Salt Spray	96 h
Rotational Life	1 million shaft revolutions
Load Life	900 h
Temperature Range	- 55 °C to + 105 °C

MARKING	
Unit Identification	Units shall be marked with Vishay Spectrol name, model number and data code and on each section, resistance, resistance tolerance, linearity and terminal identification

## POWER RATING CHART

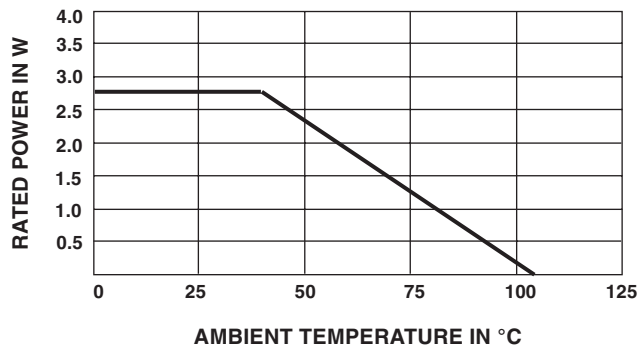

RESISTANCE ELEMENT DATA					
RESISTANCE VALUES (Ω)	RESOLUTION (%)	OHMS PER TURN	MAXIMUM CURRENT AT 70 °C AMBIENT (mA)	MAXIMUM VOLTAGE ACROSS COIL (V)	WIRE TEMP. COEF. (ppm/°C)
5	0.346	0.017	742	3.7	800
10	0.298	0.030	524	5.2	800
20	0.236	0.047	371	7.4	800
50	0.244	0.122	235	12	20
100	0.222	0.222	166	17	20
200	0.181	0.361	117	23	20
500	0.178	0.885	74	37	20
1K	0.138	1.38	52	52	20
2K	0.105	2.09	37	74	20
5K	0.085	4.23	23	117	20
10K	0.069	6.84	17	166	20
20K	0.058	11.5	12	235	20
35K	0.058	20.0	8.8	310	20

## 1 1/16" (27 mm) Single Turn Wirewound Precision Potentiometer

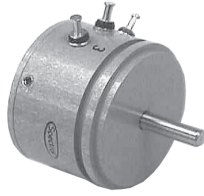

### FEATURES

- Gangable up to 6 sections
- Extra taps on request
- Bushing or servo mount types available
- Ohmic value range: 5 Ω up to 100 kΩ



**RoHS**  
COMPLIANT

ELECTRICAL SPECIFICATIONS		
PARAMETER	STANDARD	SPECIAL
Total Resistance Tolerance: 20 Ω and Above Below 20 Ω	5 Ω to 20 kΩ ± 3 % ± 5 %	to 100 kΩ ± 1 % ± 3 %
Linearity (Independent): 5 Ω to 200 Ω 200 Ω to 2 kΩ 2 kΩ to 10 kΩ 10 kΩ and Above	<b>STANDARD</b> ± 1.0 % ± 0.5 % ± 0.5 % ± 0.5 %	<b>BEST PRACTICAL</b> ± 0.50 % ± 0.35 % ± 0.25 % ± 0.20 %
Noise	100 Ω ENR	
Electrical Angle	350° ± 2°	
Power Rating Section 1: Additional Sections:	1.50 W at 70 °C ambient, derated to zero at 125 °C 75 % of the rating of section 1 (1.125 W at 70 °C)	
Insulation Resistance	1000 MΩ minimum 500 V <sub>DC</sub>	
Dielectric Strength	1000 V <sub>RMS</sub> 60 Hz	
Absolute Minimum Resistance	Linearity x total resistance or 0.5 Ω, whichever is greater	
End Voltage	Linearity x total applied voltage for total resistance above 20 Ω, 2.0 % of total applied voltage for 20 Ω and below	
Phasing (CCW End Points)	Additional sections phased to section 1 within ± 1°	
Taps (Extra)	9 available as special standard tolerance ± 1°	

ORDERING INFORMATION/DESCRIPTION				
The Model 122 can be ordered from this data sheet with a variety of alternate characteristics, as shown. For most rapid service on your order, please state:				
<b>122</b> MODEL	<b>B</b> MOUNTING TYPE	<b>1</b> NUMBER OF SECTIONS	<b>5K</b> TOTAL RESISTANCE OF EACH SECTION	<b>BO1</b> PACKAGING
	<b>B:</b> Bushing <b>S:</b> Servo	Up to 6 sections	Beginning with the section nearest the mounting end	Box of 1 piece
Other characteristics will be standard as described on this data sheet. If special characteristics are required, such as: special linearity tolerance, special resistance tolerance, extra taps, non-linear functions, etc., please state these on your order and allow additional lead time for delivery.				

SAP PART NUMBERING GUIDELINES					
<b>122</b> MODEL	<b>S</b> MOUNTING TYPE	<b>2</b> NUMBER OF SECTIONS	<b>103</b> OHMIC VALUE	<b>203</b> OHMIC VALUE	<b>BO1</b> PACKAGING
	Servo	2	Section N° 1 103 = 10K	Section N° 2 203 = 20K	Box of 1 piece



# Model 122



Vishay Spectrol

1 1/16" (27 mm) Single Turn Wirewound Precision Potentiometer

## DIMENSIONS in inches (millimeters)

### BUSHING MOUNT: 122B...

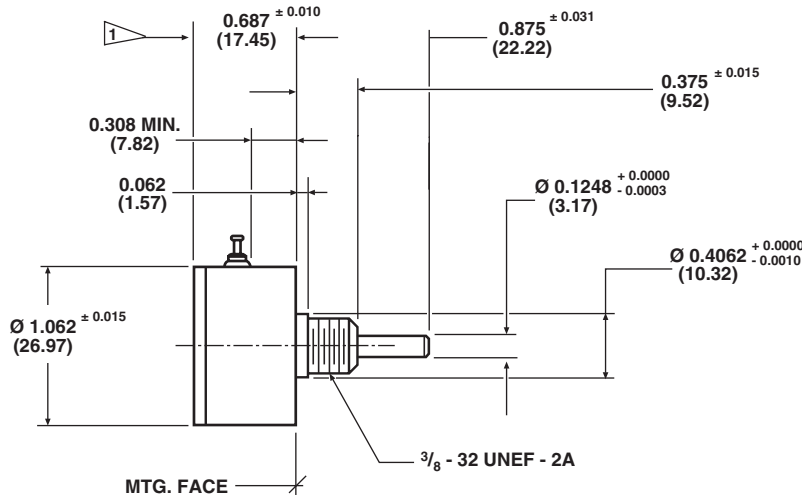

### SERVO MOUNT: 122S...

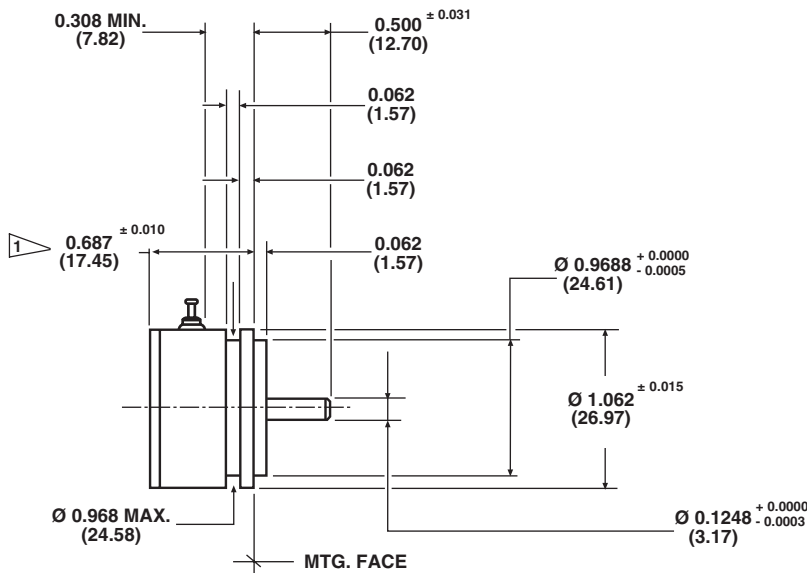

ADD 0.500 ± 0.002 (12.70) FOR EACH ADDITIONAL SECTION

TOLERANCES: UNLESS OTHERWISE NOTED.  
DECIMALS ± 0.005 ANGLES ± 2°

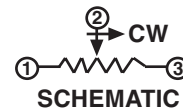

MATERIAL SPECIFICATIONS	
Housing and Lids	Aluminum, anodized
Shaft	Stainless steel, non-magnetic non-passivated
Terminals	Brass, plated for solderability
Bushing Mount Hardware Lockwasher Internal Tooth: Panel Nut:	Steel, nickel plated Brass, nickel plated

ENVIRONMENTAL SPECIFICATIONS	
Vibration	15 g thru 2000 CPS
Shock	50 g
Salt Spray	96 h
Rotational Life	1 million shaft revolutions
Load Life	900 h
Temperature Range	- 55 °C to + 125 °C

MARKING	
Unit Identification	Units shall be marked with Vishay Spectrol name and model number resistance and resistance tolerance, linearity, terminal identification and data code



**POWER RATING CHART**

(Ratings for cup No.1.  
Additional cups 75 % of values shown)

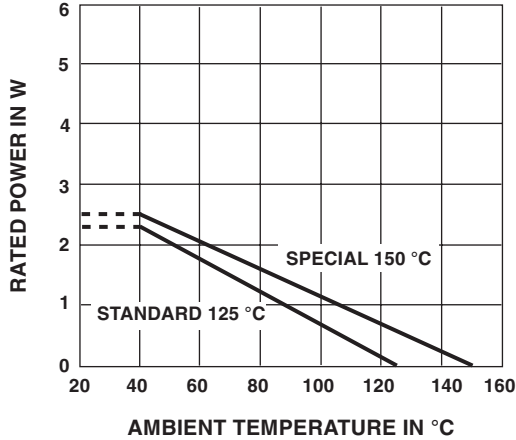

RESISTANCE ELEMENT DATA					
RESISTANCE VALUES (Ω)	RESOLUTION (%)	OHMS PER TURN	MAXIMUM CURRENT AT 70 °C AMBIENT (mA)	MAXIMUM VOLTAGE ACROSS COIL (V)	WIRE TEMP. COEF. (ppm/°C)
5	0.364	0.018	548	2.74	800
10	0.311	0.031	387	3.87	800
20	0.250	0.050	274	5.48	180
50	0.232	0.116	173	8.65	180
100	0.232	0.231	122	12.2	20
200	0.194	0.389	86.6	17.3	20
500	0.168	0.841	54.8	27.4	20
1K	0.156	1.557	38.7	38.7	20
2K	0.109	2.178	27.4	54.8	20
5K	0.088	4.382	17.3	86.5	20
10K	0.076	7.644	12.2	122	20
20K	0.071	14.235	8.66	173	20
50K	0.062	30.921	5.48	274	20
100K	0.052	51.983	3.87	387	20

MECHANICAL SPECIFICATIONS		
PARAMETER		
Rotation	360° continuous	
Bearing Type	Servo mount: Ball bearing Bushing mount: Sleeve bearing	
Torque (Maximums) Servo, 1 Section Bushing, 1 Section Each Additional Section	<b>STARTING</b> 0.25 oz. - in (18.0 g - cm) 0.30 oz. - in (21.6 g - cm) 0.20 oz. - in (14.4 g - cm)	<b>RUNNING</b> 0.15 oz. - in (10.8 g - cm) 0.25 oz. - in (18.0 g - cm) 0.15 oz. - in (10.8 g - cm)
Mechanical Runouts (Maximums): Shaft Runout (TIR/in) Pilot Dia. Runout (TIR) Lateral Runout (TIR) Shaft End Play Shaft Radial Play	<b>SERVO</b> 0.002" (0.05 cm) 0.002" (0.05 cm) 0.002" (0.05 cm) 0.005" (0.13 cm) 0.002" (0.05 cm)	<b>BUSHING</b> 0.002" (0.05 cm) 0.002" (0.05 cm) 0.005" (0.13 cm) 0.005" (0.13 cm) 0.003" (0.08 cm)
Weight (Maximums): Single Section Each Additional Section	0.8 oz. (22.7 g) 0.4 oz. (11.3 g)	
Ganging	6 sections maximum, terminal alignment, added sections within ± 10° of section 1 terminals	
Moment of Inertia	0.12 g - cm <sup>2</sup> per section maximum	

## 1 5/16" (33.3 mm) Low Cost Industrial Single Turn Wirewound, Bushing Mount Type



### FEATURES

- Suitable model for all industrial applications
- Center tap available
- Continuous rotation and mechanical stops both standard
- Large electrical angle:  $352^\circ \pm 2^\circ$



**RoHS**  
COMPLIANT

ELECTRICAL SPECIFICATIONS		
PARAMETER	MIL-PRF-12934 TEST PROCEDURES APPLY	
	STANDARD	SPECIAL
Total Resistance Tolerance: 50 $\Omega$ and Above Below 50 $\Omega$	5 $\Omega$ to 20 k $\Omega$ $\pm 3\%$ $\pm 5\%$	to 35 k $\Omega$ $\pm 1\%$ $\pm 3\%$
Linearity (Independent) Total Resistance 5 $\Omega$ to 20 $\Omega$ 20 $\Omega$ to 200 $\Omega$ 200 $\Omega$ and Above	<b>STANDARD</b>  $\pm 1.0\%$ $\pm 1.0\%$ $\pm 0.5\%$	<b>BEST PRACTICAL</b>  $\pm 0.75\%$ $\pm 0.50\%$ $\pm 0.25\%$
Noise	100 $\Omega$ ENR	
Power Rating	40 $^\circ\text{C}$ ambient 2.75 W derated to zero at 125 $^\circ\text{C}$	
Electrical Angle Continuous Rotation Stops	352 $^\circ \pm 2^\circ$ 340 $^\circ \pm 5^\circ$	
Insulation Resistance	1000 M $\Omega$ minimum at 500 V <sub>DC</sub>	
Dielectric Strength	1000 V <sub>RMS</sub> , 60 Hz	
Absolute Minimum Resistance	1.0 % of total resistance or 0.5 $\Omega$ whichever is greater	
Minimum Voltage	0.5 % maximum	
Temperature Coefficient of Resistance	Refer to standard resistance element data	

MATERIAL SPECIFICATIONS	
Housing	Molded glass filled thermoplastic
Rear Lid	Glass filled thermoset plastic
Shaft	Stainless steel, non-magnetic
Terminals	Brass, plated for solderability, Non-passivated
Mount Hardware Lockwasher Internal Tooth: Panel Nut:	Steel, nickel plated Brass, nickel plated

ENVIRONMENTAL SPECIFICATIONS	
Vibration	15 Gs thru 2000 Hz
Shock	50 g
Salt Spray	48 h
Rotational Life Shaft Revolutions	500 000
Operating Temperature Range	- 55 $^\circ\text{C}$ to + 125 $^\circ\text{C}$

ORDERING INFORMATION/DESCRIPTION				
132	0	0	20K	B010
MODEL	MECHANICAL OPTIONS	OTHER OPTIONAL FEATURES	OHMIC VALUE	PACKAGING
	0. Continuous 2. Stops	0. Standard (end taps) 1. Center tap (within 5 $^\circ$ of electrical center)		Box of 10 pieces
Other characteristics will be standard as described on this specification sheet. If special characteristics are required such as special linearity tolerance, special resistance tolerance, non-linear functions, etc., please state these on your order.				

SAP PART NUMBERING GUIDELINES				
132	2	1	103	B10
MODEL	MECHANICAL OPTIONS	ELECTRICAL OPTIONS	OHMIC VALUE	PACKAGING
	2: With stops	1: With center tap	103: 10K	Box of 10 pieces



1 5/16" (33.3 mm) Low Cost Industrial Single Turn Vishay Spectrol Wirewound, Bushing Mount Type

**DIMENSIONS** in inches (millimeters)

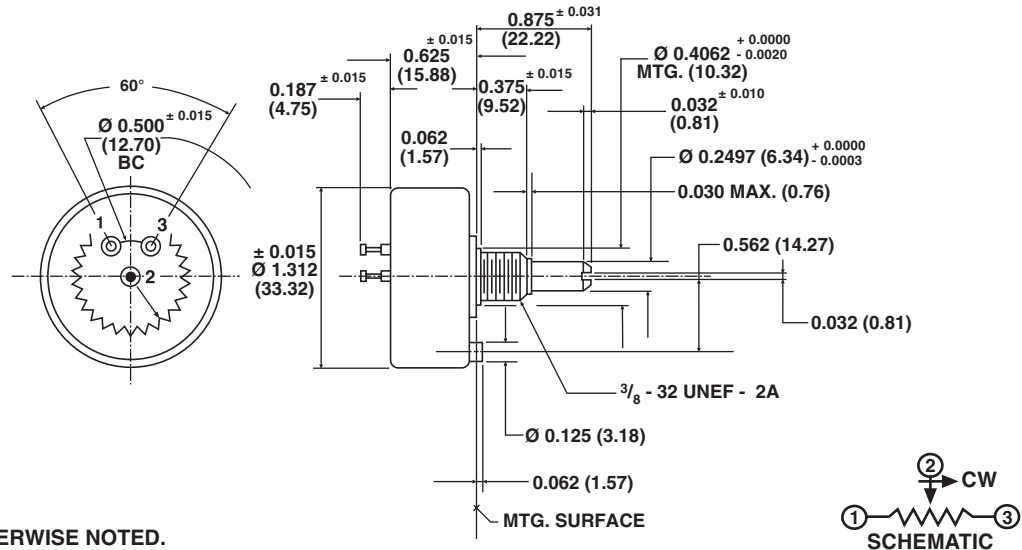

TOLERANCES: UNLESS OTHERWISE NOTED.  
DECIMALS ± 0.005 ANGLES ± 2°

MECHANICAL SPECIFICATIONS		
PARAMETER		
Rotation	360° (continuous) or 340° ± 5° (stops)	
Bearing Type	Sleeve	
Torque (Maximums)	<b>STARTING</b> 1.0 oz. - in (72 g - cm)	<b>RUNNING</b> 0.7 oz.- in (50.40 g - cm)
Runouts (Maximums)		
Shaft Runout (TIR)	0.002" (0.05 mm)	
Pilot Dia. Runout (TIR)	0.003" (0.08 mm)	
Lateral Runout (TIR)	0.005" (0.13 mm)	
Shaft End Play	0.008" (0.20 mm)	
Shaft Radial Play	0.003" (0.08 mm)	
Weight	1.0 oz. maximum (28.35 g)	
Stop Strength	8.0 in - lbs (9.21 kg - cm) (stops version only)	

**POWER RATING CHART**

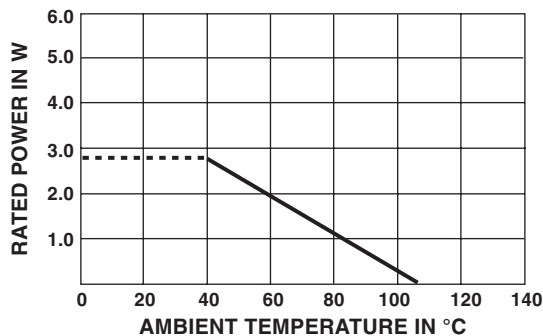

**RESISTANCE ELEMENT DATA**

RESISTANCE VALUES (Ω)	RESOLUTION (%)	OHMS PER TURN	MAXIMUM CURRENT AT 40 °C AMBIENT (mA)	MAXIMUM VOLTAGE ACROSS COIL (V)	WIRE TEMP. COEF. (ppm/°C)
5	0.419	0.021	742	3.71	800
10	0.327	0.032	524	5.24	800
20	0.280	0.056	371	7.42	800
50	0.290	0.145	234	11.7	20
100	0.251	0.251	166	16.6	20
200	0.212	0.424	122	24.4	20
500	0.161	0.806	74.2	37.1	20
1K	0.150	1.50	52.4	52.4	20
2K	0.132	2.64	37.1	74.2	20
5K	0.107	5.34	23.4	117	20
10K	0.080	7.98	16.6	166	20
20K	0.067	13.4	12.2	244	20
35K	0.057	20.0	8.88	311	20

MARKING	
Unit Identification	Units shall be marked with Vishay Spectrol name, model number, resistance and tolerance, linearity, terminal identification, and data code Applicable test procedures: MIL-R-12934

## 1/2" (12.7 mm) Single - Turn Wirewound Bushing Mount Type Precision Potentiometer



### FEATURES

- Ohmic value range: 50 Ω up to 20 kΩ
- Smallest size available: 12.7 mm
- Mechanical stops on request
- High torque and sealed versions available



**RoHS**  
COMPLIANT

ELECTRICAL SPECIFICATIONS	
PARAMETER	
Total Resistance	50 Ω to 20 kΩ
Tolerance	± 5 %
Absolute Minimum Resistance	Linearity x total resistance or 0.5 Ω, whichever is greater
Linearity (Independent)	± 1.0 %
Noise	100 Ω ENR
Power Rating	2 W at 40 °C ambient derating linearly to zero at 125 °C
Insulation Resistance	1000 MΩ min. 500 V <sub>DC</sub>
Dielectric Strength	1000 V <sub>RMS</sub> , 60 Hz
Electrical Angle	320° ± 5°
End Voltage	Linearity x total applied voltage for total resistance above 20 Ω; 2.0 % of total applied voltage for 20 Ω and below

MATERIAL SPECIFICATIONS	
Shaft	Stainless steel, non magnetic non-passivated
Housing	Aluminum, anodized
Rear Lid	Molded glass filled thermoset plastic
Terminals	Brass, gold plated
Mounting Hardware Lockwasher Internal Tooth: Panel Nut:	Steel, nickel plated. Brass, nickel plated

ENVIRONMENTAL SPECIFICATIONS	
Vibration	20 G thru 2000 Hz
Shock	50 g
Salt Spray	96 h
Rotational Life	500 000 shaft revolutions
Load Life	900 h
Temperature Range	- 55 °C to + 125 °C (operating)

ORDERING INFORMATION/DESCRIPTION				
140B	0	0	20K	BO10
MODEL	MECHANICAL OPTIONS	SPECIAL FEATURE	OHMIC VALUE	PACKAGING
	0. Stops, slotted shaft (std) 1. Plain shaft 2. Shaft lock 3. Continuous rotation 4. Combination 1 and 2 5. Combination 1 and 3 6. Combination 2 and 3 7. Combination 1, 2 and 3	0. Standard torque 1. Center tap (10K max. Rt) 2. High torque 3. Sealed construction 4. Combination 1 and 2 5. Combination 1 and 3 6. Combination 2 and 3 7. Combination 1, 2 and 3		Box of 10 pieces

SAP PART NUMBERING GUIDELINES				
140B	7	0	103	B10
MODEL	MECHANICAL OPTION	FEATURE	OHMIC VALUE	PACKAGING
	From 0 to 7	From 0 to 7	103 = 10K	Box of 10 pieces

# 1/2" (12.7 mm) Single - Turn Wirewound Bushing Mount Type Precision Potentiometer

Vishay Spectrol

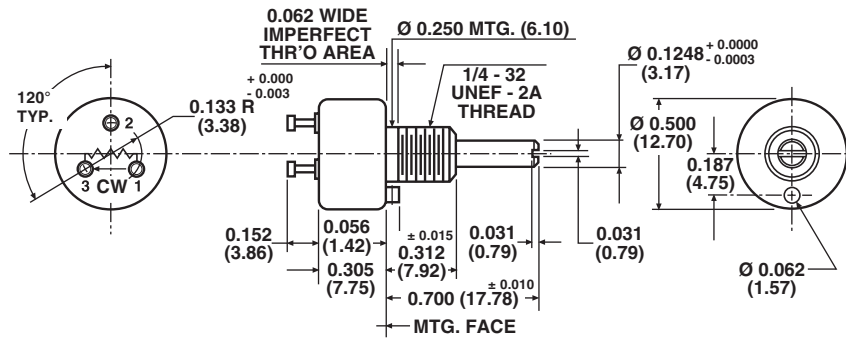
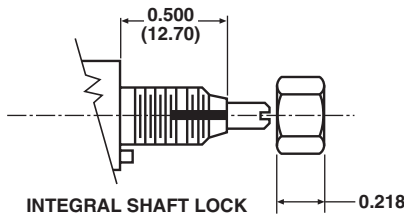
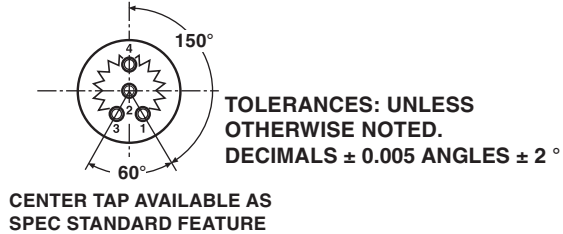
**DIMENSIONS** in inches (millimeters)

**SHAFT LOCK OPTION**

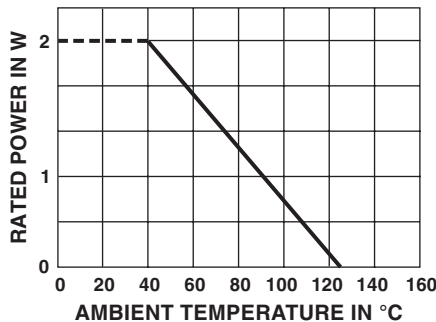
**CENTER TAP OPTION**

**MECHANICAL SPECIFICATIONS**

PARAMETER	
Rotation	330° ± 5°
Bearing Type	<b>SLEEVE BEARING</b>
Torque (Maximums)	
Starting	0.2 oz. - in (14.40 g - cm)
Running	0.2 oz. - in (14.40 g - cm)
Dead Zone	Not applicable
Weight	0.1 oz. maximum (2.84 g)
Stop Strength	5 in - lbs (5.76 kg - cm) static
Runouts (Maximum)	
Shaft (TIR)	0.002" (0.05 cm)
Pilot Dia. (TIR)	0.002" (0.05 cm)
Lateral (TIR)	0.003" (0.08 cm)
Shaft End Play	0.006" (0.15 cm)
Shaft Radial Play	0.003" (0.08 cm)

**POWER RATING CHART**

**RESISTANCE ELEMENT DATA**

STD RESISTANCE VALUES (Ω)	RESOLUTION (%)	OHMS PER TURN	MAXIMUM CURRENT AT 40 °C AMBIENT (mA)	MAXIMUM VOLTAGE ACROSS COIL (V)	WIRE TEMP. COEF. (ppm/°C)
50	0.542	0.271	200.0	10.0	20
100	0.431	0.431	141.0	14.1	20
200	0.361	0.722	100.0	20.0	20
500	0.312	1.56	63.2	31.6	20
1K	0.255	2.55	44.7	44.7	20
2K	0.197	3.94	31.6	63.2	20
5K	0.170	8.50	20.0	100.0	20
10K	0.147	14.7	14.1	141.0	20
20K	0.105	21.0	10.0	200.0	20

**MARKING**

Unit Identification	Units shall be marked with manufacturer's name, model number, resistance value and tolerance, circuit diagram, terminal identification, linearity and data code.
---------------------	--

## 1/2" (12.7 mm) Single - Turn Wirewound Servo Mount Type Precision Potentiometer



### FEATURES

- Ohmic value range: 50 Ω up to 20 kΩ
- Smallest size available: 12.7 mm
- Center tap on request
- Custom shafts available on request



ELECTRICAL SPECIFICATIONS	
PARAMETER	
Total Resistance	50 Ω to 20 kΩ
Tolerance	± 5 %
Absolute Minimum Resistance	Linearity x total resistance or 0.5 Ω, whichever is greater
Linearity (Independent)	± 1.0 %
Noise	100 Ω ENR
Power Rating	2 W at 40 °C ambient derating linearly to zero at 125 °C
Insulation Resistance	1000 MΩ min. 500 V <sub>DC</sub>
Dielectric Strength	1000 V <sub>RMS</sub> , 60 Hz
Electrical Angle	350° + 0° - 4°
End Voltage	Linearity x total applied voltage for total resistance above 20 Ω; 2.0 % of total applied voltage for 20 Ω and below

MATERIAL SPECIFICATIONS	
Shaft	Stainless steel, non magnetic non-passivated
Housing	Aluminum, anodized
Rear Lid	Molded glass filled thermoset plastic
Terminals	Brass, gold plated

ENVIRONMENTAL SPECIFICATIONS	
Vibration	20 G thru 2000 Hz
Shock	50 g
Salt Spray	96 h
Rotational Life	500 000 shaft revolutions
Load Life	900 h
Temperature Range	- 55 °C to + 125 °C (operating)

ORDERING INFORMATION/DESCRIPTION				
142S	0	0	10K	BO10
MODEL	MECHANICAL OPTIONS	SPECIAL FEATURE	OHMIC VALUE	PACKAGING
	0. Continuous rotation, plain shaft (std.)	0. Standard torque 1. Center tap (10K max. Rt)		Box of 10 pieces

SAP PART NUMBERING GUIDELINES				
142S	0	1	502	B10
MODEL	MECHANICAL OPTIONS	SPECIAL FEATURE	OHMIC VALUE	PACKAGING
		1: With center tap	502 = 5K	Box of 10 pieces



**1/2" (12.7 mm) Single - Turn Wirewound  
Servo Mount Type Precision Potentiometer**

Vishay Spectrol

**DIMENSIONS** in inches (millimeters)

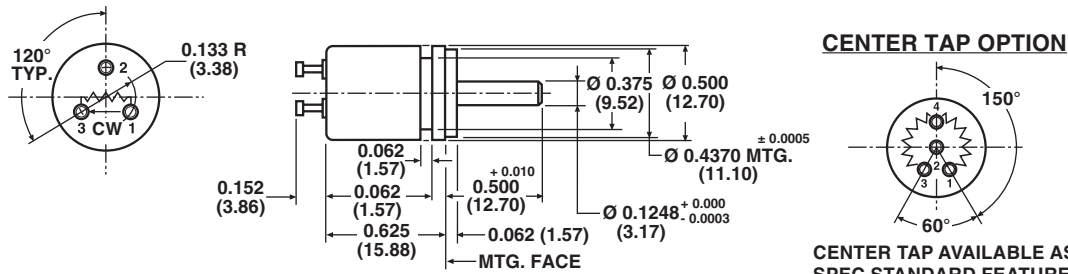

**CENTER TAP OPTION**

CENTER TAP AVAILABLE AS SPEC STANDARD FEATURE

**TOLERANCES: UNLESS OTHERWISE NOTED.  
DECIMALS ± 0.005 ANGLES ± 2°**

<b>MECHANICAL SPECIFICATIONS</b>	
PARAMETER	
Rotation	360° continuous
Bearing Type	<b>BALL BEARING</b>
Torque (Maximums)	
Starting	0.075 oz. - in (5.40 g - cm)
Running	0.05 oz. - in (3.60 g - cm)
Dead Zone	0.20 oz. - in (14.40 g - cm)
Weight	0.3 oz. (8.50 g) maximum
Runouts (Maximum)	0.002" (0.05 cm)
Shaft (TIR)	0.002" (0.05 cm)
Pilot Dia. (TIR)	0.002" (0.05 cm)
Lateral (TIR)	0.004" (0.10 cm)
Shaft End Play	0.002" (0.05 cm)
Shaft Radial Play	0.002" (0.05 cm)

**POWER RATING CHART**

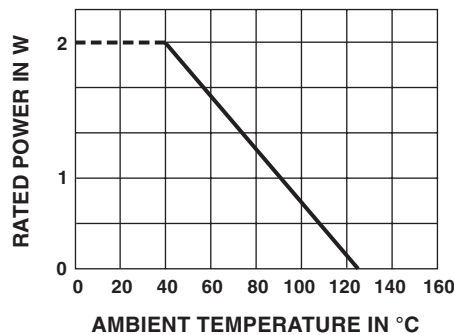

<b>RESISTANCE ELEMENT DATA</b>					
STD RESISTANCE VALUES (Ω)	RESOLUTION (%)	OHMS PER TURN	MAXIMUM CURRENT AT 40 °C AMBIENT (mA)	MAXIMUM VOLTAGE ACROSS COIL (V)	WIRE TEMP. COEF. (ppm/°C)
50	0.542	0.271	200.0	10.0	20
100	0.431	0.431	141.0	14.1	20
200	0.361	0.722	100.0	20.0	20
500	0.312	1.56	63.2	31.6	20
1K	0.255	2.55	44.7	44.7	20
2K	0.197	3.94	31.6	63.2	20
5K	0.170	8.50	20.0	100.0	20
10K	0.147	14.7	14.1	141.0	20
20K	0.105	21.0	10.0	200.0	20

<b>MARKING</b>	
<b>Unit Identification</b>	Units shall be marked with manufacturer's name, model number, resistance value and tolerance, circuit diagram, terminal identification, linearity and data code



## 7/8" (22.2 mm) Single Turn Wirewound, Precision Potentiometer

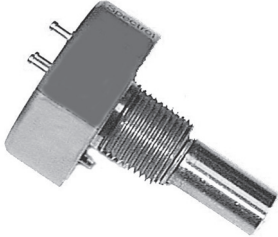

### FEATURES

- Rugged, high-quality, all metal housing
- Short length behind panel 1<sup>1</sup>/<sub>32</sub>" (8.76 mm)
- Ohmic value range: 5 Ω to 40 kΩ
- Extra taps available
- Bushing and servo mount types



**RoHS**  
COMPLIANT

ELECTRICAL SPECIFICATIONS		
PARAMETER		
Total Resistance Standard Range	5 Ω to 20 kΩ - special to 40 kΩ	
Tolerance 50 Ω and Above: Below 50 Ω	<b>STANDARD</b> ± 3 % ± 5 %	<b>SPECIAL</b> ± 1 % ± 3 %
Linearity (Independent) Total Resistance 5 Ω to 100 Ω 100 Ω to 500 Ω 500 Ω and Above	<b>STANDARD</b> ± 1.0 % ± 1.0 % ± 0.5 %	<b>BEST PRACTICAL</b> ± 0.75 % ± 0.50 % ± 0.35 %
Noise	100 Ω ENR	
Power Rating (at 40 °C Ambient)	2 W derated to zero at 125 °C	
Electrical Angle	340° ± 2°	
Insulation Resistance	1000 MΩ minimum 500 V <sub>DC</sub>	
Dielectric Strength	1000 V <sub>RMS</sub> , 60 Hz	
Absolute Minimum Resistance	Not to exceed linearity times total resistance or 0.5 Ω whichever is greater	
Minimum Voltage	0.5 % max.	
Temperature Coefficient of Resistance	Refer to standard resistance element data	

ORDERING INFORMATION/DESCRIPTION			
<b>152</b>	<b>S</b>	<b>10K</b>	<b>BO10</b>
MODEL	MOUNTING	OHMIC VALUE	PACKAGING
	<b>B:</b> Bushing <b>S:</b> Servo		Box of 10 pieces
Other characteristics will be standard as described on this data sheet. If special characteristics are required, such as: special linearity, special resistance tolerance, high torque, 1/8 shaft - 1/4 - 32 bushing, stops, non - linear functions, etc., state these on your order.			

SAP PART NUMBERING GUIDELINES			
<b>152</b>	<b>B</b>	<b>502</b>	<b>B10</b>
MODEL	MOUNTING TYPE	OHMIC VALUE	PACKAGING
	<b>B:</b> Bushing	502 = 5K	Box of 10 pieces

### DIMENSIONS in inches (millimeters)

#### BUSHING MOUNT TYPE: 152B

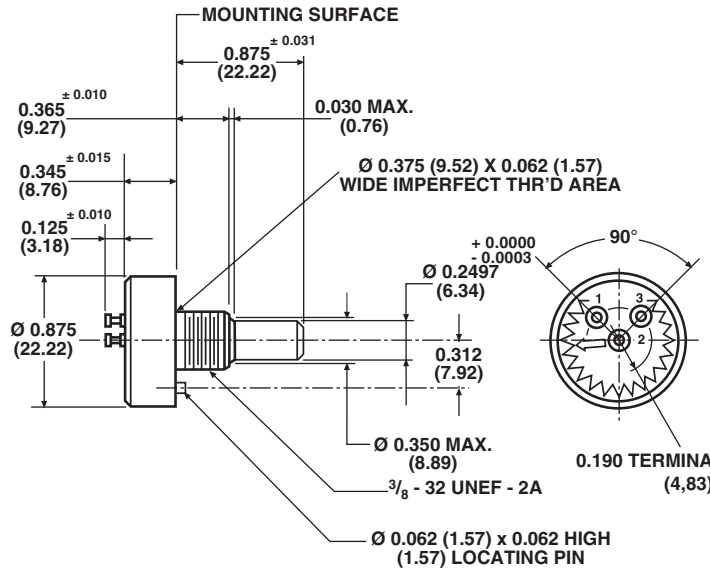

#### SERVO MOUNT TYPE: 152S

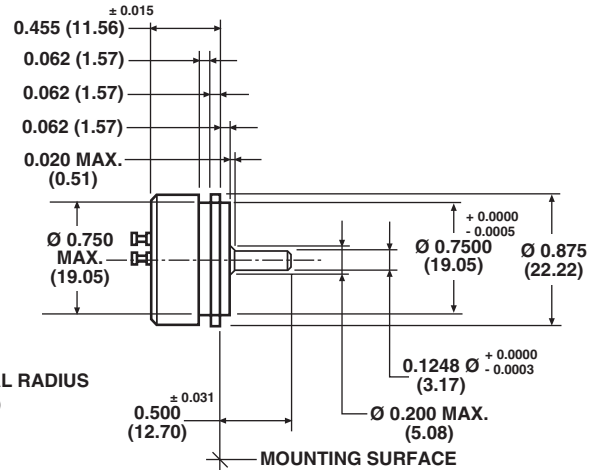

TOLERANCES: UNLESS OTHERWISE NOTED.  
DECIMALS ± 0.005 ANGLES ± 2°

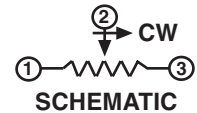

MECHANICAL SPECIFICATIONS		
PARAMETER		
Rotation	360° continuous	
Bearing Type	Servo mount: Ball bearing Bushing mount: Sleeve bearing	
Torque (Maximums)	<b>STARTING</b>	<b>RUNNING</b>
Servo	0.25 oz. - in (18.00 g - cm)	0.15 oz. - in (10.80 g - cm)
Bushing	0.30 oz. - in (21.60 g - cm)	0.25 oz. - in (18.00 g - cm)
Mechanical Runouts (Maximums)	<b>BUSHING</b>	<b>SERVO</b>
Shaft Runout	0.002" (0.05 cm)	0.002" (0.05 cm)
Pilot Dia. Runout	-	0.002" (0.05 cm)
Lateral Runout	0.005" (0.13 cm)	0.002" (0.05 cm)
Shaft End Play	0.006" (0.15 cm)	0.005" (0.13 cm)
Shaft Radial Play	0.003" (0.08 cm)	0.002" (0.05 cm)
Weight	0.5 oz. maximum (14.18 g)	

# Model 152



Vishay Spectrol

7/8" (22.2 mm) Single Turn Wirewound,  
Precision Potentiometer

MATERIAL SPECIFICATIONS	
Housing	Aluminum, anodized
Shaft	Stainless steel, non-magnetic non-passivated
Rear Lid	Molded glass filled phenolic
Terminals	Brass, plated for solderability
Bushing Mount Hardware Lockwasher Internal Tooth: Panel Nut:	Steel, nickel plated Brass, nickel plated

ENVIRONMENTAL SPECIFICATIONS		
Vibration	15 g thru 2000 Hz	
Shock	50 g	
Salt Spray	96 h	
Rotational Life Shaft Revolution:	<b>Bushing</b> 1 million	<b>Servo</b> 2 million
Load Life	900 h	
Operating Temperature Range	- 55 °C to - + 125 °C	

## POWER RATING CHART

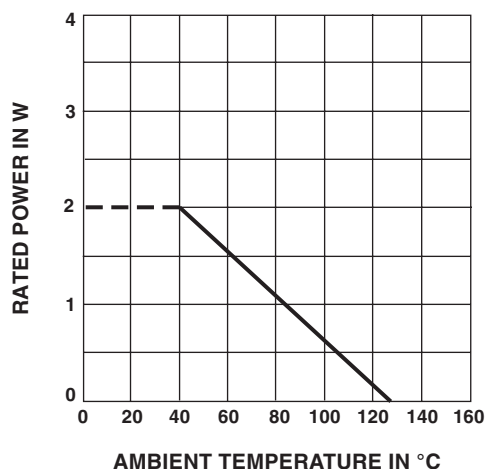

MARKING	
Unit Identification	Units shall be marked with Vishay Spectrol name, model number, resistance and tolerance, linearity terminal identification and data code. Applicable test procedures: MIL-R-12934



## 1 7/16" (36.5 mm) Single Turn Wirewound Precision Potentiometer



This Model 172 is only for maintenance purposes. It is not recommended for new designs and will be obsolete in a near future.

### FEATURES

- Bushing or servo mount types available
- Large ohmic value range: 5 Ω up to 40 kΩ
- Gangable up to 6 sections
- Extra taps on request

ELECTRICAL SPECIFICATIONS		
PARAMETER		
Total Resistance Tolerance: 50 Ω and Above Below 50 Ω	<b>STANDARD</b> 5 Ω to 40 kΩ ± 3 % ± 5 %	<b>SPECIAL</b> - ± 1 % ± 3 %
Absolute Minimum Resistance	Linearity x total resistance or 0.5 Ω, whichever is greater	
End Voltage	Linearity x total applied voltage for total resistance above 20 Ω, 2.0 % of total applied voltage for 20 Ω and below	
Linearity (Independent) 5 Ω to 200 Ω 200 Ω to 2 kΩ 3 kΩ and Above	<b>STANDARD</b> ± 0.30 %	<b>BEST PRACTICAL</b> ± 0.15 %
Noise	100 Ω ENR	
Electrical Angle	350° ± 2°	
Power Rating Section 1: 2.0 W Additional Sections	70 °C ambient derated to zero at 125 °C 75 % of rating of section 1 (1.5 W at 70 °C)	
Insulation Resistance	1000 MΩ minimum, 500 V <sub>DC</sub>	
Dielectric Strength	1000 V <sub>RMS</sub> , 60 Hz	
Taps (Extra)	15 available as special, standard tolerance ± 1°	
Phasing (CCW End Points)	Additional sections phased to section 1 within ± 1°	

ORDERING INFORMATION/DESCRIPTION					
The Model 172 can be ordered from this data sheet with a variety of alternate characteristics, as shown above. For most rapid service on your order, please state:					
<b>172</b>	<b>B</b>	<b>2</b>	<b>10K</b>	<b>5K</b>	<b>BO50</b>
MODEL	MOUNTING TYPE	NUMBER OF SECTIONS	OHMIC VALUE	OHMIC VALUE	PACKAGING
	<b>B:</b> Bushing <b>S:</b> Servo	Up to 6 sections (max.)	Section N° 1	Section N° 2	Box of 50 pieces
Other characteristics will be standard as described on this data sheet. If special characteristics are required, such as: special linearity tolerance, special resistance tolerance, extra taps, non-linear functions, etc., please state these on your order and allow additional lead time for delivery.					

SAP PART NUMBERING GUIDELINES				
<b>172</b>	<b>S</b>	<b>1</b>	<b>102</b>	<b>B25</b>
MODEL	STYLE	NUMBER OF SECTIONS	OHMIC VALUE	PACKAGING
	<b>S:</b> Servo		102 = 1 kΩ	Box of 50 pieces

**Model 172**

Vishay Spectrol

1 7/16" (36.5 mm) Single Turn Wirewound  
Precision Potentiometer

**DIMENSIONS** in inches (millimeters)

**SERVO MOUNT: 172S**

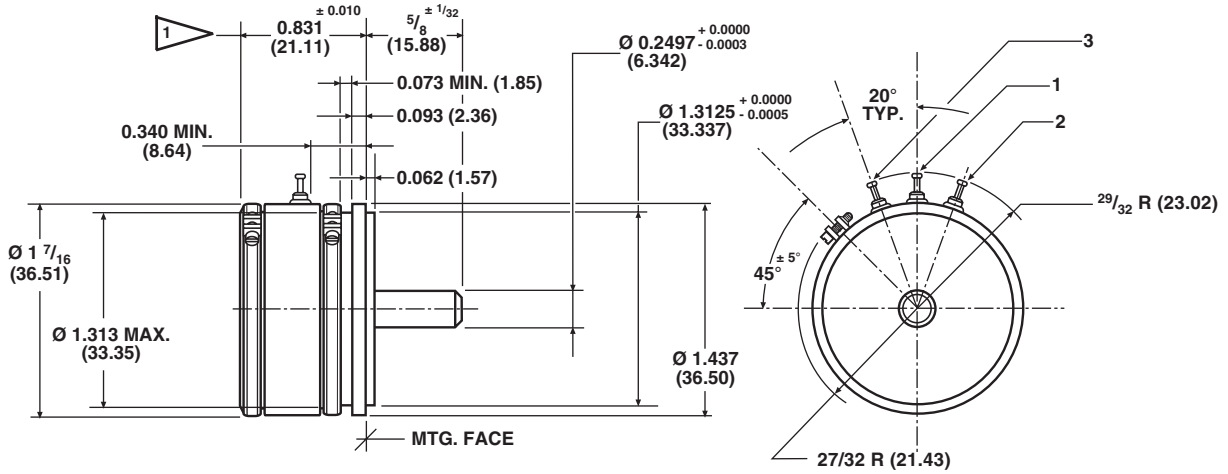

**BUSHING MOUNT: 172B**

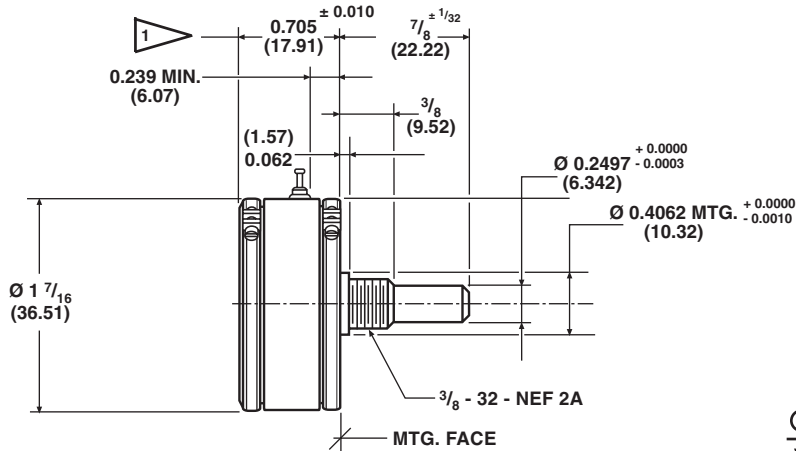

**1** ADD  $0.500 \pm 0.002$  (12.70) FOR EACH ADDITIONAL SECTION  
DECIMALS + 0.005 ANGLES +  $2^\circ$



<b>MECHANICAL SPECIFICATIONS</b>		
PARAMETER		
Mechanical Rotation	360° (continuous)	
Bearing Type	Servo mount: Ball bearing Bushing mount: Sleeve bearing	
Ganging	6 sections maximum, terminal alignment, added sections, within $\pm 10^\circ$ of section 1 terminals	
Torque (Maximums)	<b>STARTING</b>	<b>RUNNING</b>
Servo, Section 1	0.60 oz. - in (43.20 g - cm)	0.35 oz. - in (25.20 g - cm)
Bushing, Section 1	0.80 oz. - in (57.60 g - cm)	0.55 oz. - in (39.60 g - cm)
Each Additional Section	0.35 oz. - in (25.20 g - cm)	0.30 oz. - in (21.60 g - cm)
Mechanical Runouts (Maximums):	<b>BUSHING</b>	<b>SERVO</b>
Shaft Runout (TIR)	0.002" (0.05 cm)	0.002" (0.05 cm)
Pilot Dia. Runout (TIR)	0.002" (0.05 cm)	0.002" (0.05 cm)
Lateral Runout (TIR)	0.002" (0.05 cm)	0.002" (0.05 cm)
Shaft End Play	0.005" (0.13 cm)	0.005" (0.13 cm)
Shaft Radial Play	0.002" (0.05 cm)	0.004" (0.10 cm)
Moment of Inertia	2.0 g - cm <sup>2</sup> per section maximum	
Weight (Maximums)		
Single Section	2.5 oz. (70.90 g) maximum	
Each Additional Section	1.4 oz. (39.70 g) maximum	



1 7/16" (36.5 mm) Single Turn Wirewound  
Precision Potentiometer

Vishay Spectrol

MATERIAL SPECIFICATIONS	
Housing and Lids	Aluminum, anodized
Shaft and Clamp Rings	Stainless steel, non-magnetic non-passivated
Bushing Mount Hardware Lockwasher Internal Tooth: Panel Nut:	Steel, nickel plated Brass, nickel plated
Terminals	Brass plated

ENVIRONMENTAL SPECIFICATIONS	
Vibration	15 g thru 2000 Hz
Shock	50 g
Salt Spray	96 h
Rotational Life	1 million shaft revolutions
Load Life	900 h
Operating Temperature	- 65 °C to + 125 °C
Humidity Cycling	120 h

MARKING	
Unit Identification	Units shall be marked with Mfr. name, model no and date code, and on each section: resistance and tolerance, linearity, and terminal identification

**POWER RATING CHART**

(Ratings for cup No. 1.  
Additional cups 75 % of values shown)

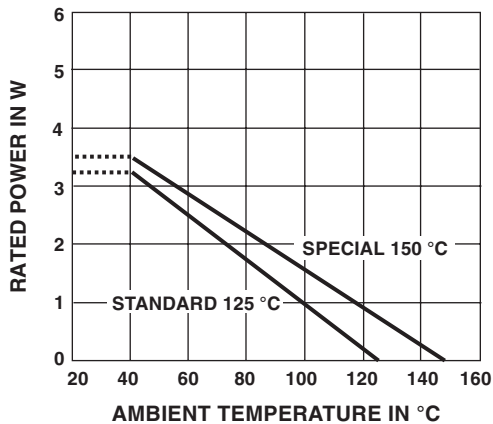

RESISTANCE ELEMENT DATA					
STANDARD RESISTANCE VALUES (Ω)	RESOLUTION (%)	OHMS PER TURN	MAXIMUM CURRENT AT 40 °C AMBIENT (mA)	MAXIMUM VOLTAGE ACROSS COIL (V)	WIRE TEMP. COEF. (ppm/°C)
5	0.340	0.017	632	3.16	800
10	0.290	0.029	447	4.47	800
20	0.235	0.047	315	6.32	800
50	0.244	0.122	200	10.0	20
100	0.221	0.221	141	14.1	20
200	0.180	0.360	100	20.0	20
500	0.141	0.706	63.2	31.6	20
1K	0.130	1.300	44.7	44.7	20
2K	0.104	2.091	31.6	63.2	20
5K	0.085	4.253	20.0	100	20
10K	0.066	6.603	14.1	141	20
20K	0.057	11.498	10.0	200	20

## 3/4" (19 mm) Single Turn Wirewound Servo Mount Precision Potentiometer



This Model 182 is only for maintenance purposes. It is not recommended for new designs and will be obsolete in a near future.

### FEATURES

- Gangable up to 6 sections
- Large range of ohmic values: 5 Ω to 30 kΩ
- Extra taps upon request



ELECTRICAL SPECIFICATIONS		
PARAMETER	STANDARD	SPECIAL
Total Resistance Tolerance: 20 Ω and Above Below 20 Ω	5 Ω to 30 kΩ ± 3 % ± 5 %	- ± 1 % ± 3 %
Absolute Minimum Resistance	Linearity x total resistance or 0.5 Ω, whichever is greater	
End Voltage	Linearity x total applied voltage for total resistance above 20 Ω, 2.0 % of total applied voltage for 20 Ω and below	
Linearity (Independent) 5 Ω to 2 kΩ 2 kΩ and Above	± 1.0 % ± 0.5 %	
Noise	100 Ω ENR	
Electrical Angle	350° ± 2°	
Power Rating: Section 1: 1.5 W Additional Sections	70 °C ambient derated to zero at 155 °C 75 % of the rating of section 1	
Insulation Resistance	1000 MΩ minimum, 500 V <sub>DC</sub>	
Dielectric Strength	1000 V <sub>RMS</sub> , 60 Hz	
Taps (Extra)	9 available as special, standard tolerance ± 2°	
Phasing (CCW End Points)	Additional sections phased to section 1 within ± 2°	

MATERIAL SPECIFICATIONS	
Housing and Lids	Aluminum, anodized
Shaft	Stainless steel, non-magnetic non-passivated
Terminals	Brass plated

ENVIRONMENTAL SPECIFICATIONS	
Vibration	15 g thru 2000 CPS
Shock	50 g
Salt Spray	96 h
Rotational Life	1 million shaft revolutions
Load Life	900 h
Operating Temperature Range Moisture Resistant	- 65 °C to + 125 °C 120 h

MARKING	
Unit Identification	Units shall be marked with Vishay Spectrol name, model no and data code, and on each section, resistance, resistance tolerance, linearity and terminal identification

ORDERING INFORMATION/DESCRIPTION			
182S MODEL	1 NUMBER OF SECTIONS From 1 up to 6 (Max.)	20K OHMIC VALUE	B050 PACKAGING Box of 50 pieces
Other characteristics will be standard as described on this data sheet. If special characteristics are required, such as: special linearity tolerance, special resistance tolerance, extra taps, non-linear functions, etc., please state these on your order and allow additional lead time for delivery.			

SAP PART NUMBERING GUIDELINES				
182S MODEL	2 NUMBER OF SECTIONS	103 OHMIC VALUE Section N° 1	103 OHMIC VALUE Section N° 2	B25 PACKAGING Box of 50 pieces



3/4" (19 mm) Single Turn Wirewound  
Servo Mount Precision Potentiometer

Vishay Spectrol

**DIMENSIONS** in inches (millimeters)

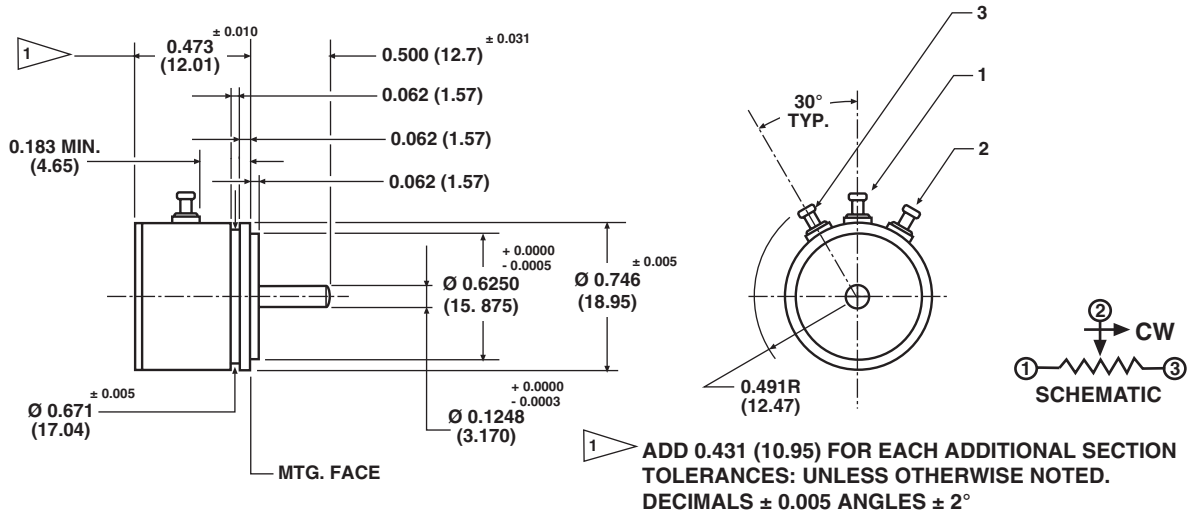

MECHANICAL SPECIFICATIONS		
PARAMETER		
Mechanical Rotation	360° (continuous)	
Bearing Type	Servo mount: Ball bearing	
Ganging	6 sections maximum, terminal alignment, added sections, within ± 10° of section 1 terminals	
Torque (Maximums)	<b>STARTING</b>	<b>RUNNING</b>
1 Section	0.07 oz. - in (5 g - cm)	0.07 oz. - in (5 g - cm)
Each Additional Section	0.07 oz. - in (5 g - cm)	0.07 oz. - in (5 g - cm)
Mechanical Runouts (Maximums):		
Shaft Runout (TIR/in)	0.002" (0.05 cm)	
Pilot Dia. Runout (TIR)	0.002" (0.05 cm)	
Lateral Runout (TIR)	0.002" (0.05 cm)	
Shaft End Play	0.005" (0.13 cm)	
Shaft Radial Play	0.002" (0.05 cm)	
Moment of Inertia	0.12 g - cm <sup>2</sup> per section maximum	
Weight:		
Single Section	0.5 oz. max. (14.50 g)	
Each Additional Section	0.15 oz. max. (4.30 g)	

**POWER RATING CHART**

(Ratings for cup No. 1.  
Additional cups 75 % of values shown)

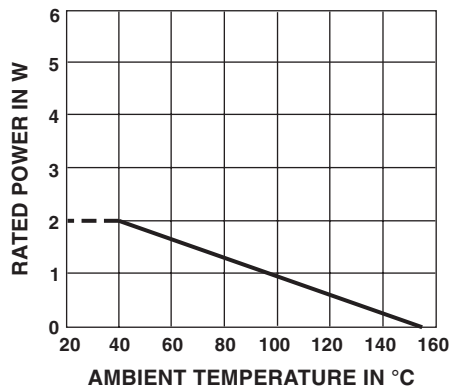

**RESISTANCE ELEMENT DATA**

STANDARD RESISTANCE VALUES (Ω)	RESOLUTION (%)	OHMS PER TURN	MAXIMUM CURRENT AT 70 °C AMBIENT (mA)	MAXIMUM VOLTAGE ACROSS COIL (V)	WIRE TEMP. COEF. (ppm/°C)
5	0.480	0.024	548	2.7	800
10	0.410	0.041	387	3.9	800
20	0.455	0.091	274	5.5	180
50	0.324	0.162	173	8.6	180
100	0.325	0.325	122	12.2	20
200	0.233	0.467	87	17.3	20
500	0.229	1.145	55	27.4	20
1K	0.208	2.087	39	38.7	20
2K	0.138	2.759	27	54.7	20
5K	0.104	5.207	17	86.6	20
10K	0.092	9.236	12	122.5	20
20K	0.080	16.053	9	173.2	20



## 1 3/4" (44.5 mm) Single Turn Wirewound Precision Potentiometer

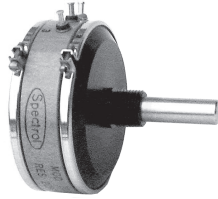

### FEATURES

- Large range of ohmic values: 5 Ω to 65 kΩ
- Screw, servo or bushing mount types available
- Up to 6 sections on the same shaft
- Extra taps upon request



**RoHS**  
COMPLIANT

ELECTRICAL SPECIFICATIONS		
PARAMETER		
Total Resistance Tolerance: 50 Ω and above Below 50 Ω	<b>STANDARD</b> 5 Ω to 50 kΩ ± 3 % ± 5 %	<b>SPECIAL</b> 65 kΩ ± 1 % ± 3 %
Absolute Minimum Resistance	Linearity x total resistance or 0.5 Ω, whichever is greater	
End Voltage	Linearity x total applied voltage for total resistance above 20 Ω, 2.0 % of total applied voltage for 20 Ω and below	
Linearity (Independent) 5 Ω to 50 Ω 50 Ω to 500 Ω 500 Ω to 2 kΩ 2 kΩ and above	<b>STANDARD</b> ± 1.00 % ± 0.50 % ± 0.25 % ± 0.25 %	<b>BEST PRACTICAL</b> ± 0.50 % ± 0.35 % ± 0.20 % ± 0.15 %
Noise	100 Ω ENR	
Electrical Angle	350° ± 2°	
Power Rating: Section 1 : 3.5 W Additional Sections	70 °C ambient derated to zero at 125 °C 75 % of the rating of section 1 (2.6 W at 70 °C)	
Insulation Resistance	1000 MΩ minimum, 500 V <sub>DC</sub>	
Dielectric Strength	1000 V <sub>RMS</sub> , 60 Hz	
Taps (Extra)	From 1 up to 19 (max.)	
Phasing (CCW End Points)	Additional sections phased to section 1 within ± 1°	

ORDERING INFORMATION/DESCRIPTION				
<b>202</b>	<b>C</b>	<b>1</b>	<b>50K</b>	<b>BO1</b>
MODEL	MOUNTING TYPE	NUMBER OF SECTIONS	OHMIC VALUE	PACKAGING
	<b>B:</b> Bushing <b>S:</b> Servo <b>C:</b> Screw	From 1 up to 6 (Max.)		Box of 1 piece
Other characteristics will be standard as described on this data sheet. If special characteristics are required, such as: special linearity tolerance, special resistance tolerance, extra taps, non-linear functions, etc., please state these on your order and allow additional lead time for delivery.				

SAP PART NUMBERING GUIDELINES				
<b>202</b>	<b>S</b>	<b>1</b>	<b>503</b>	<b>BO1</b>
MODEL	MOUNTING TYPE	NUMBER OF SECTIONS	OHMIC VALUE	PACKAGING
	Servo		503 = 50K	Box of 1 piece



1 3/4" (44.5 mm) Single Turn Wirewound Precision Potentiometer

Vishay Spectrol

**DIMENSIONS** in inches (millimeters)

**SCREW MOUNT: 202C**

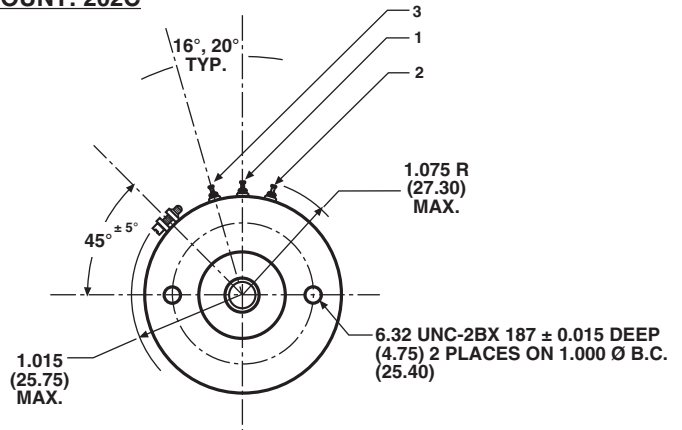
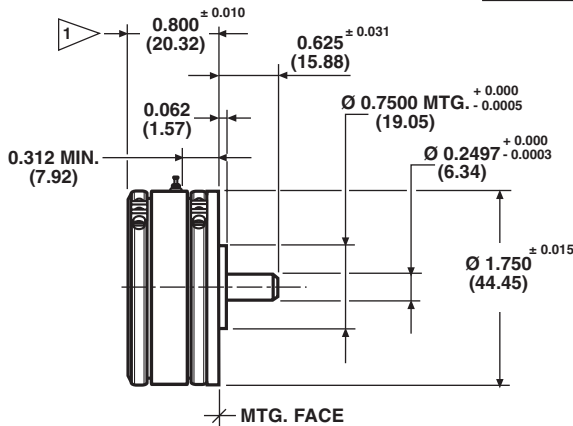

**SERVO MOUNT: 202S**

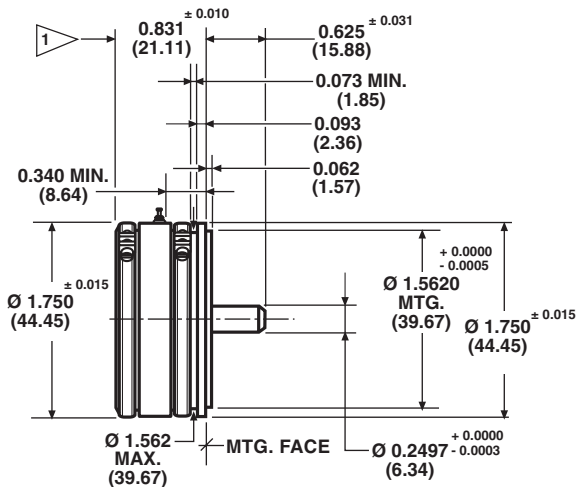

**BUSHING MOUNT: 202B**

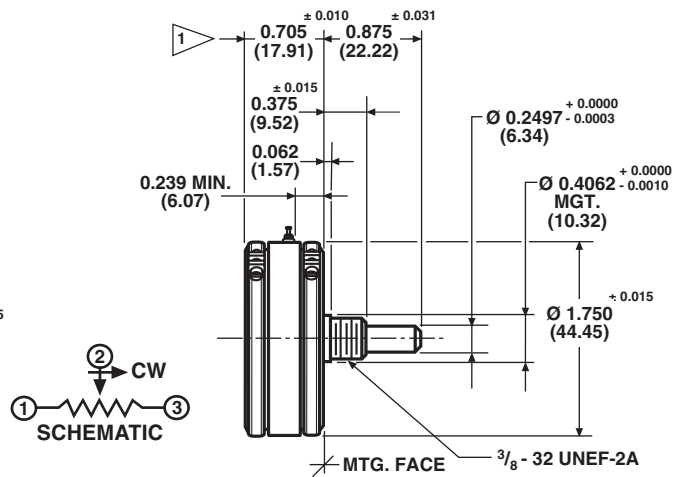

TOLERANCES: UNLESS OTHERWISE NOTED.  
DECIMALS ± 0.005 ANGLES ± 2°

1 ADD 0.500 ± 0.002 FOR EACH ADDITIONAL SECTION (12.70)

MECHANICAL SPECIFICATIONS		
PARAMETER		
Mechanical Rotation	360° (continuous)	
Bearing Type	Screw and servo mount: Ball bearing Bushing mount: Sleeve bearing	
Ganging	6 sections maximum, Terminal alignment, added sections, within ± 10° of section 1 Terminals	
Torque (Maximums) 1 Section Servo and Screw Types Bushing, 1 Section Each Additional Section	<b>STARTING</b> 0.7 oz. - in (50.40 g - cm) 1.0 oz. - in (72.00 g - cm) 0.4 oz. - in (28.80 g - cm)	<b>RUNNING</b> 0.4 oz. - in (28.80 g - cm) 0.7 oz. - in (50.40 g - cm) 0.3 oz. - in (21.60 g - cm)
Mechanical Runouts (Maximums): Shaft Runout (TIR/in) Pilot Dia. Runout (TIR) Lateral Runout (TIR) Shaft End Play Shaft Radial Play	<b>SERVO AND SCREW</b> 0.002" (0.05 cm) 0.002" (0.05 cm) 0.003" (0.08 cm) 0.005" (0.13 cm) 0.002" (0.05 cm)	<b>BUSHING</b> 0.002" (0.05 cm) 0.002" (0.05 cm) 0.005" (0.13 cm) 0.005" (0.13 cm) 0.003" (0.08 cm)
Moment of Inertia	1.0 g - cm <sup>2</sup> per section maximum	
Weight (Maximums): Single Section Each Additional Section	3.0 oz. (85.05 g) 1.0 oz. (28.35 g)	

# Model 202



Vishay Spectrol

1 3/4" (44.5 mm) Single Turn Wirewound  
Precision Potentiometer

MATERIAL SPECIFICATIONS	
Housing and Lids	Aluminum, anodized
Shaft And Clamp Rings	Stainless steel, non-magnetic non-passivated
Terminals	Brass, plated for solderability
Bushing Mount Hardware Lockwasher Internal Tooth: Panel Nut:	Steel, nickel plated Brass, nickel plated

MARKING	
Unit Identification	Units shall be marked with Vishay Spectrol name, model number and data code on each section, resistance, resistance tolerance, linearity and terminal identification

ENVIRONMENTAL SPECIFICATIONS	
Vibration	15 g thru 2000 Hz
Shock	50 g
Salt Spray	96 h
Rotational Life	1 million shaft revolutions
Load Life	900 h
Operating Temperature Range	- 55 °C to + 125 °C

## POWER RATING CHART

(Ratings for cup No.1.

Additional cups 75 % of values shown)

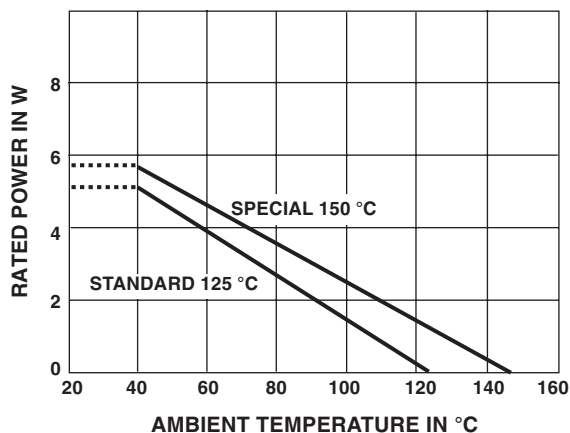

RESISTANCE ELEMENT DATA					
STANDARD RESISTANCE VALUES (Ω)	RESOLUTION (%)	OHMS PER TURN	MAXIMUM CURRENT AT 70 °C AMBIENT (mA)	MAXIMUM VOLTAGE ACROSS COIL (V)	TEMP. COEF. (ppm/°C)
5	0.320	0.016	835	4.19	800
10	0.240	0.024	591	5.92	800
20	0.190	0.038	418	8.37	800
50	0.212	0.106	264	13.3	20
100	0.181	0.181	187	18.7	20
200	0.150	0.300	133	26.3	20
500	0.115	0.575	83.4	42.0	20
1K	0.103	1.03	59.1	59.2	20
2K	0.094	1.89	41.8	83.7	20
5K	0.068	3.42	26.4	133	20
10K	0.059	5.91	18.7	187	20
20K	0.048	9.52	13.2	265	20
50K	0.044	22.0	8.37	422	20

## 2" (50.8 mm) Single Turn Wirewound Precision Potentiometer



### FEATURES

- Screw, servo and bushing mount types available
- Large range of ohmic values: 5  $\Omega$  to 85 k $\Omega$
- Extra taps upon request
- Gangable up to 6 sections on a same shaft



**RoHS**  
COMPLIANT

ELECTRICAL SPECIFICATIONS		
PARAMETER	STANDARD	SPECIAL
Total Resistance: Tolerance 50 $\Omega$ and Above Below 50 $\Omega$	5 $\Omega$ to 50 k $\Omega$ $\pm 3\%$ $\pm 5\%$	85 k $\Omega$ $\pm 1\%$ $\pm 3\%$
Absolute Minimum Resistance	Linearity x total resistance or 0.5 $\Omega$ whichever is greater	
End Voltage	Linearity x total applied voltage for total resistance above 20 $\Omega$ , 2.0 % of total applied voltage for 20 $\Omega$ and below	
Linearity (Independent) 5 $\Omega$ to 50 $\Omega$ 50 $\Omega$ to 200 $\Omega$ 200 $\Omega$ to 1 k $\Omega$ 1 k $\Omega$ to 10 k $\Omega$ 10 k $\Omega$ and Above	<b>STANDARD</b> $\pm 1.0\%$ $\pm 0.50\%$ $\pm 0.25\%$ $\pm 0.25\%$ $\pm 0.25\%$	<b>BEST PRACTICAL</b> $\pm 0.50\%$ $\pm 0.35\%$ $\pm 0.20\%$ $\pm 0.15\%$ $\pm 0.10\%$
Noise	100 $\Omega$ ENR	
Electrical Angle	350° $\pm 2^\circ$	
Power Rating Section 1: 4.0 W Additional Sections	70 °C ambient derated to zero at 125 °C 75 % of the rating of section 1 (3.0 W at 70 °C)	
Insulation Resistance	1000 M $\Omega$ minimum 500 V <sub>DC</sub>	
Dielectric Strength	1000 V <sub>RMS</sub> , 60 Hz	
Taps (Extra)	21 available as special, standard tolerance $\pm 1^\circ$	
Phasing (CCW End Points)	Additional sections phased to section 1 within $\pm 1^\circ$	

ORDERING INFORMATION/DESCRIPTION				
302	C	1	500	BO1
MODEL	MOUNTING TYPE	NUMBER OF SECTIONS	OHMIC VALUE	PACKAGING
	<b>B:</b> Bushing <b>S:</b> Servo <b>C:</b> Screw	From 1 up to 6 (Max.)	500 $\Omega$	Box of 1 piece
Other characteristics will be standard as described on this data sheet. If special characteristics are required, such as: special linearity tolerance, special resistance tolerance, extra taps, non-linear functions, etc., please state these on your order and allow additional lead time for delivery.				

SAP PART NUMBERING GUIDELINES					
302	S	2	103	202	BO1
MODEL	MOUNTING TYPE	NUMBER OF SECTIONS	OHMIC VALUE	OHMIC VALUE	PACKAGING
	<b>S:</b> Servo		Section N <sup>o</sup> 1 103 = 10K	Section N <sup>o</sup> 2 202 = 2K	Box of 1 piece

# Model 302

Vishay Spectrol

2" (50.8 mm) Single Turn Wirewound  
Precision Potentiometer



## DIMENSIONS in inches (millimeters)

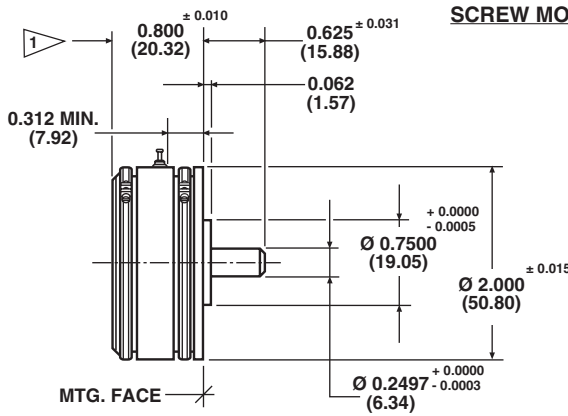

**SCREW MOUNT: 302C**

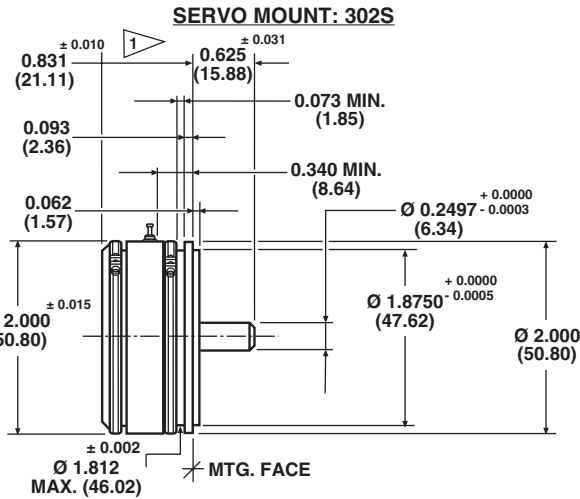
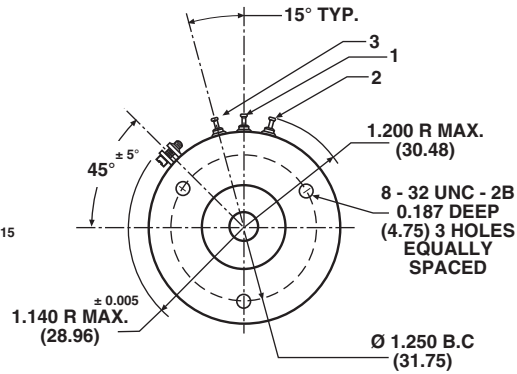

**SERVO MOUNT: 302S**

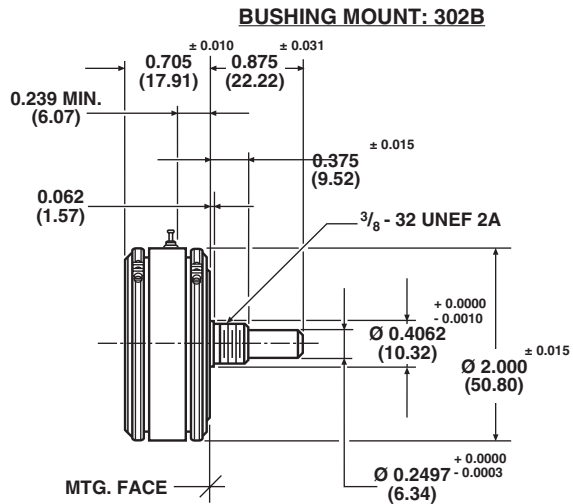

**BUSHING MOUNT: 302B**

1 ADD 0.500 (12.70) FOR EACH ADDITIONAL SECTION

TOLERANCES: UNLESS OTHERWISE NOTED.  
DECIMALS ± 0.005 ANGLES ± 2°

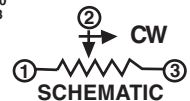

MECHANICAL SPECIFICATIONS		
PARAMETER		
Rotation	360° (continuous)	
Bearing Type	Servo and screw mount: Ball Bushing mount: Sleeve	
Ganging	6 sections maximum, terminal alignment, added sections, within ± 10° of section 1 terminals	
Torque (Maximums)	<b>STARTING</b>	<b>RUNNING</b>
Servo and Screw (1 Section)	1.0 oz. - in (72.00 g - cm)	0.5 oz. - in (36.00 g - cm)
Bushing (1 Section)	1.7 oz. - in (122.42 g - cm)	1.0 oz. - in (72.00 g - cm)
Each added Section	0.6 oz. - in (43.21 g - cm)	0.4 oz. - in (28.80 g - cm)
Mechanical Runouts (Maximums)	<b>SERVO AND SCREWING</b>	<b>BUSHING</b>
Shaft TIR/in	0.002" (0.05 cm)	0.002" (0.05 cm)
Pilot dia TIR	0.002" (0.05 cm)	0.002" (0.05 cm)
Lateral TIR	0.003" (0.08 cm)	0.005" (0.13 cm)
Shaft End Play	0.005" (0.13 cm)	0.005" (0.13 cm)
Shaft Radial Play	0.002" (0.05 cm)	0.003" (0.08 cm)
Moment of Inertia	2.0 g - cm <sup>2</sup> per section maximum	
Weight (Maximums)		
Single Section:	4.0 oz. (113.40 g)	
Each Additional Section:	1.2 oz. (34.02 g)	



**2" (50.8 mm) Single Turn Wirewound Precision Potentiometer**

Vishay Spectrol

MATERIAL SPECIFICATIONS	
Housing and Lids	Aluminum, anodized
Shaft and Clamp Rings	Stainless steel, non-magnetic non-passivated
Terminals	Brass, plated for solderability
Bushing Mount Hardware Lockwasher Internal Tooth: Panel Nut:	Steel, nickel plated Brass, nickel plated

ENVIRONMENTAL SPECIFICATIONS	
Vibration	15 g thru 2000 Hz
Shock	50 g
Salt Spray	96 h
Rotational Life	1 million shaft revolutions
Temperature Range	- 55 °C to + 125 °C

MARKING	
<b>Unit Identification</b>	Units shall be marked with Vishay Spectrol name, model no and date code, and on each section, resistance, resistance tolerance, linearity and terminal identification

**POWER RATING CHART**

(Ratings for cup No. 1.  
Additional cups 75 % of values shown)

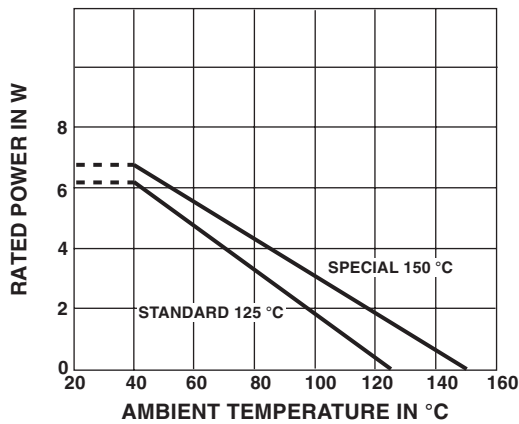

RESISTANCE ELEMENT DATA					
RESISTANCE VALUES (Ω)	RESOLUTION (%)	OHMS PER TURN	MAXIMUM CURRENT AT 40 °C AMBIENT (mA)	MAXIMUM VOLTAGE ACROSS COIL (V)	WIRE TEMP. COEF. (ppm/°C)
5	0.320	0.016	893	4.48	800
10	0.200	0.020	633	6.32	800
20	0.165	0.033	447	8.95	800
50	0.148	0.074	283	14.1	800
100	0.151	0.151	200	20.0	20
200	0.126	0.252	141	28.4	20
500	0.115	0.573	89.4	44.7	20
1K	0.098	0.981	63.3	63.2	20
2K	0.085	1.70	44.7	89.5	20
5K	0.059	2.93	28.3	141	20
10K	0.051	5.16	20.0	200	20
20K	0.043	8.55	14.1	284	20
50K	0.032	15.80	8.94	447	20

## 3" (76.2 mm) Single Turn Wirewound Precision Potentiometer



This Model 402 is only for maintenance purposes. It is not recommended for new designs and will be obsolete in a near future.

### FEATURES

- Large range of ohmic values: 10 Ω up to 150 kΩ
- Bushing mount, servo mount and screwing mount available
- Extra taps upon request
- Gangable up to 6 sections



ELECTRICAL SPECIFICATIONS		
PARAMETER		
Total Resistance: Tolerance: 100 Ω and Above Below 100 Ω:	<b>STANDARD</b> 10 Ω to 100 kΩ ± 3 % ± 5 %	<b>SPECIAL</b> 150 kΩ ± 1 % ± 3 %
Absolute Minimum Resistance	Linearity x total resistance or 0.5 Ω whichever is greater	
End Voltage	Linearity x total applied voltage for total resistance above 20 Ω, 2.0 % of total voltage for 20 Ω and below	
Linearity (Independent) Total Resistance 10 Ω to 200 Ω 200 Ω to 2 kΩ 2 kΩ to 10 kΩ 10 kΩ and Above	<b>STANDARD</b> ± 0.50 % ± 0.25 % ± 0.25 % ± 0.25 %	<b>BEST PRACTICAL</b> ± 0.25 % ± 0.15 % ± 0.10 % ± 0.075 %
Noise	100 Ω ENR	
Electrical Angle	350° ± 2°	
Power Rating Section 1 Additional Section	6.0 W at 70 °C ambient derated to zero at 125 °C 75 % of the rating of section 1 (4.5 W at 70 °C)	
Insulation Resistance	1000 MΩ minimum 500 V <sub>DC</sub>	
Dielectric Strength	1000 V <sub>RMS</sub> , 60 Hz	
Taps (Extra)	37 available as special, standard tolerance ± 1°	
Phasing (CCW End Points)	Additional sections phased to section 1 within ± 1°	

### ORDERING INFORMATION/DESCRIPTION

The Model 402 can be ordered from this specification sheet with a variety of alternate characteristics, are as shown above. For most rapid service on your order, please state:

402	B	1	100K	B01
MODEL	MOUNTING TYPE	NUMBER OF SECTIONS	OHMIC VALUE	PACKAGING
	B: Bushing S: Servo C: Screw	From 1 up to 6 (Max.)		Box of 1 piece

Other characteristics will be standard as described on this data sheet. If special characteristics are required, such as: special linearity tolerance, special resistance tolerance, extra taps, non-linear functions, etc., please state these on your order and allow additional lead time for delivery.

### SAP PART NUMBERING GUIDELINES

402	C	2	101	104	B01
MODEL	MOUNTING TYPE	NUMBER OF SECTIONS	OHMIC VALUE	OHMIC VALUE	PACKAGING
	C: Screw		Section N° 1 101 = 100 Ω	Section N° 2 104 = 100 kΩ	Box of 1 piece



3" (76.2 mm) Single Turn Wirewound Precision Potentiometer

Vishay Spectrol

**DIMENSIONS** in inches (millimeters)

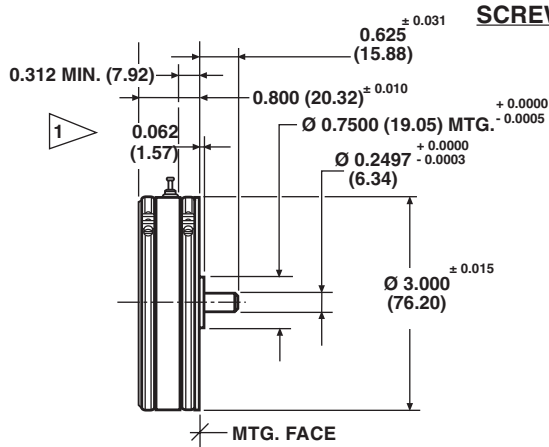

**SCREW MOUNT: 402C**

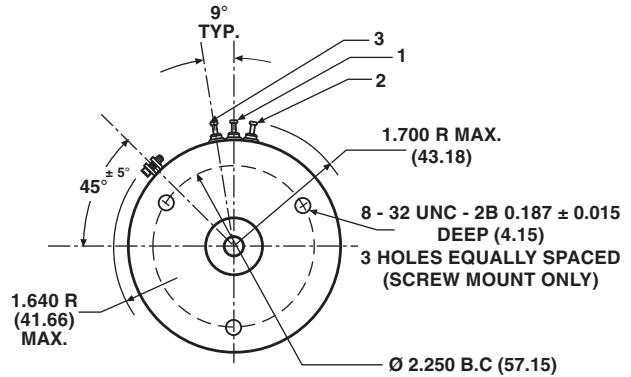

**SERVO MOUNT: 402S**

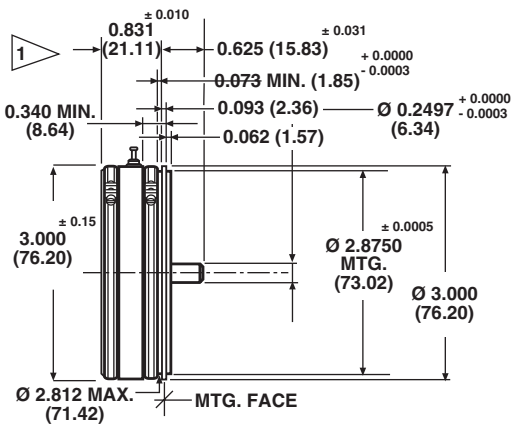

**BUSHING MOUNT: 402B**

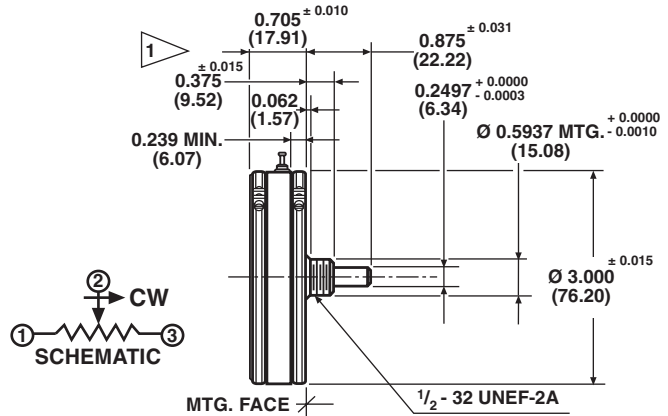

1 ADD 0.500 (12.70) FOR EACH ADDITIONAL SECTION.

MECHANICAL SPECIFICATIONS		
PARAMETER		
Rotation	360° (continuous)	
Bearing Type Servo and Screw Mount: Bushing Mount	Ball bearing Sleeve bearing	
Ganging	6 sections maximum terminal alignment, added sections, within ± 10° of section 1 terminals	
Torque (Maximum) Mounting: Servo or Screw 1 Section Bushing 1 Section Each additional Section	<b>STARTING</b>  1.1 oz. - in (79.21 g - cm) 1.9 oz. - in (136.82 g - cm) 0.8 oz. - in (57.61 g - cm)	<b>RUNNING</b>  0.6 oz. - in (43.20 g - cm) 1.1 oz. - in (79.21 g - cm) 0.5 oz. - in (36.00 g - cm)
Runouts (Maximums) Shaft (TIR/in) Pilot dia (TIR) Lateral (TIR) Shaft End Play Shaft Radial Play	<b>SERVO</b> 0.002" (0.05 cm) 0.002" (0.05 cm) 0.004" (0.10 cm) 0.005" (0.13 cm) 0.002" (0.05 cm)	<b>BUSHING</b> 0.002" (0.05 cm) 0.002" (0.05 cm) 0.005" (0.13 cm) 0.005" (0.13 cm) 0.003" (0.08 cm)
Moment of Inertia	4.0 g - cm <sup>2</sup> per section maximum	
Weight (Maximums) Each Additional Section:	Single section: 7.0 oz. (198.45 g) 2.0 oz. (56.70 g)	



# Model 402



Vishay Spectrol

3" (76.2 mm) Single Turn Wirewound  
Precision Potentiometer

MATERIAL SPECIFICATIONS	
Housing and Lids	Aluminum, anodized
Shaft and Clamp Rings	Stainless steel, non-magnetic non-passivated
Terminals	Brass, plated for solderability
Bushing Mount Hardware Lockwasher Internal Tooth: Panel Nut:	Steel, nickel plated Brass, nickel plated

ENVIRONMENTAL SPECIFICATIONS	
Vibration	15 g thru 2000 CPS
Shock	50 g
Salt Spray	96 h
Rotational Life	1 million shaft revolutions
Load Life	900 h
Temperature Range	- 55 °C + 125 °C

MARKING	
Unit Identification	Units shall be marked with Vishay Spectrol name, model no, data code and on each section, resistance, resistance tolerance, linearity and terminal identification

## POWER RATING CHART

(Ratings for cup No. 1.  
Additional cups 75 % of values shown)

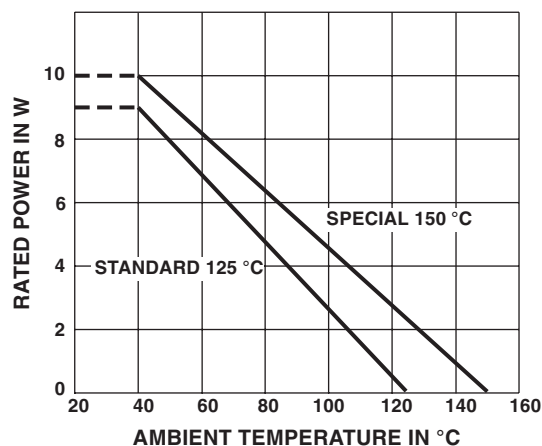

RESISTANCE ELEMENT DATA					
RESISTANCE VALUES (Ω)	RESOLUTION (%)	OHMS PER TURN	MAXIMUM CURRENT AT 70 °C AMBIENT (mA)	MAXIMUM VOLTAGE ACROSS COIL (V)	WIRE TEMP. COEF. (ppm/°C)
10	0.160	0.016	775	7.74	800
20	0.120	0.024	548	10.9	800
50	0.094	0.047	347	17.3	800
100	0.106	0.106	245	24.5	20
200	0.091	0.181	173	34.7	20
500	0.072	0.361	110	54.5	20
1K	0.057	0.575	77.5	77.4	20
2K	0.056	1.12	54.8	109	20
5K	0.042	2.09	34.6	173	20
10K	0.034	3.42	24.5	245	20
20K	0.025	5.07	17.3	347	20
50K	0.019	9.41	11.0	545	20
100K	0.018	18.0	7.74	775	20
150K	0.023	34.4	6.32	949	20

## 3" (76.2 mm) Single Turn Wirewound Servo Mount, Precision Potentiometer, Sine/Cosine Laws

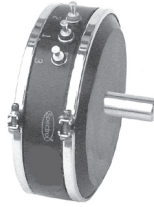

### FEATURES

- No dead band, signal over full 360°
- Gangable up to 6 sections
- Large range of ohmic values: 250 Ω to 25 kΩ
- 2 output signals: 1) Sine; 2) Cosine
- Conformity from ± 0.5 % down to ± 0.2 %



**RoHS**  
COMPLIANT

This Model 452 is only for maintenance purposes. It is not recommended for new designs and will be obsolete in a near future.

ELECTRICAL SPECIFICATIONS		
PARAMETER		
Total Resistance: Tolerance:	<b>STANDARD</b> 250 Ω to 25 kΩ per quad ± 3 %	<b>SPECIAL</b> - ± 1 %
Output Function	E1/E = SIN θ and E2/E = COS θ	
Conformity (% of 2 E)	STD 0.5 %, best practical 0.3 % 250 Ω < R <sub>T</sub> < 2500 Ω STD 0.3 %, best practical 0.2 % 2500 Ω < R <sub>T</sub> < 25 000 Ω	
Index Point	This index point is the actual voltage ratio at θ = 10° of the sine wiper of the first section	
Noise	100 Ω ENR	
Electrical Angle	360° continuous	
Power Rating Section 1 Additional Section	125 °C unit, 6.0 W at 70 °C derated to zero at 125 °C 75 % of the rating of section 1 (6 W at 70 °C)	
Insulation Resistance	1000 MΩ minimum 500 V <sub>DC</sub>	
Dielectric Strength	1000 V <sub>RMS</sub> , 60 Hz	
Phasing	Multiple sections are phased for simultaneous conformity	

ORDERING INFORMATION/DESCRIPTION			
The Model 452 can be ordered from this data sheet with a variety of alternate characteristics, as shown above. For most rapid service on your order, please state:			
<b>452S</b>	<b>1</b>	<b>5K</b>	<b>BO1</b>
MODEL	NUMBER OF SECTIONS	OHMIC VALUE	PACKAGING
	From 1 up to 6 (max.)		Box of 1 piece

SAP PART NUMBERING GUIDELINES				
<b>452S</b>	<b>2</b>	<b>251</b>	<b>502</b>	<b>B01</b>
MODEL	NUMBER OF SECTIONS	OHMIC VALUE	OHMIC VALUE	PACKAGING
		Section N° 1 251 = 250 Ω	Section N° 2 502 = 5 kΩ	Box of 1 piece

# Model 452



Vishay Spectrol 3" (76.2 mm) Single Turn Wirewound Servo Mount, Precision Potentiometer, Sine/Cosine Laws

## DIMENSIONS in inches (millimeters)

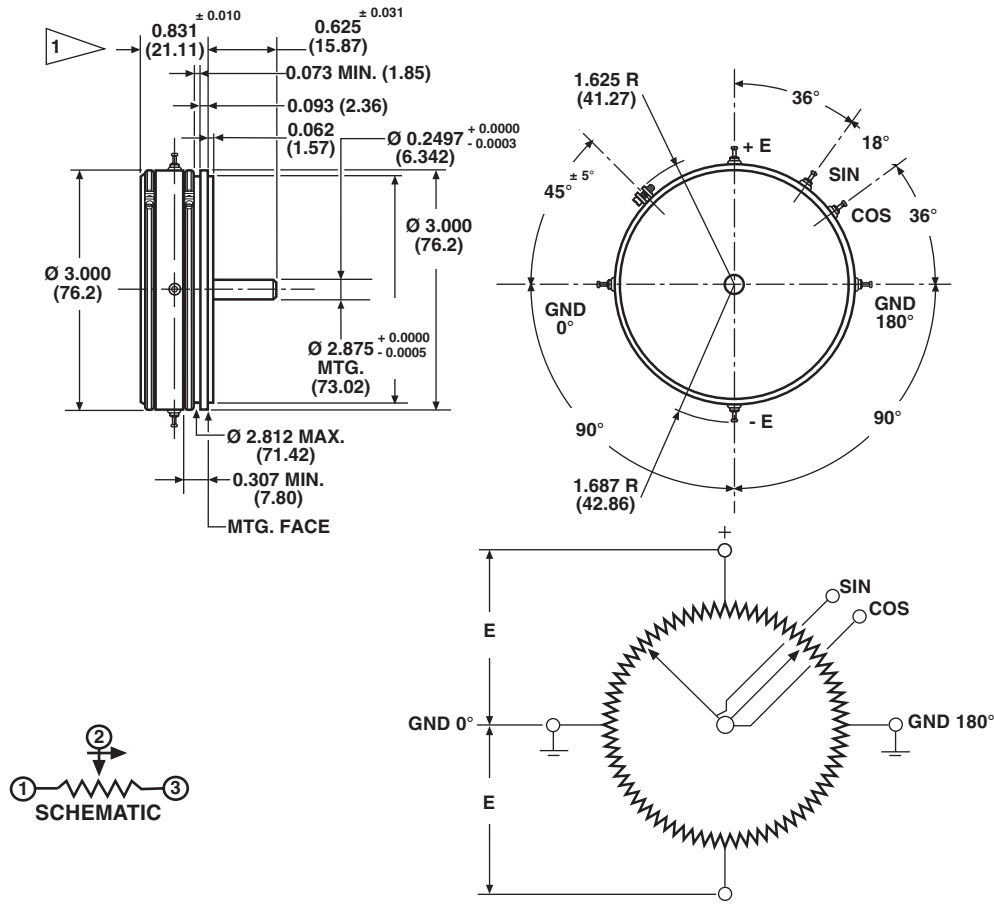

TOLERANCES: UNLESS OTHERWISE NOTED.  
DECIMALS ± 0.005 ANGLES ± 2°

1 ADD 0.500 ± 0.002 (12.70) FOR EACH ADDITIONAL SECTION

MECHANICAL SPECIFICATIONS		
PARAMETER		
Rotation	360° (continuous)	
Bearing Type	Ball bearing front-bushing rear	
Ganging	6 sections maximum Terminal alignment, added sections, within ± 10° of section 1 terminals	
Torque (Maximum)		
Servo Section 1	<b>STARTING</b> 1.9 oz. - in (136.8 g - cm)	<b>RUNNING</b> 1.1 oz. - in (79.2 g - cm)
Each Additional Section	1.6 oz. - in (115.2 g - cm)	1.0 oz. - in (72.0 g - cm)
Mechanical Runouts (Maximums):	<b>SERVO</b>	
Shaft (TIR/in)	0.002" (0.05 cm)	
Pilot Dia. (TIR)	0.002" (0.05 cm)	
Lateral (TIR)	0.004" (0.10 cm)	
Shaft End Play	0.0015" (0.04 cm)	
Shaft Radial Play	0.002" (0.05 cm)	
Moment of Inertia	10.0 g - cm <sup>2</sup> per section maximum	
Weight:		
Single Section	7.0 oz. (198.8 g)	
Each Additional Section:	2.0 oz. (56.8 g)	



3" (76.2 mm) Single Turn Wirewound Servo Mount, Vishay Spectrol Precision Potentiometer, Sine/Cosine Laws

MATERIAL SPECIFICATIONS	
Housing and Lids	Aluminum, anodized
Shaft and Clamp Rings	Stainless steel, non-magnetic non-passivated
Terminals	Brass, plated for solderability
Bearings	Stainless steel ball bearing (front) Bronze bushing (rear)

MARKING	
Unit Identification	Units shall be marked with Vishay Spectrol model no. and on each section, resistance, conformity and terminal identification. Index point shall be marked on periphery of the first section

ENVIRONMENTAL SPECIFICATIONS	
Vibration	10 g thru 2000 CPS
Shock	50 g
Salt Spray	96 h
Rotational Load Life	250 000 shaft revolutions
Operating Temperature Range	(125 °C unit) - 65 °C to + 125 °C
Moisture Resistant	10 cycles
DEGRADATION AFTER ROTATIONAL LOAD LIFE TEST	
Conformity	Not more than 150 % of the initial value
Noise	500 Ω
Insulation Resistance	Not less than 100 MΩ
Torque	Not more than 150 % of the initial value

**POWER RATING CHART**

(Ratings for cup No. 1.  
Additional cups 75 % of values shown)

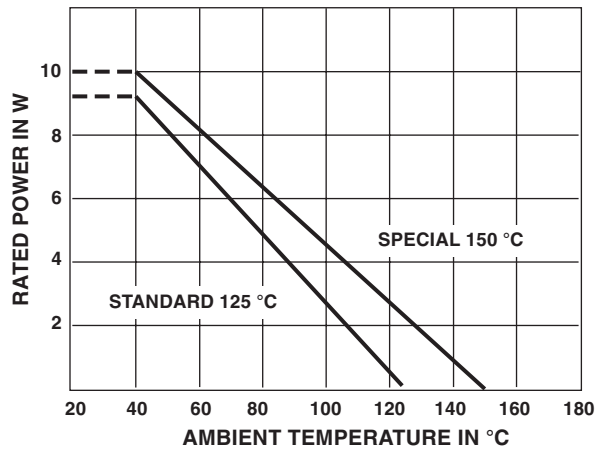

RESISTANCE ELEMENT DATA					
TOTAL RESISTANCE VALUES (Ω)	RESOLUTION (%) (PK-PK)	MAXIMUM CURRENT AT 70 °C AMBIENT (mA)	MAXIMUM VOLTAGE ACROSS COIL (V)	WIRE TEMP. COEF. (ppm/°C)	WIRE RESISTIVITY (Ω/CMF)
250	0.196	154.9	38.7	± 20	800
500	0.156	110.0	54.5	± 20	800
1000	0.121	77.5	77.4	± 20	800
2500	0.093	48.9	122.5	± 20	800
5000	0.080	34.6	173.0	± 20	800
10 000	0.071	24.5	245.0	± 20	800
15 000	0.066	20.0	300.0	± 20	800
20 000	0.063	17.3	347.0	± 20	800
25 000	0.062	15.5	387.0	± 20	800

## 7/8" (22.2 mm) Single Turn Wirewound Precision Potentiometer

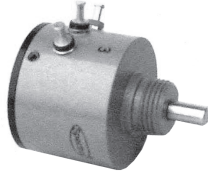

### FEATURES

- Large range of ohmic values: from 5 Ω up to 100 kΩ
- Bushing mount or servo mount types are available
- Extra taps upon request
- Gangable up to 6 sections



ELECTRICAL SPECIFICATIONS		
PARAMETER	STANDARD	SPECIAL
Total Resistance: (Bushing 91 kΩ max.) Tolerance: 20 Ω and above Below 20 Ω	5 Ω to 20 kΩ  ± 3 % ± 5 %	5 Ω to 100 kΩ  ± 1 % ± 3 %
Absolute Minimum Resistance	Linearity x total resistance or 0.5 Ω whichever is greater	
End Voltage	Linearity x total applied voltage for total resistance above 20 Ω, 2.0 % of total applied voltage for 20 Ω and below	
Linearity (Independent) 5 Ω to 100 Ω 100 Ω to 500 Ω 500 Ω to 5 kΩ 5 kΩ and Above	STANDARD ± 1.0 % ± 1.0 % ± 0.5 % ± 0.5 %	BEST PRACTICAL ± 0.75 % ± 0.50 % ± 0.35 % ± 0.25 %
Noise	100 Ω ENR	
Electrical Angle	350° ± 2°	
Power Rating Section 1 Additional Sections	1.25 W at 70 °C ambient derated to zero at 125 °C 75 % of the rating of section 1 (0.94 W at 70 °C)	
Insulation Resistance	1000 MΩ minimum 500 V <sub>DC</sub>	
Dielectric Strength	1000 V <sub>RMS</sub> , 60 Hz	
Taps (Extra)	9 available as special, standard tolerance ± 2°	
Phasing (CCW End Points)	Additional sections phased to section 1 within ± 1°	

ORDERING INFORMATION/DESCRIPTION				
The Model 702 can be ordered from this data sheet with a variety of alternate characteristics, as shown. For most rapid service on your order, please state:				
<b>702</b> MODEL	<b>B</b> MOUNTING TYPE <b>B:</b> Bushing <b>S:</b> Servo	<b>1</b> NUMBER OF SECTIONS From 1 up to 6 sections (max.)	<b>20K</b> OHMIC VALUE	<b>BO1</b> PACKAGING Box of 1 piece
Other characteristics will be standard as described on this data sheet. If special characteristics are required, such as: special linearity tolerance, special resistance tolerance, extra taps, non-linear functions, etc., please state these on your order and allow additional lead time for delivery.				

SAP PART NUMBERING GUIDELINES					
<b>702</b> MODEL	<b>S</b> MOUNTING TYPE <b>S:</b> Servo	<b>2</b> NUMBER OF SECTIONS	<b>050</b> OHMIC VALUE Section N° 1 050 = 5 Ω	<b>100</b> OHMIC VALUE Section N° 2 100 = 10 Ω	<b>B01</b> PACKAGING Box of 1 piece

**7/8" (22.2 mm) Single Turn Wirewound  
Precision Potentiometer**

Vishay Spectrol

**DIMENSIONS** in inches (millimeters)

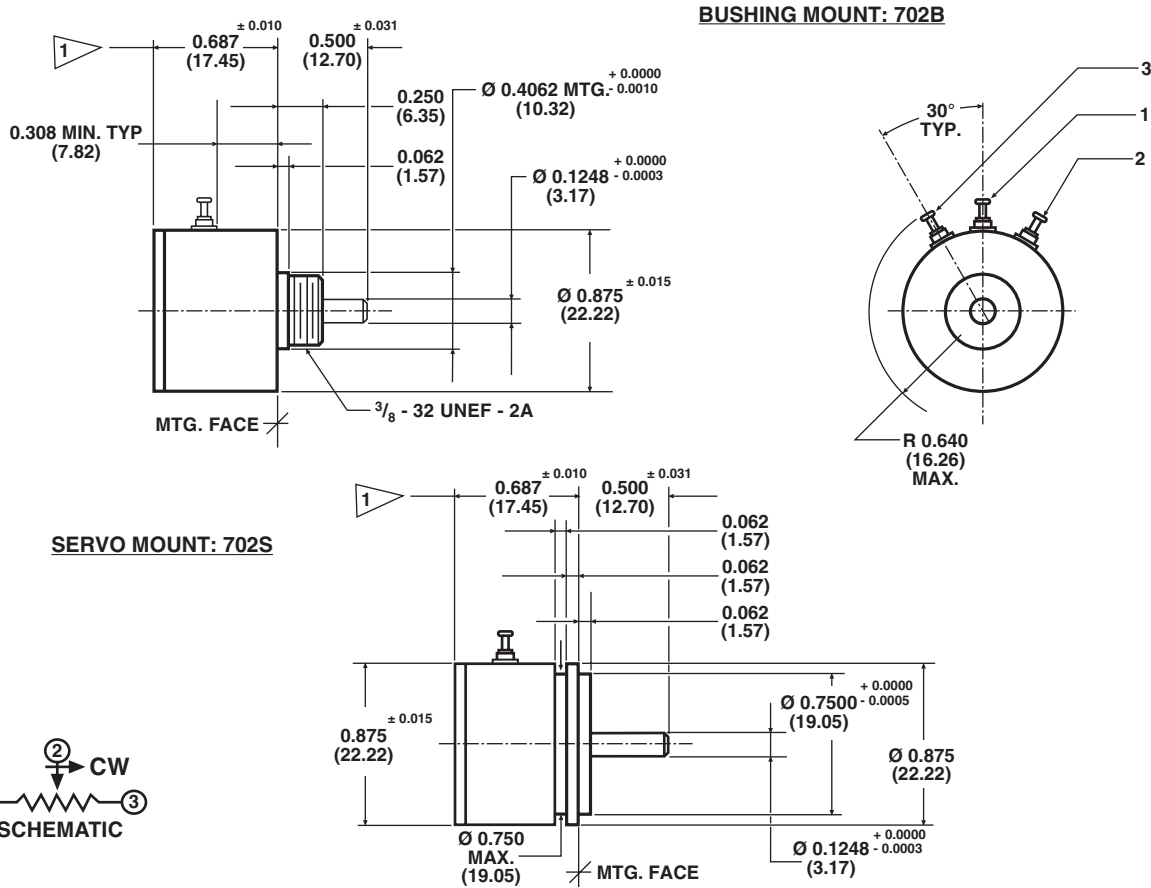

1 ADD 0.500 (12.70) ± 0.002 FOR EACH ADDITIONAL SECTION

TOLERANCES: UNLESS OTHERWISE NOTED.  
DECIMALS ± 0.005 ANGLES ± 2°

<b>MECHANICAL SPECIFICATIONS</b>		
PARAMETER		
Rotation	360° continuous	
Bearing Type	<b>SERVO</b> Ball bearing	<b>BUSHING</b> Sleeve bearing
Ganging	6 sections maximum Terminal alignment, added sections within ± 10° of section 1 terminals	
Torque (Maximum)	<b>STARTING</b>	<b>RUNNING</b>
Servo Section 1	0.10 oz. - in (7.20 g - cm)	0.085 oz. - in (6.12 g - cm)
Bushing Section 1	0.25 oz. - in (18.00 g - cm)	0.20 oz. - in (14.40 g - cm)
Each Additional Section	0.10 oz. - in (7.20 g - cm)	0.075 oz. - in (5.40 g - cm)
Mechanical Runouts (Maximums):	<b>SERVO</b>	<b>BUSHING</b>
Shaft Runout (TIR/In)	0.002" (0.05 cm)	0.002" (0.05 cm)
Pilot Dia. Runout (TIR)	0.002" (0.05 cm)	0.002" (0.05 cm)
Lateral Runout (TIR)	0.002" (0.05 cm)	0.005" (0.13 cm)
Shaft End Play	0.005" (0.13 cm)	0.005" (0.13 cm)
Shaft Radial Play	0.002" (0.05 cm)	0.004" (0.10 cm)
Moment of Inertia	0.12 g - cm <sup>2</sup> per section maximum	
Weight:		
Single Section	0.6 oz. (17.01 g)	
Each Additional Section	0.2 oz. (5.67 g)	

# Model 702



Vishay Spectrol

7/8" (22.2 mm) Single Turn Wirewound  
Precision Potentiometer

MATERIAL SPECIFICATIONS	
Housing and Lids	Aluminum, anodized
Shaft	Stainless steel, non-magnetic non-passivated
Terminals	Brass, plated for solderability
Bushing Mount Hardware Lockwasher Internal Tooth: Panel Nut:	Steel, nickel plated Brass, nickel plated

MARKING	
Unit Identification	Units shall be marked with Vishay Spectrol name, model no and date code, and on each section: resistance, resistance tolerance, linearity and terminal identification

ENVIRONMENTAL SPECIFICATIONS	
Vibration	15 g thru 2000 CPS
Shock	50 g
Salt Spray	96 h
Rotational Life	1 million shaft revolutions
Load Life	900 h
Operating Temperature Range:	- 55 °C + 125 °C

## POWER RATING CHART

(Ratings for cup No. 1.  
Additional cups 75 % of values shown)

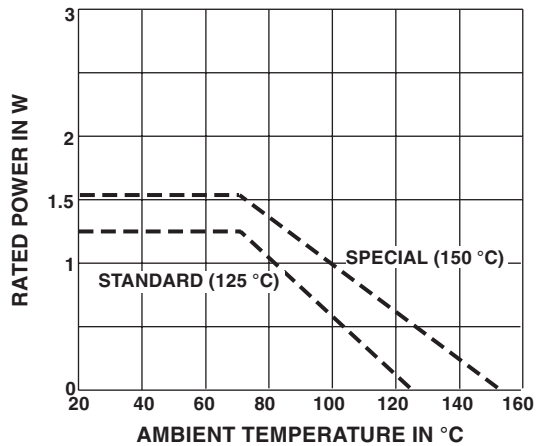

RESISTANCE ELEMENT DATA					
STANDARD RESISTANCE VALUES (Ω)	RESOLUTION (%)	OHMS PER TURN	MAXIMUM CURRENT AT 70 °C AMBIENT (mA)	MAXIMUM VOLTAGE ACROSS COIL (V)	WIRE TEMP. COEF. (ppm/°C)
5	0.460	0.023	500	2.50	800
10	0.378	0.038	354	3.54	800
20	0.374	0.075	250	5.00	180
50	0.300	0.150	158	7.90	180
100	0.271	0.271	112	11.2	20
200	0.235	0.478	79.1	15.8	20
500	0.206	1.03	50.0	25.0	20
1K	0.156	1.56	35.4	35.4	20
2K	0.127	2.55	25.0	50.0	20
5K	0.101	5.07	15.8	79.0	20
10K	0.95	8.50	11.2	112.0	20
20K	0.90	17.9	7.90	158.0	20
50K	0.75	37.9	5.00	250.0	20
100K	0.65	64.5	3.54	354.0	20



# Wirewound Technology Multiturn Models

## Contents

Model 162 .....	116
Model 164 .....	118
Model 502 .....	120
Model 533/534/535 .....	123
Model 536 .....	126
Model 552 .....	129
Model 802 .....	132
Model 830 .....	135
Model 852 .....	138
Model 860 .....	141

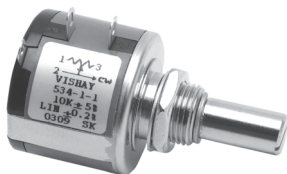



## 1/2" (12.7 mm) Ten Turn Wirewound Bushing Mount Precision Potentiometer



### FEATURES

- Large range of ohmic values: 100 Ω to 100 kΩ
- Smallest size available on the market
- Very easy and accurate adjustment



ELECTRICAL SPECIFICATIONS		
PARAMETER		
Total Resistance Standard Range Tolerance	<b>STANDARD</b> 100 Ω to 100 kΩ ± 5 %	<b>SPECIAL</b> 115 kΩ ± 1 %
Linearity (Independent)	<b>STANDARD</b> ± 0.30 %	<b>BEST PRACTICAL</b> ± 0.15 %
Noise	100 Ω ENR	
Electrical Angle	3600° + 15° - 0°	
Power Rating	2.0 W at 40 °C ambient, derated to zero at 125 °C	
Insulation Resistance	100 MΩ minimum, 500 V <sub>DC</sub>	
Dielectric Strength	500 V <sub>RMS</sub> , 60 Hz	
Absolute Minimum Resistance	Linearity x total resistance or 0.5 Ω, whichever is greater	
End Voltage	Linearity x total applied voltage for total resistance above 20 Ω, 2.0 % of total applied voltage for 20 Ω and below	

MATERIAL SPECIFICATIONS	
Housing and Lids	Molded, glass filled, thermoset plastic
Bushing	Brass, nickel plated
Shaft	Stainless steel, non-passivated
Terminals	Brass, plated for solderability
Bushing Mount Hardware Lockwasher Internal Tooth: Panel Nut:	Steel, nickel plated Brass, nickel plated

MARKING	
<b>Unit Identification</b>	Units shall be marked with Vishay Spectrol name and model no, resistance and resistance tolerance, linearity, terminal identification and date code

ENVIRONMENTAL SPECIFICATIONS	
Vibration	15 g thru 2000 Hz
Shock	50 g
Salt Spray	48 h
Rotational Life	500 000 shaft revolutions
Temperature Range	- 55 °C to + 125 °C

ORDERING INFORMATION/DESCRIPTION				
The Model 162 can be ordered from this data sheet with a variety of alternate characteristics, as shown. For most rapid service on your order, please state:				
<b>162</b>	<b>B</b>	<b>10K</b>	<b>B05</b>	<b>e4</b>
MODEL	STYLE (BUSHING)	TOTAL RESISTANCE	PACKAGING	LEAD FINISH
Other characteristics will be standard as described on this data sheet. If special characteristics are required, such as: special linearity tolerance, special resistance tolerance, extra taps, non-linear functions, etc., please state these on your order and allow additional lead time for delivery.				

SAP PART NUMBERING GUIDELINES			
<b>162</b>	<b>B</b>	<b>103</b>	<b>B05</b>
MODEL	STYLE	OHMIC VALUE	PACKAGING

## 1/2" (12.7 mm) Ten Turn Wirewound Bushing Mount Precision Potentiometer

Vishay Spectrol

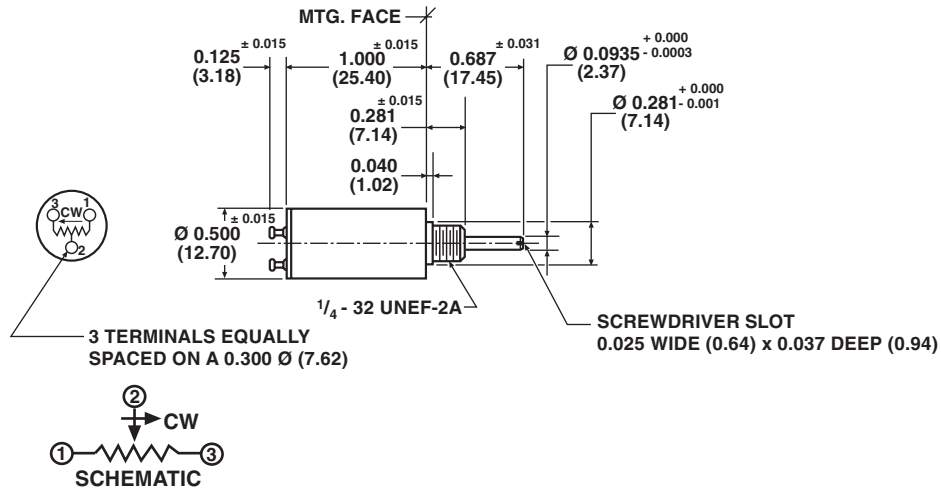
**DIMENSIONS** in inches (millimeters)

TOLERANCES: UNLESS OTHERWISE NOTED.  
DECIMALS ± 0.005 ANGLES ± 2°

MECHANICAL SPECIFICATIONS		
PARAMETER		
Mechanical Rotation		3600°, + 15° - 0°
Bearing Type:		<b>Sleeve</b>
Torque (Maximum)	<b>STARTING</b>	0.8 oz. - in (57.60 g - cm)
	<b>RUNNING</b>	0.6 oz. - in (43.20 g - cm)
Mechanical Runouts (Maximums):		
Shaft (TIR)		0.003" (0.08 cm)
Pilot Dia. (TIR)		0.003" (0.08 cm)
Lateral (TIR)		0.005" (0.13 cm)
Shaft End Play		0.010" (0.25 cm)
Shaft Radial Play		0.003" (0.08 cm)
Weight		0.3 oz. (8.50 g) maximum
Stop Strength		20 oz. - in (static) (1.44 kg - cm)

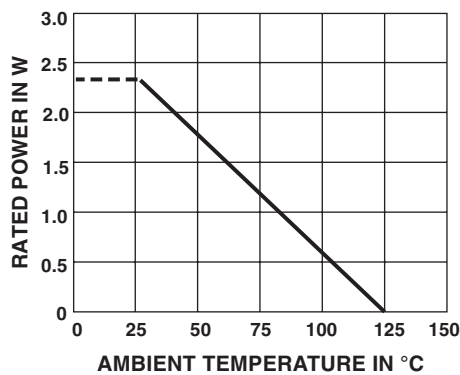
**POWER RATING CHART**

RESISTANCE ELEMENT DATA					
STANDARD RESISTANCE VALUES (Ω)	RESOLUTION (%)	OHMS PER TURN	MAXIMUM CURRENT AT 40 °C AMBIENT (mA)	MAXIMUM VOLTAGE ACROSS COIL (V)	WIRE TEMP. COEF. (ppm/°C)
100	0.092	0.092	141	14	20
200	0.069	0.138	100	20	20
500	0.049	0.245	63	32	20
1K	0.047	0.470	45	45	20
2K	0.038	0.763	32	64	20
5K	0.031	1.56	20	100	20
10K	0.025	2.55	14	140	20
20K	0.020	3.94	10	200	20
30K	0.018	5.34	8.2	246	20
50K	0.015	7.64	6.3	315	20
100K	0.013	13.2	4.5	450	20

## 1/2" (12.7 mm) Ten Turn Wirewound Servo Mount Precision Potentiometer



### FEATURES

- Large range of ohmic values: 100 Ω to 100 kΩ
- Smallest size available on the market
- Very easy and accurate adjustment



ELECTRICAL SPECIFICATIONS		
PARAMETER		
Total Resistance Standard Range Tolerance	<b>STANDARD</b> 100 Ω to 100 kΩ ± 5 %	<b>SPECIAL</b> 115 kΩ ± 1 %
Linearity (Independent)	<b>STANDARD</b> ± 0.30 %	<b>BEST PRACTICAL</b> ± 0.15 %
Noise	100 Ω ENR	
Rotation	3600° + 15° - 0°	
Power Rating: Section 1:	2.0 W at 40 °C ambient, derated to zero at 125 °C	
Insulation Resistance	100 MΩ minimum, 500 V <sub>DC</sub>	
Dielectric Strength	500 V <sub>RMS</sub> , 60 Hz	
Absolute Minimum Resistance	Linearity x total resistance or 0.5 Ω, whichever is greater	
End Voltage	Linearity x total applied voltage for total resistance above 20 Ω, 2.0 % of total applied voltage for 20 Ω and below	

MATERIAL SPECIFICATIONS	
Housing and Lids	Molded, glass filled, thermoset plastic
Front Lid	Aluminum, anodized
Shaft	Stainless steel, non-passivated
Terminals	Brass, plated for solderability

ENVIRONMENTAL SPECIFICATIONS	
Vibration	15 g thru 2000 Hz
Shock	50 g
Salt Spray	48 h
Rotational Life	500 000 shaft revolutions
Temperature Range	- 55 °C to + 125 °C

MARKING	
Unit Identification	Units shall be marked with Vishay Spectrol name and model no, resistance and resistance tolerance, linearity, terminal identification and date code

ORDERING INFORMATION/DESCRIPTION				
The Model 164 can be ordered from this data sheet with a variety of alternate characteristics, as shown. For most rapid service on your order, please state:				
<b>164</b> MODEL	<b>S</b> STYLE (SERVO)	<b>10K</b> TOTAL RESISTANCE	<b>B05</b> PACKAGING	<b>e4</b> LEAD FINISH
Other characteristics will be standard as described on this data sheet. If special characteristics are required, such as: special linearity tolerance, special resistance tolerance, extra taps, non-linear functions, etc., please state these on your order and allow additional lead time for delivery.				

SAP PART NUMBERING GUIDELINES			
<b>164</b> MODEL	<b>S</b> STYLE	<b>103</b> OHMIC VALUE	<b>B05</b> PACKAGING



**1/2" (12.7 mm) Ten Turn Wirewound  
Servo Mount Precision Potentiometer**

Vishay Spectrol

**DIMENSIONS** in inches (millimeters)

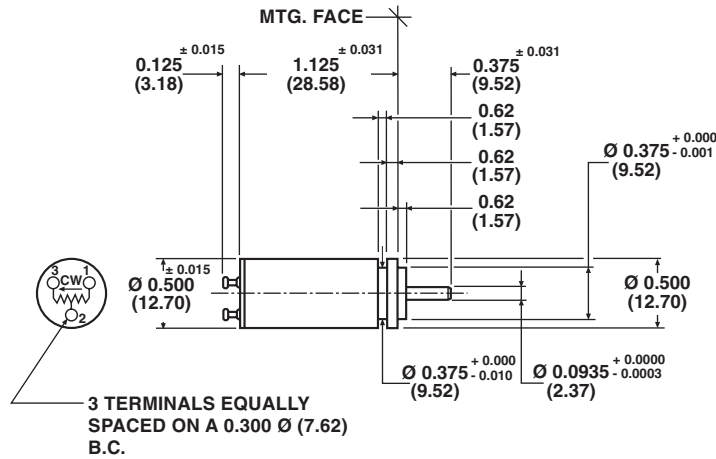

TOLERANCES: UNLESS OTHERWISE NOTED.  
DECIMALS ± 0.005 ANGLES ± 2°

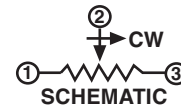

MECHANICAL SPECIFICATIONS		
PARAMETER		
Mechanical Rotation		3600°, + 15° - 0°
Bearing Type		<b>Ball</b>
Torque (Maximum)	<b>STARTING</b>	0.4 oz. - in (28.80 g - cm)
	<b>RUNNING</b>	0.3 oz. - in (21.60 g - cm)
Mechanical Runouts (Maximums):		
Shaft (TIR)		0.002" (0.05 cm)
Pilot Dia. (TIR)		0.003" (0.08 cm)
Lateral (TIR)		0.003" (0.08 cm)
Shaft End Play		0.005" (0.13 cm)
Shaft Radial Play		0.002" (0.05 cm)
Weight		0.3 oz. (8.50 g) maximum
Stop Strength		20 oz. - in (static) (1.44 kg - cm)

**POWER RATING CHART**

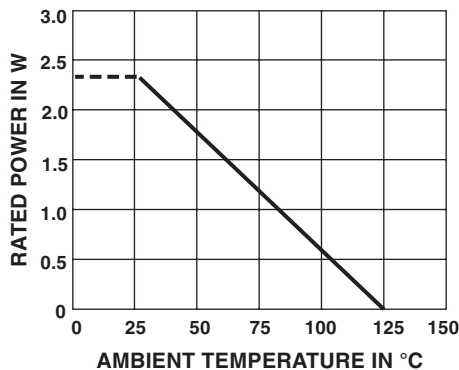

RESISTANCE ELEMENT DATA					
STANDARD RESISTANCE VALUES (Ω)	RESOLUTION (%)	OHMS PER TURN	MAXIMUM CURRENT AT 40 °C AMBIENT (mA)	MAXIMUM VOLTAGE ACROSS COIL (V)	WIRE TEMP. COEF. (ppm/°C)
100	0.092	0.092	141	14	20
200	0.069	0.138	100	20	20
500	0.049	0.245	63	32	20
1K	0.047	0.470	45	45	20
2K	0.038	0.763	32	64	20
5K	0.031	1.56	20	100	20
10K	0.025	2.55	14	140	20
20K	0.020	3.94	10	200	20
30K	0.018	5.34	8.2	246	20
50K	0.015	7.64	6.3	315	20
100K	0.013	13.2	4.5	450	20

## 7/8" (22.2 mm) Ten-Turn Wirewound Upper Grade Precision Potentiometer



### FEATURES

- Bushing mount and servo mount designs are available
- Large ohmic value range: 15 Ω to 100 kΩ
- Dual gang configuration
- Improved linearity available
- Long life > 2 million shaft revolutions

ELECTRICAL SPECIFICATIONS		
PARAMETER	STANDARD	SPECIAL
Total Resistance Tolerance: 100 Ω and above Below 100 Ω	15 Ω to 100 kΩ ± 3 % ± 5 %	15 Ω to 150 kΩ ± 1 % ± 3 %
Linearity (Independent) 15 Ω to 50 Ω 50 Ω to 1 kΩ 1 kΩ to 5 kΩ 5 kΩ and Above	STANDARD ± 0.25 % ± 0.25 % ± 0.25 % ± 0.25 %	BEST PRACTICAL ± 0.15 % ± 0.10 % ± 0.075 % ± 0.05 %
Noise	100 Ω ENR	
Electrical Rotation	3600° + 4° - 0°	
Power Rating: Additional Sections	2.0 W at 70 °C ambient derated to zero at 125 °C 75 % of the rating of section 1 (1.5 W at 70 °C)	
Insulation Resistance	1000 MΩ minimum 500 V <sub>DC</sub>	
Dielectric Strength	1000 V <sub>RMS</sub> , 60 Hz	
Absolute Minimum Resistance	Linearity x total resistance or 0.5 Ω whichever is greater	
End Voltage	Linearity x total applied voltage for total resistance above 20 Ω, 2.0 % of applied voltage for 20 Ω and below	
Phasing (CCW End Points)	Additional sections phased to section 1 within ± 2°	
Taps (Extra)	54 available as special, standard tolerance ± 2°	

ORDERING INFORMATION/DESCRIPTION					
The Model 502 can be ordered from this data sheet with a variety of alternate characteristics, as shown above. For most rapid service on your order, please state:					
502	S	2	10K	20K	BO1
MODEL	STYLE	NUMBER OF SECTIONS	TOTAL RESISTANCE OF EACH SECTION		PACKAGING
	B: Bushing S: Servo	1 or 2	Beginning with the section nearest the mounting end		Box of 1 piece
Other characteristics will be standard as described on this data sheet. If special characteristics are required, such as: special linearity tolerance, special resistance tolerance, extra taps, non-linear functions, etc., please state these on your order and allow additional lead time for delivery.					

SAP PART NUMBERING GUIDELINES					
502	S	2	103	203	B01
MODEL	STYLE	NUMBER OF SECTIONS	OHMIC VALUE SECTION N° 1	OHMIC VALUE SECTION N° 2	PACKAGING

**7/8" (22.2 mm) Ten-Turn Wirewound  
Upper Grade Precision Potentiometer**

Vishay Spectrol

**DIMENSIONS** in inches (millimeters)

**BUSHING MOUNT**

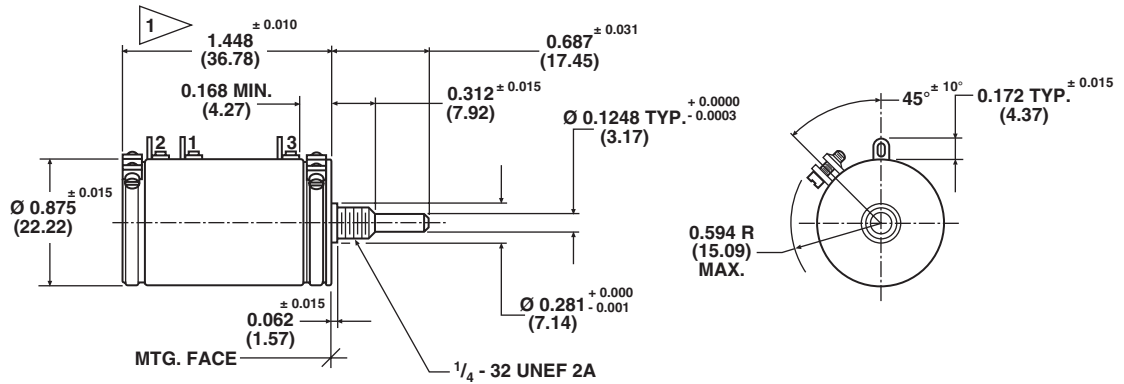

**SERVO MOUNT**

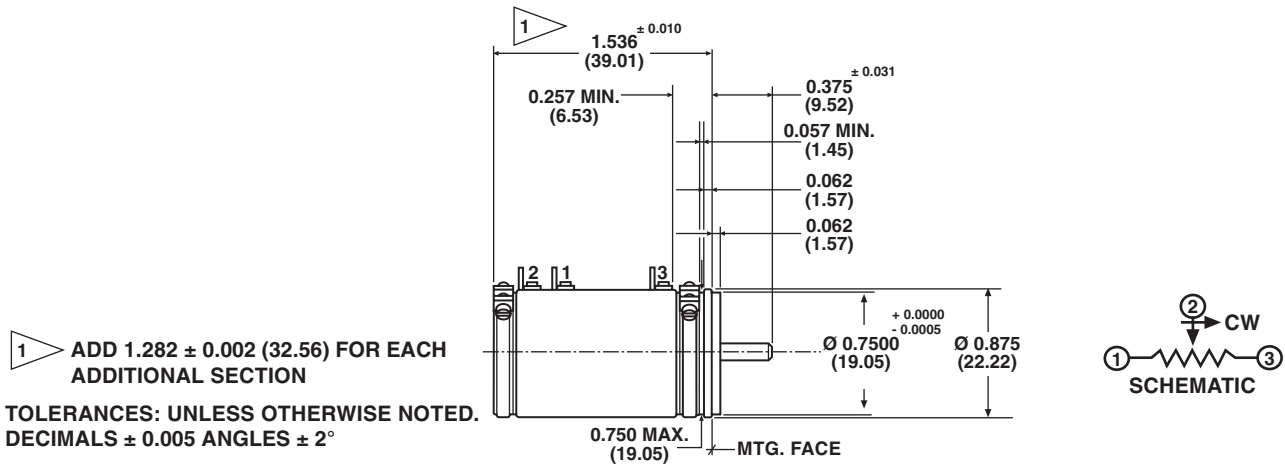

**TOLERANCES: UNLESS OTHERWISE NOTED.  
DECIMALS ± 0.005 ANGLES ± 2°**

<b>MECHANICAL SPECIFICATIONS</b>		
<b>PARAMETER</b>		
Rotation	3600° + 10° - 0°	
Bearing Type	<b>SERVO</b> Ball bearing	<b>BUSHING MOUNT</b> Sleeve bearing
Torque (Maximums)	<b>STARTING</b>	<b>RUNNING</b>
Servo Section 1	0.4 oz. - in (28.8 g - cm)	0.3 oz. - in (21.6 g - cm)
Bushing Section 1	0.5 oz. - in (36.0 g - cm)	0.4 oz. - in (28.8 g - cm)
Each Additional Section	0.3 oz. - in (21.6 g - cm)	0.2 oz. - in (14.4 g - cm)
Mechanical Runout (Maximums):	<b>SERVO</b>	<b>BUSHING</b>
Shaft Runout (TIR)	0.002" (0.05 cm)	0.002" (0.05 cm)
Pilot Dia. Runout (TIR)	0.002" (0.05 cm)	0.002" (0.05 cm)
Lateral Runout (TIR)	0.002" (0.05 cm)	0.005" (0.13 cm)
Shaft End Play	0.005" (0.13 cm)	0.005" (0.13 cm)
Shaft Radial Play	0.002" (0.05 cm)	0.003" (0.08 cm)
Weight:		
Single Section	1.20 oz. (34.0 g)	
Each Additional Section	0.80 oz. (22.7 g)	
Stop Strength	100 oz. - in, static (7.2 kg - cm)	
Ganging	2 sections, terminal alignment, added sections, within ± 10° of section 1 terminals	
Moment of Inertia	0.45 g - cm <sup>2</sup> per section maximum	

# Model 502



Vishay Spectrol

$\frac{7}{8}$ " (22.2 mm) Ten-Turn Wirewound  
Upper Grade Precision Potentiometer

MATERIAL SPECIFICATIONS	
Housing	Phenolic (black) glass filled
Lids	Aluminum, anodized
Shaft	Stainless steel, non-magnetic, non-passivated
Terminals	Brass, plated for solderability
Clamp Ring	Stainless steel
Bushing Mounting Hardware Lockwasher Internal Tooth: Panel Nut:	Steel, nickel plated Brass, nickel plated

MARKING	
Unit Identification	Units shall be marked with Vishay spectrol name and model no, resistance and resistance tolerance, linearity, terminal identification, and date code

ENVIRONMENTAL SPECIFICATIONS	
Vibration	15 g thru 2000 CPS
Shock	50 g
Salt Spray	96 h
Rotational Life	2 million shaft revolutions
Load Life	900 h
Operating Temperature Range	- 55 °C to + 125 °C

## POWER RATING CHART

(Ratings for cup No. 1.

Additional cups 75 % of values shown)

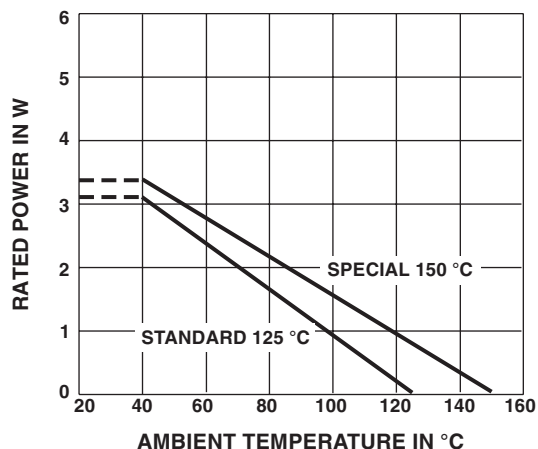

RESISTANCE ELEMENT DATA					
STANDARD RESISTANCE VALUES (Ω)	RESOLUTION (%)	OHMS PER TURN	MAXIMUM CURRENT AT 70 °C AMBIENT (mA)	MAXIMUM VOLTAGE ACROSS COIL (V)	WIRE TEMP. COEF. (ppm/°C)
15	0.088	0.013	365	5.48	800
20	0.066	0.013	316	6.32	800
50	0.050	0.025	200	10.0	800
100	0.050	0.050	141	14.1	180
200	0.049	0.098	100	20.0	20
500	0.037	0.185	63.2	31.6	20
1K	0.034	0.339	44.7	44.7	20
2K	0.029	0.571	31.6	63.2	20
5K	0.023	1.173	20.0	100	20
10K	0.017	1.731	14.1	141	20
20K	0.016	3.142	10.0	200	20
50K	0.011	5.639	6.32	316	20
100K	0.010	10.325	4.47	447	20
150K	0.010	14.170	3.65	548	20

## 7/8" (22.2 mm) Multiturn Wirewound

### 533: 3 Turns/534: 10 Turns/535: 5 Turns

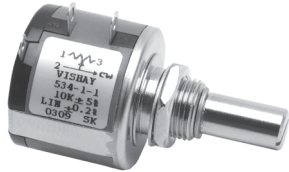
**Note**

- The color of this product may either be black (US market) or blue (other regions)

**FEATURES**

- Bushing and servo mount designs available
- Special resistance tolerances to 1 %
- Rear shaft extensions and support bearing
- Metric shaft available
- Dual gang configuration and concentric shafts
- High torque, center tap, slipping clutch on request
- Special markings and front shaft extensions

**RoHS**  
COMPLIANT

<b>ELECTRICAL SPECIFICATIONS</b>			
PARAMETER	MODEL 533	MODEL 534	MODEL 535
Resistance Range - Standard Values	50 Ω to 20 kΩ	100 Ω to 100 kΩ	50 Ω to 50 kΩ
Capability Range	5 Ω to 60 kΩ	10 Ω to 200 kΩ	5 Ω to 100 kΩ
Standard Tolerance	± 5 %	± 5 %	± 5 %
Linearity (Independent)	± 0.25 %	± 0.20 %	± 0.25 %
Noise	100 Ω ENR	100 Ω ENR	100 Ω ENR
Rotation (Electrical and Mechanical)	1080° +10° -0°	3600° +10° -0°	1800° +10° -0°
Power Rating (at 70 °C)	1.0 W	2.0 W	1.5 W
Insulation Resistance	1000 MΩ minimum 500 V <sub>DC</sub>		
Dielectric Strength	1000 V <sub>RMS</sub> minimum 60 Hz		
Absolute Minimum Resistance	Not to exceed linearity x total resistance or 1 Ω, whichever is greater		
Temperature Coefficient	20 ppm/°C (standard values, wire only)		
End Voltage	0.25 % of total applied voltage, maximum		
Phasing	CCW end points - section 2 phased to section 1 within ± 2°		
Taps	Center tap only		

<b>MARKING</b>	
<b>Unit Identification</b>	Manufacturer's name and model number, resistance value and tolerance, linearity specification date code and terminal identification

<b>RESISTANCE VALUES</b>	
<b>Ohms 533:</b>	50R, 100R, 200R, 500R, 1K, 2K, 5K, 10K, 20K
<b>534:</b>	100R, 200R, 500R, 1K, 2K, 5K, 10K, 20K, 50K, 100K
<b>535:</b>	50R, 100R, 200R, 500R, 1K, 2K, 5K, 10K, 20K, 50K

<b>ORDERING INFORMATION/DESCRIPTION</b>								
The Models 533 (3 turns), 534 (10 turns) and 535 (5 turns) can be ordered by stating								
<b>534</b>	<b>B</b>	<b>2</b>	<b>10K</b>	<b>20K</b>	<b>5 %</b>	<b>L</b>	<b>BO10</b>	<b>e4</b>
MODEL	MOUNTING	NUMBER OF SECTIONS	OHMIC VALUE SECTION N° 1	OHMIC VALUE SECTION N° 2	TOLERANCE ON OHMIC VALUE	LINEARITY ± 0.20 %	PACKAGING Box of 10 pieces	LEAD FINISH
	<b>B:</b> Bushing <b>S:</b> Servo							

<b>SAP PART NUMBERING GUIDELINES</b>							
<b>534</b>	<b>B</b>	<b>2</b>	<b>103</b>	<b>203</b>	<b>J</b>	<b>L</b>	<b>B10</b>
MODEL	STYLE	NUMBER OF SECTIONS	OHMIC VALUE SECTION N° 1	OHMIC VALUE SECTION N° 2	TOLERANCE ON OHMIC VALUE	LINEARITY	PACKAGING
	<b>B:</b> Bushing <b>S:</b> Servo		103 = 10K	203 = 20K	<b>J:</b> ± 5 % <b>F:</b> ± 1 %	<b>L:</b> ± 0.20 % <b>C:</b> ± 0.25 % <b>D:</b> ± 0.10 %	Box of 10 pieces



# Model 533, 534, 535



Vishay Spectrol

7/8" (22.2 mm) Multiturn Wirewound  
533: 3 Turns/534: 10 Turns/535: 5 Turns

## SINGLE SECTION DIMENSIONS in inches (millimeters)

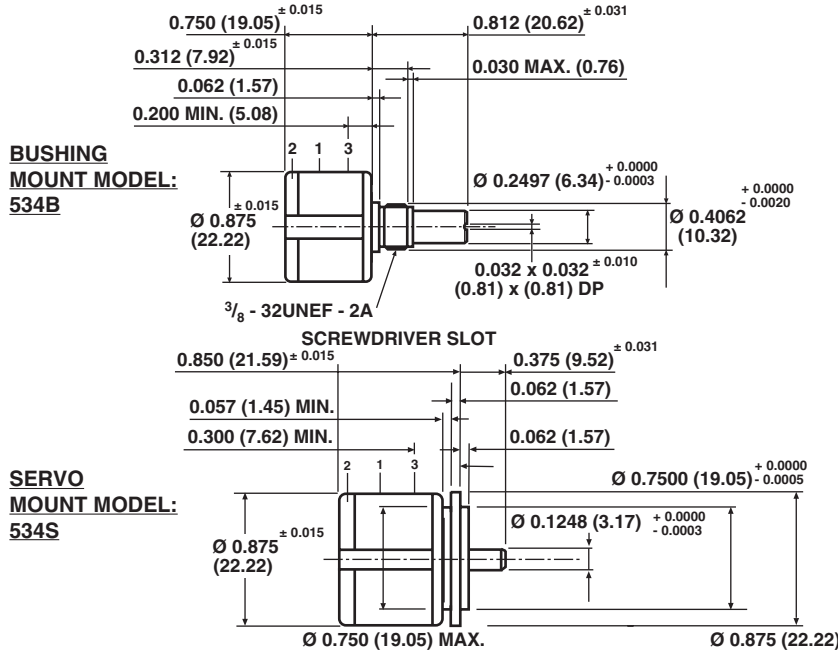

Mounting hardware, washer and panel nut, nickel plated

MECHANICAL SPECIFICATIONS		
PARAMETER		
Bearing Type	Bushing: Sleeve bearing	Servo: Ball bearing
Torque (Maximums): Starting		
Section 1	<b>534</b> 0.5 oz. - in (36 g - cm)	<b>533/535</b> 0.7 oz. - in (50 g - cm)
Section 2	0.9 oz. - in (65 g - cm)	1.1 oz. - in (79 g - cm)
Torque (Maximums): Running		
Section 1	<b>534</b> 0.4 oz. - in (28.80 g - cm)	<b>533/535</b> 0.6 oz. - in (43.20 g - cm)
Section 2	0.7 oz. - in (50.40 g - cm)	0.9 oz. - in (64.8 g - cm)
Weight (Maximums)		
Section 1	0.75 oz. (21.26 g)	
Section 2	1.25 oz. (35.44 g)	
Stop Strength	75 oz. - in (static) (5.4 kg - cm)	
Ganging	2 sections maximum	

## POWER RATING CHART

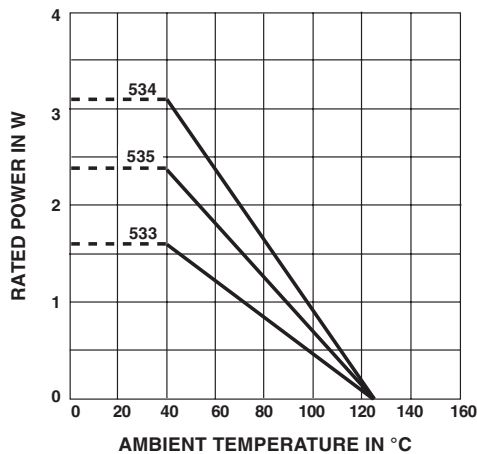

## ENVIRONMENTAL SPECIFICATIONS

Vibration	15 g thru 2000 Hz
Shock	50 g
Rotational Life (Shaft Revolution)	
533	300 000
534	1 000 000
534 (Servo)	> 1 000 000
535	500 000
Load Life	900 h
Temperature Range	- 55 °C to + 125 °C



<b>RESISTANCE ELEMENT DATA</b>														
RESISTANCE VALUE ( $\Omega$ )			RESOLUTION %			OHMS PER TURN			MAX CURRENT AT 70 °C AMBIENT (mA)			MAX VOLTAGE ACROSS COIL (V)		
533	534	535	533	534	535	533	534	535	533	534	535	533	534	535
50	-	50	0.149	-	0.120	0.0746	-	0.0603	141.0	-	173.0	7.07	-	8.66
100	100	100	0.111	0.060	0.075	0.1114	0.0603	0.0746	100.0	141.0	122.0	10.0	14.1	12.2
200	200	200	0.097	0.037	0.061	0.1954	0.0746	0.1220	70.7	100.0	86.6	14.1	20.0	17.3
500	500	500	0.069	0.031	0.049	0.3424	0.1520	0.2459	44.7	63.2	54.7	22.4	31.6	27.4
1K	1K	1K	0.063	0.025	0.041	0.6331	0.2459	0.4113	31.6	44.7	38.7	31.6	44.7	38.7
2K	2K	2K	0.041	0.021	0.031	0.8206	0.4113	0.6331	22.4	31.6	27.4	44.7	63.2	54.8
5K	5K	5K	0.044	0.016	0.034	2.2330	0.8206	1.7230	14.1	20.0	17.3	70.7	100.0	86.6
10K	10K	10K	0.034	0.017	0.030	3.4510	1.7230	3.0160	10.0	14.1	12.2	100.0	141.0	122.0
20K	20K	20K	0.031	0.015	0.020	6.1790	3.0160	3.9910	7.07	10.0	8.66	141.0	200.0	173.0
-	50K	50K	-	0.009	0.015	-	4.6690	7.4560	-	6.32	5.47	-	316.0	274.0
-	100K	-	-	0.007	-	-	7.4560	-	-	4.47	-	-	447.0	-
-	-	-	-	-	-	-	-	-	-	-	-	-	-	-
-	-	-	-	-	-	-	-	-	-	-	-	-	-	-

## 7/8" (22.2 mm) Ten Turn Wirewound Precision Potentiometer with a Plastic Shaft



### FEATURES

- 10 standard resistance values
- Plastic shaft
- Rugged integrated construction
- 0.20 % linearity



ELECTRICAL SPECIFICATIONS	
PARAMETER	
Total Resistance	Range 100 Ω to 100 kΩ, tolerance ± 5 %
Linearity (Independent)	± 0.20 %
Noise	100 Ω ENR maximum
Electrical Angle	3600° +10° - 0°
Power Rating	2.0 W at 70 °C derated to zero at 125 °C
Insulation Resistance	1000 MΩ minimum 500 V <sub>DC</sub>
Dielectric Strength	1000 V <sub>RMS</sub> , 60 Hz
Absolute Minimum Resistance	Not to exceed 0.10 % of total resistance or 1 Ω whichever is greater
Temperature Coefficient	20 ppm/°C (wire only)
End Voltage	0.25 % of total applied voltage maximum

ORDERING INFORMATION/DESCRIPTION				
536	B	10K	BO10	e4
MODEL	MOUNTING	OHMIC VALUE	PACKAGING	LEAD FINISH
	B: Bushing		Box of 10 pieces	

SAP PART NUMBERING GUIDELINES			
536	B	103	B10
MODEL	STYLE	OHMIC VALUE	PACKAGING



**7/8" (22.2 mm) Ten Turn Wirewound  
Precision Potentiometer with a Plastic Shaft**

Vishay Spectrol

**DIMENSIONS** in inches (millimeters)

**BUSHING MOUNT**

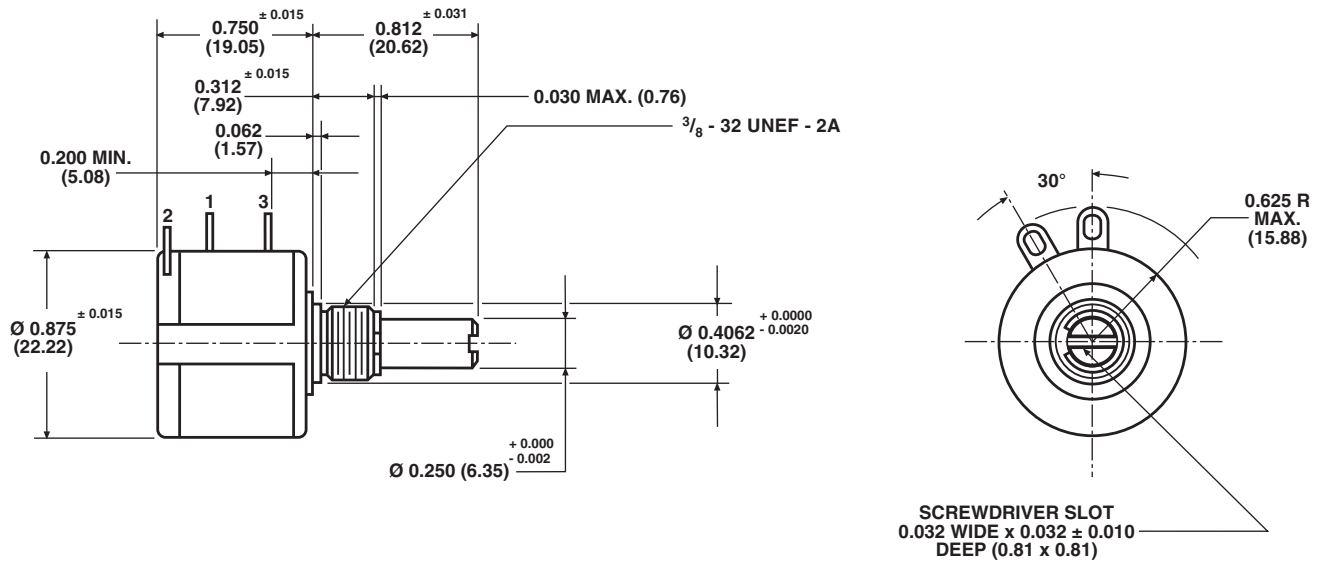

**METRIC SHAFT/BUSHING THREAD**

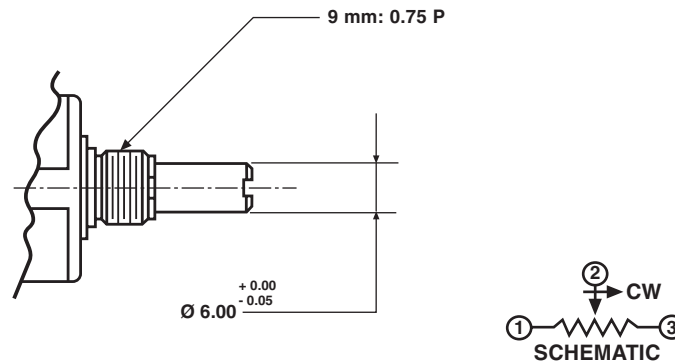

**TOLERANCES: UNLESS OTHERWISE NOTED.  
DECIMALS ± 0.005 ANGLES ± 2°**

<b>MECHANICAL SPECIFICATIONS</b>		
<b>PARAMETER</b>		
Rotation	3600° + 10° - 0°	
Torque (Maximums)	<b>STARTING</b> 0.5 oz. - in (36.00 g - cm)	<b>RUNNING</b> 0.4 oz. - in (28.80 g - cm)
Mechanical Runouts		
Shaft (TIR)	0.005" (0.13 cm)	
Pilot Dia. (TIR)	0.003" (0.08 cm)	
Lateral Runout (TIR)	0.005" (0.13 cm)	
Shaft End Play	0.010" (0.25 cm)	
Shaft Radial Play	0.005" (0.13 cm)	
Weight (Maximum)	0.75 oz. (21.26 g)	
Stop Strength	75 oz. - in (static) (5.4 kg - cm)	

# Model 536



Vishay Spectrol

7/8" (22.2 mm) Ten Turn Wirewound  
Precision Potentiometer with a Plastic Shaft

MATERIAL SPECIFICATIONS	
Front Lid	Stainless steel and nickel plated brass bushing
Housing	Thermoplastic nylon glass filled
Rear Lid	Thermo-glass filled
Shaft	Thermo-glass filled
Terminals	Brass plated for solderability
Mounting Hardware Lockwasher Internal Tooth: Panel Nut:	Steel nickel plated Brass, nickel plated

ENVIRONMENTAL SPECIFICATIONS	
Vibration	15 g thru 2000 Hz
Shock	50 g
Rotational Life	1 million shaft revolutions
Load Life	900 h
Operating Temperature Range	- 55 °C to + 125 °C

## POWER RATING CHART

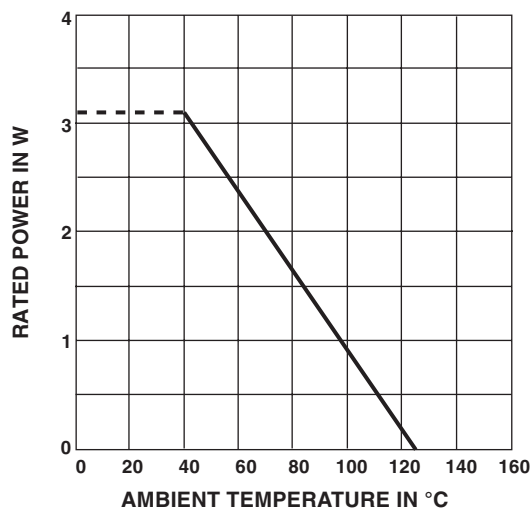

RESISTANCE ELEMENT DATA				
RESISTANCE VALUES (Ω)	RESOLUTION (%)	OHMS PER TURN	MAXIMUM CURRENT AT 70 °C AMBIENT (mA)	MAXIMUM VOLTAGE ACROSS COIL (V)
100	0.060	0.0603	141.0	14.1
200	0.037	0.0746	100.0	20.0
500	0.031	0.1520	63.2	31.6
1K	0.025	0.2459	44.7	44.7
2K	0.021	0.4113	31.6	63.2
5K	0.016	0.8206	20.0	100.0
10K	0.017	1.7230	14.1	141.0
20K	0.015	3.0160	10.0	200.0
50K	0.009	4.6690	6.32	316.0
100K	0.007	7.4560	4.47	447.0

MARKING	
Unit Identification	Units shall be marked with Vishay Spectrol name and model no, resistance, resistance tolerance, linearity, terminal identification and date code

## 7/8" (22.2 mm) Three Turn Wirewound Upper Grade Precision Potentiometer



### FEATURES

- Large range of ohmic values: 5 Ω to 20 kΩ
- Bushing mount or servo mount designs are available
- Gangable up to 3 sections
- Extra taps available upon request

<b>ELECTRICAL SPECIFICATIONS</b>		
PARAMETER		
Total Resistance	<b>STANDARD RANGE</b> 5 Ω to 20 kΩ	<b>SPECIAL</b> 45 kΩ
Tolerance 50 Ω and Above Below 50 Ω	± 3 % ± 5 %	± 1 % ± 3 %
Linearity (Independent) Total Resistance 5 Ω to 500 Ω 500 Ω to 2 kΩ 2 kΩ and Above	<b>STANDARD</b>  ± 0.25 % ± 0.25 % ± 0.25 %	<b>BEST PRACTICAL</b>  ± 0.25 % ± 0.20 % ± 0.125 %
Noise	100 Ω ENR	
Electrical Rotation	1080° + 4° - 0°	
Power Rating Section 1 Additional Section	1.0 W at 70 °C ambient to zero at 125 °C 75 % of the rating of section 1 (0.75 W at 70 °C)	
Insulation Resistance	1000 MΩ minimum, 500 V <sub>DC</sub>	
Dielectric Strength	1000 V <sub>RMS</sub> minimum, 60 Hz	
Absolute Minimum Resistance	Linearity x total resistance or 0.5 Ω, whichever is greater	
End Voltage	Linearity x total applied voltage for total resistance above 20 Ω, 2.0 % of total applied voltage for 20 Ω and below	
Phasing (CCW End Points)	Additional sections phased to section 1 within ± 2°	
Taps (Extra)	16 available as special, standard tolerance ± 2°	

<b>ORDERING INFORMATION/DESCRIPTION</b>				
The Model 552 can be ordered from this data sheet with a variety of alternate characteristics, as shown. For most rapid service on your order, please state:				
<b>552</b> MODEL	<b>B</b> MOUNTING	<b>1</b> NUMBER OF SECTIONS	<b>10K</b> OHMIC VALUE OF SECTION N° 1	<b>BO1</b> PACKAGING
	<b>B:</b> Bushing <b>S:</b> Servo	From 1 up to 3		Box of 1 piece
Other characteristics will be standard as described on this data sheet. If special characteristics are required, such as: special linearity tolerance, special resistance tolerance, extra taps, non-linear functions, etc., please state these on your order and allow additional lead time for delivery.				

<b>SAP PART NUMBERING GUIDELINES</b>				
<b>552</b> MODEL	<b>B</b> STYLE	<b>1</b> NUMBER OF SECTIONS	<b>103</b> OHMIC VALUE OF SECTION N° 1	<b>B01</b> PACKAGING

# Model 552

Vishay Spectrol

7/8" (22.2 mm) Three Turn Wirewound  
Upper Grade Precision Potentiometer



## DIMENSIONS in inches (millimeters)

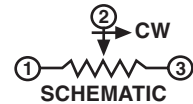
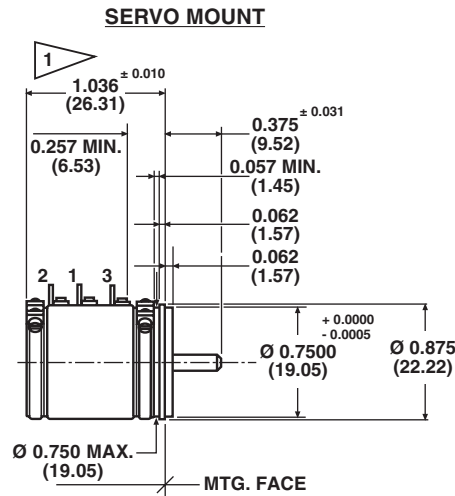
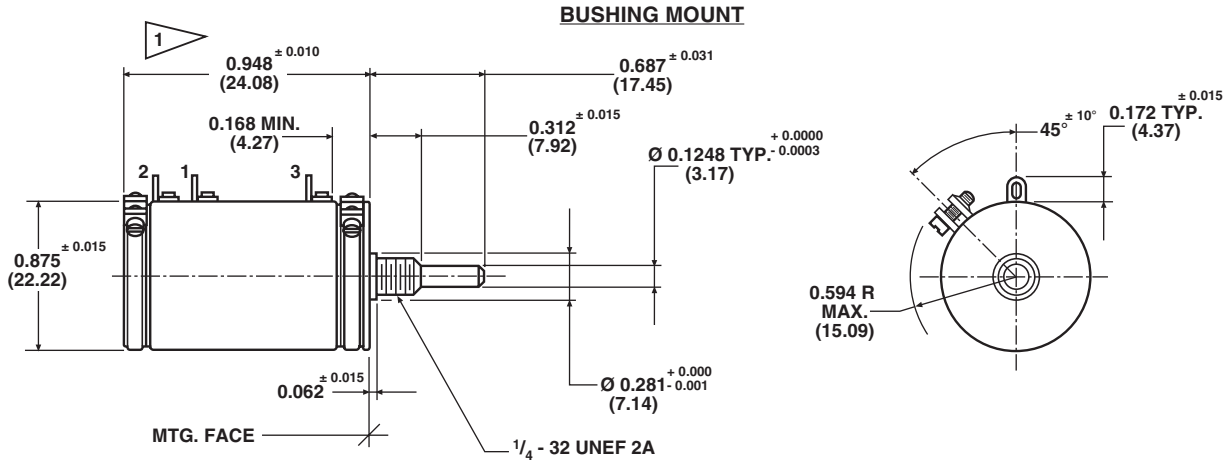

TOLERANCES: UNLESS OTHERWISE NOTED.  
DECIMALS ± 0.005 ANGLES ± 2°

ADD 0.782 ± 0.002 (19.86) FOR EACH  
ADDITIONAL SECTION

MECHANICAL SPECIFICATIONS		
PARAMETER		
Mechanical Rotation	1080° + 10° - 0°	
Bearing Type: Servo Mount Bushing Mount	Ball bearing Sleeve bearing	
Torque (Maximum) Servo: 1 Section Bushing: 1 Section Each Additional Section	<b>STARTING</b> 0.4 oz. - in (28.8 g - cm) 0.5 oz. - in (36.0 g - cm) 0.3 oz. - in (21.6 g - cm)	<b>RUNNING</b> 0.3 oz. - in (21.6 g - cm) 0.4 oz. - in (28.8 g - cm) 0.2 oz. - in (14.4 g - cm)
Mechanical Runouts (Maximum) Shaft Runout (TIR/in) Pilot Dia. Runout (TIR) Lateral Runout (TIR) Shaft End Play Shaft Radial Play	<b>SERVO</b> 0.002" (0.05 cm) 0.002" (0.05 cm) 0.002" (0.05 cm) 0.005" (0.13 cm) 0.002" (0.05 cm)	<b>BUSHING</b> 0.002" (0.05 cm) 0.002" (0.05 cm) 0.005" (0.13 cm) 0.005" (0.13 cm) 0.003" (0.08 cm)
Weight (Maximum): Single Section Additional Section	0.75 oz. (21.7 g) 0.60 oz. (17.0 g)	
Stop Strength	100 oz. - in static (7.2 kg - cm)	
Ganging	3 sections maximum, terminal alignment added sections within ± 10° of section 1 terminals	
Moment of Inertia	0.30 g - cm <sup>2</sup> per section maximum	



**7/8" (22.2 mm) Three Turn Wirewound  
Upper Grade Precision Potentiometer**

Vishay Spectrol

MATERIAL SPECIFICATIONS	
Housing	Glass filled phenolic (black)
Lids	Aluminum, anodized
Shaft	Stainless steel, non magnetic, non-passivated
Terminals	Brass, gold plated
Clamp Ring	Stainless steel
Bushing Mount Hardware Lockwasher Internal Tooth: Panel Nut:	Steel, nickel plated Brass, nickel plated

ENVIRONMENTAL SPECIFICATIONS	
Vibration	15 g thru 2000 Hz
Shock	50 g
Salt Spray	96 h
Rotational Life	600 000 shaft revolutions
Load Life	900 h
Operating Temperature Range	- 65 °C to + 125 °C

MARKING	
Unit Identification	Units will be marked with Vishay Spectrol name and model no, resistance and resistance tolerance, linearity, terminal identification, and date code

**POWER RATING CHART**

(Ratings for cup N<sup>o</sup> 1.  
Additional cups 75 % of values shown)

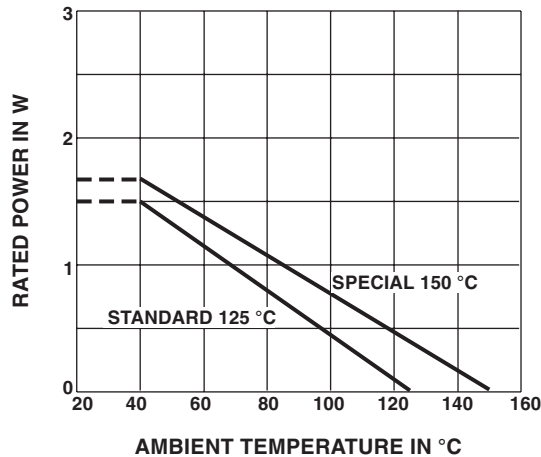

RESISTANCE ELEMENT DATA					
STANDARD RESISTANCE VALUES (Ω)	RESOLUTION (%)	OHMS PER TURN	MAXIMUM CURRENT AT 70 °C AMBIENT (mA)	MAXIMUM VOLTAGE ACROSS COIL (V)	WIRE TEMP. COEF. (ppm/°C)
5	0.265	0.013	447	2.24	800
10	0.182	0.018	316	3.16	800
20	0.155	0.031	224	4.48	800
50	0.150	0.075	141	7.05	180
100	0.125	0.125	100	10.0	20
200	0.116	0.232	70.7	14.1	20
500	0.103	0.517	44.7	22.4	20
1K	0.089	0.886	31.6	31.6	20
2K	0.071	1.411	22.4	44.8	20
5K	0.057	2.828	14.1	70.5	20
10K	0.044	4.381	10.0	100	20
20K	0.036	7.199	7.07	141	20
45K	0.031	14.170	4.71	212	20



### 1 13/16" (46 mm) Ten Turn Wirewound Upper Grade Precision Potentiometer



#### FEATURES

- Large range of ohmic values: 20  $\Omega$  to 200 k $\Omega$
- Bushing mount, servo mount and screw mount versions
- Gangable up to 3 sections
- Extra taps available upon request

ELECTRICAL SPECIFICATIONS		
PARAMETER		
Total Resistance Tolerance: 200 $\Omega$ and Above Below 200 $\Omega$	<b>STANDARD</b> 20 $\Omega$ to 200 k $\Omega$ $\pm 3\%$ $\pm 5\%$	<b>SPECIAL</b> 500 k $\Omega$ $\pm 1\%$ $\pm 3\%$
Linearity (Independent) 20 $\Omega$ to 50 $\Omega$ 50 $\Omega$ to 200 $\Omega$ 200 $\Omega$ and Above	<b>STANDARD</b> $\pm 0.25\%$ $\pm 0.25\%$ $\pm 0.25\%$	<b>SPECIAL</b> $\pm 0.15\%$ $\pm 0.10\%$ $\pm 0.05\%$
Noise	100 $\Omega$ ENR	
Electrical Rotation	3600° + 4° - 0°	
Power Rating Section 1 Each Additional Sections:	5.00 W 70 °C ambient, derated to zero at 125 °C 75 % of the rating of section 1 (3.8 W at 70 °C)	
Insulation Resistance	1000 M $\Omega$ minimum, 500 V <sub>DC</sub>	
Dielectric Strength	1000 V <sub>RMS</sub> , 60 Hz	
Absolute Minimum Resistance	Linearity x total resistance or 0.5 $\Omega$ , whichever is greater	
End Voltage	Linearity x total applied voltage for total resistance above 20 $\Omega$ , 2.0 % of total applied voltage for 20 and below	
Phasing (CCW End Points)	Additional sections phased to section 1 within $\pm 1^\circ$	
Taps (Extra)	Available as special, standard tolerance $\pm 1^\circ$	

ORDERING INFORMATION/DESCRIPTION				
Model 802 can be ordered from this data sheet with a variety of alternate characteristics, as shown above. For most rapid service on your order, please state:				
<b>802</b>	<b>S</b>	<b>1</b>	<b>10K</b>	<b>B01</b>
MODEL	MOUNTING	NUMBER OF SECTIONS	RESISTANCE OF EACH SECTION	PACKAGING
	<b>B:</b> Bushing <b>S:</b> Servo <b>C:</b> Screw	From 1 up to 3 max.	Beginning with the section nearest the mounting end	Box of 1 piece

SAP PART NUMBERING GUIDELINES				
<b>802</b>	<b>S</b>	<b>1</b>	<b>103</b>	<b>B01</b>
MODEL	STYLE	NUMBER OF SECTIONS	OHMIC VALUE OF SECTION N° 1	PACKAGING



**DIMENSIONS** in inches (millimeters)

**SERVO MOUNT**

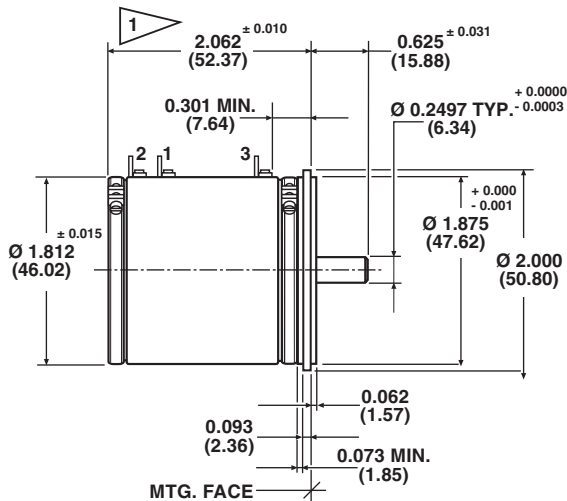

**BUSHING MOUNT**

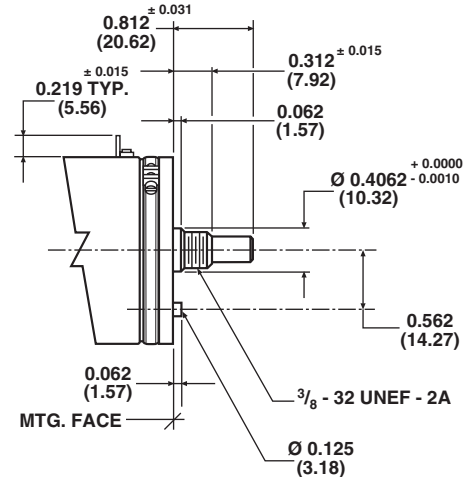

**SCREW MOUNT**

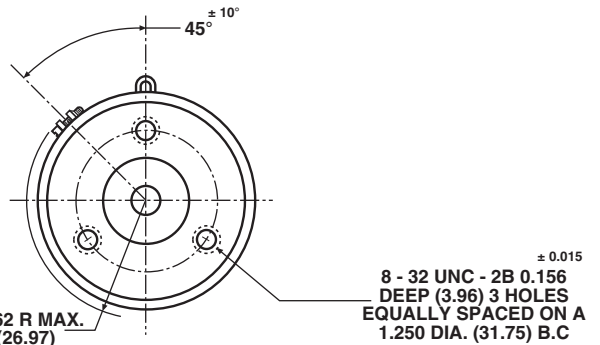
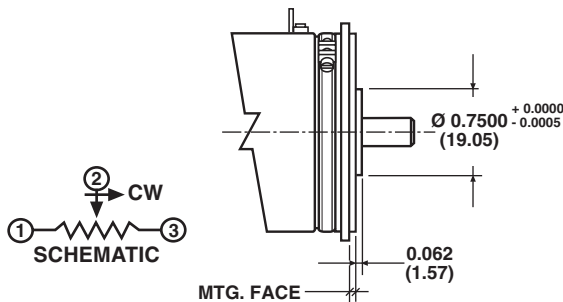

TOLERANCES: UNLESS OTHERWISE NOTED.  
DECIMALS ± 0.005 ANGLES ± 2°

1 ADD 1.770 ± 0.010 (44.96) FOR EACH ADDITIONAL SECTION

<b>MECHANICAL SPECIFICATIONS</b>			
PARAMETER			
Rotation	3600° + 10° - 0°		
Bearing Type	<b>SERVO</b> Ball bearing	<b>BUSHING</b> Sleeve	<b>SCREW</b> Ball bearing
Torque (Maximums) Servo or Screw Section 1 Bushing Section 1 Each Additional Section	<b>MAX STARTING</b> 1.20 oz. - in (86.4 g - cm) 1.75 oz. - in (126.0 g - cm) 0.80 oz. - in (57.6 g - cm)		<b>MAX RUNNING</b> 0.80 oz. - in (57.6 g - cm) 1.25 oz. - in (90.0 g - cm) 0.60 oz. - in (43.2 g - cm)
Mechanical Runouts (Maximums): Shaft (TIR/in) Pilot Dia. Runout (TIR) Lateral Runout (TIR) Shaft End Play Shaft Radial Play	<b>SERVO OR SCREW</b> 0.002" (0.05 cm) 0.002" (0.05 cm) 0.003" (0.08 cm) 0.005" (0.13 cm) 0.002" (0.05 cm)		<b>BUSHING</b> 0.002" (0.05 cm) 0.002" (0.05 cm) 0.005" (0.13 cm) 0.005" (0.13 cm) 0.003" (0.08 cm)
Weight: Single Section Each Additional Section	5.5 oz. (156 g) 3.7 oz. (105 g)		
Stop Strength	1000 oz. - in, static (72 kg - cm)		
Ganging	3 sections maximum terminal alignment, added sections within ± 10° of section 1 terminals		
Moment of Inertia	15 g - cm <sup>2</sup> per section maximum		

# Model 802



Vishay Spectrol

1 <sup>13</sup>/<sub>16</sub>" (46 mm) Ten Turn Wirewound  
Upper Grade Precision Potentiometer

MATERIAL SPECIFICATIONS	
Housing	Glass filled thermoset plastic
Lids	Aluminum, anodized
Shaft	Stainless steel, non-magnetic, non-passivated
Terminals	Brass, plated for solderability
Clamp Ring	Stainless steel
Bushing Mount Hardware Lockwasher: Panel Nut:	Internal tooth steel, nickel plated Brass, nickel plated

MARKING	
Unit Identification	Units shall be marked with Spectrol name and Model No, resistance and resistance tolerance, linearity, terminal identification, and date code

ENVIRONMENTAL SPECIFICATIONS	
Vibration	15 g thru 2000 CPS
Shock	50 g
Salt Spray	96 h
Rotational Life	2 million shaft revolutions
Load Life	900 h
Operating Temperature Range	- 55 °C to + 125 °C

## POWER RATING CHART

(Ratings for cup N<sup>o</sup> 1.  
Additional cups 75 % of values shown)

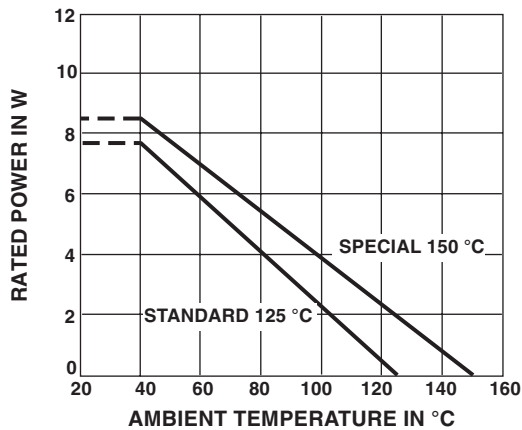

RESISTANCE ELEMENT DATA					
STANDARD RESISTANCE VALUES (Ω)	RESOLUTION (%)	OHMS PER TURN	MAXIMUM CURRENT AT 70 °C AMBIENT (mA)	MAXIMUM VOLTAGE ACROSS COIL (V)	WIRE TEMP. COEF. (ppm/°C)
20	0.044	0.009	500	10.0	800
50	0.027	0.014	316	15.8	800
100	0.024	0.024	224	22.4	800
200	0.028	0.056	158	31.6	180
500	0.023	0.115	100	50.0	20
1K	0.018	0.182	70.7	70.7	20
2K	0.020	0.402	50.0	100	20
5K	0.015	0.754	31.6	158	20
10K	0.013	1.229	22.4	224	20
20K	0.010	1.970	15.8	316	20
50K	0.007	3.686	10.0	500	20
100K	0.007	6.507	7.07	707	20
200K	0.005	6.929	5.00	1000	20
500K	0.004	19.987	2.00	1000	20

## 1 13/16" (46 mm) Three Turn Wirewound Bushing Mount



### FEATURES

- Gangable up to 2 sections
- Large range of ohmic values: 15 Ω to 50 kΩ
- Extra taps available upon request
- Ideally suits for all industry applications

<b>ELECTRICAL SPECIFICATIONS</b>		
PARAMETER	MODEL 830	
Total Resistance Standard Range Tolerance: 200 Ω and Above Below 200 Ω	15 Ω to 50 kΩ <b>STANDARD</b> ± 3 % ± 5 %	<b>SPECIAL</b> to 150 kΩ <b>SPECIAL</b> ± 1 % ± 3 %
Linearity (Independent)	± 0.25 % standard	
15 Ω to 1 kΩ 1 kΩ to 5 kΩ 5 kΩ to 25 kΩ 25 kΩ and Above	± 0.15 % ± 0.10 % ± 0.075 % ± 0.05 %	
Noise	100 Ω ENR	
Electrical Rotation	1080° + 4° - 0°	
Power Rating	3.0 W at 40 °C derated to zero at 125 °C	
Insulation Resistance	1000 MΩ minimum 500 V <sub>DC</sub>	
Dielectric Strength	1000 V <sub>RMS</sub> , 60 Hz	
Absolute Minimum Resistance	Not to exceed linearity x total resistance or 1 Ω, whichever is greater	
End Voltage	0.5 % of total applied voltage maximum	
Phasing	CCW end points sect. 2 phased to sect 1 within 1°	
Taps (Extra)	Available as special standard tolerance ± 1°	

<b>ORDERING INFORMATION/DESCRIPTION</b>				
Model 830 can be ordered from this data sheet with a variety of alternate characteristics, as shown. For most rapid service on your order, please state:				
<b>830</b>	<b>B</b>	<b>1</b>	<b>20K</b>	<b>BO10</b>
MODEL	BUSHING MOUNT	NUMBER OF SECTIONS	RESISTANCE OF EACH SECTION	PACKAGING
		From 1 up to 2 sections (maximum)	Beginning with the section nearest the mounting end	Box of 10 pieces

<b>SAP PART NUMBERING GUIDELINES</b>				
<b>830</b>	<b>B</b>	<b>1</b>	<b>203</b>	<b>B10</b>
MODEL	STYLE	NUMBER OF SECTIONS	OHMIC VALUE OF SECTION N° 1	PACKAGING

# Model 830



Vishay Spectrol

1 13/16" (46 mm) Three Turn Wirewound  
Bushing Mount

## DIMENSIONS in inches (millimeters)

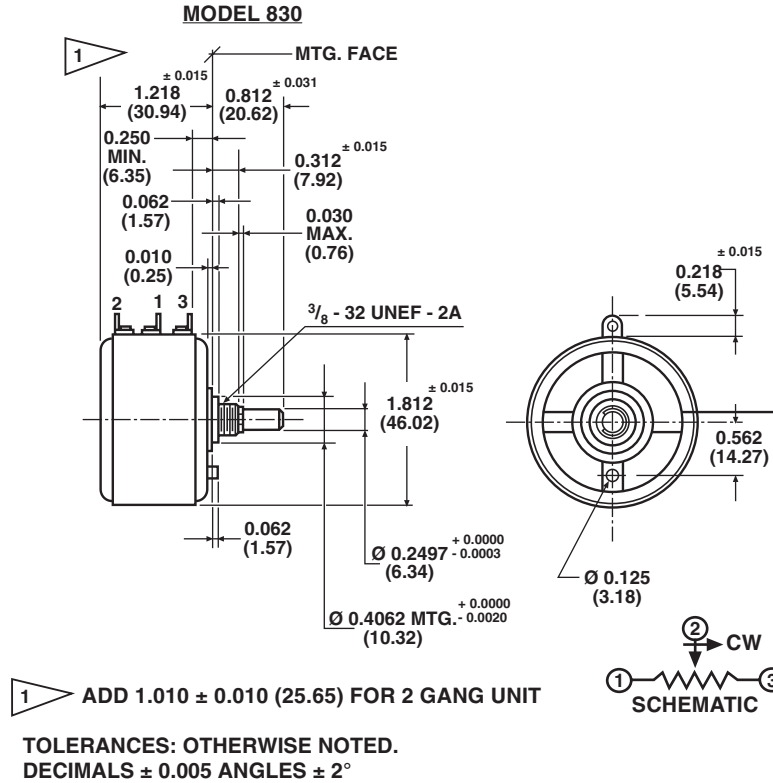

MECHANICAL SPECIFICATIONS		
PARAMETER		
Rotation	1080° + 4° - 0°	
Bearing Type	Sleeve bearing	
Torque (maximums): Starting Section 1 Section 2	<b>STARTING</b> 1.75 oz. - in (126.02 g - cm) 2.55 oz. - in (183.62 g - cm)	<b>RUNNING</b> 1.26 oz. - in (90.01 g - cm) 1.85 oz. - in (133.21 g - cm)
Runouts (Maximums) Shaft (TIR) Pilot Dia. (TIR) Lateral (TIR) Shaft End Play Shaft Radial Play	0.002" (0.05 cm) 0.002" (0.05 cm) 0.005" (0.13 cm) 0.002" min. 0.010" max. (0.05 - 0.25 cm) 0.003" max. (0.08 cm)	
Weight (maximums) Single Section Additional Section	3.0 oz. (85.05 g) 2.5 oz. (70.80 g)	
Stop Strength	750 oz. - in (static) (54.01 kg - cm)	
Ganging	2 sections maximum ears of clamp band between sections positioned 45°, ± 10° CCW from terminal center line	
Moment Inertia	5.5 g - cm <sup>2</sup> maximum	



**1 13/16" (46 mm) Three Turn Wirewound  
Bushing Mount**

Vishay Spectrol

<b>MATERIAL SPECIFICATIONS</b>	
Bushing	Aluminum, nickel plated
Housing and Front Lid	Molded glass filled thermoset plastic
Rear Lid	Molded glass filled nylon
Shaft	Stainless steel, non magnetic, non-passivated
Terminals	Brass, plated for solderability
Mounting Hardware Lockwasher: Panel Nut:	Internal tooth steel, nickel plated Brass, nickel plated

<b>ENVIRONMENTAL SPECIFICATIONS</b>	
Vibration	10 g thru 500 CPS
Shock	50 g
Rotational Life	500 000 shaft revolution
Load Life	900 h
Temperature Range	- 55 °C to + 125 °C
Salt Spray	48 h

<b>MARKING</b>	
<b>Unit Identification</b>	Units will be marked with Spectrol name and model no, resistance and resistance tolerance, linearity, terminal identification, and date code

**POWER RATING CHART**

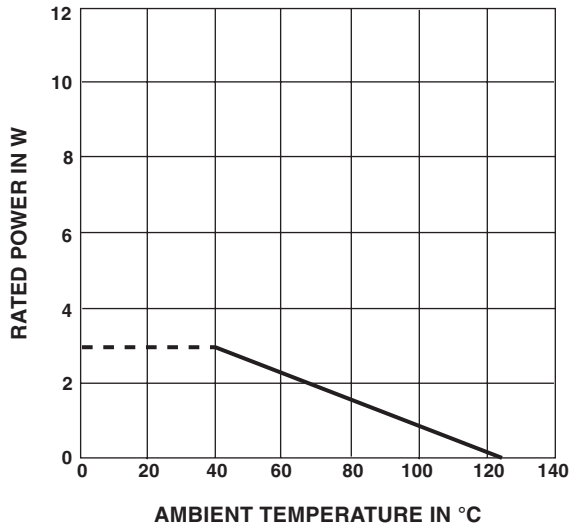

<b>RESISTANCE ELEMENT DATA</b>					
STANDARD RESISTANCE VALUES (W)	RESOLUTION (%)	OHMS PER TURN	MAXIMUM CURRENT AT 70 °C AMBIENT (mA)	MAXIMUM VOLTAGE ACROSS COIL (V)	WIRE TEMP. COEF. (ppm/°C)
20	0.094	0.019	387	8	800
50	0.074	0.037	245	12	800
100	0.071	0.071	173	17	180
200	0.072	0.145	122	25	20
500	0.064	0.320	77	39	20
1K	0.050	0.500	55	55	20
2K	0.047	0.948	39	77	20
5K	0.035	1.73	24	125	20
10K	0.029	2.92	17	176	20
20K	0.024	4.80	12	250	20
50K	0.017	8.31	8	375	20
100K	0.015	14.5	5	600	20
150K	0.013	20.0	4	750	20

## 1 13/16" (46 mm) Three Turn Wirewound Upper Grade Precision Potentiometer

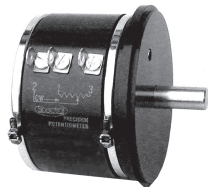

### FEATURES

- Large range of ohmic values: 15  $\Omega$  to 50 k $\Omega$
- Bushing mount, servo mount and screw mount version
- Gangable up to 3 sections
- Extra taps available upon request

ELECTRICAL SPECIFICATIONS		
PARAMETER		
Total Resistance Tolerance: 100 $\Omega$ and Above Below 100 $\Omega$	<b>STANDARD</b> 15 $\Omega$ to 50 k $\Omega$ $\pm 3\%$ $\pm 5\%$	<b>SPECIAL</b> 150 k $\Omega$ $\pm 1\%$ $\pm 3\%$
Linearity (Independent) 15 $\Omega$ to 1 k $\Omega$ 1 k $\Omega$ to 5 k $\Omega$ 5 k $\Omega$ to 25 k $\Omega$ 25 k $\Omega$ and Above	<b>STANDARD</b> $\pm 0.25\%$ $\pm 0.25\%$ $\pm 0.25\%$ $\pm 0.25\%$	<b>SPECIAL</b> $\pm 0.15\%$ $\pm 0.10\%$ $\pm 0.075\%$ $\pm 0.05\%$
Noise	100 $\Omega$ ENR	
Electrical Rotation	1080° + 4° - 0°	
Power Rating Section 1 Additional Sections	2.0 W at 70 °C ambient, derated to zero at 125 °C 75 % of the rating of section 1 (1.5 W at 70 °C)	
Insulation Resistance	1000 M $\Omega$ minimum, 500 V <sub>DC</sub>	
Dielectric Strength	1000 V <sub>RMS</sub> , 60 Hz	
Absolute Minimum, Resistance	Linearity x total resistance or 0.5 $\Omega$ , whichever is greater	
End Voltage	Linearity x total applied voltage for total resistance above 20 $\Omega$ , 2.0 % of total applied voltage for 20 $\Omega$ and below	
Phasing (CCW End Points)	Additional sections phased to section 1 within $\pm 1^\circ$	
Taps (Extra)	Available as special, standard tolerance $\pm 1^\circ$	

ORDERING INFORMATION/DESCRIPTION				
The Model 852 can be ordered from this data sheet with a variety of alternate characteristics, as shown above. For most rapid service on your order, please state:				
<b>852</b>	<b>C</b>	<b>1</b>	<b>50K</b>	<b>BO1</b>
MODEL	MOUNTING	NUMBER OF SECTIONS	RESISTANCE OF EACH SECTION	PACKAGING
	B: Bushing S: Servo C: Screw	From 1 up to 3 max.	Beginning with the section nearest the mounting end	Box of 1 piece

SAP PART NUMBERING GUIDELINES				
<b>852</b>	<b>C</b>	<b>1</b>	<b>503</b>	<b>B01</b>
MODEL	STYLE	NUMBER OF SECTIONS	OHMIC VALUE SECTION N° 1	PACKAGING



**DIMENSIONS** in inches (millimeters)

**SERVO MOUNT**

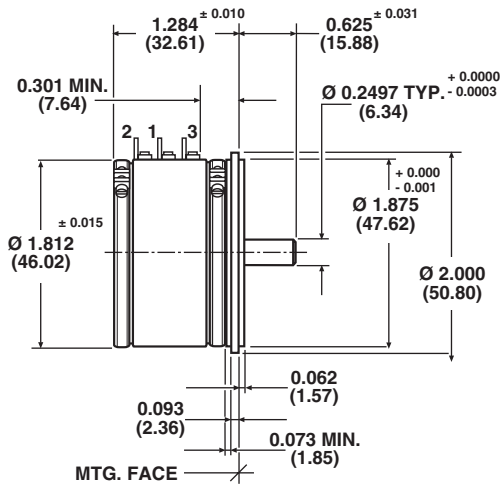

**BUSHING MOUNT**

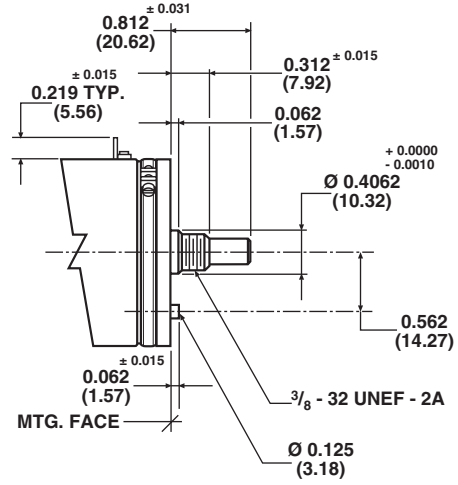

**SCREW MOUNT**

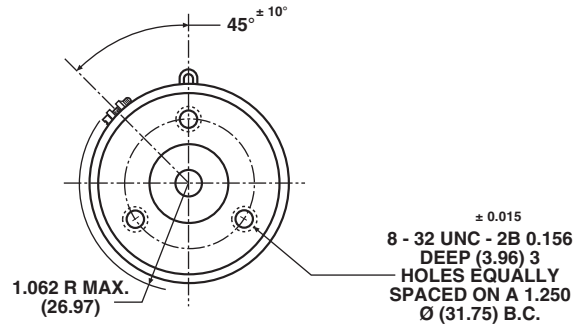
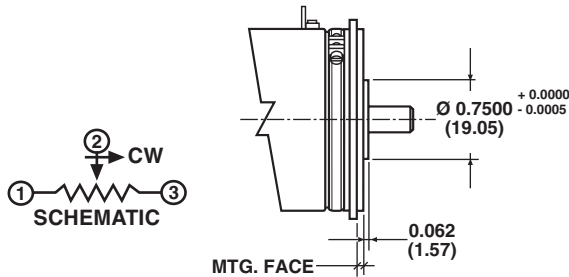

TOLERANCES: UNLESS OTHERWISE NOTED.  
DECIMALS ± 0.005 ANGLES ± 2°

1 ADD 0.992 ± 0.010 (25.20) FOR EACH  
ADDITIONAL SECTION

MECHANICAL SPECIFICATIONS			
PARAMETER			
Rotation	1080° + 10° - 0°		
Bearing Type	<b>SERVO</b> Ball bearing	<b>SCREW</b> Ball bearing	<b>BUSHING</b> Sleeve bearing
Torque (Maximums) Servo or Screw Section 1 Bushing Section 1 Each Additional Section	<b>STARTING</b> 1.20 oz. - in (86.4 g - cm) 1.75 oz. - in (126.0 g - cm) 0.80 oz. - in (57.6 g - cm)		<b>RUNNING</b> 0.80 oz. - in (57.6 g - cm) 1.25 oz. - in (90.0 g - cm) 0.60 oz. - in (43.2 g - cm)
Mechanical Runouts (Maximums): Shaft Runout (TIR/in) Pilot Dia. Runout (TIR) Lateral Runout (TIR) Shaft End Play Shaft Radial Play	<b>SERVO/SCREW</b> 0.002" (0.05 cm) 0.002" (0.05 cm) 0.003" (0.08 cm) 0.005" (0.13 cm) 0.002" (0.05 cm)		<b>BUSHING</b> 0.002" (0.05 cm) 0.002" (0.05 cm) 0.005" (0.13 cm) 0.005" (0.13 cm) 0.003" (0.08 cm)
Weight (Maximums) Single Section Each Additional Section Stop Strength	3.5 oz. (99.2 g) 2.7 oz. (76.5 g) 1000 oz. - in, static (72 kg - cm)		
Ganging	3 sections maximum, terminal alignment, added sections within ± 10° of section 1 terminals		
Moment of Inertia	5.5 g - cm <sup>2</sup> per section maximum		



# Model 852



Vishay Spectrol

1 13/16" (46 mm) Three Turn Wirewound  
Upper Grade Precision Potentiometer

MATERIAL SPECIFICATIONS	
Housing	Glass filled, thermoset plastic
Lids	Aluminum, anodized
Shaft	Stainless steel, non-magnetic non-passivated
Terminals	Brass, plated for solderability
Clamp Ring	Stainless steel
Bushing Mount Hardware Lockwasher Internal Tooth: Panel Nut:	Steel, nickel plated Brass nickel plated

MARKING	
Unit Identification	Units shall be marked with Spectrol name and model No, resistance and resistance tolerance, linearity, terminal identification and date code

ENVIRONMENTAL SPECIFICATIONS	
Vibration	15 g thru 2000 CPS
Shock	50 g
Salt Spray	96 h
Rotational Life	600 000 shaft revolutions
Load Life	900 h
Operating Temperature Range	- 55 °C to + 125 °C

## POWER RATING CHART

(Ratings for cup N° 1.  
Additional cups 75 % of values shown)

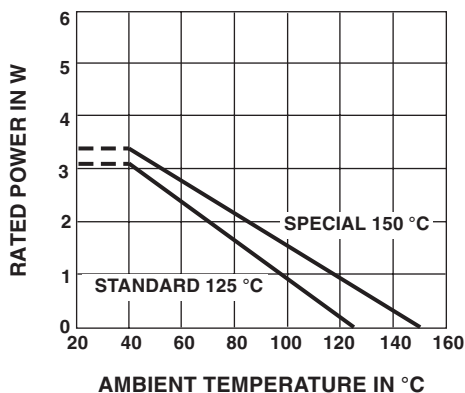

RESISTANCE ELEMENT DATA					
STANDARD RESISTANCE VALUES (Ω)	RESOLUTION (%)	OHMS PER TURN	MAXIMUM CURRENT AT 70 °C AMBIENT (mA)	MAXIMUM VOLTAGE ACROSS COIL (V)	WIRE TEMP. COEF. (ppm/°C)
20	0.094	0.019	316	6.33	800
50	0.074	0.037	200	10.0	800
100	0.071	0.071	141	14.2	180
200	0.072	0.145	100	20.0	20
500	0.064	0.320	63.2	31.6	20
1K	0.050	0.500	44.7	44.7	20
2K	0.047	0.948	31.6	63.3	20
5K	0.035	1.733	20.0	100	20
10K	0.029	2.923	14.1	142	20
20K	0.024	4.797	10.0	200	20
50K	0.017	8.313	6.32	316	20
100K	0.015	14.535	4.47	447	20
150K	0.013	19.987	3.65	548	20

## 1 13/16" (46 mm) Ten Turn Wirewound, Bushing Mount



### FEATURES

- Gangable up to 2 sections
- Large range of ohmic values: 20  $\Omega$  to 200 k $\Omega$
- Extra taps available upon request
- Ideally suits for all industry applications

<b>ELECTRICAL SPECIFICATIONS</b>		
PARAMETER		
Total Resistance Standard Range Tolerance: 200 $\Omega$ and Above Below 200 $\Omega$	20 $\Omega$ to 200 k $\Omega$ <b>STANDARD</b> $\pm 3\%$ $\pm 5\%$	Special up to 500 k $\Omega$ <b>SPECIAL</b> $\pm 1\%$ $\pm 3\%$
Linearity (Independent)	$\pm 0.25\%$ standard	
20 $\Omega$ to 50 $\Omega$ 50 $\Omega$ to 200 $\Omega$ 200 $\Omega$ to 5 k $\Omega$ 5 k $\Omega$ and Above	$\pm 0.15\%$ $\pm 0.10\%$ $\pm 0.05\%$ $\pm 0.025\%$	
Noise	100 $\Omega$ ENR	
Electrical Angle	3600° + 4° - 0°	
Power Rating	8.0 W at 40 °C derated to zero at 125 °C	
Insulation Resistance	1000 M $\Omega$ minimum 500 V <sub>DC</sub>	
Dielectric Strength	1000 V <sub>RMS</sub> , 60 Hz	
Absolute Minimum Resistance	Not to exceed linearity x total resistance or 1 $\Omega$ , whichever is greater	
End Voltage	0.5 % of total applied voltage maximum	
Phasing	CCW end points sect. 2 phased to sect 1 within 1°	
Taps (Extra)	Available as special standard tolerance $\pm 1^\circ$	

<b>ORDERING INFORMATION/DESIGNATION</b>				
Model 860 can be ordered from this data sheet with a variety of alternate characteristics, as shown. For most rapid service on your order, please state:				
<b>860</b>	<b>B</b>	<b>1</b>	<b>20K</b>	<b>BO10</b>
MODEL	BUSHING MOUNT	NUMBER OF SECTIONS	RESISTANCE OF EACH SECTION	PACKAGING
		From 1 up to 2 sections (maximum)	Beginning with the section nearest the mounting end	Box of 10 pieces

<b>SAP PART NUMBERING GUIDELINES</b>				
<b>860</b>	<b>B</b>	<b>1</b>	<b>203</b>	<b>B10</b>
MODEL	STYLE	NUMBER OF SECTIONS	OHMIC VALUE OF SECTION N° 1	PACKAGING

# Model 860

Vishay Spectrol

1 13/16" (46 mm) Ten Turn Wirewound,  
Bushing Mount



**DIMENSIONS** in inches (millimeters)

## MODEL 860

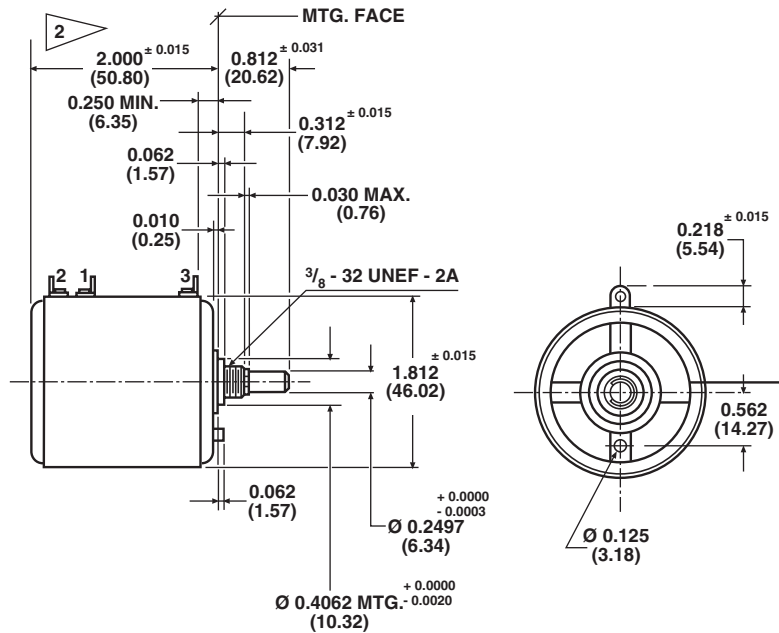

1 ADD 1.787 ± 0.010 (45.39) FOR 2 GANG UNIT

TOLERANCES: OTHERWISE NOTED.  
DECIMALS ± 0.005 ANGLES ± 2°

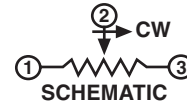

MECHANICAL SPECIFICATIONS		
PARAMETER		
Rotation	3600° + 4° - 0°	
Bearing Type	Sleeve bearing	
Torque (maximums): Section 1 Section 2	<p><b>STARTING</b></p> 1.75 oz. - in (126.02 g - cm) 2.55 oz. - in (183.62 g - cm)	<p><b>RUNNING</b></p> 1.26 oz. - in (90.01 g - cm) 1.85 oz. - in (133.21 g - cm)
Runouts (Maximums) Shaft (TIR) Pilot Dia (TIR) Lateral (TIR) Shaft End Play Shaft Radial Play	0.002" (0.05 cm) 0.002" (0.05 cm) 0.005" (0.13 cm) 0.002" min. 0.010" max. (0.05 - 0.25 cm) 0.003" max. (0.08 cm)	
Weight (maximums) Single Section Additional Section	4.5 oz. (127.58 g) 4.0 oz. (113.40 g)	
Stop Strength	750 oz. - in (static) (54.01 kg - cm)	
Ganging	2 sections maximum ears of clamp band between sections positioned 45°, ± 10° CCW from terminal center line	
Moment Inertia	15.0 g - cm <sup>2</sup> maximum	



**1 13/16" (46 mm) Ten Turn Wirewound,  
Bushing Mount**

Vishay Spectrol

MATERIAL SPECIFICATIONS	
Bushing	Aluminum, nickel plated
Housing and Front Lid	Molded glass filled thermoset plastic
Rear Lid	Molded glass filled nylon
Shaft	Stainless steel, non magnetic, non-passivated
Terminals	Brass, plated for solderability
Mounting Hardware Lockwasher: Panel Nut:	Internal tooth steel, nickel plated Brass, nickel plated

ENVIRONMENTAL SPECIFICATIONS	
Vibration	10 g thru 500 CPS
Shock	50 g
Rotational Life	500 000 shaft revolutions
Load Life	900 h
Temperature Range	- 55 °C to + 125 °C
Salt Spray	48 h

MARKING	
Unit Identification	Units will be marked with Vishay Spectrol name and model no, resistance and resistance tolerance, linearity, terminal identification, and date code

**POWER RATING CHART**

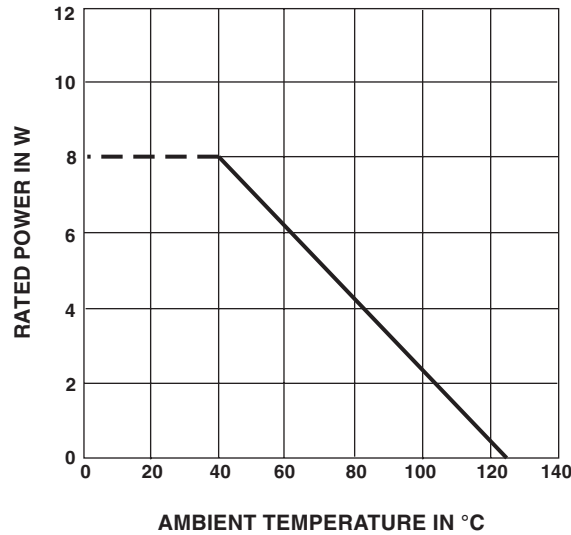

RESISTANCE ELEMENT DATA					
STANDARD RESISTANCE VALUES (Ω)	RESOLUTION (%)	OHMS PER TURN	MAXIMUM CURRENT AT 70 °C AMBIENT (mA)	MAXIMUM VOLTAGE ACROSS COIL (V)	WIRE TEMPERATURE COEFFICIENT (ppm/°C)
20	0.044	0.009	632	13	800
50	0.027	0.014	400	20	800
100	0.024	0.024	283	28	800
200	0.028	0.056	200	40	180
500	0.023	0.115	126	63	20
1K	0.018	0.182	89	89	20
2K	0.020	0.402	63	126	20
5K	0.015	0.754	40	200	20
10K	0.013	1.23	28	283	20
20K	0.010	1.97	20	400	20
50K	0.007	3.69	13	632	20
100K	0.007	6.51	8.9	894	20
200K	0.005	9.63	5.0	1000	20
500K	0.004	20.0	2.0	1000	20





# Special Design

## Contents

Model 601-1045 .....	146
Model 970-1036 .....	148
Model 971 .....	150



## Full 360° Smart Position Sensor

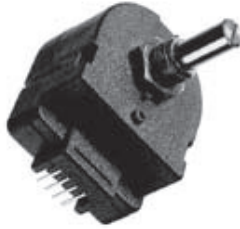

### FEATURES

- Ratiometric output over 360° range with no dead band
- Self-contained package not requiring external electronic interface
- Angular response 50  $\mu$ s
- Reverse polarity protection
- Absolute and non volatile positioning output



The model 601-1045 represents a new generation of Smart Sensors. This unique electronic device is a self-contained package which provides an analog electrical output over a full 360° without the need of external electronics. The low power consumption and non-volatile output makes this universal sensor the real cost-effective alternative to encoders. It's versatile design makes it suitable for a variety of industries and applications, such as CCTVs, Medical Instruments, Robotic arm control, CNC machinery, Rotational control systems, Pick n' place machines and Angular feedback applications.

STANDARD ELECTRICAL SPECIFICATIONS	
PARAMETER	
Supply	4.5 to 5.5 V <sub>DC</sub>
Supply Current	20 mA max.
Absolute Maximum Supply	6 V
Independent Linearity	$\pm 1$ % typical
Resolution	Resolves down to a min. of 0.5°
Electrical Track	360° continuous
Analog Voltage Output	Not less than 90 % of supply (ratiometric) - see graphs on next page
Output Ramp Slope	Electrically switchable - see graphs
Output Impedance	1 $\Omega$ typical
Temperature Characteristic	$\pm 1^\circ$ max. over - 40/+ 70 °C
Insulation Resistance	1000 M $\Omega$ min.
Dielectric Strength	1000 V <sub>RMS</sub> , 50/60 Hz

MECHANICAL SPECIFICATIONS	
Rotation	360° continuous
Rotational Speed	5 max. revs/s (duration 60 s)
Operating Torque Maximum	3.68 (0.5) mNm (oz. - in)
Weight	30 g

ENVIRONMENTAL SPECIFICATIONS	
Operating Life	5 000 000 cycles
Operating Temperature Range	- 40 °C to + 70 °C
Storage Temperature Range	- 40 °C to + 105 °C
Sealing	IP54

ORDERING INFORMATION/DESCRIPTION																		
601-1045 MODEL	XXXX STANDARD CONFIGURATION CODE	BO1 PACKAGING	e4 LEAD FINISH															
	<table border="1"> <thead> <tr> <th>PRODUCT NUMBER</th> <th>Ø 1.57 PIN</th> <th>Ø 3.18 PIN</th> </tr> </thead> <tbody> <tr> <td>0000</td> <td>Yes</td> <td>Yes</td> </tr> <tr> <td>0001</td> <td>Yes</td> <td>-</td> </tr> <tr> <td>0002</td> <td>-</td> <td>Yes</td> </tr> <tr> <td>0003</td> <td>-</td> <td>-</td> </tr> </tbody> </table>	PRODUCT NUMBER	Ø 1.57 PIN	Ø 3.18 PIN	0000	Yes	Yes	0001	Yes	-	0002	-	Yes	0003	-	-		
PRODUCT NUMBER	Ø 1.57 PIN	Ø 3.18 PIN																
0000	Yes	Yes																
0001	Yes	-																
0002	-	Yes																
0003	-	-																

SAP PART NUMBERING GUIDELINES			
601 MODEL	1045 STYLE 1045 or 1056	0001 PIN CONFIGURATION	B01 PACKAGING



**DIMENSIONS** in inches (millimeters)

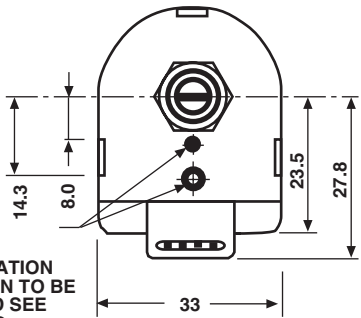

ANTI-ROTATION PIN OPTION TO BE SPECIFIED SEE ORDERING INFORMATION

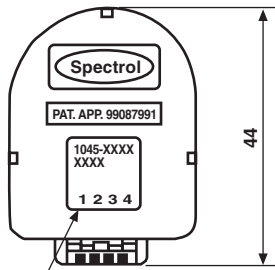
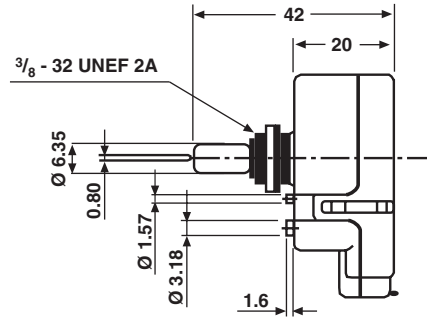

PRODUCT NO. DATE CODE AND TERMINAL I.D. LABEL

PIN CONNECTIONS		FUNCTION
1	+ 5 V	Supply
2	0 V	
3	Output	O/P voltage
4	Direction	Ramp polarity

MATERIAL SPECIFICATIONS	
Housing	Plastic
Bushing	Brass, nickel plated
Shaft	Stainless steel
Pin Terminal Connector	Gold plated
Output Connection	Pin header to suit IDC connectors. e.g. Panduit C100 - F22 and Molex 7880
Bushing Mount Hardware Lock Washer, Internal Tooth	Steel, nickel plated
Panel Nut	Brass, nickel plated



CABLE ASSEMBLY FOR CONNECTION	
Part Number	601-1056-0000
Description	Molex KK
	4-way crimp connector
	4 wire (250 mm)

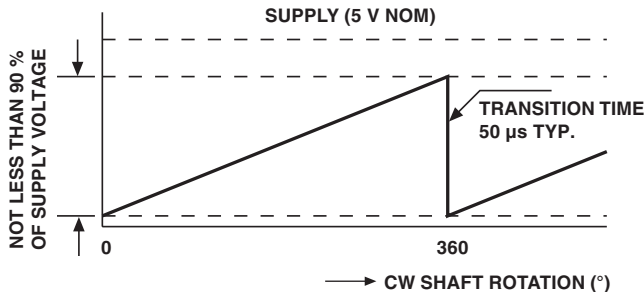

**DEFAULT OUTPUT** [Terminal #4 Open-Circuit]

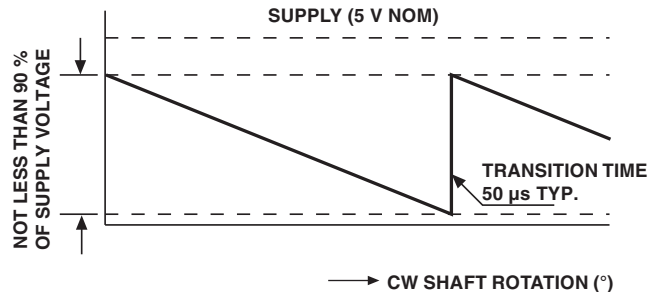

**REVERSE SLOPE** [Terminal #4 Connected to OV]



## Industrial Sensor for Harsh Environment (Throttle Position/Through Hole)



**FEATURES**

- Fully “sealed” robust package
- Electrical connection: AMP superseal 1.5 series integrated connector
- Through hole D drive
- Mountable on both faces
- Reference index indent
- Return spring option
- Standard electrical resistance (and custom options)

The Model 970 has been specifically developed to operate and maintain high functional performance under harsh environmental conditions. These include: extremes of temperature, continuous vibration, chemical exposure and water immersion. This universal device is fully sealed to ingress protection IP67 providing high mechanical durability and long electrical life. This industrial sensor is suitable for a different variety of applications within the automotive, medical and robotic industries.

<b>ELECTRICAL SPECIFICIATONS</b>	
PARAMETER	
Standard Resistance	5 kΩ, ± 20 °C
Resistance Tolerance	± 30 %
Linearity (Absolute)	± 2 %
Electrical Angle	Standard version 200° continuous rotation version 346°
Output Smoothness	0.5 %
Maximum Voltage	30.0 V <sub>DC</sub>
Temperature Coefficient of Resistance	600 ppm/°C

<b>MECHANICAL SPECIFICATIONS</b>	
PARAMETER	
Rotation (Options)	190° with mechanical stops 190 with mechanical stops and return spring 360 continuous
Stop Strength	680 mNm minimum
Fixed Torque (Recommended)	2 to 3 Nm
Spring Torque	Minimum return 20 Nmm Maximum wind-up 115 Nmm
Mounting Pitch	41 mm

<b>ORDERING INFORMATION/DESCRIPTION</b>		
<b>970 - 1036</b> MODEL	<b>0000</b> VERSION	<b>BO100</b> PACKAGING
	0000 Without spring return 0001 With spring return 0002 Continuous rotation	Box of 100 pieces

<b>SAP PART NUMBERING GUIDELINES</b>			
<b>970</b> MODEL	<b>1036</b> STYLE	<b>0000</b> CONFIGURATION	<b>B30</b> PACKAGING



**DIMENSIONS** in inches (millimeters)

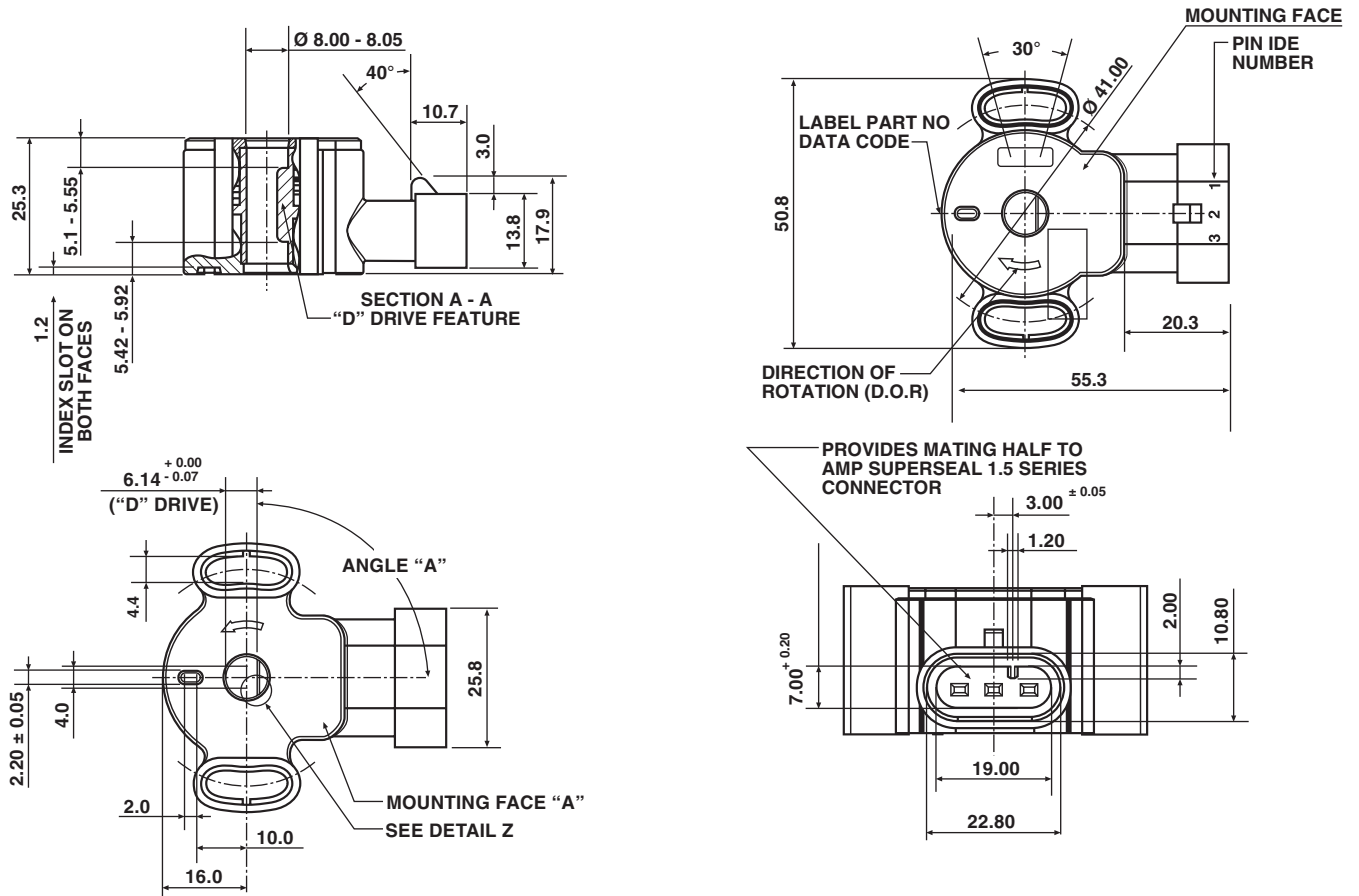

ENVIRONMENTAL SPECIFICATIONS	
PARAMETER	
Vibration	15 g thru 2000 Hz
Shock	50 g
Rotational Life	5 000 000 full cycles 10 000 000 dither cycles (second rotation)
Load Life	900 h
Temperature Range	- 40 °C to + 130 °C
Sealing	IP67
Humidity	96 % at 40 °C (500 h)
Salt Spray	5 % solution at 40 °C (300 h)

MARKING	
Unit Identification	Manufacturer's name and model number, resistance value, tolerance, data code and terminal identification

## Throttle Position Sensor with Integrated Spring Return System



### FEATURES

- High performance, compact potentiometric sensor
- Rugged construction, suitable for under-bonnet engine management and closed loop feedback applications
- Through-hole actuation capability
- Integral connector or flying lead versions
- Actuator and mounting configuration options

Spectrol Model 971 series Rotary Position Sensors are suitable for demanding environments where high life and consistent linearity performance is required. Typical applications include Electrical Industrial Vehicles, Off-Road Vehicle Steering and Transmission, Automotive Engine Management Systems and Controls.

The 971 Rotational Position Sensor can be supplied with options for electrical track length, resistance, flying leads, integral connector and actuator drive direction

<b>ELECTRICAL SPECIFICATIONS</b>	
PARAMETER	
Total Resistance Optional	5 kΩ at + 25 °C 1 kΩ to 25 kΩ
Resistance Tolerance	± 20 %
Linearity (Independent)	± 2 %
Electrical Travel	106° optional to 130° max.
Maximum Power Rating	1 W at 40 °C derated to zero at 135 °C
Output Smoothness	0.3 % max.
Temperature Coefficient	± 600 ppm/°C
Index Point (e/E)	3 % ± 2 %
Maximum Voltage	13.5 V <sub>DC</sub>

<b>MECHANICAL SPECIFICATIONS</b>	
PARAMETER	
Rotation Optional	130° ± 5° CCW CCW or CW up to 140° max. ± 5 %
Spring Torque	120 mNm max.
Stop Strength	680 mNm min.
End Play	0.25 mm max.
Lead Wires	Nominal Ø 1.8 mm length optional
Wire Pull Strength	10 kg max. (3 wires)

<b>ORDERING INFORMATION/DESCRIPTION</b>		
971 MODEL	0001 OUTPUT TYPE 0001: Amp connector 0002: Flying leads	B0100 PACKAGING Box of 100 pieces

<b>SAP PART NUMBERING GUIDELINES</b>		
971 MODEL	0001 STYLE	B30 PACKAGING



**Throttle Position Sensor with  
Integrated Spring Return System**

**DIMENSIONS** in inches (millimeters)

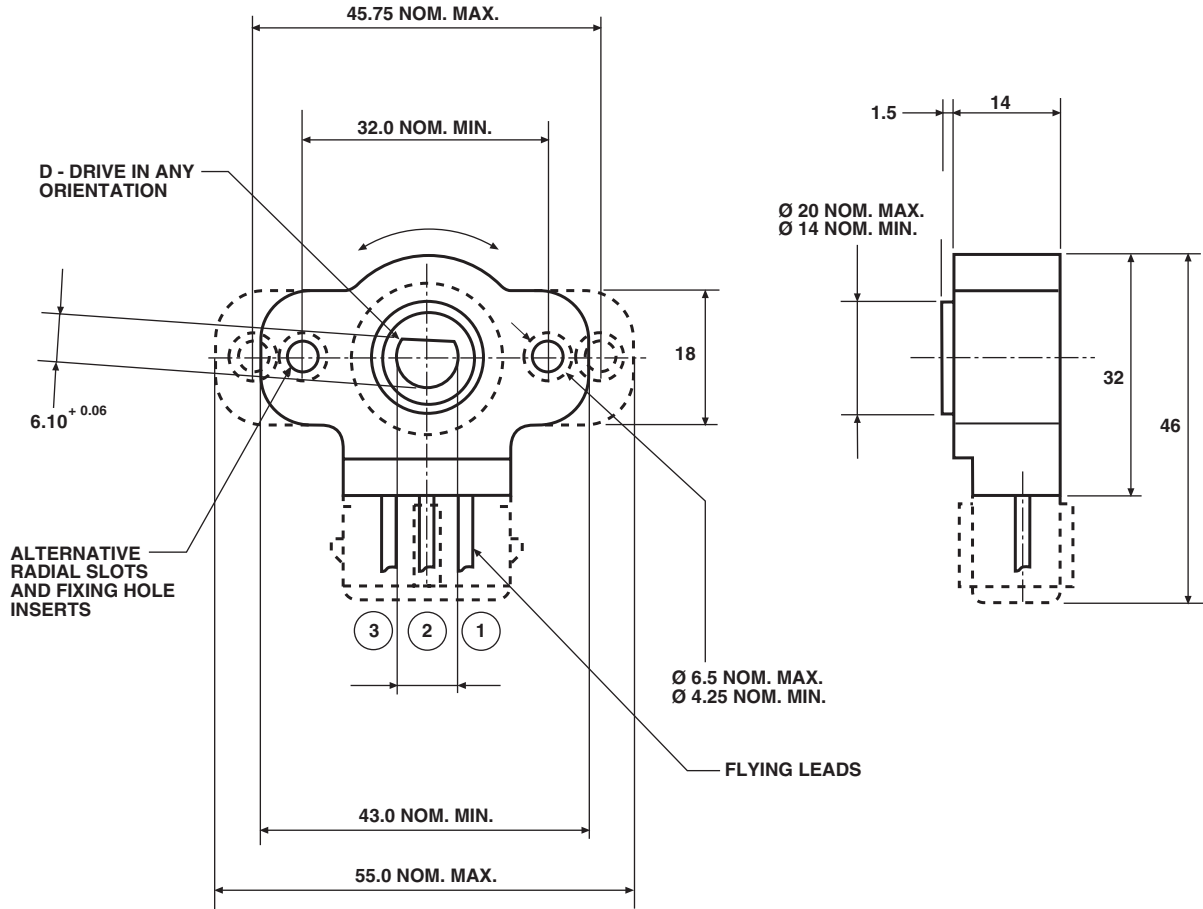

ENVIRONMENTAL SPECIFICATIONS	
Rotational Life	5 x 10 <sup>6</sup> full cycles
Dither	10 x 10 <sup>6</sup> (2° rotation)
Vibration	15 g, 50 to 1000 Hz
Shock	50 g
Temperature Range: Standard Operating Optional Operating	- 40 °C to + 85 °C - 40 °C to + 130 °C
Materials: Housing	Polyester PBT
Leads: Standard PVC High Temperature PVC	+ 85 °C + 130 °C

OPTIONAL INTEGRAL CONNECTOR	
AMP style Junior Timer Mates: Housing Terminals	1 - 8275782 - 1 (unsealed) 927845 - 2
Housing Terminals Wire Seals	282191 - 1 (sealed) 929939 - 3 828904 - 1





## Contents

Model 120E ..... 154

Model DE2 ..... 156

# Other Technologies Encoders

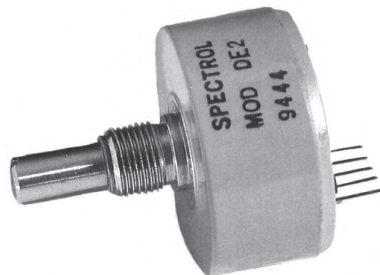
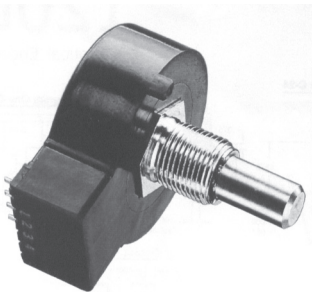

## Incremental Optical Encoder Contactless Technology (128 Pulses per Turn)

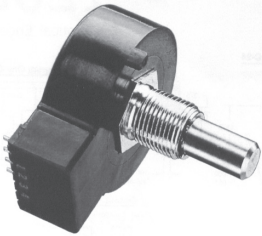

### FEATURES

- Long life: 10 million revolutions minimum (contactless)
- Cost effective: Elimination of A/D converters
- Stainless steel shafts and nickel-plated bushing in various lengths
- Stability: - 40 °C to + 65 °C operating temperature
- Variability: Cable and printed circuit terminations available



The Model 120E is a light-duty optical encoder that can be manually. This unique device outputs two square waves at a maximum rate of 128 pulses in quadrature with other resolutions as low as 10 pulses available. Typical applications includes Motion sensing and control, Motor control, Flow control, Low-to-high input for test and measurement, Medical instrumentation, Robotics and Computer Peripherals.

ELECTRICAL SPECIFICATIONS			
PARAMETER	MINIMUM	NOMINAL	MAXIMUM
VCC Range (V)	4.75	5	5.25
Supply Current (mA)	-	-	30
Voh (V)	2.4	-	-
Vol (V)	-	-	0.4
Pull-up Resistor (kΩ)	-	10	-
Output	Channel A leads channel B by 90° electrically, CCW direction		

MECHANICAL SPECIFICATIONS	
PARAMETER	
Vibration	10 to 2000 Hz, 15 G mil std., - 202 method 204 test condition C
Shock	100 G at 6 ms mil std. 202, method 213 test condition C
Rotational Torque	Sleeve Bearing 1.5 oz. in <b>Other torque ranges available</b>
Operating Speed	300 RPM
Rotational Life	10 000 000 revolutions
Shaft End Play	0.005 maximum
Shaft Radial Play	0.010 at 1"
Shaft Axial Force	15 lbs. push/pull
Terminal Strength	2 lbs.

ORDERING INFORMATION/DESCRIPTION						
120	E	N	128	CBL	BO100	e4
MODEL	PRODUCT ID	SHAFT AND BUSHING SIZE	PULSES PER RESOLUTION	TERMINATION	PACKAGING	LEAD FINISH
Sleeve-bearing construction with two channel quadrature output	<b>E</b> = Encoder	<b>N</b> = 1/4" (6.35 mm) diameter by 0.875" (22.23 mm) long shaft 3/8" (9.53 mm) diameter x 32 NEF 2A by 3/8" (9.53 mm) long bushing	Number of pulses per revolution	<b>B66</b> = PC terminal type B-66 horizontal mounting <b>C24</b> = PC terminal type C-24, vertical mounting <b>CBL</b> = 7.5" (190.5 mm) long cable <b>CN1</b> = Cable with connector	Box of 100 pieces	

SAP PART NUMBERING GUIDELINES			
120EN	128	CBL	B30
MODEL	PULSES PER REVOLUTION	TERMINAL CONFIGURATION	PACKAGING



**DIMENSIONS** in inches (millimeters)

**120E SERIES**

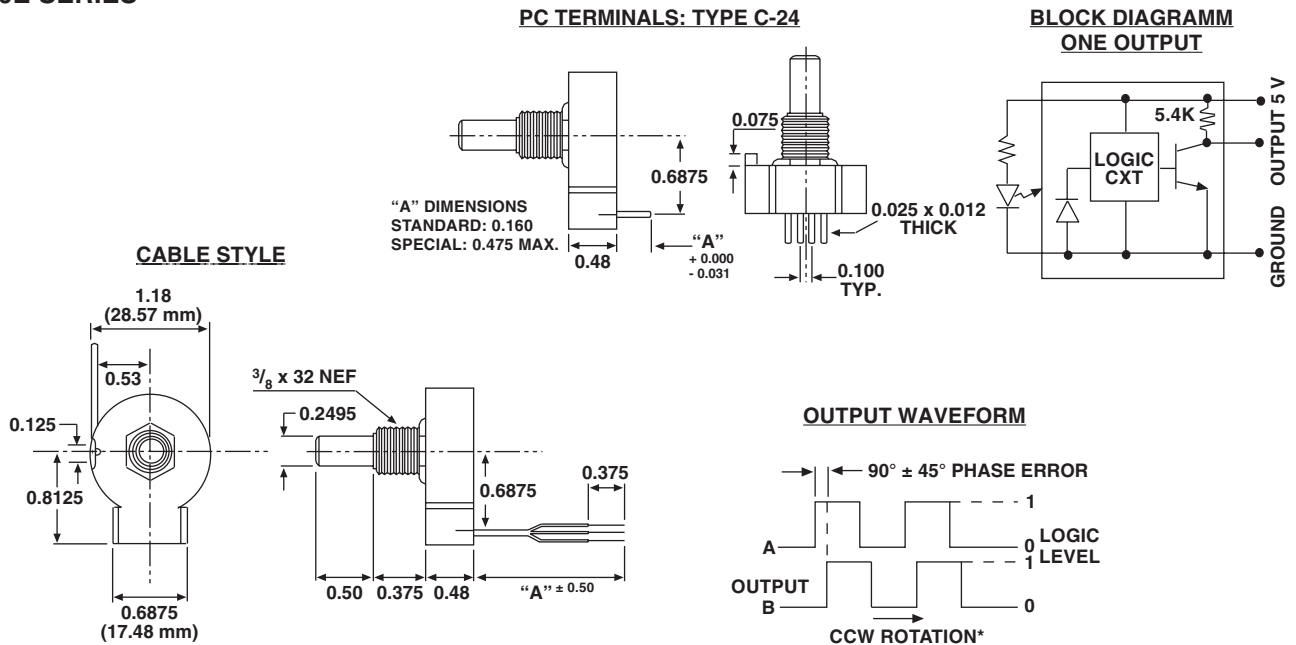

\*Channel A leads channel B by 90° electrically in CCW direction

**PC TERMINALS: TYPE B-66**

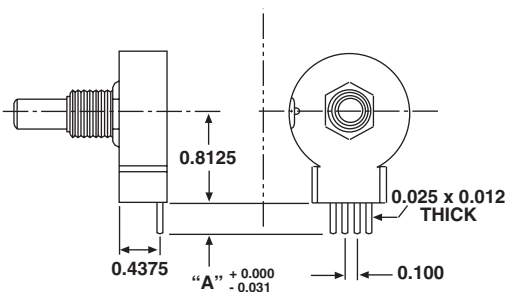

TERM #	FUNCTION
1	5 V <sub>DC</sub> ± 5 % at 30 ma max.
2	"A" out
3	Ground
4	"B" out

"A" DIMENSIONS	
Standard	0.160
Special	0.400 max.

**Dimension Tolerances, Unless Otherwise Specified**

FRACTIONS = ± 1/64 (0.40 mm)    DECIMALS = ± 0.005    GRDS = ± 0.010 (0.25 mm)

**Notes:**

- (1) "A" cable length standard 7.50 ± 0.50. Other lengths available, specified by customer.
- (2) "A" and "B" outputs are TTL compatible on all models.

COLOR	FUNCTION
Red	5V <sub>DC</sub> ± 5 % at 30 ma max.
Green	Ground
Yellow	"A" out
Orange	"B" out

ENVIRONMENTAL SPECIFICATIONS			
PARAMETER	MINIMUM	NOMINAL	MAXIMUM
Operating Temperature (°C)	- 40 °C	-	+ 65 °C
Storage Temperature (°C)	- 55 °C	-	+ 110 °C
Humidity	85 % RH at 40 °C, 240 h	-	-

TERMINAL	
Terminal	B66: PC Terminals, horizontal mounting C24: PC Terminals, vertical mounting CBL: 7.5 including cable CN1: 7.5 including cable with connector



## Incremental Resistive Encoder (32 to 128 Pulses per Turn)

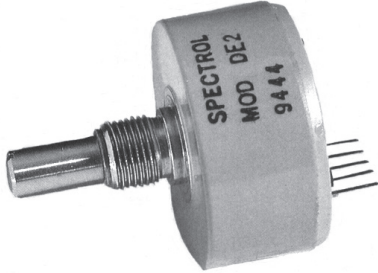

### FEATURES

- Patented Silver-in-Glass™ switching element technology
- Two channel quadrature output
- Optional index pulse
- 32 pulses per revolution (can be resolved to 128 increments per revolution)
- Additional pulses per revolution available (consult factory)
- Internal active debounce circuitry provides clean, high level outputs with CMOS or TTL logic
- Optional shaft seal

<b>ELECTRICAL SPECIFICATIONS (CMOS) FOR STD. DE2</b>				
PARAMETER	SYMBOL	MIN.	MAX.	UNITS
Input Specifications				
Supply Voltage	V <sub>S</sub>	3.0	6.0	V
Supply Current	I <sub>S</sub>	-	4.0	mA
Output Specifications				
Output High Voltage (V <sub>S</sub> = 5.0 V, I <sub>O</sub> = 4.0 mA)	V <sub>OH</sub>	3.8	-	V
	-	-	-	-
Output Low Voltage (I <sub>O</sub> = 4.0 mA)	V <sub>OL</sub>	-	0.4	V
	-	-	-	-
Output Current	I <sub>O</sub>	-	20	mA

<b>MECHANICAL SPECIFICATIONS</b>		
PARAMETER		
Rotational Speed	<b>CONTINUOUS</b> 200 RPM	<b>PERIODIC</b> 400 RPM
Operating Torque	<b>STARTING</b> 1.0 oz. - in max.	<b>RUNNING</b> 0.7 oz. - in
Bearing	Sleeve	
Shaft Runouts (TIR)	0.002"	
Pilot Runouts (TIR)	0.003"	
Lateral Runouts (TIR)	0.005"	
End Play	0.008"	
Radial Play	0.003"	
Weight	1 oz. max.	

<b>ORDERING INFORMATION/DESCRIPTION</b>				
DE2	0	1	32	BO10
MODEL			OPTIONS AVAILABLE	PACKAGING
	0 - Standard 1 - Index <sup>(1)</sup>	0 - No debounce 1 - CMOS debounce circuitry 2 - TTL debounce circuitry		

**Note:**

(1) Index option requires debounce circuitry

<b>SAP PART NUMBERING GUIDELINES</b>				
DE2	0	1	128	B10
MODEL	STYLE	CONFIGURATION	PULSES PER REVOLUTION	



# Incremental Resistive Encoder (32 to 128 Pulses per Turn)

**Model DE2**  
Vishay Spectrol

**DIMENSIONS** in inches (millimeters)

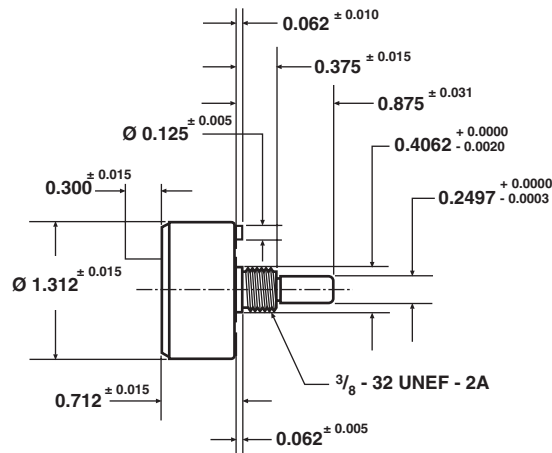

**TERMINAL CONFIGURATION**

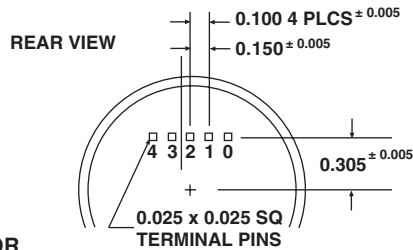

MATING CONNECTOR  
AMP - MODU CONNECTOR FAMILY  
MOLEX 70066 FAMILY

**TIMING DIAGRAM**

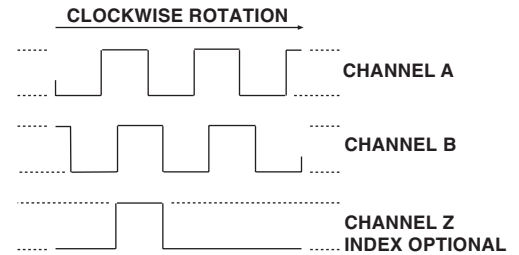

STANDARD (DE2-0-X-32)	
TERMINAL	FUNCTION
1	Input ( $V_s$ )
2	Common
3	Channel A out
4	Channel B out

INDEX (DE2-1-X-32)	
TERMINAL	FUNCTION
0	Input ( $V_s$ )
1	Common
2	Channel A out
3	Channel Z out
4	Channel B out

MATERIAL SPECIFICATIONS	
Housing	Molded, glass filled thermoplastic
Shaft	Stainless steel
Bushing	Brass, nickel plated
Terminal Pins	Phosphor bronze, solderable
Mounting Hardware: Lockwasher Panel Nut	Steel, nickel plated Brass, nickel plated

ENVIRONMENTAL SPECIFICATIONS	
PARAMETER	
Rotational Life	5 million shaft revolutions
Temperature Range: Operating Storage	- 20 °C to + 85 °C - 55 °C to + 125 °C
Vibration	15 G, at 0 to 2 kHz
Shock	50 G
Moisture Resistance	Method 106, MIL-STD-202
Salt Spray	48 h





# Other Technologies

## Hall Effect Sensors

### Contents

Model 351 HE .....	160
Model 601 HE .....	164
Model 631 HE .....	166

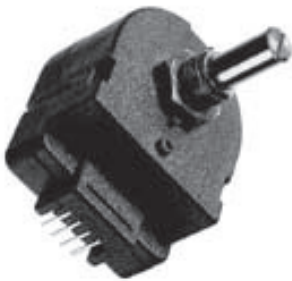

## Single Turn Bushing Mount Hall Effect Sensor in Size 09 (22.2 mm)



### FEATURES

- Accurate linearity down to:  $\pm 0.5\%$
- All electrical angles available up to:  $360^\circ$  (no dead band)
- Long life: greater than 10M cycles
- Non contacting technology: Hall effect
- Model dedicated to all applications in harsh environments



ELECTRICAL SPECIFICATIONS		
PARAMETER	STANDARD	SPECIAL
Electrical Angle	90°, 180°, 270°, 360°	Any other angle upon request
Linearity	$\pm 1\%$	$\pm 0.5\%$
Supply Voltage	5 V <sub>DC</sub> $\pm 10\%$	Other upon request
Supply Current	10 mA typical	16 mA for PWM output
Output Signal	Analog ratiometric 10 % to 90 % of V <sub>supply</sub> or PWM 10 % to 90 % duty cycle	Other upon request
Over Voltage Protection		+ 20 V <sub>DC</sub>
Reverse Voltage Protection		- 10 V <sub>DC</sub>
Load Resistance Recommended	Min. 1 k $\Omega$ for analog output and PWM output	
Hysteresis	< 0.2 %	

MECHANICAL SPECIFICATIONS	
PARAMETER	
Mechanical travel	360° continuous, stops upon request: $340^\circ \pm 3^\circ$
Bearing type	Sleeve bearing
Standard	IP 50; other on request
Weight	20 g $\pm 2$ g

ORDERING INFORMATION/DESCRIPTION									
351HE	0	A	1	W	A	1S22	XXXX	BO 10	e1
MODEL	FEATURES	LINEARITY	ELECTRICAL ANGLE	OUTPUT TYPE	OUTPUT SIGNAL	SHAFT TYPE	SPECIAL REQUEST	PACKAGING	LEAD FINISH
0:	Continuous rotation and antirotation pin	A: $\pm 1\%$ B: $\pm 0.5\%$	1: 90° 2: 180° 3: 270° 4: 360° 9: Other angles	W: Wires Z: Custom	A: Analog CW B: Analog CCW C: PWM CW D: PWM CCW Z: Other output	0: 6 mm 1: 6.35 mm 2: 3.175 mm 9: Special P: Plain S: Slotted Z: Other type		Box of 10 pieces	
1:	Continuous rotation and no antirotation pin								
2:	Stops at 340° and antirotation pin								
3:	Stops at 340° and no antirotation pin								
Shaft length from mounting face 22 mm to 72 mm max. per step of 5 mm									

SAP PART NUMBERING GUIDELINES							
351HE	1	B	9	Z	C	0P27	XXXX
MODEL	MECHANICAL FEATURES	LINEARITY	ELECTRICAL ANGLE	OUTPUT TYPE	OUTPUT SIGNAL	SHAFT TYPE	SPECIAL REQUEST



**V<sub>OUT</sub> ANALOG**

Operating Temperature	85 °C	125 °C
Diagnostic High Level	96 % min.	96 % min.
Diagnostic Low Level	2 % max.	4 % max.

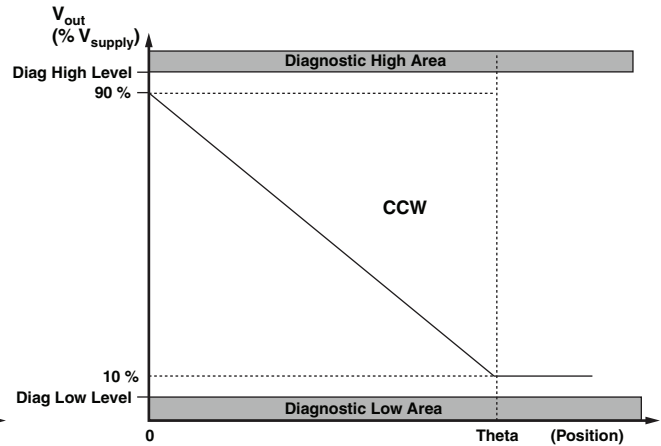
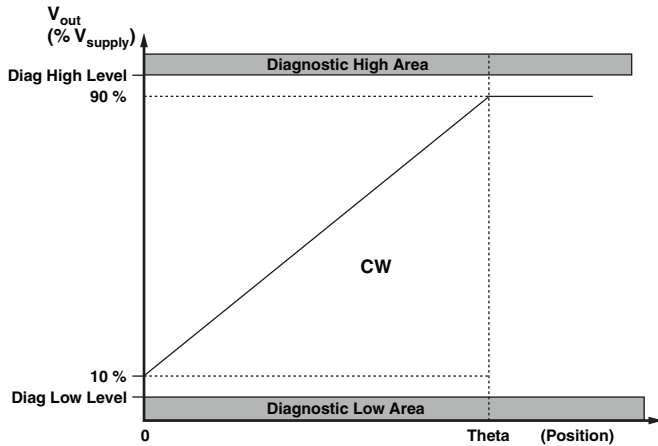

**V<sub>OUT</sub> PWM**

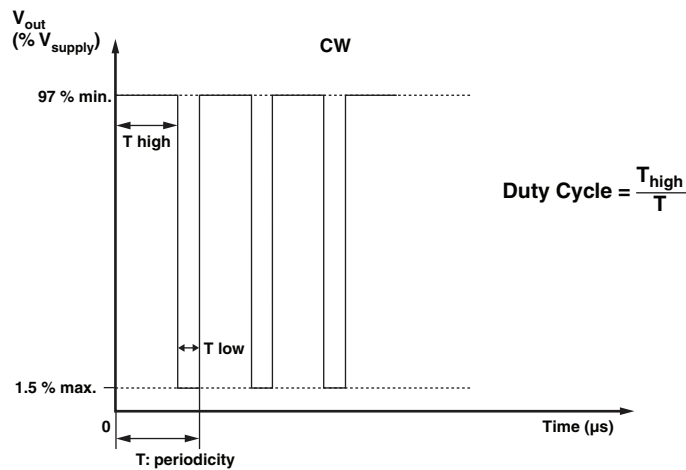

DIAGNOSTIC MODES			
FAILURE	$V_{out}$ Analog $R_{pull-up}$	$V_{out}$ Analog $R_{pull-down}$	$V_{out}$ PWM $R_{pull-up} = 1\text{ k}\Omega$ $V_{pull-up} = V_{supply} = 5\text{ V}$
1: Broken GND	Diagnostic high area	Diagnostic low area	> 97 % $V_{supply}$ without modulation
2: Broken $V_{out}$	Diagnostic high area	Diagnostic low area	> 97 % $V_{supply}$ without modulation
3: Broken $V_{supply}$	Diagnostic high area	Diagnostic low area	> 97 % $V_{supply}$ without modulation
Over Voltage $V_{supply} > 7\text{ V}$	Diagnostic high area	Diagnostic low area	> 97 % $V_{supply}$ without modulation
Under Voltage $V_{supply} < 2.7\text{ V}$	Diagnostic high area	Diagnostic low area	> 97 % $V_{supply}$ without modulation

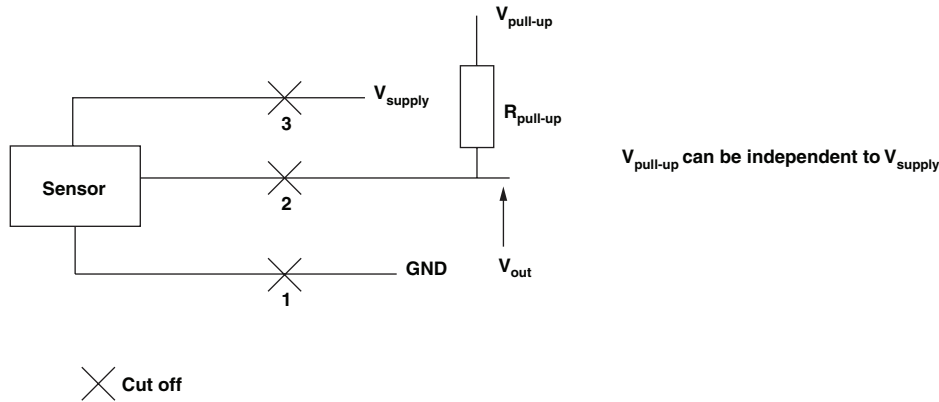

ENVIRONMENTAL SPECIFICATIONS	
Vibrations	20 G from 10 Hz to 2000 Hz
Shocks	3 shocks/axis; 50 G half a sine 11 ms
Operating Temperature Range	- 45 °C; + 125 °C
Life	> 10M of cycles
Rotational Speed (max)	120 rpm
Immunity to Radiated Electromagnetic Disturbances	200 V/m 150 kHz/1 GHz
Immunity to Power Frequency Magnetic Field	200 A/m 50 Hz/60 Hz
Radiated Electromagnetic Emissions	30 MHz/1 GHz < 30 dB $\mu$ V/m
Electrostatic Discharges	Contact discharges: $\pm 4\text{ kV}$ Air discharges: $\pm 8\text{ kV}$
<b>Materials</b>	
Housing	Thermoplastic housing
Bushing	Brass nickel plated
Shaft	Stainless steel
Output	3 lead wires
<b>Bushing Mount Hardware</b>	
Lockwasher Internal Tooth	Steel nickel plated
Panel Nut	Brass nickel plated



**DIMENSIONS** in millimeters

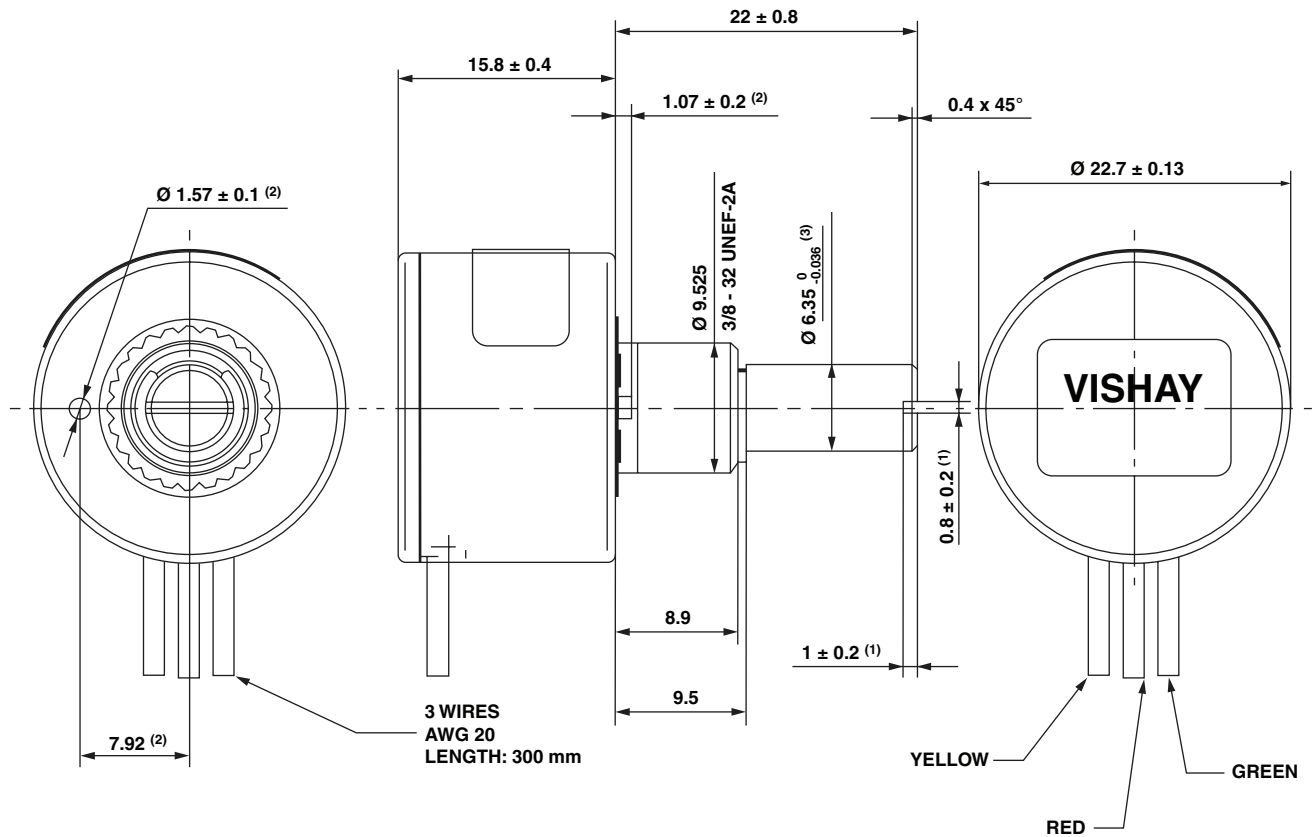

GENERAL TOLERANCE:  $\pm 0.5$  mm

CW OR CCW ACCORDING  
OUTPUT MODE CHOICE

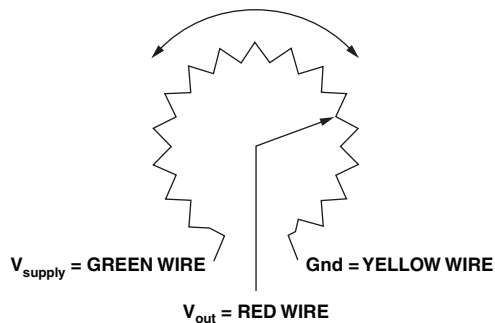

VIEWED FROM SHAFT

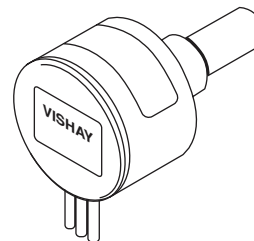

**Notes:**

- (1) For version slotted shaft
- (2) For version non turn pin
- (3) For shaft type "1"

MARKING	
Unit Identification	Manufacturer's name and complete sap part reference, date code, and wiring correspondance: colors versus connections.



## Full 360° Smart Sensor (Hall Effect Technology)

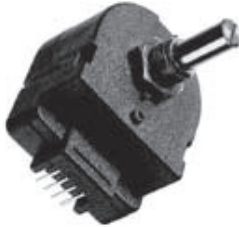

### FEATURES

- Absolute ratiometric output over 360° range with no dead band
- Self-contained package not requiring external electronic interface
- Contactless technology
- Reverse polarity protection
- Non volatile positioning output



The model 601-HE represents a new generation of Smart Sensors in contactless technology based on the Hall effect principle. This unique electronic device is a self-contained package which provides an analog electrical output over a full 360° without the need of external electronics. The low power consumption and non-volatile output makes this universal sensor the real cost-effective alternative to encoders.

STANDARD ELECTRICAL SPECIFICATIONS	
PARAMETER	
Supply	4.5 to 5.5 V <sub>DC</sub>
Supply Current	10 mA maximum
Over Voltage Protection	10 V
Independent Linearity	± 1 %; ± 0.5 %
Electrical Track	360° continuous
Analog Voltage Output	Not less than 90 % of supply (ratiometric) CW or CCW see graphs on next page
Output Ramp Slope	Electrically switchable - see graphs
Temperature Coefficient	60 μV/°C
Hysteresis	< 0.2 %

MECHANICAL SPECIFICATIONS	
Rotation	360° continuous
Rotational Speed (Max.)	120 RPM
Operating Torque Max.	0.25 oz. - in (18 g - cm)
Weight	30 g

ENVIRONMENTAL SPECIFICATIONS	
Operating Life	5 000 000 Cycles
Operating Temperature Range	- 45 °C + 125 °C
Storage Temperature Range	- 45 °C to + 125 °C
Sealing	IP54

ORDERING INFORMATION/DESCRIPTION						
MODEL	OUTPUT SIGNAL DIRECTION	CONFIGURATION CODE		LINEARITY	PACKAGING	LEAD FINISH
601 HE	1	000		A	BO1	e4
	1: CW 2: CCW	<b>PRODUCT NUMBER</b>	<b>Ø 1.57 PIN</b>	<b>Ø 3.18 PIN</b>	Box of 1 piece	
		000	Yes	Yes		
		001	Yes	-		
		002	-	Yes		
		003	-	-		
				A: ± 1 % B: ± 0.5 %		

SAP PART NUMBERING GUIDELINES				
MODEL	OUTPUT SIGNAL	PIN CONFIGURATION	LINEARITY	PACKAGING
601 HE	2	001	B	B01
	2: CCW		B: ± 0.5 %	



**DIMENSIONS** in millimeters

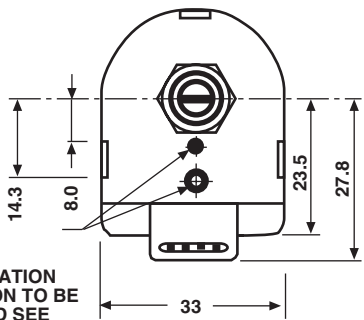

ANTI-ROTATION  
PIN OPTION TO BE  
SPECIFIED SEE  
ORDERING  
INFORMATION

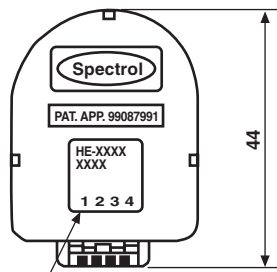

PRODUCT NO. DATE  
CODE AND TERMINAL  
I.D. LABEL

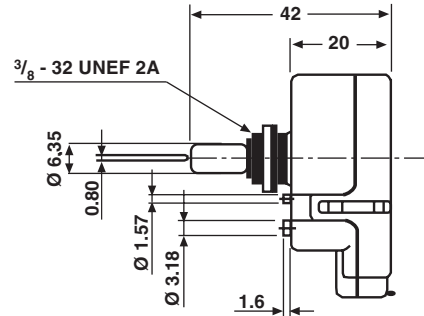

PIN CONNECTIONS		FUNCTION
1	+ 5 V	Supply
2	0 V	
3	Output	O/P voltage
4	Direction	Ramp polarity

MATERIAL SPECIFICATIONS	
Housing	Plastic
Bushing	Brass, nickel plated
Shaft	Stainless steel
Pin terminal connector	Gold plated
Output connection	Pin header to suit IDC connectors. e.g. Panduit C100 - F22 and Molex 7880
Bushing Mount Hardware Lock Washer, Internal Tooth	Steel, nickel plated
Panel Nut	Brass, nickel plated



CABLE ASSEMBLY FOR CONNECTION	
Part Number	601-1056-0000
Description	Molex KK
	4-way crimp connector
	4 wire (250 mm)

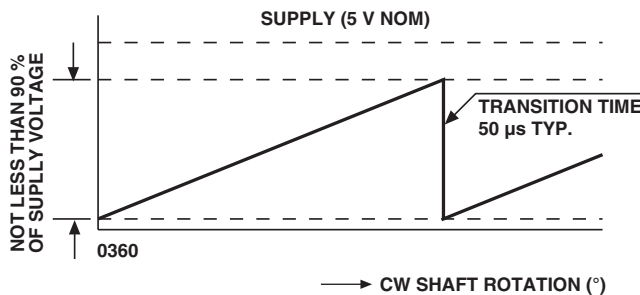

MODEL: 601 HE 1xxx

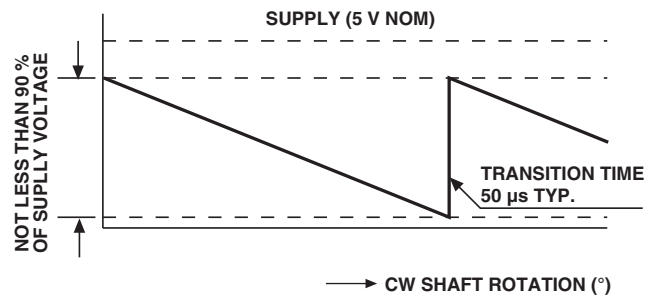

MODEL: 601 HE 2xxx

## Single Turn Bushing Mount Hall Effect Sensor in Size 09 (22.2 mm)



### FEATURES

- Accurate linearity down to:  $\pm 0.5\%$
- All electrical angles available up to:  $360^\circ$  (no dead band)
- Long life: over 20M cycles
- Non contacting technology: Hall effect
- Model dedicated to all applications in harsh environments
- Robust tool machined aluminum housing



ELECTRICAL SPECIFICATIONS		
PARAMETER	STANDARD	SPECIAL
Electrical Angle	90°, 180°, 270°, 360°	Any other angle upon request
Linearity	$\pm 1\%$	$\pm 0.5\%$
Supply Voltage	5 V <sub>DC</sub> $\pm 10\%$	Other upon request
Supply Current	10 mA typical	16 mA for PWM output
Output Signal	Analog ratiometric 10 % to 90 % of V <sub>supply</sub> or PWM 10 % to 90 % duty cycle	Other upon request
Over Voltage Protection	+ 20 V <sub>DC</sub>	
Reverse Voltage Protection	- 10 V <sub>DC</sub>	
Load Resistance Recommended	Min. 1 k $\Omega$ for analog output and PWM output	
Hysteresis	< 0.2 %	

MECHANICAL SPECIFICATIONS		
PARAMETER		
Mechanical Travel	360° continuous	
Bearing Type	Sleeve bearing	Ball bearing upon request
Standard	IP 50; other on request	
Weight	20 g $\pm 2$ g	

ORDERING INFORMATION/DESCRIPTION									
631HE	0	A	1	W	A	1S22	XXXX	BO 10	e1
MODEL	FEATURES	LINEARITY	ELECTRICAL ANGLE	OUTPUT TYPE	OUTPUT SIGNAL	SHAFT TYPE	SPECIAL REQUEST	PACKAGING	LEAD FINISH
	0: Continuous rotation and antirotation pin 1: Continuous rotation and no antirotation pin	A: $\pm 1\%$ B: $\pm 0.5\%$	1: 90° 2: 180° 3: 270° 4: 360° 9: Other angles	W: Wires Z: Custom	A: Analog CW B: Analog CCW C: PWM CW D: PWM CCW Z: Other output	0: 6 mm 1: 6.35 mm 2: 3.175 mm 9: Special P: Plain S: Slotted Z: Other type		Box of 10 pieces	
Shaft length from mounting face 22 mm to 72 mm max. per step of 5 mm									

SAP PART NUMBERING GUIDELINES							
631HE	1	B	9	Z	C	0P27	XXXX
MODEL	MECHANICAL FEATURES	LINEARITY	ELECTRICAL ANGLE	OUTPUT TYPE	OUTPUT SIGNAL	SHAFT TYPE	SPECIAL REQUEST



**V<sub>OUT</sub> ANALOG**

Operating Temperature	85 °C	125 °C
Diagnostic High Level	96 % min.	96 % min.
Diagnostic Low Level	2 % max.	4 % max.

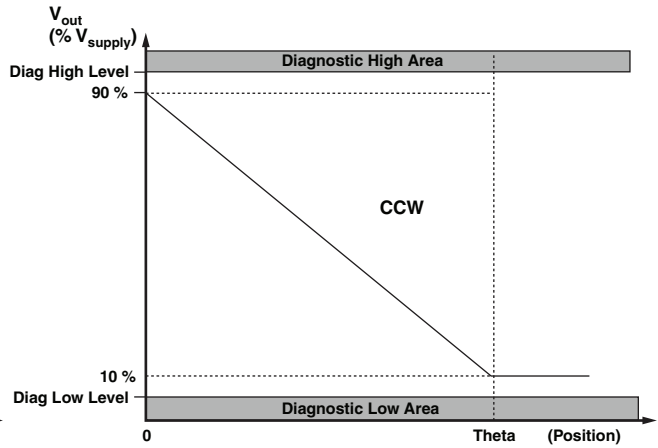
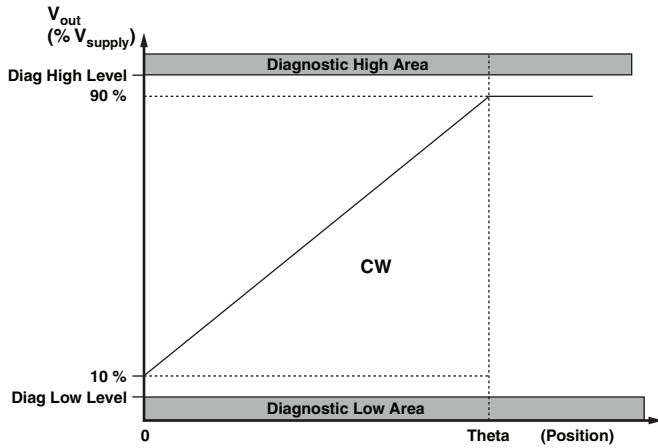

**V<sub>OUT</sub> PWM**

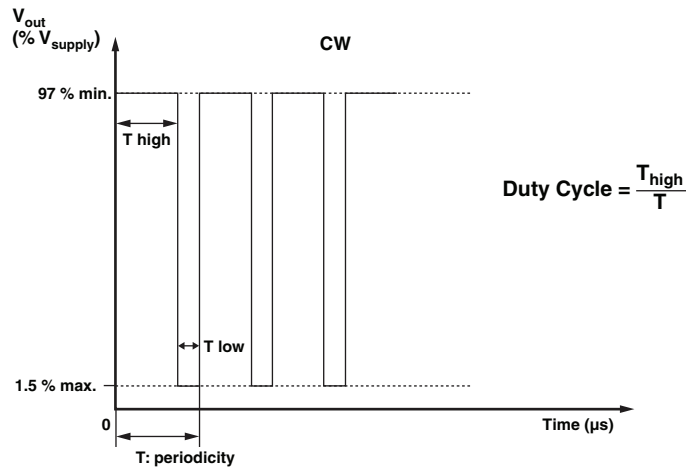

DIAGNOSTIC MODES			
FAILURE	$V_{out}$ Analog $R_{pull-up}$	$V_{out}$ Analog $R_{pull-down}$	$V_{out}$ PWM $R_{pull-up} = 1\text{ k}\Omega$ $V_{pull-up} = V_{supply} = 5\text{ V}$
1: Broken GND	Diagnostic high area	Diagnostic low area	> 97 % $V_{supply}$ without modulation
2: Broken $V_{out}$	Diagnostic high area	Diagnostic low area	> 97 % $V_{supply}$ without modulation
3: Broken $V_{supply}$	Diagnostic high area	Diagnostic low area	> 97 % $V_{supply}$ without modulation
Over Voltage $V_{supply} > 7\text{ V}$	Diagnostic high area	Diagnostic low area	> 97 % $V_{supply}$ without modulation
Under Voltage $V_{supply} < 2.7\text{ V}$	Diagnostic high area	Diagnostic low area	> 97 % $V_{supply}$ without modulation

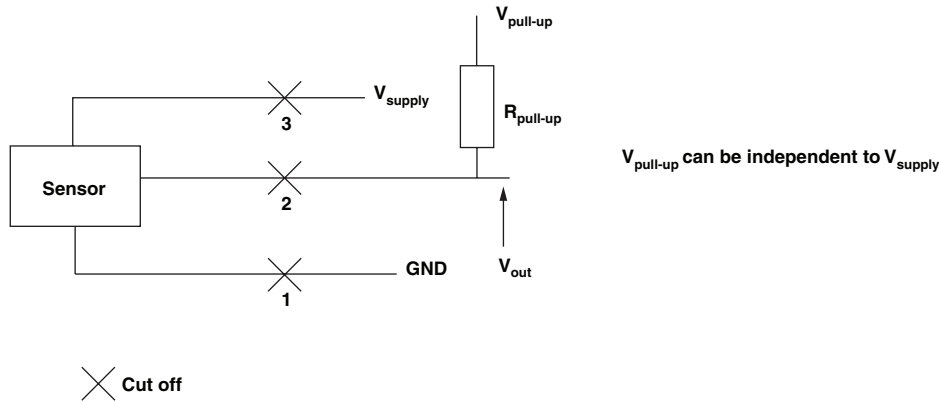

ENVIRONMENTAL SPECIFICATIONS	
Vibrations	20 G from 10 Hz to 2000 Hz
Shocks	3 shocks/axis; 50 G half a sine 11 ms
Operating Temperature Range	- 45 °C; + 125 °C
Life	20M of cycles
Rotational Speed (Max.)	120 RPM
Immunity to Radiated Electromagnetic Disturbances	200 V/m 150 kHz/1 GHz
Immunity to Power Frequency Magnetic Field	200 A/m 50 Hz/60 Hz
Radiated Electromagnetic Emissions	30 MHz/1 GHz < 30 dB $\mu\text{V/m}$
Electrostatic Discharges	Contact discharges: $\pm 4\text{ kV}$ Air discharges: $\pm 8\text{ kV}$
<b>Materials</b>	
Housing	Aluminum anodized
Shaft	Stainless steel
Output	3 lead wires
Bushings Mount Hardware	
Lockwasher Internal Tooth	Steel nickel plated
Panel Nut	Brass nickel plated



**DIMENSIONS** in millimeters

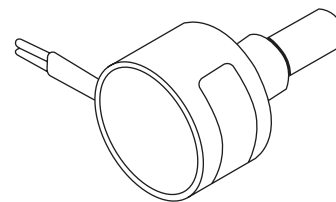
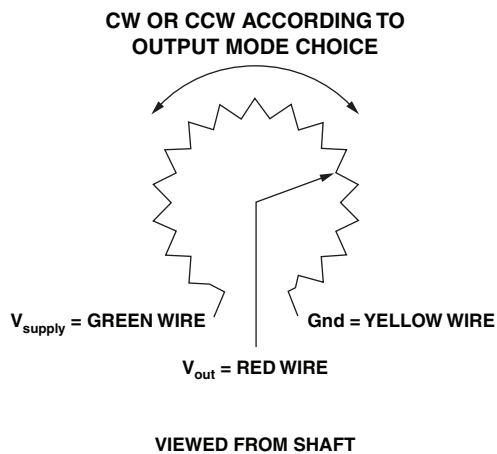
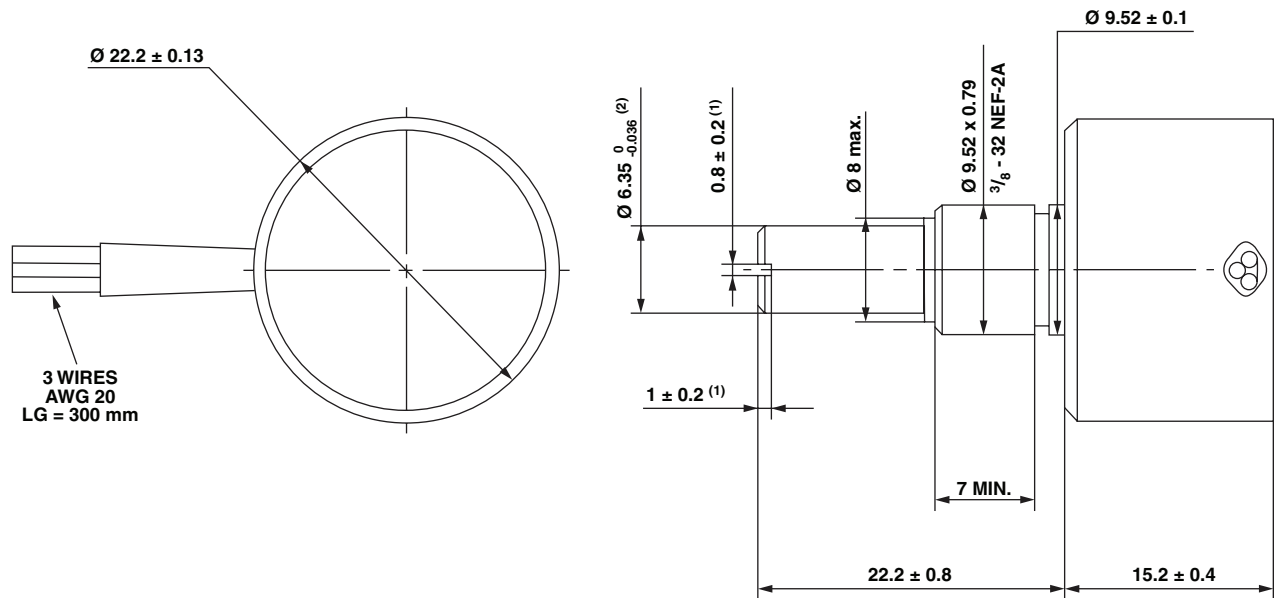

**Dimensions** in millimeter  
Delivered with nut and washer

**Notes:**  
(1) For version slotted shaft  
(2) For shaft type "1"

<b>MARKING</b>	
<b>Unit Identification</b>	Manufacturer's name and complete sap part reference, date code, and wiring correspondance: colors versus connections.





# Accessories

## Dials



### Contents

Model 11 .....	172
Model 15 .....	173
Model 18 .....	174
Model 21 .....	175
Model 21P .....	176
Model 23 .....	177
Model 25 .....	178
Model 26 .....	179
Model 28 .....	180

---



### 25.4 mm Diameter Eleven Turn Dial



#### FEATURES

- Round vernier scale
- 1" diameter
- 1/4" or 1/8" shaft adapter
- Black chrome finish with white markings
- Brushed chrome finish with black markings
- Satin chrome finish with black or white markings



MECHANICAL SPECIFICATIONS	
PARAMETER	
Runout	Dial to be free running and without binds, with axis of drive sleeve perpendicular or in any position within 0.004 per inch (0.10) out of perpendicular with the mounting face
Mounting	Directly to shaft with #2 - 56 spline socket set screw. Drive sleeve set screw on lower side of vertical center line with a graduated circular dial reading of 0
Numeral Size	0.075 height (1.90) x 0.013 width (0.33) of line
Graduation Size:	
Numeral	0.040" L (1.02 cm)
Intermediate	0.030" L (0.76 cm)
Width	0.010" (0.25 cm)
Weight	0.7 oz. max. (19.84 g)

OPERATIONAL SPECIFICATIONS	
Indication	Single counter type wheel and a graduated circular dial registering a total count of 11 turns
Operation	Single numeral in window (0 thru 10) indicates completed number of turns of the drive sleeve. Graduated circular dial indicates the percent of the partial turn of the drive sleeve
Transfer Point	Between 97 and 0
Rotation	
Increasing Indication	CW direction
Decreasing Indication	CCW direction
Accuracy	Zero backlash between dial and the drive sleeve

#### DIMENSIONS in inches (millimeters)

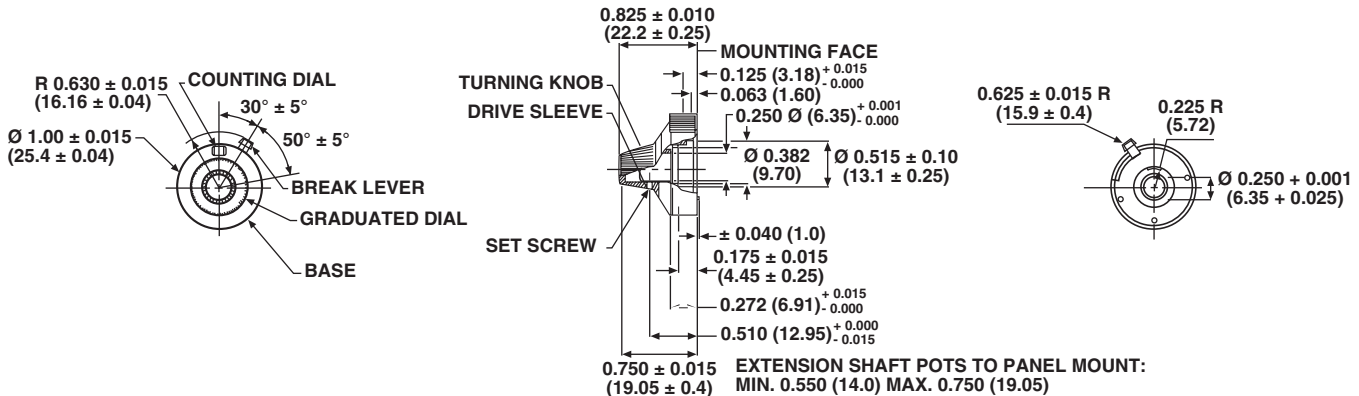

ORDERING INFORMATION/DESCRIPTION				
11	A	11	BO10	e
MODEL	SHAFT DIAMETER	FINISH AND OTHER FEATURES	PACKAGING	LEAD FINISH
	A 1/4" Shaft (standard) B 1/8" Shaft adapter	11. Satin chrome, black markings 21. Black chrome, white markings 31. Brushed chrome, black markings 41. Satin chrome, white markings		
Example: 11 - A - 11				

SAP PART NUMBERING GUIDELINES			
11	A	11	B10
MODEL	SHAFT DIAMETER	FINISH	PACKAGING



## Rectangular 10 Turn Dial (3 Digit), (4 Digit) 100 Turn



### FEATURES

- Rectangular digital scale
- 1" wide
- 1/4" or 1/8" or metric (6 mm) shaft adapter
- Open or clear plastic window bezel
- Black anodize finish with standard or white bezel trim
- Satin clear anodize finish



MECHANICAL SPECIFICATIONS	
PARAMETER	
Numerals	The numerals shall be white on a black background and 0.130" H (3.30 cm)
Mounting	The spring detented knob shall be removed using a straight pull, exposing two No. 4-40 hex socket set screws for mounting the dial directly to the component shaft
Weight	1.6 oz. (45.36 g)

OPERATIONAL SPECIFICATIONS	
Operation 3 Digit (10 turn) Left Digit Right Two Digits	Complete revolutions of turning knob Percent of revolution The unit registers a total count of 999
Operation 4 Digit (100 Turn) Left Two Digits Right Two Digits	Complete revolutions of turning knob Percent of revolution The unit registers a total count of 9999
Rotation	The indication shall increase with clockwise rotation of the turning knob
Accuracy	Graduation lines adjacent to the numerals on the right digit wheel indicate settings 0.2 % of a revolution of the turning knob
Phasing	Dial phased by rotating the exposed component shaft to correspond with the desired reading on the dial prior to tightening the set screws

### DIMENSIONS in inches (millimeters)

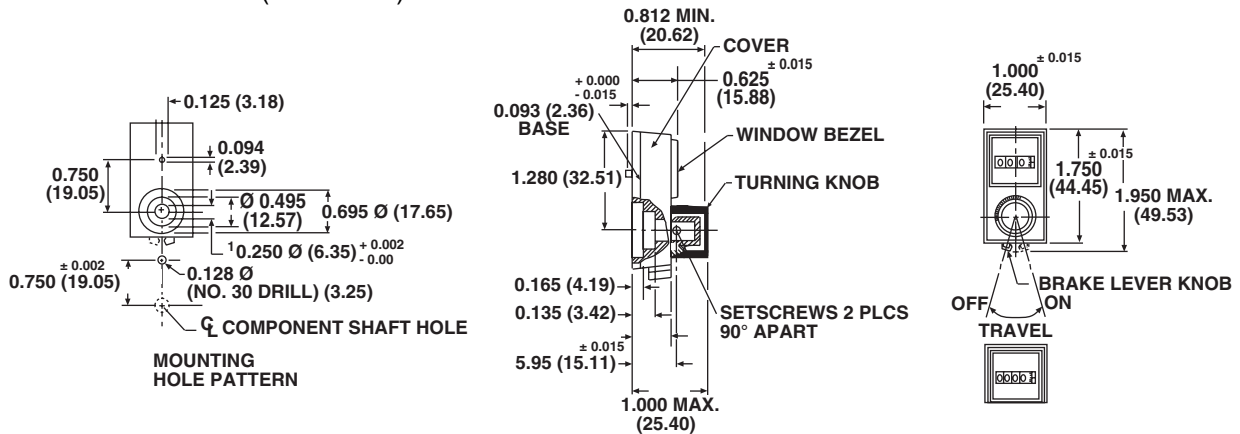

ORDERING INFORMATION/DESCRIPTION					
15	A	1	1	B010	e
MODEL	SHAFT DIAMETER AND NUMERICAL DISPLAY	BEZEL	FINISH	PACKAGING	LEAD FINISH
Example: 15 - A - 1 - 1	<b>A</b> 1/4" dia. 3 digit <b>B</b> 1/4" dia. 4 digit <b>C</b> 1/8" dia. 3 digit <b>D</b> 1/8" dia. 4 digit <b>E</b> 6 mm dia. 3 digit <b>F</b> 6 mm dia. 4 digit	<b>1.</b> Open <b>3.</b> Clear plastic window	<b>1.</b> Satin clear anodize <b>3.</b> Black anodize, white bezel trim <b>5.</b> Black anodize		

SAP PART NUMBERING GUIDELINES				
15	A	1	1	B10
MODEL	SHAFT DIAMETER	BEZEL	FINISH	PACKAGING

## Model 18 (PR2) 22.2 mm Diameter, 15 Turn Dial



**FEATURES**

- No backlash
- Compact-requires minimal panel space (22.2 mm diameter requirement)
- For use with precision potentiometers or other rotating devices, up to 15 turns
- Designed for metal shaft
- High force “Click Brake”
- Black color on request



MECHANICAL SPECIFICATIONS	
Accepts Shaft Diameter	6.35 mm (0.250")/6 mm/3.17 mm (0.125")/3 mm
Number of Turns	0 to 15
Dial Division	50 per turn
Torque with Brake Engaged	5 oz. - in (350 gr - cm) min.
Markings	Black or satin chrome
Weight	15 g
Set Srew	UNC 2-56
Hex Key Size	1.27 mm (0.05")
Bushing Extension Beyond Panel	6.35 mm (0.250") max.
Shaft Extension Beyond Panel	18.1 mm (0.710") min. 22.2 mm (0.875") max.

**DIMENSIONS** in millimeters (inches)

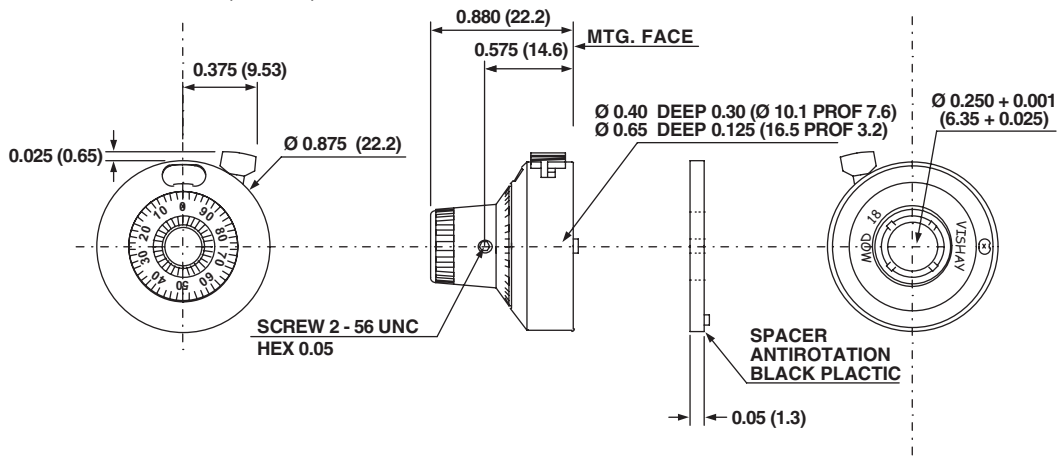

ORDERING INFORMATION/DESCRIPTION				
18	A	11	B010	e
MODEL	SHAFT DIAMETER ACCOMODATION AND FIXINGS	FINISH	PACKAGING	LEAD FINISH
<b>A</b> 1/4" dia. shaft - 1 set screw <b>B</b> 6 mm metric bore - 1 set screw <b>C</b> 1/8" dia. shaft - 1 set screw <b>D</b> 3 mm metric bore - 1 set screw		<b>11</b> Satin chrome, black markings (standard) <b>21</b> Black chrome, white markings <b>41</b> Satin chrome, white markings		
Example: 18 - A - 11				

SAP PART NUMBERING GUIDELINES			
18	A	11	B10
MODEL	SHAFT DIAMETER	FINISH	PACKAGING

## 46.02 mm Diameter 15 Turn Dial



### FEATURES

- Round vernier scale
- 1 13/16" dia.
- 1/4" or 1/8" or 6 mm metric bore shaft adapter
- Satin chrome finish with black markings
- Black chrome finish with white markings
- Brushed chrome finish with black markings



MECHANICAL SPECIFICATIONS	
PARAMETER	
Mounting	Direct to shaft with # 4 - 40 hex socket set screw located adjacent to No.75 on graduated dial.
Numeral Size: Counter Wheel: Graduated Dial:	0.90 H x 0.013" W (2.29 x 0.33 cm) 0.109 x 0.018" (2.77 x 0.46 cm)
Graduation Size: Numerals and Every Fifth Intermediate Width	0.55" L (1.40 cm)  0.035" L (0.89 cm) 0.012" (0.30 cm)
Weight	3.0 max. (85.05)

OPERATIONAL SPECIFICATIONS	
Readout and Operation	1499 turns total The number in window (0 thru 14) indicates completed number of turns of the drive sleeve. Graduated circular dial indicates the percent of the partial turn of the drive sleeve
Transfer Point	The number in center of window shall change as graduated dial rotates between 94 and 0
Rotation	Readout shall increase with clockwise and decrease with counterclockwise rotation
Accuracy	Zero backlash between graduated dial and the drive sleeve

### DIMENSIONS in inches (millimeters)

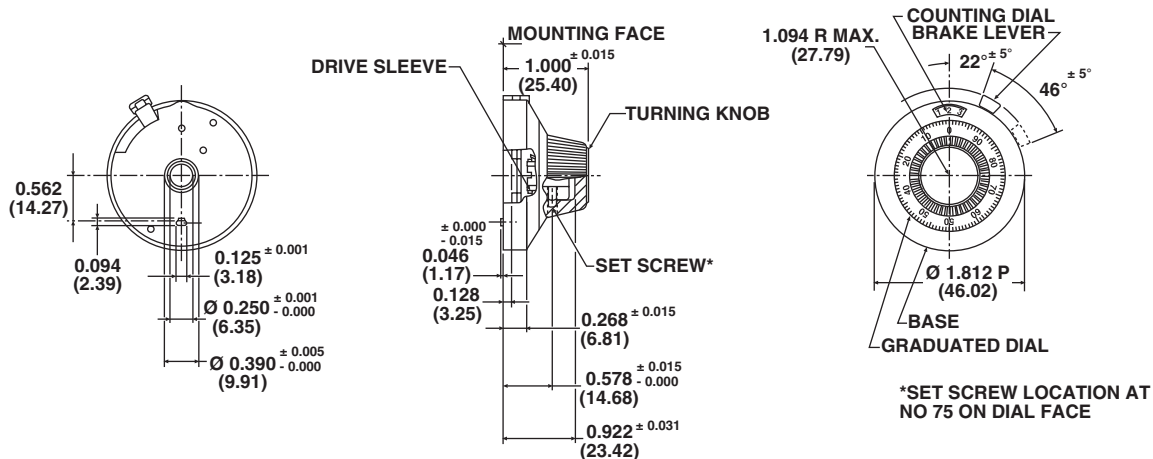

ORDERING INFORMATION/DESCRIPTION				
21	A	11	B010	e
MODEL	SHAFT DIAMETER AND ACCOMODATION	FINISH AND OTHER FEATURES	PACKAGING	LEAD FINISH
	A 1/4" Shaft (standard) B 6 mm metric bore shaft adapter C 1/8" Shaft adapter	11. Satin chrome, black markings 21. Black chrome, white markings 31. Brushed chrome, black markings		

Example: 21 - A - 11

SAP PART NUMBERING GUIDELINES			
21	A	11	B10
MODEL	SHAFT DIAMETER	FINISH	PACKAGING

## 46.0 mm Diameter Eleven Turn Dial



### FEATURES

- Round vernier scale
- 1 13/16" dia. (46.0 mm)
- Material: Plastic ABS mold
- Finish: Metallized clear (aluminum)



MECHANICAL SPECIFICATIONS	
Mounting	Direct to shaft with # 4 - 40 unc hext socket set screw located adjacent to No. 75 on graduated dial
Numeral Size: Counter Wheel Graduated Dial	1/12 x 1/16" (2.0 x 1.6 mm) 1/8 x 1/12" (3.2 x 2.0 mm)
Graduation Size: Numeral and Every Fifth Intermediate Width	1/12" (2.0 mm) 1/24" (1.0 mm) 0.01" (0.2 mm)
Weight	13 g

OPERATIONAL SPECIFICATIONS	
Readout and Operation	1099 turns total The number in window (0 thru 10) indicates completed number of turn of the drive sleeve. Graduated circular dial indicates the percent of the partial turn of the drive sleeve
Transfer Point	The number in center of window shall change as graduated dial rotates between 98 and 0
Rotation	Readout shall increase with CW and decrease with CCW rotation
Accuracy	Zero backlash between graduated dial and drive sleeve

### DIMENSIONS in millimeters (inches)

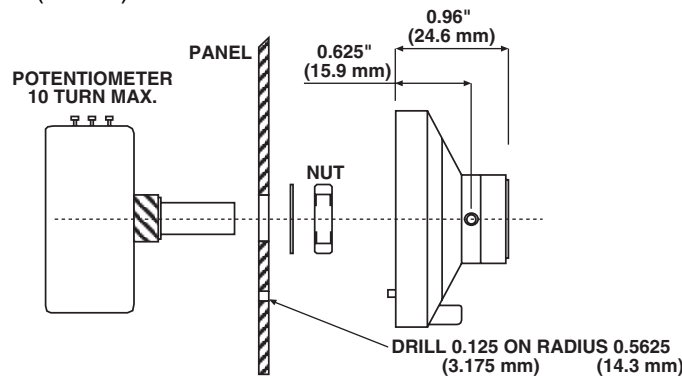

ORDERING INFORMATION/DESCRIPTION				
21P	A	11	BO10	e
MODEL	SHAFT DIAMETER AND ACCOMODATION	FINISH	PACKAGING	LEAD FINISH
	A 1/4" shaft (standard) B 6 mm shaft	Metallized clear (aluminium)		
Example: 21P - A - 11				

SAP PART NUMBERING GUIDELINES			
21P	A	11	B10
MODEL	SHAFT DIAMETER	FINISH	PACKAGING

## Multidial 10 Turns 30.6 mm Diameter Projecting Design



23-1-21 Projecting  
L. 31.5 mm

### FEATURES

- Black body, satin face with chrome ring
- White three digit markings on black background
- Additional graduations for fine adjustment
- Protective window
- Locking lever for fixed position
- Suitable for 6.35 mm shafts
- Supplied with locking key and mounting instructions



### DIMENSIONS in inches (millimeters)

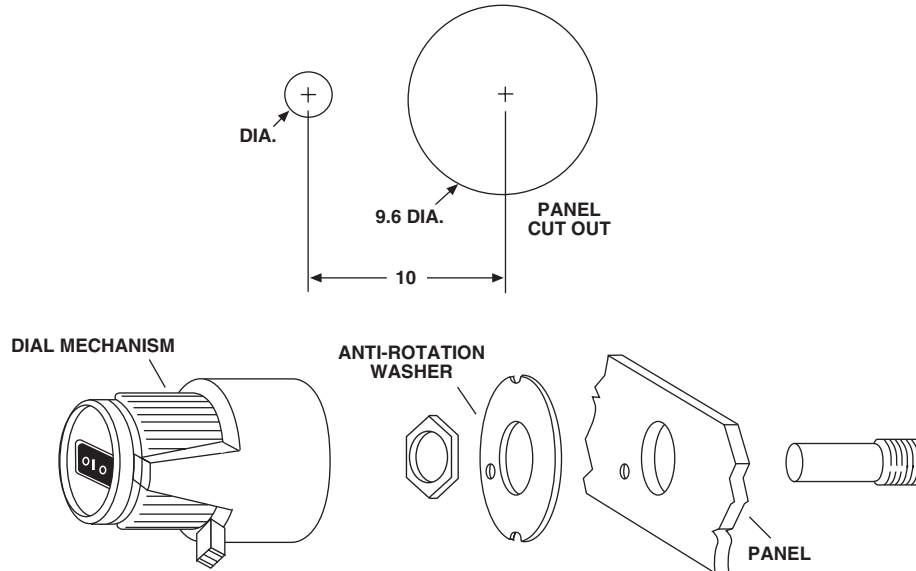

ORDERING INFORMATION/DESCRIPTION				
<b>23</b>	<b>A</b>	<b>21</b>	<b>B050</b>	<b>e</b>
MODEL	1/4" SHAFT	BLACK BODY Satin face with chrome ring	PACKAGING	LEAD FINISH

SAP PART NUMBERING GUIDELINES			
<b>23</b>	<b>A</b>	<b>21</b>	<b>B50</b>
MODEL	SHAFT DIAMETER	FINISH	PACKAGING

## Model 25 (PR1) 46 mm Diameter, 20 Turn Dial



### FEATURES

- Large package size
- For use with precision potentiometers or other devices, up to 20 turns
- Excellent readability
- Precision feel - no backlash
- Cast housing



MECHANICAL SPECIFICATIONS	
Accepts Shaft Diameter	6.35 mm (0.250")/6 mm/3.17 (0.125")/3 mm
Number of Turns	0 to 20
Dial Division	100 per turn
Torque with Brake Engaged	5 oz. - in (350 g - cm) min.
Markings	Black on satin chrome
Weight	75 g
Set Srew	UNC 4-40
Hex Key Size	1.27 mm (0.05")
Bushing Extension Beyond Panel	6.35 mm (0.250") max.
Shaft Extension Beyond Panel	18.1 mm (0.710") min. 22.5 mm (0.925") max.

### DIMENSIONS in millimeters (inches)

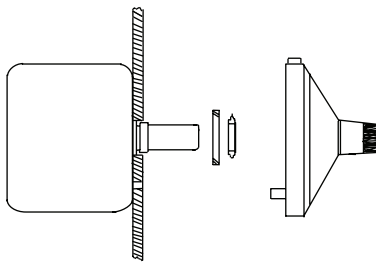

#### Using the existing Antirotation Lug

1. Drill 3.2 mm (0.125) diameter antirotation pin hole on vertical centerline 14.3 mm (0.562) below center of potentiometer mounting hole.
2. Mount potentiometer shaft counterclockwise to obtain minimum resistance or voltage ratio. This is not necessarily identical with the mechanical stop.
4. Loosen set screws in knob of dial. Set dial. Set dial to "0.0" reading.
5. While holding outer ring of dial, position unit lightly against panel. Tighten knob set screws to potentiometer shaft.

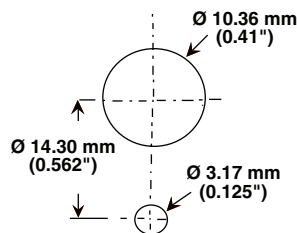

PANEL HOLE PATTERN

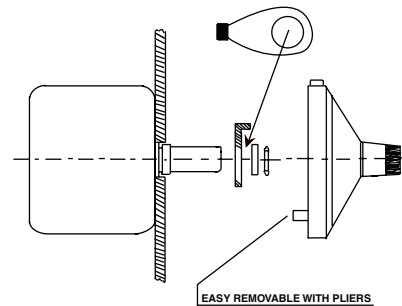

#### Using the Antirotation Device

1. Remove antirotation lug from dial by using pliers.
2. Mount potentiometer in panel with antirotation device nut (supplied with dial) and lockwasher (supplied with potentiometer).
3. Turn potentiometer shaft counterclockwise to obtain minimum resistance or voltage ratio. This is not necessarily identical with the mechanical stop.
4. Loosen screws in knob of dial. Set dial to "0.0" reading.
5. While holding outer ring of dial, position unit lightly against panel. Tighten knob set screws to potentiometer shaft.

EASY REMOVABLE WITH PLIERS

ORDERING INFORMATION/DESCRIPTION				
25	A	11	B010	e
MODEL	SHAFT DIAMETER ACCOMMODATION AND FIXINGS	FINISH	PACKAGING	LEAD FINISH
	A 1/4" dia. shaft - 1 set screw B 6 mm metric bore - 1 set screw C 1/8" dia. shaft - 1 set screw D 3 mm metric bore - 1 set screw	11 Satin chrome, black markings (standard) 21 Black chrome, white markings 41 Satin chrome, white markings		
Example: 25 - A - 11				

SAP PART NUMBERING GUIDELINES			
25	A	11	B10
MODEL	SHAFT DIAMETER	FINISH	PACKAGING

## Multidial 10 Turns 30.6 mm Diameter Recessed Design



26-1-21 Recessed  
L. 15 mm (from panel)  
L. 31.5 mm (total)

### FEATURES

- Black body, satin face with chrome ring
- White three digit markings on black background
- Additional graduations for fine adjustment
- Protective window
- Locking lever for fixed position
- Suitable for 6.35 mm shafts
- Supplied with locking key and mounting instructions



### DIMENSIONS in inches (millimeters)

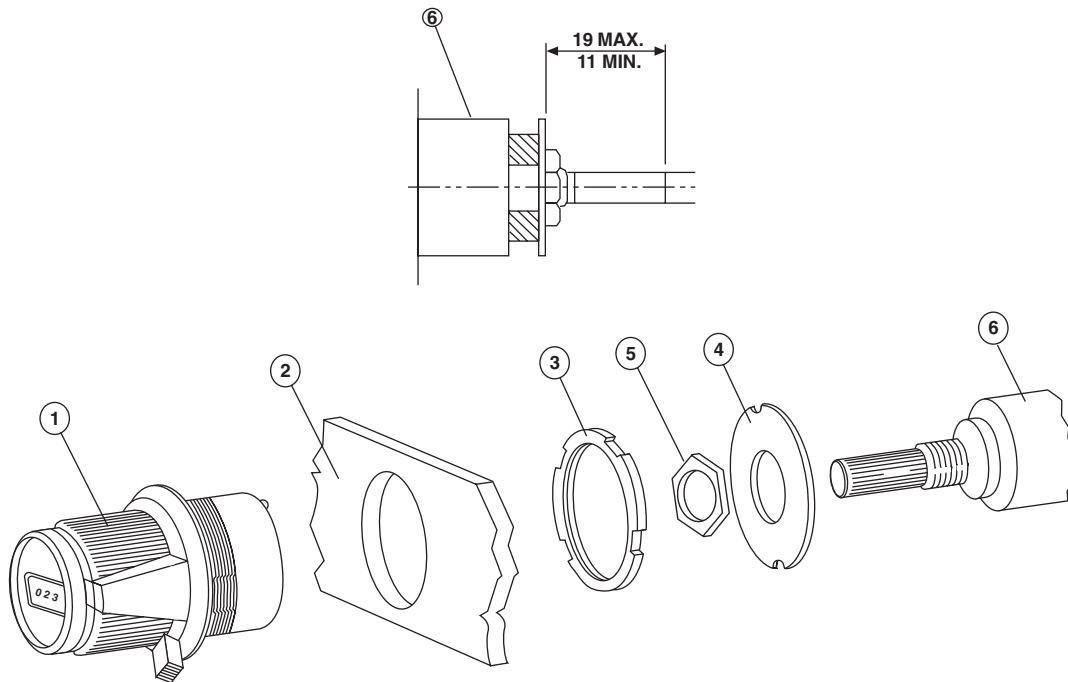

ORDERING INFORMATION/DESCRIPTION				
26	A	21	B050	e
MODEL	1/4" SHAFT	BLACK BODY Satin face with chrome ring	PACKAGING	LEAD FINISH

SAP PART NUMBERING GUIDELINES			
26	A	21	B50
MODEL	SHAFT DIAMETER	FINISH	PACKAGING



## 28 mm Diameter Twenty-One Turn Dial

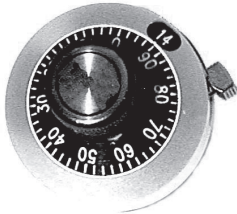

### FEATURES

- Laser machined markings (e.g. logo) per customer design
- Shaft bore variations available
- Special mounting spacers



MECHANICAL SPECIFICATIONS	
PARAMETER	
Temperature Range	- 20 to + 50 °C
Operating Torque	0.75 oz. - in max.
Weight	23 g
Housing	Metal housing treated against corrosion
Finish	Aluminum anodized
Bearing	Precision ball bearing for uniform movement

TECHNICAL SPECIFICATIONS	
Readout and Operation	21 turns total The number in the window (0 thru 20) indicates the percent of a partial turn of the drive sleeve
Brake Lever	Metal brake operates a high torque system which actuates brake
MARKING	
Unit Identification	Manufacturer's name and model number

### DIMENSIONS in millimeters (inches)

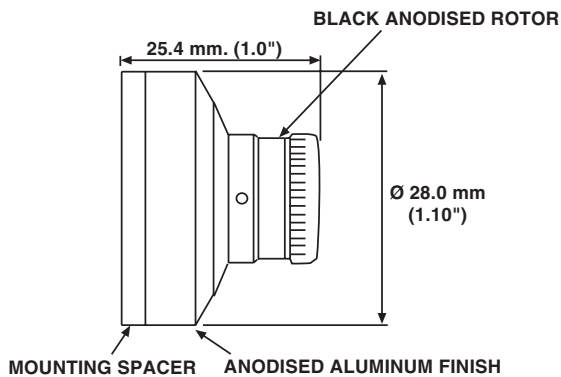
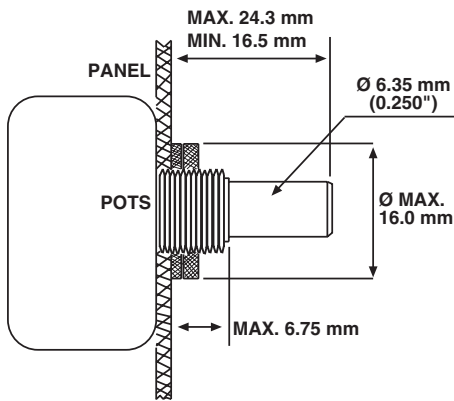

ORDERING INFORMATION/DESCRIPTION				
28	A	11	B08	e
MODEL	SHAFT DIAMETER	FINISH	PACKAGING	LEAD FINISH
	A 1/4" dia. shaft - 1 set screw B 6 mm metric bore - 1 set screw C 1/8" dia. shaft - 1 set screw	11. Clear satin anodized housing, black rotor, white markings 21. Black anodized housing, black rotor, white markings		
Example: 28 - A - 11				

SAP PART NUMBERING GUIDELINES			
28	A	11	B08
MODEL	SHAFT DIAMETER	FINISH	PACKAGING





## ONLINE INFORMATION

For product information and a current list of sales offices,  
representatives and distributors, visit our website:

[www.vishay.com](http://www.vishay.com)

### WORLDWIDE SALES CONTACTS

#### THE AMERICAS

##### UNITED STATES

VISHAY AMERICAS  
ONE GREENWICH PLACE  
SHELTON, CT 06484  
UNITED STATES  
PH: +1-402-563-6866  
FAX: +1-402-563-6296

##### ASIA

##### SINGAPORE

VISHAY INTERTECHNOLOGY  
ASIA PTE LTD.  
25 TAMPINES STREET 92  
KEPPEL BUILDING #02-00  
SINGAPORE 528877  
PH: +65-6788-6668  
FAX: +65-6788-0988

##### P.R. CHINA

VISHAY TRADING (SHANGHAI) CO., LTD.  
15D, SUN TONG INFOPORT PLAZA  
55 HUAI HAI WEST ROAD  
SHANGHAI 200030  
P.R. CHINA  
PH: +86-21-5258-5000  
FAX: +86-21-5258-7979

##### JAPAN

VISHAY JAPAN CO., LTD.  
MG IKENOHATA BLDG. 4F  
1-2-18, IKENOHATA  
TAITO-KU  
TOKYO 110-0008  
JAPAN  
PH: +81-3-5832-6210  
FAX: +81-3-5832-6260

#### EUROPE

##### GERMANY

VISHAY EUROPE SALES GMBH  
GEHEIMRAT-ROSENTHAL-STR. 100  
95100 SELB  
GERMANY  
PH: +49-9287-71-0  
FAX: +49-9287-70435

##### FRANCE

VISHAY S.A.  
199, BLVD DE LA MADELEINE  
06003 NICE, CEDEX 1  
FRANCE  
PH: +33-4-9337-2920  
FAX: +33-4-9337-2997

##### UNITED KINGDOM

VISHAY LTD.  
PALLION INDUSTRIAL ESTATE  
SUNDERLAND SR4 6SU  
UNITED KINGDOM  
PH: +44-191-514-4155  
FAX: +44-191-567-8262

One of the World's Largest

**Manufacturers**

of Discrete Semiconductors and Passive Components



**World Headquarters**

Vishay Intertechnology, Inc.  
63 Lancaster Avenue  
Malvern, PA 19355-2143  
United States

One of the World's Largest  
**Manufacturers**

of Discrete Semiconductors and Passive Components



PRECISION POTENTIOMETERS, INDUSTRIAL SENSORS

DATA BOOK

Copyright © 2008 by Vishay Intertechnology, Inc.  
Registered Trademarks of Vishay Intertechnology, Inc.  
All rights reserved. Printed in Germany.  
Specifications subject to change without notice.

[www.vishay.com](http://www.vishay.com)

VSE-DB0100-0802