

# Industrial Networking Ethernet & Cellular M2M

## Products, Topologies & Glossary of Terms



# A Message from the President



*"As we bring Red Lion, N-Tron and Sixnet together, our promise to you is that we shall become a better company, and not just a bigger one."*

**Mike Granby**  
**President, Red Lion Controls**

Please allow me to start by saying thank you to the thousands of customers all over the world who place their trust in the products and reputation of Red Lion, N Tron and Sixnet: We appreciate your business and look forward to serving you at even higher levels in the future.

We are currently in the middle of exciting changes, as we take the steps towards bringing N-Tron and Sixnet together as part of a bigger, better Red Lion. Each company has its own legacy and its own strengths, and together we offer an industry-leading portfolio of products and solutions. The long and trusted history of Red Lion and Sixnet in the automation market is a perfect complement to N-Tron's mastery of industrial networking, and to Sixnet's recent developments in the fields of cellular and machine-to-machine communications.

As we bring Red Lion, N-Tron and Sixnet together, our promise to you is that we shall become a better company, and not just a bigger one. We recognize that you, the customer, is what matters, and that our merger only makes sense if it is able to put better solutions and better products in your hands. We are dedicated to becoming the global experts in communication, monitoring and control for industrial automation and networking—and to doing so with the exceptional levels of service for which Red Lion is well known.

In addition to the panel meters, HMIs and other industrial automation products that Red Lion customers have always trusted, we now have a broad selection of communication technologies for industrial networks, ranging from industrial Ethernet, through WiFi to complete cellular M2M solutions.

And the end result? A comprehensive set of products that enable you to connect, monitor and control anything. From one device to a thousand devices. Connecting serially, via Ethernet, or over high-speed wireless networks. Speaking one protocol, or hundreds of protocols. On a single machine, across your factory, or spanning multiple sites all over the globe.

Thank you again, and join us on our journey as Red Lion, N-Tron and Sixnet become better, together.



# Table of Contents

## Ethernet Switches

- 4** Unmanaged Ethernet Switches
- 6** Monitored Ethernet Switches
- 8** Managed Ethernet Switches
- 10** Advanced Managed Ethernet Switches
- 11** Power over Ethernet (PoE) Solutions
- 12** IP67 Switches

## Wireless Networking

- 13** Wi-Fi Radios

- 14** Cellular M2M Routers

## Communication Converters

- 16**

## Topologies

- 18**

## Glossary

- 26**

## Ethernet Switches

Red Lion's new N-Tron and Sixnet series industrial Ethernet switches are designed to meet diverse networking environments. Built-in redundancy coupled with robust reliability ensures infrastructures like yours stay up and running around the clock. Red Lion provides uptime anywhere so you can get the most out of your network investment.

- > Unmanaged Ethernet Switches
- > Monitored Ethernet Switches
- > Managed Ethernet Switches
- > Advanced Managed Ethernet Switches
- > PoE Solutions
- > IP67 Switches



## ▶▶▶ Unmanaged Ethernet Switches

Red Lion's unmanaged industrial Ethernet switches offer powerful network performance with plug-and-play functionality. With an endless range of port options, these unmanaged switches are set to tackle the demands of industrial data acquisition, control and Ethernet I/O applications.

- > Compact IEEE 802.3 Layer 2 industrial switches
- > Automatic speed
- > Duplex and cable sensing
- > For use in mission-critical applications
- > Plug-and-play functionality



### Sixnet Series SL & SLX Fast Ethernet (10/100)

- > Robust-edge devices
- > Flexible deployment options
- > Industrial rated



PART NUMBER	TYPE	TOTAL PORTS	FAST ETHERNET		MOUNTING & CASE	OPERATING TEMP
			10 / 100	100 FIBER		
SL-2ES-2/3	Unmanaged	2	1	1	DIN rail – Lexan	-10 to 60° C
SL-5ES-1	Unmanaged	5	5	-	DIN rail – Lexan	-40 to 60° C
SL-5ES-2/3	Unmanaged	5	4	1	DIN rail – Lexan	-40 to 60° C
SL-6ES-4/5	Unmanaged	6	4	2	DIN rail – Lexan	-40 to 60° C
SL-8ES-1	Unmanaged	8	8	-	DIN rail – Lexan	-40 to 60° C
SL-9ES-2/3	Unmanaged	9	8	1	DIN rail – Lexan	-40 to 60° C
SLX-3ES-2/3	Unmanaged	3	2	1	DIN rail – Metal	-40 to 85° C
SLX-5ES-1	Unmanaged	5	5	-	DIN rail – Metal	-40 to 85° C
SLX-5ES-2/3	Unmanaged	5	4	1	DIN rail – Metal	-40 to 85° C
SLX-6ES-4/5	Unmanaged	6	4	2	DIN rail – Metal	-40 to 85° C
SLX-8ES-1	Unmanaged	8	8	-	DIN rail – Metal	-40 to 85° C
SLX-8ES-6/7	Unmanaged	8	5	3	DIN rail – Metal	-40 to 85° C
SLX-9ES-2/3	Unmanaged	9	8	1	DIN rail – Metal	-40 to 85° C

## N-Tron Series 100, 300 & 500 Entry-Level Fast Ethernet (10/100)

- > Compact, rugged design
- > Increases network bandwidth
- > Industrial rated



PART NUMBER	TYPE	TOTAL PORTS	FAST ETHERNET		MOUNTING & CASE	OPERATING TEMP
			10 / 100	100 FIBER		
102MC	Unmanaged	2	1	1	DIN rail – Metal	-40 to 80° C
104TX	Unmanaged	4	4	-	DIN rail – Metal	-40 to 80° C
105TX	Unmanaged	5	5	-	DIN rail – Metal	-40 to 80° C
105TX-SL	Unmanaged	5	5	-	DIN rail – Metal	-40 to 85° C
105FX	Unmanaged	5	4	1	DIN rail – Metal	-40 to 70° C
106FX2	Unmanaged	6	4	2	DIN rail – Metal	-40 to 70° C
108TX	Unmanaged	8	8	-	DIN rail – Metal	-40 to 70° C
110FX2	Unmanaged	10	8	2	DIN rail – Metal	-40 to 80° C
111FX3	Unmanaged	11	8	3	DIN rail – Metal	-40 to 80° C
112FX4	Unmanaged	12	8	4	DIN rail – Metal	-40 to 80° C
114FX6	Unmanaged	14	8	6	DIN rail – Metal	-40 to 80° C
116TX	Unmanaged	16	16	-	DIN rail – Metal	-40 to 85° C
302MC	Unmanaged	2	1	1	DIN rail – Metal	-40 to 70° C
304TX	Unmanaged	4	4	-	DIN rail – Metal	-40 to 70° C
305FX	Unmanaged	5	4	1	DIN rail – Metal	-40 to 70° C
306TX	Unmanaged	6	6	-	DIN rail – Metal	-40 to 70° C
308TX	Unmanaged	8	8	-	DIN rail – Metal	-40 to 70° C
316TX	Unmanaged	16	16	-	DIN rail – Metal	-40 to 85° C
306FX2	Unmanaged	6	4	2	DIN rail – Metal	-40 to 70° C
308FX2	Unmanaged	8	6	2	DIN rail – Metal	-40 to 85° C
309FX	Unmanaged	9	8	1	DIN rail – Metal	-40 to 85° C
317FX	Unmanaged	17	16	1	DIN rail – Metal	-40 to 85° C
508TX	Unmanaged	8	8	-	DIN rail – Metal	-40 to 85° C
508FX2	Unmanaged	8	6	2	DIN rail – Metal	-40 to 85° C
509FX	Unmanaged	9	8	1	DIN rail – Metal	-40 to 85° C
516TX	Unmanaged	16	16	-	DIN rail – Metal	-40 to 85° C
517FX	Unmanaged	17	16	1	DIN rail – Metal	-40 to 85° C
524TX	Unmanaged	24	24	-	DIN rail – Metal	-40 to 85° C
526FX2	Unmanaged	26	24	2	DIN rail – Metal	-40 to 85° C

## N-Tron Series 1000 & Sixnet SLX Unmanaged Gigabit (10/100/1000)

- > Plug-and-play unmanaged operation
- > Gigabit speed port options
- > Industrial rated



PART NUMBER	TYPE	TOTAL PORTS	FAST ETHERNET		GIGABIT ETHERNET		MOUNTING & CASE	OPERATING TEMP
			10 / 100	100 FIBER	10 / 100/ 1000	GIG FIBER		
1002MC	Unmanaged	2	-	-	1	1 SFP	DIN rail – Metal	-40 to 85° C
1003GX2	Unmanaged	3	-	-	1	2 SFP	DIN rail – Metal	-40 to 85° C
1005TX	Unmanaged	5	-	-	5	-	DIN rail – Metal	-40 to 85° C
SLX-3EG-1SFP	Unmanaged	3	-	-	2	1 SFP	DIN rail – Metal	-40 to 85° C
SLX-5EG-1	Unmanaged	5	-	-	4 PoE	1 SFP	DIN rail – Metal	-40 to 85° C
SLX-5EG-2SFP	Unmanaged	5	-	-	3 PoE	2 SFP	DIN rail – Metal	-40 to 85° C

## ▶▶▶ Monitored Ethernet Switches

Red Lion's monitored industrial Ethernet switches provide network performance monitoring with Modbus or N-View firmware. These rugged, compact switches are built for mission critical standards and provide a very low cost network monitoring solution that can be integrated directly into any industrial control system.

- > Layer 2 unmanaged industrial switches
- > Network performance monitoring via Modbus or N-View software
- > Versatile networking solutions
- > Flexible deployment options
- > Hardened for the toughest applications



### Sixnet Series SL & SLX Ring Fast Ethernet (10/100)

- > Fast, fault-tolerant network redundancy
- > Pre-configured for plug-and-play functionality
- > Industrial design
- > Real-time Modbus over Ethernet monitoring



PART NUMBER	TYPE	TOTAL PORTS	FAST ETHERNET		MOUNTING & CASE	OPERATING TEMP
			10 / 100	100 FIBER		
SL-6RS-1	Ring	6	6	-	DIN rail – Lexan	-40 to 60° C
SL-6RS-4/5	Ring	6	4	2	DIN rail – Lexan	-40 to 60° C
SLX-6RS-1	Ring	6	6	-	DIN rail – Metal	-40 to 85° C
SLX-6RS-4/5	Ring	6	4	2	DIN rail – Metal	-40 to 85° C
SLX-5MS-MDM-1	Switch/ dial up modem	5	-	-	DIN rail – Metal	-40 to 85° C

## N-Tron Series 300 & 500 Monitored Fast Ethernet (10/100)

- > Offers high reliability
- > Plug-and-play operation
- > N-View monitoring provides real-time switch diagnostics



PART NUMBER	TYPE	TOTAL PORTS	FAST ETHERNET		MOUNTING & CASE	OPERATING TEMP
			10 / 100	100 FIBER		
302MC-N	Monitored	2	1	1	DIN rail – Metal	-40 to 70° C
304TX-N	Monitored	4	4	-	DIN rail – Metal	-40 to 70° C
306TX-N	Monitored	6	6	-	DIN rail – Metal	-40 to 70° C
308TX-N	Monitored	8	8	-	DIN rail – Metal	-40 to 70° C
305FX-N	Monitored	5	4	1	DIN rail – Metal	-40 to 70° C
306FX2-N	Monitored	6	4	2	DIN rail – Metal	-40 to 70° C
308FX2-N	Monitored	8	6	2	DIN rail – Metal	-40 to 85° C
309FX-N	Monitored	9	8	1	DIN rail – Metal	-40 to 85° C
316TX-N	Monitored	16	16	-	DIN rail – Metal	-40 to 85° C
317FX-N	Monitored	17	16	1	DIN rail – Metal	-40 to 85° C
508TX-N	Monitored	8	8	-	DIN rail – Metal	-40 to 85° C
516TX-N	Monitored	16	16	-	DIN rail – Metal	-40 to 85° C
508FX2-N	Monitored	8	6	2	DIN rail – Metal	-40 to 85° C
509FX-N	Monitored	9	8	1	DIN rail – Metal	-40 to 85° C
517FX-N	Monitored	17	16	1	DIN rail – Metal	-40 to 85° C
524TX-N	Monitored	24	24	-	Rackmount – Metal	-40 to 85° C
526FX2-N	Monitored	26	24	2	Rackmount – Metal	-40 to 85° C

## N-Tron Series 500 Process Control Fast Ethernet (10/100)

- > Expanded Ethernet communications
- > N-View monitoring provides real-time switch diagnostics
- > Rugged industrial DIN rail and Rackmount options



PART NUMBER	TYPE	TOTAL PORTS	FAST ETHERNET		MOUNTING & CASE	OPERATING TEMP
			10 / 100	100 FIBER		
508TX-A	Process Control	8	8	-	DIN rail – Metal	-40 to 85° C
516TX-A	Process Control	16	16	-	DIN rail – Metal	-40 to 85° C
508FX2-A	Process Control	8	6	2	DIN rail – Metal	-40 to 85° C
509FX-A	Process Control	9	8	1	DIN rail – Metal	-40 to 85° C
517FX-A	Process Control	17	16	1	DIN rail – Metal	-40 to 85° C
524TX-A	Process Control	24	24	-	Rackmount – Metal	-40 to 85° C
526FX2-A	Process Control	26	24	2	Rackmount – Metal	-40 to 85° C

## ▶▶▶ Managed Ethernet Switches

Red Lion's rugged, reliable managed industrial Ethernet switches support industry-standard applications. Our hardened switches are ideally suited for harsh industrial environments where real-time performance under extreme operating conditions is required. Built-in redundancy and network management ensure communications stay up and running while providing tools for monitoring and tracking.

- > Layer 2 Ethernet switches
- > Rugged packaging supports extreme environments
- > Powerful network management
- > Gigabit models available



### Sixnet Series SLX Managed Ethernet

- > Versatile networking solutions
- > Modbus monitoring capable
- > Fast Ethernet and Gigabit port options
- > DIN rail or direct to panel options



PART NUMBER	TYPE	TOTAL PORTS	FAST ETHERNET		GIGABIT ETHERNET		MOUNTING & CASE	OPERATING TEMP
			10 / 100	100 FIBER	10 / 100/ 1000	GIG FIBER		
SLX-5MS-1	Managed	5	5	-	-	-	DIN rail – Metal	-40 to 75° C
SLX-5MS-4/5	Managed	5	3	2	-	-	DIN rail – Metal	-40 to 75° C
SLX-5MS-MDM-1	Managed	5	5	-	-	-	DIN rail – Metal	-40 to 75° C
SLX-8MS-1	Managed	8	8	-	-	-	DIN rail – Metal	-40 to 75° C
SLX-8MS-4/5/8/9	Managed	8	4 or 6	2 or 4	-	-	DIN rail – Metal	-40 to 75° C
SLX-8MG-1 (All Gigabit)	Managed	8	-	Up to 4	8	Up to 4 Combo Ports	DIN rail – Metal	-40 to 75° C
SLX-10MG-1	Managed	10	7	Up to 2	3	Up to 2 Combo Ports	DIN rail – Metal	-40 to 75° C
SLX-16MS-1	Managed	16	16	-	-	-	DIN rail – Metal	-40 to 75° C
SLX-18MG-1	Managed	18	16	Up to 2	2	Up to 2 Combo Ports	DIN rail – Metal	-40 to 75° C



## N-Tron Series 700 & 7000 Managed Ethernet

- > Outstanding management and monitoring features
- > Fast Ethernet and Gigabit port options
- > Ideally suited to use as a Ring Manager



PART NUMBER	TYPE	TOTAL PORTS	FAST ETHERNET		GIGABIT ETHERNET		MOUNTING & CASE	OPERATING TEMP
			10 / 100	100 FIBER	10 / 100/ 1000	GIG SFP		
708TX	Managed	8	8	-	-	-	DIN rail – Metal	-40 to 85° C
708FX2	Managed	8	6	2	-	-	DIN rail – Metal	-40 to 85° C
709FX *	Managed	9	8	1	-	-	DIN rail – Metal	-40 to 70° C
710FX2 *	Managed	10	8	2	-	-	DIN rail – Metal	-40 to 70° C
711FX3 *	Managed	11	8	3	-	-	DIN rail – Metal	-40 to 70° C
712FX4 *	Managed	12	8	4	-	-	DIN rail – Metal	-40 to 70° C
714FX6	Managed	14	8	6	-	-	DIN rail – Metal	-40 to 70° C
716TX	Managed	16	16	-	-	-	DIN rail – Metal	-40 to 70° C
716FX2	Managed	16	14	2	-	-	DIN rail – Metal	-40 to 70° C
7010TX	Managed	10	8	-	-	Up to 2	DIN rail – Metal	-40 to 70° C
7012FX2 *	Managed	12	8	2	-	Up to 2	DIN rail – Metal	-40 to 70° C
7018TX	Managed	18	16	-	-	Up to 2	DIN rail – Metal	-40 to 70° C
7018FX2	Managed	18	14	2	-	Up to 2	DIN rail – Metal	-40 to 70° C
7026TX	Managed	26	24	-	-	Up to 2	DIN rail – Metal	-40 to 80° C
7026TX-AC	Managed	26	24	-	-	Up to 2	DIN rail – Metal	-40 to 80° C
7506GX2 (All Gigabit)	Managed	6	-	-	4	Up to 2	Rackmount – Metal	-40 to 80° C
7900 (Modular)	Managed	26	Up to 24	Up to 16	-	Up to 2	Rackmount – Metal	-20 to 70° C

\* KEMA approved IEC 61850-3 and IEEE 1613 HV models available

## N-Tron Series NT24k Managed Ethernet

- > All Gigabit modular design
- > Robust remote monitoring
- > Smart plug-and-play operation
- > DIN rail and rackmount options
- > Extreme environments



PART NUMBER	TYPE	POWER OPTIONS	TOTAL PORTS	FAST ETHERNET		GIGABIT ETHERNET			OPERATING TEMP
				10 / 100	100 FIBER	10 / 100/ 1000	GIGABIT SFP	GIGABIT FIBER	
NT24k-DC1	Managed	Single 18-49VDC	Up to 24	Up to 24	Up to 24	Up to 24	Up to 24	Up to 24	-40 to 85° C
NT24k-DC2	Managed	Dual 18-49VDC	Up to 24	Up to 24	Up to 24	Up to 24	Up to 24	Up to 24	-40 to 85° C
NT24k-AC1	Managed	Single 90-264VAC / 90-300VDC	Up to 24	Up to 24	Up to 24	Up to 24	Up to 24	Up to 24	-40 to 85° C
NT24k-AC2	Managed	Dual 90-264VAC / 90-300VDC	Up to 24	Up to 24	Up to 24	Up to 24	Up to 24	Up to 24	-40 to 85° C
NT24k-AC1-DC1	Managed	Single 90-264VAC / 90-300VDC & 18-49VDC	Up to 24	Up to 24	Up to 24	Up to 24	Up to 24	Up to 24	-40 to 85° C
NT24k-DR16-DC	Managed	Redundant 18-49VDC	Up to 16	Up to 16	Up to 16	Up to 16	Up to 16	Up to 16	-40 to 75° C
NT24k-DR16-AC	Managed	90-264VAC / 90-300VDC	Up to 16	Up to 16	Up to 16	Up to 16	Up to 16	Up to 16	-40 to 75° C
NT24k-DR24-DC	Managed	Redundant 18-49VDC	Up to 24	Up to 24	Up to 24	Up to 24	Up to 24	Up to 24	-40 to 75° C
NT24k-DR24-AC	Managed	90-264VAC / 90-300VDC	Up to 24	Up to 24	Up to 24	Up to 24	Up to 24	Up to 24	-40 to 75° C

## ▶▶▶ Advanced Managed Ethernet Switches

Red Lion's advanced managed industrial Ethernet switches offer powerful enterprise-class networking with security options that prevent unauthorized access and enable policy enforcement. These powerful switches provide QoS traffic classification and sophisticated multicast controls, reducing traffic and ensuring real-time message delivery. The flexible industrial design is built to support the harshest environments.

- > Layer 2 and Layer 3 Ethernet switches
- > Rugged, enterprise-class networking
- > Advanced security features



### Sixnet Series EL Advanced Managed Ethernet

PART NUMBER	TYPE	POWER OPTIONS	TOTAL PORTS	FAST ETHERNET		GIGABIT ETHERNET		10 GIG	OPERATING TEMP
				10 / 100	100 FIBER	10 / 100/ 1000	GIG SFP		
EL212F-AC-V1 **	Managed	Single 90-300 VDC or 85-264 VAC	12	Up to 8 SFP	Up to 8 SFP	-	Up to 4 SFP (2 Combo)	-	-40 to 85° C
EL212F-DC-V1 **	Managed	Dual Redundant 24/48 VDC	12	Up to 8 SFP	Up to 8 SFP	-	Up to 4 SFP (2 Combo)	-	-40 to 85° C
EL228-AO-1 *	Managed	Single 85-264 VAC or 90-300 VDC	28	Up to 24 SFP	Up to 24 SFP	4	Up to 2 SFP (2 Combo)	-	-40 to 85° C
EL228-AA-1 *	Managed	Dual 85-264 VAC or 90-300 VDC	28	Up to 24 SFP	Up to 24 SFP	4	Up to 2 SFP (2 Combo)	-	-40 to 85° C
EL228-DO-1 *	Managed	Single 18-75 VDC	28	Up to 24 SFP	Up to 24 SFP	4	Up to 2 SFP (2 Combo)	-	-40 to 85° C
EL228-DD-1 *	Managed	Dual 18-75 VDC	28	Up to 24 SFP	Up to 24 SFP	4	Up to 2 SFP (2 Combo)	-	-40 to 85° C
EL326-DO-1 *	Managed	Single 18-59 VDC	26	-	-	24	Up to 4 SFP (4 Combo)	Up to 2	-35 to 75° C
EL326-DD-1 *	Managed	Dual 18-59 VDC	26	-	-	24	Up to 4 SFP (4 Combo)	Up to 2	-35 to 75° C
EL326-AO-1 *	Managed	Single 85-264 VAC or 90-300 VDC	26	-	-	24	Up to 4 SFP (4 Combo)	Up to 2	-35 to 80° C
EL326-AA-1 *	Managed	Daul 85-264 VAC or 90-300 VDC	26	-	-	24	Up to 4 SFP (4 Combo)	Up to 2	-35 to 80° C

\*\* DIN rail - Metal

\* Rackmount - Metal

## ▶▶▶ Power over Ethernet (PoE)

Red Lion's industrial PoE solutions are designed to transmit power and/or data over an Ethernet network. PoE networks eliminate the need for running separate wires for power and are ideal in installation devices such as IP surveillance cameras, wireless access points, IP phones and other PoE-enabled devices. Our industrial PoE devices offer a compact, rugged design for harsh, remote locations.

- > Compact, rugged design
- > Switches, injectors and splitters
- > Transmit power and data over Ethernet networks



### Sixnet Series PoE Switches, Injectors and Splitters

PART NUMBER	TYPE	TOTAL PORTS	FAST ETHERNET		GIGABIT ETHERNET		MOUNTING & CASE	OPERATING TEMP
			10 / 100	100 FIBER	10 / 100/ 1000	GIG FIBER		
EB-5ES-PSE-1	Unmanaged	5	4 PoE	1	-	-	DIN rail – Metal	-40 to 75° C
SLX-5EG-1SFP	Unmanaged	5	-	-	4 PoE	1 SFP	DIN rail – Metal	-40 to 85° C
SLX-5EG-2SFP	Unmanaged	5	-	-	3 PoE	2 SFP	DIN rail – Metal	-40 to 85° C
EB-PSE-24V-1 (PoE Power Injector)	Unmanaged	2	2 (1 PoE)	-	-	-	DIN rail – Metal	-40 to 75° C
EB-PSE-48V-2 (PoE Power Injector)	Unmanaged	2	2 PoE	-	-	-	DIN rail – Metal	-40 to 75° C
EB-PD-24V-1 (PoE Splitter)	Unmanaged	2	2 (1 PoE)	-	-	-	DIN rail – Metal	-40 to 75° C

### N-Tron Series 100 PoE Switches, Injectors and Splitters

PART NUMBER	TYPE	TOTAL PORTS	FAST ETHERNET		GIGABIT ETHERNET		MOUNTING & CASE	OPERATING TEMP
			10 / 100	100 FIBER	10 / 100/ 1000	GIG FIBER		
105TX-POE	Unmanaged	5	5 (4 PoE)	-	-	-	DIN rail – Metal	-40 to 85° C
100-POE4 (PoE Injector)	Unmanaged	4	4 PoE	-	-	-	DIN rail – Metal	-40 to 85° C
105FX-POE	Unmanaged	5	4 PoE	1 SFP	-	-	DIN rail – Metal	-40 to 85° C
100-POE-SPL (PoE Splitter)	Unmanaged	2	1 (1 PoE)	-	-	-	DIN rail – Metal	-40 to 85° C

## ▶▶▶ IP67 Industrial Switches

Ideally suited for mission critical data acquisition, transportation and security applications, Red Lion's N-Tron and Sixnet IP67 industrial switches are designed to meet or exceed rugged operating conditions. Industrially hardened IP67-rated metal enclosures protect against dust and temporary water immersion while supporting extended temperature ratings, shock and vibration specs. Add in redundant power inputs and high MTBF and our IP67 switches reliably withstand extreme environments without sacrificing performance.

- > Rugged industrial design
- > IP67 Ingress protection against dust and temporary immersion up to 1 m
- > Durable M12 connectors



### N-Tron & Sixnet Series IP67 Industrial Switches

PART NUMBER	TYPE	POWER OPTIONS	TOTAL PORTS	FAST ETHERNET		GIGABIT ETHERNET		INGRESS PROTECT	OPERATING TEMP
				10 / 100	100 FIBER	GIGABIT	10 GIGABIT		
716M12	L2 Managed	10-30 VDC	16	16	-	-	-	IP67	-40 to 80° C
716M12-HV	L2 Managed	40-160 VDC	16	16	-	-	-	IP67	-40 to 80° C
708M12	L2 Managed	10-30 VDC	8	8	-	-	-	IP67	-40 to 80° C
708M12-HV	L2 Managed	40-160 VDC	8	8	-	-	-	IP67	-40 to 80° C
105M12	Unmanaged	10-30 VDC	5	5	-	-	-	IP67	-40 to 80° C
108M12	Unmanaged	10-30 VDC	8	8	-	-	-	IP67	-40 to 70° C
108M12-HV	Unmanaged	10-60 VDC	8	8	-	-	-	IP67	-40 to 70° C
ET-5ES-IP67	Unmanaged	10-30 VDC	5	5	-	-	-	IP67	-40 to 75° C
ET-5RS-IP67	Ring	10-30 VDC	5	5	-	-	-	IP67	-40 to 75° C

# Wireless Networking

Red Lion's feature rich N-Tron and Sixnet series wireless products offer the broadest range of cellular M2M routers, Wi-Fi radios and converters on the market today. Many of these solutions take advantage of low monthly cellular rates to deliver primary or back-up connectivity for a range of industrial applications. Wireless monitoring and control provides a simple, reliable and cost-effective alternative to conventional landline or WAN connectivity solutions. Our Wi-Fi radios offer standard powerful transceivers extending network ranges well beyond that of most commercial wireless products.

- > Wi-Fi Radios
- > Cellular M2M Routers



## ▶▶▶ Wi-Fi Radios

Red Lion's family of IEEE802.11a,b,g,n hardened wireless products provide a powerful solution for industrial applications. Data bandwidths up to 300 Mb/s can be attained using the 802.11n MIMO wireless technology. Our wireless radios offer standard powerful transceivers extending network ranges well beyond that of most commercial wireless products.

- > IEEE 802.11a,b,g,n compliant
- > Support data bandwidths up to 300Mb/s
- > Configurable as: Wireless Station, Station WDS, Access Point, Access Point WDS
- > Operate in bridge or router mode



### N-Tron Series 702 Wi-Fi Radios

PART NUMBER	TYPE	TOTAL PORTS	FAST ETHERNET		GIGABIT ETHERNET		INGRESS PROTECT	MOUNTING & CASE	OPERATING TEMP
			10 / 100	100 FIBER	10 / 100/ 1000	GIG FIBER			
702-W	Managed	1	1	-	-	-	IP30	DIN rail – Metal	-40 to 80° C
702M12-W	Managed	1	1 M12	-	-	-	IP67	DIN rail – Metal	-40 to 80° C

## ▶▶▶ Cellular M2M Routers

With a feature-rich suite of industrial wireless products, Red Lion offers the broadest range of M2M routers available on the market today. These solutions take advantage of low monthly cellular rates to provide remote site monitoring for a range of industrial applications. Wireless monitoring and control provides

a simple, reliable and cost-effective alternative to conventional land line or WAN connectivity solutions. Additionally, standards-based, enterprise-class functionality enables secure, reliable cellular data access, anywhere, anytime.



### Sixnet Series IndustrialPro® 6000 Cellular M2M Routers

Red Lion's IndustrialPro® routers offer a cost-effective wireless alternative for secure network communication. The rugged IndustrialPro series is ideal for harsh environments where equipment wiring space is limited. Ethernet and serial interfaces provide easy wireless communication between SCADA servers and remote RTUs, PLC/controllers and other automation devices. Additionally, support for 4G LTE with 3G fall back, provides streaming video support for monitoring applications. Convenient VPN capabilities, data encryption and stateful firewall configuration can be used to secure remote networks.

- > Uninterrupted, cost-effective communications for remote sites
- > Rugged, compact design
- > Local web-based management and administration
- > Fully configurable router and firewall



PART NUMBER	PRODUCT LINE	SERIAL RS232	ETHERNET 10/100	CELLULAR	POWER CONNECTOR	SUPPORTED CARRIERS
SN-6600-(Carrier Code)	IndustrialPro	1	1	3G / CDMA	Molex end connector cable	Carrier Codes: (SP) Sprint; (VZ) Verizon
SN-6600-(Carrier Code)-AC	IndustrialPro	1	1	3G / CDMA	AC adaptor	
SN-6600-(Carrier Code)-MX	IndustrialPro	1	1	3G / CDMA	AC adaptor w/ Molex end connector	
SN-6601-(Carrier Code)	IndustrialPro	1	1	3G / CDMA	DC powered	
SN-6601-(Carrier Code)-AC	IndustrialPro	1	1	3G / CDMA	AC adaptor	
SN-6601EB-(Carrier Code)	IndustrialPro	1	1	3G / CDMA	PoE	
SN-6621-(Carrier Code)	IndustrialPro	1	5	3G / CDMA	DC powered	
SN-6621-(Carrier Code)-AC	IndustrialPro	1	5	3G / CDMA	AC adaptor	

PART NUMBER	PRODUCT LINE	SERIAL RS232	ETHERNET 10/100	CELLULAR	POWER CONNECTOR	SUPPORTED CARRIERS	
SN-6700-(Carrier Code)	IndustrialPro	1	1	4G LTE	Molex end connector cable	Carrier Codes: (AT) AT&T; (BM) Bell Mobility; (VZ) Verizon; upcoming support from other 4G LTE carriers	
SN-6700-(Carrier Code)-AC	IndustrialPro	1	1	4G LTE	AC adaptor		
SN-6700-(Carrier Code)-MX	IndustrialPro	1	1	4G LTE	AC adaptor w/ Molex end connector		
SN-6701-(Carrier Code)	IndustrialPro	1	1	4G LTE	DC powered		
SN-6701EB-(Carrier Code)	IndustrialPro	1	1	4G LTE	PoE		
SN-6721-(Carrier Code)	IndustrialPro	1	5	4G LTE	DC powered		
SN-6721-(Carrier Code)-AC	IndustrialPro	1	5	4G LTE	AC adaptor		
SN-6800-(Carrier Code)	IndustrialPro	1	1	3G / GSM	Molex end connector cable		Carrier Codes: (AT) AT&T; (BM) Bell Mobility; (TE) TELUS; (GE) Rogers and other HSPA carriers, T-Mobile (2G only)
SN-6800-(Carrier Code)-AC	IndustrialPro	1	1	3G / GSM	AC adaptor		
SN-6800-(Carrier Code)-MX	IndustrialPro	1	1	3G / GSM	AC adaptor w/Molex end connector		
SN-6801-(Carrier Code)	IndustrialPro	1	1	3G / GSM	DC powered		
SN-6801EB-(Carrier Code)	IndustrialPro	1	1	3G / GSM	PoE		
SN-6821-(Carrier Code)	IndustrialPro	1	5	3G / GSM	DC powered		
SN-6821-(Carrier Code)-AC	IndustrialPro	1	5	3G / GSM	AC adaptor		

### Sixnet Series RAM® 6000 Cellular RTU Routers

Red Lion RAM® 6000 industrial cellular RTU routers provide a flexible platform to remotely connect, monitor and control assets across industries including utilities, oil, gas and water/wastewater. By seamlessly connecting to existing Modbus or DNP3 enabled RTU routers, PLCs and other remote equipment, our industrial cellular RTU routers provide instant access to data from pumps, valves, reclosers, transformer capacitor banks and meters. The I/O concentrator feature enables users to locally collect sensor data to optimize bandwidth.

- > Secure, reliable Modbus communication for remote sites
- > Supports 4G LTE with fall back to 3G and 2G
- > Real-time access to mission-critical data through built-in Modbus gateway
- > Simplified deployment and configuration with single web-base GUI



PART NUMBER	PRODUCT LINE	SERIAL RS232	ETHERNET 10/100	CELLULAR	POWER CONNECTOR	SUPPORTED CARRIERS	
RAM-6600-(Carrier Code)	RAM	1	1	3G / CDMA	Molex end connector cable	Carrier Codes: (SP) Sprint; (VZ) Verizon	
RAM-6600-(Carrier Code)-AC	RAM	1	1	3G / CDMA	AC adaptor		
RAM-6600-(Carrier Code)-MX	RAM	1	1	3G / CDMA	AC adaptor/Molex end connector		
RAM-6601-(Carrier Code)	RAM	1	1	3G / CDMA	DC powered		
RAM-6601EB-(Carrier Code)	RAM	1	1	3G / CDMA	PoE		
RAM-6621-(Carrier Code)	RAM	1	5	3G / CDMA	DC powered		
RAM-6621-(Carrier Code)-AC	RAM	1	5	3G / CDMA	AC adaptor		
RAM-6700-(Carrier Code)	RAM	1	1	4G LTE	Molex end connector cable		Carrier Codes: (AT) AT&T; (BM) Bell Mobility; (VZ) Verizon; upcoming support from other 4G LTE carriers
RAM-6700-(Carrier Code)-AC	RAM	1	1	4G LTE	AC adaptor		
RAM-6700-(Carrier Code)-MX	RAM	1	1	4G LTE	AC adaptor/Molex end connector		
RAM-6701-(Carrier Code)	RAM	1	1	4G LTE	DC powered		
RAM-6701EB-(Carrier Code)	RAM	1	1	4G LTE	PoE		
RAM-6721-(Carrier Code)	RAM	1	5	4G LTE	DC powered		
RAM-6721-(Carrier Code)-AC	RAM	1	5	4G LTE	AC adaptor		
RAM-6800-(Carrier Code)	RAM	1	1	3G / GSM	Molex end connector cable	Carrier Codes: (AT) AT&T; (BM) Bell Mobility; (TE) TELUS; (GE) Rogers and other HSPA carriers, T-Mobile (2G only)	
RAM-6800-(Carrier Code)-AC	RAM	1	1	3G / GSM	AC adaptor		
RAM-6800-(Carrier Code)-MX	RAM	1	1	3G / GSM	AC adaptor/Molex end connector		
RAM-6801-(Carrier Code)	RAM	1	1	3G / GSM	DC powered		
RAM-6801EB-(Carrier Code)	RAM	1	1	3G / GSM	PoE		
RAM-6821-(Carrier Code)	RAM	1	5	3G / GSM	DC powered		
RAM-6821-(Carrier Code)-AC	RAM	1	5	3G / GSM	AC adaptor		

# Communication Converters

Red Lion's suite of Media and Protocol converters are designed to bridge connectivity between diverse media types as well as legacy and Ethernet networks. Providing fast performance and rugged operating specifications, the series includes remote access servers, serial-to-fiber converters, isolators, repeaters, serial to Ethernet converters, along with Ethernet media converters.

- > Protocol Converters
- > Serial Converters
- > Media Converters



## N-Tron Series SER & ESERV Serial Converter

- > Extended environmental specifications
- > Data rates up to 115.2Kbps (SER), 230.4Kbps (ESERV)
- > Hardened DIN rail enclosure



PART NUMBER	TYPE	RS232 PORT	RS422/485	SERIAL FIBER	10/100	OPERATING TEMP
SER-485-FXC	Serial to multimode fiber converter	1 - either RS232 or RS422/485 - Terminal Block	-	1	-	-40 to 80° C
SER-485-IC	Isolated converter	1-DB9	1 - terminal block	-	-	-40 to 80° C
SER-485-IR	Isolated repeater	-	2 - terminal block	-	-	-40 to 80° C
ESERV-11T	Serial server – serial to Ethernet	1 - either RS232 or RS422/485 - Terminal Block	-	-	1	-34 to 80° C
ESERV-11T-ST	Serial server – serial to Ethernet	1 - either RS232 or RS422/485 - Terminal Block	-	1 multimode ST	-	-34 to 80° C
ESERV-12T	Serial server – serial to Ethernet	2 - either RS232 or RS422/485 - Terminal Block	-	1 multimode ST	1	-34 to 80° C
ESERV-12T-ST	Serial server – serial to Ethernet	2 - either RS232 or RS422/485 - Terminal Block	-	1 multimode ST	-	-34 to 80° C
ESERV-M12T	Modbus Gateway	2 - either RS232 or RS422/485 - Terminal Block	-	1 multimode ST	1	-34 to 80° C



## Sixnet Series ET Serial Converter

- > Easy to use
- > Secures data transfers
- > Saves time and money



PART NUMBER	TYPE	RS232 PORT	RS422/485	SERIAL FIBER	10/100	OPERATING TEMP
ET-DS-1	Ethernet to serial device server	1 - either RS232 or RS422/485 - RJ45	-	-	1	-34 to 74° C
ET-SDS-1	Ethernet to serial device server	1 - either RS232 or RS422/485 - RJ45	-	-	1	-34 to 74° C
ET-GT-232-1	Ethernet to serial Modbus gateway	1 - RS232 - DB9	-	-	1	-34 to 70° C
ET-GT-485-1	Ethernet to serial Modbus gateway	1 - RS485 - DB9	-	-	1	-34 to 70° C

## Sixnet Series Media Converter

- > Plug and play saves time and money
- > High performance and value
- > Slim DIN rail enclosure



PART NUMBER	TYPE	TOTAL PORTS	FAST ETHERNET		GIGABIT ETHERNET		MOUNTING & CASE	OPERATING TEMP
			10 / 100	100 FIBER	10 / 100/ 1000	GIG FIBER		
SL-2ES-2/3	Unmanaged	2	1	1	-	-	DIN rail – Lexan	-10 to 60° C
SLX-3ES-2/3	Unmanaged	3	2	1	-	-	DIN rail – Metal	-40 to 85° C
SLX-3EG-1SFP	Unmanaged	3	-	-	2	1SFP	DIN rail – Metal	-40 to 85° C

## N-Tron Series Media Converter

- > Plug and play saves time and money
- > High performance and value
- > Hardened DIN rail enclosure



PART NUMBER	TYPE	TOTAL PORTS	FAST ETHERNET		GIGABIT ETHERNET		MOUNTING & CASE	OPERATING TEMP
			10 / 100	100 FIBER	10 / 100/ 1000	GIG FIBER		
102MC	Unmanaged	2	1	1	-	-	DIN rail – Metal	-40 to 80° C
302MC	Unmanaged	2	1	1	-	-	DIN rail – Metal	-40 to 70° C
1002MC	Unmanaged	2	-	-	1	1 SFP	DIN rail – Metal	-40 to 85° C

# Networking Topologies

- > Daisy Chain Topology
- > Mesh Topology using RSTP
- > Propriety Ring Topology (N-Ring)
- > Star Topology
- > Tree Topology
- > Wireless & PoE Bridge Topology
- > N-Ring with N-Link Topology



# ▶▶▶ Daisy Chain Topology

## Advantages

- > Cost-effective solution: inexpensive to implement with minimal media (cables) and infrastructure (switches) required; unmanaged switches can be used to implement this topology

## Disadvantages

- > Not good for determinism: packets traveling along the daisy chain must pass through multiple devices
- > Multiple points of failure: if a cable is damaged or cut, not only is communication to the connected device lost, communication is lost to all devices
- > No redundancy

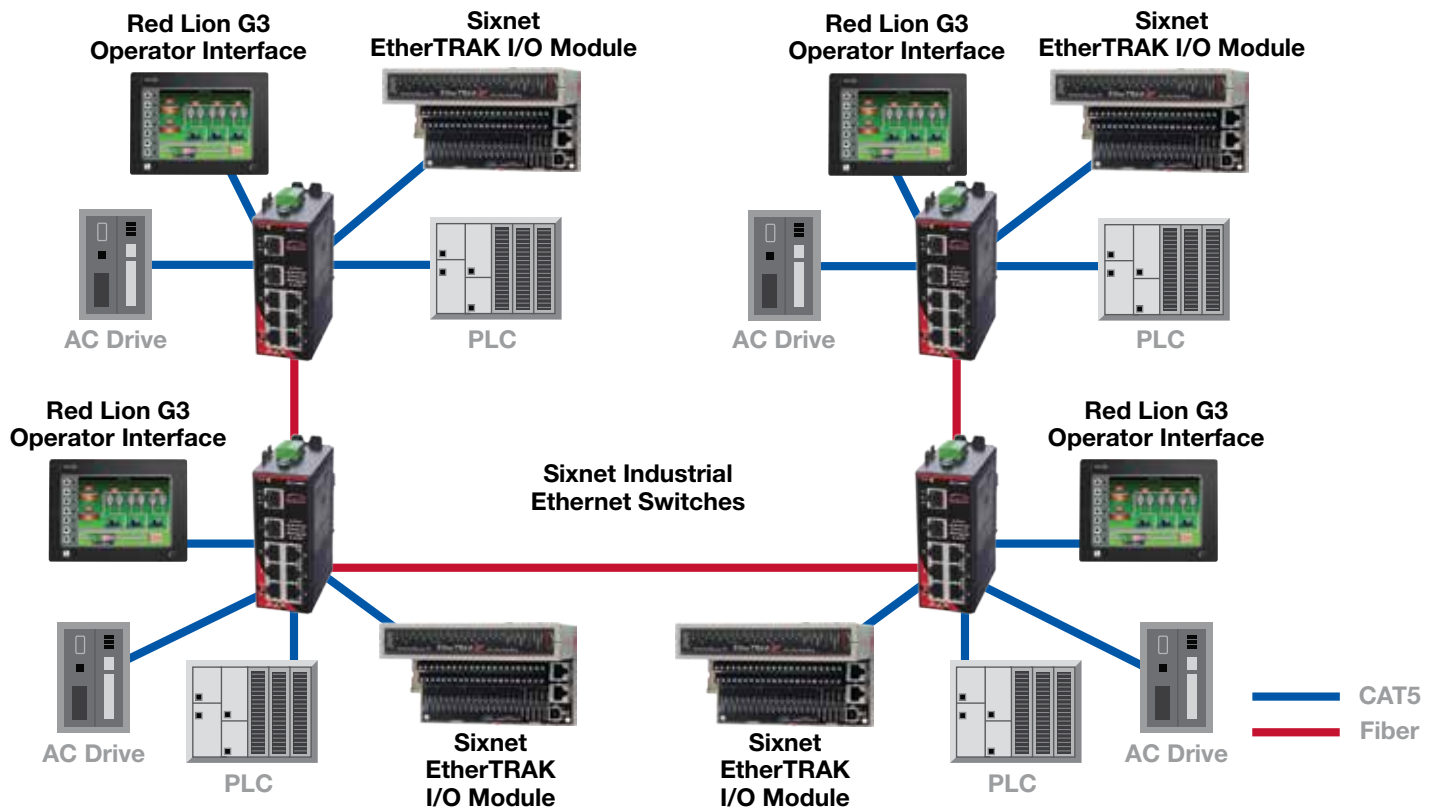

# ▶▶▶ Mesh Topology using RSTP

## Advantage

- > Redundancy: alternate, or backup, paths are available to devices
- > Industry standard: RSTP is an industry standard that has been implemented by many vendors

## Disadvantages

- > Expensive solution: requires fully managed switches that are more expensive than unmanaged switches
- > Slow recovery time: up to 5 seconds or more after a failure, which is long enough to cause PLCs and other devices to detect a network outage and fall offline

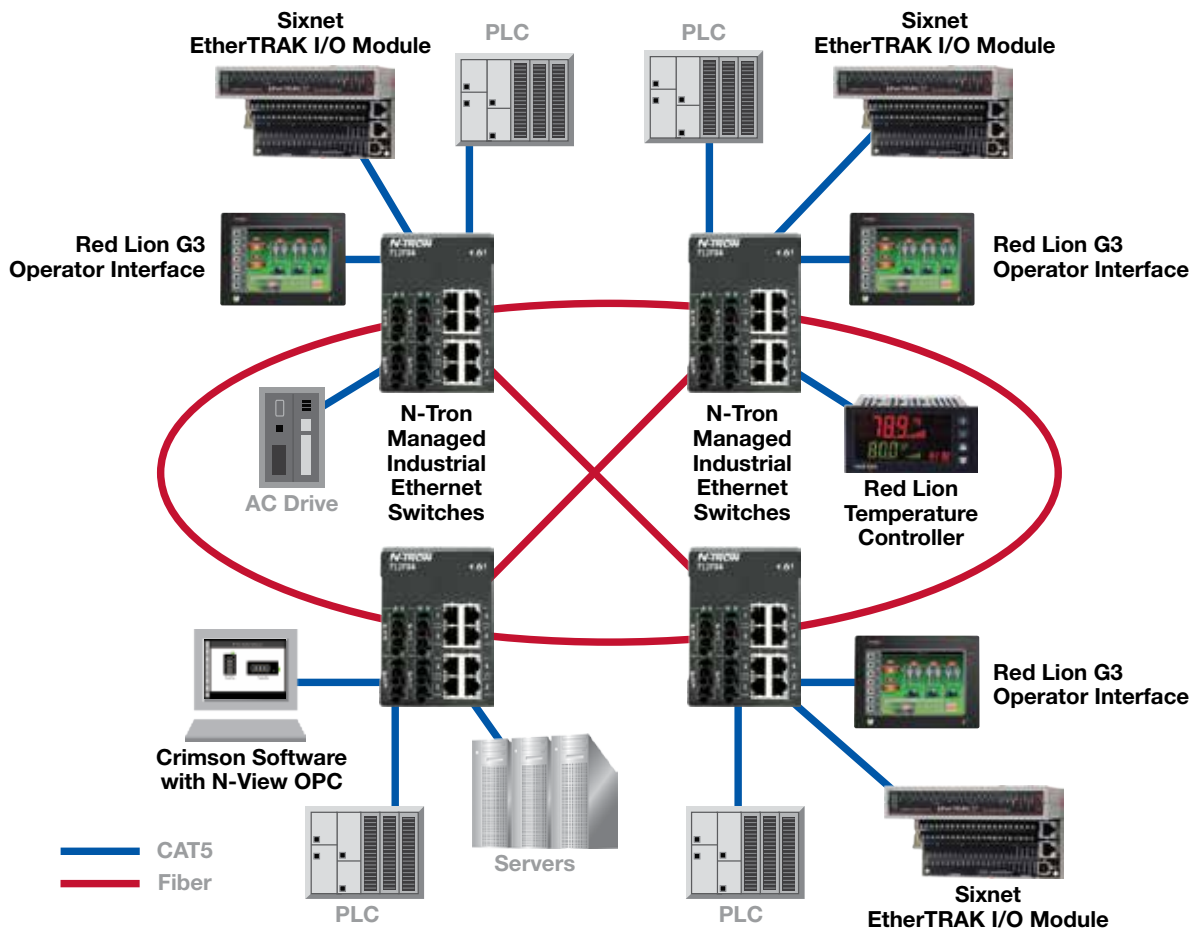

# Propriety N-Ring Topology

## Advantages

- > Redundancy: alternate, or backup, paths are available to devices
- > Fast recovery times: recovery times of ~30ms are fast enough to keep PLCs and other network devices from detecting a network failure

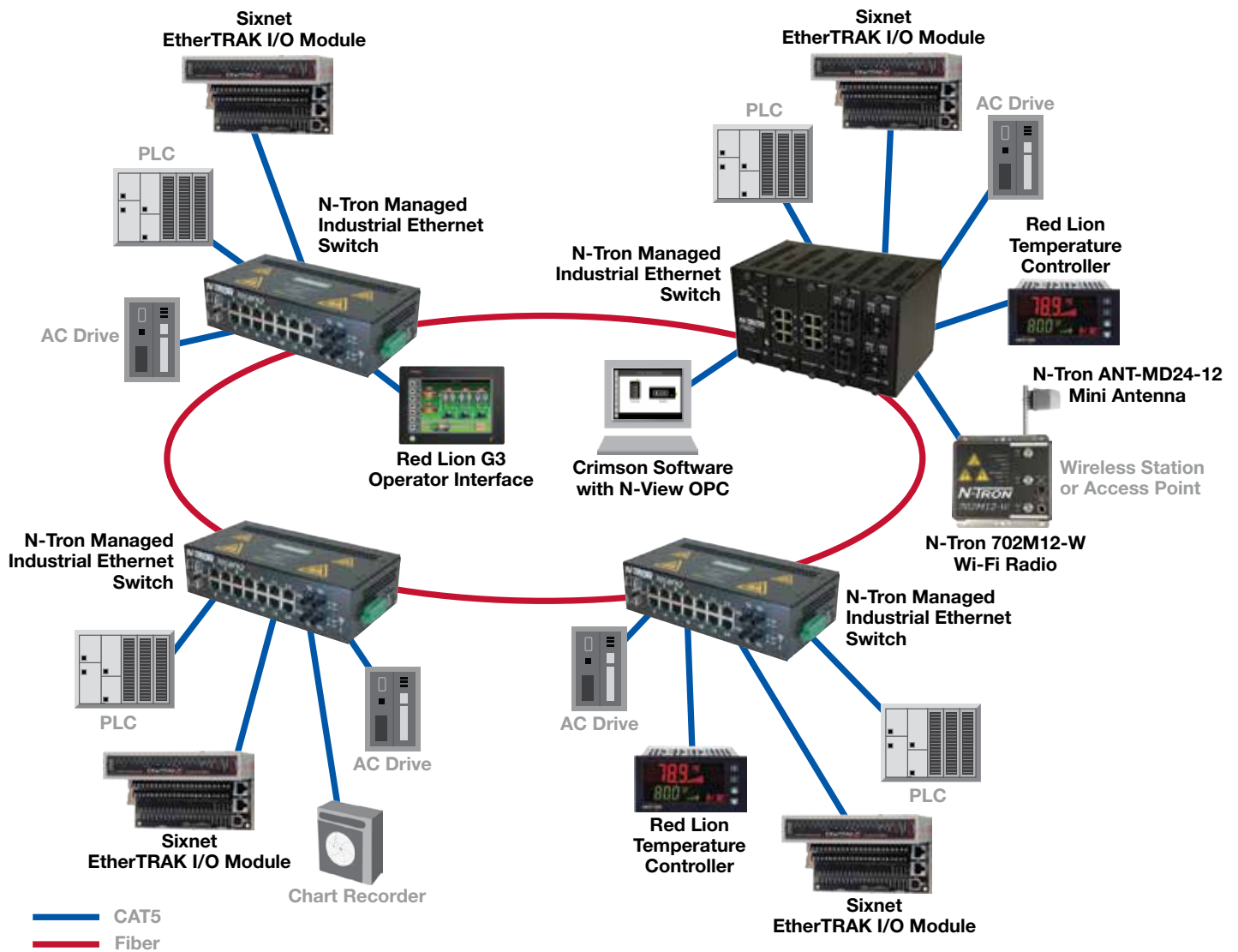

# ▶▶▶ Star Topology

## Advantages

- > Good for determinism: one hop to each device
- > Cost-effective solution: minimal media (cables) and infrastructure (switches) required; unmanaged switches can be used to implement this topology

## Disadvantages

- > Single point of failure: if a cable is damaged or cut, communication to the connected device is lost
- > No redundancy

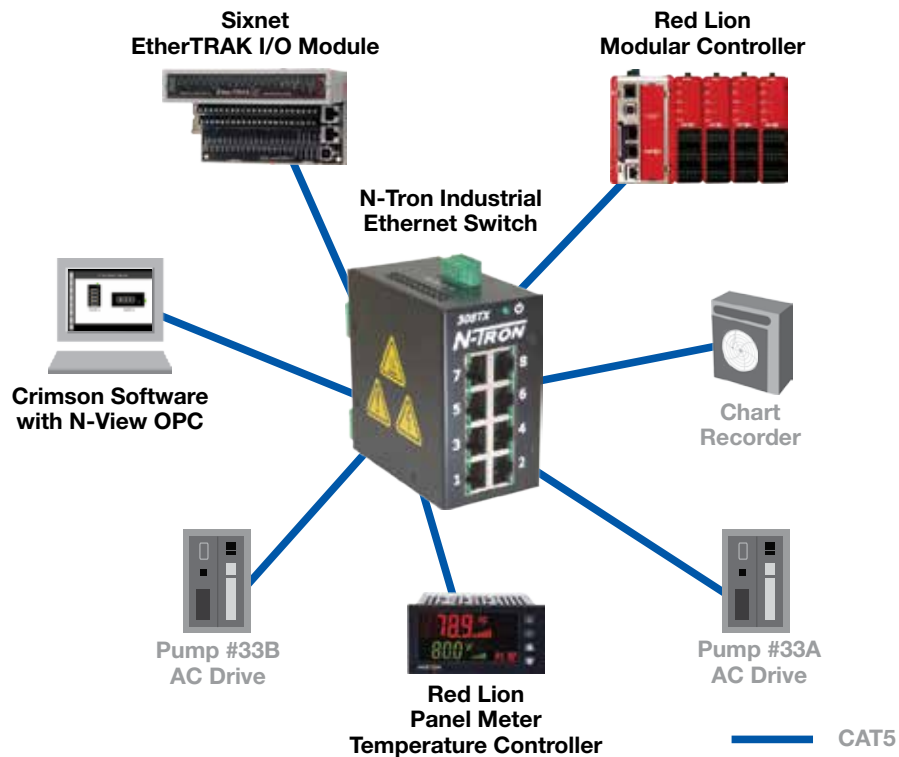

# ▶▶▶ Tree Topology

## Advantages

- > Good for determinism
- > Cost-effective solution: minimal media (cables) and infrastructure (switches) required; unmanaged switches can be used to implement this topology

## Disadvantages

- > Single point of failure: if a cable is damaged or cut, communication to the connected device is lost
- > No redundancy

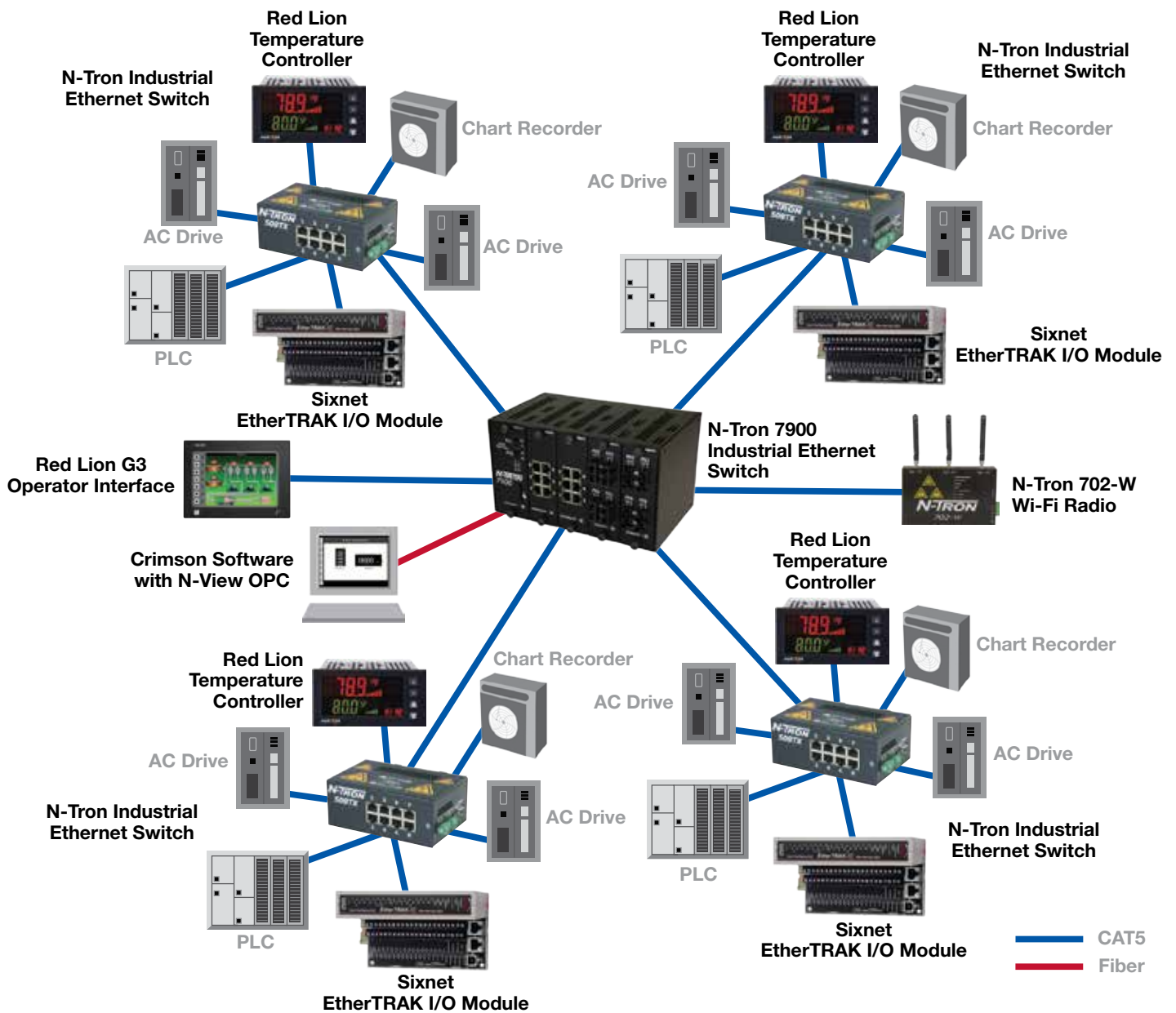

# ▶▶▶ Wireless & PoE Bridge Topology

## Advantages

- > The use of PoE switches enables devices to be powered over an Ethernet cable so it is optimal for remote sites where wiring can be costly
- > Saves money on running power and data to the same location
- > Wi-Fi provides roaming capabilities so it is optimal for sites that require mobility
- > The 702-w and 702M12-w has WDS mode functionality that would create a transparent bridge between two networks

## Disadvantages

- > Wireless is half duplex(one-way communication) so not ideal for critical control
- > Susceptible to communication interference

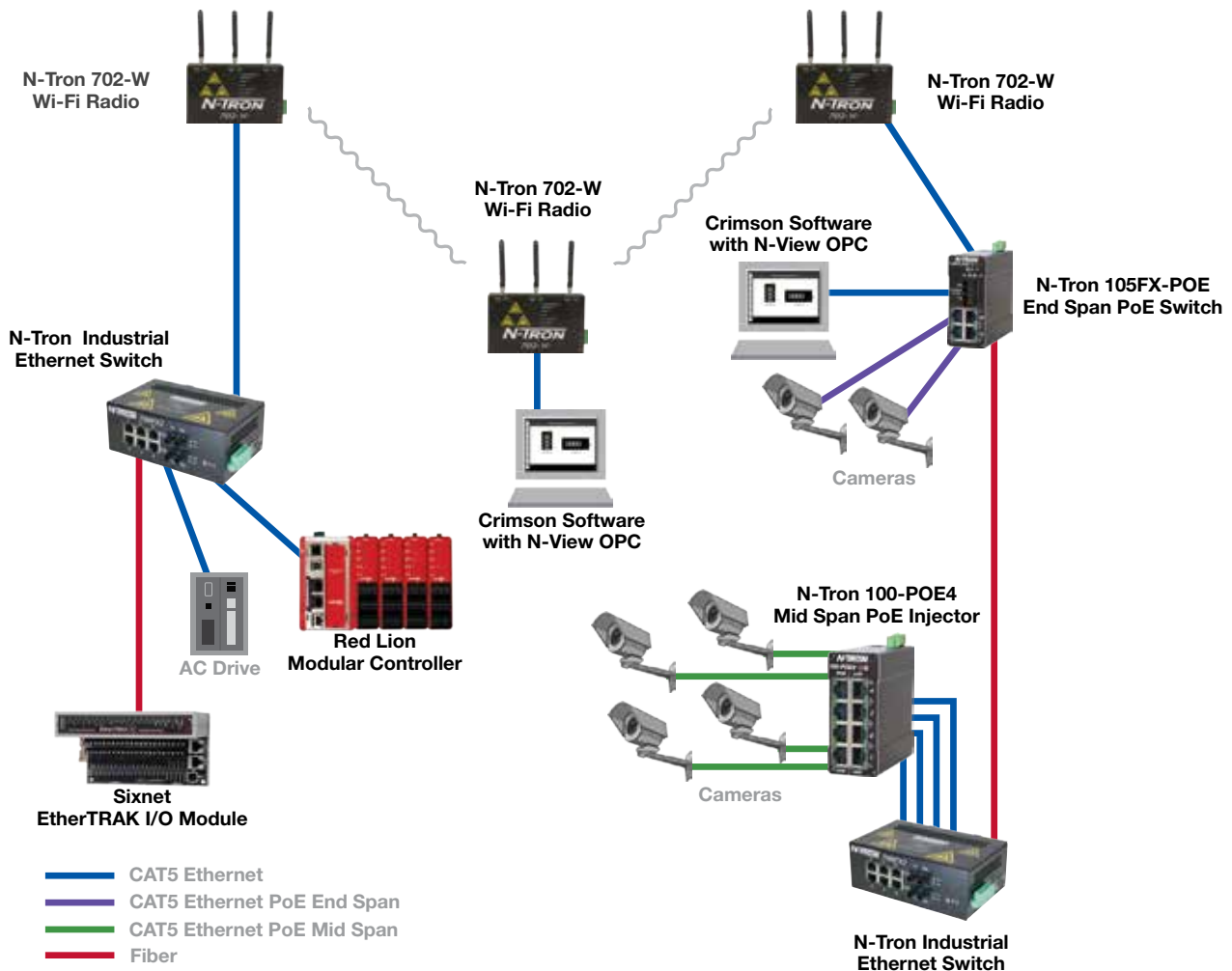



# ▶▶▶ N-Ring with N-Link Topology

## Advantages

- > Redundancy: alternate, or backup, paths are available to devices
- > Fast recovery times: recovery times of ~30ms are fast enough to keep PLCs and other network devices from detecting a network failure
- > No single point of failure

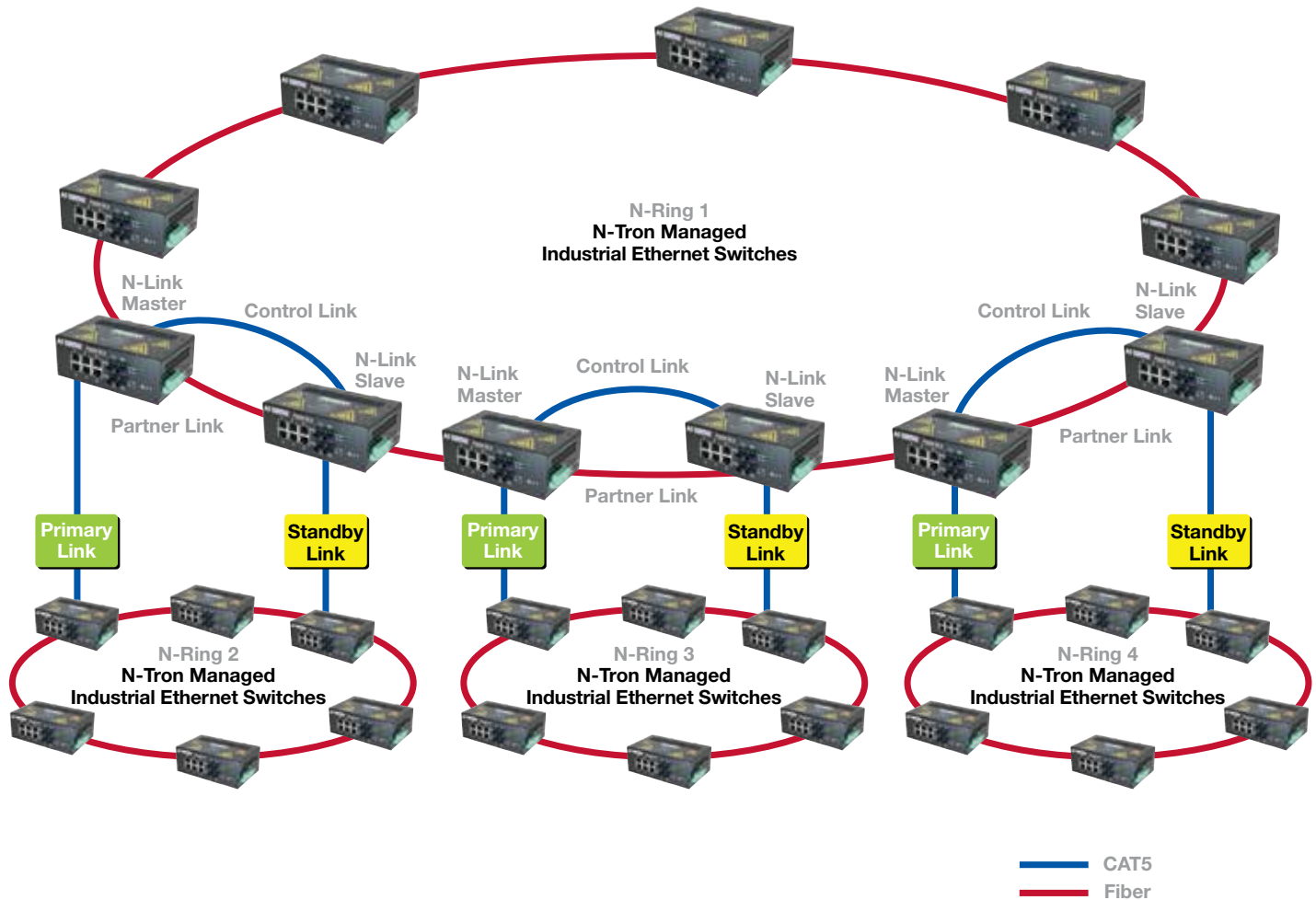

# Glossary



## Network Terms

--#--

**10Base-T** - Standard of data transmission over Cat 3, 4 or 5 twisted pair cable at 10Mbps

**100Base-TX** - Standard of data transmission over Cat5 twisted pair cable at 100Mbps

**100Base-FX** - Standard for data transmission over fiber optic cable at 100Mbps

**1000Base-LX** - Standard for data transmission over fiber optic cable at Gigabit speed and a wavelength of 1300 nm

**1000Base-SX** - Standard for transmission over fiber optic cable at Gigabit speed and a wavelength of 850 nm

-- A --

**Access Point** - A device that allows wireless devices to connect to a wired network using Wi-Fi

**Aging** - A mechanism called MAC aging that lets MAC addresses be aged out of an Ethernet switch MAC table (see ARL) after a certain period of inactivity

**Aging Time** - The length of time that a MAC address entry can remain in the ARL forwarding table. When an entry reaches its aging time, it “ages out” and is purged from the table, effectively cancelling frame forwarding to that specific port. In other words, if the switch doesn’t hear from a device after a specified period of time, the MAC entry in the ARL table is deleted.

**AP** - Access point

**Application Layer** - In the seven layer OSI model, the layer which contains all protocols and methods that fall into the realm of process-to-process communications across an Internet Protocol (IP) network

**ARL** - An internal switch table containing forwarding rules that are based upon MAC addresses

**ARP** - Address Resolution Protocol: a protocol used to resolve an IP address to a MAC address

**Auto Polarity** - Determines if the wiring polarity is correct and if not, corrects it automatically

**Auto Crossing** - The ability of a device to determine and correctly route the transmitted and received signals on twisted pair cable, eliminating the need for a crossover cable

**Auto-Negotiation** - The ability of a device to determine the data transmission rate and mode (duplex or half-duplex) and set itself accordingly

**Automatic** - IGMP Snooping - The ability of Ethernet devices to automatically set up IGMP groups, making initial configuration or replacement of devices plug and play

-- B --

**Bandwidth** - Rate of data transfer, throughput or bit rate measured in bits per seconds (bps)

**B-FOC (ST®)** - Bayonet Fiber Optic Connector or ST connector

**BPDU** - Bridge Protocol Data Unit: Data frames used by Spanning Tree protocols containing information about the switches and paths in the redundant topology

**Bridge** - Legacy Layer 2 device for connecting networks; typically replaced with Ethernet switches

**Broadcast** - A message that is transmitted to all devices on a network segment except for the device that it originated from

**Browser** - Software used to view Internet

**Bus** - Industrial communication system that connects end devices to the control system

-- C --

**CIP** - Common Industrial Protocol

**Client** - A device or software program that requests services from a server

**CSMA/CD** - Carrier Sense Multiple Access/Collision Domain: media access scheme used by Ethernet and 802.3 where devices check for a carrier signal's presence or absence in order to transmit; if two devices transmit simultaneously, a collision occurs and each device detects the collision and waits a random amount of time before a retransmission is tried

**CRC** - Cyclical Redundancy Check: a method of testing data integrity by applying an algorithm to the data in a packet and comparing it to a check digit embedded in the packet

**cUL 1604** - Underwriters Laboratories' safety standard for devices used in potentially explosive environments

**cUL 508** - Underwriters Laboratories' safety standard for Industrial equipment

**Cut Through** - A method of packet transmission in which the switch begins forwarding the frame as soon as it has read the destination address. A cut through switch will forward the data before it has completed receiving the frame. These switches function at wire speed, forwarding traffic as fast as received. Nearly all cut-through switches have no RAM buffers for storing frames. (see Store & Forward)

-- D --

**Dark Fiber** - Unused fiber optic cable

**Determinism** - Ability to predict the time that elapses between the moment a packet is sent and the moment it is received at the intended destination

**DHCP** - Dynamic Host Configuration Protocol: a method for automatically assigning IP addresses; addresses are randomly assigned from a pool and leased to devices for a specific time (leases are renewable); there is no mechanism within basic Server-Client DHCP to assure that a device on a particular port will be assigned a specific IP address

**DHCP Option 61** - A version of DHCP that assigns an IP address to a device based on the MAC address, string name or HEX value of a switch

**DHCP Option 82** - A version of DHCP that assigns an IP address to a device by using a Relay Agent; this method assures that if a device is replaced, the new device gets the same IP address

-- E --

**ESD** - Electro Static Discharge

**Ethernet** - Networking standard developed by Bob Metcalf at Xerox and standardized by the IEEE in the IEEE 802.3 standard

**Ethernet/IP** - Ethernet standard designed for industrial applications

**Ethernet Packet** - Unit of data for Ethernet transmission, containing address, tag, checksum and payload data

**Explicit Messaging** - Point-to-point communication used to exchange parameters, status and diagnostics data

-- F --

**Fast Ethernet** - IEEE 802.3 standard for transmission of data over Cat5e cable at speeds of 100Mbps

**FCC** - Federal Communications Commission

**Flow Control** - Procedure for a device to indicate that its port is being overloaded and stop the end device from transmitting data

**Frame** - A layer 2 datagram; a frame has a source and destination MAC address

**FTP** - File Transfer Protocol

**Full Duplex** - The ability to send and receive data independently and simultaneously

-- G --

**GBIC** - Gigabit Interface converter (see SFP)

**Gbps** - Gigabits per second

**GL** - Germanischer Lloyd: technical supervisory society in Germany which grants regulatory approvals for maritime industry

-- H --

**Half Duplex** - The ability to transmit and receive data, but not simultaneously

**Header** - Information in an Ethernet Packet that contains information regarding the packet size, sender and receiver address and transmission type

**HMI** - Human Machine Interface; also an industrial computer

**HTML** - HyperText Markup Language: standard web page description language

**HTTP** - HyperText Transfer Protocol : protocol by which data is exchanged between a web server and web client

**HTTPS** - HyperText Transfer Protocol Secure: protocol by which data is exchanged between a web server and web client and where each packet is encrypted

**Hub** - A device for connecting Ethernet devices that forwards data out of all ports in half duplex mode

-- I --

**IEC** - International Electrotechnical Commission

**IEEE** - Institute of Electrical and Electronics Engineers, US based association for developing standards for IT

**IGMP** - Internet Group Management Protocol: Layer 3 protocol for managing multicast traffic

**IGMP Snooping** - A Layer 2 function in which switches examine packets to determine to which group the packet should be forwarded

**IP** - Internet Protocol

**ISO** - International Standards Organization

**ISO/OSI Reference Model** - Model describing network communications; divided into seven layers of device functionality

-- L --

**LAN** - Local area network

**Latency** - The amount of time between the arrival of a data packet at a device and the forwarding of that same data to its destination

**Layer 2** - The Data Link Layer in the OSI model; function is physical addressing

**Layer 3** - The Network Layer in the OSI model; function is path determination and logical addressing

**Link Aggregation** - Method of connecting physical ports to form a virtual logical port providing redundancy and increasing throughput

**Link Status** - The condition of a connection: up (operating) or down (not operating)

**LLDP** - Link Layer Discovery Protocol: network devices use to advertise identity, capabilities and neighbors on an Ethernet network

-- M --

**MAC** - Media Access Control

**MAC Address** - A unique identifier of a network device that is hard coded and fixed; in the form of a six byte hex number where 3 bytes contain a manufacturer ID and 3 bytes contain a unique device identifier

**MAC Address Table** - In an Ethernet switch, it is a software table that associates the MAC addresses (serial numbers) of connected devices with the port to which they are connected

**Mpbs** - Megabits Per Second

**MDI-X** -Medium Dependent Interface Crossover: an Ethernet port connection that allows devices to connect to each other using a null-modem or crossover cable

**MIB** - Management Information Base: a database of objects and functions supported by a device; required for SNMP

**Modbus** - Modbus is a serial communications protocol published by Modicon in 1979 for use with programmable logic controllers (PLCs)

**Modbus Monitoring** - Ring and managed switches monitored via Modbus registers

**MSTP** - Multiple Spanning Tree Protocol: defines an extension to RSTP that allows the configuration of a separate Spanning Tree for each VLAN group

**MTBF** - Mean Time Between Failure

**Multicast** - A data packet transmitted to multiple devices (as opposed to a Unicast which is transmitted to one device or Broadcast which is transmitted to all devices)

**Multicast Address** - A logical identifier for a group of devices on a network

**Multimode** - A type of optical fiber used for communication over short distances that are usually 2km or less

-- N --

**N-Link** - Function which allows linking two N-Rings (see N-Ring)

**N-Ring** - Proprietary N-Tron network protocol that supports a ring topology with ~30ms heal time

**N-View** - OPC software that works with specially optioned

N-Tron switches to monitor network health, including unmanaged switches

**NIC** - Network Interface Card

-- O --

**ODVA** - Open Devicenet Vendors Association: promotes the use of Ethernet/IP, Devicenet and CIP for industrial applications

**OLE** - Object Linking and Embedding

**OPC** - OLE for Process Control

**OSI** - Open Systems Interconnection: open structure for networking devices which promotes interoperability between multiple vendors

**OSM** - Optical Systems Module

**OSI Model** - A model for describing communications in a network in which hardware is divided into seven layers

-- P --

**PD** - Powered Device: A device which receives electrical power via PoE from a Power Sourcing Device (PSD)

**PLC** - Programmable Logic Controller: a device used to control and monitor devices, processes and tasks in an industrial environment

**PoE** - Power Over Ethernet: a standard defined by IEEE 802.3af and IEEE 802.3at that details the transmission of power as well as data over twisted pair cable

**Polymer fiber** - Plastic fiber optic cable

**Port** - Physical interface for a cable on an Ethernet device

**Port Mirroring** - Function which copies (mirrors) the data from one port to another; typically used for troubleshooting or diagnostic purposes

**Port Security** - Functionality for preventing unauthorized access to the network; Port Security can limit the MAC addresses that can be learned on a given port

**Prioritization** - Assignment of more importance to packets based on predefined criteria and sending them before those of lesser importance

**PSD** - Power Sourcing Device: device which provides power via PoE to Powered Device (PS)

**PVID** - Port VLAN Identifier (see VLAN)

-- Q --

**QoS** - 802.1p based Quality of Service (QoS) provides traffic priority. The "threshold" is configurable from 0 to 7. When an incoming 802.1p priority tag value is greater than or equal to this number, the incoming packet will be classified as high priority. The default QoS threshold is 4.

-- R --

**Redundancy** - Ability of a network to recover from a failure or to find an alternate path for data transmission

**RJ45** - Connector commonly used on twisted pair cable for Ethernet

**RS-232** - A serial interface standard for point to point data transmission

**RS-485** - A serial interface standard for connection of up to 32 devices

**RTR** - Real-Time Ring: Proprietary Sixnet protocol that supports a ring topology; Red Lion Sixnet ring switches have this feature by default, which enables plug-and-play redundancy without configuration

**RSTP** - Rapid Spanning Tree Protocol: redundancy mechanism defined in IEEE 802.1W

**Rx** - Receive: usually seen on a fiber port to differentiate between the transmit and receive connectors

-- S --

**SCADA** - Supervisory Control And Data Acquisition: as the name suggests, is not a full control system, but rather focuses on the supervisory level. It is purely a software package that is positioned on top of hardware to which it is interfaced, in general via PLCs or other commercial hardware modules. SCADA systems are used in industrial processes such as steel making, power generation and distribution. The size of SCADA installations range from a few thousands to tens of thousands of input/output (I/O) channels.

**SFP** - Small Form Pluggable: an interface that accepts a plug-in module, offering the ability to make the port copper, multimode fiber or single-mode fiber

**Single Mode** - In a single mode fiber, the core is so small that only one path length of travel for photons is available for optical transmission. Like multimode fiber except the fiber is the same diameter as the photon allowing only one possible mode of travel.

**SNMP** - Simple Network Management Protocol: commonly used to configure or monitor the status of devices connected to a LAN; usually performed by a web browser

**Spanning Tree** - A redundancy protocol using a blocking technique that allows the building of redundant paths; not a good choice for automation environments due to a 30-90 second healing time

**SC** - Straight Connector: type of connector typically used for 100Base fiber connections

**ST** - Twist Connector: type of connector where the TX and RX are separate and usually have a twist lock mechanism

**Star Topology** - A network layout in the form of a star, with a switch in the middle and a direct run to connected devices; good for determinism, not good for redundancy

**Store and Forward** - Method in which an Ethernet switch will wait to forward a frame until entire frame is received. Most often used in environments supporting reliable physical or datalink protocols.

Frame is often checked for errors before forwarding. This type of switch is inherently slower in environments where upper layer protocols already provide reliable services. The key to identifying a store-and-forward unit is determining if switch has buffers (see Cut-Through)

**STP** - Spanning Tree Protocol: used to provide multiple paths redundant for data in the event a link is broken (see RSTP)

**STP** - Shielded twisted pair

**Subnet Mask** - Specifies which part of the IP address is used as the subnet address

**Switch** - A Layer 2 device which serves to connect devices on the network; forwards packets based on addresses unlike a hub which forwards data to all ports

-- T --

**TAG** - A field in an Ethernet Packet used to define priority or VLAN assignment

**TCP/IP** - Transmission Control Protocol/Internet Protocol: a method for insuring that data is transmitted properly

**TCP/IP Stack** - Software that defines the functions and drivers for communication via TCP/IP

**Telnet** - Terminal over Network: the protocol used to connect to other devices on the network

**TFTP** - Trivial File Transfer Protocol: a basic protocol for transferring files, often used to transmit configuration files to a device

**Transceiver** - Device with both a transmitter and a receiver that are combined and share a common circuitry or a single housing

**Trap** - SNMP event or alarm message that can be prioritized and sent to a specific address

**Trunking** - Enables multiple physical ports to be linked together and function as one uplink to a similar switch; increases bandwidth while creating a redundant connection between two switches

**Twisted Pair** - Copper cable in which the transmit/receive pairs are twisted to reduce crosstalk; Cat5e uses 4 pairs; can be shielded or unshielded

**TX** - Transmit: usually seen on a fiber port to differentiate between the transmit and receive connectors

-- U --

**Unicast** - A term used to describe communication where a piece of information is sent from one point to another point; in this case there is just one sender and one receiver; the Address Resolution Logic (ARL) table in the switch will forward this type of traffic to the destination port only and not flood traffic to all ports as a hub would

**UPS** - Uninterruptable Power Supply: allows devices to function if a main power supply is lost

**URL** - Universal Resource Locator: standardized scheme for accessing documents and services using browser software

**UTP** - Unshielded Twisted Pair: refer to definition of Twisted Pair

-- V --

**VLAN** - Virtual local area network allows users to logically subdivide a single switch to act as individual smaller switches

-- W --

**WAN** - Wide area network

**WEP** - Wired equivalent privacy: an encryption method for wireless communication, generally regarded as having been rendered ineffective

**Wi-Fi** - Wireless fidelity: a technology which certifies interoperability of wireless devices according to IEEE 802.11

**Wireshark** - A free and open source packet analyzer which can be used for network troubleshooting

**Wire Speed** - Refers to the ability to process packets at the highest speed the medium will allow

**WLAN** - Wireless LAN

**WPA** - Wi-Fi protected access: wireless security technology that utilizes dynamic key exchange

# 40<sup>+</sup> YEARS

Celebrating Innovation



Red Lion is growing. In addition to the panel meters, HMIs and other industrial automation products that Red Lion customers have always trusted, we now have a broad selection of communication technologies for industrial networks, ranging from industrial Ethernet, through Wi-Fi to complete cellular M2M solutions.

The end result? A comprehensive set of products that enable you to connect, monitor and control anything. From one device to a thousand devices. Connecting serially, via Ethernet, or over high-speed wireless networks. Speaking one protocol, or hundreds of protocols. On a single machine, across your factory, or spanning multiple sites all over the globe.



## Sensors

First product. Magnetic pickup for measuring the rate at which a shaft turns. The pickup was fed to a third-party device to display.



## Operator Panels

Paradigm Controls acquired. Adds operator panels that connect to multiple devices via serial and Ethernet connections to monitor and control operations.



## Ethernet Switches

N-Tron acquired. Adds Ethernet switches to provide integrated solutions that reach from the enterprise network to devices on the shop floor.



## Visual Management

ProductVity Station introduced. Offers a ready-to-deploy visual management system that seamlessly displays real-time KPI data and Andon messages on large TVs.

1972

1976

1996

2004

2010

2011

2012

## Counters & Meters

Counters and panel meters introduced. Gives customers a complete solution to monitor and display data within a plant or process.



## Protocol Conversion

Data Station Plus introduced. Leverages Red Lion's protocol library to enable the interconnection of different devices on wired or wireless networks.



## Layer 3 & Industrial Cellular

Sixnet acquired. Expands Ethernet switch offering, adds cellular and remote telemetry units to control and monitor complex processes in extreme conditions and remote locations.

Sixnet



A comprehensive portfolio of industrial automation and networking solutions to **connect. monitor. control.**



## Industrial Automation

### Process Control

- PID Controllers
- Data Acquisition
- RTUs & I/O Modules
- Signal Conditioners
- Sensors

### HMIs & Panel Meters

- HMI Operator Panels
- Panel Meters
- Large LED Displays
- Industrial TV Displays

## Industrial Networking

### Ethernet Switches

- Unmanaged
- Monitored
- Managed
- PoE
- Routers
- Wi-Fi Radios

### Cellular M2M

- Cellular Routers
- Cellular RTUs

### Communication Converters

- Protocol Converters
- Media Converters
- Serial Converters

As the global experts in communication, monitoring and control for industrial automation and networking, Red Lion has been delivering innovative solutions for over forty years. Our award-winning technology enables companies worldwide to gain real-time data visibility that drives productivity. Product brands include Red Lion, N-Tron and Sixnet. With headquarters in York, Pennsylvania, the company has offices across the Americas, Asia-Pacific and Europe. For more information, please visit [www.redlion.net](http://www.redlion.net). Red Lion is a Spectris company.



**Americas**  
sales@redlion.net

**Asia-Pacific**  
asia@redlion.net

**Europe, Africa  
Middle East**  
europe@redlion.net

+1 (717) 767-6511

**Connect. Monitor. Control.**

[www.redlion.net](http://www.redlion.net)