

Application Notes AC Ripple Current Calculations Solid Tantalum Capacitors

INTRODUCTION

Solid tantalum capacitors are preferred for filtering applications in small power supplies and DC/DC converters in a broad range of military, industrial and commercial systems including computers, telecommunications, instruments and controls and automotive equipment. Solid tantalum capacitors are preferred for their high reliability, long life, extended shelf life, exceptional stability with temperature and their small size. Their voltage range is 4 to 50 volts for the most common types. Tantalum chip capacitors for surface mount applications are manufactured in very small sizes and are compatible with standard pick-and-place equipment.

The electronics industry has moved to smaller and smaller power supplies and higher switching frequencies, with an increased requirement for capacitors with smaller size and operating characteristics better suited to high frequencies. This application note briefly describes the construction of solid tantalum capacitors, the concept of Equivalent Series Resistance (ESR) and presents calculations for power dissipation and voltage limitations for both low and high frequency applications.

CONSTRUCTION

The solid tantalum capacitor consists of a sintered tantalum pellet, the anode, on which a tantalum oxide dielectric is formed by electrolysis. The pellet is then coated with manganese dioxide for the cathode. Positive and negative terminations are attached to this pellet and the assembly may be conformally-coated or molded.

Looking closely at the internal structure of the pellet, we see that it is made of grains of tantalum powder sintered to each other. A solid tantalum capacitor is equivalent to many small capacitors in parallel, one for each grain of powder. This configuration produces a very large surface area, therefore a large capacitance in a relatively small volume.

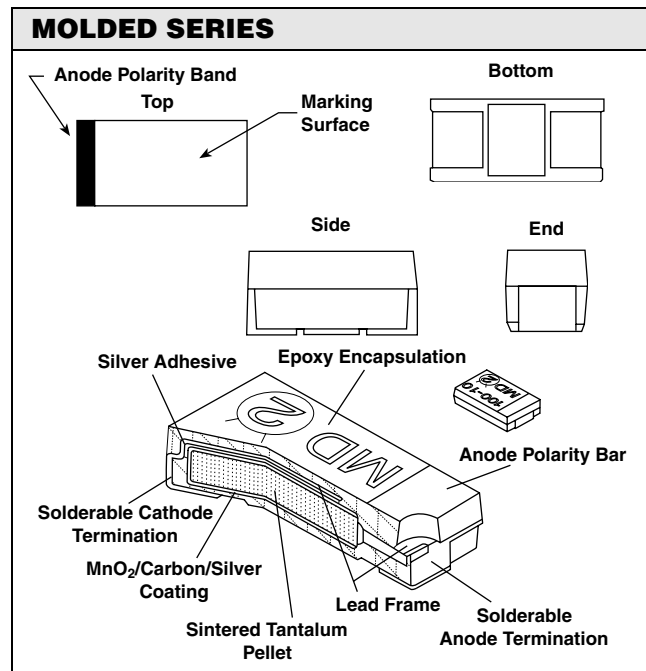
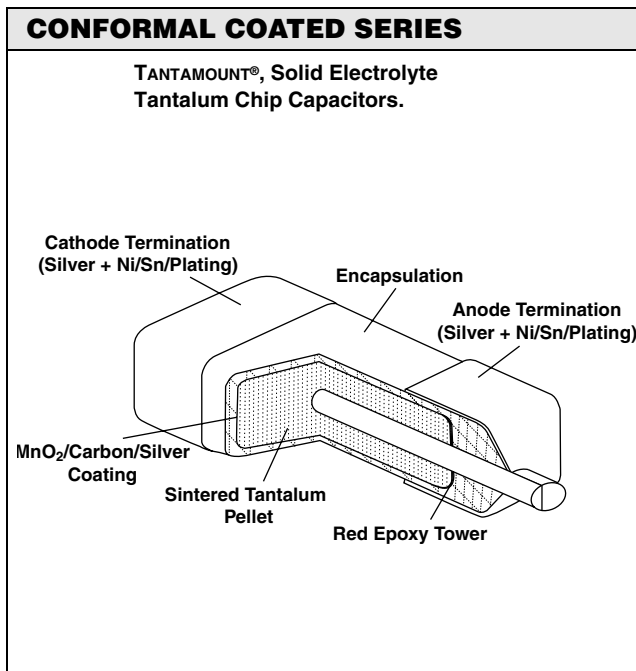
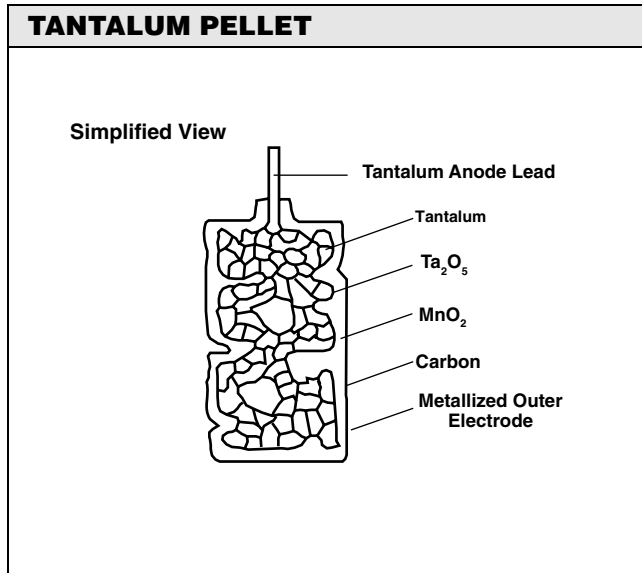



EQUIVALENT SERIES RESISTANCE (ESR)

A capacitor offers internal resistance to AC current, called the Equivalent Series Resistance (ESR). At lower frequencies, this is mainly the resistance of the dielectric. At higher frequencies, the resistance of the manganese dioxide in the voids between the grains is predominant. Because the resistivity of manganese dioxide is inversely proportional to temperature, the ESR of solid tantalum capacitors at high frequencies decreases as temperature increases.

POWER DISSIPATION LIMITATION

When AC current is applied to a solid tantalum capacitor, the resistance (ESR) that opposes the flow of current results in heat generation, according to the formula:

$$(1) P = I^2 \times ESR$$

The power (P) dissipated in the capacitor results in an elevation of temperature. The allowable temperature rise of a capacitor due to power dissipation is determined by experience. For example, this value is + 20 °C maximum for molded chip capacitors. This in turn limits the power that the capacitor can dissipate.

VOLTAGE LIMITATION

The power a capacitor can dissipate is also limited by the applied DC voltage. The operating voltage should not be allowed to rise above the rated voltage (nor should it drop below zero, since the solid tantalum capacitor is a polarized component). Assuming the capacitor is biased at half the rated voltage, which is the optimum use condition, the limiting value of the voltage is, for a sinusoidal waveform:

$$(2) V_{rms} = V_{pp}/2\sqrt{2} = R_v/2\sqrt{2}$$

Vrms for each value of Rv (Rated voltage) are:

RATED VOLTAGE	Vrms MAXIMUM
4	1.42
10	5.30
20	7.07
25	8.84
35	12.37
40	14.14
50	17.68

CURRENT LIMITATION (LOW FREQUENCY)

To find the limiting current Irms, we divide Vrms by the impedance at the desired frequency.

$$(3) I_{rms} = V_{rms}/Z$$

using the formula:

$$(4) Z = \sqrt{X^2 + ESR^2}$$

where X is $1/Cw + Lw$ ($w = 2\pi f$)

Since inductance of a solid tantalum capacitor is usually in the nanohenry range, the Lw factor becomes important only when the frequency is higher than a few megahertz. For filtering applications at 100 kHz and lower, the inductance factor will generally be ignored in the calculation. At 120 Hz, the impedance can be determined by calculation.

$$(5) Z = \sqrt{(1/2\pi fC)^2 + (DF/2\pi fC)^2} = (1/2\pi fC)\sqrt{(1 + DF^2)}$$

At 120 Hz, DF² is relatively small compared with 1 and the formula can be simplified to:

$$(6) Z = 1/2\pi fC$$

More generally, DF values of less than 10 % will not affect the final result by more than 1 %. It is important to use the lowest value for C, including the capacitance tolerance. At 120 Hz, the formula can be simplified to:

$$(7) I_{rms} = 0.266 \times CV$$

where Irms is the maximum permissible rms current in milliamperes, C the capacitance minus the capacitance tolerance in microfarads and V the rated voltage in volts. All above calculations assume the capacitor is properly biased at half the rated voltage. If this is not the case, Vrms becomes

$$(8) V_p/\sqrt{2}$$

where $V_p = V_{rated} - V_{bias}$ or V_{bias} , whichever is lower.

AC Ripple Current Calculations

Vishay Sprague

Application Notes AC Ripple Current
Calculations Solid Tantalum Capacitors



CURRENT LIMITATION (HIGH FREQUENCY)

At frequencies in the 10 kHz to several hundred kilohertz range, the power dissipation becomes the limiting factor. The following formula gives the maximum permissible ripple current for a sinusoidal wave form:

$$(9) I_{rms} = \sqrt{P_{max}/ESR}$$

P_{max} is the maximum power dissipation the capacitor can tolerate. The ESR value in the formula is the maximum ESR of the capacitor at the required frequency. This can be determined by measuring capacitors and determining a maximum value by using the mean value and adding 3 or more standard deviations. Some manufacturers specify the maximum impedance at 100 kHz or 1 MHz. Either value may be used in ripple current calculations.

Power dissipation limits calculated for the most popular surface mount types of solid tantalum capacitors are:

Molded Case Chip (293D):

CASE SIZE	MAXIMUM POWER AT + 25 °C (WATTS)
A	0.075
B	0.085
C	0.110
D	0.150
E	0.165

ESR SCREENING

For parallel operation, the ESR spread can be minimized by screening. This reduces the risk of excess ripple current exposure to any one of the capacitors.

Some equipment will only measure impedance. An impedance limit can be calculated to insure that the ESR stays in the required range. Use the formula:

$$(10) Z_{max} = \sqrt{X_c^2 + ESR^2}$$

$$X_c = 1/C\omega$$

Impedance can be measured using an impedance meter and a fixture that is appropriate for the task. With the most sophisticated fixtures, several capacitors may be tested at the same time, reducing the test cycle time.

CORRECTIVE FACTORS

The calculations for high frequency ripple current are shown in formula (9) for a sinusoidal waveform and an ambient temperature of + 25 °C. If the waveform is not sinusoidal, the ripple current limitations may differ.

Generally speaking, the ripple current limit calculated by formula (9) can be divided by the duty cycle of the signal. If the temperature is higher than + 25 °C, the ripple current limit should also be multiplied by the factors shown:

TEMPERATURE	MULTIPLYING FACTOR
+ 85 °C	0.9
+ 125 °C	0.4

RIPPLE CURRENT/VOLTAGE CALCULATIONS EXAMPLE

As an example, we will determine the ripple voltage and power dissipation capability for a 1 μ F, \pm 20 % tolerance, 35 volt, 293D capacitor.

At 120 Hz:

$$V_{rms} = R_v/2\sqrt{2} = 12.37 \text{ volts}$$

$$\begin{aligned} I_{rms} &= V_{rms}/Z \\ &= 12.37 \times 2 \times 3.14 \times 120 \times 0.8 \times 10^{-6} \\ &= 0.007 \text{ Amp.} \end{aligned}$$

If we used

$$I_{rms} = \sqrt{P_{max}/ESR}$$

$$\begin{aligned} \text{With ESR} &= DF/2pfC \\ &= (04/2 \times 3.14 \times 120 \times 0.8 \times 10^{-6}) \\ &= 66 \text{ ohms} \end{aligned}$$

$$\begin{aligned} I_{rms} &= P_{max}/ESR = \sqrt{0.080/66} \\ &= \sqrt{0.0035} \text{ Amp} \end{aligned}$$

At 120 Hz, the voltage is the limiting factor.

At 100 kHz:

$$I_{rms} = \sqrt{P_{max}/ESR}$$

At 100 kHz, the typical ESR for a 1 μ F/35 volts tantalum is:

$$ESR = \sqrt{1.5 \text{ ohms}} (Z = 3 \text{ ohms})$$

$$I_{rms} = 0.085/1.5 = 0.238 \text{ Amp.}$$

If we now look at the maximum ripple voltage, the above limitation translates into:

$$V_{rms} = Z \times I_{rms} = 3 \times 0.231 = 0.71 \text{ volts.}$$

At 100 kHz, the power dissipation is the limiting factor.



TYPICAL CURVES OF IMPEDANCE AND ESR VS FREQUENCY

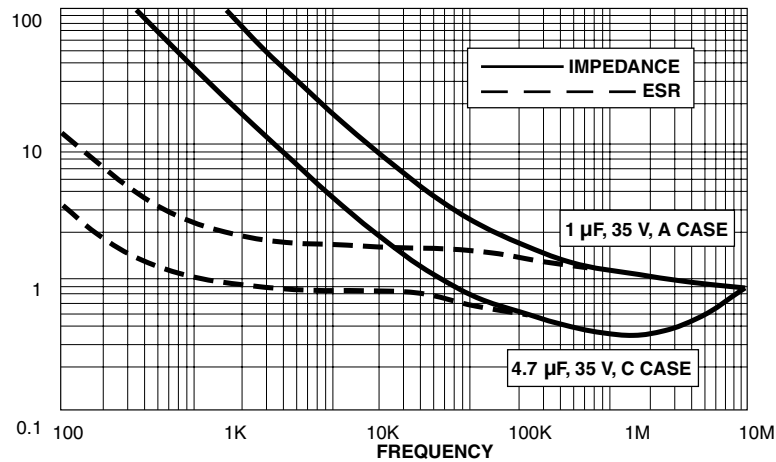

CONCLUSIONS

The industry is moving towards smaller and smaller power supplies and DC/DC converters operating at higher frequencies. The three factors shown become more and more important in capacitor selection.

1. Higher Switching Frequencies: The switching frequency of power supplies has increased from the 10 kHz range a decade ago to the 100 kHz range and up today. The ESR of solid tantalum capacitors is either the same or lower at higher frequencies and impedance is at a minimum in the 100 kHz to megahertz range. Higher switching frequencies and the need for smaller sizes will increase the use of solid tantalum capacitors.

2. Surface Mount Technology: The application of surface mount technology not only reduces the size of power supplies and converters but also uses the substrate on which the components are mounted to dissipate some of the heat generated by the switching elements. Solid tantalum chip capacitors are well suited for this application. They have superior operating characteristics, do not leak electrolyte and are compatible with common automated surface assembly equipment.

3. Tighter High Frequency Parameters: The reduction of the maximum ESR of a solid tantalum capacitor may produce tradeoffs in size or DC characteristics. Rather than looking at lower ESR in terms of process average, it may be advisable to try to reduce ESR variation, producing a lower maximum ESR with a tighter distribution. This improvement may be achieved by using statistical process control, an approach already being implemented at Vishay Sprague Solid Tantalum manufacturing facilities.