

ADN-C Series

120 - 480 Watts

Industrial

Total Power: 120 - 480 Watts
Input Voltage: 85-264 Vac
90-375 Vdc
of Outputs: Single

Special Features

- Slim form factor
- Five year warranty
- High Efficiency > 90% Typ.
- Full Power at 60 °C
- Power Boost™
- Industrial Grade Design
 - Patented metal mounting clip
 - Metal case
- MTBF > 450Khr demonstrated at 40°C 115Vac
- Active PFC > 0.92
- Adjustable output
- OVP protection with autorecovery
- Continuous short circuit and overload protection
- SEMI F47 Sag Immunity
- 3 Status LEDs
Input / Output / Alarm
- DCOK Relay
- Parallel operation capability
- Screw terminal connections
- RoHS Compliant
- No tools required for mounting

Safety

- UL 508, cULus Listed
- UL 60950-1, cURus
- IEC 60950-1
- Class I, Div 2 Hazardous Locations
- IP20
- CE



Product Descriptions

The ADN-C series has improved upon the superior reliability of the ADN Series of AC-DC power supplies with increased Mean Time Between Failure (MTBF) by reducing the part count and strategic use of high quality components. In addition to being extremely reliable by design, the ADN-C has built-in protection from over temperature, overloads and short circuits. This ensures that reliability is not compromised by operation temporarily outside of normal conditions. Intuitive visual diagnostics help ensure easy troubleshooting when such conditions occur so that equipment downtime can be minimized.

The ADN-C series features a universal 85-264 Vac input – enabling it to be used anywhere in the world – and is also capable of operating from a 90-375 Vdc input. The power supply produces a tightly regulated 24V output of up to 480W continuously with convection cooling. The main output can be adjusted over the range from 22.5V to 28.5V (24V to 28V for ADN20-24-1PM-C) over nominal factory set output voltage of 24.5V

Active power factor correction is employed to minimize input harmonic current distortion and ensure compliance with the international EN61000-3-2 standard. The power supplies have a full load ambient operating temperature range of -25 to +60 degrees Celsius without de-rating at convection cooling condition. Operation between 60 and 70 degrees Celsius, the output should be derated by 5 percent per degree.

Model Numbers

Rev.10.07.06 #2.0
ADN-C Series
Page 2

Standard	Output Voltage	Minimum Load	Maximum Load Current ($I_{O,max}$)	Maximum Load Power ($P_{O,max}$)
ADN5-24-1PM-C	24Vdc	0A	5A	120W
ADN10-24-1PM-C	24Vdc	0A	10A	240W
ADN20-24-1PM-C	24Vdc	0A	20A	480W

Options

None

Absolute Maximum Ratings

Stress in excess of those listed in the “Absolute Maximum Ratings” may cause permanent damage to the power supply. These are stress ratings only and functional operation of the unit is not implied at these or any other conditions above those given in the operational sections of this TRN. Exposure to any absolute maximum rated condition for extended periods may adversely affect the power supply’s reliability.

Table 1. Absolute Maximum Ratings:

Parameter	Model	Symbol	Min	Typ	Max	Unit
Input Voltage: AC continuous operation DC continuous operation	All models	$V_{IN,AC}$	85	-	264	Vac
	All models	$V_{IN,DC}$	90	-	375	Vdc
Maximum Output Power, continuous	ADN5-24-1PM-C	$P_{O,max}$	-	-	120	W
	ADN10-24-1PM-C		-	-	240	
	ADN20-24-1PM-C		-	-	480	
Isolation Voltage Input to outputs Input to safety ground Outputs to safety ground	All models		-	-	2500	Vdc
	All models		-	-	2500	Vdc
	All models		-	-	100	Vdc
Ambient Operating Temperature	ADN5-24-1PM-C	T_A	-10	-	+70 ^{1,2}	°C
	ADN10-24-1PM-C		-10	-	+70 ^{1,2}	
	ADN20-24-1PM-C		-25	-	+70 ^{1,2}	
Storage Temperature	ADN5-24-1PM-C	T_{STG}	-25	-	+85	°C
	ADN10-24-1PM-C		-25	-	+85	
	ADN20-24-1PM-C		-40	-	+85	
Humidity (non-condensing) Operating Non-operating	All models		5	-	90	%
	All models		0	-	95	%
Altitude Operating Non-operating	All models		0	-	10,000	feet
	All models		-1,000	-	50,000	feet

Note 1 - Derate each output at 5% per degree C from 60°C to 70°C

Note 2 - Operation up to 50% load permissible with sideways (horizontal) or front side up (top) mounting orientation

Electrical Specifications

Input Specifications

Table 2. Input Specifications:

Parameter	Conditions	Symbol	Min	Typ	Max	Unit
Operating Input Voltage, AC	All	$V_{IN,AC}$	85	115/230	264	Vac
Input AC Frequency	All	f_{IN}	43	50/60	67/400	Hz
Operating Input Voltage, DC	All	$V_{IN,DC}$	90	-	375	Vdc
Maximum steady state Input Current	ADN5 ADN10 ADN20 $V_{IN,AC} = 85V_{AC}$	$I_{IN,max}$	- -	- -	4 - 8.0	Aac
Harmonic Line Currents	All	THD	Per EN61000-3-2			
Power Factor	$I_O = I_{O,max}$ $V_{IN,AC} = 85 \text{ to } 264V_{ac}$	PF	0.92	-	-	
Startup Surge Current (Inrush) @ 25°C	ADN5 ADN10 ADN20 $V_{IN,AC} = 264V_{AC}$	$I_{IN,surge}$	- - -	- - -	15 30 40	A_{PK}
Input Fuse	ADN5 ADN10 ADN20 Internal, L line 250VAC rated MXEP type		-	-	3 5 10	A
Input AC Low Line Start-up Voltage	$I_O = I_{O,max}$	$V_{IN,AC-start}$	70	-	78	Vac
PFC Switching Frequency	All	$f_{SW,PFC}$	43	-	53	kHz
DCDC Switching Frequency	All	$f_{SW,DC-DC}$	84	-	90	kHz
Efficiency ($T_A = 25^\circ C$, forced air cooling)	ADN5 ADN10 ADN20 $V_{IN,AC} = 230V_{ac}$ $I_O = I_{O,max}$	η	- - -	90 90 92	- - -	%
Hold Up Time	$V_{IN,AC} = 100V_{ac}$ $P_O = P_{O,max}$ $T_A = 25^\circ C$	$t_{Hold-Up}$	20	-	-	mSec
Turn On Delay	Resistive Load Capacitive Load $V_{IN,AC} = 85V_{ac}$ $I_O = I_{O,max}$	$t_{Turn-On}$	- -	- -	1.0 1.5	Sec

Output Specifications

Table 3. Output Specifications:

Parameter		Condition	Symbol	Min	Typ	Max	Unit
Factory Set Voltage	All models	$I_O = 0A$	$V_{O,Factory}$	24.25	24.50	24.75	V
Output Adjust Range	ADN5 ADN10 ADN20	$I_O = 0A$	V_O	22.5 22.5 24.0	- - -	28.5 28.5 28.0	V
Line / Load Regulation	All models	$V_{IN,AC} = 85 \text{ to } 264V_{ac}$ $I_O = 0 \text{ to } I_{O,max}$	V_O	-0.5	-	+0.5	% V_O
Total Regulation	All models	Inclusive of line, load temperature change, warm-up drift	V_O	-2.0	-	+2.0	% V_O
Output Ripple, pk-pk	ADN5 ADN10 ADN20	See note 1	V_O	- - -	- - -	50 50 100	mV _{PK-PK}
Output Current, continuous	ADN5 ADN10 ADN20	See note 2 and 3	$I_{O,max}$	0 0 0	- - -	5 10 20	A
Maximum Output Power, continuous	ADN5 ADN10 ADN20			$P_{O,max}$	- - -	- - -	120 240 480
Output Current, peak	ADN5 ADN10 ADN20	$V_O \geq 20.0V$, 4 sec max	$I_{O,peak}$	7.5 15 30	- - -	- - -	A
Output Current, short circuit	All models	$V_O \leq 0.5V$, auto recovery	$I_{O,SC}$	160	-	-	% $I_{O,max}$
Dynamic Response - Peak Deviation	All models	50% to 100% of $I_{O,max}$ load change Slew rate = $1A/\mu s$ Output capacitance = $100\mu F/A$	$\pm\%V_O$	-	-	2	%
Dynamic Response - Setting Time	All models		t_s	-	-	-	mSec
Turn On Overshoot	All models	$I_O = 0$	% V_O	-	-	2	%
Over Voltage Protection		Auto recovery	V_O	30.5	-	33.0	V
Back EMF Immunity		No damage, auto recovery	V_O	-	-	35.0	V
Load Capacitance	All models	Startup	C_O	0	-	7000	μF
Over Temperature Protection		All		Auto Recovery			

Note 1 - Measure with a $0.1\mu F$ ceramic capacitor in parallel with a $10\mu F$ tantalum capacitor using a 20MHz bandwidth limited oscilloscope

Note 2 - Standard operating orientation is front side facing forward.

Note 3 - Operation up to 50% load permissible with sideways (horizontal) or front side up (top) mounting orientation

ADN5-24-1PM-C Performance Curves

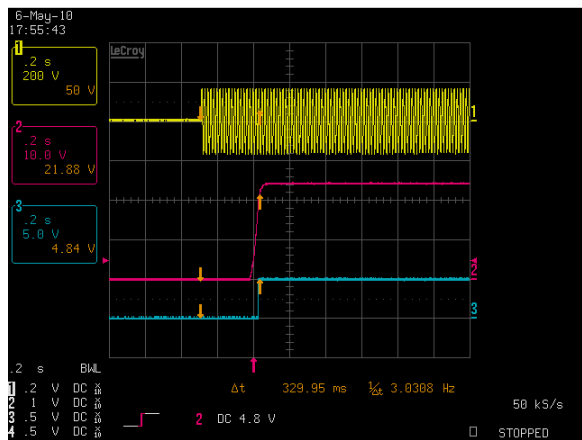

Figure 1: ADN5-24-1PM-C Turn-on delay
Vin = 115Vac Load: Io = 5.0A
Ch 1: AC Mains Ch 2: Vo Ch 3: DCOK

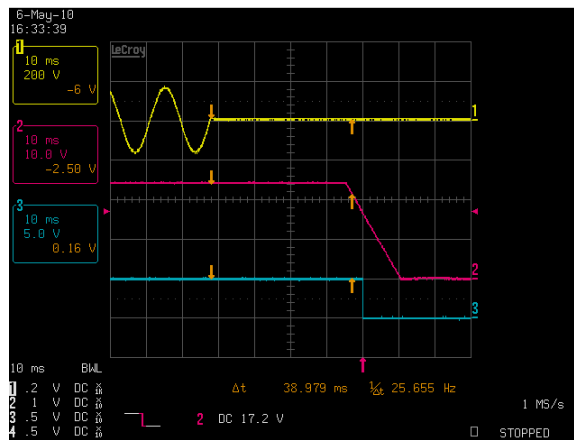

Figure 2: ADN5-24-1PM-C Hold-up Time (time to decay)
Vin = 115Vac Load: Io = 5.0A
Ch 1: AC Mains Ch 2: Vo Ch 3: DCOK

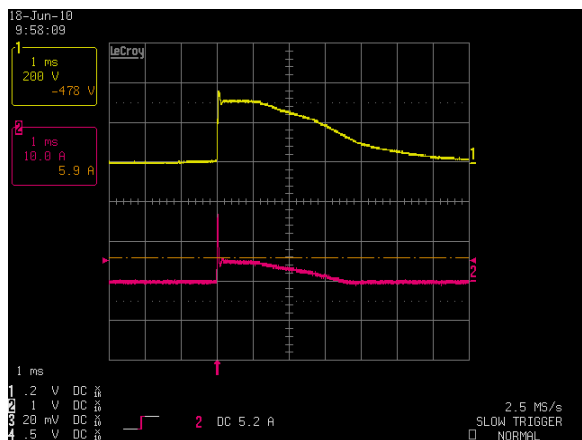

Figure 3: ADN5-24-1PM-C Inrush Current
Vin = 230Vac Load: Io = 0A, Turn on angle = 90 deg
Ch 1: AC Mains Ch 2: I_N

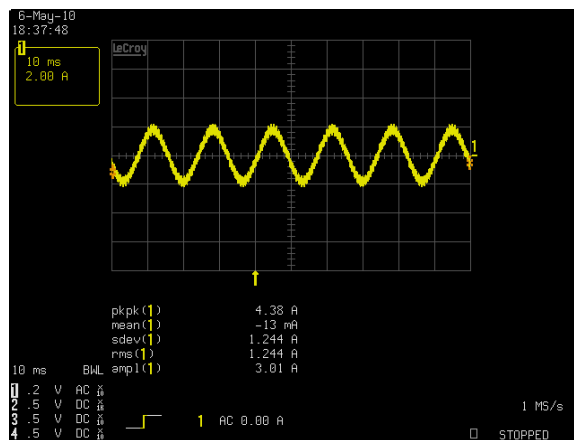

Figure 4: ADN5-24-1PM-C Input Current Waveform
Vin = 115Vac Load: Io = 5.0A
Ch 1: I_N

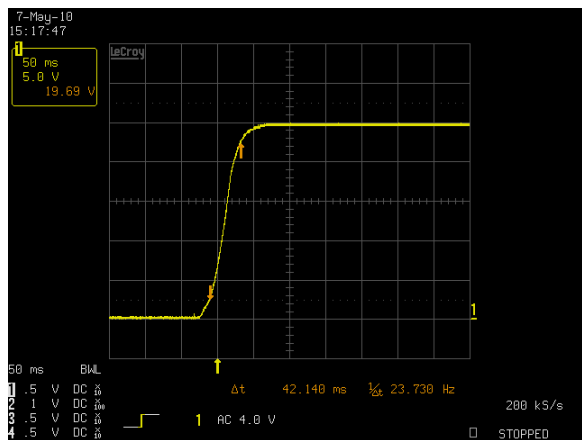

Figure 5: ADN5-24-1PM-C Output Voltage Startup Characteristic
Vin = 90Vac Load: Io = 5.0A, Output Capacitance = 330uF/A
Ch 1: Vo

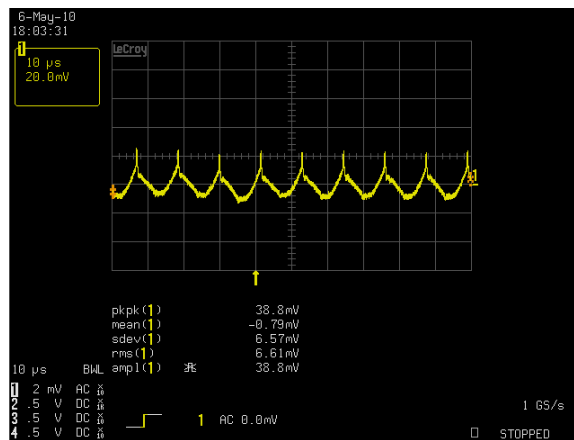

Figure 6: ADN5-24-1PM-C Ripple and Noise Measurement
Vin = 115Vac Load: Io = 5.0A
Ch 1: Vo

ADN5-24-1PM-C Performance Curves

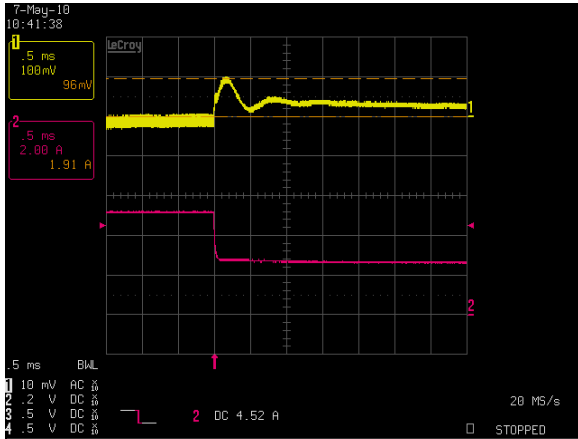

Figure 7: ADN5-24-1PM-C Transient Response – High to Low
Vin = 115Vac Load: Io = 100% to 50% load change, 1A/us slew rate
Ch 1: Vo Ch 2: Io

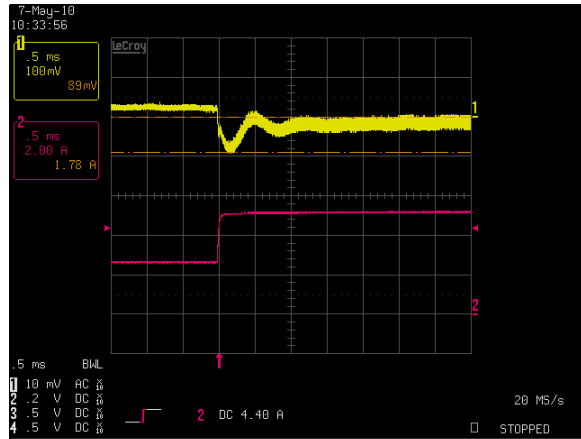

Figure 8: ADN5-24-1PM-C Transient Response – Low to High
Vin = 115Vac Load: Io = 50% to 100% load change, 1A/us slew rate
Ch 1: Vo Ch 2: Io

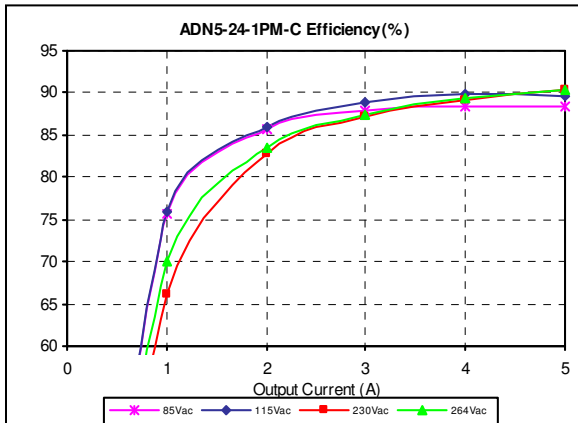

Figure 9: ADN5-24-1PM-C Efficiency Curves @ 25 °C, Convection Cool
Vin = 85 to 264Vac Load: Io = 0 to 5.0A

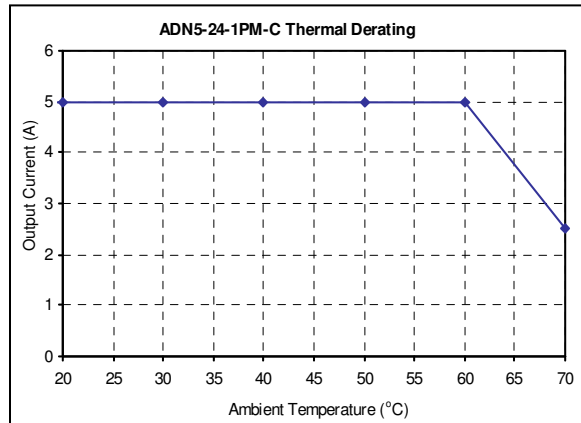

Figure 10: ADN5-24-1PM-C Derating Curves
Vin = 115Vac Load: Io = 0 to 5.0A

ADN10-24-1PM-C Performance Curves

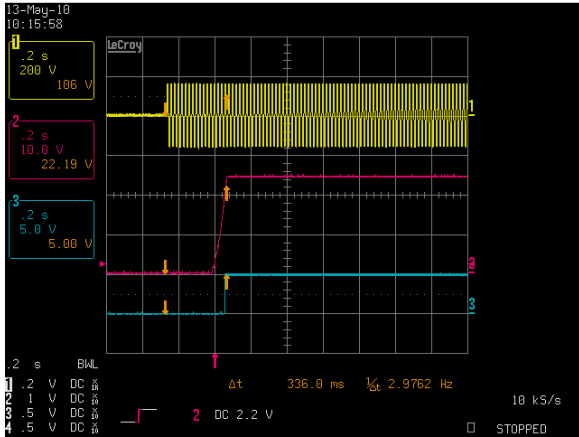

Figure 11: ADN10-24-1PM-C Turn-on delay
 Vin = 115Vac Load: Io = 10.0A
 Ch 1: AC Mains Ch 2: Vo Ch 3: DCOK

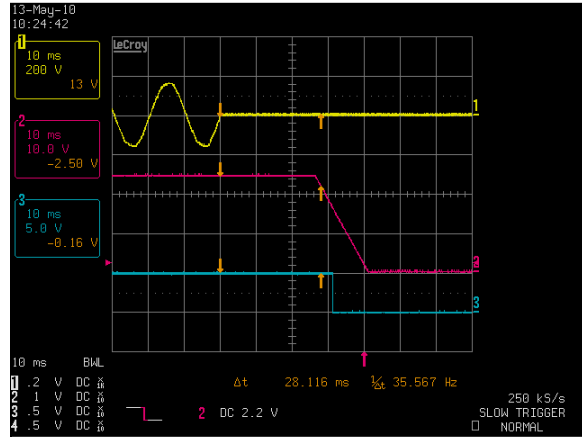

Figure 12: ADN10-24-1PM-C Hold-up Time (time to decay)
 Vin = 115Vac Load: Io = 10.0A
 Ch 1: AC Mains Ch 2: Vo Ch 3: DCOK

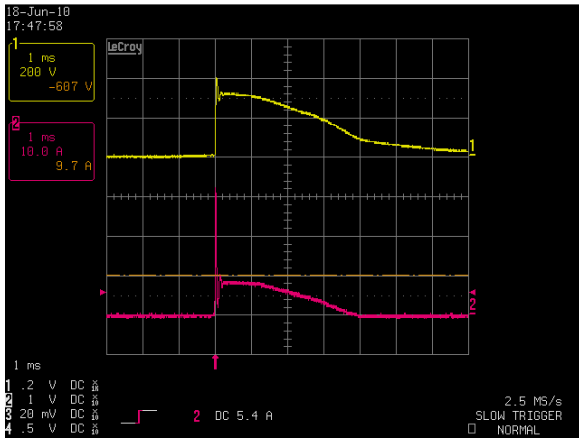

Figure 13: ADN10-24-1PM-C Inrush Current
 Vin = 230Vac Load: Io = 0A, Turn on angle = 90 deg
 Ch 1: AC Mains Ch 2: I_N

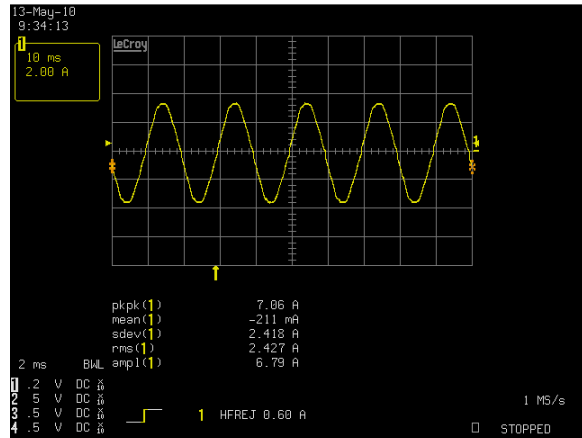

Figure 14: ADN10-24-1PM-C Input Current Waveform
 Vin = 115Vac Load: Io = 10.0A
 Ch 1: I_N

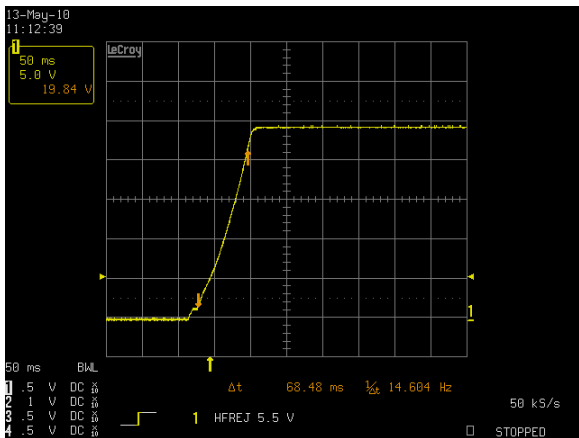

Figure 15: ADN10-24-1PM-C Output Voltage Startup Characteristic
 Vin = 90Vac Load: Io = 10.0A, Output Capacitance = 330uF/A
 Ch 1: Vo

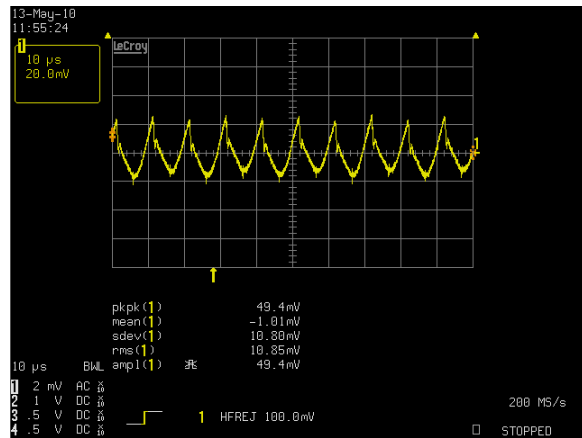

Figure 16: ADN10-24-1PM-C Ripple and Noise Measurement
 Vin = 115Vac Load: Io = 10.0A
 Ch 1: Vo

ADN10-24-1PM-C Performance Curves

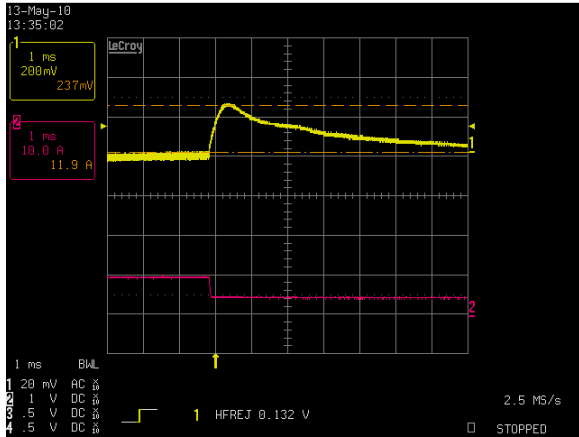

Figure 17: ADN10-24-1PM-C Transient Response – High to Low
Vin = 115Vac Load: Io = 100% to 50% load change, 1A/us slew rate
Ch 1: Vo Ch 2: Io

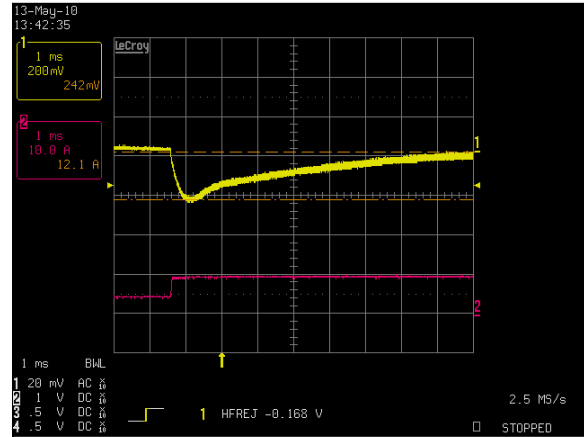

Figure 18: ADN10-24-1PM-C Transient Response – Low to High
Vin = 115Vac Load: Io = 50% to 100% load change, 1A/us slew rate
Ch 1: Vo Ch 2: Io

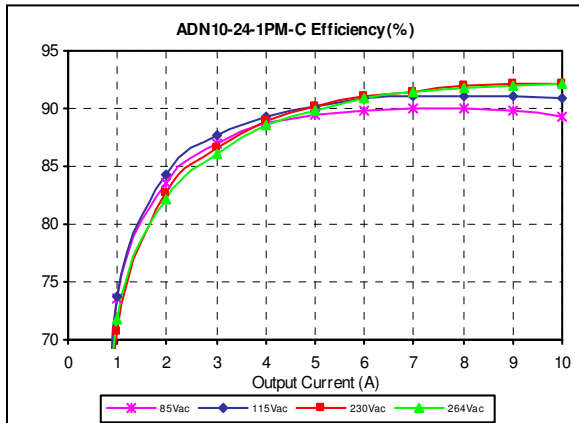

Figure 19: ADN10-24-1PM-C Efficiency Curves @ 25 °C, Convection Cool
Vin = 85 to 264Vac Load: Io = 0 to 10.0A

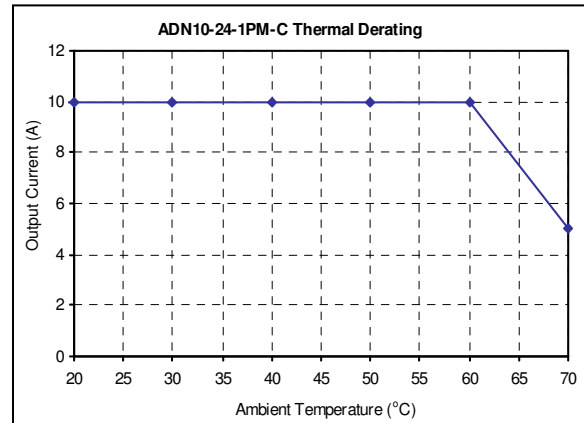

Figure 20: ADN10-24-1PM-C Derating Curves
Vin = 115Vac Load: Io = 0 to 10.0A

ADN20-24-1PM-C Performance Curves

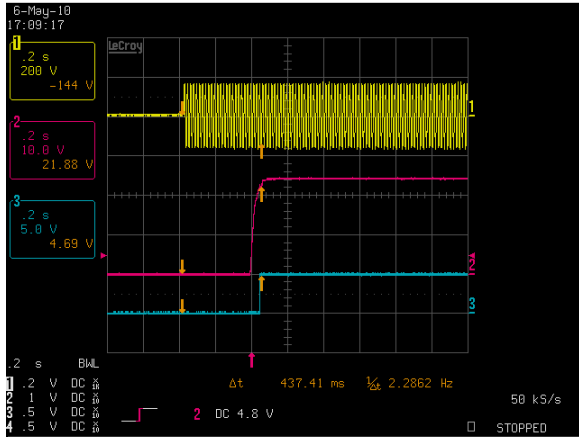

Figure 21: ADN20-24-1PM-C Turn-on delay
Vin = 115Vac Load: Io = 20.0A
Ch 1: AC Mains Ch 2: Vo Ch 3: DCOK

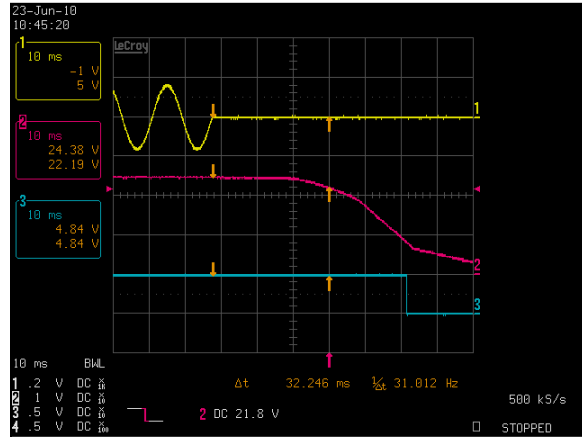

Figure 22: ADN20-24-1PM-C Hold-up Time (time to decay)
Vin = 115Vac Load: Io = 20.0A
Ch 1: AC Mains Ch 2: Vo Ch 3: DCOK

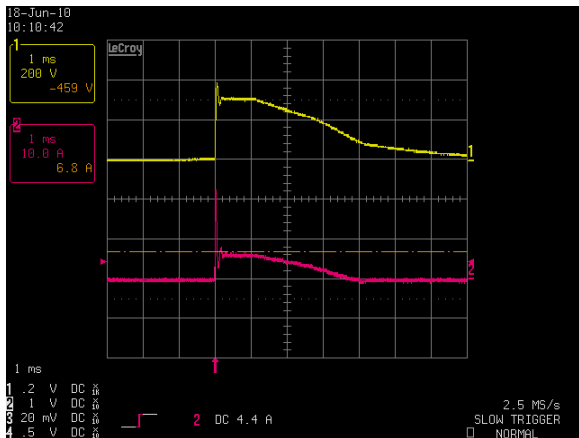

Figure 23: ADN20-24-1PM-C Inrush Current
Vin = 230Vac Load: Io = 0A, Turn on angle = 90 deg
Ch 1: AC Mains Ch 2: In

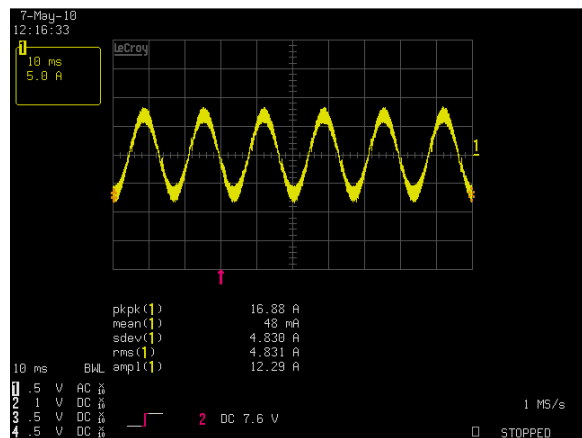

Figure 24: ADN20-24-1PM-C Input Current Waveform
Vin = 115Vac Load: Io = 20.0A
Ch 1: I_{IN}

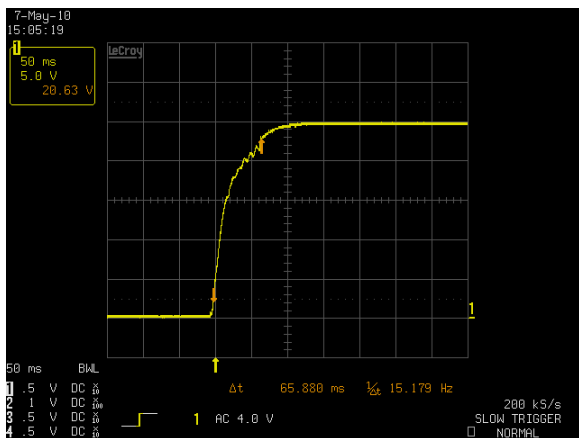

Figure 25: ADN20-24-1PM-C Output Voltage Startup Characteristic
Vin = 90Vac Load: Io = 20.0A, Output Capacitance = 330uF/A
Ch 1: Vo

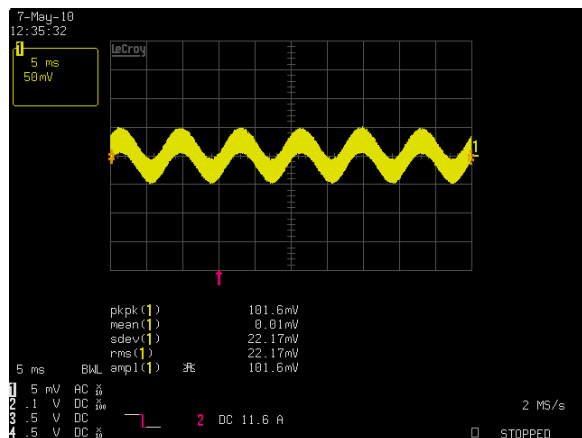

Figure 26: ADN20-24-1PM-C Ripple and Noise Measurement
Vin = 115Vac Load: Io = 20.0A
Ch 1: Vo

ADN20-24-1PM-C Performance Curves

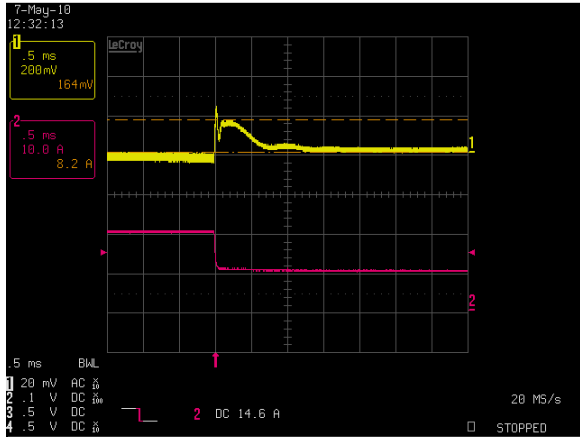

Figure 27: ADN20-24-1PM-C Transient Response – High to Low
Vin = 115Vac Load: Io = 100% to 50% load change, 1A/us slew rate
Ch 1: Vo Ch 2: Io

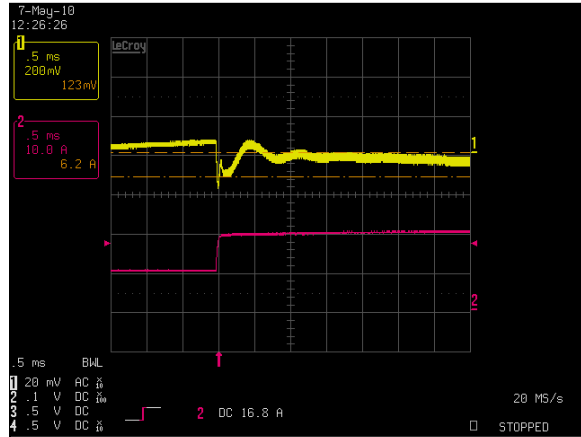

Figure 28: ADN20-24-1PM-C Transient Response – Low to High
Vin = 115Vac Load: Io = 50% to 100% load change, 1A/us slew rate
Ch 1: Vo Ch 2: Io

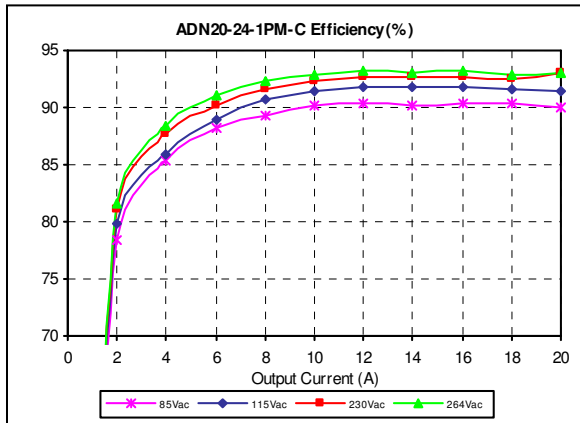

Figure 29: ADN20-24-1PM-C Efficiency Curves @ 25 °C, Convection Cool
Vin = 85 to 264Vac Load: Io = 0 to 20.0A

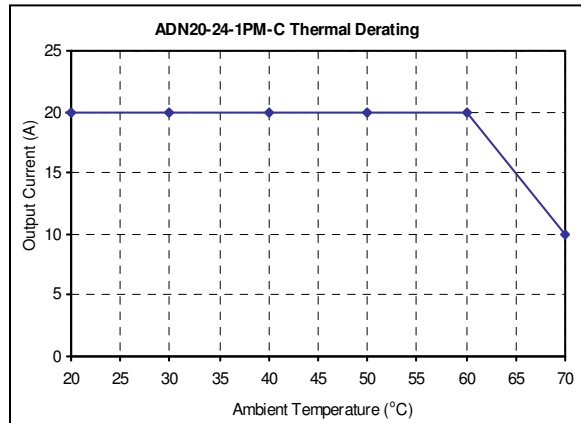

Figure 30: ADN20-24-1PM-C Derating Curve
Vin = 115Vac Load: Io = 0 to 20.0A

Protection Function Specifications

Rev.10.07.06_#2.0
ADN-C Series
Page 12

Over Voltage Protection (OVP)

The power supply main Vo output will latch off during output overvoltage condition with the AC line recycled to reset the latch.

Over Current Protection and PowerBoost™

With PowerBoost™, the ADN-C power supplies can supply a higher output current for a short period of time without the output voltage breaking down. When an overload occurs, the output current can increase up to 1.5 times its nominal rating for four seconds. If the overload lasting for longer than 4 seconds, the power supply will go into hiccup mode for protection. Refer to PowerBoost™ diagram below for details.

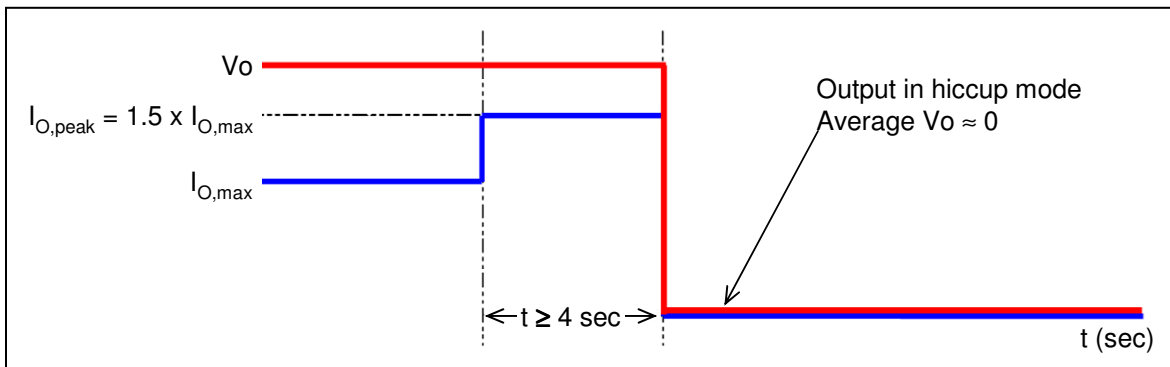

Short Circuit Protection (SCP)

The ADN-C series power supply is protected against short circuit to its output. A short circuit is defined as 0.03-ohm resistance or less between the output terminals. When a short circuit condition occurs, the output current can reach 160% of the rated current or higher, the output will shut off immediately and goes into hiccup mode.

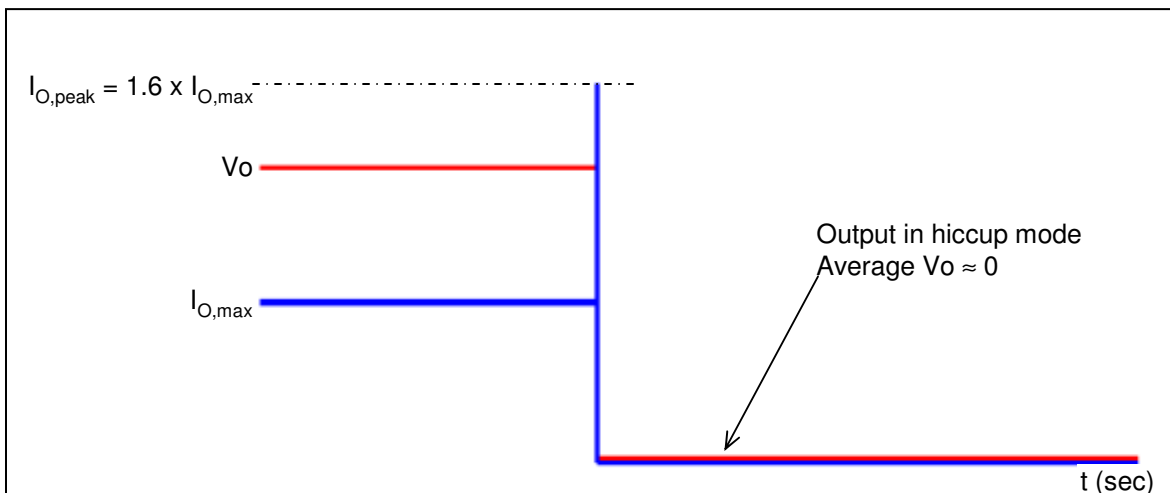

Mechanical Specifications

Mechanical Outlines

ADN5-24-1PM-C

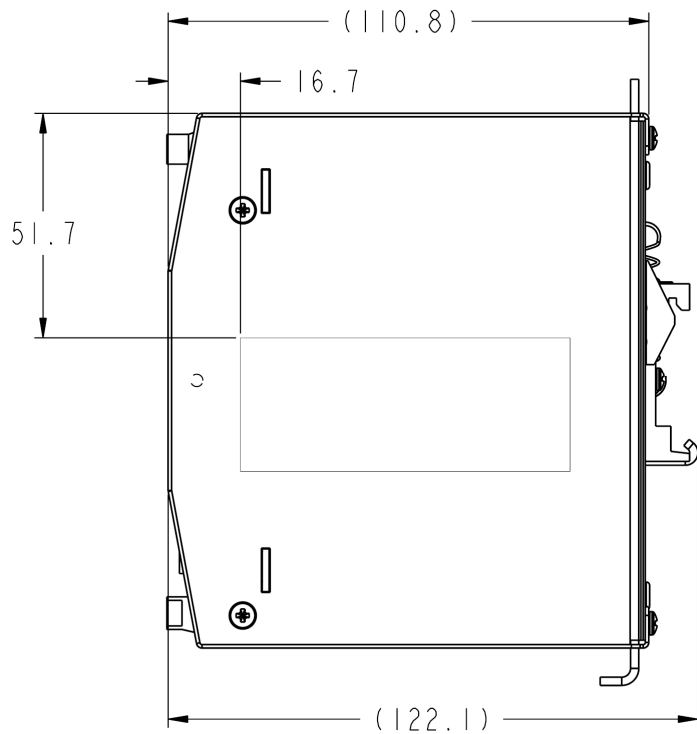
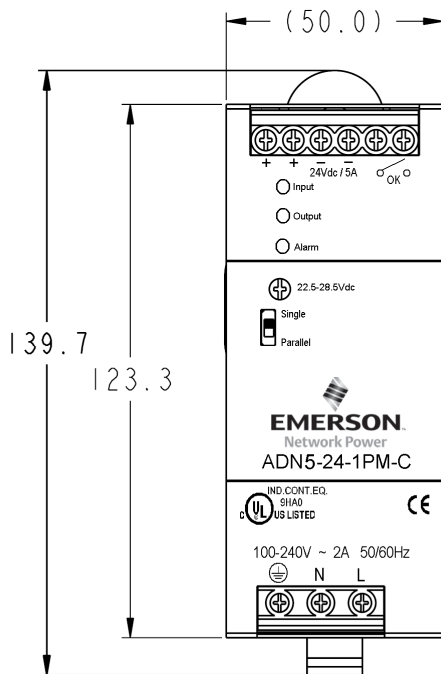
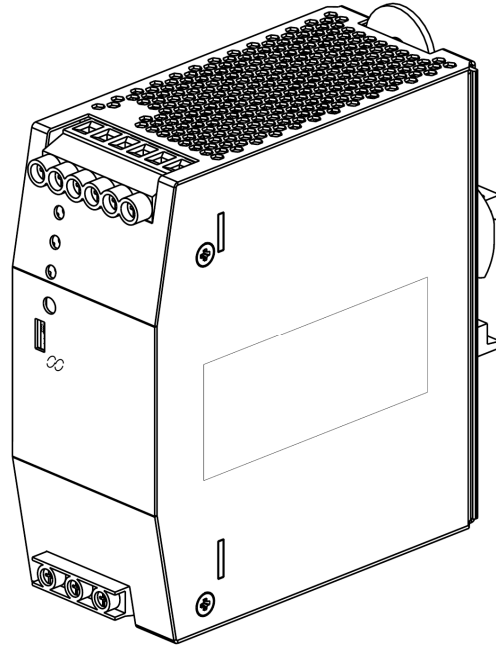
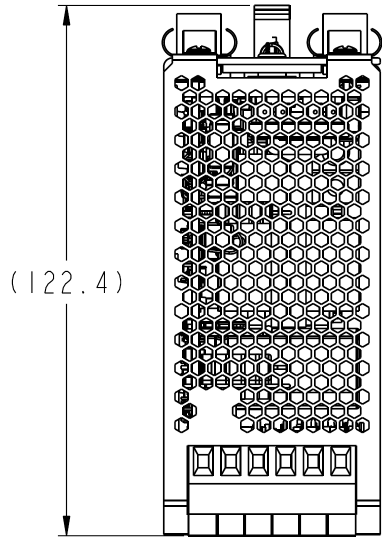

Mechanical Outlines

ADN10-24-1PM-C

Rev.10.07.06 #2.0
ADN-C Series
Page 14

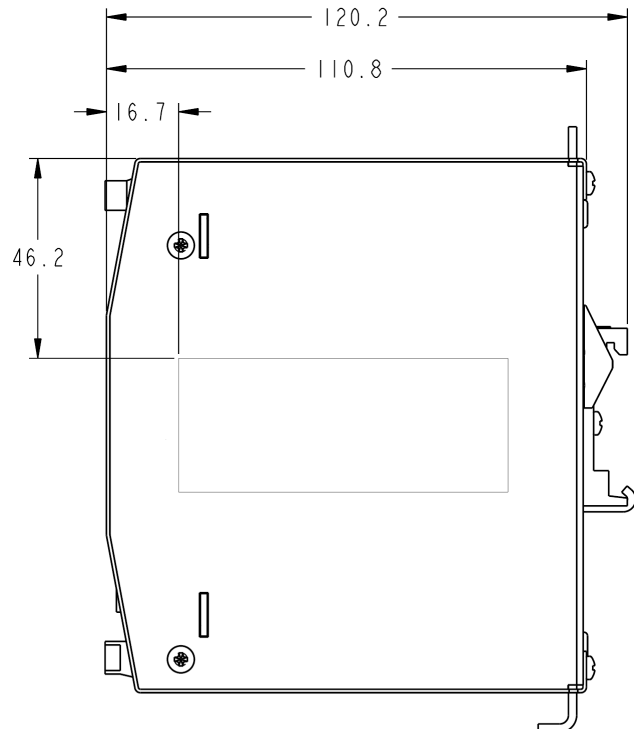
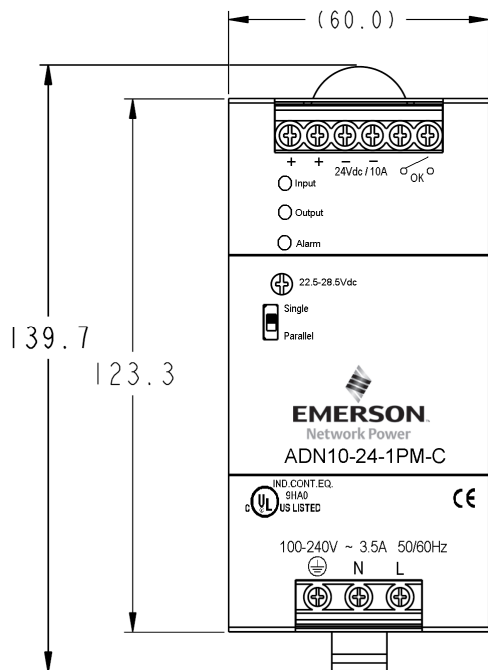
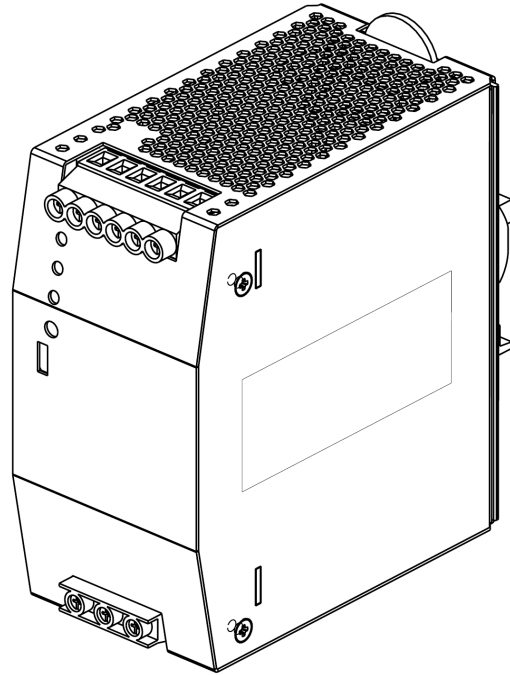
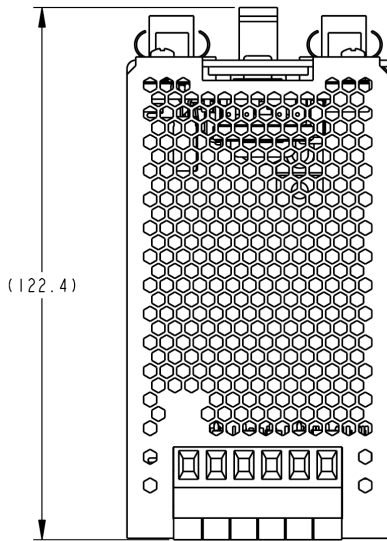

Mechanical Outlines

ADN20-24-1PM-C

Rev.10.07.06 #2.0
ADN-C Series
Page 15

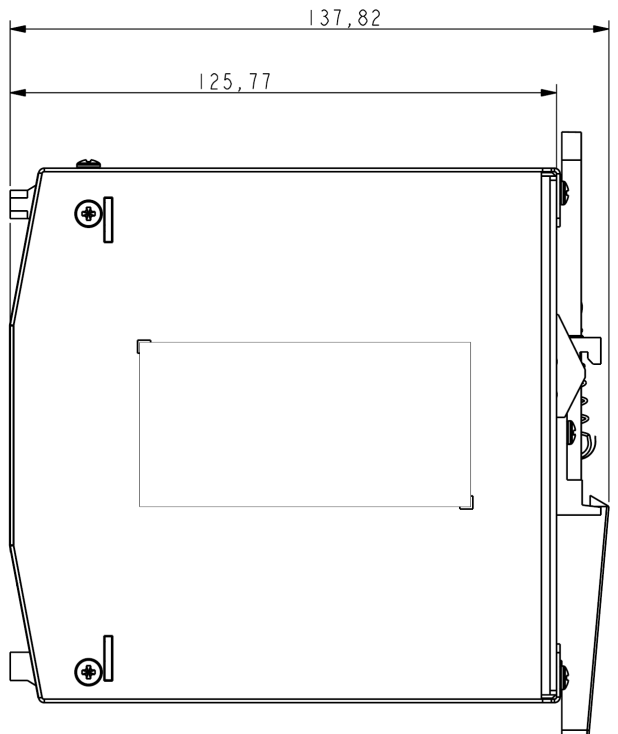
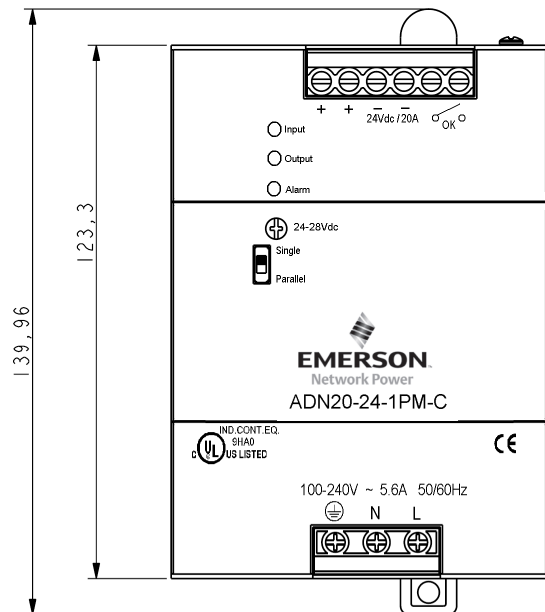
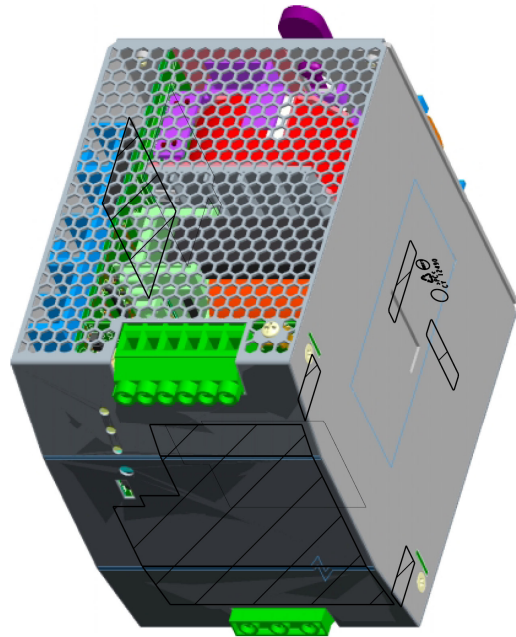
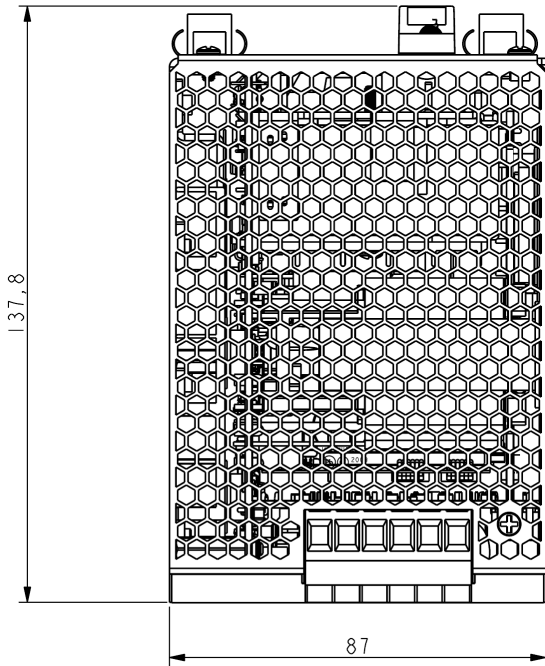

Mounting

DIN rail mounting

(DIN TS35/7.5 or TS35/15 rail system)

1. Tilt unit slightly backwards
2. Put it onto the DIN Rail
3. Push downwards until stopped
4. Push at the lower front edge to lock
5. Shake the unit slightly to ensure that the retainer has locked

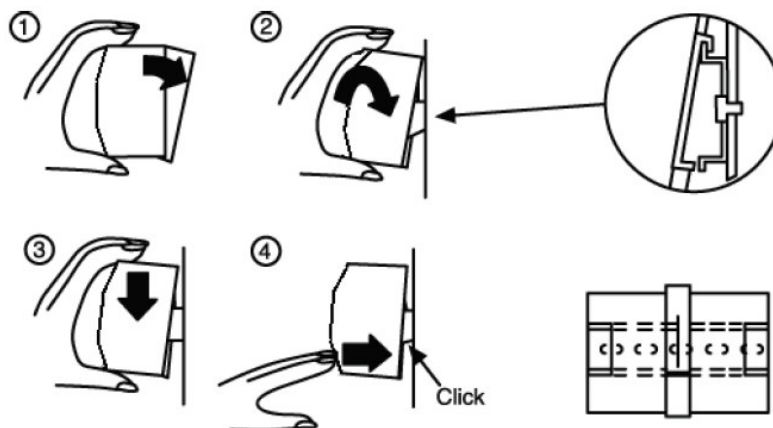

Alternative Panel Mount: Using the optional accessory, the unit can be screw mounted to a panel.

Detachment from DIN rail:

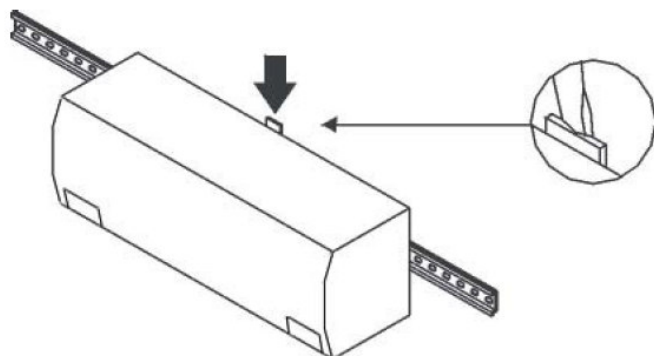

Chassis mounting

Instead of mounting on DIN rail, a ADN-C series power supply can also be attached to chassis by using two metal brackets, which replace the existing two aluminum profiles.

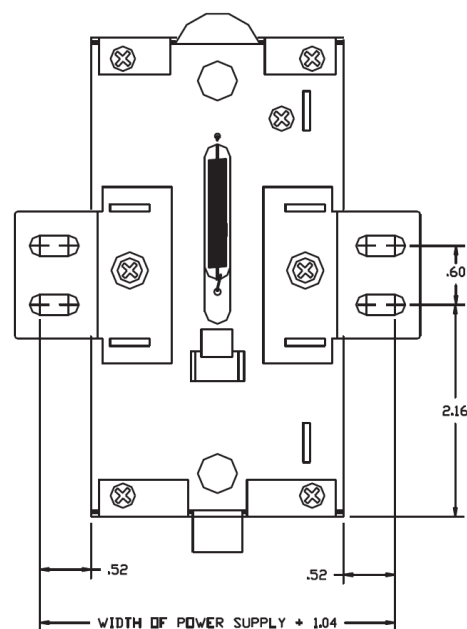
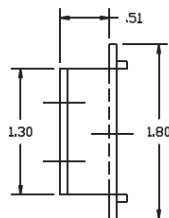
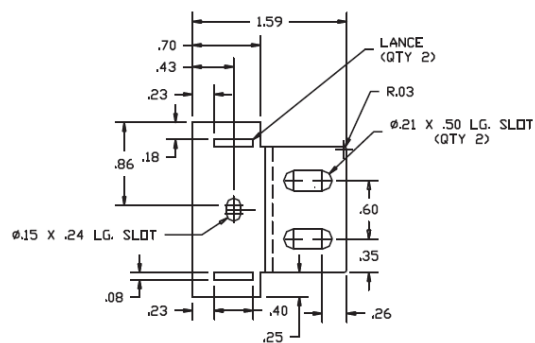

Mounting Orientations

Rev.10.07.06 #2.0
ADN-C Series
Page 17

Vertical (Standard)

- AC Input connector on TOP
- LED indicators face FRONT
- No derating require

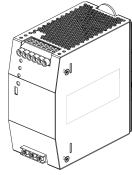

Horizontal (Sideways mount)

- AC Input and Output connectors on horizontal plane
- LED indicators face FRONT
- Maximum output = 50% rated output current



Top mount (Front side up)

- LED indicators face UP
- Maximum output = 50% rated output current

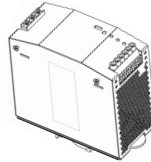

Mounting Space

Free space (minimum)

- ADN5-24-1PM-C / ADN10-24-1PM-C - 15mm in front, 25mm above and below, 10mm left and right
ADN20-24-1PM-C - 15mm in front, 40mm above and below, 10mm left and right

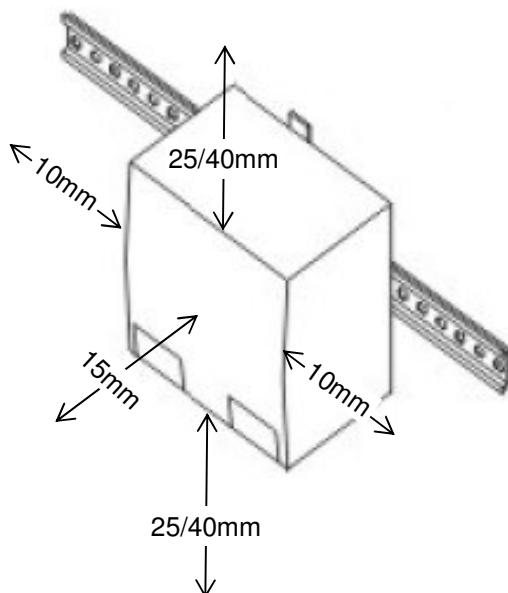

Connector Definitions

Rev.10.07.06 #2.0
ADN-C Series
Page 18

AC Input Connector

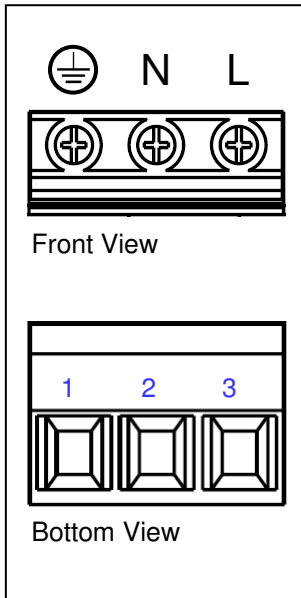

Output Connector

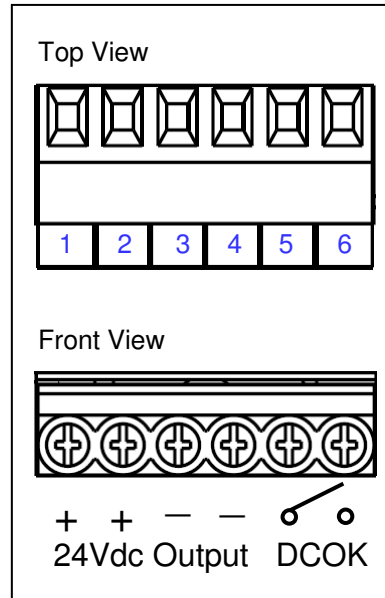

Connector Type and Wire Sizes

Table 7. Connector type on ADN-C series

Reference	Description	Wire Size
Input AC Connector	3-Pole, 9.52mm Pitch, Euro Type, Cage Clamp Terminal Block	10 to 16 AWG (1.5 to 6 mm ²) solid wire
Output Connector	6-Pole, 6.35mm Pitch, Euro Type, Cage Clamp Terminal Block	10 to 16 AWG (1.5 to 6 mm ²) solid wire

AC Input Connector

These terminals supply the AC Mains to the ADN-C series power supply.

- Pin 1 - Earth Ground (Safety Ground)
- Pin 2 - Neutral
- Pin 3 - Line

Output Connector

Rev.10.07.06 #2.0
ADN-C Series
Page 19

These terminals provide the main output for the ADN-C power supply and the DCOK contact output.

Pin 1 & 2 - (+) 24V Output (Vo)

Pin 3 & 4 - (-) 24V Output (Vo Return)

Pin 5 & 6 - DCOK

The Vo and the Vo Return terminals are the positive and negative rails, respectively of the main output of the ADN-C series power supply. The Main Output is electrically isolated from the Earth Ground and can be operated as a positive or negative output.

DCOK – (Pin 5 and Pin 6)

DCOK is a dry relay contact output capable of switching up to a maximum of 0.2A / 50Vdc

Relay contact **close** – DC OK – Output 24V available

Relay contact **open** – DC Fail – Output 24V failed

Switches and Potentiometer Definitions

Rev.10.07.06 #2.0
ADN-C Series
Page 20

Vo adjustment - The output of the ADN-C series power supply can be adjusted from its nominal output voltage via the front trim pot screw. Clockwise rotation will increase the output voltage while counterclockwise rotation will decrease the output voltage.

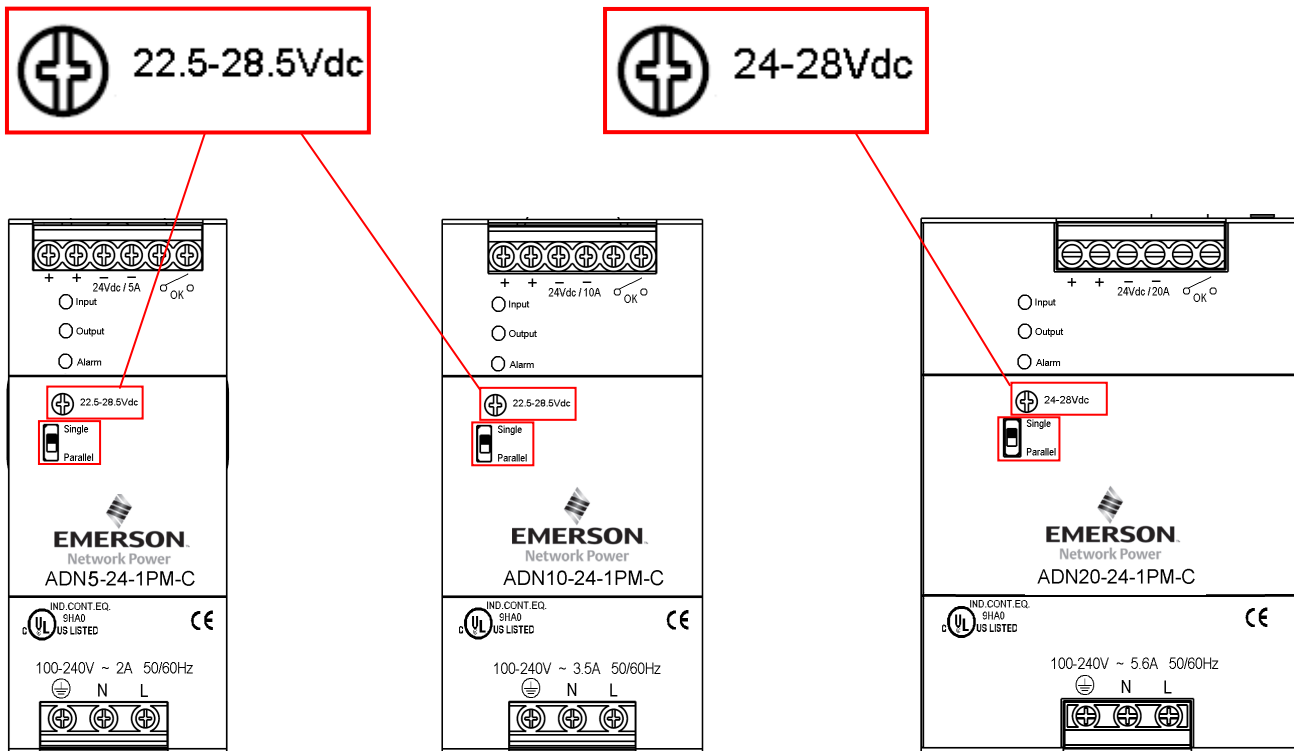

Single / Parallel switch - The outputs of two or more of ADN-C series power supplies can be connected in parallel to increase the total current capability. When operate the ADN-C power supplies in parallel, the Single / Parallel switch on each of the ADN-C power supply should be placed in the parallel position. Units will not be damaged by parallel operation (regardless of switch position setting)

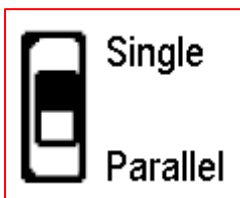

LED Indicator Definitions

Rev.10.07.06 #2.0
ADN-C Series
Page 21

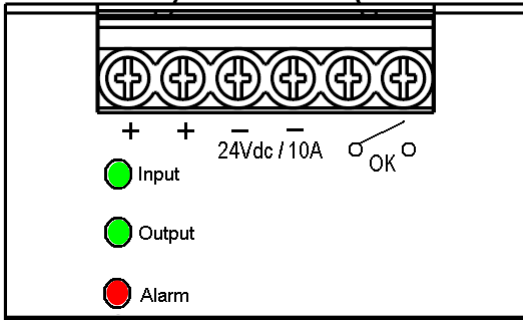

Three user-friendly LEDs for status and diagnostics
Shows status of input power, output power and alarm condition
Valuable troubleshooting aid to reduce system downtime

LED Diagnostics								
LED	OK	Loss of AC	Low AC	No DC	High Load	Overload	Hot	Too Hot
Input	Green	---	Amber	Green	Green	Green	Green	Green
Output	Green	---	Green	---	Amber	Amber	Green	---
Alarm	---	---	---	Red	Amber	Red	Amber	Amber

Weight

ADN5-24-1PM-C	- 1.65 lb (0.75kg)
ADN10-24-1PM-C	- 1.98 lb (0.90kg)
ADN20-24-1PM-C	- 2.60 lb (1.20kg)

EMC Immunity

The ADN-C Series power supply is designed to meet the following EMC immunity specifications

Table 5. Environmental Specifications:

Document	Description
EMC Emission:	
EN55011, Class B	Limits and methods of measurement of radio disturbance characteristics of industrial, scientific and medical (ISM) radiofrequency equipment
EN55022, Radiated and Conducted including Annex A	Information technology equipment. Radio disturbance characteristics. Limits and methods of measurement
EN61000-3-2	EMC limits for harmonic current emissions for equipment with input current up to and including 16A per phase
EN61000-6-3: 2001	EMC Emission standard for residential, commercial and light industrial environments
EMC Immunity:	
EN61000-6-1: 2001	Immunity Standard for Residential, Commercial and Light-Industrial Environments
EN61000-6-2: 2001	Immunity Standard for Industrial Environments
EN61000-4-2 Level 4	ESD, Electrostatic Discharge
EN61000-4-3 Level 3	Radiated, radio-frequency, electromagnetic field immunity test
EN61000-4-4 Level 4 input EN61000-4-4 Level 3 output	Electrical Fast Transient/Burst Immunity Test
EN61000-4-5 Isolation Class 4	Surge immunity test
EN61000-4-6 Level 3	Immunity to conducted disturbances, induced by radio-frequency fields
EN61000-4-11	EMC standard is applicable to power supplies whose input current (I_{IN}) is below 16A
IEC 61000-4-34	Voltage dip immunity standard
SEMI F47 Sag Immunity	
General Protection Safety:	
IEC536	Protection Class 1
IEC60529	IP20
IEC60950-1	SELV

Safety Certifications

Rev.10.07.06 #2.0
ADN-C Series
Page 24

The ADN-C series is suitable for use in Class I, Division 2, Groups A, B, C, and D hazardous locations or non-hazardous locations only.

The ADN-C series has been designed in accordance with following safety standards. Appropriate safety certificates and approvals are available to download from our website www.powerconversion.com.

Table 6. Safety Certifications for ADN-C series power supply

Document	Description
UL508 Listed, cULus	Standard for Industrial Control Equipment
UL60950-1, cRUus	Safety of information Technology Equipment
IEC/EN60950-1	Safety of information Technology Equipment
ATEX Certification	Class 1, Division 2 hazardous location, Groups A, B, C, D w/ T3A temp class up to 40°C Ambient
CB Certificate and Report	(All CENELEC Countries)
CE Mark	LVD (73/23 & 2004/108/EC) EMC (89/336 & 93/68/EEC)

Operating and Non-Operating Conditions

The ADN-C Series power supply is designed to meet all of its specifications during any combination of operating ambient conditions and after exposure to any combination of non-operating ambient conditions specified in this section.

Table 4. Maximum Ambient Conditions:

Parameter	Model	Symbol	Min	Typ	Max	Unit
Ambient Operating Temperature	ADN5 ADN10 ADN20	T_A	-10 -10 -25	- - -	+70 ¹ +70 ¹ +70 ¹	°C
Storage Temperature	All	T_{STG}	-25	-	+85	°C
Shock			Accordance to IEC 68-2-27			
Operating	ADN5 ADN10 ADN20		3g peak, 11 milliseconds half-sine pulse 15g peak, 11 milliseconds per IEC 60068-2-6 3g peak, 11 milliseconds half-sine pulse			
Vibration			Accordance to Vibration (Sinusoidal) per IEC 68-2-6			
Operating	All		0.15 gravity (g) peak, 5–500 Hz (swept sine); 5–500 Hz (random); vertical axis only			
MTBF	Convection	40 °C	ADN5 ADN10 ADN20	>550,000hrs >550,000hrs >450,000hrs		

Note 1 - Derate each output at 5% per degree C from 60°C to 70°C

Output Ripple and Noise Measurement

The setup outlined in the diagram below has been used for output voltage ripple and noise measurements on the ADN Series. When measuring output ripple and noise, The scope is connected to the circuit via an RGU58-50Ω cable. One side is BNC and the other is soldered to the PCB. Shield is grounded. Oscilloscope should be set to 50Ω input with 20 MHz bandwidth for this measurement.

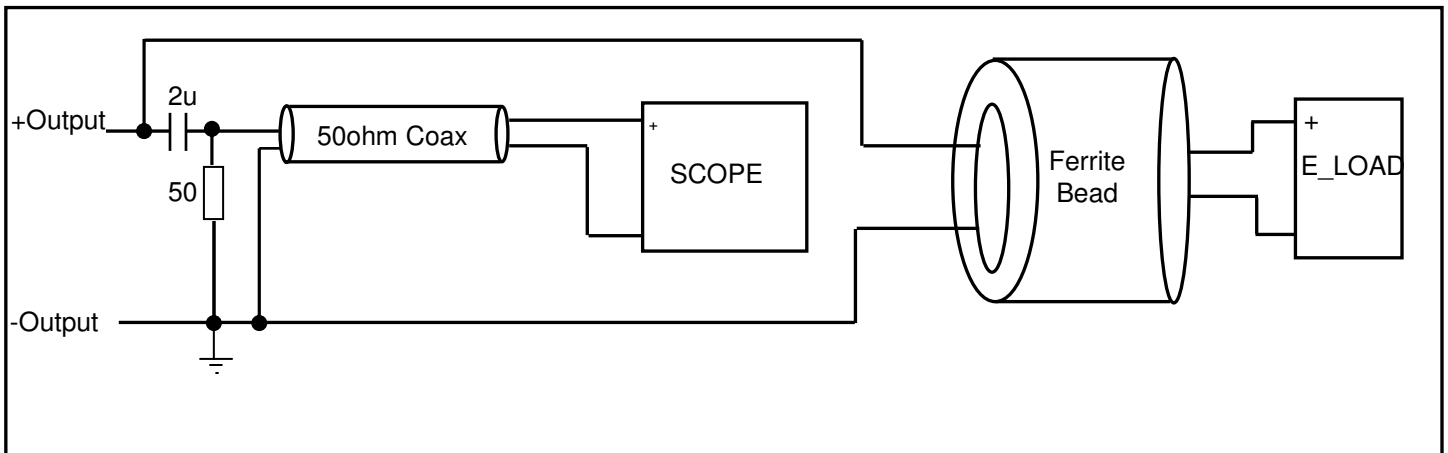

Common-Mode Noise

The setup outlined in the diagram below has been used for output voltage common-mode noise measurements on the ADN Series. The measurements are made individually (+) to GND or (-) to GND. The scope is connected to the circuit via an RGU58-50Ω cable. One side is BNC and the other is soldered to the PCB. Shield is grounded. Oscilloscope should be set to 50Ω input with 20 MHz bandwidth for this measurement.

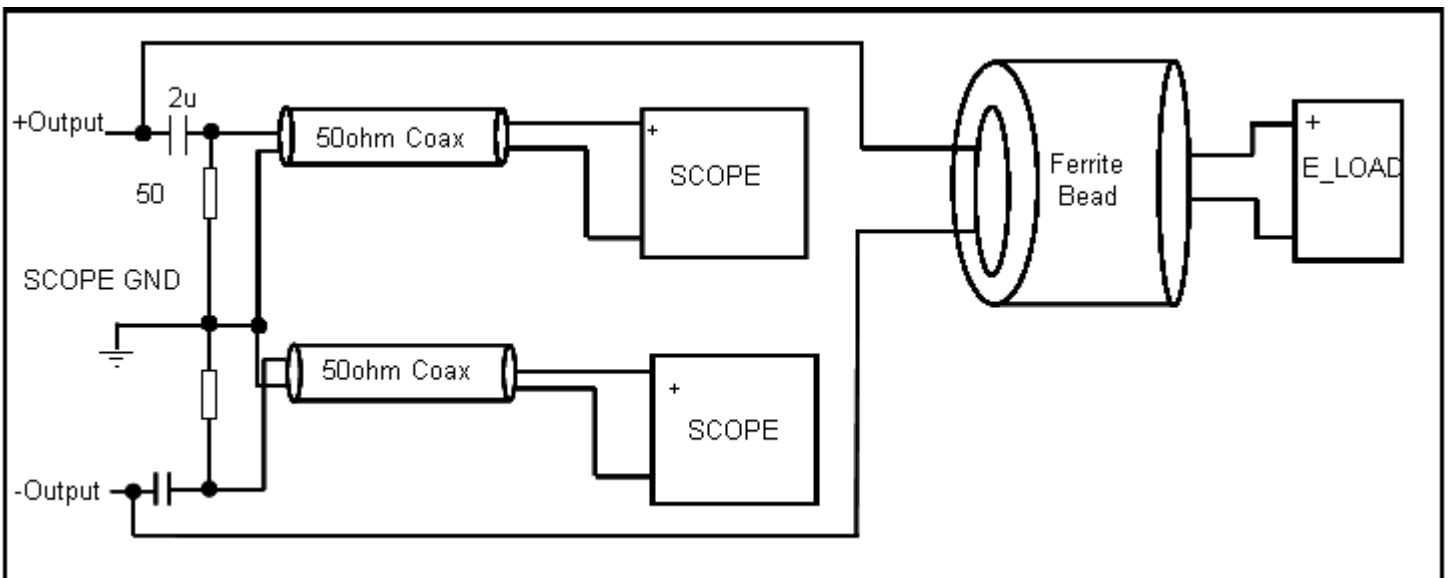

Americas

5810 Van Allen Way
Carlsbad, CA 92008
USA
Telephone: +1 (760) 930 4600
Facsimile: +1 (760) 930 0698

Europe (UK)

Waterfront Business Park
Merry Hill, Dudley
West Midlands, DY5 1LX
United Kingdom
Telephone: +44 (0) 1384 842 211
Facsimile: +44 (0) 1384 843 355

Asia (HK)

14/F, Lu Plaza
2 Wing Yip Street
Kwun Tong, Kowloon
Hong Kong
Telephone: +852 2176 3333
Facsimile: +852 2176 3888

For global contact, visit:

www.powerconversion.com

techsupport.embeddedpower@emerson.com

While every precaution has been taken to ensure accuracy and completeness in this literature, Emerson Network Power assumes no responsibility, and disclaims all liability for damages resulting from use of this information or for any errors or omissions.

Emerson Network Power.

The global leader in enabling business-critical continuity.

- AC Power
- Connectivity
- DC Power
- Embedded Computing
- **Embedded Power**
- Monitoring
- Outside Plant
- Power Switching & Controls
- Precision Cooling
- Racks & Integrated Cabinets
- Services
- Surge Protection

EmersonNetworkPower.Com

Emerson Network Power and the Emerson Network Power logo are trademarks and service marks of Emerson Electric Co.
©2008 Emerson Electric Co.