

APC18T12 Series: 12Vin / 18A Non-Isolated Point-of-Load

The APC18 DC-DC Power Module is a high efficiency non-isolated buck converter designed for use in a wide variety of applications. Packaged in an industry standard recognized SMT footprint: 1.3" x 0.53", it works from a wide input voltage range of 10V to 14V and offers a wide adjustable output range of 0.75V to 5.5V through external resistor programming.



Special Features

- Industry Standard SMT Footprint
- High Efficiency up to 95% at 5V output
- Adjustable output through external resistor programming
- Low output ripple and noise
- Input UVLO
- Fixed Switching Frequency
- Positive Enable
- Remote Sense pin

Environmental Specifications

- -40°C to 85°C Operating Temperature
- -40°C to 125°C Storage Temperature
- MTBF > 1 million hours

Electrical Parameters

Input

Input Range	10-14VDC
Input Surge	15V / 100ms

Control

Enable	TTL compatible
(Positive or Negative Logic Enable Options)	

Output

Load Current	Up to 18A max (Po £ 75W)
Line/Load Regulation	< 1% V _O
Ripple and Noise	50mV _{P-P} Typ
Output Voltage	
Adjust Range	0.75 – 5.5V _O
Transient Response	250mV Typ deviation
	50% step
	100ms settling time (Typ)
Remote Sense	+10%V _O
Over Current	120% max
Protection	
Over Voltage	130% max
Protection	
Over Temperature	110 °C
Protection	

Safety

UL + cUL 60950, Recognized
EN60950 through TUV-PS



Technical Reference Notes APC18T12 Series



Electrical Specifications

ABSOLUTE MAXIMUM RATINGS

Stresses in excess of the absolute maximum ratings can cause permanent damage to the converter. Functional operation of the device is converter is not implied at these or any other conditions in excess of those given in the operational section of the specs. Exposure to absolute maximum ratings for extended period can adversely affect device reliability.

Parameter	Device	Symbol	Min	Typ	Max	Unit
Input Voltage Continuous Transient (100ms)	All	V_{IN} $V_{IN,trans}$	- -	- -	14 15	Vdc
Isolation Voltage Input to Output	All		NA	-	-	
Operating Temperature	All	T_a	-40	-	85	°C
Storage Temperature	All	T_{STG}	-40	-	125	°C
Operating Humidity	All	-	10	-	85	%
Max Voltage at Enable Pin	All		-	-	15	Vdc
Max Output Power			-	-	80	W

INPUT SPECIFICATION

Parameter	Device	Symbol	Min	Typ	Max	Unit
Operating Input Voltage Range	All	V_{IN}	10.0	12.0	14.0	Vdc
Input Under-Voltage Lock-out T_ON Threshold T_OFF Threshold	All		9.0 8.0	- -	10.8 9.9	Vdc
Input Current ¹ ($V_{IN} = V_{IN,Min}$; $I_O = I_{O,Max}$)	All	I_{IN-MAX}	-	-	9.5	A
Max P_{diss} @ $I_O = 0A$ ($V_{IN} = V_{IN,Nom}$)	5.50V _O 0.75V _O		- -	- -	2 0.5	W
Input Ripple Current ² 5Hz to 20MHz	All	I_{II}	-	300		mAp-p



Technical Reference Notes APC18T12 Series



Electrical Specifications (continued)

OUTPUT SPECIFICATIONS

Parameter	Device	Symbol	Min	Typ	Max	Unit
Output Voltage Set point $V_{IN} = V_{IN, MIN}$ to $V_{IN, MAX}$; $I_O = I_{O, MAX}$		$V_{O, SET}$	0.735	0.75	0.765	Vdc
Output Regulation Line: $V_{IN} = V_{IN, min}$ to $V_{IN, max}$ Load: $I_O = I_{O, min}$ to $I_{O, max}$ Temp: $T_A = -40^\circ\text{C}$ to $+85^\circ\text{C}$	All	-	-	-	0.5	% % mV %
Ripple and Noise ⁴ Peak-to-Peak: (5Hz to 20MHz)	All	-	-	50	75	mVp-p
Output Current ⁵	All	I_O	0	-	18	A
External Load Capacitance Cap ESR = 1 mO Cap ESR = 10 mO	All				1000 5000	μF μF
Output Current-limit Inception ⁶	All	I_O		150%		
Over Temperature Range ⁶ (AVG. PCB TEMP, measured at R11 location)	All		95	-	120	$^\circ\text{C}$
Efficiency $V_{IN} = V_{IN, NOM}$ $I_O = I_{O, MAX}$; $T_A = 25^\circ\text{C}$	0.75V	η	76.0	78.0	-	%
	1.20V	η	83.0	84.5	-	%
	1.50V	η	85.5	87.0	-	%
	1.80V	η	87.0	88.5	-	%
	2.50V	η	89.5	91.0	-	%
	3.30V	η	91.5	92.5	-	%
	5.00V	η	93.5	94.5	-	%
Output voltage rise time $V_{IN} = V_{IN, MIN}$ to $V_{IN, MAX}$	All	-	-	3	6	ms
Enable to Output Turn-ON Delay $V_{IN} = V_{IN, MIN}$ to $V_{IN, MAX}$ $I_O = I_{O, MIN}$ to $I_{O, MAX}$	All	-	-	-	8	ms
Switching Frequency	All	-	-	300		kHz
Output Turn-on Overshoot Output Turn-off undershoot (Passive Resistive Full Load)	All	-	-	-	5 -0.5	% V_O V
Output Enable ON/OFF Positive Enable* Enable Pin Voltage: Mod-ON Mod-OFF	All	- -	2.6 0	- -	15 0.8	V V



Technical Reference Notes APC18T12 Series



Electrical Specifications (continued)

OUTPUT SPECIFICATIONS

Parameter	Device	Symbol	Min	Typ	Max	Unit
Dynamic Response ⁸ (C _O = 10uF Tantalum + 1uF Ceramic) Load Change of 50% step anywhere between 10% to 100% of rated load	$\Delta I_O/\Delta t$	-	-	2.5	-	A/ μ s
Peak Deviation	All	-	-	250	300	mV
Settling Time to V _{O, Nom} <5%		-	-	100	150	μ s
Peak deviation						
Dynamic Response ⁸ (C _O = 150uF x2 Special Polymer Aluminum Capacitors) Load Change of 50% step anywhere between 10% to 100% of rated load	$\Delta I_O/\Delta t$			2.5		A/ μ s
Peak Deviation	All			150	200	mV
Settling Time to V _{O, Nom} <5%				150	200	μ s
Peak deviation						
Output Voltage Trim Range ⁹	All		0.75		5.50	V
Remote Sense ¹⁰	All			-	10%	V

- NOTE: 1. The converter is not internally fused. Recommended external fuse, Cooper Bussman 6125FA12A or equivalent
2. External input capacitance required. See Figure 1.
4. Refer to Appendix A3 for the output ripple and Noise Test Measurement Setup.
5. Output current limited by 80W/V_o. Output Power Derating applies at elevated temperature. See Appendix B for the Thermal Derating Curves.
6. OCP and OTP are in hiccup mode. The converter will auto restart without the need to recycle the input voltage or toggle the enable signal and once the fault is removed. V_o higher than 1.5V, true OCP exists. V_o less than 1.5V, OTP is used for OCP. Over current of not higher 150% for V_o less than 1.5V is recommended. Typical overload condition is 150% or 27A. The module with V_o < 1.5V may not be survival from over current exceeding 30A.
8. Load step response shall be measured at the load side of the output capacitors. See Appendix A4 for the output and input cap requirement.
9. See appropriate Trim Equation and configuration in Appendix A6.
10. The combination of remote sense and output trim adjust cannot exceed 5.5V.

Electrical Specifications *(continued)*

SAFETY AGENCY / MATERIAL RATING / ISOLATION

Parameter	Device	
Safety Approval	All	UL/cUL 60950, Flammability and Temperature Rise
Material Flammability Rating	All	UL94V-0
Input to Output Insulation Type	All	Non-Isolated

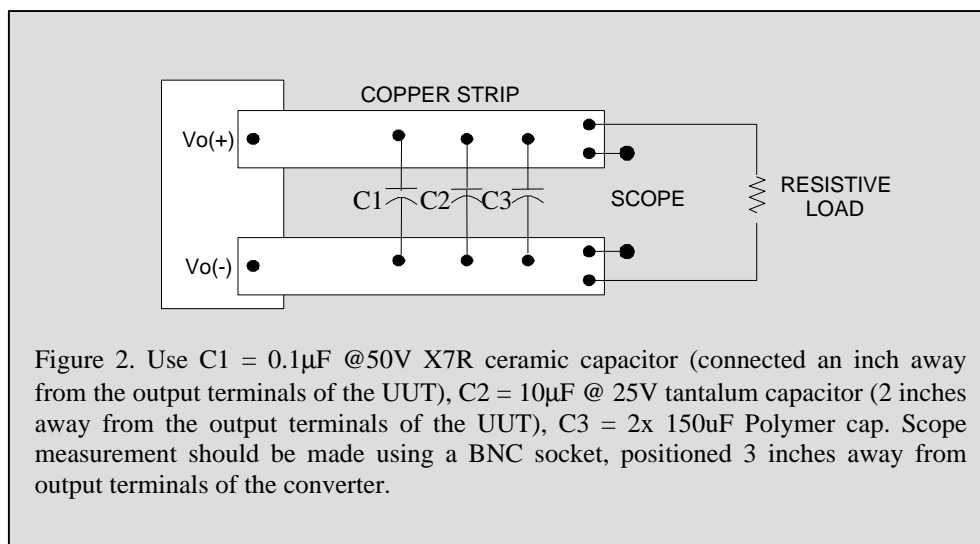
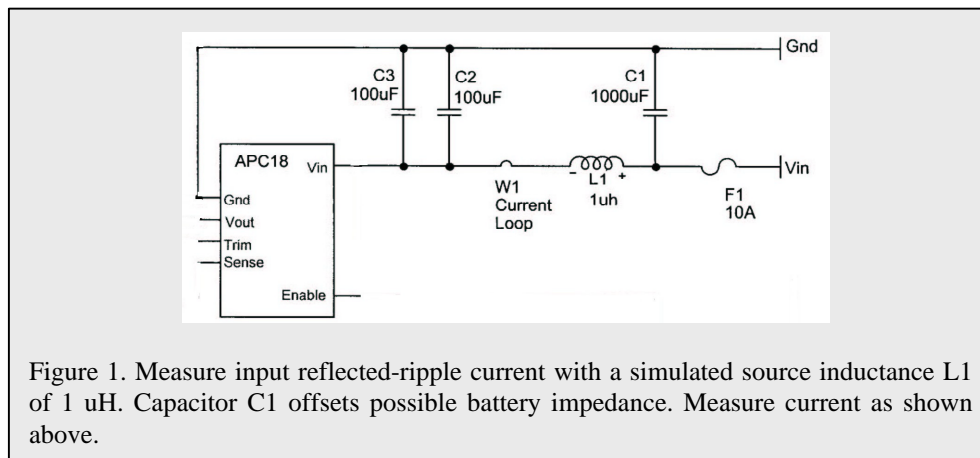

Typical Application Circuit

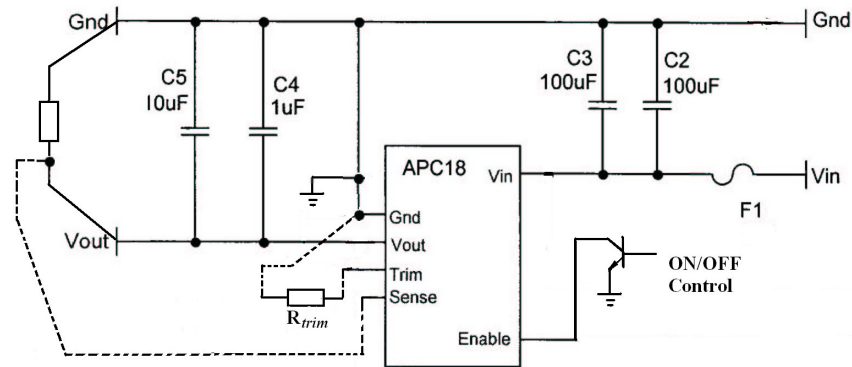

Figure 3. Typical Application Circuit

Enable Pin

The converter comes with an Enable pin primarily used to turn ON/OFF the converter. The converter is disabled (OFF) when the voltage across the Enable pin and ground is between 0V to 0.8V. The converter is Enabled (ON) when the voltage across the Enable pin and ground is between 2.6V to 15V (or the Enable Pin is left open).

Output Trim

Output voltage adjustment is accomplished by connecting an external resistor between the Trim Pin and Ground Pin terminals. Resistance and Output voltage relationship is established by Equation 1. If Trim pin is left open – default $V_o = 0.75V$

TRIM-UP EQUATION:

$$R_{trim} = \left(\frac{10500}{V_o - 0.75} - 1000 \right) \Omega \quad (1)$$

Where R_{trim} is the resistance value in ohms and V_o in Volts is the output voltage desired.

Table Rtrim values for different output voltage adjustment

V_o (V)	0.75	1.0	1.2	1.5	1.8	2.0	2.5	3.3	5.0
Rtrim (?) from Equation (1)	open	41.0K	22.3K	13.0K	9.00K	7.40K	5.00K	3.12K	1.47K
Rtrim (?) from E96	open	41.2K	22.1K	13.0K	9.09K	7.32K	4.99K	3.09K	1.47K

Performance Curves

Derating Curves

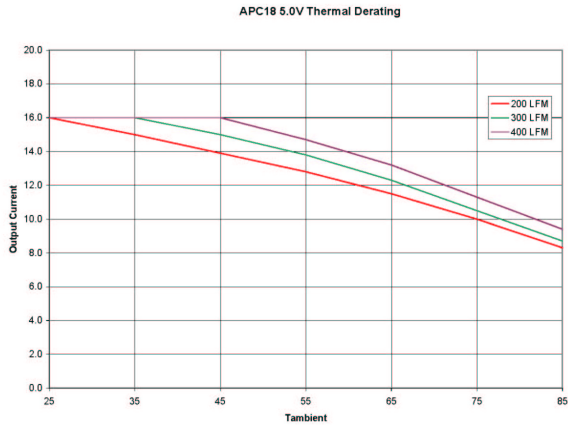

Figure 4. Output derating curve at $V_{IN} = 12V$, $V_O = 5V$.

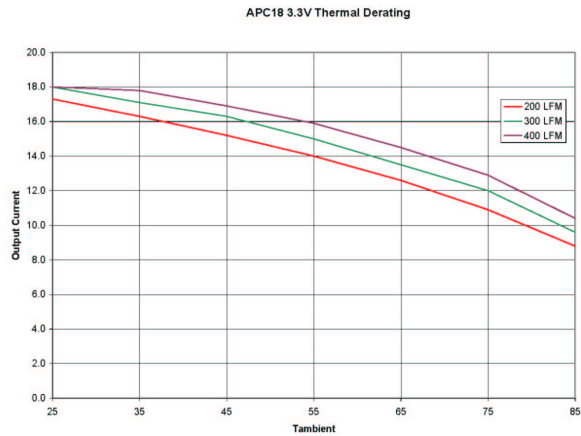

Figure 5. Output derating curve at $V_{IN} = 12V$, $V_O = 3.3V$.

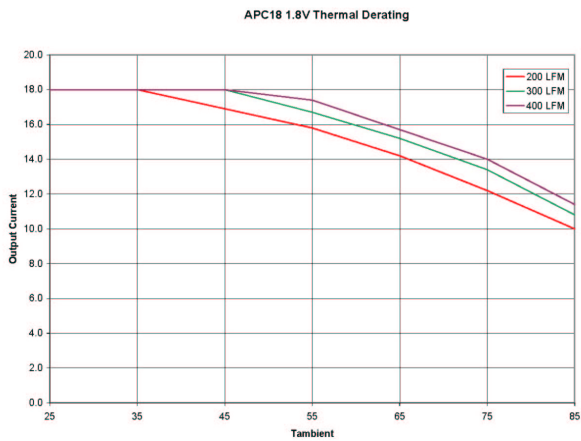

Figure 7. Output derating curve at $V_{IN} = 12V$, $V_O = 1.8V$.

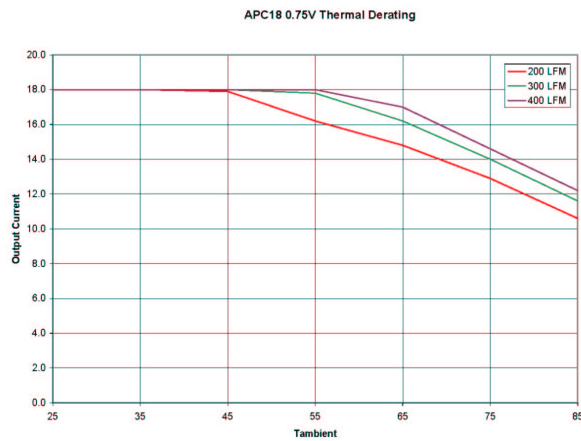

Figure 7. Output derating curve at $V_{IN} = 12V$, $V_O = 0.75V$.

Mechanical Specifications

Parameter	Device	Symbol	Min	Typ	Max	Unit
Dimension	All	L	-	-	1.30 [33.02]	in [mm]
		W	-	-	0.53 [13.46]	in [mm]
	AEO	H	-	-	0.35 [8.89]	in [mm]
Weight	AEO		-	5 [0.16]	10 [0.32]	g [oz]

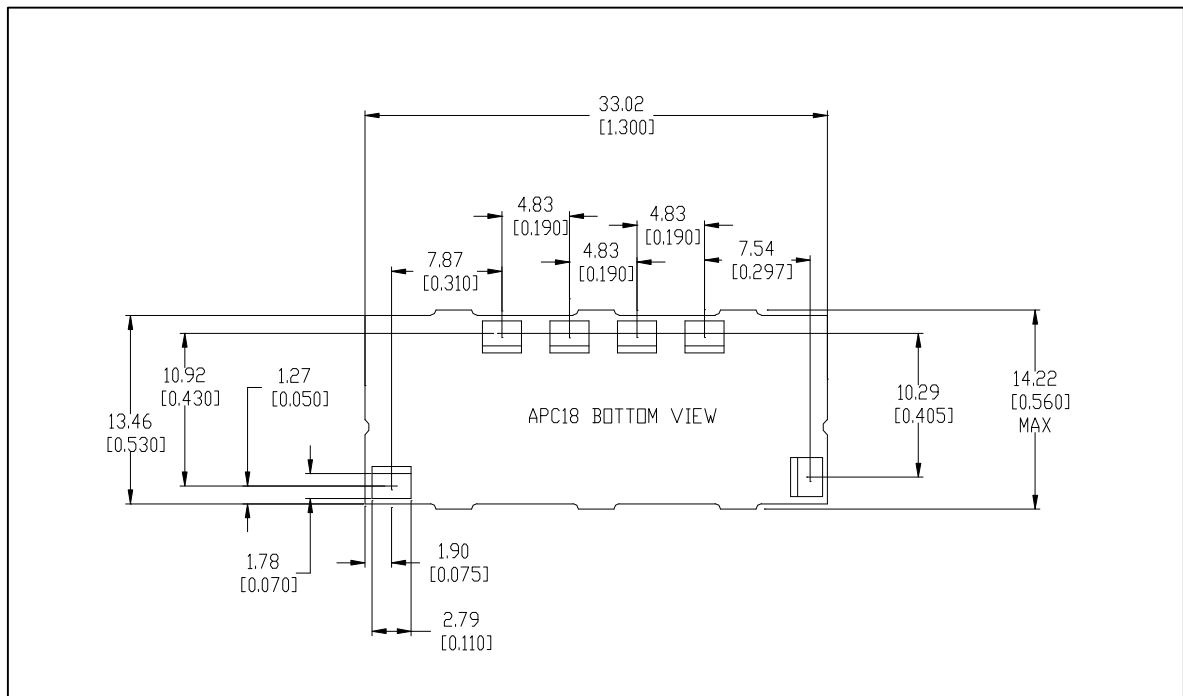

Figure 8. Mechanical Outline

PIN NAME	DESIGNATION
+V _{IN}	+ Input Voltage
Enable	ON/OFF
GND	Return for V _{IN} and V _O
Sense	+Output Sense pin
V _O	+Output
Trim	V _O Adjust



Figure 9. PIN designation.

RECOMMENDED LOCATION FOR PICK AND PLACE

The flat top surface of the large inductor (topside of the board) provides a versatile and convenient way of picking up the module (see Figure 10). A 6-7mm outside diameter nozzle from a conventional SMD machine is recommended to attain maximum vacuum pick-up. Nozzle travel and rotation speed should be controlled to prevent this off-centered picked-up module from falling off the nozzle. The use of vision recognition systems for placement accuracy will be very helpful.

REFLOW NOTES / RECOMMENDATIONS

1. Refer to the recommended Reflow Profile per Figure 11. Profile parameters exceeding the recommended maximums may result to permanent damage to the module.
2. The module is recommended for topside reflow process to the host card. For other orientations, contact factory.
3. In the event that the module needs to be desoldered from the host card, some pins may be detached from the module.

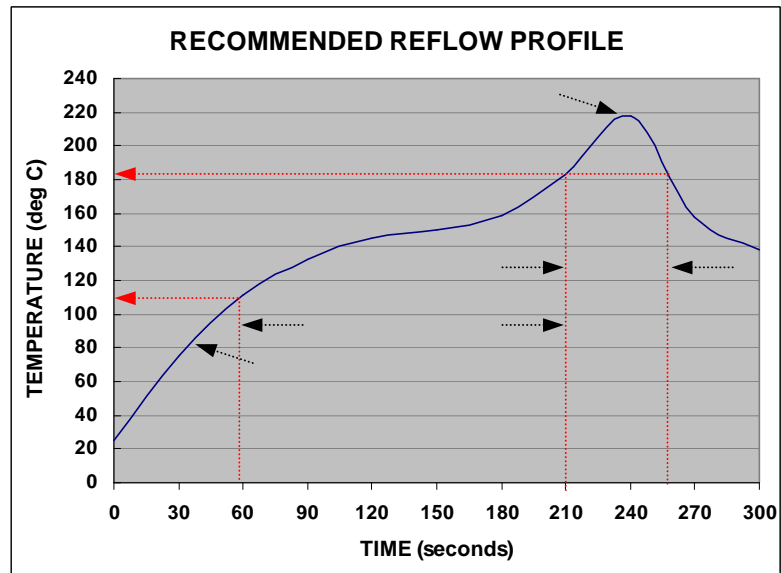

Figure 10. Recommended Reflow profile.

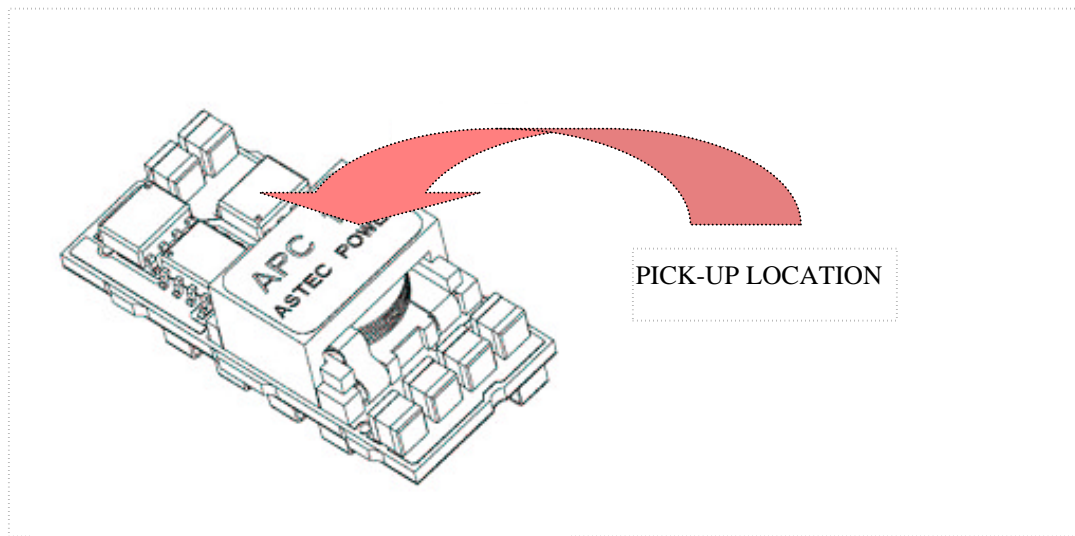

Figure 11. Recommended Pick-up location.



Technical Reference Notes
APC18T12 Series



TABLE 2: PART NUMBERING SCHEME

APC	O/P CURRENT	O/P VOLTAGE	I/P Voltage	-	9	OPTIONS
	xx 18 = 18A	y T = 0.75V	12 12 = 10V – 14V			z J = Tray packaging Non “J” = T&R packaging