

Limitless™ Wireless Solutions

Honeywell



**Imagine a world without wires.
What would you do with more freedom?**



It's time to retire the wire. To give your best ideas free rein. Honeywell's Limitless™ Series of wireless limit switches and receivers allows you to go farther, work smarter, and explore more possibilities than ever before.

Honeywell's Limitless™ series of switch solutions is leading the way. Honeywell Sensing and Control developed this technology to be a cutting-edge, cost-saving solution. That innovation starts whether you're retrofitting into an existing industrial or transportation application, or starting a new design. Now you have the freedom to push your designs and applications further and expand your vision.

For far too long, technology has been tied to the same old way of transmitting and connecting. But there's a price to pay for clinging to wired technology. There's an intangible cost in man-hours and missed production hours. And there are tangible costs — actual wear-and tear on equipment wiring and connections that can cause complete disruption of your operation.

Imagine how much could be saved once your best ideas were given free rein...

It's time to discover the possibilities.
Choose wireless Limitless™
switches to give your ideas free rein.

More distance - Limitless™ devices have up to a 305 m [1000 ft] line-of-sight range without using repeaters, depending on antenna type

More durability - Limitless™ Series offerings will include versions with an all-metal body and drive train, low-temperature capability, and/or enclosure with an anti-corrosion epoxy coating

More savings - Limitless™ switches can greatly reduce the costs of wiring, installation, and maintenance for all devices and equipment

More security - Limitless™ products conform to the international IEEE 802.15.4 standard and feature 16-bit address and 128-bit AES security keys

More flexibility - Since you're no longer tethered by wire, you can reconfigure and network multiple switches, easily allowing addition, subtraction, or relocation of Limitless™ switches

More diagnostics - Limitless™ user-friendly software provides information on battery health, and signal strength for each specific input

More standard options - Limitless™ products use a globally license-free, 802.15.4 RF radio and commercially available batteries for easy replacement anywhere in the world

Limitless™ Limit Switch Series

WGLA Global Limit Switches

WLS Heavy-Duty Limit Switches

Honeywell's Limitless™ product line combines the best of Honeywell's global limit switches with the latest commercial state-of-the-art wireless technology. Wireless-enabled limit switches can be used for position sensing and presence/absence detection for an endless number of applications.

The Limitless™ Series is especially beneficial for remote monitoring applications where wiring or wire maintenance is not physically possible or economically feasible. Combining this greater flexibility with proven harsh-duty packaging can result in increased efficiencies for machines, equipment, OEMs, and operators.

FEATURES

Wireless Design

- Radio (license-free and global*): WPAN 802.15.4, 2.4 GHz, point-to-point
- FCC 15, IC, ACMA, COFETEL, IDA, ETSI, WPC, SRRC, KCC, and ANATEL (see specific product series for applicable approvals)
- RoHS compliant
- EMI resistance protects against external interference
- In excess of 305 m [1000 ft] line-of-sight communication
- Reliable, flexible, and secure wireless transmission
- Standard replaceable battery with ultra-low power consumption
- Direct or remote mount antenna options

WGLA Series Features

- EN50041 metal enclosure
- IP67; NEMA 1,4,12,13
- Multiple operating heads and lever options
- Modular construction of components

WLS Series Features

- EN 50041 metal enclosure
- IP67/IP68; NEMA 1, 3, 4, 6, 6P, 12, 13
- Unique all-metal drive train
- Twin shaft seals (rotary)
- Zinc head and body are phosphate treated and epoxy finished making it less susceptible to effects from environmental exposure
- Full complement of operating heads and levers
- Chemical resistant fluorocarbon seals (optional)

BENEFITS

- Enables wireless presence/absence detection in applications/machinery where wiring is challenging or not feasible
- Integration of existing wireless technology with the superior reliability of Honeywell's MICRO SWITCH™ limit switch series
- Ability to reconfigure and network multiple switches, easily allowing addition, subtraction or relocation of Limitless™ switches in the application
- Reduces installation/maintenance costs with no wires, conduit, strain relief, clips, connectors, or connection boxes
- Output options
 - Panel-mount monitor: visual, audible (buzzer), one NPN output
 - DIN-mount receiver: visual, 14 NPN/PNP-type outputs
- Consumes ultra-low power to prolong battery life (replaceable)
- RF board operating in 2.4 GHz globally license-free frequency band; WPAN 802.15.4
- SIL reliability data available upon request

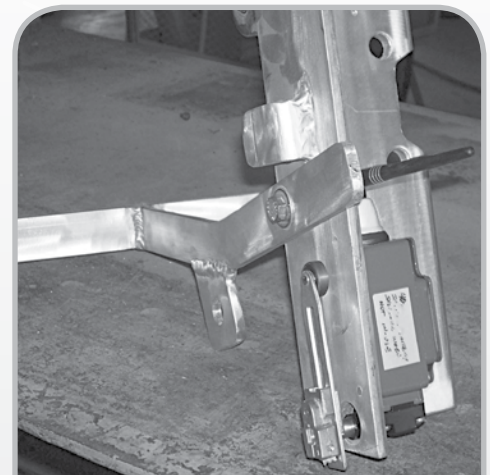

APPLICATIONS

- Construction/ag machines
- Conveyors
- Crane boom/jib/skew position
- Door position
- Grain diverters or flaps
- Hose attachment verification
- Lifts
- Material handling
- Movable machinery
- Presses
- Remote or temporary equipment
- Specialty machines
- Valve position

*Some countries require specific communication certifications. Contact Honeywell for existing certification information.



WGLA Series



WLS Series

Limitless™ global limit switches	Product type	Limitless™ heavy-duty limit switches
Global, license-free RF bands*	Availability	Global, license-free RF bands*
Reference WGLA installation drawing	Operating characteristics	Reference WLS installation drawing
Side rotary, top plunger, top roller, top roller lever	Actuator	Side rotary, top plunger, side plunger, top roller plunger, top adjustable plunger, wobble stick
Rotary lever included w/side rotary; other lever options available	Lever type	Many rotary lever options available
Zinc head and body are phosphate treated and epoxy finished	Housing material	Zinc head and body are phosphate treated and epoxy finished
EN 50041	Housing type	WLS (EN 50041)
WPAN 802.15.4; 2.4 GHz point-to-point; specific country communication agency approval required	Radio	WPAN 802.15.4; 2.4 GHz point-to-point; specific country communication agency approval required
Direct or remote-mount antenna options; omni-directional	Antenna type	Direct or remote-mount antenna options; omni-directional
In excess of 305 m [1000 ft] line-of-sight communication between Limitless™ switches and monitor/receiver when using 2.2dBi integral antenna	Signal range	In excess of 305 m [1000 ft] line-of-sight communication between Limitless™ switches and monitor/receiver when using 2.2dBi integral antenna
3.6 Vdc Lithium Thionyl Chloride; 2/3 AA size manufactured by Green Energy p/n ER14335M; Honeywell p/n WBT1	Battery	3.6 Vdc Lithium Thionyl Chloride; 2/3 AA size manufactured by Green Energy p/n ER14335M; Honeywell p/n WBT1
IP67; NEMA 1, 4, 12, 13	Sealing	IP67, IP68; NEMA 1, 3, 4, 6, 6P, 12, 13
Latest applicable standards: EN 300 328, V1.7.1; EN 61326-1 (2006); EN 301 489-1, V1.8.1; EN 301 489-17, V2.1.1	EMC	Latest applicable standards: EN 300 328, V1.7.1; EN 61326-1 (2006); EN 301 489-1, V1.8.1; EN 301 489-17, V2.1.1
IEC 60068-2-27; half sine, 10 g, 6 mS, 3 axis	Shock	IEC 60068-2-27; half sine, 50 g, 6 mS, 3 axis
IEC 60068-2-6; 10 Hz to 500 Hz w/ 0,35 mm peak-to-peak, 58 Hz to 500 Hz, 5 g	Vibration	IEC 60068-2-6; 10 Hz to 58 Hz w/ 0,35 mm peak-to-peak, 58 Hz to 500 Hz, 5 g
-40 °C to 85 °C [-40 °F to 185 °F] (side rotary and side plunger) -25 °C to 85 °C [-13 °F to 185 °F] (all other actuators)	Operating temperature	-40 °C to 85 °C [-40 °F to 185 °F] -30 °C to 85 °C [-22 °F to 185 °F](wobble sticks)
FCC 15.247 Industry Canada RSS 210 ETSI, CE mark ACMA, C-Tick mark COFETEL IDA; ANATEL; SRRC; KCC; WPC	Agency approvals and standards	FCC 15.247 Industry Canada RSS 210 ETSI, CE mark ACMA, C-Tick mark COFETEL IDA; ANATEL; SRRC; KCC; WPC

*Some countries require specific communication certifications.
Contact Honeywell for existing certification information.

Limitless™ Limit Switch Series

WGLA and WLS Series

Dimensions and Ordering Options

WGLA Series

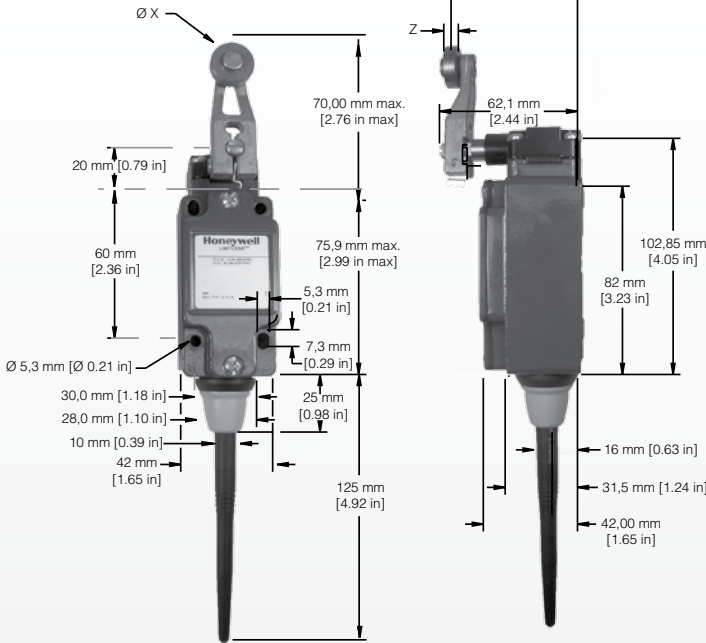

Lever	Roller Material	X Dim	Y Dim	Z Dim
GLZ51A	Nylon	19,1 mm [0.75 in]	55,9 mm [2.2 in]	6,4 mm [0.25 in]
GLZ51B	Steel	19,1 mm [0.75 in]	55,9 mm [2.2 in]	6,4 mm [0.25 in]
GLZ51T	Stainless Steel	19,1 mm [0.75 in]	56,8 mm [2.24 in]	8,8 mm [0.35 in]
GLZ51Y	Rubber	50,0 mm [1.97 in]	66,1 mm [2.60 in]	10,0 mm [0.39 in]

WLS Series

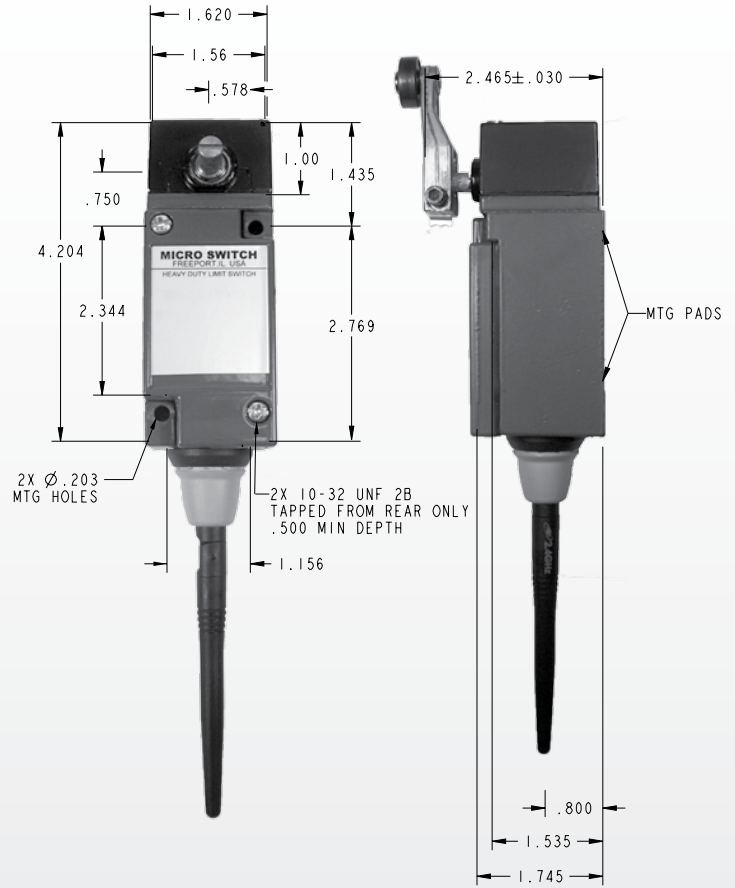

WGLA NOMENCLATURE

WGLA	1	A	00	A	A	1	A	3
Switch type	Gen Code	RF Code	Antenna type code	Country use code	Operating head code	Lever code ⁴	Roller code mm[in]	Modification code
WGLA Series Wireless	1 Version 1	A 2.4 GHz; IEEE 802.15.4	00 No antenna; RP-SMA connector jack	A US, Canada, Mexico	A Side rotary, momentary	Not applicable	Not applicable	Not applicable
			01 2.2 dBi omni w/switch mount; straight design	B All other approved countries ^{1, 2, 3}	B Top pin plunger	1 Standard fixed length	A 19 x 6.35 [0.75 x 0.25] nylon	3 Head assembled with actuator to right side
			02 2.2 dBi omni w/switch mount; tilt/swivel	*Use with antenna type codes 00-03, 05, 10, 11 only; usage also allowed in Country Code A. *Some countries require specific communication certifications. Contact Honeywell for existing certification information. *If Limitless devices are used on machinery that may shipped globally, use country code "B".	C Top roller plunger	2 Adjustable roller	B 19 x 6.35 [0.75 x 0.25] steel	4 Head assembled with actuator to left side
			03 3.0 dBi omni w/remote adhesive mount 9.8 ft cable		D Top roller lever	3 Yoke roller	D 38.1 x 6.35 [1.5 x 0.25] nylon	5 Head assembled with actuator to mounting surface
			04 5.5 dBi omni w/remote mag. mount, tilt/swivel, 5 ft cable		4 Adjustable rod	4 Adjustable rod	J 200 mm aluminum adjustable rod	6 Roller perpendicular to mounting surface
			05 5.5 dBi omni w/remote mag. mount, tilt/swivel, 10 ft cable		5 Offset	5 Offset	K 140 mm aluminum adjustable rod	
			06 9.0 dBi omni w/remote mag. mount, tilt/swivel 5 ft cable				N 318 mm stainless steel adjustable rod	
			07 9.0 dBi omni w/remote mag. mount, tilt/swivel 10ft cable				W 40.0 x 12.7 [1.5 x 0.5] rubber	
			08 8.0 dBi omni w/remote bkt. mount, str. design 3 ft cable				Y 50.9 x 12.7 [2.0 x 0.5] rubber	
			09 8.0 dBi omni w/remote bkt. mount, str. design 11 ft cable				T 19 x 8.76 [0.75 x 0.345] stainless steel	
			10 2.2 dBi omni w/remote mag. mount, tilt/swivel 10 ft cable					
			11 0 dBi omni w/switch mount; straight design					

NOTE: Not all combinations available. For further information on establishing any of the above listings, please contact Honeywell Sensing and Control or your local sales office.

WLS NOMENCLATURE

WLS	1	A	00	A	A	1	3
Switch type	Gen Code	RF Code	Antenna type code	Country use code	Operating head code	Actuator code	Modification code
WLS Series Wireless	1 Version 1	A 2.4 GHz; IEEE 802.15.4	00 No antenna; RP-SMA connector jack	A US, Canada, Mexico B All other approved countries ^{1, 2, 3}	A Side rotary, momentary C Top plunger, plain D Top plunger, roller E Side plunger, momentary J Wobble stick ⁴ N Side rotary, maintained V Top plunger, adjustable	See WLS actuator code table for details. Actuators for operating head code "A" only, insert actuator code from table below. OR Order actuator catalog listing separately for reduced delivery time.	Not applicable 3 Head assembled with actuator to right side 4 Head assembled with actuator to left side 5 Head assembled with actuator to mounting surface 6 Roller perpendicular to mounting surface
			01 2.2 dBi omni w/switch mount; straight design 02 2.2 dBi omni w/switch mount; tilt/swivel 03 3.0 dBi omni w/remote adhesive mount 9.8 ft cable 04 5.5 dBi omni w/remote mag. mount, tilt/swivel 5 ft cable 05 5.5 dBi omni w/remote mag. mount, tilt/swivel 10ft cable 06 9.0 dBi omni w/remote mag. mount, tilt/swivel 5 ft cable 07 9.0 dBi omni w/remote mag. mount, tilt/swivel 10ft cable 08 8.0 dBi omni w/remote bkt. mount, str. design 3 ft cable 09 8.0 dBi omni w/remote bkt. mount, str. design 11 ft cable 10 2.2 dBi omni w/remote mag. mount, tilt/swivel 10 ft cable 11 0 dBi omni w/switch mount; straight design	¹ Use with antenna type codes 00 - 03, 05, 10, 11 only; usage also allowed in Country Code A. ² Some countries require specific communication certifications. Contact Honeywell for existing certification information. ³ If Limitless devices are used on machinery that may shipped globally, use country code "B". ⁴ See page 14 for more detail.			

NOTE: Not all combinations available. For further information on establishing any of the above listings, please contact Honeywell Sensing and Control or your local sales office.

EXAMPLE: WLS1A01AA1A (ordered with lever included)
Limitless™ heavy-duty limit switch, 2.2 dBi straight antenna, momentary, standard lever with nylon roller

EXAMPLE: WLS1A01AA (order lever separately)
Limitless™ heavy-duty limit switch, 2.2 dBi straight antenna, momentary, LSZ51A (standard lever with nylon roller) ordered separately,

WLS SERIES ACTUATOR CODE TABLE (see page 9 for more detail)

Code	Catalog Listing	Material	Roller Dia. (in)	Roller Width (in)	Roller Mounting
Fixed 1.5 inch radius					
1		Rollerless	n/a	n/a	n/a
1A	LSZ51A	Nylon	0.75	0.25	Front
1B	LSZ51B	Steel	0.75	0.25	Front
1C	LSZ51C	Nylon	0.75	0.25	Back
1D	LSZ51D	Steel	0.75	0.25	Back
1F	LSZ51F	Nylon	1.0	0.520	Front
1G	LSZ51G	Nylon	1.5	0.25	Front
1J	LSZ51J	Nylon	1.0	0.520	Back
1L	LSZ51L	Ball bearing	0.75	0.25	Back
1M	LSZ51M	Nylon	0.75	1.25	Back
1N	LSZ51N	Steel	0.75	1.25	Front
1P	LSZ51P	Nylon	0.75	0.50	Front
Adjustable 1.5 in to 3.5 in radius					
2		Rollerless	n/a	n/a	n/a
2A	LSZ52A	Nylon	0.75	0.25	Back
2B	LSZ52B	Steel	0.75	0.25	Back
2C	LSZ52C	Nylon	0.75	0.25	Front
2D	LSZ52D	Steel	0.75	0.25	Front
2E	LSZ52E	Nylon	0.75	1.30	Front
2J	LSZ52J	Nylon	1.0	0.50	Front
2K	LSZ52K	Nylon	1.5	0.25	Front
2L	LSZ52L	Ball bearing	0.75	0.25	Front
2M	LSZ52M	Nylon	2.0	0.25	Front
2N	LSZ52N	Nylon	0.75	0.50	Front
Yoke – 1.5 in radius					
3A	LSZ53A	Nylon	0.75	0.25	Front/Back
3B	LSZ53B	Steel	0.75	0.25	Front/Back
3D	LSZ53D	Steel	0.75	0.25	Front/Front

Code	Catalog Listing	Material	Roller Dia. (in)	Roller Width (in)	Roller Mounting
Yoke – 1.5 in radius , continued					
3E	LSZ53E	Nylon	0.75	0.25	Back/Front
3M	LSZ53M	Nylon	0.75	1.25	Back/Front
3P	LSZ53P	Steel	0.75	0.25	Back/Back
3S	LSZ53S	Nylon	0.75	0.25	Back/Back
Rod					
4		Hub only	n/a	n/a	n/a
4M	LSZ54M	Alum, 5.5 in	n/a	n/a	n/a
4N	LSZ54N	Stainless, 13 in	n/a	n/a	n/a
4R	LSZ54R	Spring Wire, 12 in	n/a	n/a	n/a
4V	LSZ54V	Flex cable, 4.8 in	n/a	n/a	n/a
Offset – 1.5 in radius					
5		Rollerless	n/a	n/a	n/a
5A	LSZ55A	Nylon	0.75	0.25	Back
5B	LSZ55B	Steel	0.75	0.25	Back
5C	LSZ55C	Nylon	0.75	0.25	Front
5D	LSZ55D	Steel	0.75	0.25	Front
5E	LSZ55E	Nylon	0.75	0.50	Front
5K	LSZ55K	Nylon	1.5	0.25	Front
Wobble stick					
7A	LSZ1JGA	Delrin™ rod, 5.5	n/a	n/a	n/a
7M	LSZ1JGM	Spring wire, 13.0	n/a	n/a	n/a
7N	LSZ1JGN	Cable, 5.5 in.	n/a	n/a	n/a
Short fixed - 1.3 in radius					
9A	LSZ59A	Nylon	0.75	0.25	Front
9B	LSZ59B	Steel	0.75	0.25	Front
9C	LSZ59C	Nylon	0.75	0.25	Back
9D	LSZ59D	Steel	0.75	0.25	Back

Limitless™ Limit Switch Series

WGLA Series

Levers



GLZ51A
fixed rotary lever,
nylon roller, front



GLZ51B
fixed rotary lever,
steel roller, front



GLZ55A
fixed rotary offset
lever, nylon roller,
front



GLZ55B
fixed rotary offset
lever, steel roller, front



GLZ53A
yoke lever, nylon rollers,
front placement



GLZ53B
yoke lever, steel rollers,
front placement



GLZ52A
adj. lever,
nylon roller, back



GLZ52B
adj. lever,
steel roller, back



GLZ52C/D
adj. lever,
nylon & steel roller,
front



GLZ54J
adjustable rod,
200 mm aluminum



GLZ54K
adjustable rod,
140 mm aluminum



GLZ54N
adjustable rod,
318 mm stainless
steel

Limitless™ Limit Switch Series

WLS Series

Levers



LSZ51A
fixed rotary lever,
nylon roller, front



LSZ51B
fixed rotary lever,
steel roller, front



LSZ51C
fixed rotary lever,
nylon roller, back



LSZ51D
fixed rotary lever,
steel roller, back



LSZ55A
through D
offset lever,
front & back



LSZ60
one-way
roller lever



LSZ53A through D
yoke lever, nylon and steel rollers,
front and back placement



LSZ52A
through D
adj. lever, nylon &
steel, front/back



LSZ52J
adjustable lever,
1-inch nylon roller



LSZ52K
adjustable lever,
1.5-inch nylon roller



LSZ54M
5.5-inch
aluminum rod



LSZ61
6-inch
loop



LSZ54R
12-inch
spring wire



LSZ68
12-inch rod
with spring



LSZ54N
13-inch
stainless steel
rod

Limitless™ Limit Switch Series

WLS Heavy-Duty Limit Switch with Eyelet Pull

Limitless™ WLS Series Heavy Duty Wireless Limit Switches with an eyelet-pull operating head can be used to attach a rope, cable or chain. It also can be used on cranes as an anti-two-block (A2B) switch. The Limitless™ Series benefits remote monitoring applications where wiring or wire maintenance is not physically possible or economically feasible. Combining this greater flexibility with proven harsh-duty packaging can result in increased efficiencies and improved safety for machines, equipment, OEMs, and operators.

FEATURES

Wireless Design

- Radio (license-free and global): WPAN 802.15.4, 2.4 GHz, point-to-point
- FCC 15, IC, ACMA, ETSI, COFETEL, WPC, IDA, ANATEL, SRRC, and KCC
- Up to 1000 ft [305 m] line of sight communication range when used with a Limitless™ WPMM Series wireless monitor or WDRR Series receiver module (sold separately)
- Reliable, flexible, and secure wireless transmission
- Long-life standard replaceable battery
- Direct or remote mount antenna options

Mechanical Design

- IP67/IP68; NEMA 1, 4, 6, 6P, 12, 13
- Unique all-metal drive train
- Zinc head and body are phosphate treated and epoxy finished
- Tested to 750 lb of pull force
- Captive head and body screws

BENEFITS

- Enables presence/absence detection in remote parts of application/machinery, where wiring is an issue or not feasible
- Ability to reconfigure multiple switches that easily allows for adding, subtracting or relocating Limitless™ WLS switches
- Reduces installation/maintenance costs with no wires, conduit, strain relief, clips, connectors, or connection boxes
- Eliminates issues with wire connection integrity on moving equipment
- Consumes ultra-low power to prolong battery life



APPLICATIONS

- Cranes: A2B (anti-two block) switch
- Rope-pull: door activation switch
- Cable pull for production stop applications (e.g., quality, broken tool, maintenance, out of parts); not applicable to human safety-stop applications

*Some countries require specific communication certifications. Contact Honeywell for existing certification information.



WLS Series with Eyelet Pull

Product type	Limitless™ Wireless Heavy-Duty Limit Switches
Availability	Global, license-free bands
Operating characteristics	Operating force: 7 lb approx. or 18 lb approx.
Actuator type	Eyelet-pull operating head (pull eyelet in-line with shaft to prevent damage)
Housing material	Zinc head and body are phosphate treated and epoxy finished
Radio	WPAN 802.15.4; 2.4 GHz
Antenna type	RP-SMA jack for direct or remote mount antenna options; omni-directional
Signal range	In excess of 305 m [1000 ft] line-of-sight communication between Limitless™ switches and monitor/receiver when using 2.2 dBi integral antenna
Battery	3.6 Vdc Lithium Thionyl Chloride; 2/3 AA size (Est. life >1yr) Manufactured by Green Energy, part number ER14335M Manufactured by Honeywell, part number WBT1
Sealing	IP67/IP68; NEMA 1, 4, 6, 6P, 12, 13
EMC	Latest applicable standards: EN 300 328, V1.7.1; EN 61326-1 (2006); EN 301 489-1, V1.8.1; EN 301 489-17, V2.1.1
Shock	IEC 60068-2-27; half sine, 10 g, 6 mS, 3 axis
Vibration	IEC 60068-2-6; 10-500Hz w/ 0,35 mm peak-to-peak, 58-500 Hz- 5g
Operating temperature	-40 °C to 85 °C [-40 °F to 185 °F]
Agency approvals and standards	<ul style="list-style-type: none"> - FCC 15.247: United States of America - IC RSS 210: Canada - ETSI, CE mark: European countries - ACMA, C-TICK: Australia, New Zealand - IDA: Singapore - COFETEL: Mexico - WPC: India - ANATEL: Brazil - SRRC: China - KCC: South Korea

*Some countries require specific communication certifications.
Contact Honeywell for existing certification information.

Limitless™ Wireless Heavy-Duty Limit Switch with Eyelet Pull

Dimensions and Ordering Options

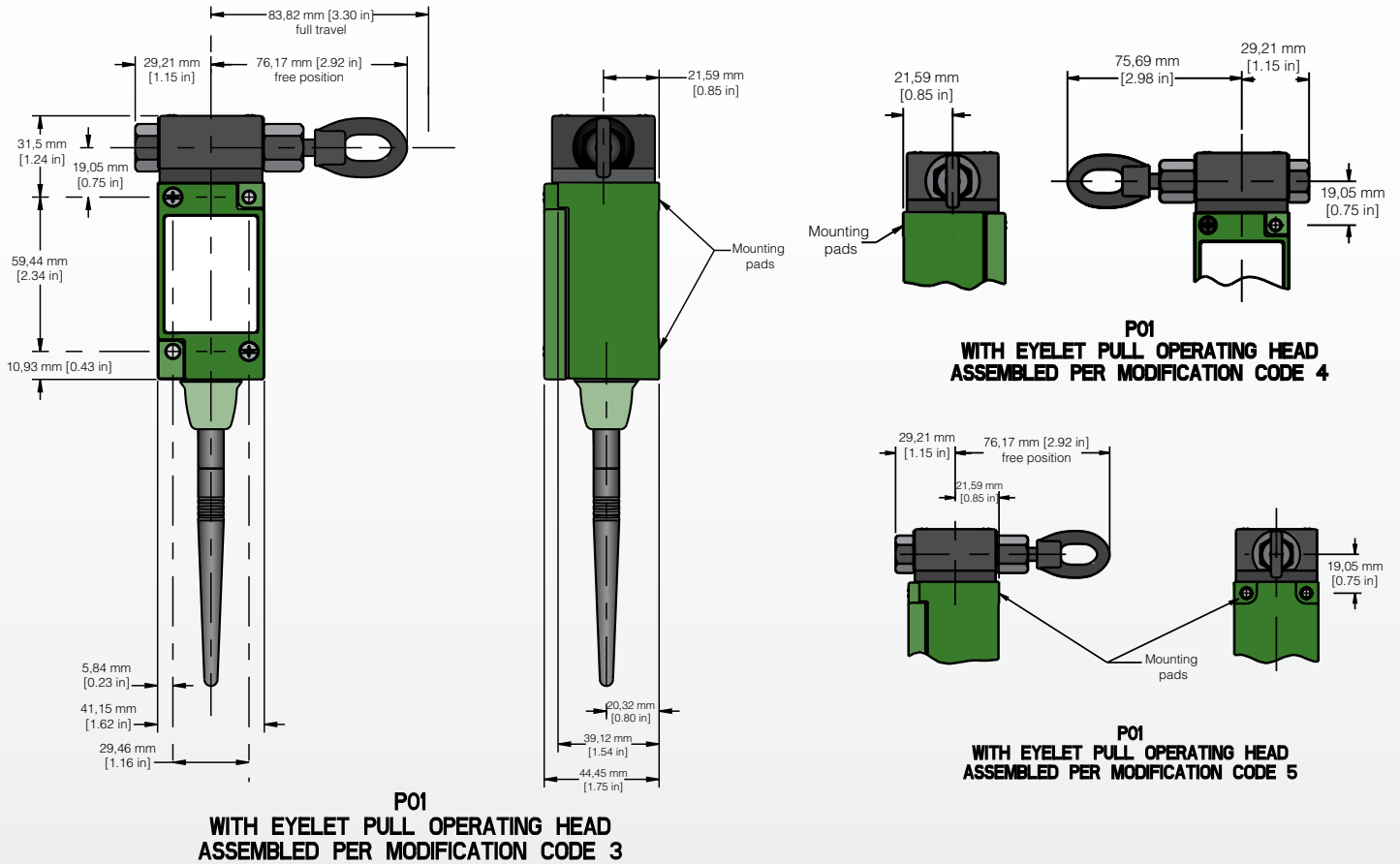

WLS WITH EYELET PULL NOMENCLATURE

WLS	1	A	00	A	A	-	3	P01
Switch type	Gen Code	RF Code	Antenna type code	Country use code	Operating head code	Modification code	Specials	
WLS Series Wireless	1 Version 1	A 2.4 GHz; IEEE 802.15.4	00 No antenna; RP-SMA connector jack	A US, Canada, Mexico	Q See specials	3 Head assembled with actuator towards nameplate surface	P01 Eyelet-pull operating head (low force, 7 lb ref.)	
			01 2.2 dBi omni w/switch mount; straight design	B All other approved countries ^{1, 2, 3}		4 Head assembled with actuator to right side	P02 Eyelet-pull operating head (high force, 18 lb ref.)	
			02 2.2 dBi omni w/switch mount; tilt/swivel	¹ Use with antenna type codes 00 - 03, 05, 10, 11 only; usage also allowed in Country Code A.		5 Head assembled with actuator to mounting surface		
			03 3.0 dBi omni w/remote adhesive mount 9.8 ft cable	² Some countries require specific communication certifications. Contact Honeywell for existing certification information.				
			04 5.5 dBi omni w/remote mag. mount, tilt/swivel 5 ft cable	³ If Limitless devices are used on machinery that may be shipped globally, use Country Code "B".				
			05 5.5 dBi omni w/remote mag. mount, tilt/swivel 10 ft cable					
			06 9.0 dBi omni w/remote mag. mount, tilt/swivel 5 ft cable					
			07 9.0 dBi omni w/remote mag. mount, tilt/swivel 10 ft cable					
			08 8.0 dBi omni w/remote bkt. mount, str. design 3 ft cable					
			09 8.0 dBi omni w/remote bkt. mount, str. design 11 ft cable					
			10 2.2 dBi omni w/remote mag. mount, tilt/swivel 10 ft cable					
			11 0 dBi omni w/switch mount; straight design					

NOTE: Not all combinations available. For further information on establishing any of the above listings, please contact Honeywell Sensing and Control or your local sales office.

Limitless™ Wireless Heavy-Duty Limit Switch with Eyelet Pull

Standard Listings

Limitless™ WLS Series with Eyelet Pull for use in US/Canada

WLS	1A11	A	Q-4P01	Limitless™ WLS Series heavy-duty limit switch with 7 lb low-force eyelet pull operating head, head assembled with actuator to left side, 0 dBi omni antenna
WLS	1A11	A	Q-P01	Limitless™ WLS Series heavy-duty limit switch with 7 lb low-force eyelet pull operating head, head assembled with actuator to label side, 0 dBi omni antenna
WLS	1A11	A	Q-P02	Limitless™ WLS Series heavy-duty limit switch with 18 lb high-force eyelet pull operating head, head assembled with actuator to label side, 0 dBi omni antenna

Limitless™ WLS Series with Eyelet Pull for use in all other approved countries

WLS	1A11	B	Q-4P01	Limitless™ WLS Series heavy-duty limit switch with 7 lb low-force eyelet pull operating head, head assembled with actuator to left side, 0 dBi omni antenna
WLS	1A11	B	Q-P01	Limitless™ WLS Series heavy-duty limit switch with 7 lb low-force eyelet pull operating head, head assembled with actuator to label side, 0 dBi omni antenna
WLS	1A11	B	Q-P02	Limitless™ WLS Series heavy-duty limit switch with 18 lb high-force eyelet pull operating head, head assembled with actuator to label side, 0 dBi omni antenna

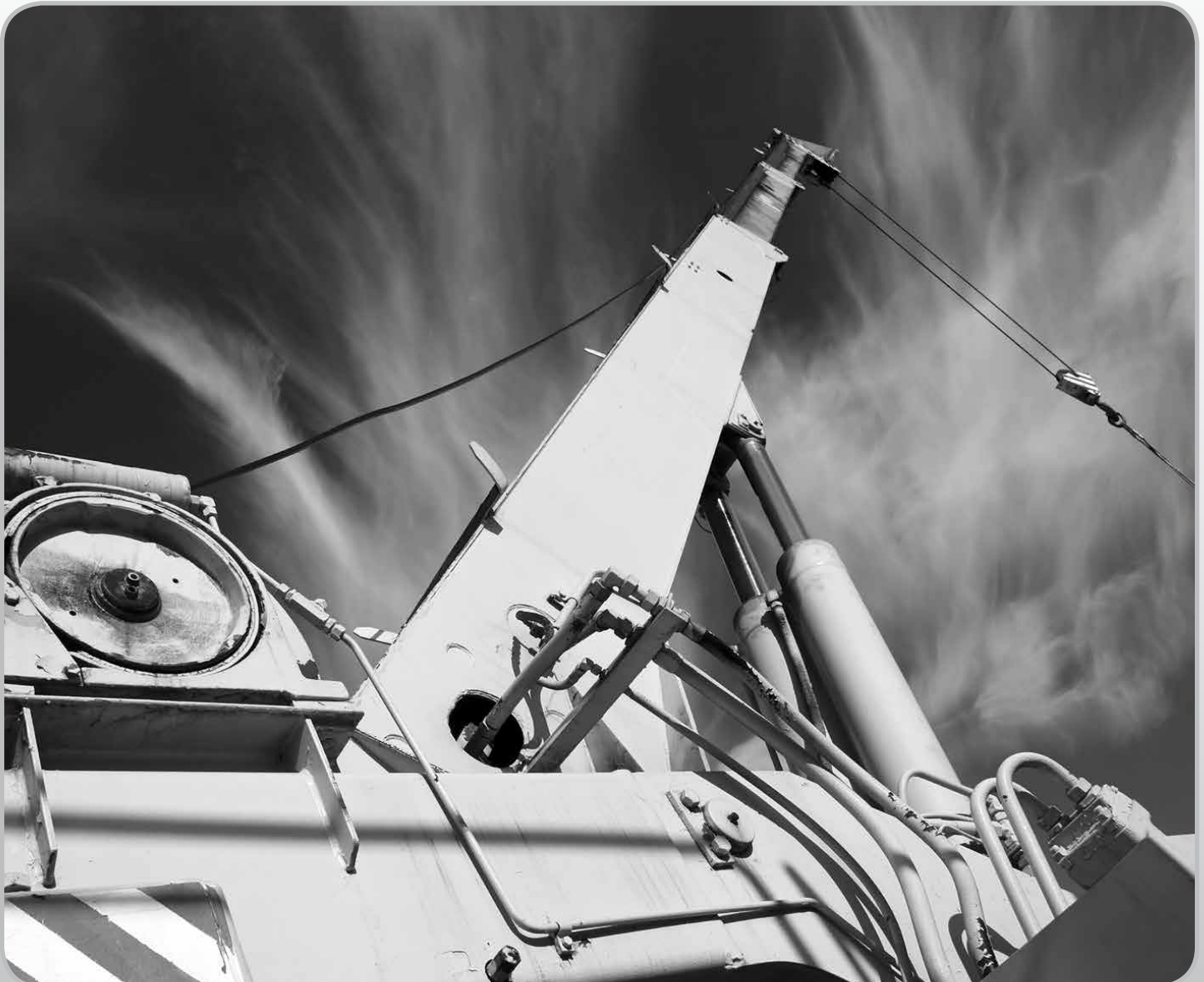

Limitless™ Limit Switch Series

WLS Heavy-Duty Limit Switch Single Switch Adapter

Honeywell's Limitless™ product line uses the latest commercial off-the-shelf wireless technology and has expanded the WLS Series to convert almost any electromechanical switch with low-energy contacts (i.e., gold) into a wireless switch. A user-supplied electromechanical switch is simply wired to the WLS Series Single Switch Adapter via the internal or external connections to then become a wireless-enabled switch for use with the Limitless™ WPMM or WDRR Series of monitors/receivers. The Limitless™ Single Switch Adapter can be used in a variety of industrial wireless limit switch applications such as reed, contact, pressure, door actuator, etc.

The Limitless™ Series is especially beneficial for remote monitoring applications where wiring or wire maintenance is not physically possible or economically feasible. Combining this greater flexibility with proven harsh-duty packaging can result in increased efficiencies and improved safety for machines, equipment, OEMs, and operators.

FEATURES

Wireless Design

- Radio (license-free and global): WPAN 802.15.4, 2.4 GHz, point-to-point
- FCC 15, IC, ACMA, ETSI, COFETEL, WPC & IDA
- Up to 305 m [1000 ft] line-of-sight communication range when used with a Limitless™ WPMM Series wireless monitor or WDRR Series receiver module (sold separately)
- Reliable, flexible, and secure wireless transmission
- Standard replaceable battery with ultra-low power consumption
- Direct or remote mount antenna options

Mechanical Design

- IP67; NEMA 1, 4, 12, 13
- 4 PIN M12 micro-change receptacle, cable grip with internal connector wiring options
- Internal battery power
- Body phosphate treated and epoxy finished with a 30 % glass-filled PBT plastic head

BENEFITS

- Allows almost any type of electromechanical switch with low-energy contacts (i.e., gold) to become "wireless"
- Enables presence/absence detection in remote parts of application/machinery, where wiring is an issue or not feasible
- Ability to reconfigure multiple switches, which easily allows for adding, subtracting or relocating of the Limitless™ WLS Single Switch Adapters
- Reduced installation/maintenance costs with no wires, conduit, strain relief, clips, connectors, connection boxes, etc.
- Eliminates issues with wire connection integrity on moving equipment
- Consumes ultra-low power to prolong battery life

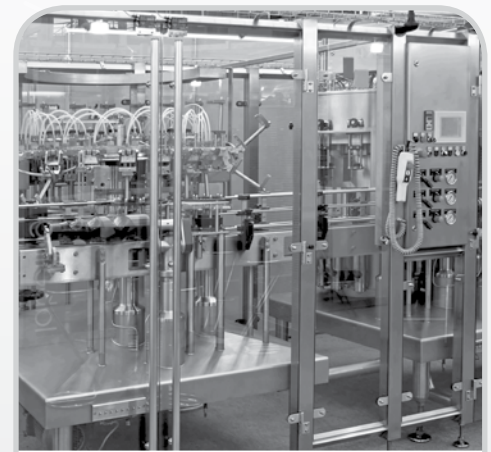

APPLICATIONS

- Agricultural equipment
- Construction equipment
- Door actuation (up/down) switch
- Industrial machines
- Lifts
- Machine tools
- Packaging machinery
- Wireless warehouse operations
- Wireless electromechanical switch applications (i.e., pressure switch, reed switch, basic switch and/or limit switch)

*Some countries require specific communication certifications. Contact Honeywell for existing certification information.



WLS Series Single Switch Adapter

Product type	Limitless™ Single Switch Adapter
Availability	Global, license-free bands
Housing material	Zinc body is phosphate treated and epoxy filled; 30 % glass-filled PBT plastic head
Radio	WPAN 802.15.4; 2.4 GHz
Antenna type	RP-SMA jack for direct or remote mount antenna options; omni directional standard
Signal range	Nominal 305 m [1000 ft] clear line of sight between Limitless™ switch and monitor/receiver when using 2.2 dBi integral antennas
Battery	3.6 Vdc Lithium Thionyl Chloride; 2/3 AA size (Est. life >1yr) Manufactured by Green Energy, part number ER14335M Manufactured by Honeywell, part number WBT1
Sealing	IP67, NEMA 1, 4, 12, 13
EMC	Latest applicable standards: EN 300 328, V1.7.1; EN 61326-1 (2006); EN 301 489-1, V1.8.1; EN 301 489-17, V2.1.1
Shock	IEC 60068-2-27; half sine, 50 g, 6 mS, 3 axis
Vibration	IEC 60068-2-6; 10-500Hz w/ 0,35 mm peak-to-peak, 58-500 Hz- 10g
Operating temperature	-40 °C to 85 °C [-40 °F to 185 °F]
Electromechanical switch	SPDT (Form C) switch with low-energy contacts (i.e., gold) capable of reliably controlling a 3.6 Vdc @ 30 mA electrical load to ensure proper operation
Electrical connections	<ul style="list-style-type: none"> • 4-pin M12 micro-connector with three-pole, single keyway female receptacle • Cable grip with internal screw connector Note: Maximum cable length 3 m [9.84 ft]
Communication Agency Approvals/Certificates*	- FCC 15.247: United States of America - IC RSS 210: Canada - COFETEL: Mexico - ETSI, CE mark: European countries - ACMA, C-TICK: Australia - IDA: Singapore - WPC: India

* Honeywell is continuing to add new Country Communication Agency Approvals as opportunities and requirements are established.

Limitless™ Single Switch Adapter

Dimensions and Ordering Options

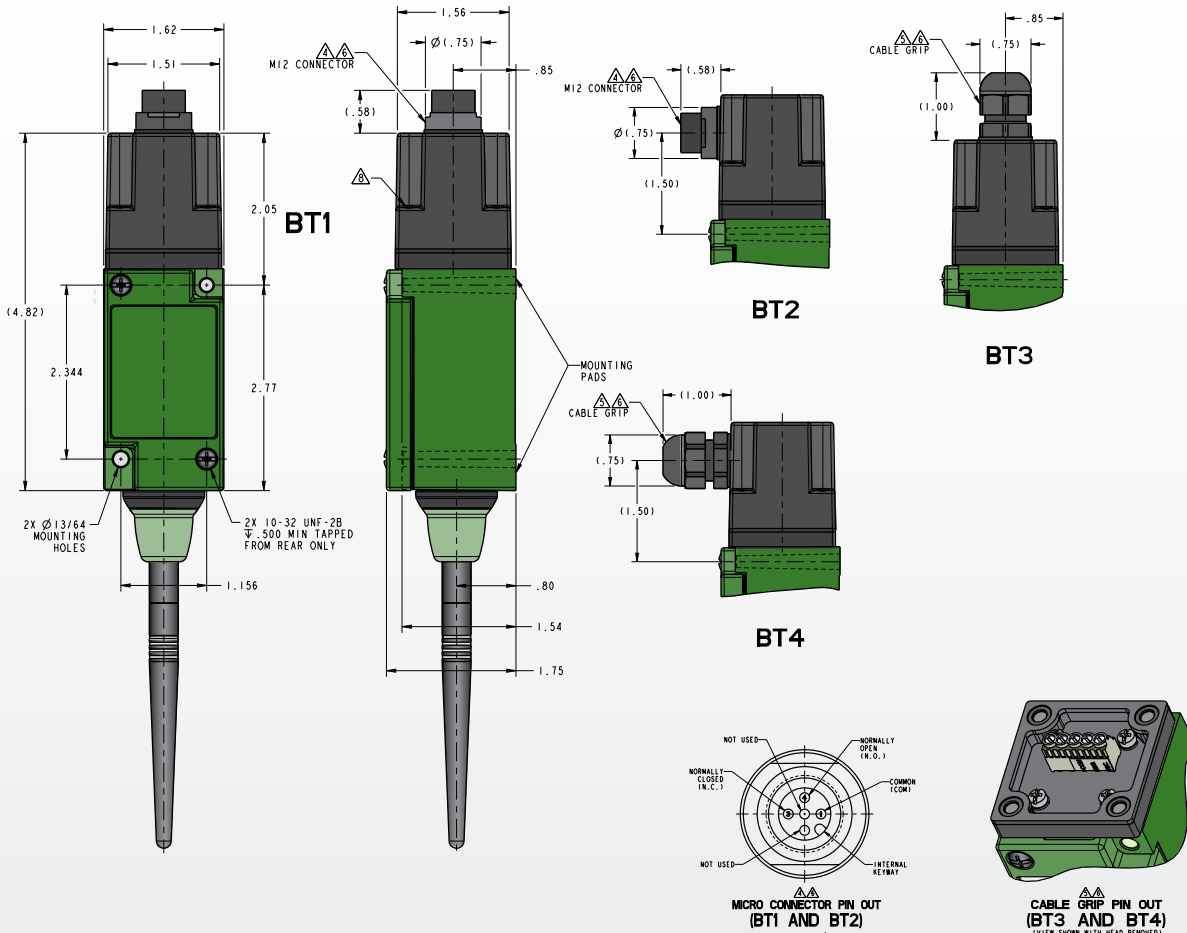

WLS SINGLE SWITCH ADAPTER NOMENCLATURE

WLS	1	A	00	A	Q		BT1
Switch type	Gen Code	RF Code	Antenna Type Code	Country Use Code	Operating Head Code	Modification Code (BT2 & BT4 only)	Specials
WLS Series Wireless	1 Version 1	A 2.4 GHz; IEEE 802.15.4	00 No antenna; RP-SMA connector jack 02 2.2 dBi omni w/switch mount; tilt/swivel 11 0 dBi omni w/switch mount; straight design	A US, Canada, Mexico B All other approved countries ^{1, 2, 3}	Q See specials	3 Head assembled with cable grip/connector to label side 4 Head assembled with cable grip/connector to right side 5 Head assembled with cable grip/connector to left side 5 Head assembled with cable grip/connector to mounting surface	BT1 Internal battery w/ micro-connector on top of head BT2 Internal battery w/ micro-connector on side of head BT3 Internal battery w/ cable grip on top of head BT4 Internal battery w/ cable grip on side of head

NOTE: Not all combinations available. For further information on establishing any of the above listings, please contact Honeywell Sensing and Control or your local sales office.

¹Use with antenna type codes 00 - 03, 05, 10, 11 only; usage also allowed in Country Code A.
²Some countries require specific communication certifications. Contact Honeywell for existing certification information.
³If Limitless devices are used on machinery that may shipped globally, use country code "B".

Limitless™ Single Switch Adapter

Standard Listings

Limitless™ Single Switch Adapter for use in US/Canada

M12 Connector

WLS	1A00	A	QBT1	Limitless™ WLS Series Single Switch Adapter, no antenna, internal battery with M12 micro-connector on top of head
WLS	1A02	A	QBT1	Limitless™ WLS Series Single Switch Adapter, 2.2 dBi tilt/swivel antenna, internal battery with M12 micro-connector on top of head
WLS	1A11	A	QBT1	Limitless™ WLS Series Single Switch Adapter, 0 dBi straight antenna, internal battery with M12 micro-connector on top of head

Cable Grip

WLS	1A00	A	QBT3	Limitless™ WLS Series Single Switch Adapter, no antenna, internal battery with cable grip on top of head
WLS	1A02	A	QBT3	Limitless™ WLS Series Single Switch Adapter, 2.2 dBi tilt/swivel antenna, internal battery with cable grip on top of head
WLS	1A11	A	QBT3	Limitless™ WLS Series Single Switch Adapter, 0 dBi straight antenna, internal battery with cable grip on top of head

Limitless™ Single Switch Adapter for use in all other approved countries

M12 Connector

WLS	1A00	B	QBT1	Limitless™ WLS Series Single Switch Adapter, no antenna, internal battery with M12 micro-connector on top of head
WLS	1A02	B	QBT1	Limitless™ WLS Series Single Switch Adapter, 2.2 dBi tilt/swivel antenna, internal battery with M12 micro-connector on top of head
WLS	1A11	B	QBT1	Limitless™ WLS Series Single Switch Adapter, 0 dBi straight antenna, internal battery with M12 micro-connector on top of head

Cable Grip

WLS	1A00	B	QBT3	Limitless™ WLS Series Single Switch Adapter, no antenna, internal battery with cable grip on top of head
WLS	1A02	B	QBT3	Limitless™ WLS Series Single Switch Adapter, 2.2 dBi tilt/swivel antenna, internal battery with cable grip on top of head
WLS	1A11	B	QBT3	Limitless™ WLS Series Single Switch Adapter, 0 dBi straight antenna, internal battery with cable grip on top of head



Limitless™ Limit Switch Series

WLS Series

Wireless Non-Contact Switch

Honeywell's Limitless™ product line uses the latest commercial off-the-shelf wireless technology. The Limitless™ WLS Series is especially beneficial for remote monitoring applications where wiring or wire maintenance is not physically possible or economically feasible. Honeywell has expanded the Limitless™ product line with its industrial Wireless Non-Contact Switch that provides non-contact presence/absence detection of a variety of different magnet styles and magnetic actuators installed on the end-users' product, machine, equipment, etc. The Limitless™ WLS Non-Contact Switch's design features an industrial grade reed switch. Customers can choose how the reed switch is oriented within the switch's plastic head, i.e., either top- or side-sensing. Combining this greater flexibility with proven harsh-duty packaging can result in increased efficiencies and improved safety for industrial machines, equipment, OEMs, and operators.

FEATURES

Wireless Design

- Radio (license-free and global): WPAN 802.15.4, 2.4 GHz, point-to-point
- FCC 15, IC, ACMA, ETSI, COFETEL, WPC & IDA
- Up to 305 m [1000 ft] line-of-sight communication range when used with a Limitless™ wireless monitor or receiver module (sold separately)
- Reliable, flexible, and secure wireless transmission
- Replaceable battery with ultra-low power consumption
- Direct or remote mount antenna options

Mechanical Design

- IP67; NEMA 1, 4, 12, 13
- Top and side sensing heads
- Zinc head and body are phosphate treated and epoxy finished

BENEFITS

- Allows "non-contact" actuation
- Enables presence/absence detection in remote parts of application/machinery, where wiring is an issue or not feasible
- Able to reconfigure and network multiple switches, or point-to-point with personalized addresses, which allows for adding, subtracting or relocating of the Limitless™ WLS Non-Contact Switches
- Reduced installation/maintenance costs with no wires, conduit, strain relief, clips, connectors, connection boxes, etc.
- Eliminates issues with wire connection integrity on moving equipment
- Consumes ultra-low power to prolong battery life

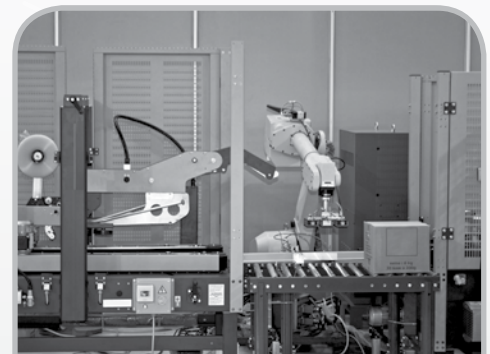

APPLICATIONS

- Machine tools
- Packaging machinery
- Lifts
- Ag/construction equipment
- Industrial machines

*Some countries require specific communication certifications. Contact Honeywell for existing certification information.



WLS Series Wireless Non-Contact Switch

Product type	Limitless™ Wireless Non-Contact Switch
Availability	Global, license-free bands
Operating characteristics	Operating point: 3,81 mm [0.15 in] min.; Release point: 15,24 mm [0.60 in] max. with use of WMG1 magnet (included with WLS Series Non-Contact Switch)
Sensing target	Top and side of head
Housing material	Zinc head and body are phosphate treated and epoxy finished; 30% glass-filled PBT plastic head
Radio	WPAN 802.15.4; 2.4 GHz
Antenna type	RP-SMA jack for direct or remote mount antenna options; omni directional standard
Signal range	Nominal 305 m [1000 ft] Clear line-of-sight between Limitless™ switch and monitor/receiver when using 2.2 dBi integral antenna
Battery	3.6 Vdc Lithium Thionyl Chloride; 2/3 AA size (Est. life >1yr) Manufactured by Green Energy, part number ER14335M; Manufactured by Honeywell, part number WBT1
Sealing	IP67; NEMA 1, 4, 12, 13
EMC	Latest applicable standards: EN 300 328, V1.7.1; EN 61326-1 (2006); EN 301 489-1, V1.8.1; EN 301 489-17, V2.1.1
Shock	EC 60068-2-27; half sine, 10 g, 6 mS, 3 axis
Vibration	IEC 60068-2-6; 10-58 Hz w/ 0,35 mm peak-to-peak - 5g
Operating temperature	-40 to 85 °C [-40 °F to 185 °F]
Communication Agency Approvals/ Certificates*	- FCC 15.247: United States of America - IC RSS 210: Canada - COFETEL: Mexico - ETSI, CE mark: European countries - ACMA, C-TICK: Australia - IDA: Singapore - WPC: India

* Honeywell is continuing to add new Country Communication Agency Approvals as opportunities and requirements are established

*Some countries require specific communication certifications.
Contact Honeywell for existing certification information.

Limitless™ Wireless Non-Contact Switch

Dimensions and Ordering Options

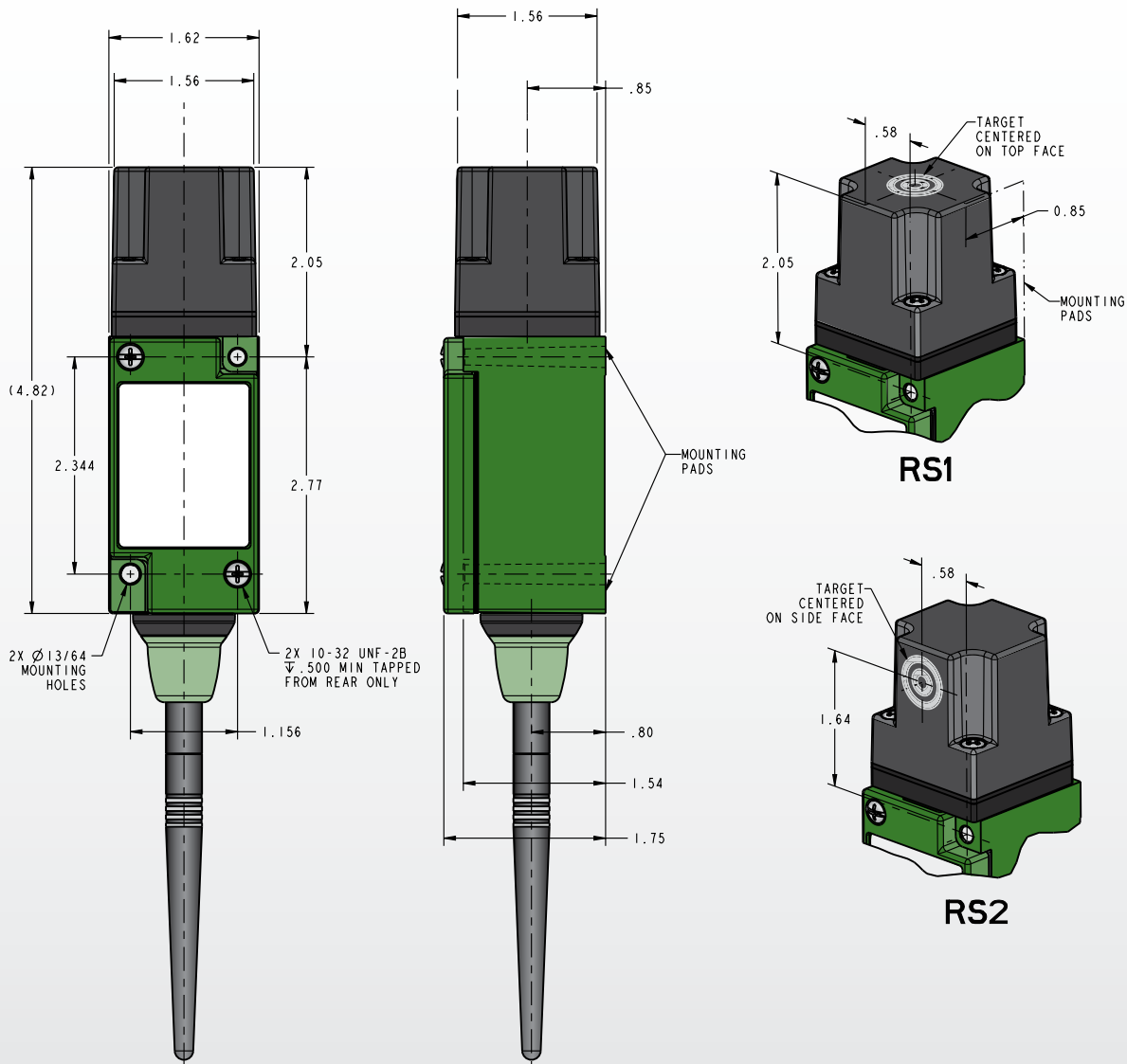

WLS SERIES NON-CONTACT SWITCH NOMENCLATURE

WLS	1	A	00	A	Q		RS2
Switch Type	Gen Code	RF Code	Antenna Type Code	Country Use Code	Operating Head Code	Modification Code (RS2 only)	Specials
WLS Series Wireless	1 Version 1	A 2.4 GHz; IEEE 802.15.4	00 No antenna; RP-SMA connector jack 02 2.2 dBi omni w/switch mount; tilt/swivel 11 0 dBi omni w/ switch mount; straight design	A US, Canada, Mexico B All other approved countries ^{1, 2, 3}	Q See specials	3 Head assembled with target to label side 4 Head assembled with target to right side 5 Head assembled with target to left side 5 Head assembled with target to mounting surface	RS1 Internal battery w/ reed switch target on top of head RS2 Internal battery w/ reed switch target on side of head

NOTE: Not all combinations available.
For further information on establishing any of the above listings, please contact Honeywell Sensing and Control or your local sales office.

²Some countries require specific communication certifications. Contact Honeywell for existing certification information.

³If Limitless devices are used on machinery that may shipped globally, use country code "B".

Limitless™ Wireless Non-Contact Switch

Standard Listings

Limitless™ Wireless Non-Contact Switch for use in US/Canada

Top Sensing

WLS	1A00	A	QRS1	Limitless™ WLS Series Non-Contact Switch with no antenna and a top sensing target
WLS	1A11	A	QRS1	Limitless™ WLS Series Non-Contact Switch with a 0 dBi antenna and a top sensing target

Side Sensing

WLS	1A00	A	QRS2	Limitless™ WLS Series Non-Contact Switch with no antenna and a side sensing target
WLS	1A11	A	QRS2	Limitless™ WLS Series Non-Contact Switch with a 0 dBi antenna and a side sensing target

Limitless™ Wireless Non-Contact Switch for use in all other approved countries

Top Sensing

WLS	1A00	B	QRS1	Limitless™ WLS Series Non-Contact Switch with no antenna and a top sensing target
WLS	1A11	B	QRS1	Limitless™ WLS Series Non-Contact Switch with a 0 dBi antenna and a top sensing target

Side Sensing

WLS	1A00	B	QRS2	Limitless™ WLS Series Non-Contact Switch with no antenna and a side sensing target
WLS	1A11	B	QRS2	Limitless™ WLS Series Non-Contact Switch with a 0 dBi antenna and a side sensing target



Limitless™ Wireless Operator Interface

WOI Series

The Limitless™ product line extends to include wireless operator interface. With both momentary and maintained contacts, the wireless operator interface (WOI) can be used by an operator to provide indication via a pushbutton or another user-chosen operator type (i.e. 22 mm rotary switch, 22 mm key switch, etc.). The WOI Series adds a human interface device to the product-driven interfaces of Limitless™ switches and receivers – wireless control from both person and position.

The WOI Series is especially beneficial for remote monitoring applications where wiring or wire maintenance is not physically possible or economically feasible. Combining this greater flexibility with proven harsh-duty packaging can result in increased efficiencies and ease in establishing a remote operator for use in a variety of applications, including turning equipment or devices on or off, opening and closing doors/gates, stopping a production conveyor, indicating the need for service, and much more.

FEATURES

Wireless Design

- Radio (license-free and global): WPAN 802.15.4, 2.4 GHz, point-to-point
- FCC 15, IC, ACMA & ETSI
- RoHS compliant
- EMI immunity
- Up to 305 m [1000 ft] communication range when used with a Limitless™ wireless monitor or receiver module (sold separately)
- Reliable, flexible, and secure wireless transmission
- Standard replaceable battery with ultra-low power consumption
- Direct or remote mount antenna options

Mechanical Design

- Aluminum enclosure
- IP65 sealing
- 22 mm flush, 29 mm mushroom, & 40 mm mushroom (push-pull) round pushbutton operators available
- User chosen/installed operator type is allowable
- Momentary and maintained contact options
- Design for ease of installation

BENEFITS

- Enables operator indication (i.e. push button) from remote locations where wiring is too costly or not possible
- Flexibility for users to choose and install their desired operator type; i.e. 22 mm rotary switch, 22 mm key switch, etc.
- Ability to reconfigure and network multiple WOI inputs, or point-to-point with personalized addresses, which allows for adding, subtracting or re-locating of Limitless™ WOI switches easily
- Offers the ability to be used in conjunction with Limitless™ switches configured on a single Limitless™ receiver
- Reduced installation/maintenance costs with no wires, conduit, strain relief, clips, connectors, connection boxes, etc.
- Eliminates issues with wire connection integrity on moving equipment
- Consumes ultra-low power to prolong battery life



APPLICATIONS

Industrial

- CNC action
- Conveyors
- Door/Gate action
- Lifts
- Material handling
- Motor drives
- Presses
- Pumps
- Quality control buttons
- Specialty machines
- Stop/Start machinery
- Stop/Start production
- Valve action

Transportation

- Agricultural equipment
- Movable machinery



WOI Series

Product type	Limitless™ Operator Interface Switches
Availability	Global, license-free bands
Operating force	Momentary pushbutton: 6,2 N ±2 N [1.4 lb ±0.45 lb] Maintained pushbutton: 7,0 N ±2 N [1.6 lb ±0.45 lb]
Actuator type	Pushbutton operators <ul style="list-style-type: none"> • 22 mm round flush momentary • 29 mm mushroom head momentary • 40 mm mushroom head maintained (push-pull); No operator option available for use with user supplied 22 mm operator and contact blocks
Actuator/contact blocks (if user supplied)	22 mm switch design (i.e. 22mm rotary switch, 22mm key switch, etc.) /gold contact, normally open and normally closed contact blocks capable of reliably controlling a 30 mA @ 3.6 Vdc electrical load
Actuator colors	Black, Green, Red*, Yellow * not available for the 29 mm mushroom, & 40 mm mushroom (push-pull) pushbuttons
Housing material	Powder coated aluminum
Radio	WPAN 802.15.4; 2.4 GHz
Antenna type	Direct or remote mount antenna options; Omni directional
Signal range	Nominal 305 m [1000 ft] clear line of sight between Limitless™ WOI switch and monitor/receiver when using 2.2 dBi integral antennas
Battery	3.6 Vdc Lithium Thionyl Chloride; 2/3 AA size (Est. life >1.5 years) Manufactured by Green Energy p/n ER14335M; Manufactured by Honeywell, part number WBT1
Sealing	IP65
EMC	Latest applicable standards: EN 300 328, V1.7.1; EN 61326-1 (2006); EN 301 489-1, V1.8.1; EN 301 489-17, V2.1.1
Shock	IEC 60068-2-27; half sine, 50 g, 6 mS, 3 axis
Vibration	IEC 60068-2-6; 10-500Hz w/ 0,35 mm peak-to-peak, 58-500 Hz- 10g
Operating temperature	-25 °C to 50 °C [-13 °F to 122 °F]
Agency approvals and standards	FCC 15.247 Industry Canada RSS 210 ETSI, CE mark ACMA, C-Tick mark

Limitless™ Wireless Operator Interface

Dimensions and Ordering Options

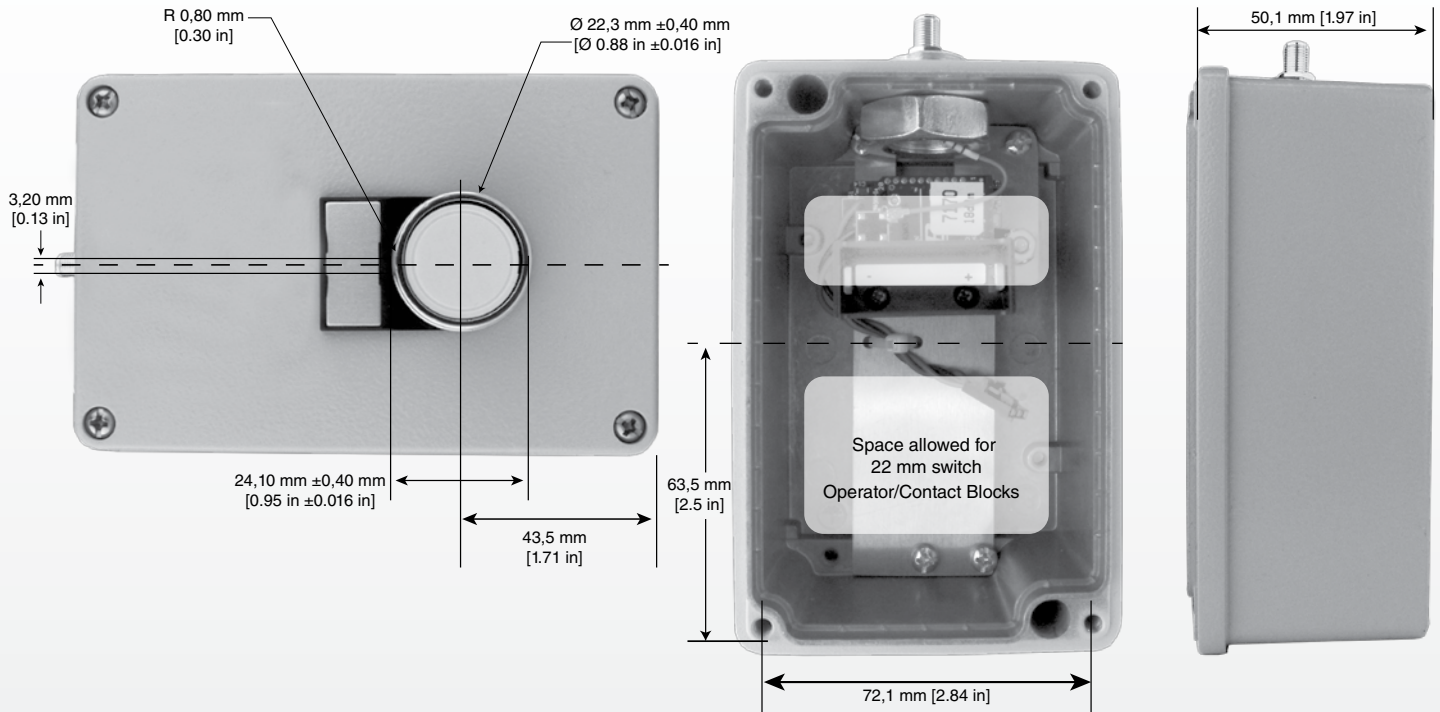

WOI NOMENCLATURE

WOI	1	A	00	A	PA	G
Module type	GEN code	RF code	Antenna type code	Country use code	Actuator type	Actuator color
WOI Series Operator Interface	1 Version 1	A 2.4 GHz; IEEE 802.15.4	00 No antenna; RP-SMA connector jack	A US, Canada Mexico	None; open hole in enclosure	None
			02 2.2 dBi omni w/switch mount; tilt/swivel	B All other approved countries ^{1,2}	PA Pushbutton only 22 mm round flush button, momentary	B Black
			11 0 dBi omni w/ switch mount; str. design	¹ Some countries require specific communication certifications. Contact Honeywell for existing certification information.	PB Pushbutton only ³ 29 mm mushroom head, momentary	G Green
				² If Limitless™ devices are used on machinery that may be shipped globally, use Country Code "B".	PC Pushbutton only ³ 40 mm mushroom head, maintained/push-pull	R Red
					³ NOT AVAILABLE IN RED	Y Yellow

NOTE: Not all combinations available. For further information on establishing any of the above listings, please contact Honeywell Sensing and Control or your local sales office.

Limitless™ Wireless Operator Interface

WOI Standard Listings

Limitless™ WOI Series Operator Interface for use in US/Canada

22 mm flush pushbutton

WOI	1A00	A	PAG	Limitless™ WOI, no antenna, 22 mm round flush momentary green pushbutton
WOI	1A00	A	PAR	Limitless™ WOI, no antenna, 22 mm round flush momentary red pushbutton
WOI	1A11	A	PAG	Limitless™ WOI, 0 dBi straight antenna, 22 mm round flush momentary green pushbutton
WOI	1A11	A	PAR	Limitless™ WOI, 0 dBi straight antenna, 22 mm round flush momentary red pushbutton

29 mm mushroom pushbutton

WOI	1A00	A	PBY	Limitless™ WOI, no antenna, 29 mm mushroom head momentary yellow pushbutton
WOI	1A11	A	PBY	Limitless™ WOI, 0 dBi straight antenna, 29 mm mushroom head momentary yellow pushbutton

40 mm maintained pushbutton

WOI	1A00	A	PCY	Limitless™ WOI, no antenna, 40 mm maintained yellow pushbutton
WOI	1A11	A	PCY	Limitless™ WOI, 0 dBi straight antenna, 40 mm maintained yellow pushbutton

Limitless™ WOI Series Operator Interface for use in all other approved countries

22 mm flush pushbutton

WOI	1A00	B	PAG	Limitless™ WOI, no antenna, 22 mm round flush momentary green pushbutton
WOI	1A00	B	PAR	Limitless™ WOI, no antenna, 22 mm round flush momentary red pushbutton
WOI	1A11	B	PAG	Limitless™ WOI, 0 dBi straight antenna, 22 mm round flush momentary green pushbutton
WOI	1A11	B	PAR	Limitless™ WOI, 0 dBi straight antenna, 22 mm round flush momentary red pushbutton

29 mm mushroom pushbutton

WOI	1A00	B	PBY	Limitless™ WOI, no antenna, 29 mm mushroom head momentary yellow pushbutton
WOI	1A11	B	PBY	Limitless™ WOI, 0 dBi straight antenna, 29 mm mushroom head momentary yellow pushbutton

40 mm maintained pushbutton

WOI	1A00	B	PCY	Limitless™ WOI, no antenna, 40 mm maintained yellow pushbutton
WOI	1A11	B	PCY	Limitless™ WOI, 0 dBi straight antenna, 40 mm maintained yellow pushbutton



Limitless™ Monitor and Receiver

WPMM Wireless Panel-Mount Monitor

WDRR Wireless DIN-Rail Receiver

Limitless™ WPMM Series wireless panel-mount monitors provide a visual, audio, and output based on a signal received from a Limitless™ input. Limitless™ WPMM monitors offer quick indication of an actuator position change on a paired Limitless™ wireless limit switch.

The WDRR Series DIN-Rail receiver accommodates up to 14 Limitless™ digital inputs for applications that need more than one-input/one-receiver configuration. It provides a separate visual and selectable NPN- or PNP-type output for indication of a change on a Limitless™ input.

WPMM FEATURES

Wireless Electrical Design

- Radio (license-free and global*): WPAN 802.15.4, 2.4 GHz, point-to-point
- FCC 15, IC, ACMA, ETSI, COFETEL, IDA, WPC, SRRC, KCC, and ANATEL
- RoHS compliant
- EMI resistance protects against external interference
- In excess of 305 m [1000 ft] line-of-sight communication
- Reliable, flexible, and secure wireless transmission
- 10 Vdc to 30 Vdc supply
- Three output options: NPN normally open current sinking, PNP normally open current sourcing, and solid state relay
- Diagnostic functions include lost RF and low battery indication
- Designed primarily for single switch applications, but can monitor multiple wireless switches (*sold separately*)
- Field pairing function allows for rapid configuration

Mechanical Design

- Panel-mount enclosure (snap-in or screw mount)
- Polycarbonate, shock resistant, tamper-proof case
- Sealed to IP67
- Multiple LED function/status indicators with audible buzzer (configurable to silent)
- Direct or remote-mount antenna

WDRR FEATURES

Wireless Electrical Design

- Selectable NPN-, PNP-, or totem-pole- type output
- Fourteen configurable normally open or normally closed outputs for up to 14 Limitless™ inputs (*sold separately*)
- Reliable, flexible, and secure wireless transmission
- Radio (license-free and global*): WPAN 802.15.4, 2.4 GHz, point-to-point
- In excess of 305 m [1000 ft] line-of-sight communication between Limitless™ switches and monitor/receiver when using 2.2dBi integral antenna
- FCC 15, IC, ACMA, ETSI, COFETEL, IDA, WPC, SRRC, KCC, and ANATEL
- RoHS compliant
- Field pairing allows for rapid adding or subtracting inputs for quick configuration
- 10 Vdc to 28 Vdc supply
- Diagnostic functions include lost RF and low battery indication

Mechanical Design

- DIN Rail or screw mount
- Cage clamp screw terminal blocks for input/output connections
- Sealed to IP20
- Multiple LED function and status indicators
- LED RF signal strength indication for up to 14 Limitless™ inputs
- Direct or remote mount antenna

LIMITLESS™ SERIES BENEFITS

- Ability to reconfigure and network multiple switches, or point-to-point with personalized addresses that allow for adding, subtracting or relocating Limitless™ switches easily
- Reduced installation/maintenance costs with no wiring, conduit, strain relief, clips, connectors, connection boxes, etc.
- Communication security per the IEEE 802.15.4 standard [16-bit PAN (network) ID, 16-bit address and 128-bit security key]
- Eliminates issues with wire and connector integrity on moving equipment



APPLICATIONS

- Construction/ag machines
- Conveyors
- Crane boom/jib/skew position
- Door position
- Grain diverters or flaps
- Hose attachment verification
- Lifts
- Material handling
- Movable machinery
- Presses
- Remote or temporary equipment
- Specialty machines
- Valve position

*Some countries require specific communication certifications. Contact Honeywell for existing certification information.



WPMM Series

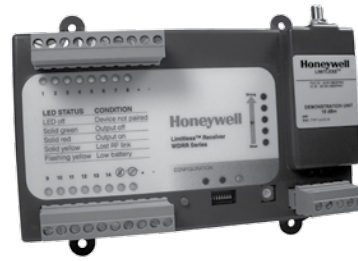

WDRR Series

Limitless™ wireless panel mount monitor	Product type	Limitless™ wireless din-rail receiver (PLC interface)
WPMM Series	Series name	WDRR Series
Global, license-free RF bands*	Availability	Global, license-free RF bands*
LCP, VECTRA E130i	Housing material	Flame retardant ABS
Snap-in panel or screw-mount design	Housing type	DIN-Rail or screw-mount design
WPAN 802.15.4, 2.4 GHz point to point	Radio type	WPAN 802.15.4, 2.4 GHz point-to-point
RP-SMA jack for direct mount or remote antenna options; omni-directional standard	Antenna type	RP-SMA jack for direct mount or remote antenna options; omni-directional standard
In excess of 305 m [1000 ft] line-of-sight communication between Limitless™ switches and monitor/receiver when using 2.2 dBi integral antenna	Signal range	In excess of 305 m [1000 ft] line-of-sight communication between Limitless™ switches and monitor/receiver when using 2.2 dBi integral antenna
Three LEDs: green, yellow, red Power indication: green Output indication: red Configuration/diagnostic: green, yellow, red Buzzer (output indic, config/diag) w/ silent option	Indication	Configuration LEDs: green, yellow, red 14 output/diagnostic LEDs: green, yellow, red Low battery & lost RF output LEDs: red, green RF signal strength LEDs: blue
10 Vdc to 30 Vdc	Supply voltage	10 Vdc to 28 Vdc
750 mA max.	Supply current	500 mA max.
NPN normally open current sinking; PNP normally open current sourcing; solid state relay	Output type	Selectable: NPN-type current sinking open collector or NPN-type “totem pole”; PNP-type current sourcing open collector or PNP-type “totem pole”
5 mA to 200 mA	Load current	10 mA max.
50 uA max.	Leakage current	100 uA max.
1.75 Vdc max. @ max. load @ 25 °C [77 °F]	Voltage drop	2.0 Vdc max. @ max. load @ 25 °C [77 °F]
3	Terminal(s)	18 usable
Quick connect, 0.25 in male blade	Termination	Cage-clamp screw terminal blocks
IP67	Sealing	IP20
Yes	Reverse polarity protection	Yes
Latest applicable standards: EN 300 328, V1.7.1; EN 61326-1 (2006); EN 301 489-1, V1.8.1; EN 301 489-17, V2.1.1	EMC	Latest applicable standards: EN 300 328, V1.7.1; EN 61326-1 (2006); EN 301 489-1, V1.8.1; EN 301 489-17, V2.1.1
IEC 60068-2-27; half sine, 10 g, 6 mS, 3 axis	Shock	IEC 60068-2-27; Half sine, 10 g, 6 mS, 3 axis
IEC 60068-2-6; 10 Hz to 500 Hz w/ 0,35 mm peak-to-peak, 58 Hz to 500 Hz- 5 g	Vibration	IEC 60068-2-6; 10-500Hz w/ 0,35 mm peak-to-peak, 58-500 Hz- 5 g
-40 °C to 85 °C [-40 °F to 185 °F]	Operating temp.	-20 °C to 70 °C [-4 °F to 158 °F]
FCC 15.247; IC RSS 210, ETSI, CE mark; ACMA, C-TICK; COFETEL; IDA; ANATEL; WPC; SRRRC; KCC	Agency approvals and standards	FCC 15.247; IC RSS 210, ETSI, CE mark; ACMA, C-TICK; COFETEL; IDA; ANATEL; WPC; SRRRC; KCC
31,87 mm H x 44,40 mm W x 74,30 mm D [1.25 in H x 1.748 in W x 2.925 in D] ref.	Size	88,9 mm H x 152,4 mm W x 38,1 mm D [3.5 in H x 6 in W x 1.5 in D] ref.

*Some countries require specific communication certifications.
Contact Honeywell for existing certification information.

Limitless™ Monitor

WPMM Wireless Panel-Mount Monitor Dimensions and Ordering Options

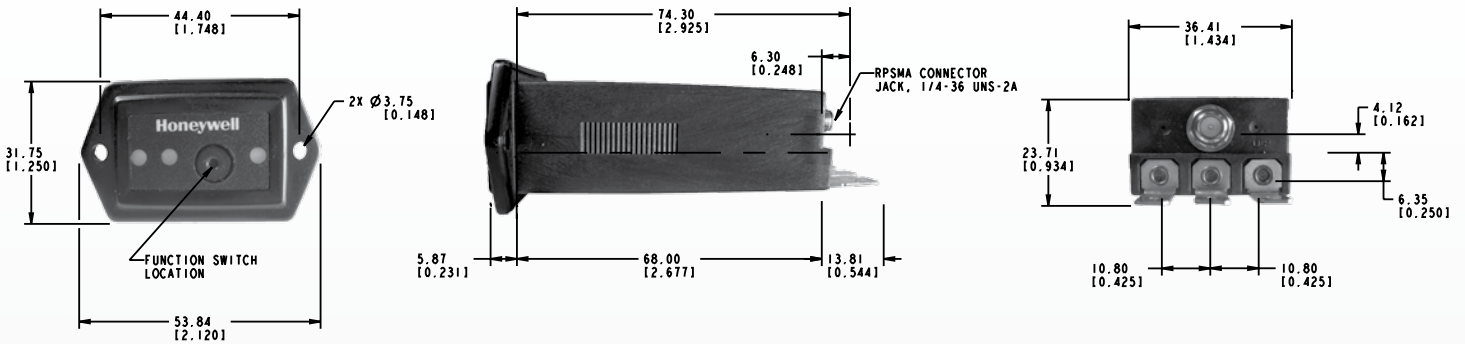

All dimensions for reference only.

WPMM NOMENCLATURE

WPMM	1	A	00	A	P01
Switch type	Gen Code	RF Code	Antenna type code	Country use code	Specials
WPMM Series Monitor	1 Version 1	A 2.4 GHz; IEEE 802.15.4	00 No antenna; RP-SMA connector jack	A US, Canada, Mexico	None/NPN output
			01 2.2 dBi omni w/switch mount; straight design	B All other approved countries ^{1, 2, 3}	P01 PNP output
			02 2.2 dBi omni w/switch mount; tilt/swivel	¹ Use with antenna type codes 00 - 03, 05, 10, 11 only; usage also allowed in Country Code A.	S01 Solid state relay output
			03 3.0 dBi omni w/remote adhesive mount 9.8 ft cable	² Some countries require specific communication certifications. Contact Honeywell for existing certification information.	
			04 5.5 dBi omni w/remote mag. mount, tilt/swivel 5 ft cable	³ If Limitless™ devices are used on machinery that may be shipped globally, use Country Code "B".	
			05 5.5 dBi omni w/remote mag. mount, tilt/swivel 10 ft cable		
			06 9.0 dBi omni w/remote mag. mount, tilt/swivel 5 ft cable		
			07 9.0 dBi omni w/remote mag. mount, tilt/swivel 10 ft cable		
			08 8.0 dBi omni w/remote bkt. mount, str. design 3 ft cable		
			09 8.0 dBi omni w/remote bkt. mount, str. design 11 ft cable		
			10 2.2 dBi omni w/remote mag. mount, tilt/swivel 10 ft cable		



Limitless™ Receiver

WDRR Wireless Din-Rail Receiver
Dimensions and Ordering Options

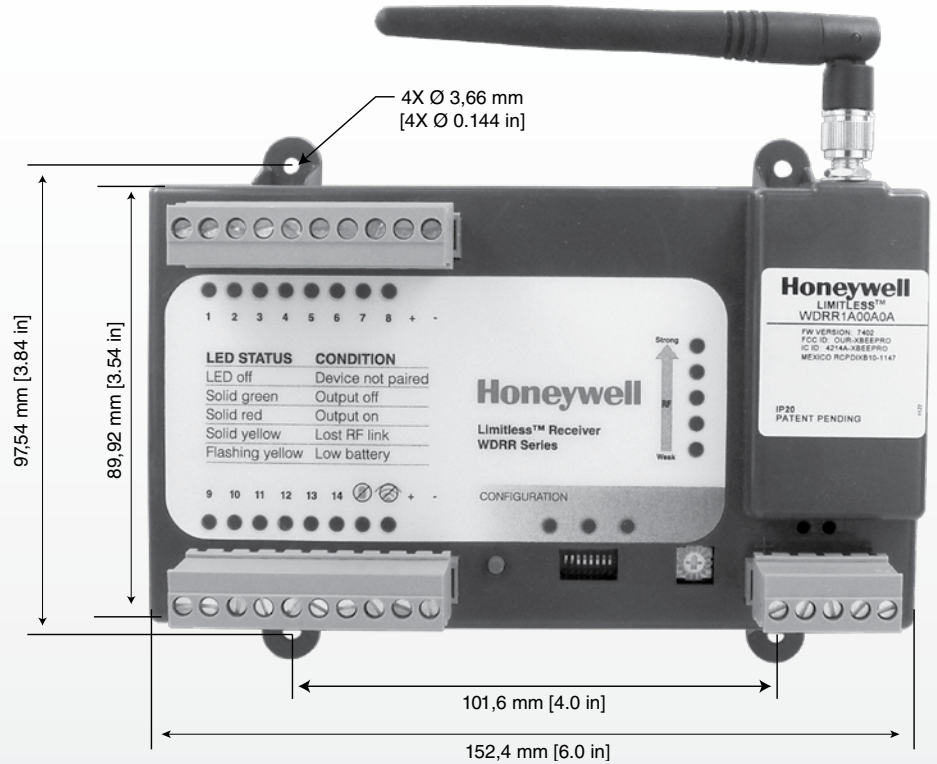

WDRR NOMENCLATURE

WDRR	1	A	00	A	0	A
Switch type	GEN code	RF Code	Antenna type code	Country use code	Output code	Channel code
WDRR Series Din-Rail Receiver	1 Version 1	A 2.4 GHz; IEEE 802.15.4	00 No antenna; RP-SMA connector jack	A US, Canada Mexico	0 NPN/PNP selectable	A 14 channels
			01 2.2 dBi omni w/switch mount; straight design	B All other approved countries ^{1,2,3}		
			02 2.2 dBi omni w/switch mount; tilt/swivel	¹ Use with antenna type codes 00 - 03, 05, 10, 11 only; usage allowed in Country Code A.		
			03 3.0 dBi omni w/remote adhesive mount 9.8 ft cable	² Some countries require specific communication certifications. Contact Honeywell for existing certification information.		
			04 5.5 dBi omni w/remote mag. mount, tilt/swivel 5 ft cable	³ If Limitless™ devices are used on machinery that may be shipped globally, use Country Code "B".		
			05 5.5 dBi omni w/remote mag. mount, tilt/swivel 10 ft cable			
			06 9.0 dBi omni w/remote mag. mount, tilt/swivel 5 ft cable			
			07 9.0 dBi omni w/remote mag. mount, tilt/swivel 10 ft cable			
			08 8.0 dBi omni w/remote bkt. mount, str. design 3 ft cable			
			09 8.0 dBi omni w/remote bkt. mount, str. design 11 ft cable			
			10 2.2 dBi omni w/remote mag. mount, tilt/swivel 10 ft cable			

Limitless™ Limit Switch Series

WLS Series

Operating Heads with Wobble Sticks



LSZ1JGM
13.0 inch spring wire wobble



LSZ1JGA
5.5 inch Delrin® rod wobble



LSZ1JGN
5.5 inch cable wobble



Limitless™ switch actuators may be custom designed by Honeywell S&C's engineering team to ensure optimum actuation for specific applications.

Limitless™ Series

Accessories



Antenna
Type Code
"01"

WAN01RSP
straight design,
2.2 dBi gain,
direct mount
connector



Antenna
Type Code
"02"

WAN02RSP
tilt & swivel design,
2.2 dBi gain,
direct mount
connector



Antenna Type
Code "03"

WAN03RSP
flat design,
3 dBi gain,
adhesive mount



WAN04RSP
tilt & swivel design,
5.5 dBi gain,
direct mount
connector



Antenna Type
Code "06"

**WAN05RSP &
WAMM100RSP-005**
T/S, 9 dBi gain,
magnetic mount



WAN06RNJ
straight design,
8 dBi gain,
bracket mount



Antenna
Type Code
"11"

WAN07RSP
straight design,
0 dBi gain, direct
mount connector



WAN09RSP
low-profile mobile antenna,
3.0 dBi gain, magnetic mount



WAN10RSP
straight mobile antenna,
5.0 dBi gain,
magnetic mount



WAN11RSP
low-profile dome antenna,
4.0 dBi gain, through-hole screw mount



WPB1
WPMM mounting
bracket



WPR1
WPMM panel mount
retainer



WCA200 Series
200 series coax cable assembly
available in a variety of lengths



WAMM100RSP-005/010
100 series coax antenna mount
available in 5 ft. and 10 ft. lengths

Limitless™ Series

WGLA Standard Listings

Limitless™ WGLA Global Limit Switches for use in US/Canada/Mexico

Side rotary

WGLA	1A01	A	A1A	Limitless™ WGLA, 2.2 dBi straight antenna, momentary, standard lever with nylon roller
WGLA	1A01	A	A1B	Limitless™ WGLA, 2.2 dBi straight antenna, momentary, standard lever with steel roller
WGLA	1A01	A	A4J	Limitless™ WGLA, 2.2 dBi straight antenna, momentary, 200 mm aluminum adjustable rod actuator
WGLA	1A02	A	A1A	Limitless™ WGLA, 2.2 dBi tilt & swivel antenna, momentary, standard lever with nylon roller
WGLA	1A02	A	A1B	Limitless™ WGLA, 2.2 dBi tilt & swivel antenna, momentary, standard lever with steel roller
WGLA	1A02	A	A4J	Limitless™ WGLA, 2.2 dBi tilt & swivel antenna, momentary, 200 mm aluminum adjustable rod actuator
WGLA	1A04	A	A1A	Limitless™ WGLA, 5.5 dBi remote magnetic mount/t&s antenna with 5ft of cable, momentary, standard lever with nylon roller
WGLA	1A04	A	A1B	Limitless™ WGLA, 5.5 dBi remote magnetic mount/t&s antenna with 5ft of cable, momentary, standard lever with steel roller
WGLA	1A04	A	A4J	Limitless™ WGLA, 5.5 dBi remote magnetic mount/t&s antenna with 5ft of cable, momentary, 200 mm aluminum adj. rod

Top actuators

WGLA	1A01	A	B	Limitless™ WGLA, 2.2 dBi straight antenna, top pin plunger
WGLA	1A01	A	C	Limitless™ WGLA, 2.2 dBi straight antenna, top roller plunger
WGLA	1A01	A	D	Limitless™ WGLA, 2.2 dBi straight antenna, top roller lever
WGLA	1A02	A	B	Limitless™ WGLA, 2.2 dBi tilt & swivel antenna, top pin plunger
WGLA	1A02	A	C	Limitless™ WGLA, 2.2 dBi tilt & swivel antenna, top roller plunger
WGLA	1A02	A	D	Limitless™ WGLA, 2.2 dBi tilt & swivel antenna, top roller lever
WGLA	1A04	A	B	Limitless™ WGLA, 5.5 dBi remote magnetic mount/tilt & swivel antenna with 5 ft of cable, top pin plunger
WGLA	1A04	A	C	Limitless™ WGLA, 5.5 dBi remote magnetic mount/tilt & swivel antenna with 5 ft of cable, top roller plunger
WGLA	1A04	A	D	Limitless™ WGLA, 5.5 dBi remote magnetic mount/tilt & swivel antenna with 5 ft of cable, top roller lever

Limitless™ WGLA Global Limit Switches for use in all other approved countries

Side rotary

WGLA	1A01	B	A1A	Limitless™ WGLA, 2.2 dBi straight antenna, momentary, standard lever with nylon roller
WGLA	1A01	B	A1B	Limitless™ WGLA, 2.2 dBi straight antenna, momentary, standard lever with steel roller
WGLA	1A01	B	A4J	Limitless™ WGLA, 2.2 dBi straight antenna, momentary, 200 mm aluminum adjustable rod actuator
WGLA	1A02	B	A1A	Limitless™ WGLA, 2.2 dBi tilt & swivel antenna, momentary, standard lever with nylon roller
WGLA	1A02	B	A1B	Limitless™ WGLA, 2.2 dBi tilt & swivel antenna, momentary, standard lever with steel roller
WGLA	1A02	B	A4J	Limitless™ WGLA, 2.2 dBi tilt & swivel antenna, momentary, 200 mm aluminum adjustable rod actuator
WGLA	1A04	B	A1A	Limitless™ WGLA, 5.5 dBi remote magnetic mount/t&s antenna with 5ft of cable, momentary, standard lever with nylon roller
WGLA	1A04	B	A1B	Limitless™ WGLA, 5.5 dBi remote magnetic mount/t&s antenna with 5ft of cable, momentary, standard lever with steel roller
WGLA	1A04	B	A4J	Limitless™ WGLA, 5.5 dBi remote magnetic mount/t&s antenna with 5ft of cable, momentary, 200 mm aluminum adj.

Top actuators

WGLA	1A01	B	B	Limitless™ WGLA, 2.2 dBi straight antenna, top pin plunger
WGLA	1A01	B	C	Limitless™ WGLA, 2.2 dBi straight antenna, top roller plunger
WGLA	1A01	B	D	Limitless™ WGLA, 2.2 dBi straight antenna, top roller lever
WGLA	1A02	B	B	Limitless™ WGLA, 2.2 dBi tilt & swivel antenna, top pin plunger
WGLA	1A02	B	C	Limitless™ WGLA, 2.2 dBi tilt & swivel antenna, top roller plunger
WGLA	1A02	B	D	Limitless™ WGLA, 2.2 dBi tilt & swivel antenna, top roller lever
WGLA	1A04	B	B	Limitless™ WGLA, 5.5 dBi remote magnetic mount/tilt & swivel antenna with 5 ft of cable, top pin plunger
WGLA	1A04	B	C	Limitless™ WGLA, 5.5 dBi remote magnetic mount/tilt & swivel antenna with 5 ft of cable, top roller plunger
WGLA	1A04	B	D	Limitless™ WGLA, 5.5 dBi remote magnetic mount/tilt & swivel antenna with 5 ft of cable, top roller lever

Limitless™ Series

WLS Standard Listings

Limitless™ WLS Heavy-Duty Limit Switches for use in US/Canada/Mexico

Side rotary

WLS	1A00	A	A	Limitless™ heavy-duty limit switch, no antenna, momentary, no lever
WLS	1A01	A	A1A	Limitless™ heavy-duty limit switch, 2.2 dBi straight antenna, momentary, fixed 1.5 in lever with nylon roller
WLS	1A01	A	A1B	Limitless™ heavy-duty limit switch, 2.2 dBi straight antenna, momentary, fixed 1.5 in lever with steel roller
WLS	1A01	A	A2A	Limitless™ heavy-duty limit switch, 2.2 dBi straight antenna, momentary, adjustable 3.5 in lever with nylon roller
WLS	1A01	A	A2B	Limitless™ heavy-duty limit switch, 2.2 dBi straight antenna, momentary, adjustable 3.5 in lever with steel roller
WLS	1A02	A	A1A	Limitless™ heavy-duty limit switch, 2.2 dBi tilt/swivel antenna, momentary, fixed 1.5 in lever with nylon roller
WLS	1A02	A	A1B	Limitless™ heavy-duty limit switch, 2.2 dBi tilt/swivel antenna, momentary, fixed 1.5 in lever with steel roller
WLS	1A02	A	A2A	Limitless™ heavy-duty limit switch, 2.2 dBi tilt/swivel antenna, momentary, adjustable 3.5 in lever with nylon roller
WLS	1A02	A	A2B	Limitless™ heavy-duty limit switch, 2.2 dBi tilt/swivel antenna, momentary, adjustable 3.5 in lever with steel roller

Side rotary, maintained head

WLS	1A00	A	N	Limitless™ heavy-duty limit switch, no antenna, maintained, no lever
WLS	1A01	A	N	Limitless™ heavy-duty limit switch, 2.2 dBi straight antenna, maintained, no lever
WLS	1A02	A	N	Limitless™ heavy-duty limit switch, 2.2 dBi tilt/swivel antenna, maintained, no lever

Top actuators

WLS	1A00	A	C	Limitless™ heavy-duty limit switch, no antenna, top plunger
WLS	1A00	A	D	Limitless™ heavy-duty limit switch, no antenna, top roller plunger
WLS	1A01	A	C	Limitless™ heavy-duty limit switch, 2.2 dBi straight antenna, top plunger
WLS	1A01	A	D	Limitless™ heavy-duty limit switch, 2.2 dBi straight antenna, top roller plunger
WLS	1A02	A	C	Limitless™ heavy-duty limit switch, 2.2 dBi tilt/swivel antenna, top plunger
WLS	1A02	A	D	Limitless™ heavy-duty limit switch, 2.2 dBi tilt/swivel antenna, top roller plunger

Limitless™ WLS Heavy-Duty Limit Switches for use in all other approved countries

Side rotary

WLS	1A00	B	A	Limitless™ heavy-duty limit switch, no antenna, momentary, no lever
WLS	1A01	B	A1A	Limitless™ heavy-duty limit switch, 2.2 dBi straight antenna, momentary, fixed 1.5 in lever with nylon roller
WLS	1A01	B	A1B	Limitless™ heavy-duty limit switch, 2.2 dBi straight antenna, momentary, fixed 1.5 in lever with steel roller
WLS	1A01	B	A2A	Limitless™ heavy-duty limit switch, 2.2 dBi straight antenna, momentary, adjustable 3.5 in lever with nylon roller
WLS	1A01	B	A2B	Limitless™ heavy-duty limit switch, 2.2 dBi straight antenna, momentary, adjustable 3.5 in lever with steel roller
WLS	1A02	B	A1A	Limitless™ heavy-duty limit switch, 2.2 dBi tilt/swivel antenna, momentary, fixed 1.5 in lever with nylon roller
WLS	1A02	B	A1B	Limitless™ heavy-duty limit switch, 2.2 dBi tilt/swivel antenna, momentary, fixed 1.5 in lever with steel roller
WLS	1A02	B	A2A	Limitless™ heavy-duty limit switch, 2.2 dBi tilt/swivel antenna, momentary, adjustable 3.5 in lever with nylon roller
WLS	1A02	B	A2B	Limitless™ heavy-duty limit switch, 2.2 dBi tilt/swivel antenna, momentary, adjustable 3.5 in lever with steel roller

Side rotary, maintained head

WLS	1A00	B	N	Limitless™ heavy-duty limit switch, no antenna, maintained, no lever
WLS	1A01	B	N	Limitless™ heavy-duty limit switch, 2.2 dBi straight antenna, maintained, no lever
WLS	1A02	B	N	Limitless™ heavy-duty limit switch, 2.2 dBi tilt/swivel antenna, maintained, no lever

Top actuators

WLS	1A00	B	C	Limitless™ heavy-duty limit switch, no antenna, top plunger
WLS	1A00	B	D	Limitless™ heavy-duty limit switch, no antenna, top roller plunger
WLS	1A01	B	C	Limitless™ heavy-duty limit switch, 2.2 dBi straight antenna, top plunger
WLS	1A01	B	D	Limitless™ heavy-duty limit switch, 2.2 dBi straight antenna, top roller plunger
WLS	1A02	B	C	Limitless™ heavy-duty limit switch, 2.2 dBi tilt/swivel antenna, top plunger
WLS	1A02	B	D	Limitless™ heavy-duty limit switch, 2.2 dBi tilt/swivel antenna, top roller plunger

Limitless™ Series

Receiver Listings

Limitless™ WPMM Standard Listing

Part Number Description

Output: NPN normally open current sinking

WPMM	1A00	A		Limitless™ WPMM monitor with NPN output, no antenna, US/Canada/Mexico
WPMM	1A02	A		Limitless™ WPMM monitor with NPN output, 2.2 dBi omni antenna (tilt & swivel design), US/Canada/Mexico
WPMM	1A03	A		Limitless™ WPMM monitor w/ NPN output, 3.0 dBi omni antenna with remote adhesive mount. w/ 9.8 ft cable, US/Canada/Mexico
WPMM	1A04	A		Limitless™ WPMM monitor with NPN output, 5.5 dBi omni antenna (tilt & swivel design) with remote magnetic mounting with 5 ft cable, US/Canada/Mexico
WPMM	1A05	A		Limitless™ WPMM monitor with NPN output, 5.5 dBi omni antenna (tilt & swivel design) with remote magnetic mounting with 10 ft cable, US/Canada/Mexico
WPMM	1A00	B		Limitless™ WPMM monitor with NPN output, no antenna, for use in all other approved countries
WPMM	1A02	B		Limitless™ WPMM monitor with NPN output, 2.2 dBi omni antenna (tilt & swivel design), for use in all other approved countries
WPMM	1A03	B		Limitless™ WPMM monitor w/ NPN output, 3.0 dBi omni antenna w/ remote adhesive mounting with 9.8 ft cable, for use in all other approved countries
WPMM	1A04	B		Limitless™ WPMM monitor with NPN output, 5.5 dBi omni antenna (tilt & swivel design) with remote magnetic mounting with 5 ft cable, for use in all other approved countries
WPMM	1A05	B		Limitless™ WPMM monitor with NPN output, 5.5 dBi omni antenna (tilt & swivel design) with remote magnetic mounting with 10 ft cable, for use in all other approved countries

Output: PNP normally open current sourcing

WPMM	1A00	A	P01	Limitless™ WPMM monitor with PNP output, no antenna, US/Canada/Mexico
WPMM	1A00	B	P01	Limitless™ WPMM monitor with PNP output, no antenna, for use in all other approved countries

Output: Solid state relay

WPMM	1A02	A	S01	Limitless™ WPMM monitor with solid state relay, 2.2 dBi omni antenna (tilt & swivel design), US/Canada/Mexico
------	------	---	-----	---

Limitless™ WDRR Standard Listings

Part Number Description

WDRR	1A00	A	0A	Limitless™ DIN-Rail receiver, no antenna, US/Canada/Mexico
WDRR	1A03	A	0A	Limitless™ DIN-Rail receiver, 3.0 dBi omni antenna with remote adhesive mounting with 9.8 ft cable, US/Canada/Mexico
WDRR	1A05	A	0A	Limitless™ DIN-Rail receiver, 5.5 dBi omni antenna (tilt/swivel design) with remote magnetic mounting/10 ft cable, US/Canada/Mexico
WDRR	1A00	B	0A	Limitless™ DIN-Rail receiver, no antenna, for use in all other approved countries
WDRR	1A03	B	0A	Limitless™ DIN-Rail receiver, 3.0 dBi omni antenna with remote adhesive mounting with 9.8 ft cable, for use in all other approved countries
WDRR	1A05	B	0A	Limitless™ DIN-Rail receiver, 5.5 dBi omni antenna (tilt/swivel design) with remote magnetic mounting/10 ft cable, for use in all other approved countries

Limitless™ Series

Standard Antenna Listings

Limitless™ WCA 200 Series Cable Standard Listings

Part Number	Description
WCA200RNPRSP-002	Limitless™ Series wireless cable assembly wth 200 Series cable, 2 ft length, reverse polarity N plug to reverse polarity SMA plug, use only with WAN06RNJ antenna
WCA200RNPRSP-010	Limitless™ Series wireless cable assembly wth 200 Series cable, 10 ft length, reverse polarity N plug to reverse polarity SMA plug, use only with WAN06RNJ antenna
WCA200RNJRSP-002	Limitless™ Series wireless cable assembly wth 200 Series cable, 2 ft length, reverse polarity SMA jack to reverse polarity SMA plug
WCA200RNJRSP-005	Limitless™ Series wireless cable assembly wth 200 Series cable, 5 ft length, reverse polarity SMA jack to reverse polarity SMA plug
WCA200RNJRSP-010	Limitless™ Series wireless cable assembly wth 200 Series cable, 10 ft length, reverse polarity SMA jack to reverse polarity SMA plug
WCA200RNJRSP-015	Limitless™ Series wireless cable assembly wth 200 Series cable, 15 ft length, reverse polarity SMA jack to reverse polarity SMA plug
WCA200RNJRSP-020	Limitless™ Series wireless cable assembly wth 200 Series cable, 20 ft length, reverse polarity SMA jack to reverse polarity SMA plug

Limitless™ Wireless Antenna Standard Listings

Part Number	Description
WAN01RSP	Limitless™ Series straight wireless antenna with 2.2 dBi gain, reverse polarity SMA plug, connector mount (RP-SMA)
WAN02RSP	Limitless™ Series tilt/swivel wireless antenna with 2.2 dBi gain, reverse polarity SMA plug, connector mount (RP-SMA)
WAN03RSP	Limitless™ Series flat wireless antenna with 3 dBi gain, reverse polarity SMA plug, adhesive mount with 3,05 m [10 ft] cable
WAN04RSP*	Limitless™ Series tilt/swivel wireless antenna with 5.5 dBi gain, reverse polarity SMA plug, connector mount (RP-SMA)
WAN05RSP*	Limitless™ Series tilt/swivel wireless antenna with 9 dBi gain, reverse polarity SMA plug, connector mount (RP-SMA)
WAN06RNJ*	Limitless™ Series straight wireless antenna with 8 dBi gain, reverse polarity N jack, bracket mount with 0,31 m [1 ft] cable
WAN07RSP	Limitless™ Series straight wireless antenna with 0 dBi gain, reverse polarity SMA plug, connector mount 0 dBi straight w/RP-SMA plug
WAN08RSP	Limitless™ Series right angle wireless antenna with 0 dBi gain, reverse polarity SMA plug, connector mount 0 dBi straight w/RP-SMA plug
WAN09RSP	Limitless™ Series low profile straight antenna with 3.0 dBi gain, reverse polarity SMA plug, mobile magnetic mount with 4,57 m [15 ft] cable
WAN10RSP	Limitless™ Series straight antenna with 5.0 dBi gain, reverse polarity SMA plug, mobile magnetic mount with 4,57 m [15 ft] cable
WAN11RSP*	Limitless™ Series low profile dome antenna with 4.0 dBi gain, reverse polarity SMA plug, mobile thru-hole screw mount with 3 m [9.8 ft] cable

* not allowed for use with Country Code "B" Limitless™ products.



There's an advantage for taking the bold step. For seeing the possibilities. And seizing the opportunity.

At Honeywell Sensing and Control, we work hard to lead the way. To develop technologies that are ahead of the curve. To deliver solutions that anticipate your needs. And sometimes that innovative mind set allows you to be the market leader. That's why Limitless™ switches are the leading wireless switch brand on the market.

And you can rest assured, Limitless™ switches are the right product at the right time to help you maximize efficiency and minimize cost. Because it's a Honeywell product, backed by world-class service and support.

Part Innovation. Part Engineering. Total Solutions.

Limitless™ Solutions

- Wireless global limit switches
- Wireless heavy-duty switches
- Wireless monitors and receivers
- Wireless operator interface

Potential Applications

- Construction/Ag machines
- Conveyors
- Crane/boom/jib/skew position
- Door position
- Grain diverters or flaps
- Hose attachment verification
- Lifts
- Material handling machinery
- Moveable machinery
- Presses
- Remote or temporary equipment
- Valve position

Find Out More

To learn more about Limitless™ wireless limit switches, contact a Honeywell representative today at

1-800-537-6945 or visit

<http://sensing.honeywell.com/limitless>

Sensing and Control

Honeywell

1985 Douglas Drive North

Golden Valley, MN 55422

sensing.honeywell.com

WARRANTY/REMEDY

Honeywell warrants goods of its manufacture as being free of defective materials and faulty workmanship. Honeywell's standard product warranty applies unless agreed to otherwise by Honeywell in writing; please refer to your order acknowledgement or consult your local sales office for specific warranty details. If warranted goods are returned to Honeywell during the period of coverage, Honeywell will repair or replace, at its option, without charge those items it finds defective.

The foregoing is buyer's sole remedy and is in lieu of all other warranties, expressed or implied, including those of merchantability and fitness for a particular purpose. In no event shall Honeywell be liable for consequential, special, or indirect damages.

While we provide application assistance personally, through our literature and the Honeywell web site, it is up to the customer to determine the suitability of the product in the application.

Specifications may change without notice. The information we supply is believed to be accurate and reliable as of this printing. However, we assume no responsibility for its use.

SALES AND SERVICE

Honeywell serves its customers through a worldwide network of sales offices, representatives and distributors. For application assistance, current specifications, pricing or name of the nearest Authorized Distributor, contact your local sales office or:

E-mail: info.sc@honeywell.com

Internet: <http://sensing.honeywell.com/limitless>

Phone and Fax:

Asia Pacific	+65 6355-2828; +65 6445-3033 Fax
Europe	+44 (0) 1698 481481; +44 (0) 1698 481676 Fax
Latin America	+1-305-805-8188; +1-305-883-8257 Fax
USA/Canada	+1-800-537-6945; +1-815-235-6847
	+1-815-235-6545 Fax

Honeywell