

electromagnetic
integrated
solutions
full line catalog



api 
technologies corp.
Spectrum Control



Spectrum Control

Electromagnetic Integrated Solutions

API Technologies has been the world's leading provider of custom application-specific EMI filter solutions since 1968. Through our Spectrum Control line we offer a wide range of standard products and we'll develop a new or modified product or integrated assembly to help you address the mechanical, electrical and/or power requirements of your next design. Our family of electromagnetic integrated solutions includes not only the industry's most complete line of coaxial EMI components, power surface mount filters, filtered connectors, filtered arrays, power filters and EMC testing services, but also an expanded offering of ceramic capacitors, power film capacitors, filtered and unfiltered interconnects, and magnetics.

Table of Contents:

| | |
|---|------------------|
| EMI Filter Solutions | 2-3 |
| Integration, Global & Technical Resources | 4-5 |
| Product Applications | 6-7 |
| EMC Test Capabilities | 8-9 |
| EMI Selection Guide | 10-13 |
| Ceramic Capacitors | CC1-CC20 |
| Coaxial Filters & Interconnects | CF2-CF16 |
| Surface Mount EMI Filters | SM1-SM21 |
| Low Pass EMI Filters | LP1-LP42 |
| EMI Filtered Arrays | FA1-FA25 |
| EMI Filtered Connectors | FC1-FC68 |
| QuietShield Caskets & Shielding . . | FC69-FC77 |
| Specialty Connectors & Custom Cable Assemblies | SC1-SC9 |
| Power Filters & Film Capacitors . . . | PF1-PF102 |
| Magnetics | MG1-MG4 |

Innovative Solutions from Components to Complex Assemblies

Understanding how and where potential EMI problems exist in an electronic system can be a daunting challenge. Uncovering the best way to address both conducted and radiated EMI by understanding all the mechanical, electrical and environmental concerns of your system can reduce costs and keep a project on budget and schedule. Our extensive library of standard components, which we frequently develop into custom assemblies, offers you a more complete, high performance solution... saving you time and money.

Industry's Broadest Line of Standard Products

We offer the flexibility to filter EMI at the power source, at the I/O connection, in a barrier wall or on the PCB. Our industry-leading line, including inductors, glass and resin sealed filters, SMT filters, filter plates, filtered connectors, power entry and power line filters, military/aerospace multisection filters and magnetics, gives you a wide range of size, performance and packaging options, most available RoHS compliant. In addition, we've got over 800 standard MIL QPL products and DSCC part numbers.

Custom Application-Specific Solutions

This phrase serves as an excellent summary of what we produce for our customers, as well as defines what distinguishes our company from others in the electronics market. Rarely does a 100% off-the-shelf component completely satisfy the mechanical, electrical, and/or power requirements and constraints of a sophisticated OEM design. Whether modifying an existing component, working from a "clean sheet" approach, or integrating various technologies into a subassembly or system, the result will be a tailored API Technologies' Spectrum Control design for your exact application parameters, one that pushes the envelope of product performance.

As the world leader in EMI products and a market leader in microwave, power and sensor products, our customers rely on us to create and provide optimized solutions that improve their competitive advantage.

PDF Linking

For your convenience, this PDF has been linked throughout. On each page, clicking on the API logo will bring you back to the main table of contents (p 2). Additionally, clicking each product title bar brings you to that section's table of contents, where all listed products are also linked. Interested in going to API's website? Look for the hyperlink eis.apitech.com at the bottom of each page.

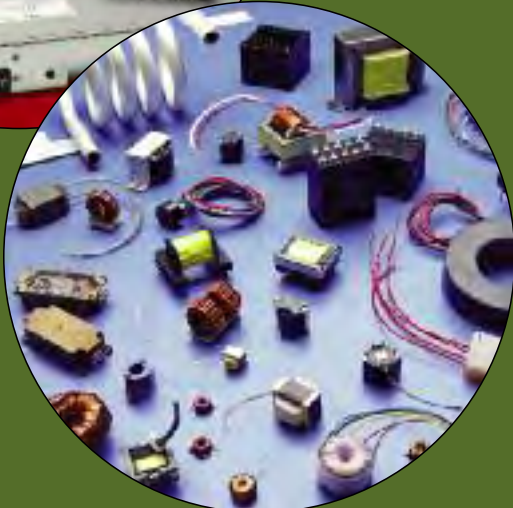

Product Families

Ceramic Capacitors

- Capacitor arrays
- SMPS modular capacitors
- Planar capacitors
- Discoidal and tubular capacitors

Coaxial Filters & Interconnects

- Resin and hermetically sealed filters
- Motor-line feed-through filters (MLFT)
- High current/high voltage filters
- Miniature hermetically sealed and surface mount filters
- Filter plates and terminal blocks
- D-sub and combo filtered connectors
- Ribbon and datacomm connectors
- Rugged USB connectors

Specialty Connectors & Custom Cable Assemblies

- Circular connectors
- Mini-MIL and Rapid Mate connectors
- Audio and glass sealed connectors
- Value-added terminations and harnesses
- Custom cable assemblies

Power Filters & Film Modules

- Commercial power filters
- Military/aerospace power filters
- Power entry modules
- Film feed-through filters
- Film modules

Magnetics

- Current transformers
- Power transformers
- Inductors, chokes and filters
- Switch mode power supply inductors
- Modem and module transformers
- Air coils

Vertical Integration

Our business teams coordinate and share extensive in-house resources to support many of the problem-solving designs and value-added programs we create. Internal capabilities range from formulating and producing the ceramics used in many of our products to complete metal fabrication, which facilitates the mechanical/packaging requirements of our customers' designs. Specific technologies are sourced from multiple locations using expertise found throughout our organization, often crossing business segments to find the ideal production method, including use of our MIL-STD-790 and TS16949 certified factories.

Low Cost Manufacturing Centers

ISO9001:2000 certified API Technologies adheres to world class manufacturing techniques ensuring each customer receives the Six Sigma reliability they demand. In response to the realities of the marketplace, we have established low cost manufacturing facilities in China and Mexico. These new plants complement our North American production capacity and flexible manufacturing systems, allowing us to ramp-up production to meet fast-track delivery requirements.

Global Reach

Today, more than ever, it is imperative suppliers be prepared to support their customers around the world. API Technologies has created a network of sales and design centers, manufacturing plants and distribution facilities to support the world's major markets. From field sales specialists to engineering and manufacturing to logistics, we have moved our key program development personnel closer to our customers regardless of their location. We are committed to being a player in the global economy and ideal partner for our worldwide OEM customers.



An Engineering & Technology Leader

The heritage of our company, dating to its founding in 1968, is as an engineering driven, solutions provider. Through the years of expansion and acquisition, this basic premise remains a constant and driving force. Our teams of experienced application engineers use sophisticated simulation software to replicate real-world environments. Once product designs are complete, we conduct exhaustive in-house testing and verification to ensure function and compliance. API Technologies maintains a leadership position in many industries by applying the latest technology to design performance-enhancing products and systems.



R & D Commitment... Creating the Next Generation

The surest way to guarantee organic new product development is through investment in research personnel and equipment. API Technologies consistently commits the resources necessary to fund the innovation and creativity leading to technological advancements. We constantly are looking for ways to improve existing designs, as well as find entirely new approaches yielding unforeseen benefits. All of our business units have made significant new product introductions in recent years.

Optimized Designs

Defense

- Specialty Connectors
- QPL'd Coaxial Filters
- Military Custom Power Filters
- Ceramic Capacitors
- Magnetics

Communications

- Coaxial Interconnects
- Commercial Custom Power Filters
- Surface Mount Filters
- Magnetics

Avionics

- Specialty Connectors
- Coaxial Filters and Interconnects
- Film Modules
- Custom Power Filters
- Magnetics

*for a wide range of new
applications and markets*

Alternate Energy

- Film Modules
- Specialty Ceramics
- Magnetics

Medical

- Coaxial Filters and Interconnects
- Ceramic Capacitors
- Power Filters
- Magnetics

Industrial

- Ceramic Capacitors
- Coaxial Filters and Interconnects
- Film Modules
- Specialty Connectors and Custom Cable Assemblies
- Magnetics

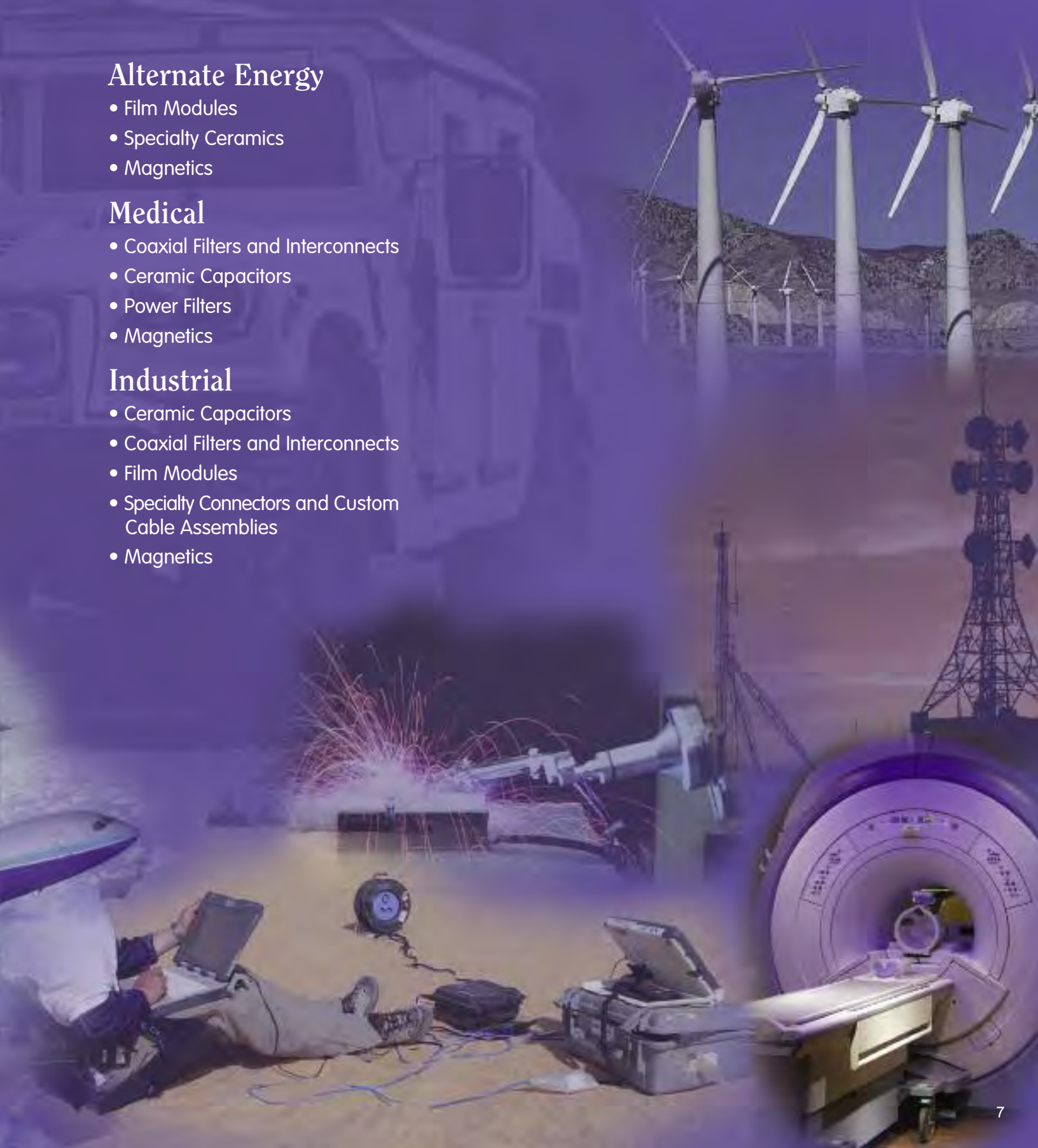

EMI Testing Services

API Technologies has the EMC expertise and in-house filter solutions you need to meet worldwide EMC standards.

Our EMC testing services offer you a flexible resource to assist in product development by identifying and correcting EMI susceptibility and/or emission problems. API has a fully equipped EMC testing laboratory and an experienced engineering staff ready to solve demanding EMC challenges. For a modest daily fee, we can test your equipment, determine state of compliance, and work with you in developing a viable solution. It is not uncommon for clients to leave our lab with a prototype in hand.



EMC Lab Highlights

- NARTE certified staff
- Semi-anechoic chamber
- Computer controlled instrumentation
- Graphical data presentation in multiple formats
- Fiber optic video monitoring system

Testing Capabilities

MILITARY

MIL-STD-461 A/B/C/D/E

MIL-STD-1399

AUTOMOTIVE

CISPR 25 Test Methods

COMMERCIAL

FCC-Part 15

RTCA/DO-160 A/B/C/D

GR-1089-CORE

INTERNATIONAL

EN55011/CISPR 11

EN55014/CISPR 14

EN55022/CISPR 22

EN61000-4-2 Electrostatic Discharge

EN61000-4-3 Radiated RF Immunity

EN61000-4-4 Electrical Fast Transient

EN61000-4-5 Surge

EN61000-4-6 Conducted RF Immunity



EMI/RFI Filter and Capacitor Performance Testing

Reliability Levels

Class B

Class B is outlined in MIL-PRF-28861 and is prescribed for most military/aerospace requirements.

It is more stringent than MIL-PRF-15733, requiring 100% screening that includes thermal shock, voltage conditioning and x-ray.

Periodic Group B testing is performed on units selected at random from production lots.



Class B MIL-PRF-28861 Test Sequence Summary "R" level testing

| Inspection | Class B |
|---|---------|
| Group I | |
| AC voltage drop (when applicable) | X |
| Voltage and temperature limits of capacitance | X |
| Insertion loss (at temperature) | X |
| Barometric pressure (reduced) | X |
| Temperature rise | X |
| Current overload | X |
| Terminal strength | X |
| Thermal shock and immersion | X |
| Group II | |
| Subgroup 1 | |
| Life | X |
| Subgroup 2 | |
| Resistance to soldering heat | X |
| Salt spray (corrosion) | X |
| Radiographic inspection | X |
| Subgroup 3 | |
| Resistance to solvents | X |
| Group III | |
| Shock (specified pulse) | X |
| Vibration (high frequency) | X |
| Moisture resistance | X |
| Seal (when applicable) | X |
| Radiographic inspection | X |

"R" level testing

"R" level screening is performed by API Technologies' Hi-Rel Laboratory as detailed below. Customers requiring special tests may order to their own specifications or simply order to level R and then note additions or deviations.

"R" level test sequence

(100% testing unless otherwise specified)

- Thermal Shock: 5 cycles from -55°C to +125°C in accordance with MIL-STD-202, Method 107D, Condition A.
- Burn-in: 100 hours at 1.4x rated DC voltage, 125°C.
- Seal Test: MIL-STD-202, Method 112, Test Condition A. Hermetic sealed parts only.
- Capacitance and Dissipation Factor: MIL-STD-202, Method 305, frequency 1kHz.
- Dielectric Withstanding Voltage: 2.5 times the rated DC voltage for 5 ±1 second at 25°C, with 50 mA maximum charging current.
- Insulation Resistance: MIL-STD-202, Method 302, 125°C at rated DC voltage and room temperature (25°C). The 125°C requirement shall be 10% of the specified catalog IR at 25°C.
- DC Resistance: MIL-STD-202, Method 303.
- Insertion Loss Test: Sample per MIL-PRF-15733. At full rated load in accordance with MIL-STD-220. The minimum insertion loss shall be defined in the filter catalog.
- Visual and Mechanical: In accordance with MIL-PRF-15733.
- Marking: All filters which have successfully completed the test sequence shall be marked with an "R" in the second part of the number. For example, a standard SCI-2130-004 becomes SCI-R2130-004 and 9051-100-0000 becomes 9051-R100-0000, and 51-719-011 becomes 51-R719-011 after completion of the Hi-Rel Level "R" Test Sequence.

Electromagnetic Integrated Solutions Selection Guide

CERAMIC CAPACITORS

Specialty Ceramic Components



Medical implantable devices, EMI/RFI suppression filters, commercial and military applications, power supplies, converters

Advanced Ceramics



Chemical and fluid handling systems, microwave hybrid applications, HF/RF power amplifiers, computer, medical and network products, multi line designs, circular and D-sub connectors

Applications

Features / Benefits

- **Discoidals**
Low inductance, non-polar
Filtering and decoupling of high frequency applications
Reliable, low profile, multi-layered designs
- **Tubular Capacitors**
Small, lightweight, reliable, high dielectric strength
Uniform insertion loss over a broad frequency range
- **Switch Mode Power Supplies**
Ideal for DC-DC power supply applications
Capacitor assemblies with low ESR/ESL
Leaded configuration safeguards the device against thermal and mechanical stresses
- **Fed/MIL approvals**
MIL-PRF-49470 approvals

- **Structural Ceramics**
High wear and corrosion resistance
Temperature stability and strength
Superior thermal shock resistance
Custom solutions available
- **Capacitor Arrays**
Variable mounting style selection
Decreased assembly time – one placement
Reduced component stress
Parallel and series configurations of chip capacitors
- **Planars**
Custom geometry configurations available
Design flexibility with multiple capacitance values
Established circular, D-sub and mini connector designs available

- **Discoidals**
.080 to 0.600 in. diameter
50 to 500 Volt
NPO, X7R and Z5U ceramic available
- **Tubular Capacitors**
Feed-through and Pi circuit
0.081 to 0.122 in. diameter
50 to 200 Volt
- **Switch Mode Power Supplies**
BP, BX, BR or BQ ceramic available
Lead options: in, out or straight
50 to 500 Volt

- **Structural Ceramics**
Materials: Sialite, Cordierite and Alumina
Finishing methods: glazing, tumbling, plating
- **Planar & Capacitor Arrays**
Capacitance values up to 40 µF depending on array
Voltage ratings up to 1500 VDC
Temperature rating -55°C to 125°C



eis.apitech.com/ceramic

eis.apitech.com/ceramic

COAXIAL FILTERS & INTERCONNECTORS

Three Terminal Chips, Power/Square & Mini Surface Mount Filters



Cellular telephones and base stations, telecommunication equipment, computer and peripheral equipment, digital AV equipment such as TV, VCR and DVD, power amplifiers, power supplies, and temperature and motor controls

Miniature & Solder-in Filters



Ideal for microwave applications such as attenuators and oscillators. Perform well in high impedance circuits where large capacitance values are not practical

Hermetic/Resin Sealed Filters & MLFT Filters



Power supplies, signal lines, rocket igniters, aerospace, DC motors, telecomm & military/secure communications, medical equipment, mining/oil drilling, transceivers, microwave filters, industrial control systems, multi-circuit filter assemblies

- **Three Terminal Chips**
Non-polar, surface mountable
Superior filtering characteristics
Available in 0603, 0805, 1205, and 1806 sizes
- **Power, Square & Mini Surface Mount Filters**
PSM: 2 – 20 Amps (FT)
2 – 10 Amps (PI)
SSM & MSM: 10 Amps
High temperature construction
Small, square mechanical geometry enhances soldering to a PCB
Tape and reel and bulk packaging
Simple structure and high withstanding voltage

- **Small size options**
Ideal for use when real estate is limited
Solder-in, Knurled press-in & 2-56 threaded Spanner
- **Design flexibility**
Wide range of solder-in bushings with a variety of circuits: C, L, and Pi
Custom lead options available
- **Construction**
High temperature construction
- **Plating**
Suitable for gold bonding when specified
- **Coaxial**
Feed-through filtering
- **FED/MIL approvals**
Qualified to MIL-C-11015 and MIL-PRF-15733

- **Hermetic/Resin Sealed**
■ **Cost-effective solutions**
Low cost filters provide protection in hostile environments
- **Design flexibility**
Wide range of bushing sizes, lead configuration options and circuit types including C, L, Pi, transient suppression Pi, T, & TT
- **Reliability**
Built in accordance with MIL-PRF-15733 or MIL-PRF-28861
- **FED/MIL approvals**
Qualified to MIL-PRF-15733, MIL-PRF-28861 and DSCC 84084
- **Safety**
Some select filters U.L. 1459 recognized and CSAC22.2 certified
- **MLFT - Motor Line Feed-Through Filters**
■ **One component solution**
Eliminates the need for multiple capacitors, inductive coils, leads and PCB assemblies
- **Easy installation**
Provides a connector interface for a space saving EMI solution

- **Three Terminal**
■ **Voltage** Up to 100 VDC
■ **Current** Up to 2 Amps
■ **Capacitance** Up to 220,000 pF
- **PSM/SSM/MSM**
■ **Rated voltage**
50 – 200 VDC
■ **Capacitance** 47 pF to .01 µF
■ **Temp range**
-55°C to +125°C

- **Insertion loss range**
Effective filtering to 18 GHz in a shielded application
- **Capacitance**
Up to 30,000 pF
- **Operating voltage**
Up to 750 VDC
- **Temperature range**
-55°C to +125°C

- **Insertion loss range**
Effective filtering from 10 KHz to 18 GHz with proper installation
- **Capacitance and temperature characteristics**
To 5.2 µF NPO, X7R, Y5V, Z5U
- **Temperature range**
-55°C to +125°C
- **Voltage ratings (max.)**
To 2500 VDC
240 VAC @ 400 Hz
- **Current ratings (max.)**
To 100 Amps

Performance Characteristics



eis.apitech.com/smt



eis.apitech.com/lowpass

eis.apitech.com/lowpass

Electromagnetic Integrated Solutions Selection Guide

COAXIAL FILTERS & INTERCONNECTORS

Filter Plates & Shrouded Latch Plates & Assemblies



Telecommunications equipment, military, industrial, scientific, remote sensory and medical equipment

- **Total reduced costs**
Economical method of meeting EMC requirements
- **Excellent filtering**
Outperform surface mount filters at frequencies above 130 MHz; provide an EMI filtered signal line between electronic system modules
- **Reliability**
Every filter plate is tested 100% for key parameters
- **Standard centers**
0.100" and 2 mm centers allow for easy termination
- **Easy Mate™ filter plate**
Design provides for quick installation into predefined cutout
- **Microcircuit packages**
Custom designs available with a variety of materials, filtering and connectors
- **Rugged construction**
Shroud protects filter element from potential damage

- **Insertion loss range**
Effective insertion loss from 1 MHz to 18 GHz with proper installation
- **Capacitance**
Pi: 68 pF to 5000 pF
Feed-through: 10 pF to 4000 pF
- **Temperature characteristics**
NPO, X7R, Y5V, Z5U
- **Temperature range**
-55°C to +125°C
- **Voltage ratings (max.)**
To 250 VDC
- **Current ratings (max.)**
To 5 Amps standard



eis.apitech.com/plate

Filtered Terminal Blocks



Telecommunications equipment, industrial controls, power supplies, uninterruptible power supplies, military, instrumentation and power distribution equipment

- **Rugged construction**
Provides protection to filtering element; especially useful for repeated changes in field wiring
- **Design flexibility**
2 to 6 terminals available in "Barrier Strip" 2 to 12 terminals available in European variety
- **Performance**
Filter elements provide high insertion loss for EMI filtering of AC and DC power and control lines
- **Reliability**
Every terminal block is tested 100% for key parameters
- **European style blocks**
Available in English and metric spacing
- **FED/MIL approvals**
Barrier strips are recognized to U.L. 1059 file E133076 and approved by CSA Std 22.2 No. 158-1987 and ECN584B, LR92537; 52-160 series 100 VDC UL/CSA 52-257 series 250 VAC UL/CSA

- **Insertion loss range**
Effective insertion loss from 1 MHz to 18 GHz with proper installation
- **Capacitance**
2500 pF
- **Temperature range**
-55°C to +105°C
- **Voltage ratings (max.)**
Barrier: to 250 VAC
European: to 100 VDC
- **Current ratings (max.)**
Barrier: 30 Amps
European: 12 Amps



eis.apitech.com/block

Low Cost Ferrite Filtered D-Sub Connectors



Personal computers, microcomputers-applied products, peripheral/terminal equipment, industrial process equipment, cellular base stations, PBX telecommunications equipment, graphics workstations, and medical electronics

- **Cost-effective solutions**
Low cost, high performance; replaces individual filters on PCB, saving cost and space
- **Design flexibility**
Available in 9, 15 and 25 lines standard density
- **Compact design**
Interchangeable with standard D-subminiature connectors
- **Performance**
Gold plated contacts
Superior filtering of high frequency interference; ground plane design provides superior EMI shielding
- **Reliability**
Each connector position is tested 100% for critical electrical parameters to ensure consistent performance
- **FED/MIL approvals**
UL 94V-0, UL/CSA recognized

- **Insertion loss range**
1 MHz to 5 GHz and beyond
- **Capacitance and temperature characteristics**
To 120 pF – 1500 pF
- **Temperature range**
-40°C to +125°C
- **Voltage ratings (max.)**
500 VDC
- **Current ratings (max.)**
5 Amps



eis.apitech.com/series100

High Performance Filtered D-Subminiature & Combo Connectors



Telecommunications equipment, cellular base stations, secure communications, medical electronics, industrial process equipment, microwave TX/RX, personal computers, graphics work-stations and aerospace applications

- **Excellent filtering**
Filter types include Pi or feed-through capacitors; signal, power contacts; groundplane design provides superior EMI shielding.
- **Design flexibility**
9 through 50 line construction, standard, high density, mixed pin loading & selectively loaded lines
- **Reliability**
Each connector position is tested 100% for critical electrical parameters to ensure consistent performance
- **Numerous options**
Hardware, mounting, waved metal gaskets, hooded strain reliefs, combined filter types and plating
- **FED/MIL approvals**
UL 94V-0, UL/CSA recognized

- **Insertion loss range**
1 MHz to 18 GHz and beyond
- **Capacitance and temperature characteristics**
To 5600 pF
NPO, X7R, Y5V, Z5U
- **Temperature range**
-55°C to +125°C
- **Voltage ratings (max.)**
200 VDC
- **Current ratings (max.)**
5 Amps



eis.apitech.com/filcon

Filtered Datacom Connectors



Data networking equipment, personal and industrial computers and peripherals, workstations, fax/modems, copy machines, original telephone manufacturing, medical equipment, broadband transmission equipment, bay connectorization and multiplexing

- **Cost-effective solutions**
Modular jack connectors filtered with ferrites
Miniature ribbon connectors and adapters with chip capacitors
Mini din receptacles filtered with ferrites
USB connectors with inductors or chip capacitors for filtering
- **Design flexibility**
Modular jack receptacles available in single or multipoint styles with various shielding options
Miniature ribbon connectors and adapters available in 50-line configurations with a variety of hardware options
Mini din receptacles available fully shielded with either straight or kink legs

- **Reliability**
Each connector position is tested 100% for critical electrical parameters
- **Insertion loss/ inductance range**
Effective insertion loss from 1 MHz to 18 GHz with proper installation
- **Capacitance**
Up to 820 pF
- **Temperature range**
-55°C to +125°C
- **Voltage ratings (max.)**
1000 VDC (miniature ribbon connectors)
500 VDC (modular jack connectors)
- **Current ratings (max.)**
5 Amps



eis.apitech.com/data

Electromagnetic Integrated Solutions Selection Guide

SPECIALTY CONNECTORS & CUSTOM CABLE ASSEMBLIES

Specialty Connectors



Commercial and military avionics, satellites, telecommunications, power supplies, electronic warfare, ground/air weapon systems and mining and oil drilling exploration

Custom Cable & Harnessing



Commercial and military avionics, telecommunications, industrial equipment, mining & oil exploration, medical equipment

- **Excellent filtering**
Tubular and planar filtered arrays using Pi, LC, T, and C circuits; TVS protection available
- **Design flexibility**
Filtered MIL-DTL-38999, MIL-DTL-83723, MIL-DTL-26482, MIL-DTL-24308, MIL-DTL-55116 as well as custom filtered connectors
- **Reliability**
Each connector position is tested 100% for critical electrical parameters
- **Specialty Unfiltered Connectors**
Built to MIL specifications, custom shells to fit available space. Integral strain relief. Power, signal & coax line combinations

- **Signal & Discrete Cables**
Point-to-point, multi-conductor, branched harness, flex, semi-rigid, rigid circuit card assembly
- **RF Cables**
Phase matching, rigid/semi-rigid cable, custom RF cable builder tool
- **Power Cables**
Cooper "Roughneck" 4/00 + power distribution cable fabrication
- **Interconnects**
Harnesses can include a wide range of interconnects both unfiltered or API - Spectrum filtered products, sensors & potentiometers
- **Manufacturing expertise**
Services include lead wire preparation, soldering & tinning, marking & ribbon cable processing

Overmolding - rapid custom mold development (2 weeks typical)
- **100% tested**
Continuity
Isolation (1500VDC)

- **Insertion loss range**
Effective insertion loss from 1 MHz to 18 GHz with proper installation
- **Capacitance and temperature characteristics**
To 0.1 µF
COG, X7R, Z5U
- **Temperature range**
-55°C to +125°C
- **Voltage ratings (max.)**
125 VAC @ 400 Hz
up to 1000 VDC

- **Standard assured**
All cable assemblies & harnessing built in accordance with WHMA-IPC-620 & J-Std-001
- **Printed circuit board assemblies** built in accordance with IPC-A-610
In house design & build
- **Wire processing range**
28AWG to 350MCM
- **Temperature range**
-55°C to +200°C
- **Current ratings (max.)**
To 750 Amps
- **Frequency ratings**
To 40 GHz

eis.apitech.com/circular

eis.apitech.com/harness

POWER FILTERS & FILM MODULES

High Current Feed-Through Filters



Cellular base stations, telephone racks, high current switch mode power supplies, power amplifiers and servers, industrial equipment and laser welders

- **Easy installation**
Bolt-in style, surface mount
- **Design flexibility**
Available with single, dual, triple and quad configurations, different stud lengths, mounting brackets hardware and EMI gasketing available
- **Performance**
Ideally suited to help meet NEBS, GR1089, and EN55022
- **Agency approvals**
Designed to meet agency approvals, some selected filters UL 1950 recognized, CSA C22.2 certified and TÜV approved
- **Custom options**
Custom interfacing, contact pins, wire leads, multiple outputs
- **Environmental**
Can be used in both indoor and outdoor applications

- **Current ratings (max)**
To 500 Amps
- **Voltage ratings (max)**
To 1000 VDC and to 240 VAC
- **Insertion loss range**
AC: 1 MHz to 1 GHz
DC: 150 KHz to 10 GHz
High performance options available with IL up to 100 dB
- **Temperature range**
-55°C to +125°C
- **Capacitance**
4.7µF max
Class Y2 and Y4 available

eis.apitech.com/sfilter



Power Entry Modules



Digital equipment, personal computers and peripherals, measuring instruments, home appliances, monitor and display units

- **Rugged construction**
Designed to perform in industrial environments
- **Design flexibility**
Available in PCB mount, bolt-in, and snap-in configurations, fast-on tab, solder lug or flying leads, Fused and Switched and Fused options available
- **Performance**
Ideally suited for products that must conform to FCC part 15 regulations
Meets over voltage of IEC 664 category II and complies with IEC 950
Metal case provides high performance
- **Agency approvals**
UL recognized, CSA certified, TÜV approved (tested and found to be in accordance with VDE 0565 Part 3)
- **Custom options**
Value added connectors, wire leads, ring terminals

- **Current ratings (max)**
Up to 15 Amps
Switched/Fused 2, 4, and 6 Amps
- **Voltage ratings (max)**
From DC to 250 VAC, 60 Hz
- **Insertion loss range**
Effective filtering from 100 KHz to 30 MHz
- **Temperature range**
-25°C to +85°C
- **Leakage current**
0.35 mA to 0.50 mA max for general purpose filters
0.005 mA to 0.10 mA max for medical filters

eis.apitech.com/pem



Power Line Filters & 3 Phase Power Line Filters



Digital equipment, personal computers and peripherals, measuring instruments, medical, industrial, telecommunications equipment, factory automation, UPS, vending machines, elevators, and switch mode power supplies, welders, appliances, inverters and converters

- **Rugged construction**
Designed to perform in industrial environments
- **Design flexibility**
Available with fast-on or bolt-in terminals
Single and dual stage
Delta and Wye configurations
- **Performance**
Ideally suited for products that must conform to FCC part 15 regulations
Both metal and plastic cases provide high performance
Excellent attenuation for high voltage impulse
- **Agency approvals**
Several styles are UL recognized, CSA certified, TÜV approved (tested and found to be in accordance with VDE 0565 Part 3)

- **Current ratings (max)**
1 Amp to 100 Amps
3 Amps to 200 Amps (3 Phase)
- **Voltage ratings (max)**
From 48 VDC to 250 VAC, 60 Hz
250 VAC to 440 VAC (3 Phase)
- **Insertion loss range**
Effective filtering from 100 KHz to 30 MHz
- **Temperature range**
-25°C to +85°C
-40°C to +85°C (3 Phase)
- **Leakage current**
0.35 mA to 3.0 mA max

eis.apitech.com/pline

Electromagnetic Integrated Solutions Selection Guide

POWER FILTERS & FILM MODULES

Military/Aerospace Multisection Filters & Custom Commercial Assemblies



Commercial and military avionics, satellites, secure communications, ruggedized computer, radar, electronic warfare and ground weapons systems, telecommunications, cellular base stations, medical equipment, telephone switching and traffic control systems

- **Rugged construction**
Metal enclosures built to withstand MIL-STD environmental conditions, designed to perform in industrial or military environments
- **Design flexibility**
Filters designed to meet customers' requirements
Transient protection
Circuit breakers
Voltage cut-off
Other options available
- **Performance**
Provides quick and economical solutions to meet customers' specific requirements
Increases speed-to-market and decreases development time
Designs optimized through EMC verification
- **Military approvals**
Available to meet MIL-PRF-15733 and MIL-STD-461
Military testing IAW MIL-STD-202, MIL-STD-105
Designed to meet NEBS and safety agency approvals
- **EMI design verification**
Equipment verification can be accomplished through Spectrum Control's EMI test lab

- **Current ratings (max)**
Up to 250 Amps
- **Voltage ratings (max)**
400 VDC and 250 VAC standard; custom voltage ratings available
- **Insertion loss range**
Effective filtering from 10 KHz to 10 GHz
- **Temperature range**
-55°C to +125°C
- **Leakage current**
Standard and low leakage designs available

Film Capacitors & Modules



Renewable energy conversion equipment; electric vehicle inverter and charger equipment; laser pulse power and radar systems; industrial welders, elevators and medical defibrillators; high voltage and aircraft power supplies and motor drives

- **Design flexibility**
Wide range of dielectrics: polypropylene, polyester (mylar), polyphenylene sulphide (PPS)
Variety of terminations: radial or axial leads, machined, stamped, lugs, PCB mount, threaded, inserts
Multiple enclosures: metal case, pre-molded plastic, wrap and fill
Hermetic, non-hermetic
Various geometries: cylindrical, flat, modular, oval-wound
Encapsulation options:
Dry or impregnated
Multitude of sizes: less than an inch to several cubic feet
- **Performance**
Deliver high DC current, high pulse capability, high stability, low self-inductance, and low ESR
- **Compact size**
- **Testing & Verification**
Simulation software replicates real work environment
In house testing and verification insures function and compliance

- **Voltage ratings**
AC: Up to 750 VAC
DC: Up to 20,000 VDC
- **Temperature range**
-55°C to +150°C
- **DF**
0.3% to 0.15% typical
- **IR**
3 GΩ min
- **Ripple currents**
Up to 400 arms



eis.apitech.com/power



eis.apitech.com/film

MAGNETICS

Current Transformers



- **Current Sensors**
Measures electrical current (AC & DC) and can transform current from high to low measurable values
Wide primary current range of 3.5 Amps to 800 Amps

- **High Frequency Current Transformers**
20 kHz-100 kHz operating frequency
Available totally encapsulated, with or without wound primary turns and loading resistor
Built to UL, MIL, VDE, CE specs, EMRL current transformers meet UL1244

- **Load Detector Current Sensors**
Innovative Snap-On load detectors mount on pre-wired systems without disrupting existing connections
Broad frequency response of 30Hz to 15 kHz
Measure currents up to 40 Amps RMS continuous and 120 Amps intermittent

Toroidal Power Transformers



- 50/60Hz, 5-15,000V (Europe ER series)
- 60 Hz 120V (U.S. FR series)
- 400Hz 115-230V (Military DR series)
- Lower magnetic leakage, lower electrical noise and mechanical hum

Laminate Power Transformers



- Value ranges from 3 VA to 100,000 VA
- Transform line voltage to any other voltage

Switch Mode Power Supply Inductors



- Filter inductors, toroidal current sense transformers and high frequency inverter transformers
- Performance verified in 25kHz power supply
- 10 to 1,000 watts with low power losses

Power Inductors/Chokes



- Precision wound heavy-duty toroidal inductors
- Up to 100 amps, standard
- Lighting dimmers – low wattage residential to higher wattage commercial, motor controls, SCR controls and line filters

Lighting Chokes & Inductor/Filters



- Precision wound heavy-duty toroidal inductors
- 120 volt models from 12.5 to 100 Amps
- 240 volt models from 8.3 to 60 Amps

Modem & Module Transformers

- Broadband and voiceband transformers used for datacom and telecom applications
- xDSL, T1/E1, T3/DS3/E3/STS-1, ISDN interface modules
- ADSL / POTS splitter modules
- Impedance and line matching transformers

Custom designs available for all magnetics



eis.apitech.com/magnetics



eis.apitech.com/magnetics

ceramic capacitors



api 
technologies corp.
Spectrum Control

Ceramic Capacitors

we offer performance and cost alternatives to meet varied voltage, capacitance, packaging and budgetary requirements

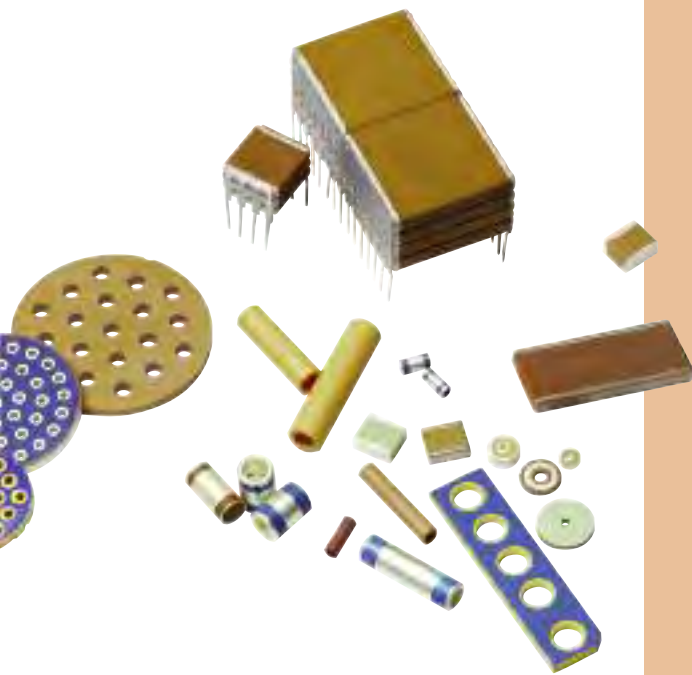

Discoidal Feed-Through Capacitors are ideal for by-pass and filtering applications with a low inductance construction suited for high frequency applications. Their low profile and rugged design is an excellent alternative to ceramic tubes... **CC3-CC7**

Tubular Feed-Through Capacitors are small and lightweight with high dielectric strength and are impervious to moisture and contamination. Feed-through capacitors have a uniform insertion loss over a broad spectrum range and are ideal for multi-pin connector applications... **CC8-CC9**

Tubular Pi Capacitors have similar characteristics to feed-through capacitors in addition to a narrower transition between the pass and stop bands, effectively stopping high frequency interference without affecting desired frequencies and providing filtering of noise content close to signal content ... **CC10-CC11**

SMPS (Switch Mode Power Supply) Capacitors deliver lower equivalent series resistance, lower equivalent series inductance, lower ripple voltage and less self-heating when compared to other capacitive elements... **CC13-CC15**

Planar Capacitors offer a faster assembly time compared to stand-alone chips, discoidal or tubular capacitors. They also have a low profile and are capable of meeting various geometric and electrical configurations, making Spectrum's planar capacitors the new standard in EMI suppression applications... **CC16**



API Technologies' Expertise

Inside every EMI filter is a ceramic feed-through capacitor. The Spectrum Control line of ceramic capacitors is designed to provide solutions to a wide range of filtering applications. Our ceramic capacitors are ideal for EMI/RFI suppression filters, medical implantable devices, commercial and military applications, power supplies and converters.

Custom Ceramic Capacitors

We offer many variations of discoidal, tubular and array capacitors to fit your custom application:

- Various OD, ID, thickness and length configurations
- Pressed discoidals with surface printed terminals
- Multi hole discoidal designs
- Miniature discoidals down to .080" OD
- Arrays
- Custom style capability
- High voltage designs available
- High temperature designs available
- Square tubes for surface mount applications
- Lapped feed-through capacitors

Discoidal Capacitors

Ceramic discoidal feed-through capacitors are the building blocks of the EMI filter industry. API's Spectrum Control discoidal capacitors provide great versatility in meeting varied voltage, capacitance and dimensional requirements. Our nonpolar, multilayer capacitors are small, reliable and high in dielectric strength. Operational temperatures of -55°C to $+125^{\circ}\text{C}$ are achieved with no voltage de-rating.

The versatile nature of our discoidals makes them ideally suited for by-pass and filtering applications. Due to their low inductance construction, these capacitors perform extremely well in high frequency applications. The circular geometry of a discoidal feed-through capacitor offers many paths to ground, resulting in lower impedance and better filtering performance.

The low profile and rugged design of our discoidal capacitors offer an excellent alternative to ceramic tubes.

Features

- Excellent high frequency performance
- Low profile design
- Rugged construction
- Low impedance, many paths to ground
- Low inductance, non-polar
- AC applications up to 240V
- DC applications up to 500V
- -55°C to $+125^{\circ}\text{C}$ operation

Feed-Through Circuit

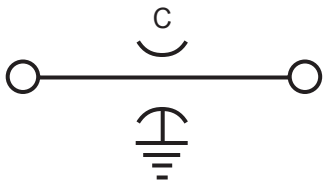

Specialty Ceramic Capacitors

We offer many variations of discoidal and array capacitors to fit your custom application:

- Various OD, ID and thickness configurations
- Pressed discoidals with surface printed terminals
- Multi-hole discoidal designs
- Miniature discoidals down to .080" OD
- Arrays
- Custom style capability
- High voltage designs available
- High temperature designs available



Multilayer Discoidal

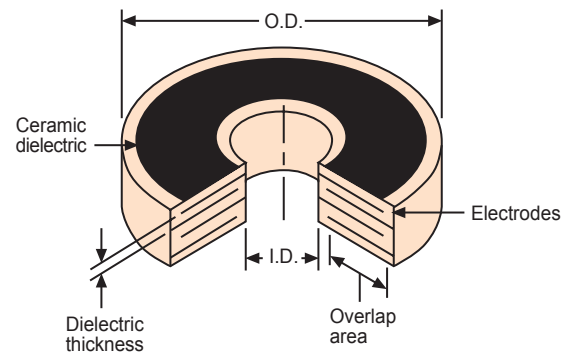

Insertion Loss

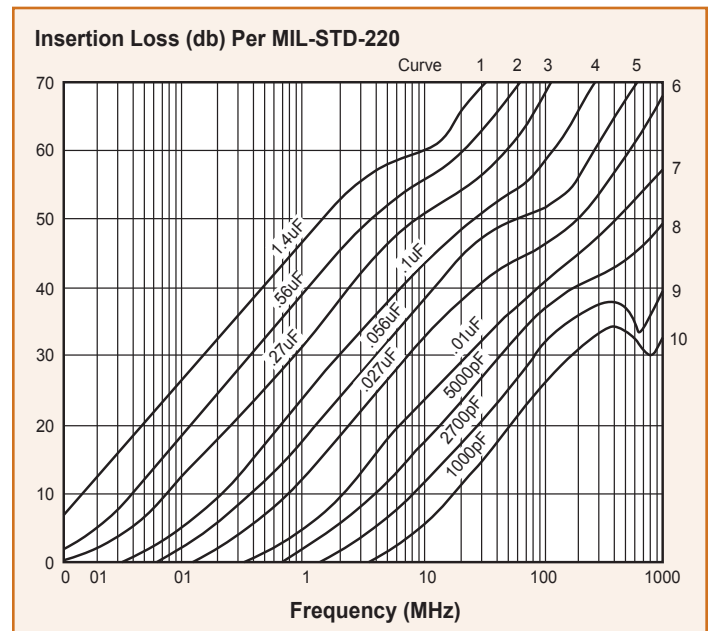

Metallization

Standard metallization is solderable silver. Other metallizations are available upon request.

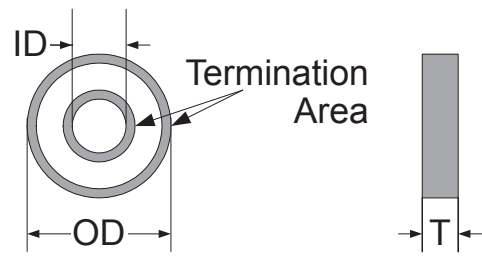

Discoidal NP0

| OD | (in) | 0.080 ±0.005 | 0.100 ±0.005 | 0.135 ±0.005 | 0.150 ±0.010 | 0.195 ±0.010 | 0.340 ±0.010 | 0.595 ±0.010 | | | | | | | | | | | | | | | | | | | |
|---------|---------|---------------------|---------------------|---------------------|---------------------|---------------------|---------------------|---------------------|----|-----|-----|-----|----|-----|-----|-----|----|-----|-----|-----|----|-----|-----|-----|----|--|--|
| | (mm) | 2.03 ±0.13 | 2.54 ±0.13 | 3.43 ±0.13 | 3.81 ±0.25 | 4.95 ±0.25 | 8.64 ±0.25 | 15.11 ±0.25 | | | | | | | | | | | | | | | | | | | |
| ID | (in) | 0.030 ±0.005 | 0.040 ±0.005 | 0.040 ±0.005 | 0.045 ±0.005 | 0.062 ±0.005 | 0.055 ±0.005 | 0.095 ±0.005 | | | | | | | | | | | | | | | | | | | |
| | (mm) | 0.76 ±0.13 | 1.02 ±0.13 | 1.02 ±0.13 | 1.14 ±0.13 | 1.52 ±0.13 | 1.40 ±0.13 | 2.41 ±0.13 | | | | | | | | | | | | | | | | | | | |
| T Max | (in) | 0.045 | 0.060 | 0.060 | 0.110 | 0.120 | 0.120 | 0.125 | | | | | | | | | | | | | | | | | | | |
| | (mm) | 1.14 | 1.52 | 1.52 | 2.79 | 3.05 | 3.05 | 3.18 | | | | | | | | | | | | | | | | | | | |
| Term BW | (in) | 0.000 - 0.015 | 0.000 - 0.020 | 0.000 - 0.025 | 0.000 - 0.025 | 0.002 - 0.025 | 0.005 - 0.045 | 0.005 - 0.055 | | | | | | | | | | | | | | | | | | | |
| | (mm) | 0.00 - 0.38 | 0.00 - 0.51 | 0.00 - 0.64 | 0.00 - 0.64 | 0.05 - 0.64 | 0.13 - 1.14 | 0.13 - 1.40 | | | | | | | | | | | | | | | | | | | |
| Cap(pF) | WV(VDC) | 500 | 200 | 100 | 50 | 500 | 200 | 100 | 50 | 500 | 200 | 100 | 50 | 500 | 200 | 100 | 50 | 500 | 200 | 100 | 50 | 500 | 200 | 100 | 50 | | |
| | 33 | | | | | | | | | | | | | | | | | | | | | | | | | | |
| 39 | | | | | | | | | | | | | | | | | | | | | | | | | | | |
| 47 | | | | | | | | | | | | | | | | | | | | | | | | | | | |
| 56 | | | | | | | | | | | | | | | | | | | | | | | | | | | |
| 68 | | | | | | | | | | | | | | | | | | | | | | | | | | | |
| 82 | | | | | | | | | | | | | | | | | | | | | | | | | | | |
| 100 | | | | | | | | | | | | | | | | | | | | | | | | | | | |
| 120 | | | | | | | | | | | | | | | | | | | | | | | | | | | |
| 150 | | | | | | | | | | | | | | | | | | | | | | | | | | | |
| 180 | | | | | | | | | | | | | | | | | | | | | | | | | | | |
| 220 | | | | | | | | | | | | | | | | | | | | | | | | | | | |
| 270 | | | | | | | | | | | | | | | | | | | | | | | | | | | |
| 330 | | | | | | | | | | | | | | | | | | | | | | | | | | | |
| 390 | | | | | | | | | | | | | | | | | | | | | | | | | | | |
| 470 | | | | | | | | | | | | | | | | | | | | | | | | | | | |
| 560 | | | | | | | | | | | | | | | | | | | | | | | | | | | |
| 680 | | | | | | | | | | | | | | | | | | | | | | | | | | | |
| 820 | | | | | | | | | | | | | | | | | | | | | | | | | | | |
| 1,000 | | | | | | | | | | | | | | | | | | | | | | | | | | | |
| 1,200 | | | | | | | | | | | | | | | | | | | | | | | | | | | |
| 1,500 | | | | | | | | | | | | | | | | | | | | | | | | | | | |
| 1,800 | | | | | | | | | | | | | | | | | | | | | | | | | | | |
| 2,200 | | | | | | | | | | | | | | | | | | | | | | | | | | | |
| 2,700 | | | | | | | | | | | | | | | | | | | | | | | | | | | |
| 3,300 | | | | | | | | | | | | | | | | | | | | | | | | | | | |
| 3,900 | | | | | | | | | | | | | | | | | | | | | | | | | | | |
| 4,700 | | | | | | | | | | | | | | | | | | | | | | | | | | | |
| 5,600 | | | | | | | | | | | | | | | | | | | | | | | | | | | |
| 6,800 | | | | | | | | | | | | | | | | | | | | | | | | | | | |
| 8,200 | | | | | | | | | | | | | | | | | | | | | | | | | | | |
| 10,000 | | | | | | | | | | | | | | | | | | | | | | | | | | | |
| 12,000 | | | | | | | | | | | | | | | | | | | | | | | | | | | |
| 15,000 | | | | | | | | | | | | | | | | | | | | | | | | | | | |
| 18,000 | | | | | | | | | | | | | | | | | | | | | | | | | | | |
| 22,000 | | | | | | | | | | | | | | | | | | | | | | | | | | | |
| 27,000 | | | | | | | | | | | | | | | | | | | | | | | | | | | |
| 33,000 | | | | | | | | | | | | | | | | | | | | | | | | | | | |
| 39,000 | | | | | | | | | | | | | | | | | | | | | | | | | | | |
| 47,000 | | | | | | | | | | | | | | | | | | | | | | | | | | | |
| 56,000 | | | | | | | | | | | | | | | | | | | | | | | | | | | |
| 68,000 | | | | | | | | | | | | | | | | | | | | | | | | | | | |
| 82,000 | | | | | | | | | | | | | | | | | | | | | | | | | | | |
| 100,000 | | | | | | | | | | | | | | | | | | | | | | | | | | | |
| 120,000 | | | | | | | | | | | | | | | | | | | | | | | | | | | |
| 150,000 | | | | | | | | | | | | | | | | | | | | | | | | | | | |
| 180,000 | | | | | | | | | | | | | | | | | | | | | | | | | | | |
| 220,000 | | | | | | | | | | | | | | | | | | | | | | | | | | | |
| 270,000 | | | | | | | | | | | | | | | | | | | | | | | | | | | |

Note: AC voltage determined upon request

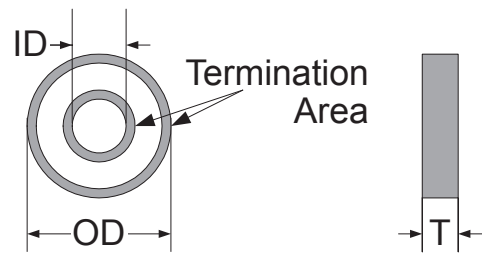

Discoidal X7R

| OD | (in) | 0.080 ±0.005 | | 0.100 ±0.005 | | 0.135 ±0.005 | | 0.150 ±0.010 | | 0.195 ±0.010 | | 0.340 ±0.010 | | 0.595 ±0.010 | | | | | | | | | | | |
|-----------|---------|---------------------|-----|---------------------|----|---------------------|-----|---------------------|----|---------------------|-----|---------------------|----|---------------------|-----|-----|----|-----|-----|-----|----|-----|-----|-----|----|
| | (mm) | 2.03 ±0.13 | | 2.54 ±0.13 | | 3.43 ±0.13 | | 3.81 ±0.25 | | 4.95 ±0.25 | | 8.64 ±0.25 | | 15.11 ±0.25 | | | | | | | | | | | |
| ID | (in) | 0.030 ±0.005 | | 0.040 ±0.005 | | 0.040 ±0.005 | | 0.045 ±0.005 | | 0.062 ±0.005 | | 0.055 ±0.005 | | 0.095 ±0.005 | | | | | | | | | | | |
| | (mm) | 0.76 ±0.13 | | 1.02 ±0.13 | | 1.02 ±0.13 | | 1.14 ±0.13 | | 1.52 ±0.13 | | 1.40 ±0.13 | | 2.41 ±0.13 | | | | | | | | | | | |
| T Max | (in) | 0.045 | | 0.060 | | 0.060 | | 0.110 | | 0.120 | | 0.120 | | 0.125 | | | | | | | | | | | |
| | (mm) | 1.14 | | 1.52 | | 1.52 | | 2.79 | | 3.05 | | 3.05 | | 3.18 | | | | | | | | | | | |
| Term BW | (in) | 0.000 - 0.015 | | 0.000 - 0.020 | | 0.000 - 0.025 | | 0.000 - 0.025 | | 0.002 - 0.025 | | 0.005 - 0.045 | | 0.005 - 0.055 | | | | | | | | | | | |
| | (mm) | 0.00 - 0.38 | | 0.00 - 0.51 | | 0.00 - 0.64 | | 0.00 - 0.64 | | 0.05 - 0.64 | | 0.13 - 1.14 | | 0.13 - 1.40 | | | | | | | | | | | |
| Cap(pF) | WV(VDC) | 500 | 200 | 100 | 50 | 500 | 200 | 100 | 50 | 500 | 200 | 100 | 50 | 500 | 200 | 100 | 50 | 500 | 200 | 100 | 50 | 500 | 200 | 100 | 50 |
| | | 1,000 | | | | | | | | | | | | | | | | | | | | | | | |
| 1,200 | | | | | | | | | | | | | | | | | | | | | | | | | |
| 1,500 | | | | | | | | | | | | | | | | | | | | | | | | | |
| 1,800 | | | | | | | | | | | | | | | | | | | | | | | | | |
| 2,200 | | | | | | | | | | | | | | | | | | | | | | | | | |
| 2,700 | | | | | | | | | | | | | | | | | | | | | | | | | |
| 3,300 | | | | | | | | | | | | | | | | | | | | | | | | | |
| 3,900 | | | | | | | | | | | | | | | | | | | | | | | | | |
| 4,700 | | | | | | | | | | | | | | | | | | | | | | | | | |
| 5,600 | | | | | | | | | | | | | | | | | | | | | | | | | |
| 6,800 | | | | | | | | | | | | | | | | | | | | | | | | | |
| 8,200 | | | | | | | | | | | | | | | | | | | | | | | | | |
| 10,000 | | | | | | | | | | | | | | | | | | | | | | | | | |
| 12,000 | | | | | | | | | | | | | | | | | | | | | | | | | |
| 15,000 | | | | | | | | | | | | | | | | | | | | | | | | | |
| 18,000 | | | | | | | | | | | | | | | | | | | | | | | | | |
| 22,000 | | | | | | | | | | | | | | | | | | | | | | | | | |
| 27,000 | | | | | | | | | | | | | | | | | | | | | | | | | |
| 33,000 | | | | | | | | | | | | | | | | | | | | | | | | | |
| 39,000 | | | | | | | | | | | | | | | | | | | | | | | | | |
| 47,000 | | | | | | | | | | | | | | | | | | | | | | | | | |
| 56,000 | | | | | | | | | | | | | | | | | | | | | | | | | |
| 68,000 | | | | | | | | | | | | | | | | | | | | | | | | | |
| 82,000 | | | | | | | | | | | | | | | | | | | | | | | | | |
| 100,000 | | | | | | | | | | | | | | | | | | | | | | | | | |
| 120,000 | | | | | | | | | | | | | | | | | | | | | | | | | |
| 150,000 | | | | | | | | | | | | | | | | | | | | | | | | | |
| 180,000 | | | | | | | | | | | | | | | | | | | | | | | | | |
| 220,000 | | | | | | | | | | | | | | | | | | | | | | | | | |
| 270,000 | | | | | | | | | | | | | | | | | | | | | | | | | |
| 330,000 | | | | | | | | | | | | | | | | | | | | | | | | | |
| 390,000 | | | | | | | | | | | | | | | | | | | | | | | | | |
| 470,000 | | | | | | | | | | | | | | | | | | | | | | | | | |
| 560,000 | | | | | | | | | | | | | | | | | | | | | | | | | |
| 680,000 | | | | | | | | | | | | | | | | | | | | | | | | | |
| 820,000 | | | | | | | | | | | | | | | | | | | | | | | | | |
| 1,000,000 | | | | | | | | | | | | | | | | | | | | | | | | | |
| 1,200,000 | | | | | | | | | | | | | | | | | | | | | | | | | |
| 1,500,000 | | | | | | | | | | | | | | | | | | | | | | | | | |
| 1,800,000 | | | | | | | | | | | | | | | | | | | | | | | | | |
| 2,200,000 | | | | | | | | | | | | | | | | | | | | | | | | | |
| 2,700,000 | | | | | | | | | | | | | | | | | | | | | | | | | |
| 3,300,000 | | | | | | | | | | | | | | | | | | | | | | | | | |
| 3,900,000 | | | | | | | | | | | | | | | | | | | | | | | | | |
| 6,800,000 | | | | | | | | | | | | | | | | | | | | | | | | | |

Note: AC voltage determined upon request

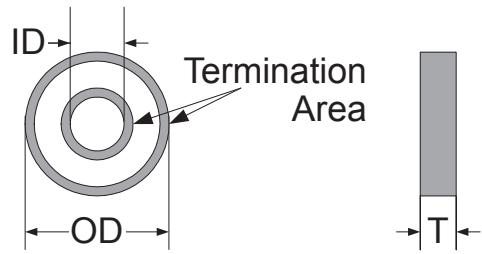

Discoidal Z5U

| OD | (in) | | 0.080 ±0.005 | | 0.100 ±0.005 | | 0.135 ±0.005 | | 0.150 ±0.010 | | 0.195 ±0.010 | | 0.340 ±0.010 | | 0.595 ±0.010 | | | |
|------------|---------|--|---------------------|--|---------------------|--|---------------------|--|---------------------|--|---------------------|--|---------------------|--|---------------------|--|----|--|
| | (mm) | | 2.03 ±0.13 | | 2.54 ±0.13 | | 3.43 ±0.13 | | 3.81 ±0.25 | | 4.95 ±0.25 | | 8.64 ±0.25 | | 15.11 ±0.25 | | | |
| ID | (in) | | 0.030 ±0.005 | | 0.040 ±0.005 | | 0.040 ±0.005 | | 0.045 ±0.005 | | 0.062 ±0.005 | | 0.055 ±0.005 | | 0.095 ±0.005 | | | |
| | (mm) | | 0.76 ±0.13 | | 1.02 ±0.13 | | 1.02 ±0.13 | | 1.14 ±0.13 | | 1.52 ±0.13 | | 1.40 ±0.13 | | 2.41 ±0.13 | | | |
| T Max | (in) | | 0.045 | | 0.060 | | 0.060 | | 0.110 | | 0.120 | | 0.120 | | 0.125 | | | |
| | (mm) | | 1.14 | | 1.52 | | 1.52 | | 2.79 | | 3.05 | | 3.05 | | 3.18 | | | |
| Term BW | (in) | | 0.000 - 0.015 | | 0.000 - 0.020 | | 0.000 - 0.025 | | 0.000 - 0.025 | | 0.002 - 0.025 | | 0.005 - 0.045 | | 0.005 - 0.055 | | | |
| | (mm) | | 0.00 - 0.38 | | 0.00 - 0.51 | | 0.00 - 0.64 | | 0.00 - 0.64 | | 0.05 - 0.64 | | 0.13 - 1.14 | | 0.13 - 1.40 | | | |
| Cap(pF) | WV(VDC) | | 500 | | 200 | | 100 | | 50 | | 500 | | 200 | | 100 | | 50 | |
| | 1,800 | | | | | | | | | | | | | | | | | |
| 2,200 | | | | | | | | | | | | | | | | | | |
| 2,700 | | | | | | | | | | | | | | | | | | |
| 3,300 | | | | | | | | | | | | | | | | | | |
| 3,900 | | | | | | | | | | | | | | | | | | |
| 4,700 | | | | | | | | | | | | | | | | | | |
| 5,600 | | | | | | | | | | | | | | | | | | |
| 6,800 | | | | | | | | | | | | | | | | | | |
| 8,200 | | | | | | | | | | | | | | | | | | |
| 10,000 | | | | | | | | | | | | | | | | | | |
| 12,000 | | | | | | | | | | | | | | | | | | |
| 15,000 | | | | | | | | | | | | | | | | | | |
| 18,000 | | | | | | | | | | | | | | | | | | |
| 22,000 | | | | | | | | | | | | | | | | | | |
| 27,000 | | | | | | | | | | | | | | | | | | |
| 33,000 | | | | | | | | | | | | | | | | | | |
| 39,000 | | | | | | | | | | | | | | | | | | |
| 47,000 | | | | | | | | | | | | | | | | | | |
| 56,000 | | | | | | | | | | | | | | | | | | |
| 68,000 | | | | | | | | | | | | | | | | | | |
| 82,000 | | | | | | | | | | | | | | | | | | |
| 100,000 | | | | | | | | | | | | | | | | | | |
| 120,000 | | | | | | | | | | | | | | | | | | |
| 150,000 | | | | | | | | | | | | | | | | | | |
| 180,000 | | | | | | | | | | | | | | | | | | |
| 220,000 | | | | | | | | | | | | | | | | | | |
| 270,000 | | | | | | | | | | | | | | | | | | |
| 330,000 | | | | | | | | | | | | | | | | | | |
| 390,000 | | | | | | | | | | | | | | | | | | |
| 470,000 | | | | | | | | | | | | | | | | | | |
| 560,000 | | | | | | | | | | | | | | | | | | |
| 680,000 | | | | | | | | | | | | | | | | | | |
| 820,000 | | | | | | | | | | | | | | | | | | |
| 1,000,000 | | | | | | | | | | | | | | | | | | |
| 1,200,000 | | | | | | | | | | | | | | | | | | |
| 1,500,000 | | | | | | | | | | | | | | | | | | |
| 1,800,000 | | | | | | | | | | | | | | | | | | |
| 2,200,000 | | | | | | | | | | | | | | | | | | |
| 2,700,000 | | | | | | | | | | | | | | | | | | |
| 3,300,000 | | | | | | | | | | | | | | | | | | |
| 3,900,000 | | | | | | | | | | | | | | | | | | |
| 6,800,000 | | | | | | | | | | | | | | | | | | |
| 8,200,000 | | | | | | | | | | | | | | | | | | |
| 10,000,000 | | | | | | | | | | | | | | | | | | |
| 12,000,000 | | | | | | | | | | | | | | | | | | |
| 15,000,000 | | | | | | | | | | | | | | | | | | |

Note: AC voltage determined upon request

Discoidal Electrical Testing

| Electrical Parameter | Test Method | Temperature Coefficient | | |
|---------------------------------|-------------------------|--|--|--|
| | | NP0 | X7R | Z5U |
| Temperature Coefficient | EIA 198 | ±30 ppm/ °C, - 55 to +125°C | ±15%, -55 to +125°C | +22, -56%, +10 to +85°C |
| Capacitance Tolerance | EIA Tolerance Code | K, M, P | K, M, P | M, P, Z |
| Capacitance Test@ 25°C | MIL-STD-202, Method 305 | Cap ≤ 100 pF: 1 MHz, 1 Vrms Cap > 100 pF: 1 KHz, 1 Vrms | 1 KHz, 1 Vrms | 1 KHz, 0.5 Vrms |
| Dissipation Factor @ 25°C | MIL-STD-202, Method 305 | 0.15% Max | 3.5% Max | 3.5% Max |
| Aging Rate (Per Decade) | | 0% | <2.0% | <3.5% |
| Insulation Resistance @ 25°C | MIL-STD-202, Method 302 | 1000 MΩ · μF or 100 KMΩ, whichever is less | 1000 MΩ · μF or 100 KMΩ, whichever is less | 1000 MΩ · μF or 100 KMΩ, whichever is less |
| Insulation Resistance @ 125°C | MIL-STD-202, Method 302 | 100 MΩ · μF or 10 KMΩ, whichever is less | 100 MΩ · μF or 10 KMΩ, whichever is less | 100 MΩ · μF or 10 KMΩ, whichever is less |
| Dielectric Withstanding Voltage | MIL-STD-202, Method 301 | 250% of Rated Voltage, 5 second hold, 30-50 mA | 250% of Rated Voltage, 5 second hold, 30-50 mA | 250% of Rated Voltage, 5 second hold, 30-50 mA |

Discoidal Part Numbering System

After determining the capacitor properties required for a given application, use information from pages AC4-7 and the part numbering system below to place the order. If there are any questions, do not hesitate to contact API's customer service.

Example: **340055AX145P6B0**

The part number shown represents a discoidal with an outer diameter of 0.340" and inner diameter of 0.055". The voltage rating for this part is 50 VDC. The ceramic type will be X7R. The capacitance value is 1,400,000 pF with a tolerance of +100, -0%. The termination will be silver and the parts will receive bulk packaging. Since the last identifier in the part number is "0", there are no special requirements.

| 340 | 055 | A | X | 145 | P | 6 | B | 0 |
|-----------------------|-----------------------|---|----------------------------|-----------------------------|--|--------------------|------------------|------------------------------------|
| Outer Diameter | Inner Diameter | Voltage Rating | Ceramic Code | EIA Cap Code | EIA Cap Tolerance | Termination | Packaging | Special Requirements |
| Example: 0.340" = 340 | Example: 0.055" = 055 | A: 50 VDC B: 100 VDC C: 200 VDC E: 500 VDC | N: NP0 X: X7R Z: Z5U | Example: 1,400,000 pF = 145 | K: ±10% M: ±20% P: +100 -0% Z: +80 -20% | 6: Silver | B: Bulk | 0: None D: Class B G: Custom |

Tubular FT Capacitors

API Technologies' Spectrum Control brand manufactures a wide variety of tubular feed-through (FT) ceramic capacitors, which are small in size, lightweight, nonpolar and offer high dielectric strength. Operating temperatures of -55°C to $+125^{\circ}\text{C}$ are achieved with no voltage de-rating. All capacitors are fired to produce true monolithic structures, which are impervious to moisture and contamination. Outer terminations feature a nickel barrier and a final metal layer, typically silver.

Feed-through tubular capacitors are ideally suited for by-pass and filtering applications. Due to the cylindrical design, the capacitors will have uniform insertion loss over a broad frequency range. This structure yields a low inductance when compared to conventional wound capacitors.

Solid FT capacitors have no internal electrodes and find their primary usage in low cost applications. Multilayered FT capacitors have a higher capacitance to volume ratio and are ideally suited for greater filtering at lower frequencies. Multilayered FT capacitors are also designed for applications where source impedances are high and sharp attenuation rise is critical.

Features

- Low cost solution for general purpose filtering
- Ideal for multi-pin connector applications
- High ratio of capacitance to volume
- Low inductance, non-polar
- Impervious to moisture and contamination
- -55°C to $+125^{\circ}\text{C}$ operation

Feed-Through Circuit

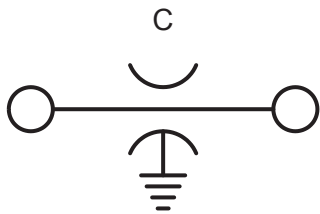

Feed-Through Construction

Solid

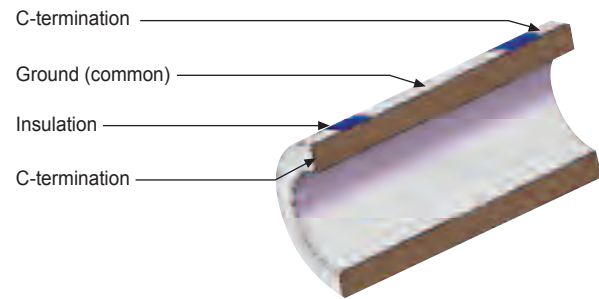

Multi Layered

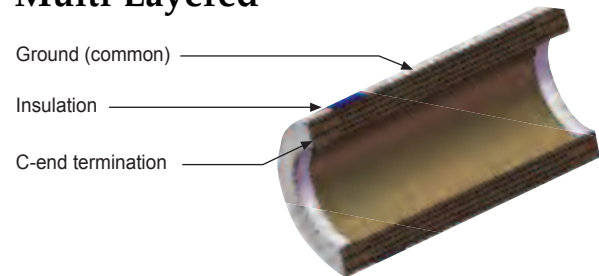

Insertion Loss

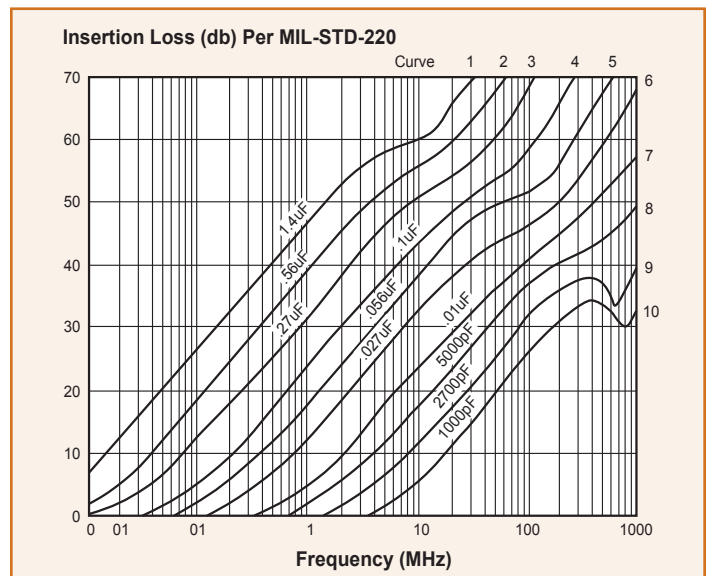

Tubular FT Specifications

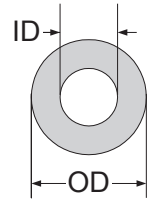
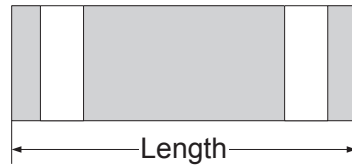

Banding Dimensions

| | | |
|-------------------------|--------|----------|
| Center Dimension, min. | 0.065" | 1.651 mm |
| Tip Dimension, min. | 0.002" | 0.051 mm |
| Bandwidth, 200 VDC min. | 0.025" | 0.635 mm |
| Bandwidth, 100 VDC min. | 0.020" | 0.508 mm |
| Bandwidth, 50 VDC min. | 0.015" | 0.381 mm |

| TCC | OD (in) | 0.081 ±0.002 | | | | | | 0.090 ±0.003 | | | | | | 0.122 ±0.004 | | | | | | | | |
|-------------|---------|--------------|--------|----|--------------|-----|----|--------------|-----|----|--------------|-----|----|--------------|-----|----|--------------|-----|----|--------------|-----|----|
| | | 2.06 ±0.05 | | | | | | 2.29 ±0.08 | | | | | | 3.10 ±0.10 | | | | | | | | |
| | ID (in) | 0.050 ±0.002 | | | | | | 0.060 ±0.003 | | | | | | 0.082 ±0.004 | | | | | | | | |
| Length (in) | (mm) | 0.173 ±0.010 | | | 0.235 ±0.010 | | | 0.173 ±0.010 | | | 0.235 ±0.010 | | | 0.300 ±0.010 | | | 0.315 ±0.010 | | | 0.250 ±0.010 | | |
| | | 4.39 ±0.25 | | | 5.97 ±0.25 | | | 4.39 ±0.25 | | | 5.97 ±0.25 | | | 7.62 ±0.25 | | | 8.00 ±0.25 | | | 6.35 ±0.25 | | |
| Cap(pF) | VV(VDC) | 200 | 100 | 50 | 200 | 100 | 50 | 200 | 100 | 50 | 200 | 100 | 50 | 200 | 100 | 50 | 200 | 100 | 50 | 200 | 100 | 50 |
| | | NP0 | 10 Max | | | | | | | | | | | | | | | | | | | |
| 12 | | | | | | | | | | | | | | | | | | | | | | |
| 27 | | | | | | | | | | | | | | | | | | | | | | |
| 33 | | | | | | | | | | | | | | | | | | | | | | |
| 39 | | | | | | | | | | | | | | | | | | | | | | |
| 47 | | | | | | | | | | | | | | | | | | | | | | |
| 56 | | | | | | | | | | | | | | | | | | | | | | |
| 68 | | | | | | | | | | | | | | | | | | | | | | |
| 82 | | | | | | | | | | | | | | | | | | | | | | |
| 100 | | | | | | | | | | | | | | | | | | | | | | |
| 120 | | | | | | | | | | | | | | | | | | | | | | |
| 150 | | | | | | | | | | | | | | | | | | | | | | |
| 180 | | | | | | | | | | | | | | | | | | | | | | |
| 220 | | | | | | | | | | | | | | | | | | | | | | |
| 270 | | | | | | | | | | | | | | | | | | | | | | |
| 330 | | | | | | | | | | | | | | | | | | | | | | |
| 390 | | | | | | | | | | | | | | | | | | | | | | |
| 470 | | | | | | | | | | | | | | | | | | | | | | |
| X7R | 330 | | | | | | | | | | | | | | | | | | | | | |
| | 390 | | | | | | | | | | | | | | | | | | | | | |
| | 470 | | | | | | | | | | | | | | | | | | | | | |
| | 560 | | | | | | | | | | | | | | | | | | | | | |
| | 680 | | | | | | | | | | | | | | | | | | | | | |
| | 820 | | | | | | | | | | | | | | | | | | | | | |
| | 1,000 | | | | | | | | | | | | | | | | | | | | | |
| | 1,200 | | | | | | | | | | | | | | | | | | | | | |
| | 1,500 | | | | | | | | | | | | | | | | | | | | | |
| | 1,800 | | | | | | | | | | | | | | | | | | | | | |
| | 2,200 | | | | | | | | | | | | | | | | | | | | | |
| | 2,700 | | | | | | | | | | | | | | | | | | | | | |
| | 3,300 | | | | | | | | | | | | | | | | | | | | | |
| | 3,900 | | | | | | | | | | | | | | | | | | | | | |
| 4,700 | | | | | | | | | | | | | | | | | | | | | | |
| 5,600 | | | | | | | | | | | | | | | | | | | | | | |
| 6,800 | | | | | | | | | | | | | | | | | | | | | | |
| 8,200 | | | | | | | | | | | | | | | | | | | | | | |
| 10,000 | | | | | | | | | | | | | | | | | | | | | | |
| 12,000 | | | | | | | | | | | | | | | | | | | | | | |
| 15,000 | | | | | | | | | | | | | | | | | | | | | | |
| 18,000 | | | | | | | | | | | | | | | | | | | | | | |
| 22,000 | | | | | | | | | | | | | | | | | | | | | | |
| 27,000 | | | | | | | | | | | | | | | | | | | | | | |
| Y5V | 3,300 | | | | | | | | | | | | | | | | | | | | | |
| | 3,900 | | | | | | | | | | | | | | | | | | | | | |
| | 4,700 | | | | | | | | | | | | | | | | | | | | | |
| | 5,600 | | | | | | | | | | | | | | | | | | | | | |
| | 6,800 | | | | | | | | | | | | | | | | | | | | | |
| | 8,200 | | | | | | | | | | | | | | | | | | | | | |
| | 10,000 | | | | | | | | | | | | | | | | | | | | | |
| | 12,000 | | | | | | | | | | | | | | | | | | | | | |

KEY: Solid Multi-layered

Tubular Pi Capacitors

As with the feed-through tubular capacitors, the Pi (π) tubular capacitors offered by API's Spectrum Control brand are small in size, lightweight, nonpolar and offer high dielectric strength. Operating temperatures of -55°C to $+125^{\circ}\text{C}$ are achieved with no voltage de-rating. All capacitors are fired to produce true monolithic structures, which are impervious to moisture and contamination. Outer terminations feature a nickel barrier and a final metal layer, typically silver.

Compared to feed-through tubular capacitors, Pi tubular capacitors have a much narrower transition between the pass and stop bands. Pi capacitors are effective in stopping high frequency interference without affecting necessary frequencies immediately below the stop band.

Similar to feed-through tubular capacitors, Pi tubular capacitors can be designed with a solid or multilayered configuration. Solid Pi tubular capacitors are more cost effective, but limited in capacitance values. Multilayered Pi tubular capacitors can cover a wider range of capacitance, while still maintaining the mechanical strength of a solid Pi tubular capacitor in a similar case size.

Features

- Provide filtering of noise content close to signal content
- Ideal for multi-pin connector applications
- High ratio of capacitance to volume
- Low inductance, nonpolar
- Impervious to moisture and contamination
- -55°C to $+125^{\circ}\text{C}$ operation

Pi Circuit

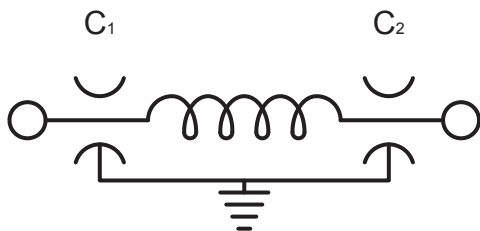

$C_1 + C_2 = C_{\text{Total}}$
Inductive Element not included.



Solid

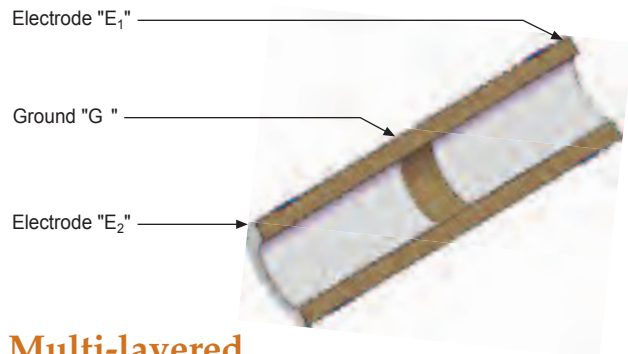

Multi-layered Tube

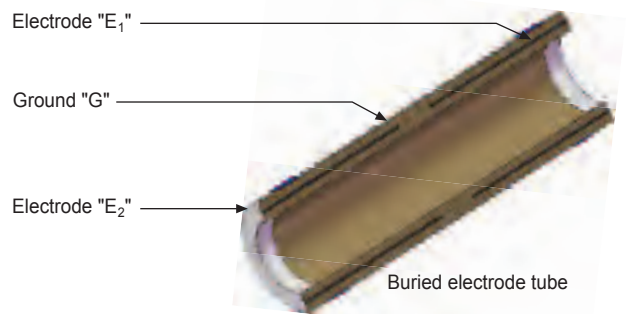

Insertion Loss

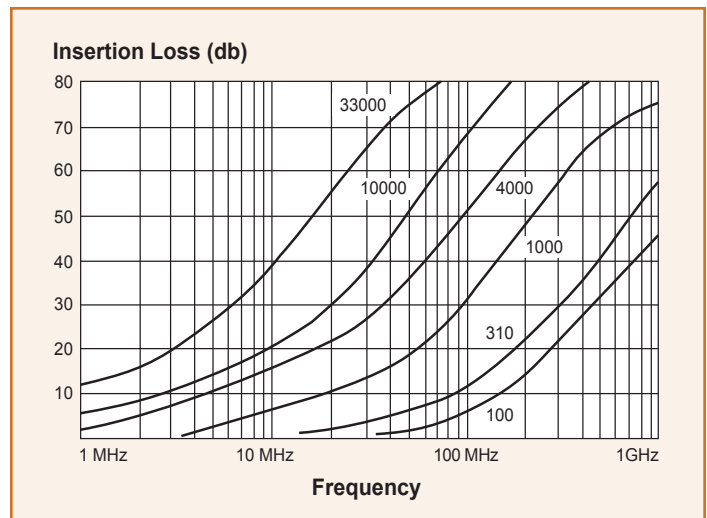

Tubular Pi Specifications

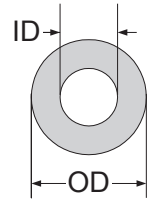
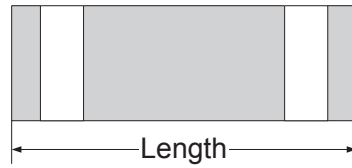

Banding Dimensions

| | | |
|-------------------------|--------|----------|
| Center Dimension, min. | 0.065" | 1.651 mm |
| Tip Dimension, min. | 0.002" | 0.051 mm |
| Bandwidth, 200 VDC min. | 0.025" | 0.635 mm |
| Bandwidth, 100 VDC min. | 0.020" | 0.508 mm |
| Bandwidth, 50 VDC min. | 0.015" | 0.381 mm |

| TCC | OD (in) | 0.081 ±0.002 | | | | | | 0.090 ±0.003 | | | | | | 0.122 ±0.004 | | | | | | | | |
|-------------|---------|--------------|--------|----|--------------|-----|----|--------------|-----|----|--------------|-----|----|--------------|-----|----|--------------|-----|----|--------------|-----|----|
| | | 2.06 ±0.05 | | | | | | 2.29 ±0.08 | | | | | | 3.10 ±0.10 | | | | | | | | |
| | ID (in) | 0.050 ±0.002 | | | | | | 0.060 ±0.003 | | | | | | 0.082 ±0.004 | | | | | | | | |
| Length (in) | (mm) | 0.173 ±0.010 | | | 0.235 ±0.010 | | | 0.173 ±0.010 | | | 0.235 ±0.010 | | | 0.300 ±0.010 | | | 0.315 ±0.010 | | | 0.250 ±0.010 | | |
| | | 4.39 ±0.25 | | | 5.97 ±0.25 | | | 4.39 ±0.25 | | | 5.97 ±0.25 | | | 7.62 ±0.25 | | | 8.00 ±0.25 | | | 6.35 ±0.25 | | |
| Cap(pF) | VV(VDC) | 200 | 100 | 50 | 200 | 100 | 50 | 200 | 100 | 50 | 200 | 100 | 50 | 200 | 100 | 50 | 200 | 100 | 50 | 200 | 100 | 50 |
| | | NP0 | 10 Max | | | | | | | | | | | | | | | | | | | |
| 12 | | | | | | | | | | | | | | | | | | | | | | |
| 27 | | | | | | | | | | | | | | | | | | | | | | |
| 33 | | | | | | | | | | | | | | | | | | | | | | |
| 39 | | | | | | | | | | | | | | | | | | | | | | |
| 47 | | | | | | | | | | | | | | | | | | | | | | |
| 56 | | | | | | | | | | | | | | | | | | | | | | |
| 68 | | | | | | | | | | | | | | | | | | | | | | |
| 82 | | | | | | | | | | | | | | | | | | | | | | |
| 100 | | | | | | | | | | | | | | | | | | | | | | |
| 120 | | | | | | | | | | | | | | | | | | | | | | |
| 150 | | | | | | | | | | | | | | | | | | | | | | |
| 180 | | | | | | | | | | | | | | | | | | | | | | |
| 220 | | | | | | | | | | | | | | | | | | | | | | |
| 270 | | | | | | | | | | | | | | | | | | | | | | |
| X7R | 180 | | | | | | | | | | | | | | | | | | | | | |
| | 220 | | | | | | | | | | | | | | | | | | | | | |
| | 270 | | | | | | | | | | | | | | | | | | | | | |
| | 330 | | | | | | | | | | | | | | | | | | | | | |
| | 390 | | | | | | | | | | | | | | | | | | | | | |
| | 470 | | | | | | | | | | | | | | | | | | | | | |
| | 560 | | | | | | | | | | | | | | | | | | | | | |
| | 680 | | | | | | | | | | | | | | | | | | | | | |
| | 820 | | | | | | | | | | | | | | | | | | | | | |
| | 1,000 | | | | | | | | | | | | | | | | | | | | | |
| | 1,200 | | | | | | | | | | | | | | | | | | | | | |
| | 1,500 | | | | | | | | | | | | | | | | | | | | | |
| | 1,800 | | | | | | | | | | | | | | | | | | | | | |
| | 2,200 | | | | | | | | | | | | | | | | | | | | | |
| | 2,700 | | | | | | | | | | | | | | | | | | | | | |
| 3,300 | | | | | | | | | | | | | | | | | | | | | | |
| 3,900 | | | | | | | | | | | | | | | | | | | | | | |
| 4,700 | | | | | | | | | | | | | | | | | | | | | | |
| 5,600 | | | | | | | | | | | | | | | | | | | | | | |
| 6,800 | | | | | | | | | | | | | | | | | | | | | | |
| 8,200 | | | | | | | | | | | | | | | | | | | | | | |
| 10,000 | | | | | | | | | | | | | | | | | | | | | | |
| 12,000 | | | | | | | | | | | | | | | | | | | | | | |
| 15,000 | | | | | | | | | | | | | | | | | | | | | | |
| Y5V | 1,800 | | | | | | | | | | | | | | | | | | | | | |
| | 2,200 | | | | | | | | | | | | | | | | | | | | | |
| | 2,700 | | | | | | | | | | | | | | | | | | | | | |
| | 3,300 | | | | | | | | | | | | | | | | | | | | | |
| | 3,900 | | | | | | | | | | | | | | | | | | | | | |
| | 4,700 | | | | | | | | | | | | | | | | | | | | | |
| | 5,600 | | | | | | | | | | | | | | | | | | | | | |
| | 6,800 | | | | | | | | | | | | | | | | | | | | | |
| | 8,200 | | | | | | | | | | | | | | | | | | | | | |
| | 10,000 | | | | | | | | | | | | | | | | | | | | | |
| 12,000 | | | | | | | | | | | | | | | | | | | | | | |
| 15,000 | | | | | | | | | | | | | | | | | | | | | | |
| 18,000 | | | | | | | | | | | | | | | | | | | | | | |
| 22,000 | | | | | | | | | | | | | | | | | | | | | | |
| 27,000 | | | | | | | | | | | | | | | | | | | | | | |

KEY: Solid Multi-Layered

General Tubular Capacitor Information



Specialty Tubular Products

We offer many variations of tubular capacitors to fit your custom application:

- Various OD, ID and length configurations
- Square tubes for surface mount applications
- Lapped feed-through capacitors
- Custom style capability

Tubular Electrical Testing

| Electrical Parameter | Test Method | Temperature Coefficient | | |
|---------------------------------|-------------------------|--|--|--|
| | | NP0 | X7R | Y5V |
| Temperature Coefficient | EIA 198 | ±30 ppm/ °C, - 55 to +125°C | ±15%, -55 to +125°C | +22, -82%, -30 to +85°C |
| Capacitance Tolerance | EIA Tolerance Code | M, P | N, P, Z | N, P, Z |
| Capacitance Test @ 25°C | MIL-STD-202, Method 305 | Cap ≤ 100 pF: 1 MHz, 1 Vrms Cap > 100 pF: 1 KHz, 1 Vrms | 1 KHz, 1 Vrms | 1 KHz, 1.0 Vms |
| Dissipation Factor @ 25°C | MIL-STD-202, Method 305 | 0.15% Max | 3.5% Max | 3.5% Max |
| Aging Rate (Per Decade) | | No Aging | <2.0% | <2.5% |
| Insulation Resistance @ 25°C | MIL-STD-202, Method 302 | 50 K Megohm or 500 Ohm-Farad, whichever is lower | 50 K Megohm or 500 Ohm-Farad, whichever is lower | 50 K Megohm or 500 Ohm-Farad, whichever is lower |
| Insulation Resistance @ 125°C | MIL-STD-202, Method 302 | 5 K Megohm or 50 Ohm-Farad, whichever is lower | 5 K Megohm or 50 Ohm-Farad, whichever is lower | 5 K Megohm or 50 Ohm-Farad, whichever is lower |
| Dielectric Withstanding Voltage | MIL-STD-202, Method 301 | 250% of Rated Voltage, 5 second hold, 30-50 mA | 250% of Rated Voltage, 5 second hold, 30-50 mA | 250% of Rated Voltage, 5 second hold, 30-50 mA |

Tubular Part Numbering System

After determining the capacitor properties required for a given application, use information from pages AC9-12 and the part numbering system below to place the order. If there are any questions, do not hesitate to contact API's customer service.

Example: I8150173X7R471M

The part number shown represents a Pi tubular capacitor with an outer diameter of 0.081" and inner diameter of 0.050". The voltage rating for this part is 200 VDC. The ceramic type will be X7R. The capacitance value is 470 pF with a tolerance of ±20%. The termination will be silver and the parts will receive bulk packaging.

| | | | | | | |
|--|-------------------------|-------------------------|--------------------------|---------------------|--------------------------|--|
| I | 81 | 50 | 173 | X7R | 471 | M |
| | | | | | | |
| Voltage Rating | Outer Diameter | Inner Diameter | Length | Ceramic Code | EIA Cap Code | EIA Cap Tolerance |
| A: FT, 50 VDC C: FT, 100 VDC E: FT, 200 VDC G: Pi, 50 VDC H: Pi, 100 VDC I: Pi, 200 VDC | Example: 0.081" = 81 | Example: 0.050" = 50 | Example: 0.173" = 173 | NP0 X7R Y5V | Example: 470 pF = 471 | M: ±20% N: ±30% P: +100 -0% Z: +80 -20% |

Mil Qualified & DSCC Certified SMPS Capacitor Assemblies



API Technologies' Spectrum Control line of MIL-PRF-49470 qualified and DSCC 87106 certified Switch Mode Power Supply capacitors are designed to provide superior performance in high frequency switching applications. These capacitors are ideal for high energy density products found in both military and commercial markets.

- Capacitance values 0.01µF to 47µF
- Leaded parts safeguard against thermal and mechanical stresses

API's High-speed SMPS capacitors have the following characteristics when compared to other capacitive elements:

- Lower Equivalent Series Resistance (ESR)
- Lower Equivalent Series Inductance (ESL)
- Lower ripple voltage and less self heating

Dielectric Characteristics

API offers SMPS capacitors in two basic dielectric classes, with individual designs tailored to meet specific performance characteristics.

| Dielectric Type | Stability Class | Description |
|------------------|----------------------|--|
| BP (NPO/COG) | Ultra Stable Class I | Effects on electrical properties are minimal with variations in operating temperature, voltage, frequency or time. Used in applications which require stable performance. |
| BQ, BR and BX | Stable Class II | Class II dielectrics will exhibit a predictable shift in performance characteristics when exposed to variations in temperature, voltage, frequency or time. Selected for applications where blocking, coupling, by-passing and frequency discriminating elements are used. Offers higher capacitance than Class I (COG). |

| Style/Size | Dimensions | | | | | Leads/Side |
|--------------------|----------------|----------------|----------------|----------------|----------------|------------|
| | A max | B max | C ±0.025" | D ±0.025" | E max | |
| SMP-3 (in) (mm) | 0.650 16.50 | 0.715 18.16 | 0.450 11.42 | 1.050 26.65 | 0.500 12.69 | 10 |
| SMP-4 (in) (mm) | 0.650 16.50 | 0.715 18.16 | 0.400 10.15 | 0.400 10.15 | 0.440 11.17 | 4 |
| SMP-5 (in) (mm) | 0.650 16.50 | 0.715 18.16 | 0.250 6.35 | 0.250 6.35 | 0.300 7.62 | 3 |

N Lead Configuration

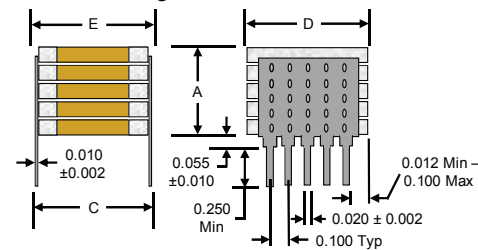

L Lead Configuration

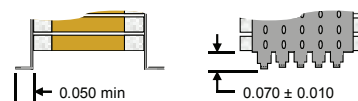

J Lead Configuration

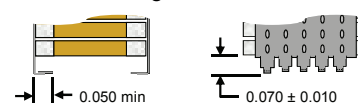

6/M Surface Mount Configuration



SMPS Part Numbering System

Example: **SMP3X124KENMB00**

The part number shown represents a size 3 SMPS capacitor. The ceramic type will be BX, capacitance value is 120,000 pF, with a tolerance of ±10%. The voltage rating is 500 VDC, termination will be "N" style leads and the parts will receive marking/ bulk packaging.

| SMP3 | X | 124 | K | E | N | M | B | 00 |
|----------------------|----------------------------------|------------------------|------------------------------|--|--|--------------------------|--|--------------------------------|
| Case Size | Ceramic Code | EIA Cap Code | EIA Cap Tolerance | Voltage Rating | Termination | Marking | Packaging | Special Requirements |
| SMP3 SMP4 SMP5 | P: BP Q: BQ R: BR X: BX | Example: 120,000 pF | J: ±5% K: ±10% M: ±20% | Z: 25 VDC A: 50 VDC B: 100 VDC C: 200 VDC E: 500 VDC | J: Leads in L: Leads out N: Leads straight | M: Marked U: Unmarked | T: Tape & Reel F: Foam carrier/boxed W: Waffle | GA:87106 Group A HR:Hi-Rel* |

* HR: Hi-Rel designation reflects MIL-PRF-49470, level B, QPL approval

Military/Hi-Rel & Commercial/Industrial Grade SMPS Capacitor Assemblies

API Technologies' Spectrum Control brand offers high reliability/military grade and commercial/ industrial grade capacitors designed to provide superior performance in high frequency switch mode power supply applications. These capacitors are ideal for bulk capacitance and pulsing applications and are available in a range of different footprints and mounting configurations. The high reliability/military grade is based on the design principals and test requirements defined by MIL-PRF-49470.

- Leaded options safeguard against thermal and mechanical stresses in larger package sizes
- Capacitance values 0.01 μF to 150 μF
- Stable Class II, BX, BR, BQ and X7R dielectric materials offer reliable operation and predictable performance characteristics related to temperature, frequency and voltage

API's line of Spectrum Control high-speed Switch Mode Power Supply capacitors have the following characteristics when compared to other capacitor technologies:

- Lower Equivalent Series Resistance (ESR)
- Lower Equivalent Series Inductance (ESL)
- Lower ripple voltage and less self heating

Electrical Characteristics

| VTC | WVDC | Maximum Capacitance Value | | | | | | | | | |
|-----|------|---------------------------|------|------|------|------|------|------|------|------|-------|
| | | 2225 | 2425 | 3530 | 3640 | 3940 | 4540 | 5550 | 6560 | 7565 | 44105 |
| X7R | 50 | 156 | 156 | 276 | 396 | 476 | 566 | 826 | 127 | 157 | 157 |
| X7R | 100 | 685 | 685 | 126 | 186 | 206 | 256 | 396 | 566 | 686 | 586 |
| X7R | 200 | 475 | 475 | 685 | 825 | 106 | 126 | 156 | 256 | 336 | 276 |
| X7R | 500 | 155 | 155 | 275 | 395 | 395 | 475 | 685 | 825 | 126 | 126 |
| BX | 50 | 475 | 565 | 106 | 126 | 156 | 185 | 276 | 396 | 576 | 476 |
| BX | 100 | 215 | 335 | 475 | 575 | 825 | 825 | 125 | 186 | 226 | 276 |
| BR | 200 | 125 | 155 | 255 | 395 | 395 | 475 | 685 | 106 | 126 | 126 |
| BQ | 500 | 564 | 684 | 125 | 155 | 185 | 185 | 275 | 475 | 565 | 565 |

Dimensions (Refer to drawings on page 14)

| Dimensions in (mm) | Case Size | | | | | | | | | |
|--------------------------|----------------------------|----------------------------|----------------------------|-----------------------------|-----------------------------|-----------------------------|------------------------------|------------------------------|------------------------------|------------------------------|
| | 2225 | 2425 | 3530 | 3640 | 3940 | 4540 | 5550 | 6560 | 7565 | 44A5 |
| C ± 0.025 (0.635) | 0.235 (5.97) | 0.250 (6.35) | 0.360 (9.14) | 0.370 (9.40) | 0.400 (10.16) | 0.460 (11.68) | 0.560 (14.22) | 0.660 (16.76) | 0.760 (19.30) | 0.450 (11.42) |
| D Min - Max | 0.224-0.275 (5.69-6.99) | 0.224-0.275 (5.69-6.99) | 0.275-0.325 (6.99-8.26) | 0.350-0.425 (8.89-10.80) | 0.350-0.425 (8.89-10.80) | 0.350-0.425 (8.89-10.80) | 0.450-0.525 (11.43-13.34) | 0.550-0.625 (13.97-15.88) | 0.600-0.675 (15.24-17.15) | 0.950-1.075 (24.13-27.31) |
| E Max | 0.300 (7.62) | 0.300 (7.62) | 0.420 (4.67) | 0.430 (10.92) | 0.440 (11.17) | 0.530 (13.46) | 0.630 (16.00) | 0.730 (18.54) | 0.830 (21.08) | 0.500 (12.70) |
| A Max | 0.650 (16.51) | 0.650 (16.51) | 0.650 (16.51) | 0.650 (16.51) | 0.650 (16.51) | 0.650 (16.51) | 0.650 (16.51) | 0.650 (16.51) | 0.650 (16.51) | 0.650 (16.51) |
| # Leads/Side | 3 | 3 | 3 | 4 | 4 | 4 | 5 | 6 | 6 | 10 |

Note: C dimension for non-leaded chip capacitors equals dimension specified less the thickness of the leads or 0.020" total

SMPS Part Numbering System

Example: **2225X824KAJMBHR**

The part number shown represents a 2225 size SMPS capacitor. The ceramic type is X7R / BX, capacitance value is 0.82 μF , with a tolerance of $\pm 10\%$. The voltage rating is 50 VDC, termination is "J" style leads, Group A testing is M49470 Group A, Subgroups 1 & 2 and the parts will receive marking / bulk packaging.

| 2225 | X | 824 | K | A | J | M | B | HR |
|--|-----------------------------------|---|--------------------------------|---|--|--------------------------------|--|--|
| Case Size Ref Dimensions Table | Ceramic Code | EIA Cap Code | EIA Cap Tolerance | Working Voltage | Lead Configurations | Marking | Packaging | Special Requirements* |
| A: 1.0 B: 1.1 C: 1.2 D: 1.3 E: 1.4 F: 1.5 | B: X7R Q: BQ R: BR X: BX | 824= 820,000 pF= 0.82 μF 125= 1,200,000 pF= 1.2 μF 156= 15,000,000 pF= 15 μF | K: $\pm 10\%$ M: $\pm 20\%$ | A: 50 VDC B: 100 VDC C: 200 VDC E: 500 VDC | J: Leads in L: Leads out N: Leads straight 6: Ag termination M: PdAg termination | M: Marked U: Unmarked (Std) | B: Bulk F: Foam carrier/boxed S: Special T: Tape & Reel - 7 in W: Waffle | 00: Standard HR: M49470 XX: Custom |
| For dimensions $\geq 1.000"$ Substitute letters above eg. 44A5 = 44105 chip size | | | | | | | | |

* 00 Designation reflects sample visual / mechanical inspection, plus 100% Capacitance, DF, DWV & IR testing @ +25°C
HR designation reflects Group A, Subgroups 1 & 2 inspection per MIL-PRF-49470

Additional package sizes, capacitance values and higher voltage ratings available, please contact factory.

SMPS Specifications

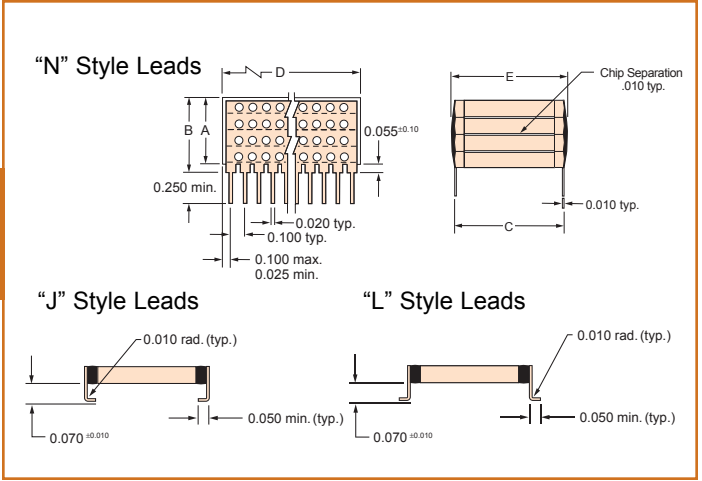

| Cap Value (µF) | BP | | | | BX | | | | BR | | | | BQ | | | |
|----------------|------------------|-----|-----|----|------------------|-----|-----|----|------------------|-----|-----|----|------------------|-----|-----|----|
| | Working Volts DC | | | | Working Volts DC | | | | Working Volts DC | | | | Working Volts DC | | | |
| | 500 | 200 | 100 | 50 | 500 | 200 | 100 | 50 | 500 | 200 | 100 | 50 | 500 | 200 | 100 | 50 |
| 0.01 | | | | | | | | | | | | | | | | |
| 0.012 | | | | | | | | | | | | | | | | |
| 0.015 | | | | | | | | | | | | | | | | |
| 0.018 | | | | | | | | | | | | | | | | |
| 0.022 | | | | | | | | | | | | | | | | |
| 0.027 | | | | | | | | | | | | | | | | |
| 0.033 | | | | | | | | | | | | | | | | |
| 0.039 | | | | | | | | | | | | | | | | |
| 0.047 | | | | | | | | | | | | | | | | |
| 0.056 | | | | | | | | | | | | | | | | |
| 0.068 | | | | | | | | | | | | | | | | |
| 0.082 | | | | | | | | | | | | | | | | |
| 0.10 | | | | | | | | | | | | | | | | |
| 0.12 | | | | | | | | | | | | | | | | |
| 0.15 | | | | | | | | | | | | | | | | |
| 0.18 | | | | | | | | | | | | | | | | |
| 0.22 | | | | | | | | | | | | | | | | |
| 0.27 | | | | | | | | | | | | | | | | |
| 0.33 | | | | | | | | | | | | | | | | |
| 0.39 | | | | | | | | | | | | | | | | |
| 0.47 | | | | | | | | | | | | | | | | |
| 0.56 | | | | | | | | | | | | | | | | |
| 0.68 | | | | | | | | | | | | | | | | |
| 0.82 | | | | | | | | | | | | | | | | |
| 1 | | | | | | | | | | | | | | | | |
| 1.2 | | | | | | | | | | | | | | | | |
| 1.5 | | | | | | | | | | | | | | | | |
| 1.8 | | | | | | | | | | | | | | | | |
| 2.2 | | | | | | | | | | | | | | | | |
| 2.7 | | | | | | | | | | | | | | | | |
| 3.3 | | | | | | | | | | | | | | | | |
| 3.9 | | | | | | | | | | | | | | | | |
| 4.7 | | | | | | | | | | | | | | | | |
| 5.6 | | | | | | | | | | | | | | | | |
| 6.8 | | | | | | | | | | | | | | | | |
| 8.2 | | | | | | | | | | | | | | | | |
| 10 | | | | | | | | | | | | | | | | |
| 12 | | | | | | | | | | | | | | | | |
| 15 | | | | | | | | | | | | | | | | |
| 18 | | | | | | | | | | | | | | | | |
| 22 | | | | | | | | | | | | | | | | |
| 27 | | | | | | | | | | | | | | | | |
| 33 | | | | | | | | | | | | | | | | |
| 39 | | | | | | | | | | | | | | | | |
| 47 | | | | | | | | | | | | | | | | |

KEY: SMP-3 SMP-4 SMP-5

SMPS Capacitor Electrical Testing

Absolute Maximum Output Capacitance
Assuming no ESL and no ESR

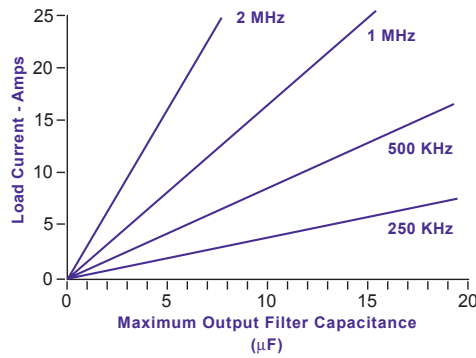

ESR vs. Frequency

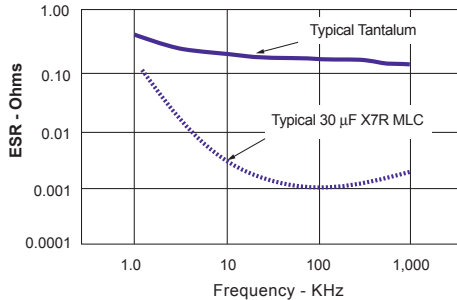

Absolute Maximum Capacitance ESL
Assuming no ESR - Capacitive Induced Ripple

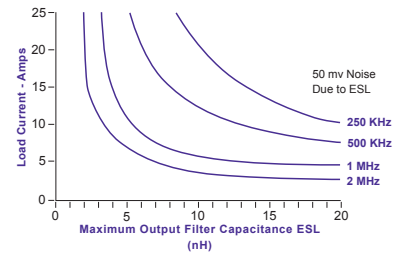

Impedance vs. Frequency

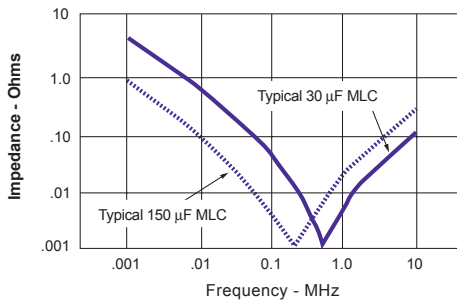

Absolute Maximum Capacitance ESR
Assuming no ESL - Capacitive Induced Ripple

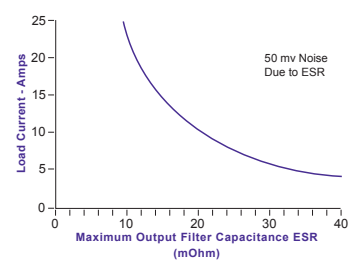

| Test Group | Test Order | Test | Test Method | Post Test Requirements | Sampling Procedure |
|------------------------|------------|--|---|---|--------------------------|
| Group A | 1 | Visual and Mechanical | | | 13 samples 0 failures |
| | 2 | Materials, Designs, Construction and Workmanship | | | |
| | 3 | Physical Dimensions and Marking | | | |
| | 4 | Capacitance and Dissipation Factor | MIL-STD-202 Method 305 | | 100% |
| | 5 | Dielectric Withstanding Voltage | MIL-STD-202 Method 301, 2.5x DCWV except 500V @ 1.5x | | |
| | 6 | Insulation Resistance | MIL-STD-202 Method 302 @ DCWV, 25 C | >100,000 megohms or 1,000 megohm-µF, whichever is less | |
| Group B Sub Grp I | 1 | Voltage and Temperature Limits | | | 12 samples 1 failure |
| | 2 | Resistance to Solvents | MIL-STD-202 Method 215 | | |
| | 3 | Immersion | MIL-STD-202 Method 104 test condition B | No mechanical damage. Dielectric strength, capacitance, df and 25 C IR to original limits | |
| | 4 | Terminal Strength | MIL-STD-202 Method 211 test condition A. Case codes 1-4, 6-5 lbs case code 5-4 lbs | No evidence of loosening or rupturing of terminals | |
| Group B Sub Grp II | 1 | Resistance to Soldering Heat | MIL-STD-202 Method 210 N lead style test condition B, J and L styles test condition I | No mechanical damage. Dielectric strength, capacitance, df and 25 C IR to original limits | 12 samples 1 failure |
| | 2 | Moisture Resistance | MIL-STD-202 Method 106, 20 cycles | No mechanical damage. Dielectric strength, capacitance, df and 25 C IR to original limits | |
| Group B Sub Grp III | 1 | Life | MIL-STD-202 Method 108, 1000 hrs. 2x DCWV except 1.2x 500 DCWV | No mechanical damage. Dielectric strength, capacitance, df, 125 C IR and 25 C IR to original limits | 12 samples 1 failure |
| Optional | | Solderability Group A | | | |
| | | Thermal Shock and Voltage Conditioning | | | |

Planar Capacitors



API Technologies' Spectrum Control brand designs and manufactures a wide range of planar capacitor arrays. Using over 25 years expertise in multilayer ceramic capacitor manufacturing, planar capacitors offer many advantages over stand-alone chip, discoidal or tubular capacitors: low profile, compact, quick assembly time. Various custom and industry standard geometries are available and our designs can incorporate multiple capacitance values, feed-through holes and ground holes. With a combination of versatility and function, API's planar capacitors are quickly becoming the new standard in filtered connectors used in EMI suppression applications.

Features

- Unparalleled electrical performance and reliability
- Fast prototyping and short lead times
- 100% electrical and dimensional testing of critical parameters
- Custom packaging to suit end user needs
- Custom and standard designs available

Mechanical Specifications

- Dielectrics:* EIA Codes: NP0 (COG), X7R, Z5U
- Termination:* Fired-on: silver, solderable silver plating: gold, silver or copper over nickel barrier
- Surface:* Lapped, termination bandwidth and insulative coating options
- Geometry:* Military circulars, D-Sub, ARINC, Micro-D, custom configurations
- Thickness:* Up to .150"

Electrical Specifications

- Operating Temperature* -55°C - 125°C
- Capacitance* Up to 1µF
- Capacitance Tolerance* ±10%, ±20%, +100%
- Capacitance Rating* Up to 1500VDC
- Dielectric Withstanding Voltage* Up to 3000VDC
- Dissipation Factor* < 3.5%
- Insulation Resistance* 1000 MΩ, µF or 10KMΩ

The electrical properties listed above are typical, and can be exceeded based on customer requirements and mechanical configuration. Since many variables affect the design, it is best to contact us directly for a detailed assessment of your planar capacitor needs.

Typical Design Layouts

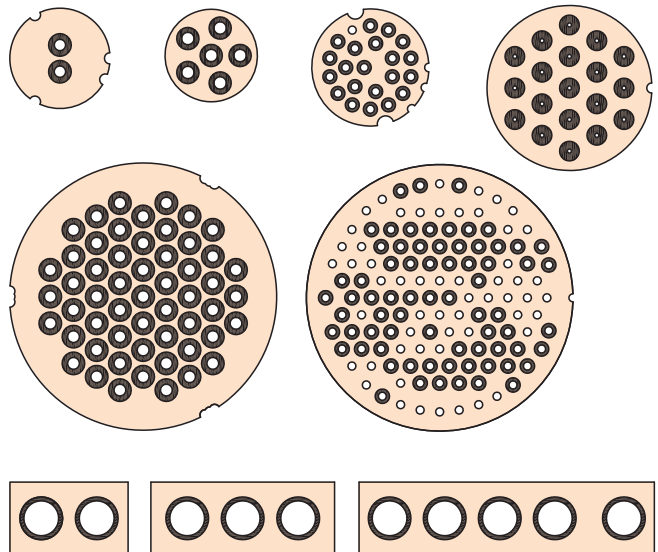

Dielectric Characteristics

Capacitor Selection

Multilayer capacitors (MLC) and single layer capacitors are categorized by performance with temperature. Component selection is typically determined by dielectric performance, electrical environment and temperature stability. In determining the proper component for a specific application, the following information should be considered.

Dielectric Type

There are three basic dielectric classes (characteristics) available:

DIELECTRIC PROPERTIES

| Dielectric Type | Stability Class | Description |
|-----------------------|-----------------------------|---|
| BP (NPO and COG) | Ultra Stable Class I | Effects on electrical properties are minimal with temperature, frequency or time. Used in applications which require stable performance. |
| BQ, BR, BX and X7R | Stable Class II | Effects on electrical properties predictably change with temperature, voltage, frequency and time. Selected for applications where blocking, coupling, by-passing and frequency discriminating elements are used. Offers higher capacitance than Class I (COG). |
| Z5U and Y5V | General Purpose Class II | Exhibits a greater variation of properties with temperature. Dielectric constant is higher than Class I and Class II dielectrics. Extremely high capacitance per unit volume and used in general performance applications. |

Dielectric Characteristics

NPO (COG)

| | |
|---------------------------------------|------------------------------------|
| Operating Temperature Range | -55°C to 125°C |
| Temperature Coefficient | 0 ± 30 ppm/°C |
| Dissipation Factor | .001 (0.1%) max. @ 25°C |
| Insulation Resistance: 25°C | 10 ⁶ Megohms |
| 125°C | 10 ⁵ Megohms |
| Dielectric Withstanding Voltage | 50 to 200V, 2.5 x VDCW |
| | 201 to 500V, 1.5 x VDCW, or 500V*, |
| | >500V, 1.2 VDCW, or 750V* |
| Aging Rate | 0% per decade hour |
| Test Parameters | 1 KHz, 1.0 ± 0.2 VRMS, 25°C |
| | 1 MHz for capacitance |
| | ≤1,000 pF |

* Whichever is greater

Capacitor Size

The capacitor body size impacts its utility to the design requirements in respect to capacitance value and voltage rating. Typically smaller units are less expensive and provide for greater space savings. Because mass affects the thermal response of the chips, size should be considered when selecting the attachment method to the circuit.

TERMINATION MATERIAL

| Material Type | Recommended Usage |
|------------------|--|
| Silver Palladium | Nonmagnetic application requirements. Recommended for conductive epoxy and leaded attachment methods. For soldering applications, use solder reflow below 230°C. |
| Silver | Most ductile of the available termination methods. Used in applications which will be leaded, to minimize thermal stresses. |

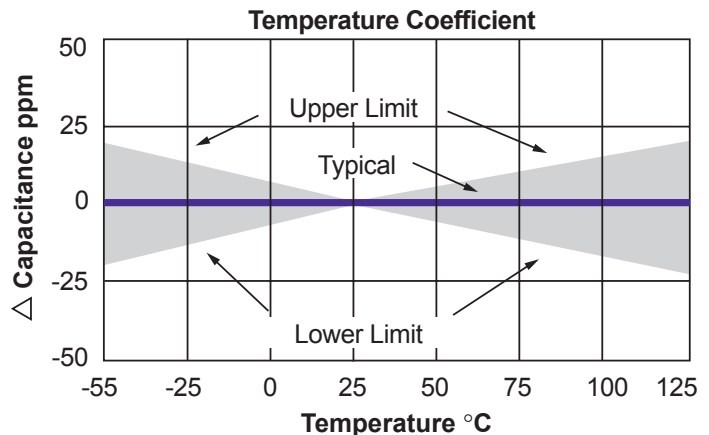

Dielectric Characteristics

Dielectric Characteristics Continued

X7R

| | |
|---------------------------------------|------------------------------------|
| Operating Temperature Range | -55°C to 125°C |
| Temperature Coefficient | ± 15% ΔC max. |
| Dissipation Factor | .025 (2.5%) max. @ 25°C |
| Insulation Resistance: 25°C | 10 ⁶ Megohms |
| 125°C | 10 ⁵ Megohms |
| Dielectric Withstanding Voltage | 50 to 200V, 2.5 x VDCW |
| | 201 to 500V, 1.5 x VDCW, or 500V*, |
| | >500V, 1.2 VDCW, or 750V* |
| Aging Rate | <2.0% per decade hour |
| Test Parameters | 1 KHZ, 1.0 VRMS ± 0.2 VRMS, 25°C |

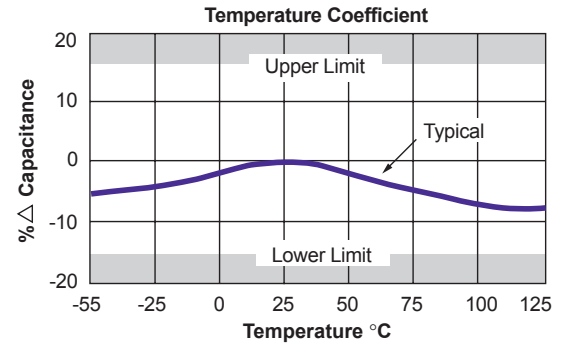

BX

| | |
|---------------------------------------|------------------------------------|
| Operating Temperature Range | -55°C to 125°C |
| Temperature Coefficient | ± 15% ΔC max. |
| Temperature Voltage Coefficient | + 15% - 25% ΔC max. |
| Dissipation Factor | .025 (2.5%) max. @ 25°C |
| Insulation Resistance: 25°C | 10 ⁶ Megohms |
| 125°C | 10 ⁵ Megohms |
| Dielectric Withstanding Voltage | 50 to 200V, 2.5 x VDCW |
| | 201 to 500V, 1.5 x VDCW, or 500V*, |
| | >500V, 1.2 VDCW, or 750V* |
| Aging Rate | 2.0% per decade hour |
| Test Parameters | 1 KHZ, 1.0 VRMS ± 0.2 VRMS, 25°C |

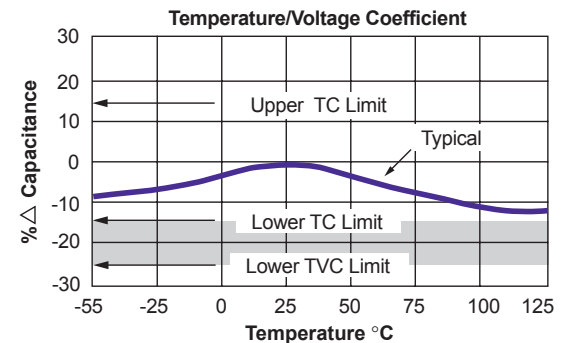

Z5U

| | |
|---------------------------------------|----------------------------------|
| Operating Temperature Range | +10°C to 85°C |
| Temperature Coefficient | + 22% - 56% ΔC max. |
| Dissipation Factor | .030 (3.0%) max. @ 25°C |
| Insulation Resistance: 25°C | 10 ⁵ Megohms |
| Dielectric Withstanding Voltage | 50 to 200V, 2.5 x VDCW |
| | 250V, 1.5 x VDCW |
| Aging Rate | -2.0% per decade hour |
| Test Parameters | 1 KHZ, 0.5 VRMS ± 0.1 VRMS, 25°C |

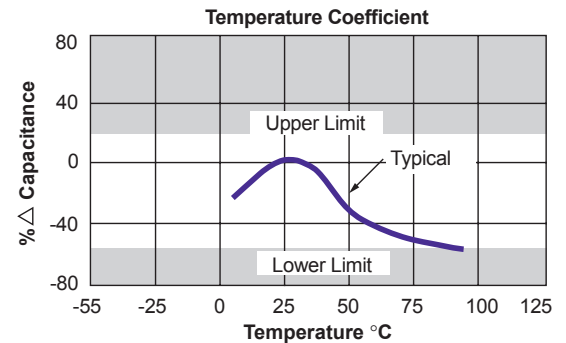

Y5V

| | |
|---------------------------------------|----------------------------------|
| Operating Temperature Range | -30°C to 85°C |
| Temperature Coefficient | + 22% - 82% ΔC max. |
| Dissipation Factor | .050 (5.0%) max. @ 25°C |
| Insulation Resistance: 25°C | 10 ⁵ Megohms |
| Dielectric Withstanding Voltage | 50 to 200V, 2.5 x VDCW |
| | 250V, 1.5 x VDCW |
| Aging Rate | -2.0% per decade hour |
| Test Parameters | 1 KHZ, 1.0 VRMS ± 0.2 VRMS, 25°C |

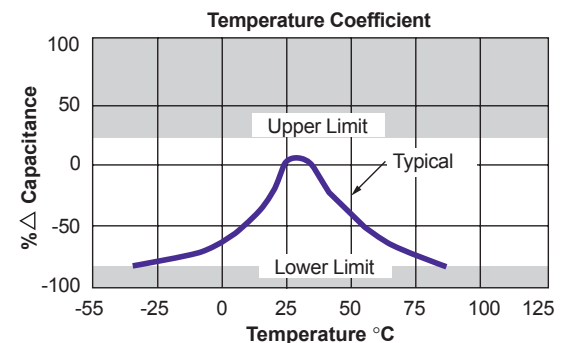

* Whichever is greater

Processing & Soldering Notes

General Soldering Recommendations for Leadless Ceramic Capacitors

Soldering Ceramic Capacitors with High Temperature Process

SN10 solder
Ramp rate, heating and cooling . . .approximately 30°C/min
Peak temperatureapproximately 320°C
Dwell at peak< 30 seconds
An RMA flux may be needed.

Soldering Ceramic Capacitors with Medium Temperature Process

SN96 solder
Ramp rate, heating and cooling....approximately 30°C/min
Peak temperatureapproximately 250°C
Dwell at peak< 30 seconds

Soldering Ceramic Capacitors with Low Temperature Process

SN62 solder
Ramp rate, heating and cooling....approximately 30°C/min
Peak temperatureapproximately 220°C
Dwell at peak< 30 seconds

Notes

Care must be taken to minimize the time silver terminations are exposed to molten solder to avoid leaching (amalgamation of the silver into molten solder). API recommends the use of a silver (Ag) bearing solder when terminating directly to ceramic capacitors to reduce the potential for leaching. Gradual heating and cooling of the components are essential to prevent thermal stresses to the ceramic.

Application Note: Soldering Recommendations for Switch Mode Power Supply Capacitors

- SMPS capacitors are highly durable structures designed to provide long service per lifetime, however they require attention to basic considerations during assembly. Like all ceramic components, SMPS capacitors are subject to thermal stresses. For this reason, preheating of the capacitor assemblies is recommended. Preheat components using hot plate to 120 to 150°C, or within 50 to 60°C of the soldering temperature being applied. Avoid over-exposure to high temperatures during assembly and allow for gradual, post-assembly cooling.
- For hand iron soldering, recommended soldering iron tip temperature is 330 to 350°C. Contact the pad adjacent to the pre-tinned lead should be made from below the PCB (opposite of the component side), and the dwell time on the solder joint should be less than five seconds. An aluminum heat sink plate may be placed adjacent to the SMPS lead frame to protect the ceramic body during assembly. Avoid direct contact between soldering iron and ceramic during assembly process. Soldering time is dependant upon heat sinking provided by the chassis and board material, so a longer preheat cycle may be required.
- Standard solders (Sn60, Sn63, Sn60/38/2) may be used. Please consult the factory for use with RoHS compliant solders.
- Use a controlled temperature profile ramp not exceeding 4°C per second as measured by an attached low mass thermocouple.
- Soldering time and temperatures can vary with component size, board material and layout. Please consult the factory for assistance.

coaxial filters & interconnects



api 
technologies corp.
Spectrum Control

Coaxial Filters & Interconnects

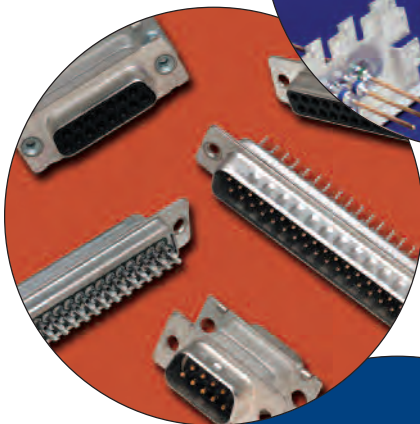
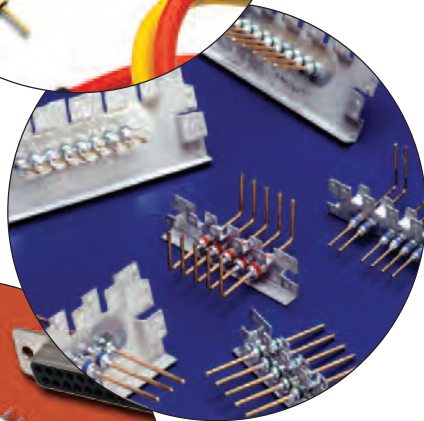
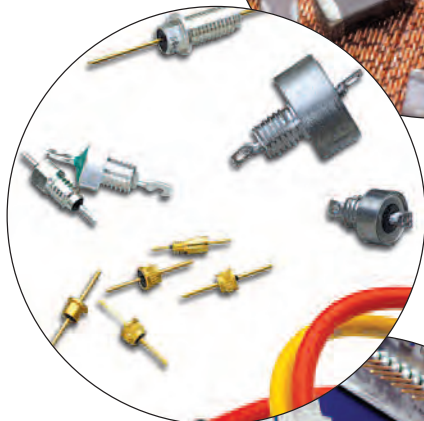
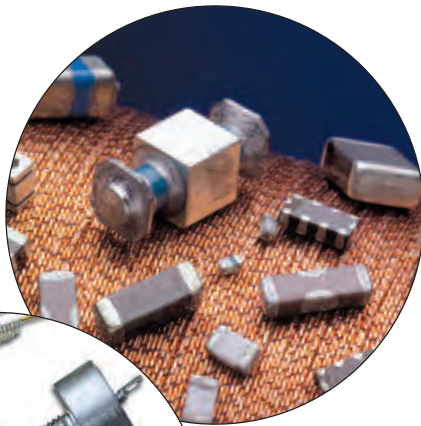

Introduction

| | |
|------------------------------------|-----------|
| Application Guidelines | CF3-CF8 |
| Military Cross Reference | CF9-CF11 |
| Amp Cross Reference | CF12-CF16 |

Surface Mount EMI Filters

| | |
|--|-----------|
| Three Terminal Chips | SM2-SM7 |
| SA Series Arrays | SM8-SM9 |
| MSM Mini-Surface Mount | SM11 |
| SSM Square Surface Mount | SM12-SM13 |
| PSM Power Surface Mount | SM14-SM15 |
| MSP Mini Surface Mount Power Filters | SM16 |
| MPC Series Miniature PCB Power Filters | SM17-SM20 |
| High Frequency PCB Filters | SM21 |

Low Pass EMI Filters

| | |
|--|-----------|
| Motor Line Feed-Through (MLFT) Filters | LP2 |
| Solder-in Filters | LP3-LP7 |
| 9900 Series Filters | LP8-LP11 |
| Spec Spin Filters | LP12 |
| Resin Sealed Filters | LP13-LP24 |
| High Current Resin Sealed Filters | LP25-LP26 |
| Hermetically Sealed Filters | LP27-LP42 |
| Value Added Assemblies | LP43 |

EMI Filtered Arrays

| | |
|--|-----------|
| Easy Mate® Filter Plates | FA3-FA8 |
| Bolt-In Filter Plates | FA9-FA12 |
| Shrouded Latch Filter Plates | FA13-FA14 |
| Barrier Strip Filtered Terminal Blocks | FA19-FA21 |
| Custom Filtered Arrays | FA22 |

EMI Filtered Connectors

| | |
|--|-----------|
| Series F Ferrite Filtered Connectors | FC3-FC7 |
| Series 500 Low-Profile Feed-Through Connectors | FC8-FC11 |
| Series 600 Hi-Density Filtered Connectors | FC12-FC13 |
| Series 700 High Performance Connectors | FC16-FC37 |
| Filtered Combo D-Sub Connectors | FC38-FC48 |
| Micro D Series Connectors | FC49-FC53 |
| Datacom Connectors | FC54-FC58 |
| USB Connectors | FC59 |
| Hooded Strain Reliefs | FC60 |

Quietshield™ Gaskets & Shielding

| | |
|-------------------------------------|-----------|
| Fabric-Over-Foam Gaskets | FC68-FC69 |
| I/O & Waved Metal Gaskets | FC70 |
| Shielding Tapes & Fabrics | FC71 |
| Wire Mesh Gaskets | FC72 |
| Conductive Silicone | FC73 |

Application Guidelines

Sources of EMI

Electromagnetic interference occurs naturally from terrestrial sources such as lightning discharges, precipitation, and sand and dust storms, in addition to cosmic noise emanating from sources within and outside our solar system. Man-made sources include power lines, rotating machinery, ignition systems, television and radio receivers, fluorescent lights, power amplifiers, computing devices and transmitters of all types.

Interference Suppression

Filter networks suppress electromagnetic interference in two basic ways. The capacitor elements shunt the interference to ground, and the series inductor elements raise the impedance of the line making the shunt capacitor elements even more effective.

Capacitor Elements

The types of capacitors used in API's line of Spectrum Control filters are often referred to as feed-through capacitors due to their physical geometry.

The feed-through design results in greatly reduced self-inductance compared to standard leaded capacitors. Also, this design effectively prevents radiation from the input coupling directly with the output of the capacitor, unlike leaded or chip capacitors. The combination of low inductance and high input/output isolation provides excellent shunting of EMI for frequencies up to and beyond 1 GHz.

The simplest feed-through type is a ceramic tube that may have buried electrodes and can be constructed as a single capacitor or as two capacitors, as used in a Pi section filter. This type of device can have capacitance values from 10 pF to 0.1 μ F and typical working voltage ratings up to 2500 VDC. Due to the simple construction, these capacitors are very efficient at frequencies up to 10 GHz and exhibit no pronounced resonances.

Multilayer monolithic discoidal capacitors are used for very high capacitance parts in standard sizes or for smaller filters where the required capacitance cannot be achieved by a ceramic tube. This type of capacitor consists of alternate layers of opposite polarity electrodes separated by a ceramic dielectric. Typical capacitance values from 100 pF to 10 μ F are available with working voltages up to 400 VDC.

Inductive Elements

Ferrite sleeves are used with tubular capacitors since they can be conveniently accommodated inside the tube to provide a very compact filter. They are also used with discoidal capacitors in some applications. Wound inductors are used with discoidal capacitors to provide very high performance filters.

Multilayer Discoidal Capacitor

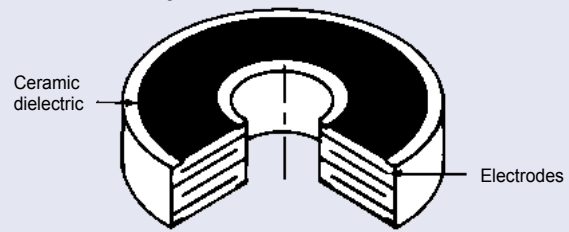

Embedded Electrode Tubular Capacitor

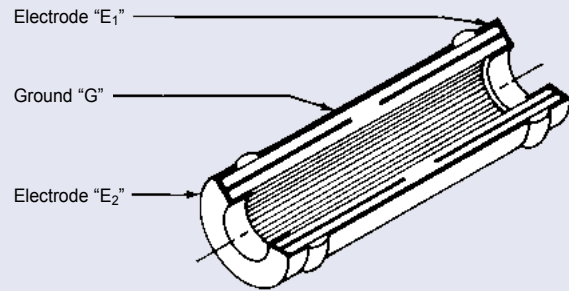

Resin Sealed Filter

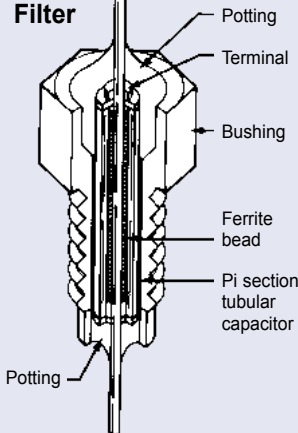

Hermetically Sealed Filter

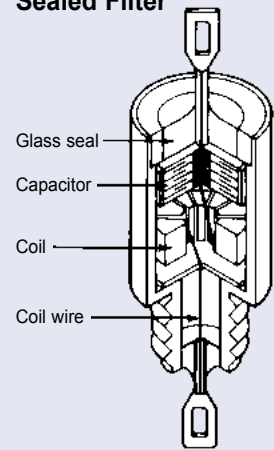

Circular Filtered Connector

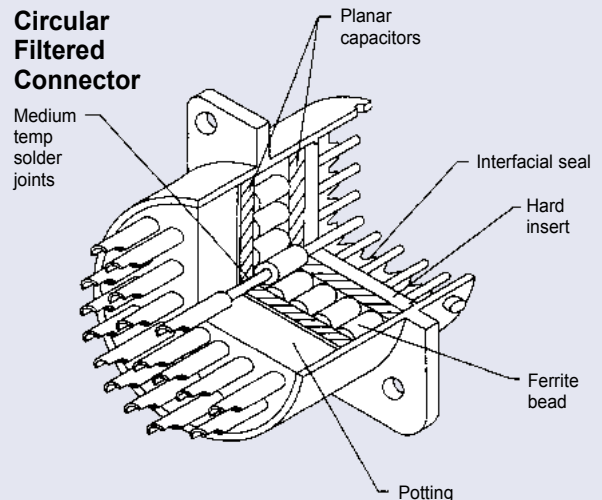

Application Guidelines

Low Pass EMI filters are available in the following circuit configurations:

C Filter

The C filter is a three terminal feed-through capacitor. It is used to attenuate high frequency signals.

L Filter

An L filter consists of one inductive element and one capacitive element. This type of filter can offer high impedance or low impedance input depending upon its orientation in the circuit. It is most commonly used in applications where one has a high impedance load and a low impedance source (see LT), or where one has a high impedance source and a low impedance load (see LB).

Pi Filter

The Pi filter contains two capacitive elements and one inductive element. It presents a low impedance to both the source and the load. Because of the additional element, it provides better high frequency performance than the C or L configurations. Due to the possibility of 'ringing', Pi filters are not recommended for switching applications.

Transient Suppression Pi Filter

The transient suppression Pi filter consists of a Pi filter with a transient suppressor at the input to the filter. The filter supplies the high frequency performance of the Pi filter with the added protection of the transient suppressor to protect the circuit from voltage spikes on the line.

T Filter

The T filter consists of two inductive elements and one capacitive element. This circuit configuration presents a high impedance input from either end. It has similar filter performance to the Pi circuit configurations. It does not have the ringing characteristic of the Pi filter and can be used in switching applications.

Multisection Filter (Double T)

API's multielement filters are designed for optimum insertion loss in circuits with a relatively low source and load impedance. These filters are also recommended in any application where a high degree of filtering is required. The unit utilizes an inductor input for the best compatibility with a MIL-STD-461 test setup (10 μ F feed-through capacitor).

Schematics

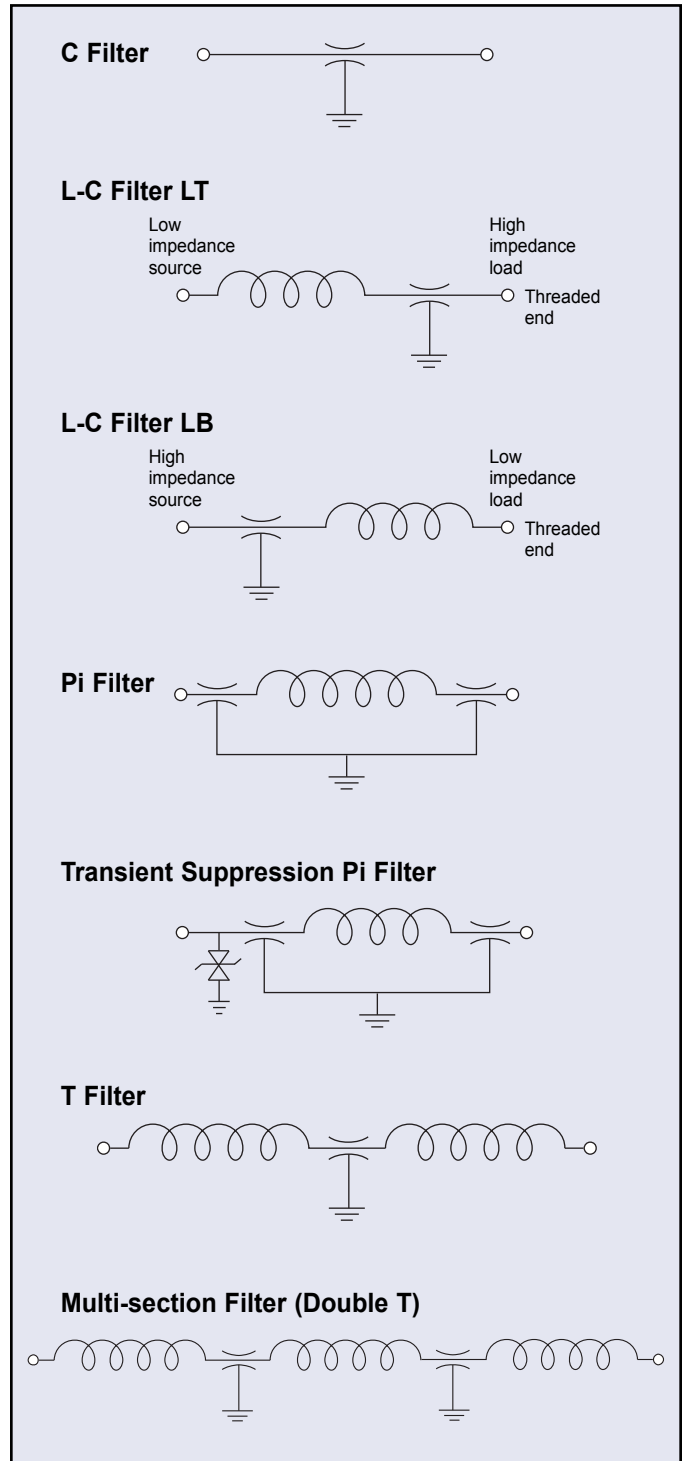

Application Guidelines

Insertion Loss Measurement

Insertion loss (IL) is a measure of the effectiveness of a filter. It is defined as the ratio of the voltage (E1) across the circuit load without the filter and the voltage (E2) across the load with the filter. Since insertion loss is dependent on the source and load impedance in which the filter is to be used, IL measurements are defined for a matched 50 ohm system. The insertion loss is measured in decibels (dB) and defined as follows:

$$IL \text{ (dB)} = 20 \log \left[\frac{E1}{E2} \right]$$

Circuit Impedance vs. Insertion Loss

In practical circuit applications the source and load impedances may be quite different from 50 ohms. If these impedances are known, API engineering can provide information on the expected insertion loss or an estimate can be made using the following formula:

$$IL \text{ (dB)} = 20 \log \left[1 + \frac{Z_s Z_l}{Z_t (Z_s + Z_l)} \right]$$

Where Z_s = Source impedance in ohms
 Z_l = Load impedance in ohms
 Z_t = Transfer impedance in 50 ohm system

Example:

1. System source and load impedances are 100 ohms and 600 ohms respectively.
2. Selected filter has insertion loss of 50 dB at 100 MHz in a 50 ohm system.
3. From the IL vs Transfer Impedance curve (right) the transfer impedance is 0.08 ohms.

$$4. IL = 20 \log \left[1 + \frac{100 \times 600}{0.08 (100+600)} \right]$$

$$= 20 \log 1072$$

$$= 61 \text{ dB}$$

Insertion Loss (dB)

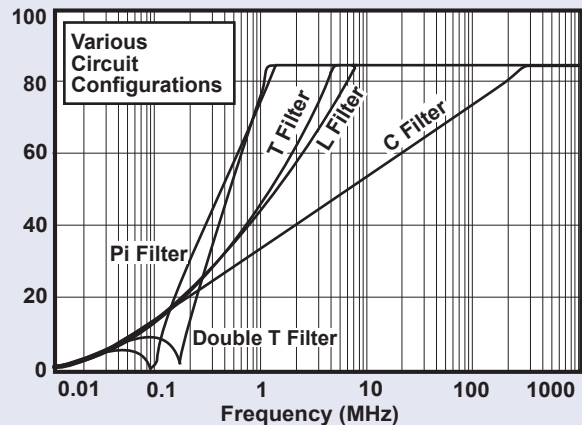
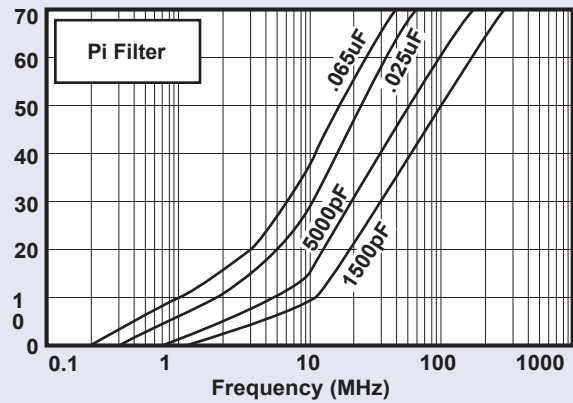
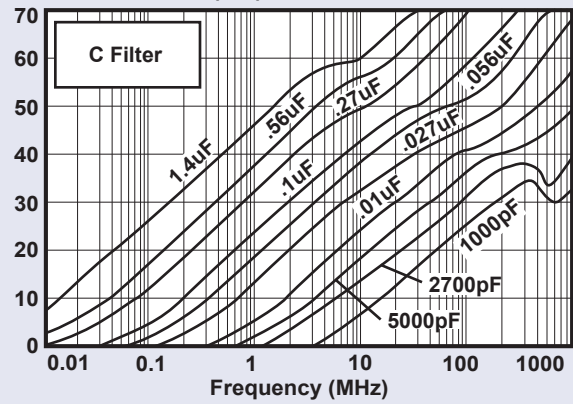

Transfer Impedance Graph

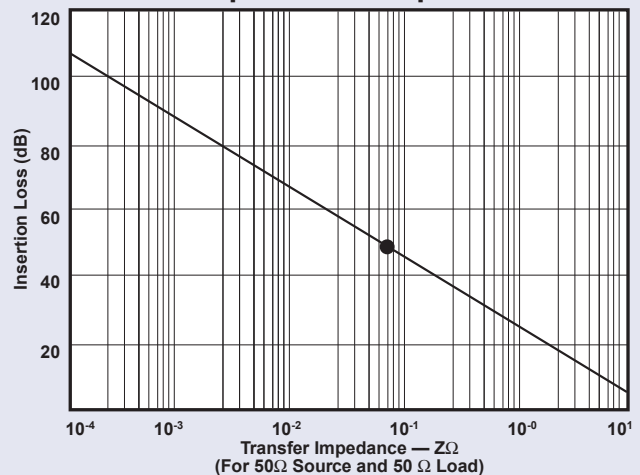

Filter Installation

Threaded Style Filters

| Filter Thread Size | Maximum Mounting Torque | | Mounting Hole Dia. | | Drill Size | |
|--------------------|-------------------------|-------|--------------------|------|------------|-------------|
| | in-lbs | Nm | (in) | (mm) | English | Metric (mm) |
| 4-40 | 1.5 | 0.170 | 0.120 | 3.05 | # 31 | 3.10 |
| 6-40 | 3 | 0.339 | 0.147 | 3.73 | # 26 | 3.75 |
| 6-32 | 3 | 0.339 | 0.147 | 3.73 | # 26 | 3.75 |
| 8-32 | 4 | 0.452 | 0.173 | 4.39 | # 17 | 4.40 |
| 10-32 | 4 | 0.452 | 0.190 | 4.83 | # 8 | 5.10 |
| 12-28 | 6 | 0.678 | 0.228 | 5.79 | # 1 | 5.80 |
| 12-32 | 6 | 0.678 | 0.228 | 5.79 | # 1 | 5.80 |
| 1/4-28 * | 7 | 0.791 | 0.261 | 6.63 | # G | 6.70 |
| 5/16-24 * | 7 | 0.791 | 0.323 | 8.20 | # P | 8.25 |
| 5/16-32 | 7 | 0.791 | 0.323 | 8.20 | # P | 8.25 |
| 3/8-32 | 9 | 1.017 | 0.386 | 9.80 | # W | 9.90 |

Note: For 5/8-24 and 7/16-28 please refer to the specific instruction noted on part drawings or see page LP22 of the catalog.

- Exceeding recommended mounting torque may result in damage to the capacitor within the filter due to possible twisting or elongation of the case.
- For product without hex surfaces do not hold the filter with pliers or other gripping tools. Pressure exerted on the filter case may crack the ceramic capacitor element.
- Proper use of filters requires that the filter case be adequately grounded to form an effective path for the interference.

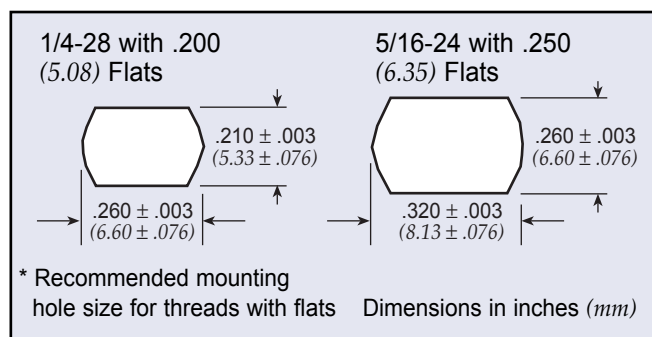

Solder-in Style Filters

- A controlled temperature profile not exceeding 6°F (3°C) per second is recommended when soldering filters.
- When soldering to terminals of a filter, a heat sink should always be used adjacent to the body of the filter.
- 60-40 solder is recommended for installation of the filter into the chassis as well as soldering to the terminals. If a filter style without an eyelet is being soldered into a chassis, iron processes should be avoided and the recommended solder alloy is 60-38-2.
- Installation hole size for a solder-in filter should be 0.003-0.005" over the maximum tolerance of the minor diameter of the mounting portion of the eyelet with a ±0.002" tolerance.
- Machine/oven soldering 385-415°F (195-210°C) using a dwell and cycle time fast enough to reflow the solder and ramped to maintain less than 6°F/sec rate of change.

- For iron soldering to filter body, preheat components at 250-300°F (120-150°C), solder iron is recommended to be set at 500-550°F (260-290°C). The dwell on the solder joint should be less than 5 seconds. The time is dependent on the heat sinking provided by the chassis so a longer preheat may be required.

Soldering to Filter Terminals

- Use a temperature controlled soldering iron with tip temperature of 525 ± 10°F (275 ± 5°C).
- Use an SN 63 RMA flux core solder.
- Make mechanical wire connection.
- Use heat sink next to filter body where possible.
- Clean soldering iron tip.
- Clip end of solder (remove 0.5") to expose flux for soldering.
- Apply soldering iron to wire/flag junction at wetted solder tip region of iron (Wetted Bridge Method). Immediately apply solder. Dwell time for soldering iron tip on product should be 3-5 seconds maximum.

EMI/RFI Filter and Capacitor Performance Testing

The resin sealed and hermetically sealed filters shown in this section have been designed to meet the requirements of this test plan as applicable. Group I tests are typically performed on most product. Groups II, III and IV tests are performed per specification requirements.

The information shown can be used as a basis for filter specifications. (Contact factory for additional details if necessary.)

| Test Group | Order of Test | Examination or Test | Test Method | Post Test Requirements |
|------------|---------------|--|---|--|
| I | *1 | Visual and Mechanical Examination | | In accordance with applicable requirements. |
| | *2 | Materials, Designs, Construction and Workmanship | | |
| | *3 | Physical Dimensions and Marking | | |
| | *4 | Seal | Method 112 [†] , Condition A | No leaks. Not applicable to resin sealed or solder-in products. |
| | *5 | Capacitance | Method 305 [†] , 1KHz. 2.5 VRMS Max. 25°C | Within specified tolerance. |
| | *6 | Dielectric Withstanding Voltage | Method 301 [†] , 2.5 times, DCWV, 5 seconds, 50 Ma max. charging current | No evidence of damage or breakdown. |
| | *7 | Insulation Resistance | Method 302 [†] at DCWV, at 2 minutes 50 ma charging current | Greater than 1000 megohms or 100 ohm farads, whichever is less. |
| | *8 | Voltage Drop | MIL-F-15733, Paragraph 4.6.8 | Per applicable requirements. |
| | *9 | Insertion Loss | MIL-STD-220, 3pc, sample only | Per applicable requirements. |
| II | 1 | Temperature Rise | MIL-F-15733, Paragraph 4.6.4 | Per applicable requirements. |
| | 2 | Overload | MIL-F-15733, Paragraph 4.6.10 | Per applicable requirements. |
| | 3 | Barometric Pressure | Method 105 [†] , Test Condition B hi-pot, (per method 301 [†]) at 1.25 times DCWV | No evidence of damage or breakdown. |
| | 4 | Shock | Method 213 [†] , Test Condition I | No mechanical damage, Insulation resistance greater than 500 ohm farads, whichever is less. |
| | 5 | Vibration | Method 204 [†] , Test Condition B for Glass Seal, Condition D for Resin | No mechanical damage, Insulation resistance greater than 500 megohms or 50 ohm farads, whichever is less. |
| | 6 | Moisture Resistance | Method 106 [†] | Insulation resistance greater than 500 megohms or 50 ohm farads whichever is less. |
| III | 1 | Terminal Strength | Method 211 [†] , Test Condition A, 5 lbs. | No evidence of loosening or rupturing of terminal. |
| | 2 | Resistance to Soldering Heat | Method 210 [†] , Test Condition B, Depth of immersion 1/16 plus or minus 1/32 | Insulation resistance greater than 500 megohms or 50 ohm farads whichever is less. |
| | 3 | Thermal Shock | Method 107 [†] Test Condition A -55°C to +125°C | Insulation resistance greater than 500 megohms or 50 ohm farads whichever is less. |
| | 4 | Immersion Cycling | Method 104 [†] Test Condition A | Insulation resistance greater than 500 megohms or 50 ohm farads whichever is less. |
| IV | 1 | Solderability (5pcs only) | Method 208 [†] | Per applicable requirements. |
| | 2 | Life | Method 108 [†] , Test Condition D with 125% rated voltage at maximum operating temperature | Filters shall meet all initial requirements except insulation resistance shall not be less than 50% of initial guaranteed value. |

* Acceptance tests typically performed on most products.

† Methods are from MIL-STD-202



EMI/RFI Filter and Capacitor Performance Testing

Reliability Levels

Class B

Class B is outlined in MIL-F-28861 and is prescribed for most military/aerospace requirements. It is more stringent than MIL-F-15733 requiring 100% screening that includes thermal shock, voltage conditioning and x-ray.

Periodic Group B testing is performed on units selected at random from production lots.

Class B Test Sequence Summary

| Inspection | Class B |
|---|---------|
| Group I | |
| AC voltage drop (when applicable) | X |
| Voltage and temperature limits of capacitance | X |
| Insertion loss (at temperature) | X |
| Barometric pressure (reduced) | X |
| Temperature rise | X |
| Current overload | X |
| Terminal strength | X |
| Thermal shock and immersion | X |
| Group II | |
| Subgroup 1 | |
| Life | X |
| Subgroup 2 | |
| Resistance to soldering heat | X |
| Salt spray (corrosion) | X |
| Radiographic inspection | X |
| Subgroup 3 | |
| Resistance to solvents | X |
| Group III | |
| Shock (specified pulse) | X |
| Vibration (high frequency) | X |
| Moisture resistance | X |
| Seal (when applicable) | X |
| Radiographic inspection | X |

“R” level testing

“R” level screening is performed by Spectrum Control’s Hi-Rel Laboratory as detailed below. Customers requiring special tests may order to their own specifications or simply order to level R and then note additions or deviations.

“R” level test sequence

(100% testing unless otherwise specified)

- Thermal Shock: 5 cycles from -55°C to +125°C in accordance with MIL-STD-202, Method 107D, Condition A.
- Burn-in: 100 hours at 1.4x rated DC voltage, 125°C.
- Seal Test: MIL-STD-202, Method 112, Test Condition A. Hermetic seal parts only.
- Capacitance and Dissipation Factor: MIL-STD-202, Method 305, frequency 1kHz.
- Dielectric Withstanding Voltage: 2.5 times the rated DC voltage for 5 ± 1 second at 25°C, with 50 mA maximum charging current.
- Insulation Resistance: MIL-STD-202, Method 302, 125°C at rated DC voltage and room temperature (25°C). The 125°C requirement shall be 10% of the specified catalog IR at 25°C.
- DC Resistance: MIL-STD-202, Method 303.
- Insertion Loss Test — Sample per MIL-F-15733. At full rated load in accordance with MIL-STD-220. The minimum insertion loss shall be defined in the filter catalog.
- Visual and Mechanical: in accordance with MIL-F-15733.
- Marking: All filters which have successfully completed the test sequence shall be marked with an “R” in the second part of the number. For example, a standard SCI-2130-004 becomes SCI-R2130-004 and 9051-100-0000 becomes 9051-R100-0000, and 51-719-011 becomes 51-R719-011 after completion of the Hi-Rel Level “R” Test Sequence.

Military Cross Reference Qualified Components

MIL-F-15733

| Military Designation MIL-F-15733 | API Part Number |
|-------------------------------------|-----------------|
| /23-0001 | 51-390-001 |
| /23-0002 | 51-390-002 |
| /23-0003 | 51-390-003 |
| /23-0004 | 51-390-004 |
| /23-0005 | 51-390-301 |
| /23-0006 | 51-390-302 |
| /23-0007 | 51-390-005 |
| /23-0008 | 51-390-006 |
| /23-0009 | 51-390-007 |
| /23-0010 | 51-390-008 |
| /23-0011 | 51-390-303 |
| /23-0012 | 51-390-304 |
| /23-0013 | 51-390-009 |
| /23-0014 | 51-390-010 |
| /23-0015 | 51-390-011 |
| /23-0016 | 51-390-012 |
| /23-0017 | 51-390-305 |
| /23-0018 | 51-390-306 |
| /23-0019 | 51-390-013 |
| /23-0020 | 51-390-014 |
| /23-0021 | 51-390-015 |
| /23-0022 | 51-390-016 |
| /23-0023 | 51-390-307 |
| /23-0024 | 51-390-308 |
| /23-0025 | 51-390-017 |
| /23-0026 | 51-390-018 |
| /23-0027 | 51-390-019 |
| /23-0028 | 51-390-020 |
| /23-0029 | 51-390-309 |
| /23-0030 | 51-390-310 |
| /23-0031 | 51-390-021 |
| /23-0032 | 51-390-022 |
| /23-0033 | 51-390-023 |
| /23-0034 | 51-390-024 |
| /23-0035 | 51-390-311 |
| /23-0036 | 51-390-312 |
| /23-0037 | 51-390-025 |
| /23-0038 | 51-390-026 |
| /23-0039 | 51-390-027 |
| /23-0040 | 51-390-028 |
| /23-0041 | 51-390-313 |
| /23-0042 | 51-390-314 |
| /23-0043 | 51-390-029 |
| /23-0044 | 51-390-030 |
| /23-0045 | 51-390-031 |
| /23-0046 | 51-390-032 |
| /23-0047 | 51-390-315 |
| /23-0049 | 51-390-033 |
| /23-0050 | 51-390-034 |
| /23-0051 | 51-390-035 |
| /23-0052 | 51-390-036 |
| /23-0053 | 51-390-317 |
| /23-0054 | 51-390-318 |
| /23-0055 | 51-390-037 |
| /23-0056 | 51-390-038 |
| /23-0057 | 51-390-039 |
| /23-0058 | 51-390-040 |

| Military Designation MIL-F-15733 | API Part Number |
|-------------------------------------|-----------------|
| /23-0059 | 51-390-319 |
| /23-0060 | 51-390-320 |
| /24-0001 | 51-353-064 |
| /24-0002 | 51-353-065 |
| /24-0003 | 51-444-049 |
| /24-0004 | 51-444-050 |
| /24-0005 | 51-353-066 |
| /24-0006 | 51-353-067 |
| /24-0007 | 51-444-051 |
| /24-0008 | 51-444-060 |
| /24-0009 | 51-353-068 |
| /24-0010 | 51-353-069 |
| /24-0011 | 51-353-070 |
| /24-0012 | 51-353-071 |
| /24-0013 | 51-353-072 |
| /24-0014 | 51-353-073 |
| /24-0015 | 51-353-074 |
| /24-0016 | 51-353-075 |
| /24-0017 | 51-444-052 |
| /24-0018 | 51-444-053 |
| /24-0019 | 51-444-054 |
| /24-0020 | 51-444-055 |
| /24-0021 | 51-444-056 |
| /24-0022 | 51-444-057 |
| /24-0023 | 51-444-058 |
| /24-0024 | 51-444-059 |
| /25-0001 | 51-353-052 |
| /25-0002 | 51-311-308 |
| /25-0003 | 51-353-053 |
| /25-0004 | 51-311-309 |
| /25-0005 | 51-353-054 |
| /25-0006 | 51-311-310 |
| /25-0007 | 51-382-603 |
| /25-0008 | 51-353-055 |
| /25-0009 | 51-353-056 |
| /25-0010 | 51-311-311 |
| /25-0011 | 51-353-057 |
| /25-0012 | 51-382-604 |
| /25-0013 | 51-444-037 |
| /25-0014 | 51-311-354 |
| /25-0015 | 51-444-038 |
| /25-0016 | 51-311-355 |
| /25-0017 | 51-444-039 |
| /25-0018 | 51-311-356 |
| /25-0019 | 51-382-608 |
| /25-0020 | 51-444-040 |
| /25-0021 | 51-444-041 |
| /25-0022 | 51-311-357 |
| /25-0023 | 51-444-042 |
| /25-0024 | 51-382-609 |
| /26-0001 | 51-353-076 |
| /26-0002 | 51-353-336 |
| /26-0003 | 51-353-077 |
| /26-0004 | 51-353-078 |
| /26-0005 | 51-311-312 |
| /26-0006 | 51-353-079 |
| /26-0007 | 51-353-080 |
| /26-0008 | 51-351-603 |

| Military Designation MIL-F-15733 | API Part Number |
|-------------------------------------|---------------------------|
| /26-0009 | 51-311-313 |
| /26-0010 | 51-353-081 |
| /26-0011 | 51-311-314 |
| /26-0012 | 51-351-604 |
| /26-0013 | 51-444-043 |
| /26-0014 | 51-353-424 |
| /26-0015 | 51-444-044 |
| /26-0016 | 51-444-045 |
| /26-0017 | 51-311-358 |
| /26-0018 | 51-444-046 |
| /26-0019 | 51-444-047 |
| /26-0020 | 51-351-625 |
| /26-0021 | 51-311-359 |
| /26-0022 | 51-444-048 |
| /26-0023 | 51-311-360 |
| /26-0024 | 51-351-626 |
| /27-0001 | 51-320-013 |
| /27-0002 | 51-320-014 |
| /27-0003 | 51-323-313 |
| /27-0004 | 51-321-312 |
| /27-0005 | 51-320-015 |
| /27-0006 | 51-320-016 |
| /27-0007 | 51-323-314 |
| /27-0008 | 51-320-017 |
| /27-0009 | 51-320-018 |
| /27-0010 | 51-321-313 |
| /27-0011 | 51-323-003 |
| /27-0012 | 51-323-004 |
| /27-0013 | 51-321-314 |
| /27-0014 | 51-322-009 |
| /27-0015 | 51-322-010 |
| /27-0016 | 51-321-606 |
| /27-0017 | 51-321-607 |
| /27-0018 | 51-321-608 |
| /27-0019 | 51-320-019 |
| /27-0020 | 51-320-020 |
| /27-0021 | 51-323-315 |
| /27-0022 | 51-321-315 |
| /27-0023 | 51-321-609 |
| /27-0026 | 54-310-040 |
| /28-0001 | 51-712-014 |
| /28-0002 | 51-712-028 |
| /28-0003 | Superseded by /61-0014 |
| /28-0004 | 51-712-060 |
| /33-0001 | 51-707-006 |
| /33-0002 | 51-707-007 |
| /34-0001 | 51-322-016 |
| /34-0002 | 51-322-017 |
| /34-0003 | 51-311-327 |
| /34-0004 | 51-321-328 |
| /34-0005 | 51-321-329 |
| /34-0006 | 51-321-330 |
| /34-0007 | 51-353-207 |
| /34-0008 | 51-353-208 |
| /34-0010 | 51-311-007 |
| /34-0011 | 51-320-058 |
| /34-0013 | 51-320-060 |

Military Cross Reference Qualified Components

MIL-F-15733 (cont'd)

| Military Designation MIL-F-15733 | API Part Number |
|-------------------------------------|-----------------|
| /34-0014 | 51-311-340 |
| /34-0015 | 51-444-005 |
| /34-0016 | 51-444-105 |
| /34-0017 | 51-444-016 |
| /34-0018 | 51-444-106 |
| /34-0020 | 51-320-061 |
| /34-0021 | 51-320-062 |
| /34-0029 | 51-320-063 |
| /34-0030 | 51-444-027 |
| /34-0031 | 51-321-391 |
| /34-0035 | 54-370-030 |
| /34-0036 | 54-370-033 |
| /34-0037 | 54-310-039 |
| /38-0001 | 51-343-018 |
| /38-0002 | 51-343-028 |
| /38-0003 | 51-353-422 |
| /38-0004 | 51-359-021 |
| /38-0005 | 51-359-024 |
| /38-0006 | 51-343-034 |
| /38-0008 | 51-359-050 |
| /39-0001 | 51-353-148 |
| /39-0002 | 51-353-149 |
| /39-0003 | 51-353-150 |
| /39-0004 | 51-353-151 |
| /39-0005 | 51-353-152 |
| /39-0006 | 51-353-153 |
| /39-0007 | 51-353-154 |
| /39-0008 | 51-353-155 |
| /39-0009 | 51-353-156 |
| /39-0010 | 51-353-157 |
| /39-0011 | 51-353-344 |
| /39-0012 | 51-353-345 |
| /39-0013 | 51-353-223 |
| /39-0014 | 51-353-287 |
| /39-0015 | 51-353-418 |
| /39-0016 | 51-311-346 |
| /39-0017 | 51-311-347 |
| /39-0018 | 51-311-348 |
| /40-0001 | 51-704-002 |
| /43-0001 | 51-719-023 |
| /43-0002 | 51-712-055 |
| /44-0001 | 51-744-003 |
| /44-0002 | 51-762-005 |
| /44-0003 | 51-762-006 |
| /46-0001 | 51-709-004 |
| /48-0001 | 51-385-038 |
| /48-0002 | 51-385-040 |
| /48-0003 | 51-385-049 |
| /48-0005 | 51-385-050 |
| /49-0001 | 51-359-053 |
| /49-0003 | 51-359-034 |
| /49-0004 | 51-359-035 |
| /49-0006 | 51-359-044 |
| /49-0007 | 51-359-055 |
| /49-0008 | 54-370-032 |
| /49-0010 | 54-370-034 |
| /51-0001 | 51-703-007 |
| /51-0002 | 51-750-313 |

MIL-F-28861

| Military Designation MIL-F-28861 | API Part Number |
|-------------------------------------|-----------------|
| /1-001 | 51-359-081 |
| /1-002 | 54-367-049 |
| /1-003 | 51-359-082 |
| /1-004 | 54-367-050 |
| /1-005 | 51-359-083 |
| /1-006 | 54-367-051 |
| /1-007 | 51-359-084 |
| /1-008 | 54-367-052 |
| /1-009 | 51-359-085 |
| /1-010 | 54-367-053 |
| /1-011 | 51-359-086 |
| /1-012 | 54-367-054 |
| /1-013 | 51-359-087 |
| /1-014 | 54-367-055 |
| /1-015 | 51-359-088 |
| /1-016 | 54-367-056 |
| /1-017 | 51-359-089 |
| /1-018 | 54-367-057 |
| /1-019 | 51-359-090 |
| /1-020 | 54-367-058 |
| /1-021 | 51-359-122 |
| /1-022 | 54-367-085 |
| /1-023 | 51-359-123 |
| /1-024 | 54-367-086 |
| /1-025 | 51-359-124 |
| /1-026 | 54-367-087 |
| /1-031 | 51-359-125 |
| /1-032 | 54-367-088 |
| /1-033 | 51-359-126 |
| /1-034 | 54-367-089 |
| /1-035 | 51-359-127 |
| /1-036 | 54-367-090 |
| /2-001 | 51-311-010 |
| /2-002 | 51-311-011 |
| /2-003 | 51-311-365 |
| /2-004 | 51-311-012 |
| /2-005 | 51-311-013 |
| /2-006 | 51-311-366 |
| /2-007 | 51-311-014 |
| /2-008 | 51-311-015 |
| /2-009 | 51-311-367 |
| /2-010 | 51-311-016 |
| /2-011 | 51-311-017 |
| /2-012 | 51-311-368 |
| /2-013 | 51-311-018 |
| /2-014 | 51-311-019 |
| /2-015 | 51-311-369 |
| /2-016 | 51-311-020 |
| /2-017 | 51-311-021 |
| /2-018 | 51-311-370 |
| /2-019 | 51-311-022 |
| /2-020 | 51-311-023 |
| /2-021 | 51-311-371 |
| /2-022 | 51-311-024 |
| /2-023 | 51-311-025 |
| /2-024 | 51-311-372 |
| /3-001 | 51-390-044 |
| /3-002 | 51-390-045 |

Military Cross Reference Qualified Components

MIL-F-28861 (cont'd)

| Military Designation MIL-F-28861 | API Part Number |
|-------------------------------------|-----------------|
| /3-003 | 51-390-321 |
| /3-004 | 51-390-046 |
| /3-005 | 51-390-047 |
| /3-006 | 51-390-322 |
| /3-007 | 51-390-048 |
| /3-008 | 51-390-049 |
| /3-009 | 51-390-323 |
| /3-010 | 51-390-050 |
| /3-011 | 51-390-051 |
| /3-012 | 51-390-324 |
| /3-013 | 51-390-052 |
| /3-014 | 51-390-053 |
| /3-015 | 51-390-325 |
| /3-016 | 51-390-054 |
| /3-017 | 51-390-055 |
| /3-018 | 51-390-326 |
| /3-019 | 51-390-056 |
| /3-020 | 51-390-057 |
| /3-021 | 51-390-327 |
| /3-022 | 51-390-058 |
| /3-023 | 51-390-059 |
| /3-024 | 51-390-328 |
| /3-025 | 51-390-060 |
| /3-026 | 51-390-061 |
| /3-027 | 51-390-329 |
| /3-028 | 51-390-062 |
| /3-029 | 51-390-063 |
| /3-030 | 51-390-330 |
| /3-031 | 51-390-064 |
| /3-032 | 51-390-065 |
| /3-033 | 51-390-331 |
| /3-034 | 51-390-066 |
| /3-035 | 51-390-067 |
| /3-036 | 51-390-332 |
| /5-001 | 51-311-026 |
| /5-002 | 51-311-027 |
| /5-003 | 51-311-374 |
| /5-004 | 51-311-028 |
| /5-005 | 51-311-029 |
| /5-006 | 51-311-375 |
| /5-007 | 51-311-030 |
| /5-008 | 51-311-031 |
| /5-009 | 51-311-376 |
| /5-010 | 51-311-032 |
| /5-011 | 51-311-033 |
| /5-012 | 51-311-377 |
| /5-013 | 51-311-034 |
| /5-014 | 51-311-035 |
| /5-015 | 51-311-378 |
| /5-016 | 51-311-036 |
| /5-017 | 51-311-037 |
| /5-018 | 51-311-379 |
| /5-019 | 51-311-038 |
| /5-020 | 51-311-039 |
| /5-021 | 51-311-380 |
| /5-022 | 51-311-040 |
| /5-023 | 51-311-041 |
| /5-024 | 51-311-381 |

DSCC 84084 Product

| DSCC Designation | API Part Number |
|------------------|-----------------|
| 84084-001 | 54-310-042 |
| 84084-004 | 51-320-162 |
| 84084-005 | 51-320-163 |
| 84084-006 | 51-320-164 |
| 84084-007 | 51-320-165 |
| 84084-008 | 51-320-166 |
| 84084-009 | 51-320-167 |
| 84084-010 | 51-320-168 |
| 84084-011 | 51-320-169 |
| 84084-013 | 51-321-398 |
| 84084-014 | 51-321-399 |
| 84084-015 | 51-321-400 |
| 84084-016 | 51-321-401 |

MIL-C-11015

| /32 CK# | API Part Number |
|------------|-----------------|
| CK99BW502M | SCI-9900-502AP |
| CK99BW272M | SCI-9910-272AQ |
| CK99BW101M | SCI-9920-101T |
| CK99BW501M | SCI-9920-501K |
| CK99BW122M | SCI-9920-122J |

API Technologies/AMP Part Number Cross Reference

| AMP Part Number | API Part Number |
|-----------------|-----------------|
| 1124033-1 | 56-407-001 |
| 1124034-1 | 56-403-001 |
| 1124082-1 | 56-614-001 |
| 1124174-1 | 56-413-001 |
| 1124175-1 | 56-423-001 |
| 1-842900-3 | 56-702-001-LI |
| 1-842900-0 | 56-702-005-LI |
| 1-842900-1 | 56-702-008-LI |
| 1-842900-2 | 56-702-008-LI |
| 1-842900-4 | 56-702-XXX-LI** |
| 1-842901-3 | 56-712-001-LI |
| 1-842901-0 | 56-712-005-LI |
| 1-842901-1 | 56-712-008-LI |
| 1-842901-2 | 56-712-008-LI |
| 1-842901-4 | 56-712-XXX-LI** |
| 1-842902-3 | 56-722-001-LI |
| 1-842902-0 | 56-722-005-LI |
| 1-842902-1 | 56-722-009-LI |
| 1-842902-2 | 56-722-009-LI |
| 1-842902-4 | 56-722-XXX-LI** |
| 1-842903-3 | 56-732-001-LI |
| 1-842903-0 | 56-732-005-LI |
| 1-842903-1 | 56-732-007-LI |
| 1-842903-2 | 56-732-007-LI |
| 1-842903-4 | 56-732-XXX-LI** |
| 1-842904-3 | 56-742-001-LI |
| 1-842904-0 | 56-742-005-LI |
| 1-842904-1 | 56-742-007-LI |
| 1-842904-2 | 56-742-007-LI |
| 1-842904-4 | 56-742-XXX-LI** |
| 1-842905-3 | 56-704-001-LI |
| 1-842905-0 | 56-704-005-LI |
| 1-842905-1 | 56-704-008-LI |
| 1-842905-2 | 56-704-008-LI |
| 1-842905-7 | 56-704-XXX** |
| 1-842905-4 | 56-704-XXX-LI** |
| 1-842906-3 | 56-714-001-LI |
| 1-842906-0 | 56-714-005-LI |
| 1-842906-1 | 56-714-007-LI |
| 1-842906-2 | 56-714-007-LI |
| 1-842906-4 | 56-714-XXX-LI** |
| 1-842907-3 | 56-724-001-LI |
| 1-842907-0 | 56-724-005-LI |
| 1-842907-1 | 56-724-009-LI |
| 1-842907-2 | 56-724-009-LI |
| 1-842907-4 | 56-724-XXX-LI** |
| 1-842908-3 | 56-734-001-LI |
| 1-842908-0 | 56-734-005-LI |
| 1-842908-1 | 56-734-007-LI |
| 1-842908-2 | 56-734-007-LI |
| 1-842908-4 | 56-734-XXX-LI** |
| 1-842909-3 | 56-744-001-LI |
| 1-842909-0 | 56-744-005-LI |
| 1-842909-1 | 56-744-007-LI |
| 1-842909-2 | 56-744-007-LI |
| 1-842909-4 | 56-744-XXX-LI** |
| 1-842910-3 | 56-701-001-LI |
| 1-842910-0 | 56-701-005-LI |
| 1-842910-1 | 56-701-029-LI |
| 1-842910-2 | 56-701-029-LI |
| 1-842910-4 | 56-701-XXX-LI** |

| AMP Part Number | API Part Number |
|-----------------|-----------------|
| 1-842911-3 | 56-711-001-LI |
| 1-842911-0 | 56-711-005-LI |
| 1-842911-1 | 56-711-029-LI |
| 1-842911-2 | 56-711-029-LI |
| 1-842911-4 | 56-711-XXX-LI** |
| 1-842912-3 | 56-721-001-LI |
| 1-842912-0 | 56-721-005-LI |
| 1-842912-1 | 56-721-034-LI |
| 1-842912-2 | 56-721-034-LI |
| 1-842912-4 | 56-721-XXX-LI** |
| 1-842913-3 | 56-731-001-LI |
| 1-842913-0 | 56-731-005-LI |
| 1-842913-1 | 56-731-029-LI |
| 1-842913-2 | 56-731-029-LI |
| 1-842913-4 | 56-731-XXX-LI** |
| 1-842914-3 | 56-741-001-LI |
| 1-842914-0 | 56-741-005-LI |
| 1-842914-1 | 56-741-028-LI |
| 1-842914-2 | 56-741-028-LI |
| 1-842914-4 | 56-741-XXX-LI** |
| 1-842915-3 | 56-703-001-LI |
| 1-842915-0 | 56-703-005-LI |
| 1-842915-1 | 56-703-023-LI |
| 1-842915-2 | 56-703-023-LI |
| 1-842915-4 | 56-703-XXX-LI** |
| 1-842916-3 | 56-713-001-LI |
| 1-842916-0 | 56-713-005-LI |
| 1-842916-1 | 56-713-022-LI |
| 1-842916-2 | 56-713-022-LI |
| 1-842916-4 | 56-713-XXX-LI** |
| 1-842917-3 | 56-723-001-LI |
| 1-842917-0 | 56-723-005-LI |
| 1-842917-1 | 56-723-024-LI |
| 1-842917-2 | 56-723-024-LI |
| 1-842917-4 | 56-723-XXX-LI** |
| 1-842918-3 | 56-733-001-LI |
| 1-842918-0 | 56-733-005-LI |
| 1-842918-1 | 56-733-022-LI |
| 1-842918-2 | 56-733-022-LI |
| 1-842918-4 | 56-733-XXX-LI** |
| 1-842919-3 | 56-743-001-LI |
| 1-842919-0 | 56-743-005-LI |
| 1-842919-1 | 56-743-022-LI |
| 1-842919-2 | 56-743-022-LI |
| 1-842919-4 | 56-743-XXX-LI** |
| 1-842920-3 | 56-701-011-LI |
| 1-842920-0 | 56-701-015-LI |
| 1-842920-1 | 56-701-041-LI |
| 1-842920-2 | 56-701-041-LI |
| 1-842920-4 | 56-701-XXX-LI** |
| 1-842921-3 | 56-711-011-LI |
| 1-842921-0 | 56-711-015-LI |
| 1-842921-1 | 56-711-041-LI |
| 1-842921-2 | 56-711-041-LI |
| 1-842921-4 | 56-711-XXX-LI** |
| 1-842922-3 | 56-721-011-LI |
| 1-842922-0 | 56-721-015-LI |
| 1-842922-1 | 56-721-046-LI |
| 1-842922-2 | 56-721-046-LI |
| 1-842922-4 | 56-721-XXX-LI** |
| 1-842923-3 | 56-731-011-LI |

| AMP Part Number | API Part Number |
|-----------------|-----------------|
| 1-842923-0 | 56-731-015-LI |
| 1-842923-1 | 56-731-041-LI |
| 1-842923-2 | 56-731-041-LI |
| 1-842923-4 | 56-731-XXX-LI** |
| 1-842924-3 | 56-741-011-LI |
| 1-842924-0 | 56-741-015-LI |
| 1-842924-1 | 56-741-040-LI |
| 1-842924-2 | 56-741-040-LI |
| 1-842924-4 | 56-741-XXX-LI** |
| 1-842925-3 | 56-706-001-LI |
| 1-842925-0 | 56-706-005-LI |
| 1-842925-1 | 56-706-007-LI |
| 1-842925-2 | 56-706-007-LI |
| 1-842925-8 | 56-706-XXX** |
| 1-842925-4 | 56-706-XXX-LI** |
| 1-842926-3 | 56-716-001-LI |
| 1-842926-0 | 56-716-005-LI |
| 1-842926-1 | 56-716-007-LI |
| 1-842926-2 | 56-716-007-LI |
| 1-842926-4 | 56-716-XXX-LI** |
| 1-842927-3 | 56-726-001-LI |
| 1-842927-0 | 56-726-005-LI |
| 1-842927-1 | 56-726-007-LI |
| 1-842927-2 | 56-726-007-LI |
| 1-842927-4 | 56-726-XXX-LI** |
| 1-842928-3 | 56-736-001-LI |
| 1-842928-0 | 56-736-005-LI |
| 1-842928-1 | 56-736-007-LI |
| 1-842928-2 | 56-736-007-LI |
| 1-842928-6 | 56-736-XXX** |
| 1-842928-7 | 56-736-XXX** |
| 1-842928-4 | 56-736-XXX-LI** |
| 1-842929-3 | 56-746-001-LI |
| 1-842929-0 | 56-746-005-LI |
| 1-842929-1 | 56-746-007-LI |
| 1-842929-2 | 56-746-007-LI |
| 1-842929-4 | 56-746-XXX-LI** |
| 1-842930-3 | 56-705-001-LI |
| 1-842930-0 | 56-705-005-LI |
| 1-842930-1 | 56-705-009-LI |
| 1-842930-2 | 56-705-009-LI |
| 1-842930-4 | 56-705-XXX-LI** |
| 1-842931-3 | 56-715-001-LI |
| 1-842931-0 | 56-715-005-LI |
| 1-842931-1 | 56-715-008-LI |
| 1-842931-2 | 56-715-008-LI |
| 1-842931-4 | 56-715-XXX-LI** |
| 1-842932-3 | 56-725-001-LI |
| 1-842932-0 | 56-725-005-LI |
| 1-842932-1 | 56-725-020-LI |
| 1-842932-2 | 56-725-020-LI |
| 1-842932-4 | 56-725-XXX-LI** |
| 1-842933-3 | 56-735-001-LI |
| 1-842933-0 | 56-735-005-LI |
| 1-842933-1 | 56-735-009-LI |
| 1-842933-2 | 56-735-009-LI |
| 1-842933-4 | 56-735-XXX-LI** |
| 1-842934-3 | 56-745-001-LI |
| 1-842934-0 | 56-745-005-LI |
| 1-842934-1 | 56-745-007-LI |
| 1-842934-2 | 56-745-007-LI |

* There may be mechanical and/or electrical differences between the Amp and Spectrum part. Please consult factory.

** A standard part number does not currently exist but will be assigned upon ordering.

API Technologies/AMP Part Number Cross Reference

| AMP Part Number | API Part Number |
|-----------------|-----------------|
| 1-842934-4 | 56-745-XXX-LI** |
| 1-93768-0 | 56-701-081-LI |
| 1-93769-0 | 56-711-085-LI |
| 1-93770-0 | 56-721-070-LI |
| 1-93771-0 | 56-731-060-LI |
| 1-93772-0 | 56-706-009-LI |
| 1-93773-0 | 56-716-009-LI |
| 1-93774-0 | 56-726-009-LI |
| 1-93775-0 | 56-736-009-LI |
| 267028-1 | 56-B12-000-K |
| 267100-1 | 56-C31-001 |
| 267116-1 | 56-407-001 |
| 267161-2 | 56-423-001 |
| 267290-1 | 56-724-008-GBL |
| 267292-1 | 56-624-XXX** |
| 267397-1 | 56-413-001 |
| 267533-1 | 56-B22-000-S |
| 267534-1 | 56-B42-000-S |
| 267534-2 | 56-B42-000-K |
| 267809-1 | 56-703-022 |
| 267810-1 | 56-713-021 |
| 267811-1 | 56-723-022 |
| 2-842919-6 | 56-743-003-LI |
| 2-842920-2 | 56-701-042 |
| 2-842927-2 | 56-726-XXX** |
| 3-842917-1 | 56-723-045-LI |
| 3-842917-2 | 56-723-XXX** |
| 3-842917-3 | 56-723-XXX** |
| 842582-3 | 56-701-047 |
| 842582-4 | 56-701-047-LI |
| 842583-3 | 56-711-048 |
| 842583-4 | 56-711-048-LI |
| 842584-3 | 56-721-063 |
| 842584-4 | 56-721-063-LI |
| 842585-3 | 56-731-048 |
| 842585-4 | 56-731-048-LI |
| 842586-3 | 56-703-036 |
| 842586-4 | 56-703-036-LI |
| 842587-3 | 56-713-037 |
| 842587-4 | 56-713-037-LI |
| 842588-3 | 56-723-045 |
| 842588-4 | 56-723-045-LI |
| 842589-3 | 56-733-035 |
| 842589-4 | 56-733-035-LI |
| 842590-3 | 56-702-013 |
| 842590-4 | 56-702-013-LI |
| 842591-3 | 56-712-017 |
| 842591-4 | 56-712-017-LI |
| 842592-3 | 56-722-027 |
| 842592-4 | 56-722-027-LI |
| 842593-3 | 56-732-009 |
| 842593-4 | 56-732-009-LI |
| 842594-3 | 56-704-018 |
| 842594-4 | 56-704-018-LI |
| 842595-3 | 56-714-017 |
| 842595-4 | 56-714-017-LI |
| 842596-3 | 56-724-021 |
| 842596-4 | 56-724-021-LI |
| 842597-3 | 56-734-012 |
| 842597-4 | 56-734-012-LI |

| AMP Part Number | API Part Number |
|-----------------|-----------------|
| 842610-3 | 56-701-086 |
| 842610-4 | 56-701-086-LI |
| 842611-3 | 56-711-088 |
| 842611-4 | 56-711-088-LI |
| 842612-3 | 56-721-111 |
| 842612-4 | 56-721-111-LI |
| 842613-3 | 56-731-076 |
| 842613-4 | 56-731-076-LI |
| 842614-3 | 56-703-047 |
| 842614-4 | 56-703-047-LI |
| 842615-3 | 56-713-045 |
| 842615-4 | 56-713-045-LI |
| 842616-3 | 56-723-069 |
| 842616-4 | 56-723-069-LI |
| 842617-3 | 56-733-046 |
| 842617-4 | 56-733-046-LI |
| 842618-3 | 56-702-033 |
| 842618-4 | 56-702-033-LI |
| 842619-3 | 56-712-039 |
| 842619-4 | 56-712-039-LI |
| 842620-3 | 56-722-060 |
| 842620-4 | 56-722-060-LI |
| 842621-3 | 56-732-023-LI |
| 842621-4 | 56-732-023-LI |
| 842622-3 | 56-704-035 |
| 842622-4 | 56-704-035-LI |
| 842623-3 | 56-714-031 |
| 842623-4 | 56-714-031-LI |
| 842624-3 | 56-724-046 |
| 842624-4 | 56-724-046-LI |
| 842625-3 | 56-734-021 |
| 842625-4 | 56-734-021-LI |
| 842638-3 | 56-701-028 |
| 842638-4 | 56-701-028-LI |
| 842639-3 | 56-711-028 |
| 842639-4 | 56-711-028-LI |
| 842640-3 | 56-721-033 |
| 842640-4 | 56-721-033-LI |
| 842641-3 | 56-731-028 |
| 842641-4 | 56-731-028-LI |
| 842642-3 | 56-703-022 |
| 842642-4 | 56-703-022-LI |
| 842643-3 | 56-713-021 |
| 842643-4 | 56-713-021-LI |
| 842644-3 | 56-723-023 |
| 842644-4 | 56-723-023-LI |
| 842645-3 | 56-733-021 |
| 842645-4 | 56-733-021-LI |
| 842646-3 | 56-702-007 |
| 842646-4 | 56-702-007-LI |
| 842647-3 | 56-712-007 |
| 842647-4 | 56-712-007-LI |
| 842648-3 | 56-722-008 |
| 842648-4 | 56-722-008-LI |
| 842649-3 | 56-732-006 |
| 842649-4 | 56-732-006-LI |
| 842650-3 | 56-704-007 |
| 842650-4 | 56-704-007-LI |
| 842651-3 | 56-714-006 |
| 842651-4 | 56-714-006-LI |

| AMP Part Number | API Part Number |
|-----------------|-----------------|
| 842652-3 | 56-724-008 |
| 842652-4 | 56-724-008-LI |
| 842653-3 | 56-734-006 |
| 842653-4 | 56-734-006-LI |
| 842666-3 | 56-701-002 |
| 842666-4 | 56-701-002-LI |
| 842667-3 | 56-711-002 |
| 842667-4 | 56-711-002-LI |
| 842668-3 | 56-721-002 |
| 842668-4 | 56-721-002-LI |
| 842669-3 | 56-731-002 |
| 842669-4 | 56-731-002-LI |
| 842670-3 | 56-703-002 |
| 842670-4 | 56-703-002-LI |
| 842671-3 | 56-713-002 |
| 842671-4 | 56-713-002-LI |
| 842672-3 | 56-723-002 |
| 842672-4 | 56-723-002-LI |
| 842673-3 | 56-733-002 |
| 842673-4 | 56-733-002-LI |
| 842674-3 | 56-702-002 |
| 842674-4 | 56-702-002-LI |
| 842675-3 | 56-712-002 |
| 842675-4 | 56-712-002-LI |
| 842675-5 | 56-712-002-LIM |
| 842676-3 | 56-722-002 |
| 842676-4 | 56-722-002-LI |
| 842677-3 | 56-732-002 |
| 842677-4 | 56-732-002-LI |
| 842678-3 | 56-704-002 |
| 842678-4 | 56-704-002-LI |
| 842679-3 | 56-714-002 |
| 842679-4 | 56-714-002-LI |
| 842680-3 | 56-724-002 |
| 842680-4 | 56-724-002-LI |
| 842681-3 | 56-734-002 |
| 842681-4 | 56-734-002-LI |
| 842697-3 | 56-705-008 |
| 842697-4 | 56-705-008-LI |
| 842697-5 | 56-705-026-LI |
| 842697-5 | 56-705-XXX** |
| 842698-3 | 56-715-007 |
| 842698-4 | 56-715-007-LI |
| 842699-3 | 56-725-019 |
| 842699-4 | 56-725-019-LI |
| 842699-4 | 56-725-019-LI |
| 842700-3 | 56-735-008 |
| 842700-4 | 56-735-008-LI |
| 842737-3 | 56-705-002 |
| 842737-4 | 56-705-002-LI |
| 842738-3 | 56-705-026 |
| 842738-4 | 56-705-026-LI |
| 842738-5 | 56-705-026-HV |
| 842739-3 | 56-705-049 |
| 842739-4 | 56-705-049-LI |
| 842740-3 | 56-715-002 |
| 842740-4 | 56-715-002-LI |
| 842741-3 | 56-715-015 |
| 842741-4 | 56-715-015-LI |
| 842742-3 | 56-715-040 |

* There may be mechanical and/or electrical differences between the Amp and Spectrum part. Please consult factory.

** A standard part number does not currently exist but will be assigned upon ordering.

API Technologies/AMP Part Number Cross Reference

| AMP Part Number | API Part Number |
|-----------------|-----------------|
| 842742-4 | 56-715-040-LI |
| 842743-3 | 56-725-002 |
| 842743-4 | 56-725-002-LI |
| 842744-3 | 56-725-064 |
| 842744-4 | 56-725-064-LI |
| 842744-5 | 56-725-XXX** |
| 842745-3 | 56-725-073 |
| 842745-4 | 56-725-073-LI |
| 842746-3 | 56-735-002 |
| 842746-4 | 56-735-002-LI |
| 842747-3 | 56-735-025 |
| 842747-4 | 56-735-025-LI |
| 842748-3 | 56-735-034 |
| 842748-4 | 56-735-034-LI |
| 842796-2 | 56-725-064-HV |
| 842797-2 | 56-735-025-HV |
| 842830-3 | 56-706-006 |
| 842900-1 | 56-702-003 |
| 842900-2 | 56-702-009 |
| 842900-3 | 56-702-005 |
| 842900-4 | 56-702-008 |
| 842900-5 | 56-702-008 |
| 842900-6 | 56-702-001 |
| 842900-7 | 56-702-XXX** |
| 842900-8 | 56-702-003-LI |
| 842900-9 | 56-702-009-LI |
| 842901-1 | 56-712-003 |
| 842901-2 | 56-712-009 |
| 842901-3 | 56-712-005 |
| 842901-4 | 56-712-008 |
| 842901-5 | 56-712-008 |
| 842901-6 | 56-712-001 |
| 842901-7 | 56-712-XXX** |
| 842901-8 | 56-712-003-LI |
| 842901-9 | 56-712-009-LI |
| 842902-1 | 56-722-003 |
| 842902-2 | 56-722-010 |
| 842902-3 | 56-722-005 |
| 842902-4 | 56-722-009 |
| 842902-5 | 56-722-009 |
| 842902-6 | 56-722-001 |
| 842902-7 | 56-722-XXX** |
| 842902-8 | 56-722-003-LI |
| 842902-9 | 56-722-010-LI |
| 842903-1 | 56-732-003 |
| 842903-2 | 56-732-008 |
| 842903-3 | 56-732-005 |
| 842903-4 | 56-732-007 |
| 842903-5 | 56-732-007 |
| 842903-6 | 56-732-001 |
| 842903-7 | 56-732-XXX** |
| 842903-8 | 56-732-003-LI |
| 842903-9 | 56-732-008-LI |
| 842904-1 | 56-742-003 |
| 842904-2 | 56-742-008 |
| 842904-3 | 56-742-005 |
| 842904-4 | 56-742-007 |
| 842904-5 | 56-742-007 |
| 842904-6 | 56-742-001 |
| 842904-7 | 56-742-XXX** |

| AMP Part Number | API Part Number |
|-----------------|-----------------|
| 842904-8 | 56-742-003-LI |
| 842904-9 | 56-742-008-LI |
| 842905-1 | 56-704-003 |
| 842905-2 | 56-704-009 |
| 842905-3 | 56-704-005 |
| 842905-4 | 56-704-008 |
| 842905-5 | 56-704-008 |
| 842905-6 | 56-704-001 |
| 842905-7 | 56-704-XXX** |
| 842905-8 | 56-704-003-LI |
| 842905-9 | 56-704-009-LI |
| 842906-1 | 56-714-003 |
| 842906-2 | 56-714-008 |
| 842906-3 | 56-714-005 |
| 842906-4 | 56-714-007 |
| 842906-5 | 56-714-007 |
| 842906-6 | 56-714-001 |
| 842906-7 | 56-714-XXX** |
| 842906-8 | 56-714-003-LI |
| 842906-9 | 56-714-008-LI |
| 842907-1 | 56-724-003 |
| 842907-2 | 56-724-010 |
| 842907-3 | 56-724-005 |
| 842907-4 | 56-724-009 |
| 842907-5 | 56-724-009 |
| 842907-6 | 56-724-001 |
| 842907-7 | 56-724-XXX** |
| 842907-8 | 56-724-003-LI |
| 842907-9 | 56-724-010-LI |
| 842908-1 | 56-734-003 |
| 842908-2 | 56-734-008 |
| 842908-3 | 56-734-005 |
| 842908-4 | 56-734-007 |
| 842908-5 | 56-734-007 |
| 842908-6 | 56-734-001 |
| 842908-7 | 56-734-XXX** |
| 842908-8 | 56-734-003-LI |
| 842908-9 | 56-734-008-LI |
| 842909-1 | 56-744-003 |
| 842909-2 | 56-744-008 |
| 842909-3 | 56-744-005 |
| 842909-4 | 56-744-007 |
| 842909-5 | 56-744-007 |
| 842909-6 | 56-744-001 |
| 842909-7 | 56-744-XXX** |
| 842909-8 | 56-744-003-LI |
| 842909-9 | 56-744-008-LI |
| 842910-1 | 56-701-003 |
| 842910-2 | 56-701-030 |
| 842910-3 | 56-701-005 |
| 842910-4 | 56-701-029 |
| 842910-5 | 56-701-029 |
| 842910-6 | 56-701-001 |
| 842910-7 | 56-701-XXX** |
| 842910-8 | 56-701-003-LI |
| 842910-9 | 56-701-030-LI |
| 842911-1 | 56-711-003 |
| 842911-2 | 56-711-030 |
| 842911-3 | 56-711-005 |
| 842911-4 | 56-711-029 |

| AMP Part Number | API Part Number |
|-----------------|-----------------|
| 842911-5 | 56-711-029 |
| 842911-6 | 56-711-001 |
| 842911-7 | 56-711-XXX** |
| 842911-8 | 56-711-003-LI |
| 842911-9 | 56-711-030-LI |
| 842912-1 | 56-721-003 |
| 842912-2 | 56-721-035 |
| 842912-3 | 56-721-005 |
| 842912-4 | 56-721-034 |
| 842912-5 | 56-721-034 |
| 842912-6 | 56-721-001 |
| 842912-7 | 56-721-XXX** |
| 842912-8 | 56-721-003-LI |
| 842912-9 | 56-721-035-LI |
| 842913-1 | 56-731-003 |
| 842913-2 | 56-731-030 |
| 842913-3 | 56-731-005 |
| 842913-4 | 56-731-029 |
| 842913-5 | 56-731-029 |
| 842913-6 | 56-731-001 |
| 842913-7 | 56-731-XXX** |
| 842913-8 | 56-731-003-LI |
| 842913-9 | 56-731-030-LI |
| 842914-1 | 56-741-003 |
| 842914-2 | 56-741-029 |
| 842914-3 | 56-741-005 |
| 842914-4 | 56-741-028 |
| 842914-5 | 56-741-028 |
| 842914-6 | 56-741-001 |
| 842914-7 | 56-741-XXX** |
| 842914-8 | 56-741-003-LI |
| 842914-9 | 56-741-029-LI |
| 842915-1 | 56-703-003 |
| 842915-2 | 56-703-024 |
| 842915-3 | 56-703-005 |
| 842915-4 | 56-703-023 |
| 842915-5 | 56-703-023 |
| 842915-6 | 56-703-001 |
| 842915-7 | 56-703-XXX** |
| 842915-8 | 56-703-003-LI |
| 842915-9 | 56-703-024-LI |
| 842916-1 | 56-713-003 |
| 842916-2 | 56-713-023 |
| 842916-3 | 56-713-005 |
| 842916-4 | 56-713-022 |
| 842916-5 | 56-713-022 |
| 842916-6 | 56-713-001 |
| 842916-7 | 56-713-XXX** |
| 842916-8 | 56-713-003-LI |
| 842916-9 | 56-713-023-LI |
| 842917-1 | 56-723-003 |
| 842917-2 | 56-723-025 |
| 842917-3 | 56-723-005 |
| 842917-4 | 56-723-024 |
| 842917-5 | 56-723-024 |
| 842917-6 | 56-723-001 |
| 842917-7 | 56-723-XXX** |
| 842917-8 | 56-723-003-LI |
| 842917-9 | 56-723-025-LI |
| 842918-1 | 56-733-003 |

* There may be mechanical and/or electrical differences between the Amp and Spectrum part. Please consult factory.

** A standard part number does not currently exist but will be assigned upon ordering.

API Technologies/AMP Part Number Cross Reference

| AMP Part Number | API Part Number |
|-----------------|-----------------|
| 842918-2 | 56-733-023 |
| 842918-3 | 56-733-005 |
| 842918-4 | 56-733-022 |
| 842918-5 | 56-733-022 |
| 842918-6 | 56-733-001 |
| 842918-7 | 56-733-XXX** |
| 842918-8 | 56-733-003-LI |
| 842918-9 | 56-733-023-LI |
| 842919-1 | 56-743-003 |
| 842919-2 | 56-743-023 |
| 842919-3 | 56-743-005 |
| 842919-4 | 56-743-022 |
| 842919-5 | 56-743-022 |
| 842919-6 | 56-743-001 |
| 842919-7 | 56-743-XXX** |
| 842919-8 | 56-743-003-LI |
| 842919-9 | 56-743-023-LI |
| 842920-1 | 56-701-013 |
| 842920-2 | 56-701-042 |
| 842920-3 | 56-701-015 |
| 842920-4 | 56-701-041 |
| 842920-5 | 56-701-041 |
| 842920-6 | 56-701-011 |
| 842920-7 | 56-701-XXX** |
| 842920-8 | 56-701-013-LI |
| 842920-9 | 56-701-042-LI |
| 842921-1 | 56-711-013 |
| 842921-2 | 56-711-042 |
| 842921-3 | 56-711-015 |
| 842921-4 | 56-711-041 |
| 842921-5 | 56-711-041 |
| 842921-6 | 56-711-011 |
| 842921-7 | 56-711-XXX** |
| 842921-8 | 56-711-013-LI |
| 842921-9 | 56-711-042-LI |
| 842922-1 | 56-721-013 |
| 842922-2 | 56-721-047 |
| 842922-3 | 56-721-015 |
| 842922-4 | 56-721-046 |
| 842922-5 | 56-721-046 |
| 842922-6 | 56-721-011 |
| 842922-7 | 56-721-XXX** |
| 842922-8 | 56-721-013-LI |
| 842922-9 | 56-721-047-LI |
| 842923-1 | 56-731-013 |
| 842923-2 | 56-731-042 |
| 842923-3 | 56-731-015 |
| 842923-4 | 56-731-041 |
| 842923-5 | 56-731-041 |
| 842923-6 | 56-731-011 |
| 842923-7 | 56-731-XXX** |
| 842923-8 | 56-731-013-LI |
| 842923-9 | 56-731-042-LI |
| 842924-1 | 56-741-013 |
| 842924-2 | 56-741-041 |
| 842924-3 | 56-741-015 |
| 842924-4 | 56-741-040 |
| 842924-5 | 56-741-040 |
| 842924-6 | 56-741-011 |
| 842924-7 | 56-741-XXX** |

| AMP Part Number | API Part Number |
|-----------------|-----------------|
| 842924-8 | 56-741-013-LI |
| 842924-9 | 56-741-041-LI |
| 842925-1 | 56-706-003 |
| 842925-2 | 56-706-008 |
| 842925-3 | 56-706-005 |
| 842925-4 | 56-706-007 |
| 842925-5 | 56-706-007 |
| 842925-6 | 56-706-001 |
| 842925-7 | 56-706-XXX** |
| 842925-8 | 56-706-003-LI |
| 842925-9 | 56-706-005-LI |
| 842926-1 | 56-716-003 |
| 842926-2 | 56-716-008 |
| 842926-3 | 56-716-005 |
| 842926-4 | 56-716-007 |
| 842926-5 | 56-716-007 |
| 842926-6 | 56-716-001 |
| 842926-7 | 56-716-XXX** |
| 842926-8 | 56-716-003-LI |
| 842926-9 | 56-716-008-LI |
| 842927-1 | 56-726-003 |
| 842927-2 | 56-726-008 |
| 842927-3 | 56-726-005 |
| 842927-4 | 56-726-007 |
| 842927-5 | 56-726-007 |
| 842927-6 | 56-726-001 |
| 842927-7 | 56-726-XXX** |
| 842927-8 | 56-726-003-LI |
| 842927-9 | 56-726-008-LI |
| 842928-1 | 56-736-003 |
| 842928-2 | 56-736-008 |
| 842928-3 | 56-736-005 |
| 842928-4 | 56-736-007 |
| 842928-5 | 56-736-007 |
| 842928-6 | 56-736-001 |
| 842928-7 | 56-736-XXX** |
| 842928-8 | 56-736-003-LI |
| 842928-9 | 56-736-008-LI |
| 842929-1 | 56-746-003 |
| 842929-2 | 56-746-008 |
| 842929-3 | 56-746-005 |
| 842929-4 | 56-746-007 |
| 842929-5 | 56-746-007 |
| 842929-6 | 56-746-001 |
| 842929-7 | 56-746-XXX** |
| 842929-8 | 56-746-003-LI |
| 842929-9 | 56-746-008-LI |
| 842930-1 | 56-705-003 |
| 842930-2 | 56-705-010 |
| 842930-3 | 56-705-005 |
| 842930-4 | 56-705-009 |
| 842930-5 | 56-705-009 |
| 842930-6 | 56-705-001 |
| 842930-7 | 56-705-XXX** |
| 842930-8 | 56-705-003-LI |
| 842930-9 | 56-705-010-LI |
| 842931-1 | 56-715-003 |
| 842931-2 | 56-715-009 |
| 842931-3 | 56-715-005 |
| 842931-4 | 56-715-008 |

| AMP Part Number | API Part Number |
|-----------------|-----------------|
| 842931-5 | 56-715-008 |
| 842931-6 | 56-715-001 |
| 842931-7 | 56-715-XXX** |
| 842931-8 | 56-715-003-LI |
| 842931-9 | 56-715-009-LI |
| 842932-1 | 56-725-003 |
| 842932-2 | 56-725-021 |
| 842932-3 | 56-725-005 |
| 842932-4 | 56-725-020 |
| 842932-5 | 56-725-020 |
| 842932-6 | 56-725-001 |
| 842932-7 | 56-725-XXX** |
| 842932-8 | 56-725-003-LI |
| 842932-9 | 56-725-021-LI |
| 842933-1 | 56-735-003 |
| 842933-2 | 56-735-010 |
| 842933-3 | 56-735-005 |
| 842933-4 | 56-735-009 |
| 842933-5 | 56-735-009 |
| 842933-6 | 56-735-001 |
| 842933-7 | 56-735-XXX** |
| 842933-8 | 56-735-003-LI |
| 842933-9 | 56-735-010-LI |
| 842934-1 | 56-745-003 |
| 842934-2 | 56-745-008 |
| 842934-3 | 56-745-005 |
| 842934-4 | 56-745-007 |
| 842934-5 | 56-745-007 |
| 842934-6 | 56-745-001 |
| 842934-7 | 56-745-XXX** |
| 842934-8 | 56-745-003-LI |
| 842934-9 | 56-745-008-LI |
| 842938-1 | 56-701-004 |
| 842938-2 | 56-701-004-LI |
| 842939-1 | 56-711-004 |
| 842939-2 | 56-711-004-LI |
| 842940-1 | 56-721-004 |
| 842940-2 | 56-721-004-LI |
| 842941-1 | 56-731-004 |
| 842941-2 | 56-731-004-LI |
| 842942-1 | 56-703-004 |
| 842942-2 | 56-703-004-LI |
| 842943-1 | 56-713-004 |
| 842943-2 | 56-713-004-LI |
| 842944-1 | 56-723-004 |
| 842944-2 | 56-723-004-LI |
| 842945-1 | 56-733-004 |
| 842945-2 | 56-733-004-LI |
| 842946-1 | 56-702-004 |
| 842946-2 | 56-702-004-LI |
| 842947-1 | 56-712-004 |
| 842947-2 | 56-712-004-LI |
| 842948-1 | 56-722-004 |
| 842948-2 | 56-722-004-LI |
| 842949-1 | 56-732-004 |
| 842949-2 | 56-732-004-LI |
| 842950-1 | 56-704-004 |
| 842950-2 | 56-704-004-LI |
| 842951-1 | 56-714-004 |
| 842951-2 | 56-714-004-LI |

* There may be mechanical and/or electrical differences between the Amp and Spectrum part. Please consult factory.

** A standard part number does not currently exist but will be assigned upon ordering.

API Technologies/AMP Part Number Cross Reference

| AMP Part Number | API Part Number |
|-----------------|-----------------|
| 842952-1 | 56-724-004 |
| 842952-2 | 56-724-004-LI |
| 842953-1 | 56-734-004 |
| 842953-2 | 56-734-004-LI |
| 842954-1 | 56-705-004 |
| 842954-2 | 56-705-004-LI |
| 842955-1 | 56-715-004 |
| 842955-2 | 56-715-004-LI |
| 842956-1 | 56-725-004 |
| 842956-2 | 56-725-004-LI |
| 842956-3 | 56-725-004-LI |
| 842957-1 | 56-735-004 |
| 842957-2 | 56-735-004-LI |
| 842957-3 | 56-735-004-LI |
| 859762-1 | 56-726-003 |
| 869202-1 | 56-715-004 |
| 869214-1 | 56-701-003-LIM |
| 869248-1 | 56-711-003-LIM |
| 869408-1 | 56-715-XXX** |
| 869427-2 | 56-414-001-HD |
| 869436-2 | 56-402-001 |
| 869442-2 | 56-422-001 |
| 869454-1 | 56-704-007-LI |
| 869504-1 & 2 | 56-B32-000-S |
| 869505-1 | 56-B52-000-S |
| 869508-1 & 2 | 56-B32-000-K |
| 869509-1 | 56-B52-000-K |
| 869520-2 | 56-404-001 |
| 869521-2 | 56-424-001 |
| 93725-1 | 56-C33-001 |
| 93768-1 | 56-701-014 |
| 93768-2 | 56-701-012 |
| 93768-3 | 56-701-040 |
| 93768-4 | 56-701-087 |
| 93768-5 | 56-701-081 |
| 93768-6 | 56-701-014-LI |
| 93768-7 | 56-701-012-LI |
| 93768-8 | 56-701-040-LI |
| 93768-9 | 56-701-087-LI |
| 93769-1 | 56-711-014 |
| 93769-2 | 56-711-012 |
| 93769-3 | 56-711-040 |
| 93769-4 | 56-711-086 |
| 93769-5 | 56-711-085 |
| 93769-6 | 56-711-014-LI |
| 93769-7 | 56-711-012-LI |
| 93769-8 | 56-711-040-LI |
| 93769-9 | 56-711-086-LI |
| 93770-1 | 56-721-014 |
| 93770-2 | 56-721-012 |
| 93770-3 | 56-721-045 |
| 93770-4 | 56-721-112 |
| 93770-5 | 56-721-070 |
| 93770-6 | 56-721-014-LI |
| 93770-7 | 56-721-012-LI |
| 93770-8 | 56-721-045-LI |
| 93770-9 | 56-721-112-LI |
| 93771-1 | 56-731-014 |
| 93771-2 | 56-731-012 |
| 93771-3 | 56-731-040-LI |

| AMP Part Number | API Part Number |
|-----------------|-----------------|
| 93771-4 | 56-731-077 |
| 93771-5 | 56-731-060 |
| 93771-6 | 56-731-014-LI |
| 93771-7 | 56-731-012-LI |
| 93771-8 | 56-731-040-LI |
| 93771-9 | 56-731-077-LI |
| 93772-1 | 56-706-004 |
| 93772-2 | 56-706-002 |
| 93772-3 | 56-706-006 |
| 93772-4 | 56-706-017 |
| 93772-5 | 56-706-009 |
| 93772-6 | 56-706-004-LI |
| 93772-7 | 56-706-002-LI |
| 93772-8 | 56-706-006-LI |
| 93772-9 | 56-706-017-LI |
| 93773-1 | 56-716-004 |
| 93773-2 | 56-716-002 |
| 93773-3 | 56-716-006 |
| 93773-4 | 56-716-013 |
| 93773-5 | 56-716-009 |
| 93773-6 | 56-716-004-LI |
| 93773-7 | 56-716-002-LI |
| 93773-8 | 56-716-006-LI |
| 93773-9 | 56-716-013-LI |
| 93774-1 | 56-726-004 |
| 93774-2 | 56-726-002 |
| 93774-3 | 56-726-006 |
| 93774-4 | 56-726-021 |
| 93774-5 | 56-726-009 |
| 93774-6 | 56-726-004-LI |
| 93774-7 | 56-726-002-LI |
| 93774-8 | 56-726-006-LI |
| 93774-9 | 56-726-021-LI |
| 93775-1 | 56-736-004 |
| 93775-2 | 56-736-002 |
| 93775-3 | 56-736-006 |
| 93775-4 | 56-736-015 |
| 93775-5 | 56-736-009 |
| 93775-6 | 56-736-004-LI |
| 93775-7 | 56-736-002-LI |
| 93775-8 | 56-736-006-LI |
| 93775-9 | 56-736-015-LI |

* There may be mechanical and/or electrical differences between the Amp and Spectrum part. Please consult factory.

** A standard part number does not currently exist but will be assigned upon ordering.

Surface Mount EMI Filters

our family of surface mount filters is designed to provide a range of high performance EMI filtering options with a minimal PCB footprint

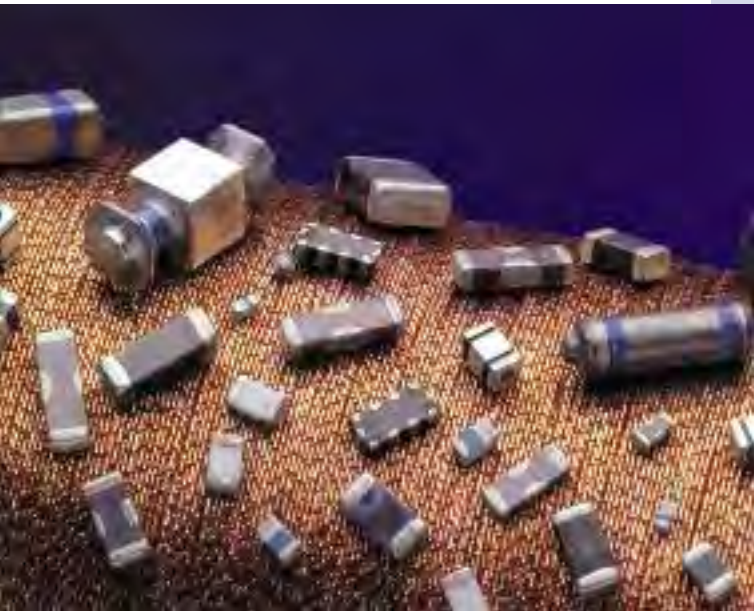

Advantages of a Surface Mount Filter

With many years of experience in the design and manufacture of filters, API Technologies has a unique perspective on EMI and how to control it. We provide an integrated approach to EMC problems with services such as customer consulting, diagnostic testing, design and manufacturing. By offering a variety of custom assemblies, we are able to unite your specific requirements with our high performance filters.

API's Spectrum Control line of surface mount EMI filters are ideal for a wide range of PCB applications, including: automotive electronics, digital AV equipment, computers, peripherals, telecommunications, switching power supplies and high current buss lines.

Three Terminal Chips offer superior ability to withstand transient voltages and surges, and deliver excellent filtering performance in high current applications while providing exceptional solderability and resistance to solder heat... **SM2-SM7**

SA Series Arrays incorporate four lines in one compact footprint. These arrays are nonpolar and designed to minimize residual inductance, thereby ensuring large insertion loss in a wide band and better cross talk control... **SM8-SM9**

MSM Mini-Surface Mount offers a multilayer electrode structure, high temperature construction and 10 Amps current ratings. The filter chips provide extreme elimination of residual inductance and the self-resonant frequency extends the microwave band... **SM11**

SSM Square Surface Mount square mechanical geometry enhances SMT soldering in applications up to 10 Amps. These filters come in a Pi circuit configuration and are designed to address EMI/RFI on crowded printed circuit boards... **SM12-SM13**

PSM Power Surface Mount are the first high temperature surface mount filter designed to effectively filter EMI/RFI at currents up to 20 Amps. These filters come in either a Feed-through or Pi circuit configuration and offer superior high frequency noise suppression... **SM14-SM15**

MSP Mini Surface Mount Power Filters offers a multilayer electrode structure, high temperature construction and 10 Amps current ratings. The filter chips provide extreme elimination of residual inductance and the self-resonant frequency extends to the microwave band... **SM16**

MPC Series Miniature PCB Power Filters are designed to fit a wide range of environments. These filters are ideal for personal computers and peripherals, home appliances, measuring instruments and medical equipment, and are all available lead free... **SM17-SM20**

High Frequency PCB Filters provide EMI filtering to protect low power digital circuits. With mounting directly on the printed circuit board, filtering begins at the source of the problem... **SM21**



Surface Mount EMI Filters Three Terminal Chips

Features

- Excellent performance in high current applications
- Non-polar, surface mountable
- Superior filtering characteristics
- Superb ability to withstand transient voltages and surge
- Offers exceptional solderability and resistance to solder heat
- Available in 0603, 0805, 1205 and 1806 body size
- Two amp current rating available
- Available lead free/RoHS Compliant

Applications

- Cellular telephones and base stations
- Telecommunication equipment
- Industrial electronic interface or programmable controllers
- Electronic automotive equipment
- Computer and peripheral equipment



Circuit Schematic

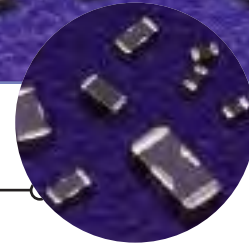
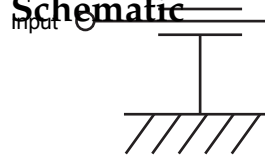

Typical Electrical Characteristics

Capacitance Range COG (NPO) 22 pF to 470 pF
 X7R 470 pF to 47,000 pF
 YV5 100,000 pF and 220,000 pF

Capacitance Tolerance COG (NPO) +50/-20%
 X7R +50/-20%
 Y5V +80/-20%

Temperature Coefficient COG (NPO) 0 ±30 ppm/°C, -55 to +125°C
 X7R +/-15%, -55 to +125°C
 Y5V -25 to +85°C

Insulation Resistance up to 22,000 pF 10000 Megohms
 47,000 pF 5000 Megohms

DC Resistance 0.4 Amp or less 0.3 ohm max.
 1 Amp 0.08 ohm max.
 2 Amp 0.04 ohm max.

Rated Voltage up to 100 VDC

Rated Current up to 2 Amps

Surface Mount EMI Filters Three Terminal Chips

Selection Guide

| Part Number | Body Size | Capacitance (in picofarad) | Capacitance Tolerance | Temp. Charact. | Rated Voltage (Volts DC) | Rated Current (Amps DC) | IR (Megohms Min.) | DC Resistance (ohm Max.) | Operating Temp. |
|--|-------------|----------------------------|-----------------------|----------------|--------------------------|-------------------------|-------------------|--------------------------|-------------------|
| SF0603C220SBNB-* | 0603 | 22 | +50/-20% | COG | 50 | 0.3 | 10,000 | 0.3 | -55/+125°C |
| SF0603C470SBNB-* | 0603 | 47 | +50/-20% | COG | 50 | 0.3 | 10,000 | 0.3 | -55/+125°C |
| SF0603C101SBNB-* | 0603 | 100 | +50/-20% | COG | 50 | 0.3 | 10,000 | 0.3 | -55/+125°C |
| SF0603C221SBNB-* | 0603 | 220 | +50/-20% | COG | 50 | 0.3 | 10,000 | 0.3 | -55/+125°C |
| SF0603X471SBNB-* | 0603 | 470 | +50/-20% | X7R | 50 | 0.3 | 10,000 | 0.3 | -55/+125°C |
| SF0603X102SBNB-* | 0603 | 1,000 | +50/-20% | X7R | 50 | 0.3 | 10,000 | 0.3 | -55/+125°C |
| SF0603X222SBNB-* | 0603 | 2,200 | +50/-20% | X7R | 50 | 0.3 | 10,000 | 0.3 | -55/+125°C |
| SF0603X223SANC-* | 0603 | 22,000 | +50/-20% | X7R | 25 | 0.5 | 10,000 | 0.15 | -55/+125°C |
| SF0603Y104MAND-* | 0603 | 100,000 | ±20% | Y5V† | 25 | 1 | 1,000 | 0.08 | -25/+85°C |
| SF0805C220SBNC-* | 0805 | 22 | +50/-20% | COG | 50 | 0.4 | 10,000 | 0.3 | -55/+125°C |
| SF0805C470SBNC-* | 0805 | 47 | +50/-20% | COG | 50 | 0.4 | 10,000 | 0.3 | -55/+125°C |
| SF0805C101SBNC-* | 0805 | 100 | +50/-20% | COG | 50 | 0.4 | 10,000 | 0.3 | -55/+125°C |
| SF0805C221SBNC-* | 0805 | 220 | +50/-20% | COG | 50 | 0.4 | 10,000 | 0.3 | -55/+125°C |
| SF0805X471SBNC-* | 0805 | 470 | +50/-20% | X7R | 50 | 0.4 | 10,000 | 0.3 | -55/+125°C |
| SF0805X102SBNC-* | 0805 | 1,000 | +50/-20% | X7R | 50 | 0.4 | 10,000 | 0.3 | -55/+125°C |
| SF0805X222SBNC-* | 0805 | 2,200 | +50/-20% | X7R | 50 | 0.4 | 10,000 | 0.3 | -55/+125°C |
| SF0805X223SBND-* | 0805 | 22,000 | +50/-20% | X7R | 50 | 1.0 | 10,000 | 0.08 | -55/+125°C |
| SF1205C220SBNB-* | 1205 | 22 | +50/-20% | COG | 50 | 0.3 | 10,000 | 0.3 | -55/+125°C |
| SF1205C470SBNB-* | 1205 | 47 | +50/-20% | COG | 50 | 0.3 | 10,000 | 0.3 | -55/+125°C |
| SF1205C101SBNB-* | 1205 | 100 | +50/-20% | COG | 50 | 0.3 | 10,000 | 0.3 | -55/+125°C |
| SF1205C221SBNB-* | 1205 | 220 | +50/-20% | COG | 50 | 0.3 | 10,000 | 0.3 | -55/+125°C |
| SF1205X471SBNB-* | 1205 | 470 | +50/-20% | X7R | 50 | 0.3 | 10,000 | 0.3 | -55/+125°C |
| SF1205X102SBNB-* | 1205 | 1,000 | +50/-20% | X7R | 50 | 0.3 | 10,000 | 0.3 | -55/+125°C |
| SF1205X222SBNB-* | 1205 | 2,200 | +50/-20% | X7R | 50 | 0.3 | 10,000 | 0.3 | -55/+125°C |
| SF1205X223SBNB-* | 1205 | 22,000 | +50/-20% | X7R | 50 | 0.3 | 10,000 | 0.3 | -55/+125°C |
| SF1205X473SBND-* | 1205 | 47,000 | +50/-20% | X7R | 50 | 1.0 | 5,000 | 0.08 | -55/+125°C |
| SF1806C220SDNB-* | 1806 | 22 | +50/-20% | COG | 100 | 0.3 | 10,000 | 0.3 | -55/+125°C |
| SF1806C470SDNB-* | 1806 | 47 | +50/-20% | COG | 100 | 0.3 | 10,000 | 0.3 | -55/+125°C |
| SF1806C101SDNB-* | 1806 | 100 | +50/-20% | COG | 100 | 0.3 | 10,000 | 0.3 | -55/+125°C |
| SF1806C221SDNB-* | 1806 | 220 | +50/-20% | COG | 100 | 0.3 | 10,000 | 0.3 | -55/+125°C |
| SF1806C471SDNB-* | 1806 | 470 | +50/-20% | COG | 100 | 0.3 | 10,000 | 0.3 | -55/+125°C |
| SF1806X102SDNB-* | 1806 | 1,000 | +50/-20% | X7R | 100 | 0.3 | 10,000 | 0.3 | -55/+125°C |
| SF1806X222SDNB-* | 1806 | 2,200 | +50/-20% | X7R | 100 | 0.3 | 10,000 | 0.3 | -55/+125°C |
| SF1806X103SDNB-* | 1806 | 10,000 | +50/-20% | X7R | 100 | 0.3 | 10,000 | 0.3 | -55/+125°C |
| SF1806X223SDNB-* | 1806 | 22,000 | +50/-20% | X7R | 100 | 0.3 | 10,000 | 0.3 | -55/+125°C |
| 2 AMP FILTER SF1806Y224ZBNE-* | 1806 | 220,000 | +80/-20% | Y5V† | 50 | 2.0 | 1,000 | 0.04 | -25/+85°C |

Bold Letter = High Current Applications
† = Temperature Characteristic is +30/-80%

* = Denotes Packaging Style. Replace with T for Tape and Reel or B for Bulk

Surface Mount EMI Filters Three Terminal Chips

Insertion Loss (Per MIL-STD-220)

SF0603 Series

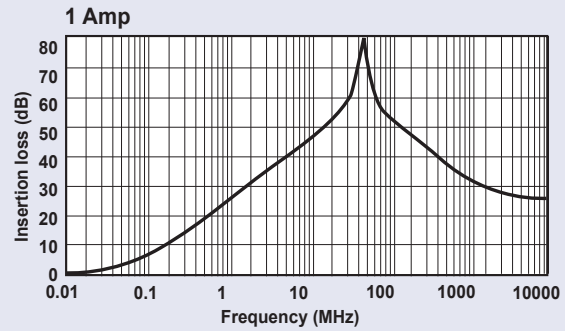
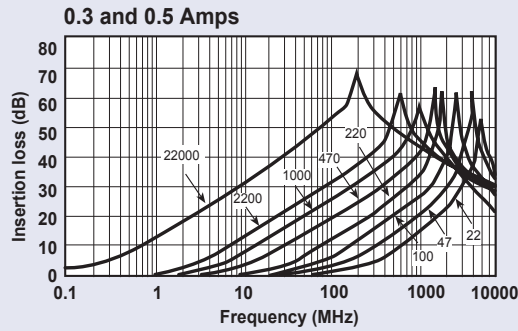

SF0805 Series

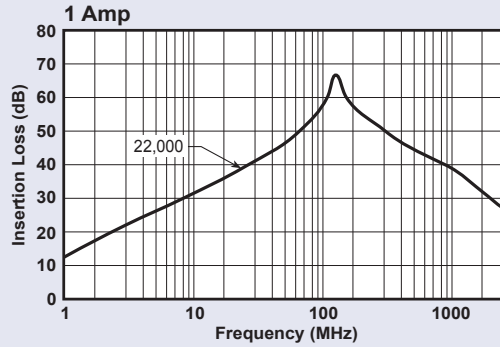
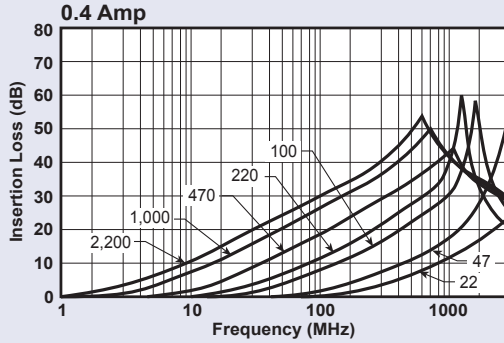

SF1205 Series

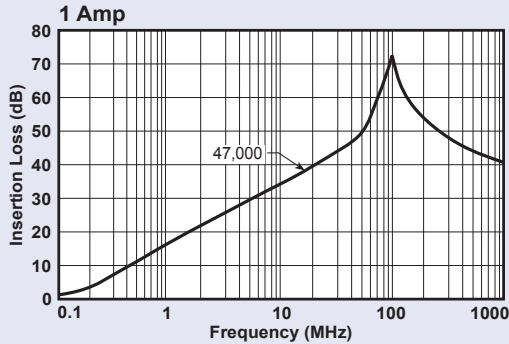
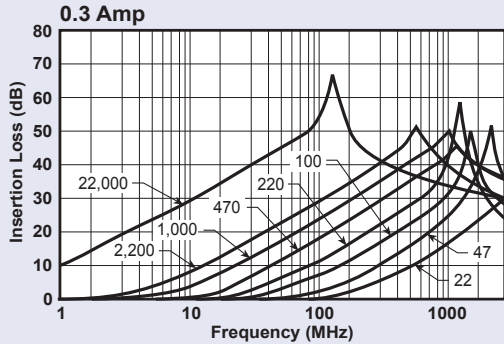

SF1806 Series

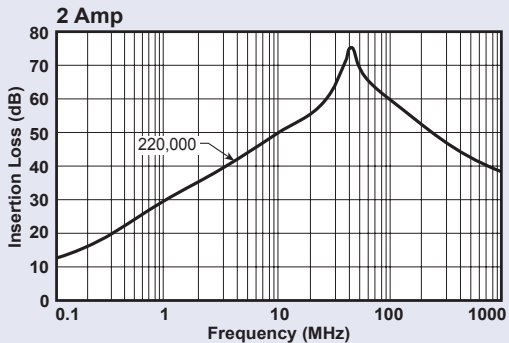
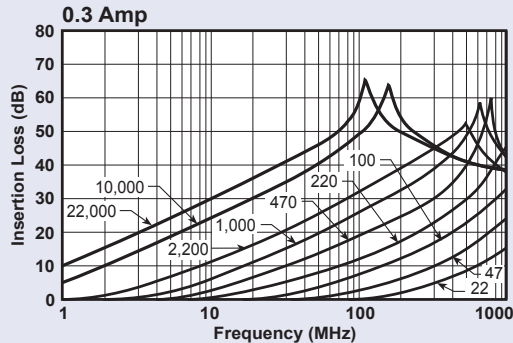

Surface Mount EMI Filters Three Terminal Chips

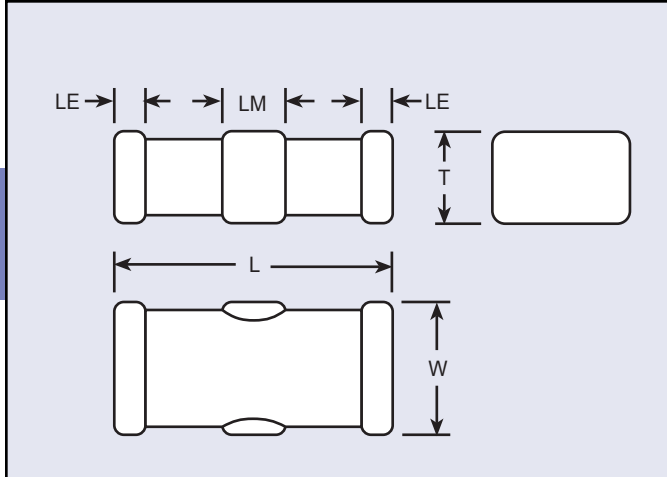

Mechanical Dimensions

Dimensions in inches (mm)

| Body Style/Size | Body Length (L) | Body Width (W) | Body Thickness (T) | End Terminal Length (LE) | Middle Terminal Length (LM) |
|-----------------|----------------------------------|----------------------------------|---------------------------------|---------------------------------|---------------------------------|
| SF0603 | 0.063 +/-0.006 (1.60 +/-0.15) | 0.031 +/-0.006 (0.80 +/-0.15) | 0.023 +/-0.006 (0.6 +/-0.15) | 0.008 +/-0.006 (0.2 +/-0.15) | 0.020 +/-0.006 (0.5 +/-0.15) |
| SF0805 | 0.079 +/-0.008 (2.0 +/-0.2) | 0.049 +/-0.008 (1.25 +/-0.2) | 0.032 +/-0.008 (0.8 +/-0.2) | 0.012 +/-0.008 (0.3 +/-0.2) | 0.024 +/-0.008 (0.6 +/-0.2) |
| SF1205 | 0.126 +/-0.008 (3.2 +/-0.2) | 0.049 +/-0.008 (1.25 +/-0.2) | 0.028 +/-0.008 (0.7 +/-0.2) | 0.016 +/-0.012 (0.4 +/-0.3) | 0.043 +/-0.012 (1.1 +/-0.3) |
| SF1806 | 0.177 +/-0.012 (4.5 +/-0.3) | 0.063 +/-0.012 (1.6 +/-0.3) | 0.039 +/-0.012 (1.0 +/-0.3) | 0.020 +/-0.012 (0.5 +/-0.3) | 0.055 +/-0.012 (1.4 +/-0.3) |

Ordering Information

Example: **SF0805C221SBNCT**

This part number represents a three terminal chip with a body size of 0805 with a COG (NPO) dielectric. The capacitance is 220 pF with a capacitance tolerance of +50%/-20%. Voltage rating is 50 Volts DC. It has nickel barrier, solder plated terminations and a current rating of 0.4 Amp, (400 milliamps). The parts are taped and reeled.

| SF | 0805 | C | 221 | S | B | N | C | T |
|-------|------------------------------|-------------------------------|--|--------------------------------|-----------------------------|-------------------------------------|--|-----------------------------|
| Style | Size | Ceramic | Capacitance Code | Capacitance Tolerance | Rated Voltage (Vdc) | Termination | Current Rating | Packaging |
| SF | 0603 0805 1205 1806 | C - COG X - X7R Y - Y5V | First two numbers are significant, the third number refers to number of zeroes | S - +50%/-20% Z - +80%/-20% | A - 25 B - 50 D - 100 | N - Ni Barrier, Solder Plated | B - 0.3 A C - 0.4 A D - 1 A E - 2 A F - 3 A G - 4 A H - 5 A I - 6 A | T - Tape & Reel B - Bulk |

Surface Mount EMI Filters Three Terminal Chips Soldering Specifications

Soldering Instructions

Reflow Soldering

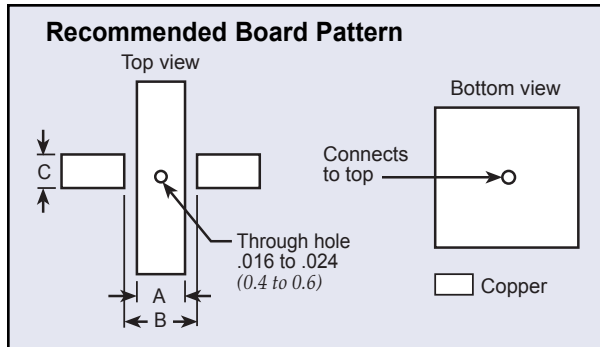

Board Pattern Dimensions in inches (mm)

| Body Style/Size | Dimension | | |
|-----------------|----------------|----------------|----------------|
| | A | B | C |
| SF0603 | 0.020 (0.5) | 0.047 (1.2) | 0.031 (0.8) |
| SF0805 | 0.024 (0.6) | 0.059 (1.5) | 0.039 (1.0) |
| SF1205 | 0.051 (1.3) | 0.091 (2.3) | 0.047 (1.2) |
| SF1806 | 0.079 (2.0) | 0.138 (3.5) | 0.051 (1.3) |

Reflow Soldering

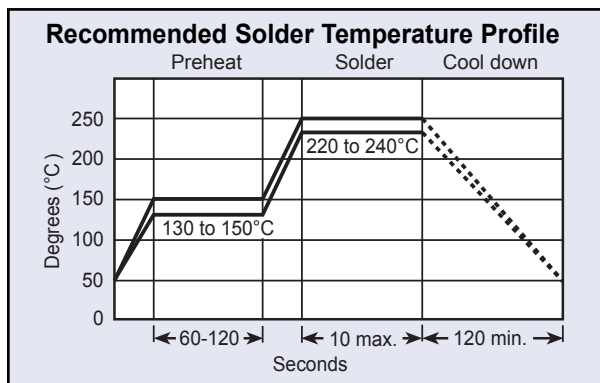

General Soldering Notes

1. High soldering temperatures and long soldering times can cause leaching of the termination and adversely affect adhesion. These conditions can also decrease capacitance value. Use the above recommended solder temperature cycle.
2. Due to the mechanical characteristic of ceramic composition, aggressive thermal shock will degrade performance. Preheat the assembly before soldering using the above solder temperature profile as a guide.

Flow Soldering

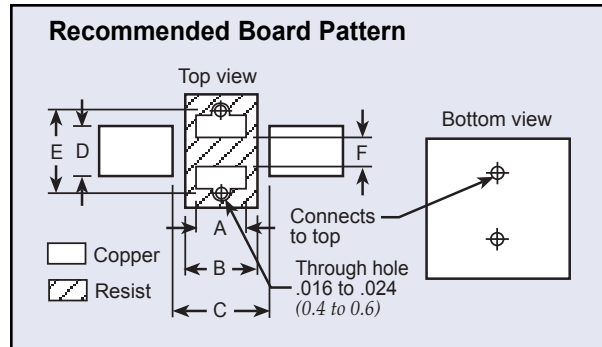

Board Pattern Dimensions in inches (mm)

| Body Style/Size | Dimension | | | | | |
|-----------------|----------------|----------------|----------------|----------------|----------------|----------------|
| | A | B | C | D | E | F |
| SF0603 | 0.020 (0.5) | 0.031 (0.8) | 0.047 (1.2) | 0.031 (0.8) | 0.071 (1.8) | 0.016 (0.4) |
| SF0805 | 0.024 (0.6) | 0.031 (0.8) | 0.059 (1.5) | 0.039 (1.0) | 0.087 (2.2) | 0.024 (0.6) |
| SF1205 | 0.051 (1.3) | 0.059 (1.5) | 0.091 (2.3) | 0.047 (1.2) | 0.118 (3.0) | 0.024 (0.6) |
| SF1806 | 0.059 (1.5) | 0.079 (1.5) | 0.138 (3.5) | 0.051 (1.3) | 0.118 (3.0) | 0.024 (0.6) |

Flow Soldering

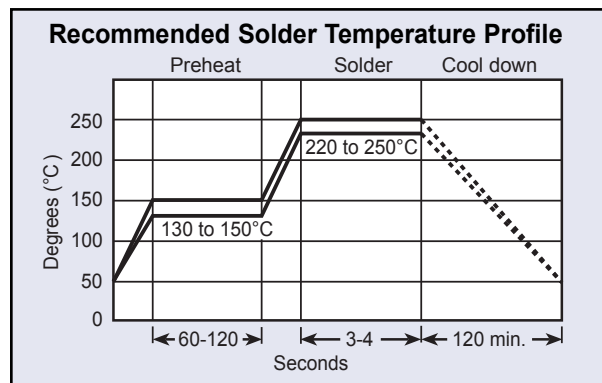

3. Use mild flux (less than 0.2% by weight of Chlorine), preferable rosin based. If water soluble, wash thoroughly to assure all residue is removed from the underside of components.
4. Ultrasonic Cleaning
When using an ultrasonic cleaning method, the following range is recommended:
Frequency: Not to exceed 28kHz
Output Power: Not to exceed 20W/liter
Cleaning Time: 5 minutes max

Surface Mount EMI Filters
Three Terminal Chips
Soldering Specifications

Package Quantities

| Body Style/Size | Tape and Reel |
|-----------------|------------------|
| SF0603 | 4,000 units/reel |
| SF0805 | 4,000 units/reel |
| SF1205 | 4,000 units/reel |
| SF1806 | 2,000 units/reel |

Package Information
Paper Tape Dimensions
SF0805 and SF1205 Bodies

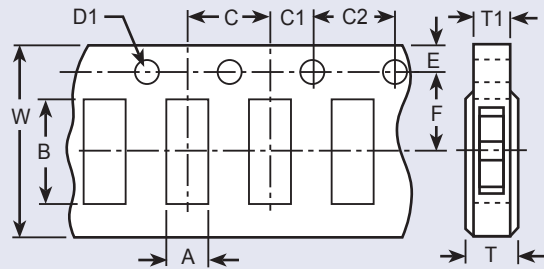

Dimensions in inches (mm)

| Body Style/Size | Chip Cavity | | Tape | | | Holes | | | Hole Diameter | | Thickness | |
|-----------------|------------------------------------|-----------------------------------|-----------------------------------|------------------------------------|------------------------------------|-----------------------------------|-----------------------------------|-----------------------------------|---------------------------------------|-------------|------------------|------------------------|
| | Length A | Width B | Width W | Center to End F | Indexing to End E | Center to Center C | Indexing to Center C1 | Indexing to Indexing C2 | Center D (Min.) | Indexing D1 | Overall T (Max.) | Carrier Tape T1 (Max.) |
| SF0603 | 0.039 +/-0.00? (1.0 +/-0.?) | 0.075 +/-0.00? (1.9 +/-0.?) | 0.315 +/-0.012 (8.0 +/-0.3) | 0.138 +/-0.002 (3.5 +/-0.05) | 0.069 +/-0.004 (1.75 +/-0.1) | 0.157 +/-0.004 (4.0 +/-0.1) | 0.079 +/-0.004 (2.0 +/-0.1) | 0.157 +/-0.008 (4.0 +/-0.1) | 0.059 +0.004/-0 (1.5 +/-0.1/-0) | | 0.043 (1.1) | 0.039 (1.0) |
| SF0805 | 0.064 +/-0.008 (1.62 +/-0.2) | 0.091 +/-0.008 (2.3 +/-0.2) | 0.315 +/-0.012 (8.0 +/-0.3) | 0.138 +/-0.002 (3.5 +/-0.05) | 0.069 +/-0.004 (1.75 +/-0.1) | 0.157 +/-0.004 (4.0 +/-0.1) | 0.079 +/-0.004 (2.0 +/-0.1) | 0.157 +/-0.008 (4.0 +/-0.1) | 0.059 +0.004/-0 (1.5 +/-0.1/-0) | | 0.043 (1.1) | 0.039 (1.0) |
| SF1205 | 0.067 +/-0.008 (1.70 +/-0.2) | 0.138 +/-0.008 (3.5 +/-0.2) | 0.315 +/-0.012 (8.0 +/-0.3) | 0.138 +/-0.002 (3.5 +/-0.05) | 0.069 +/-0.004 (1.75 +/-0.1) | 0.157 +/-0.004 (4.0 +/-0.1) | 0.079 +/-0.004 (2.0 +/-0.1) | 0.157 +/-0.008 (4.0 +/-0.1) | 0.059 +0.004/-0 (1.5 +/-0.1/-0) | | 0.043 (1.1) | 0.039 (1.0) |

Plastic Reel Dimensions

Dimensions in inches (mm)

| Body Style/Size | Diameter (Max.) | Width (Max.) |
|-----------------|-----------------|--------------|
| SF0603 | 7.00 (180) | 0.46 (11.5) |
| SF0805 | 7.00 (180) | 0.46 (11.5) |
| SF1205 | 7.00 (180) | 0.46 (11.5) |
| SF1806 | 7.00 (180) | 0.61 (11.5) |

Package Information
Tape and Reel Specification
Plastic Carrier Tape Dimensions
SF1806 Body

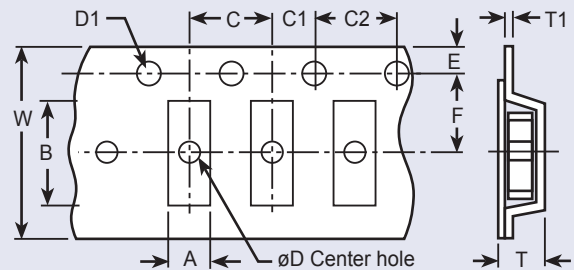

Dimensions in inches (mm)

| Body Style/Size | Chip Cavity | | Tape | | | Holes | | | Hole Diameter | | Thickness | |
|-----------------|------------------------------------|------------------------------------|------------------------------------|------------------------------------|------------------------------------|-----------------------------------|-----------------------------------|-----------------------------------|-----------------|---------------------------------------|------------------|----------------|
| | Length A | Width B | Width W | Center to End F | Indexing to End E | Center to Center C | Indexing to Center C1 | Indexing to Indexing C2 | Center D (Min.) | Indexing D1 | Overall T (Max.) | Tape T1 (Max.) |
| SF1806 | 0.071 +/-0.008 (1.80 +/-0.2) | 0.185 +/-0.008 (4.70 +/-0.2) | 0.472 +/-0.008 (12.0 +/-0.2) | 0.217 +/-0.002 (5.5 +/-0.05) | 0.069 +/-0.004 (1.75 +/-0.1) | 0.157 +/-0.004 (4.0 +/-0.1) | 0.079 +/-0.004 (2.0 +/-0.1) | 0.157 +/-0.008 (4.0 +/-0.1) | 0.059 (1.5) | 0.059 +0.004/-0 (1.5 +/-0.1/-0) | 0.098 (2.5) | 0.024 (0.6) |

Surface Mount Filter Arrays SA Series

Features

- The filter's structure minimizes residual inductance with a high self resonant frequency, ensuring large insertion loss in a wide band.
- The common ground electrode built into the chip ensures complete grounding of all lines at the ground on both ends. The filter is designed to control cross talk.
- An optimum constant can be selected from the capacity range of 22-22,000 pF to best suit the frequency.
- Solder plated nickel barrier terminations offer good solderability and resistance to soldering heat.
- Available lead free/RoHs compliant

Applications

- Noise reduction for DC lines on computers
- Computer peripheral equipment
- Digital TV & VTR
- Cellular telephones
- Automotive electronics

Typical Electrical Characteristics

Rated Voltage 25 VDC to 50 VDC
 Rated Current 0.3 Amps
 IR 10,000 MΩ Min.
 DC Resistance 0.3 Ω Max.
 Temperature Range -55°C to +125°C
 Capacitance Range 22 pF to 22,000 pF
 Capacitance Tolerance ±20%

Specifications

| Part Number | Rated Voltage (@ 50/60Hz) | Rated Current | Temperature Characteristic | IR | DC Resistance | Operating Temp | Capacitance (pF) |
|-------------|---------------------------|---------------|----------------------------|----------------|---------------|----------------|------------------|
| SA1206C220 | 50 VDC | 0.3A DC | C | 10,000 MΩ min. | 0.3Ω max. | -55/+125°C | 22 |
| SA1206C470 | | | C | | | | 47 |
| SA1206C101 | | | C | | | | 100 |
| SA1206C221 | | | C | | | | 220 |
| SA1206R471 | | | U | | | | 470 |
| SA1206R102 | | | R | | | | 1,000 |
| SA1206R222 | | | R | | | | 2,200 |
| SA1206R223 | 25 VDC | | R | | | | 22,000 |



Circuit Schematic

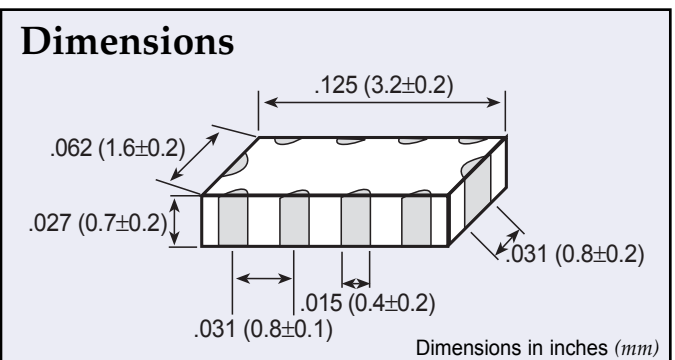
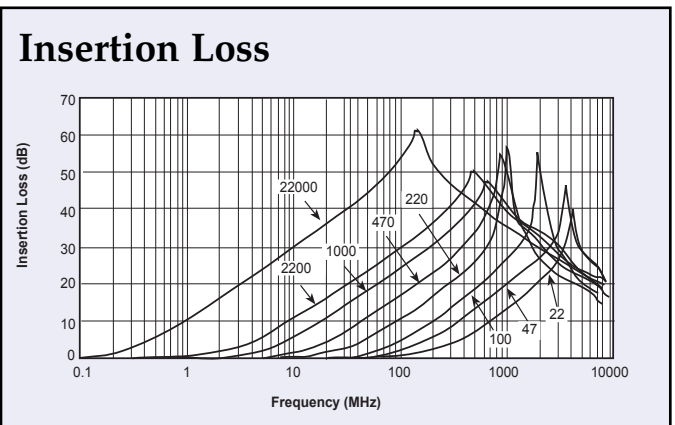
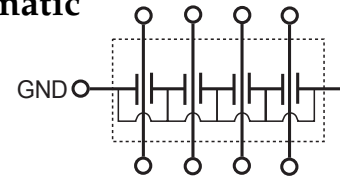

Surface Mount Filter Arrays SA Series

Ordering Information

| SA | 1206 | C | 220 | M | B | N | B |
|-----------|------|---|---|-----------------------|---------------------|---------------------------------|--|
| Style | Size | Temperature Characteristics | Capacitance | Capacitance tolerance | Rated Voltage (Vdc) | Termination | Packaging |
| SA Series | 1206 | C +/- 30 ppm/°C R +/- 15% U -750 +/- 120 ppm/°C | 22 pF 47 pF 100 pF 220 pF 470 pF 1,000 pF 2,200 pF 22,000 pF | M = ± 20% | A = 25 B = 50 | N = Ni Barrier Solder Plated | T - Tape and reel 4,000 pc/reel B - Bulk pack 1,000 pcs/bag |

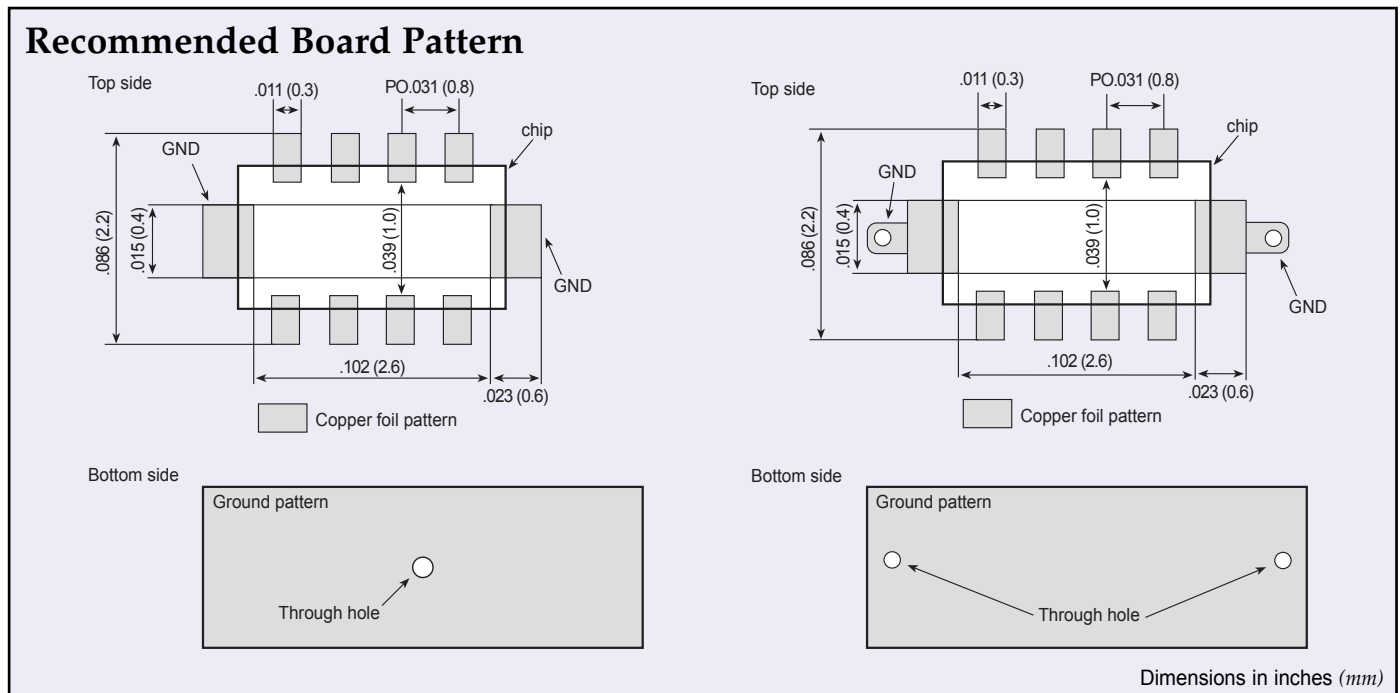
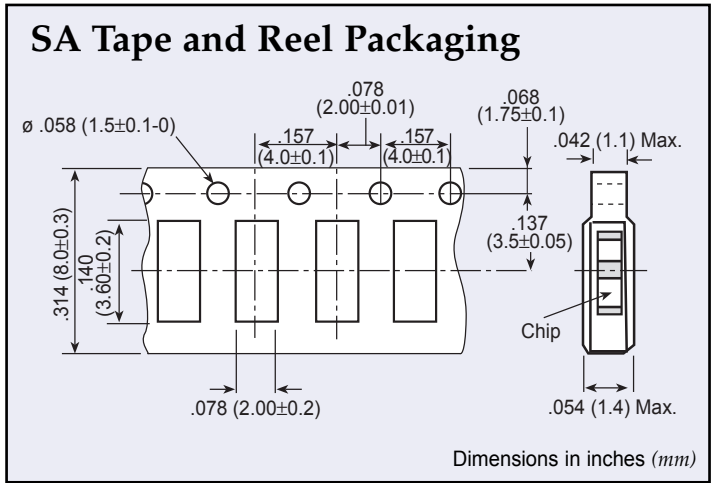

Surface Mount Low Pass Filters MSM, SSM, RSM & PSM Series

MSM - Miniature Surface Mount Chip Capacitors



The MSM series filters feature high temperature construction and have current ratings up to 10 Amps. The filter chips will hardly allow residual inductance and the self-resonant frequency extends to the microwave band. Applications include telecommunication equipment, computer and peripheral equipment and digital AV equipment, medical equipment, DC power supply lines.

- Miniature footprint help in dense circuit configuration
- Rated at 10 Amps
- Packaged in tape and reel or bulk form
- Operating temperature ranges of -25°C to +85°C and -55°C to +125°C
- Available lead free/RoHs compliant

SSM - Square Surface Mount Filters



The SSM series filters feature high temperature construction and have current ratings up to 10 Amps. This filter chip series is nonpolar and surface mountable with excellent performance characteristics and comes in a Pi circuit configuration. Applications include telecommunication equipment, computer and peripheral equipment, digital AV equipment, power amplifiers, power supplies and high current bus lines.

- Square mechanical geometry enhances SMT soldering
- Rated to 10 Amps
- Packaged in tape and reel or bulk form
- Operating temperature range of -55°C to +125°C
- Available lead free/RoHs compliant

RSM - Round Surface Mount Filters



The RSM series filters feature high temperature construction and have current ratings up to 10 Amps. This filter chip series is nonpolar and surface mountable with excellent performance characteristics and comes in a Pi circuit configuration. Applications include telecommunication equipment, computer and peripheral equipment, digital AV equipment, power amplifiers, power supplies and high current bus lines.

- Round mechanical geometry enhances SMT soldering
- Rated to 10 Amps
- Packaged in tape and reel or bulk form
- Operating temperature range of -55°C to +125°C
- Available lead free/RoHs compliant

PSM - Power Surface Mount Filters



The PSM series filters feature high temperature construction and have current ratings up to 20 Amps. This filter series is nonpolar and surface mountable with excellent performance characteristics and comes in either a Feed-through or Pi circuit configuration. Applications include telecommunication equipment, computer and peripheral equipment, digital AV equipment, power amplifiers, power supplies and high current bus lines.

- Provides time and costs saving compared to through-hole filters
- Rated to 20 Amps
- Packaged in tape and reel or bulk form
- Operating temperature range of -55°C to +125°C
- Available lead free/RoHs compliant

Surface Mount Low Pass Filters
MSM Series

MSM

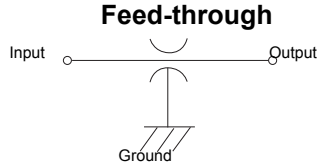

Working Voltage 50 VDC
 Test Voltage 150 VDC
 Current Rating 10 Amps max.
 Insulation Resistance 1.0 MΩ
 Terminations Ni-Barrier
 Soldering Conditions Max. 250°C-5 sec.

Insertion Loss

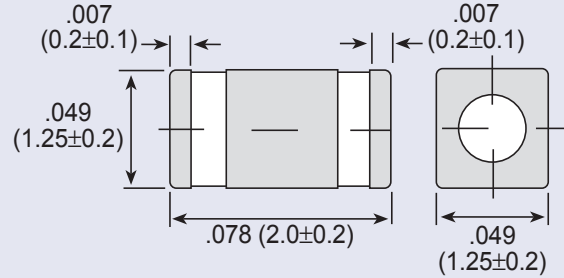
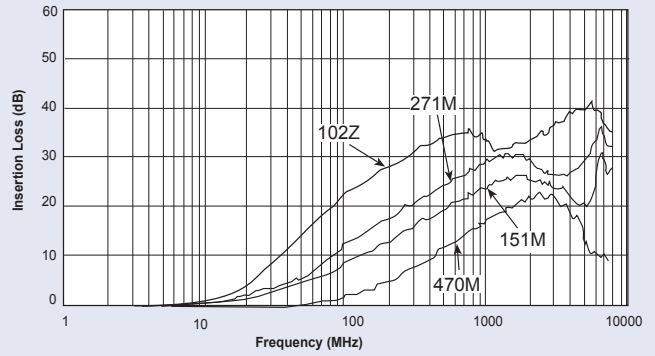

MSM

Dimensions in inches (mm)

MSM Ordering Information

MSM

Style

MSM
(Miniature)

4

Circuit Configuration
4 - Feed-Through

T

Temperature Characteristic
R - +/-15%
T - +22/-33%
V - +22/-82%

470M

Capacitance

| Value | Tolerance |
|-------|-----------|
| 47 pF | +50/- 20% |

10

Current Rating
10 Amps

T

Packaging

T - Tape and Reel
2,000 pcs/reel
B - Bulk pack
1,000pcs/reel

Specifications

| Part Number | Temperature Characteristics | Capacitance | Capacitance Tolerance | Current Rating | Rated Rating | Temperature Range |
|-------------|-----------------------------|-------------|-----------------------|----------------|--------------|-------------------|
| MSM4T470M10 | T | 47pF | +50/-20% | 10A | 50VDC | -55/+125°C |
| MSM4R151M10 | R | 150pF | | | | -55/+125°C |
| MSM4R271M10 | R | 270pF | | | | -55/+125°C |
| MSM4V102M10 | V | 1000pF | | | | -25/+85°C |

MSM Recommended Board Pattern

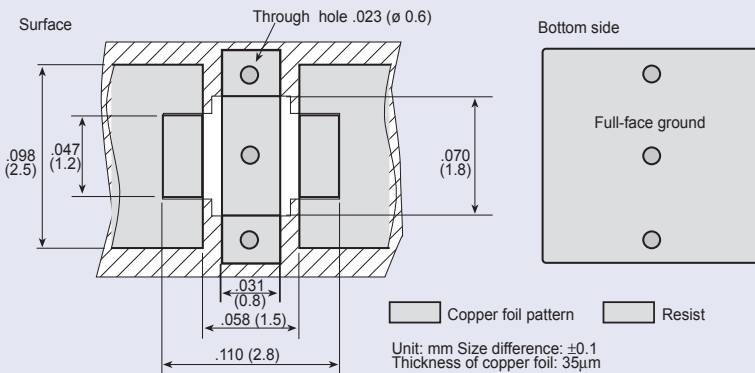

Note: Exclusively for reflow soldering

MSM Tape and Reel Packaging

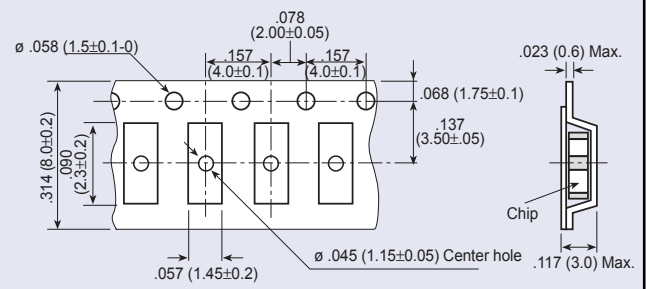

Surface Mount Low Pass Filters SSM & RSM Series

SSM

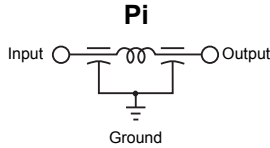

- Working Voltage 100 VDC
- Test Voltage 250 VDC
- Current Max. 10 Amps
- Insulation Resistance Min. 10^4 M Ω
- Terminations Silver Ni-Tin plated
- Soldering Conditions Max. 250°C -5 sec.
- Marking None
- Packaging Bulk or tape and reel

Note: Insertion loss shown for the following SSM values* only:

- 101Z
- 501P
- 202P

*Additional IL charts available by request.

RSM

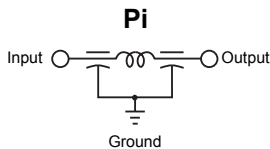

- Working Voltage 100 VDC
- Test Voltage 250 VDC
- Current Max. 10 Amps
- Insulation Resistance Min. 10^4 M Ω
- Terminations Silver Ni-Tin plated
- Soldering Conditions Max. 250°C -5 sec.
- Marking None
- Packaging Bulk or tape and reel

Note: Insertion loss shown for the following RSM values only:

- 152P
- 402Z

Pi Insertion Loss

Typical SMT Applications

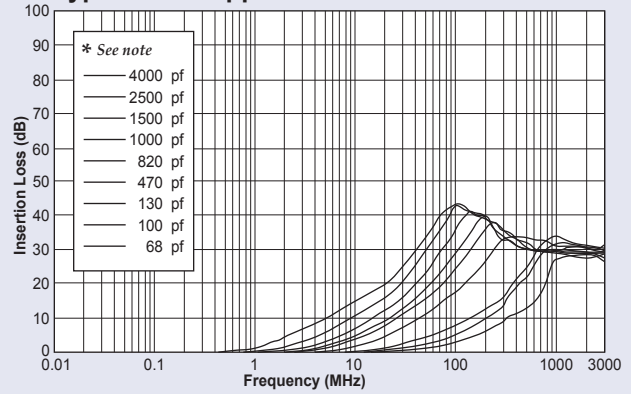

Shielded or Partition Applications

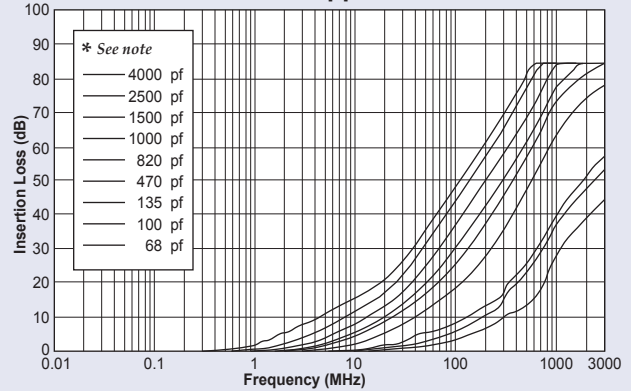

* Capacitance values for insertion loss curves are displayed left to right in the order shown.

SSM

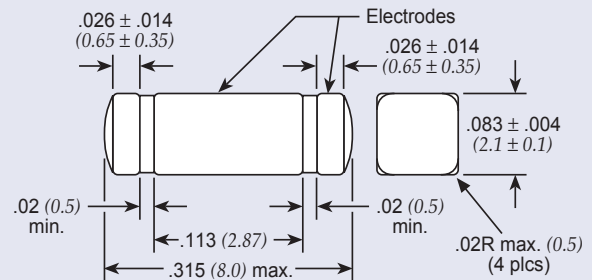

RSM

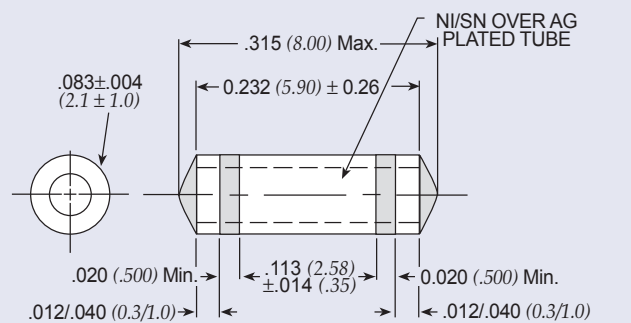

Dimensions in inches (mm)

Surface Mount Low Pass Filters SSM & RSM Series

SSM & RSM Ordering Information

Example: **SSM1-101Z-05T**

| | | | | | |
|-----------------------------|-----------------------|-------------|-----------------------------|---|---|
| SSM | 1 | 101Z | 05 | T | 1 |
| Style | Circuit Configuration | Capacitance | Current Rating | Packaging | Tape and Reel |
| SSM (Square) RSM (Round) | 1 - Pi | | 05 - 5 Amps 10 - 10 Amps | T - Tape and reel packaging B - Bulk packaging | 1 - 1,000 pieces 6 - 6,000 pieces <i>Note: Tape and reel packaging - 1,000 pieces (7") and 6,000 pieces (13")</i> |

| Code | Value | Tolerance |
|------|---------|-----------|
| 101Z | 100 pF | +80/-20% |
| 501P | 500 pF | +100/-0% |
| 152P | 1500 pF | +100/-0% |
| 202P | 2000 pF | +100/-0% |
| 402E | 4000 pF | ±25 |
| 402Z | 4000 pF | +80/-20% |

† Also available through API's authorized distributors.
 € Also available through API's authorized European distributors/agents.
 † SSM1-152P-05-T1 €

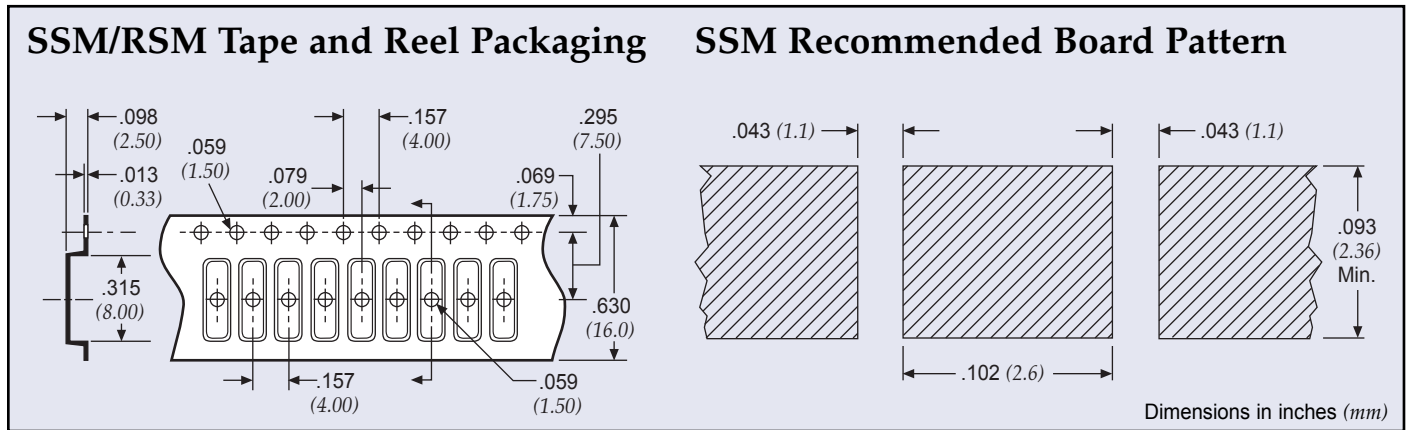

Surface Mount Low Pass Filters PSM Series

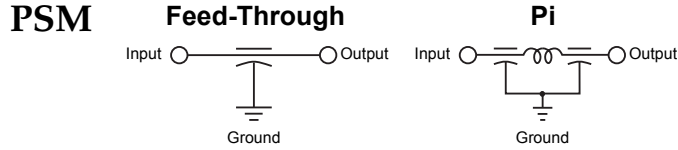

- Voltage Rating DC 200 VDC @ -55°C to +125°C
- DWV 700 VDC
- Current Rating 20 Amps (Feed-through) max.
10 Amps (Pi) max.
- Insulation Resistance 1.0 GΩ @ 25°C
- Dissipation Factor 4.0% maximum
- D.C.R. Max. .0005Ω, typ. .0002Ω

* AC rated parts available. Please consult factory.

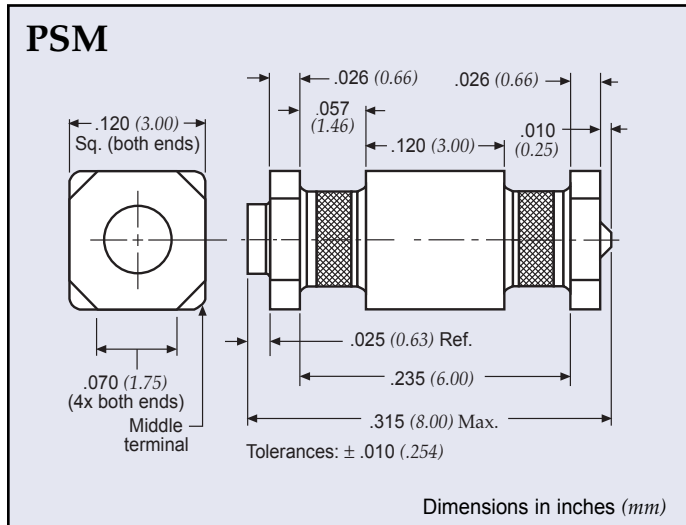

Feed-Through Insertion Loss

Typical SMT Applications

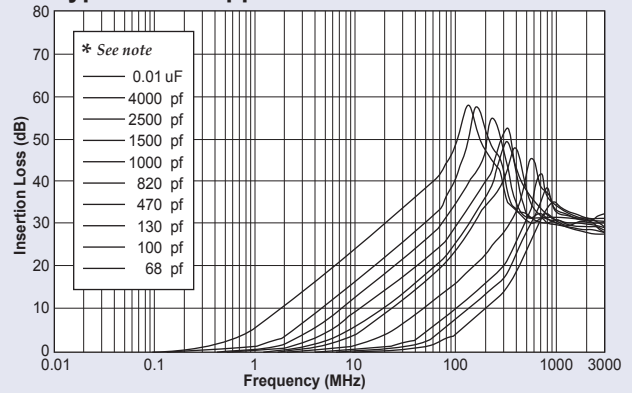

Shielded or Partition Applications

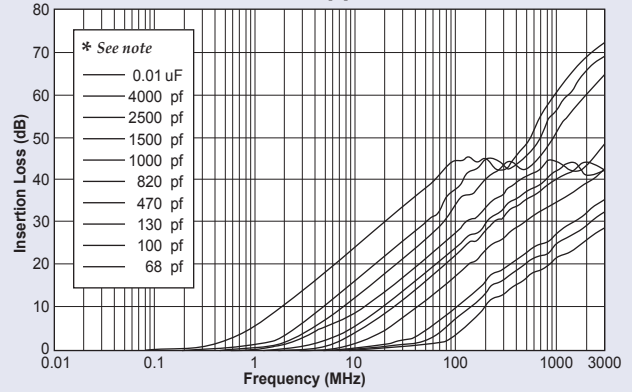

* Capacitance values for insertion loss curves are displayed left to right in the order shown.

Pi Insertion Loss

Typical SMT Applications

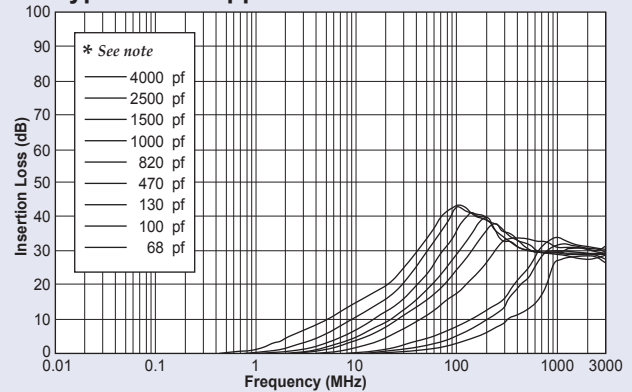

Shielded or Partition Applications

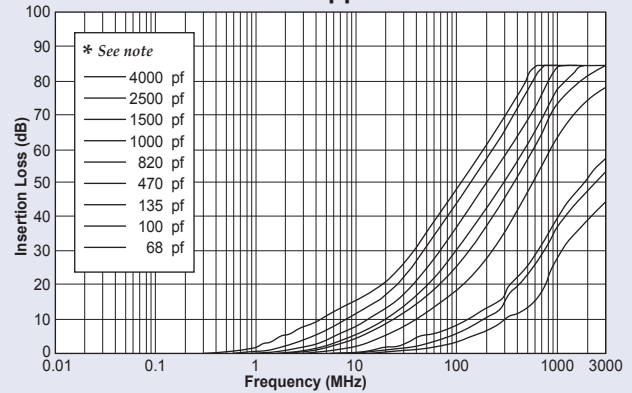

Surface Mount Low Pass Filters PSM Series

PSM Ordering Information

Example: **PSM4-402Z-20T0**

| PSM | 4 | - | 402Z | - | 20 | T | 0 | | | | | | | | | | | | | | | | | | | | | | | | | | | | | | | | | |
|---|----------------------------|-----------|---|------|--|---|---|-------|------|------|--------|------|------|--------|----------|------|--------|----------|------|--------|------|------|---------|------|------|---------|------|------|---------|----------|------|---------|---------|--------|--------|----------|--|--|--|--|
| Style | Circuit Configuration | | Capacitance | | Current Rating | Packaging | Tape and Reel | | | | | | | | | | | | | | | | | | | | | | | | | | | | | | | | | |
| PSM (Power) | 1 - Pi 4 - Feed-through | | | | 10 - 10 Amps (Pi) 20 - 20 Amps (Feed-through) | T - Tape and reel packaging B - Bulk packaging | 0 - 500 pieces 2 - 2,000 pieces <i>Note: Tape and reel packaging - 500 pieces (7") and 2,000 pieces (13")</i> | | | | | | | | | | | | | | | | | | | | | | | | | | | | | | | | | |
| | | | <table border="1"> <thead> <tr> <th>Code</th> <th>Value*</th> <th>Tolerance</th> </tr> </thead> <tbody> <tr><td>680M</td><td>68 pF</td><td>±20%</td></tr> <tr><td>101M</td><td>100 pF</td><td>±20%</td></tr> <tr><td>131P</td><td>130 pF</td><td>+100/-0%</td></tr> <tr><td>471P</td><td>470 pF</td><td>+100/-0%</td></tr> <tr><td>821M</td><td>820 pF</td><td>±20%</td></tr> <tr><td>102M</td><td>1000 pF</td><td>±20%</td></tr> <tr><td>152M</td><td>1500 pF</td><td>±20%</td></tr> <tr><td>252P</td><td>2500 pF</td><td>+100/-0%</td></tr> <tr><td>402Z</td><td>4000 pF</td><td>+80/20%</td></tr> <tr><td>103Z**</td><td>.01 μF</td><td>+80/-20%</td></tr> </tbody> </table> | Code | Value* | Tolerance | 680M | 68 pF | ±20% | 101M | 100 pF | ±20% | 131P | 130 pF | +100/-0% | 471P | 470 pF | +100/-0% | 821M | 820 pF | ±20% | 102M | 1000 pF | ±20% | 152M | 1500 pF | ±20% | 252P | 2500 pF | +100/-0% | 402Z | 4000 pF | +80/20% | 103Z** | .01 μF | +80/-20% | | | | |
| Code | Value* | Tolerance | | | | | | | | | | | | | | | | | | | | | | | | | | | | | | | | | | | | | | |
| 680M | 68 pF | ±20% | | | | | | | | | | | | | | | | | | | | | | | | | | | | | | | | | | | | | | |
| 101M | 100 pF | ±20% | | | | | | | | | | | | | | | | | | | | | | | | | | | | | | | | | | | | | | |
| 131P | 130 pF | +100/-0% | | | | | | | | | | | | | | | | | | | | | | | | | | | | | | | | | | | | | | |
| 471P | 470 pF | +100/-0% | | | | | | | | | | | | | | | | | | | | | | | | | | | | | | | | | | | | | | |
| 821M | 820 pF | ±20% | | | | | | | | | | | | | | | | | | | | | | | | | | | | | | | | | | | | | | |
| 102M | 1000 pF | ±20% | | | | | | | | | | | | | | | | | | | | | | | | | | | | | | | | | | | | | | |
| 152M | 1500 pF | ±20% | | | | | | | | | | | | | | | | | | | | | | | | | | | | | | | | | | | | | | |
| 252P | 2500 pF | +100/-0% | | | | | | | | | | | | | | | | | | | | | | | | | | | | | | | | | | | | | | |
| 402Z | 4000 pF | +80/20% | | | | | | | | | | | | | | | | | | | | | | | | | | | | | | | | | | | | | | |
| 103Z** | .01 μF | +80/-20% | | | | | | | | | | | | | | | | | | | | | | | | | | | | | | | | | | | | | | |
| † Also available through API's authorized distributors. | | | * Other capacitance values available as special order. ** Available in Feed-through circuit only. | | | | | | | | | | | | | | | | | | | | | | | | | | | | | | | | | | | | | |

Technical Notes

- Soldering recommendations supplied upon request
- Reflow temperature limit is 250°C
- Unit weight is approximately 0.4 grams
- Tape and reel packaging available for automated assembly

PSM Tape and Reel Packaging

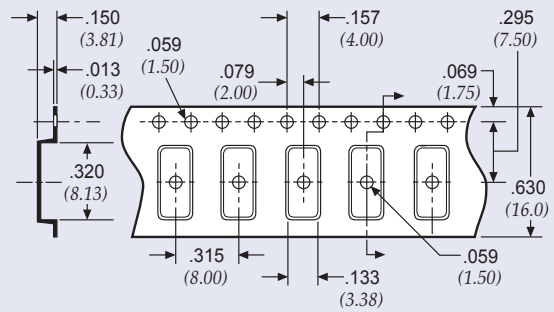

PSM Recommended Board Pattern

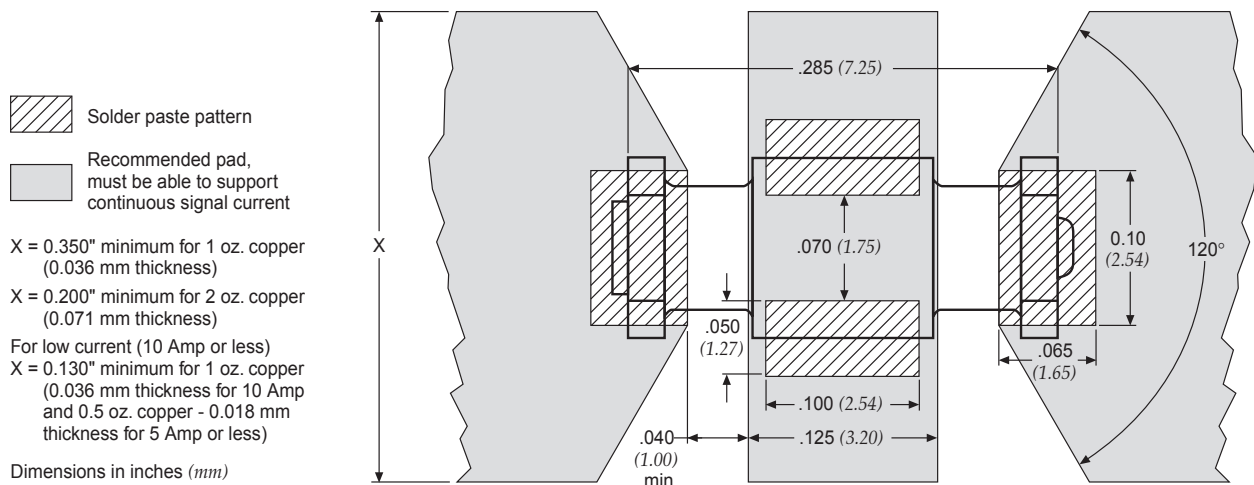

Mini Surface Mount Power Filters MSP Series

Features

- Designed for 10A DC power lines
- Offers high insertion loss in a wide frequency band by combining feed-through capacitors, multilayer ceramic capacitors and ferrite bead inductors with high self resonance frequency.
- Compact EMI package with plus and minus lines

Applications

- Electronic measuring instruments
- Industrial equipment
- Automotive electronics
- Switching power supplies
- DC-DC converters



Circuit Schematic

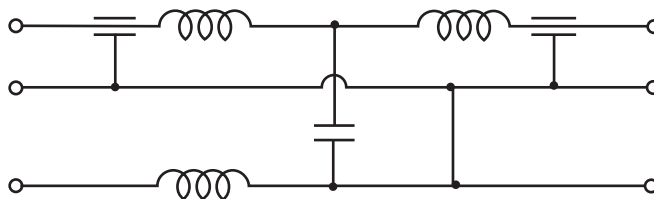

Dimensions

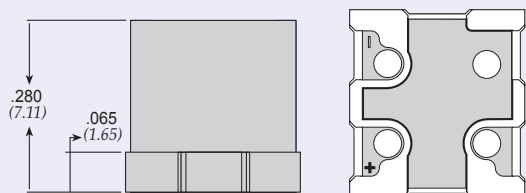
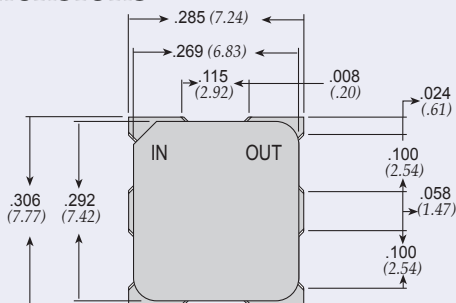

Dimensions in inches (mm)

Insertion Loss

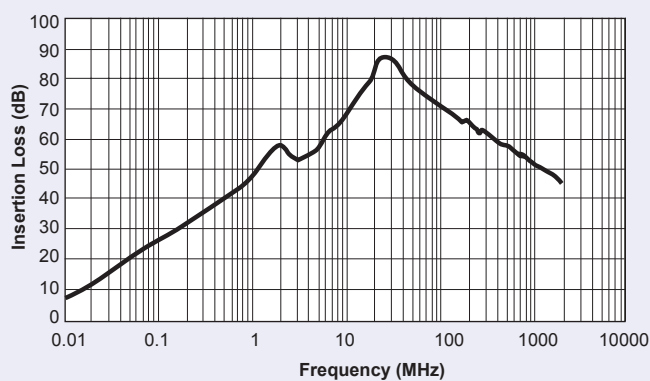

Specifications

| Model | Rated Voltage | Rated Current | Max. DCR | Temperature Range |
|-------------|---------------|---------------|----------|-------------------|
| MSP-007-050 | 50VDC | 10A | 5 MΩ | -25°C ~ +105°C |

Miniature PCB Power Filters MPC Series



Tested and found to be
IAW VDE 0565 Part 3

61-MPC Series

Rugged construction design enables parts to perform in industrial environments. The 61-MPC series is ideally suited for products that must conform to FCC part 15 regulations. Agency approvals: UL recognized, CSA certified, TUV approved (tested and found to be in accordance with VDE 0565 Part 30). Applications include:

- Personal computers and peripherals
- Measuring instruments
- Home appliances and vacuum cleaners
- Monitor and display units
- Switching power supplies
- Available lead free/RoHs compliant

11-MPC Series

Power filters are available in PCB mount, bolt-in, fast-on tab or solder lug. The 11-MPC series is ideally suited for products that have been limited board space and require a low cost alternative. Available in both metal and plastic cases. Applications include:

- Personal computers and peripherals
- Digital equipment
- Measuring instruments and medical equipment
- TV & VCR monitors and display units
- Available lead free/RoHs compliant

MPC-010/-015 Series

The compact design of the MPC-010 and -015 series power filters integrates a feed-through capacitor, multilayer ceramic capacitor and ferrite bead inductors. This series is ideally suited for dense PCB's and where both positive and negative lines have reduced EMI in one housing. Applications include:

- DC power lines on industrial equipment
- Measuring instruments
- Home appliances and vacuum cleaners
- Monitor and display units
- Switching power supplies
- Available lead free/RoHs compliant



Circuit Diagrams

Circuit 1

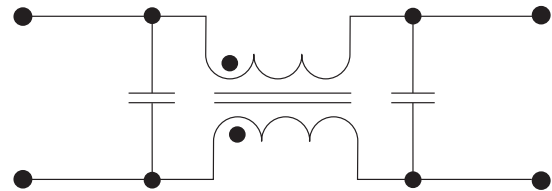

Circuit 2

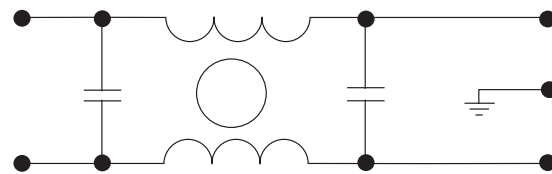

Circuit 3

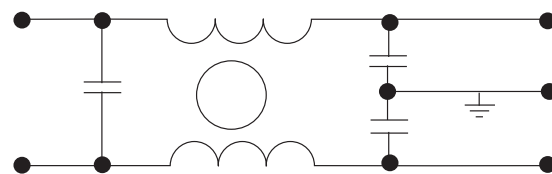

Circuit 4

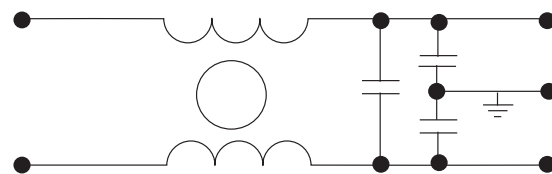

Circuit 5

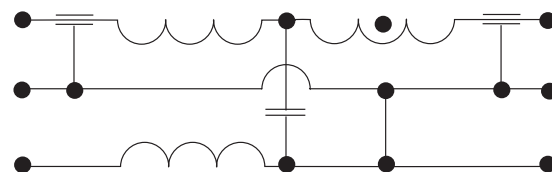

Miniature PCB Power Filters MPC Series

Specifications

| Model | Rated Voltage (@ 50/60Hz) | Rated Current | Leakage Current (Max.) | Inductance (L ₁) | Temperature Rise (Max.) | Circuit Diagram | Figure |
|-----------------|---------------------------|---------------|------------------------|------------------------------|-------------------------|-----------------|--------|
| 61-MPC-010-1-11 | 250VAC | 1A | 0.1mA | 11mH | 40°C | 1 | A |
| 61-MPC-016-1-11 | | 1.6A | | 6.0mH | | | |
| 61-MPC-025-1-11 | | 2.5A | | 2.4mH | | | |
| 61-MPC-036-1-11 | | 3.6A | | 1.2mH | | | |
| 11-MPC-001-2-B | 120/250VAC | 1A | 5uA | — | 30°C | 2 | C |
| 11-MPC-001-5-A | | | | | | 3 | B |
| 11-MPC-001-5-B | | | | | | | C |
| 11-MPC-002-5-B | | 2A | 0.50mA | | | 4 | E |
| 11-MPC-002-5-D | | | | | | F | |
| 11-MPC-003-5-E | | 3A | 3 | | | C | |
| 11-MPC-006-5-B | | 6A | | | | D | |
| 11-MPC-006-5-C | | 16A | | | | C | |
| 11-MPC-016-5-B | 16A | 0.2mA | 4 | C | | | |
| MPC-010-050 | 50 VDC | 10A | — | — | — | 5 | G |
| MPC-010-250 | 250 VDC | | | | | | |
| MPC-015-050 | 50VDC | | | | | | |

Note: Test voltage: 1500VAC one minute, line to ground. Insulation resistance: 300 MΩ min. at 500VDC. Voltage drop: 1V max. at rated current. Weight: 17.5g

Figure A

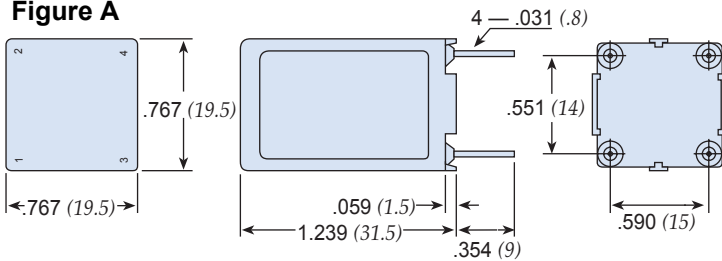

Figure B

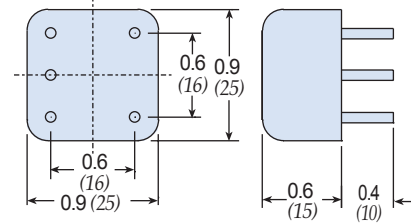

Figure C

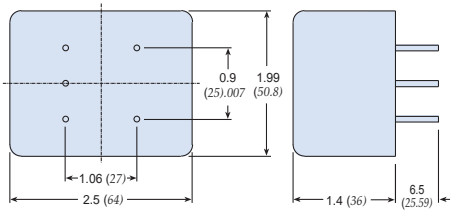

Figure D

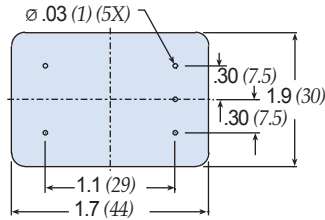

Figure E

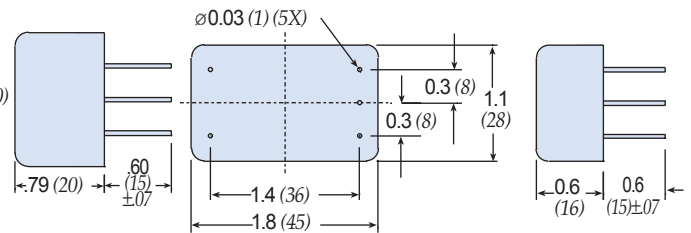

Figure F

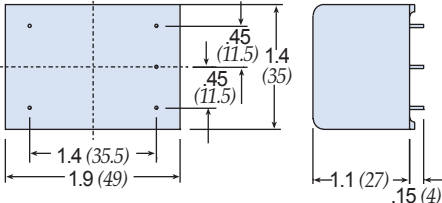
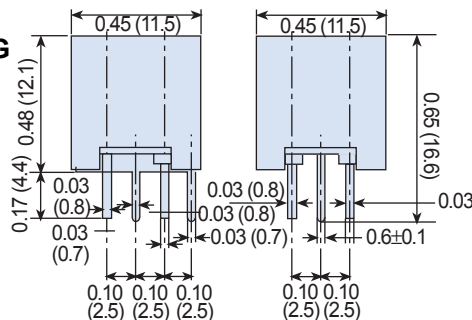

Figure G



Dimensions in inches (mm)

Miniature PCB Power Filters MPC Series

61-MPC Series

Common Mode

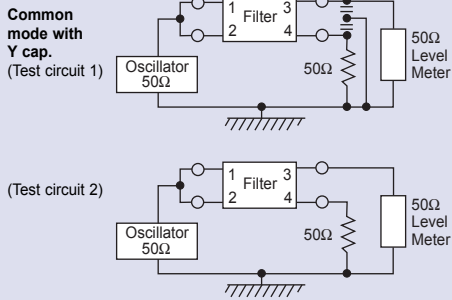

61-MPC

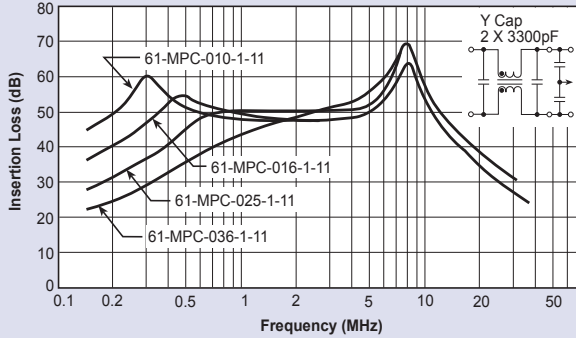

61-MPC

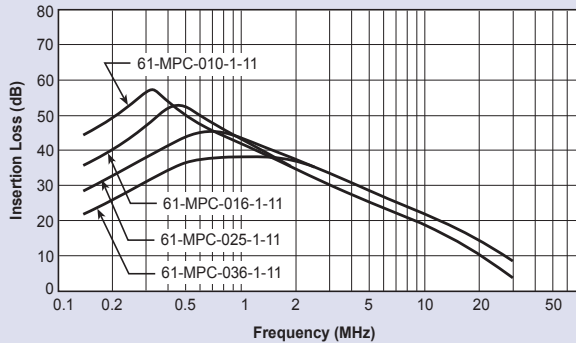

Temperature Characteristics

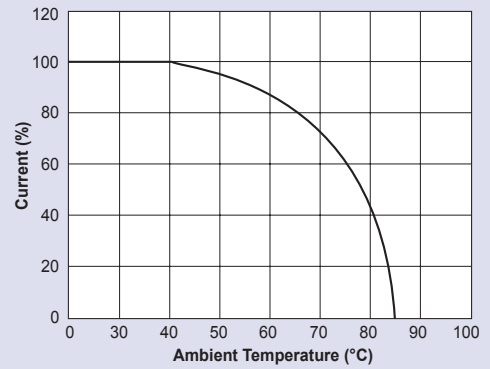

Normal Mode

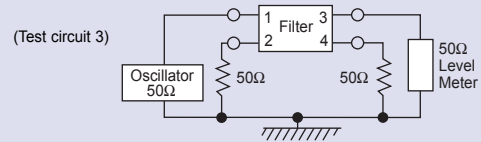

61-MPC

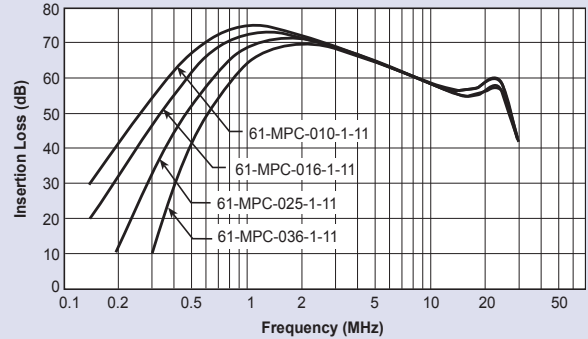

Miniature PCB Power Filters MPC Series

11-MPC Series

Common Mode

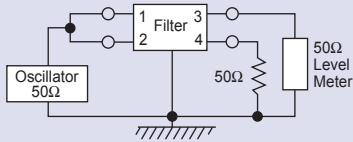

11-MPC-001;-002

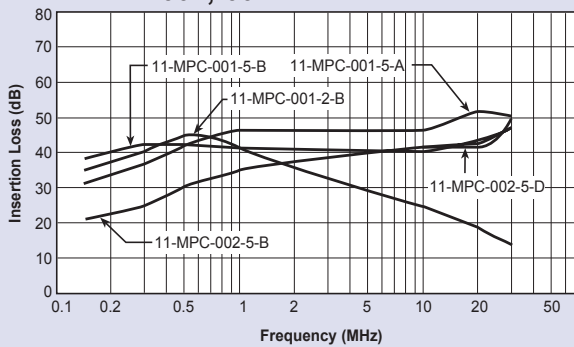

11-MPC-003;-006;-016

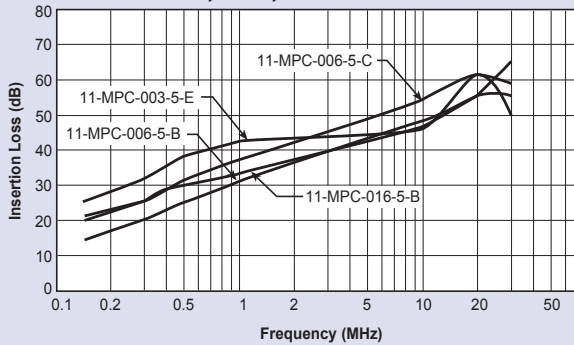

Normal Mode

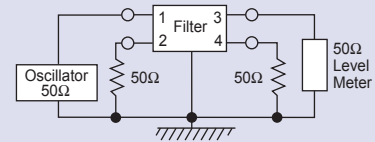

11-MPC-001;-002

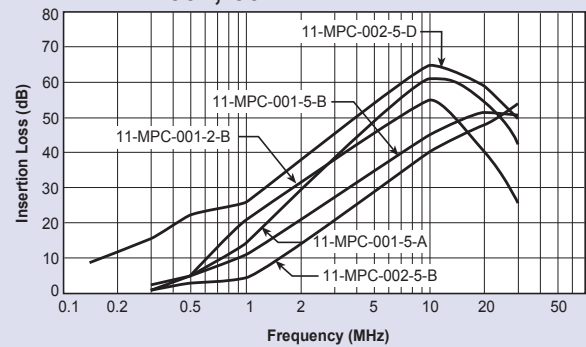

11-MPC-003;-006;-016

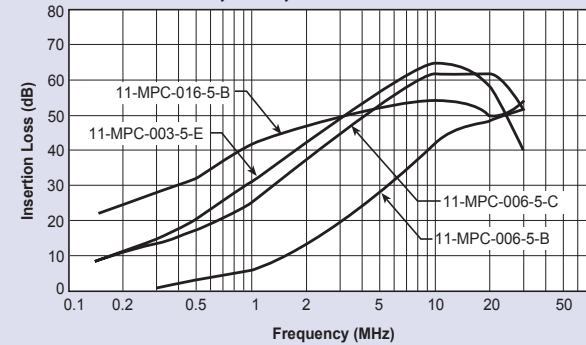

MPC-010 & 015 Series

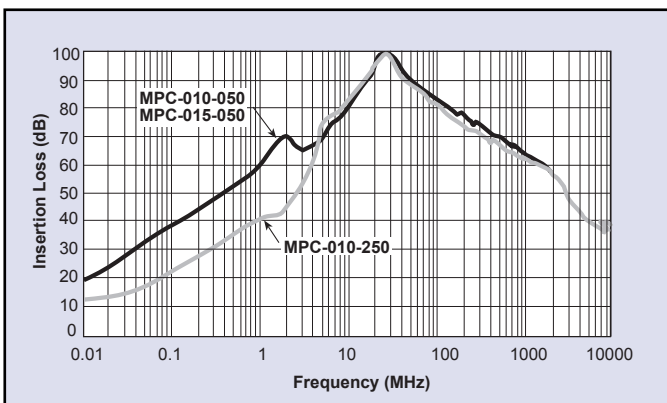

Through-hole Filters High Frequency PCB Filters

API Technologies' Spectrum Control line of high frequency PCB filter provides EMI filtering to protect low power digital circuits, while meeting most government and industrial specifications for EMI control. With low assembly and installation costs, the PCB filter helps keep your project on budget. By mounting the PCB filter at the source of the problem, we eliminate the need for additional filtering at other points in the circuit. The filter mounts directly to a printed circuit board with no mounting bracket or plate needed, providing you with a lower total installed cost. In addition, the PCB filter can be flow-soldered with other components.

API's PCB filter has built-in standoffs, which allow for cleaning or coating beneath the filter, and the filter is encapsulated for environmental protection.

Features

- Provides EMI filtering to protect low power digital circuits - helps equipment meet FCC and VDE specifications
- Mounts directly to printed circuit board with no bracket or plate for lower applied costs - can be flow soldered with other components
- Encapsulated for environmental protection
- Mounts on PCB to begin filtering at the source of the problem
- Built-in standoffs permit cleaning or coating under the filter

Circuit Schematic

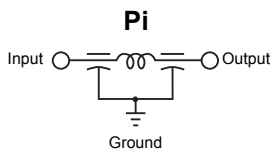

Typical Electrical Characteristics

Current Max. 10A DC; 0.3A RF
 Operating Voltage Max. 50 VDC, -25°C to +85°C
 Capacitance 800 pF min.
 Dissipation Factor 0.1 Max.
 Dielectric
 Withstanding Voltage 125 VDC for 5 seconds
 Insulation Resistance Min. 100 MegOhms at 100 VDC for 2 minutes and 25°C

Direct Current
 Resistance 0.002 ohms Max.
 Minimum No-Load
 Insertion Loss Per MIL-STD-220 at 25°C; PCB mounted, 50 ohm strip line

3dB @ 8 MHz
 10dB @ 25 MHz
 15dB @ 50 MHz
 20dB @ 100 MHz-1GHz

Preformed to Recommended Mounting Configuration Part Number 842448-2

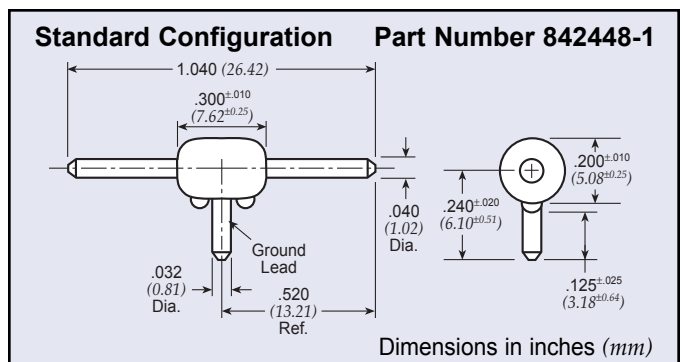
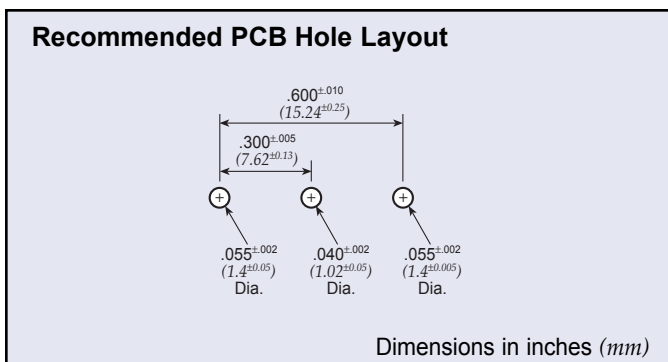
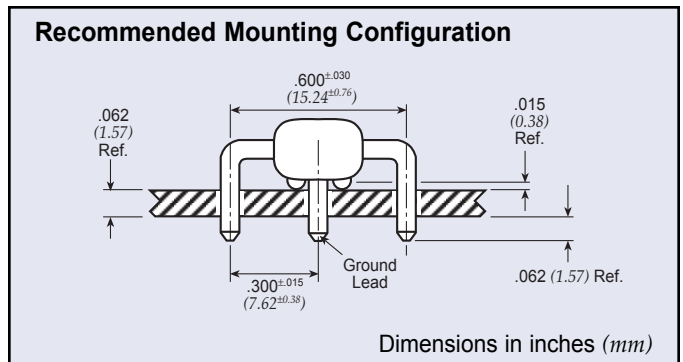

Low Pass EMI Filters

the industry's most complete line of EMI filters gives you more style, size, IL performance and cost alternatives



Low Pass EMI Advantages

API Technologies' Spectrum Control brand was founded in 1968 as a designer and manufacturer of Electromagnetic Interference (EMI) filters. Today, API continues that work, combining knowledge with excellence. These many years of experience have yielded an engineering-driven team that understands how and where potential EMI problems exist in an electronic system and how to best eliminate them. With an extensive library of standard products and a willingness to develop an application-specific custom solution, our customers count on us to help them satisfy global EMC standards while meeting demanding design parameters.

Motor Line Feed-Through (MLFT) Filters are high capacitance filters specifically designed for DC motor and other lower voltage applications. This one-component solution addresses EMI noise issues and eliminates the need for multiple components and electrical connections... **LP2**

Solder-In Filters offer an ideal solution for applications in critical areas where space does not allow for use of mounting tools or hardware. Available in C, Pi and standard L circuit configurations and primarily used in filtering signal/data lines and AC power lines... **LP3-LP7**

9900 Series Filters have a knurled design allowing them to be pressed into place creating a reliable mechanical bond making them an excellent choice for applications where soldering is undesirable... **LP8-LP11**

Spec Spin Filters are an excellent choice for applications that require many lines to be filtered in close proximity to each other due to their space saving #2-56 threaded miniature EMI spinner design. These filters are designed without a hex and do not require soldering for installation... **LP12**

Resin Sealed Filters provide excellent environmental protection in a rugged case that is resin sealed at both ends and easily mounted with a tapped hole or through hole. These filters are provided in C, L and Pi configurations with metric threading available... **LP13-LP24**

High Current Resin Sealed Filters are ideal for use in high current 5 volt logic buss, as well as ± 48 VDC telephone rack buss, high current switch mode power supplies and DC charging systems. These filters feature rugged bolt-in style for easy installation... **LP25-LP26**

Hermetically Sealed Filters feature hermetic glass seals and high EMI filtering performance making them highly reliable in the toughest environmental conditions. These filters are available with C, L, Pi, T and double T configurations with MIL-F-15733 and MIL-F-28861 QPL filters available... **LP27-LP42**

Value Added Assemblies offer flexible solutions by allowing you to add connectors, modify terminations or add wire harnesses, thereby lowering your cost of acquisition and assembly, reducing your production time/costs and inventory, all while giving you a filter assembly that meets your unique design challenges... **LP43**

- Wide range of package sizes, mounting options and circuit configurations offering maximum design flexibility
- Develop custom application-specific solutions addressing your mechanical and electrical requirements
- High reliability construction... built in accordance to MIL-PRF-15733 or MIL-PRF-28861
- Over 800 standard QPL products and DSCC part numbers
- Effective filtering up to 18 GHz
- Reliability testing available for customer specific requirements

For complete specs and drawings, visit eis.apitech.com/low_pass_filters.asp



Motor Line Feed-Through (MLFT) Filters (Patent Pending)

As the world leader in EMC, API Technologies' Spectrum Control brand has developed a family of high capacitance filters specifically designed for DC motor and other lower voltage applications. The Motor Line Feed-Through (MLFT) filter is a one-component solution that eliminates the need for multiple capacitors, inductive coils, leads and PCB assemblies requiring numerous electrical connections and large amounts of space. MLFT filters (patent pending) are engineered to provide the required EMI filtering and mechanical interface at a reduced cost.

MLFT filters offer significant insertion loss to pass global conductive and radiated EMC tests, such as CISPR 25. Our standard line of filters can be designed into mechanical packages for easy retrofit into existing designs or as custom assemblies to simplify installation during production. These filters are available in stamped or threaded housings, with single or dual lines, and round leads or Faston terminals for applications to 100 volts.

Benefits

- Easy installation, provides a connector interface
- Excellent EMI filtering through GHz range
- Competitive cost
- Space saving EMI solution
- Fewer electrical connections
- Failsafe DC open circuit for safety concerns
- Standard and custom filtering and mechanical packages
- Transient voltage and surge protection available

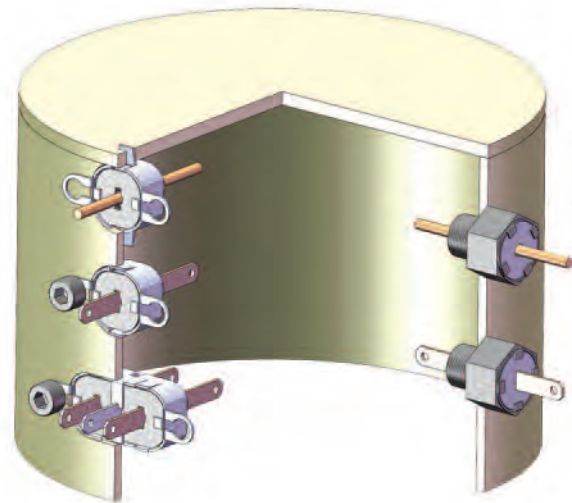

Ordering Information

Example: **MLFT2-001-T F CA C**

The part number shown represents a single line, threaded MLFT Filter with Faston Terminals, a capacitance rating of 0.20 μF and a voltage rating of 100V.

| | | | | | | | |
|---------------------------------------|---|--|---|--|----------|--|-----------------------|
| MLFT2 | - | 001 | - | T | F | CA | C |
| | | | | | | | |
| Motor Line Feed-Through Filter | | Style | | Terminal | | Capacitance | Voltage Rating |
| | | T = Single line threaded S = Single line stamped D = Dual line stamped | | F = .110 Faston R = .062 round lead | | CA = .20 μF CC = 2000 pF CD = 20 pF | C = 100V |

Solder-in Filters



Solder-in filters are ideal for use in critical areas where space does not allow use of mounting tools or hardware. The solder-in feature also allows installation in unison with other board mounted components. Primarily used in filtering signal/data lines and DC power lines.

Features

- Small size to allow effective use of space
- Voltage ratings to 750 VDC
- Multiple circuit configurations: C, L & Pi available
- High temperature construction to prevent reflow during installation
- MIL-F-15733 QPL versions available

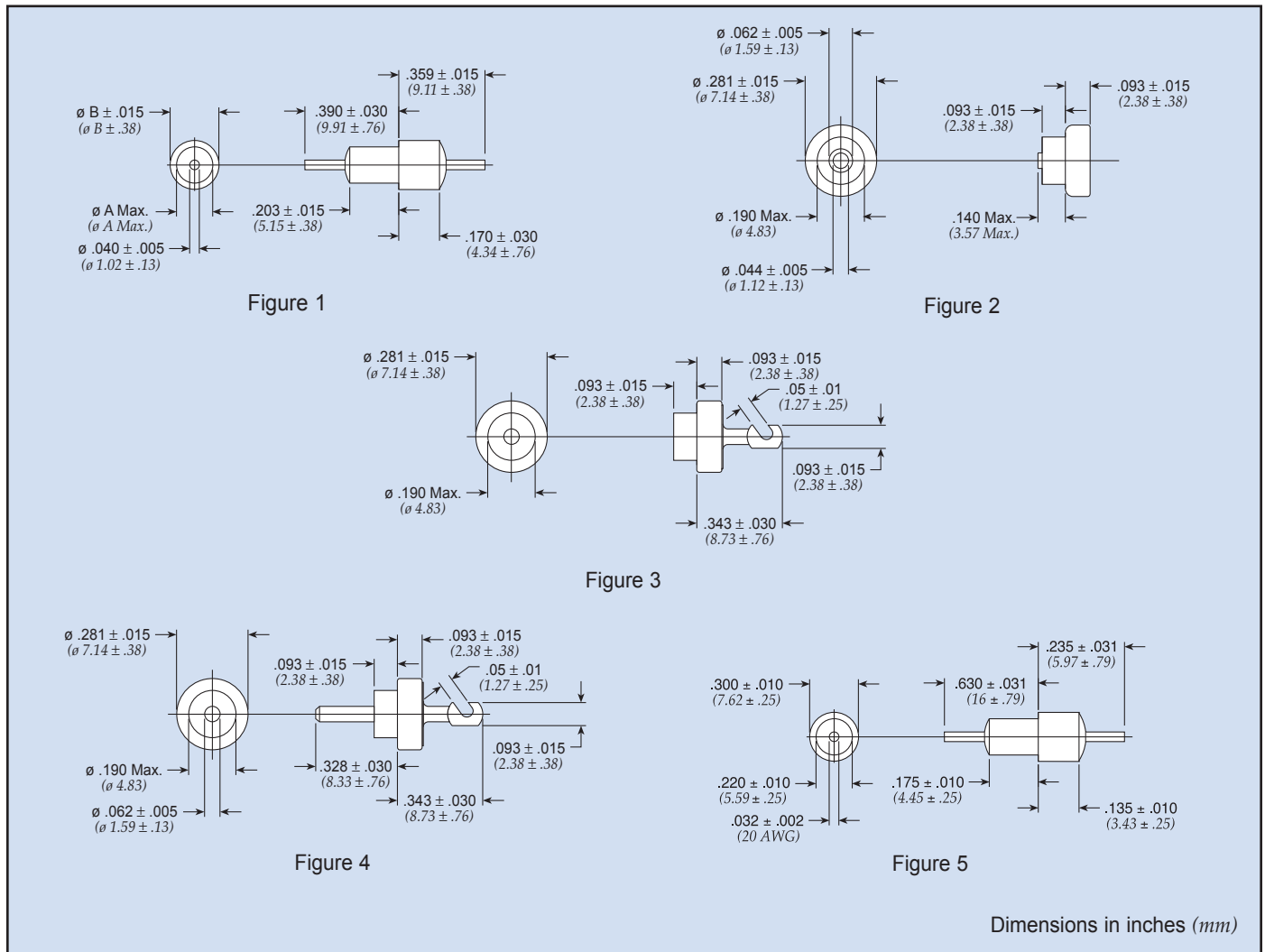

Solder-in Filters

Solder-in C Circuit

| Part Number | See Pg. LP3 for Fig. | A | | B | | Rated Voltage 125°C DC | I Amp | Cap* | Minimum Insertion Loss (dB) | | | | | | |
|-------------------|----------------------|-------|--------|-------|--------|------------------------|-------|--------------------|-----------------------------|--------|--------|---------|---------|-------|--------|
| | | In | (mm) | In | (mm) | | | | 1 MHz | 10 MHz | 30 MHz | 100 MHz | 300 MHz | 1 GHz | 10 GHz |
| 54-786-003 | 1 | 0.156 | (3.96) | 0.203 | (5.16) | 50 | 10 | 0.30 μ F | 32 | 47 | 54 | 60 | 66 | 70 | 70 |
| 54-785-002 | 1 | 0.125 | (3.18) | 0.184 | (4.67) | 100 | 10 | 0.05 μ F (min) | 16 | 33 | 41 | 45 | 48 | 50 | 50 |
| 54794002X5R101M | 4 | — | — | — | — | 250 | 25 | 100 pF \pm 20% | — | — | — | — | 10 | 20 | 20 |
| 54803004X5R101M | 3 | — | — | — | — | 250 | 25 | 100 pF \pm 20% | — | — | — | — | 10 | 20 | 20 |
| 54802002X5R101M | 2 | — | — | — | — | 250 | 25 | 100 pF \pm 20% | — | — | — | — | 10 | 20 | 20 |
| † 54794002X5R471M | 4 | — | — | — | — | 250 | 25 | 470 pF \pm 20% | — | — | — | 12 | 22 | 25 | 25 |
| † 54803004X5R471M | 3 | — | — | — | — | 250 | 25 | 470 pF \pm 20% | — | — | — | 12 | 22 | 25 | 25 |
| 54802002X5R471M | 2 | — | — | — | — | 250 | 25 | 470 pF \pm 20% | — | — | — | 12 | 22 | 25 | 25 |
| † 54802002X5V102P | 2 | — | — | — | — | 250 | 25 | 1000 pF | — | — | — | 15 | 25 | 35 | 40 |
| † 54803004X5V102P | 3 | — | — | — | — | 250 | 25 | 1000 pF | — | — | — | 15 | 25 | 35 | 40 |
| † 54794002X5V102P | 4 | — | — | — | — | 250 | 25 | 1000 pF | — | — | — | 15 | 25 | 35 | 40 |
| † 54-786-077 | 5 | — | — | — | — | 750 | 10 | 1000pF | — | 4 | — | 20 | 25 | 35 | 40 |

† Also available through API's authorized distributors.

* Tolerances are +100/-0% unless noted.

Solder-in Filters

Solder-in Pi Circuit

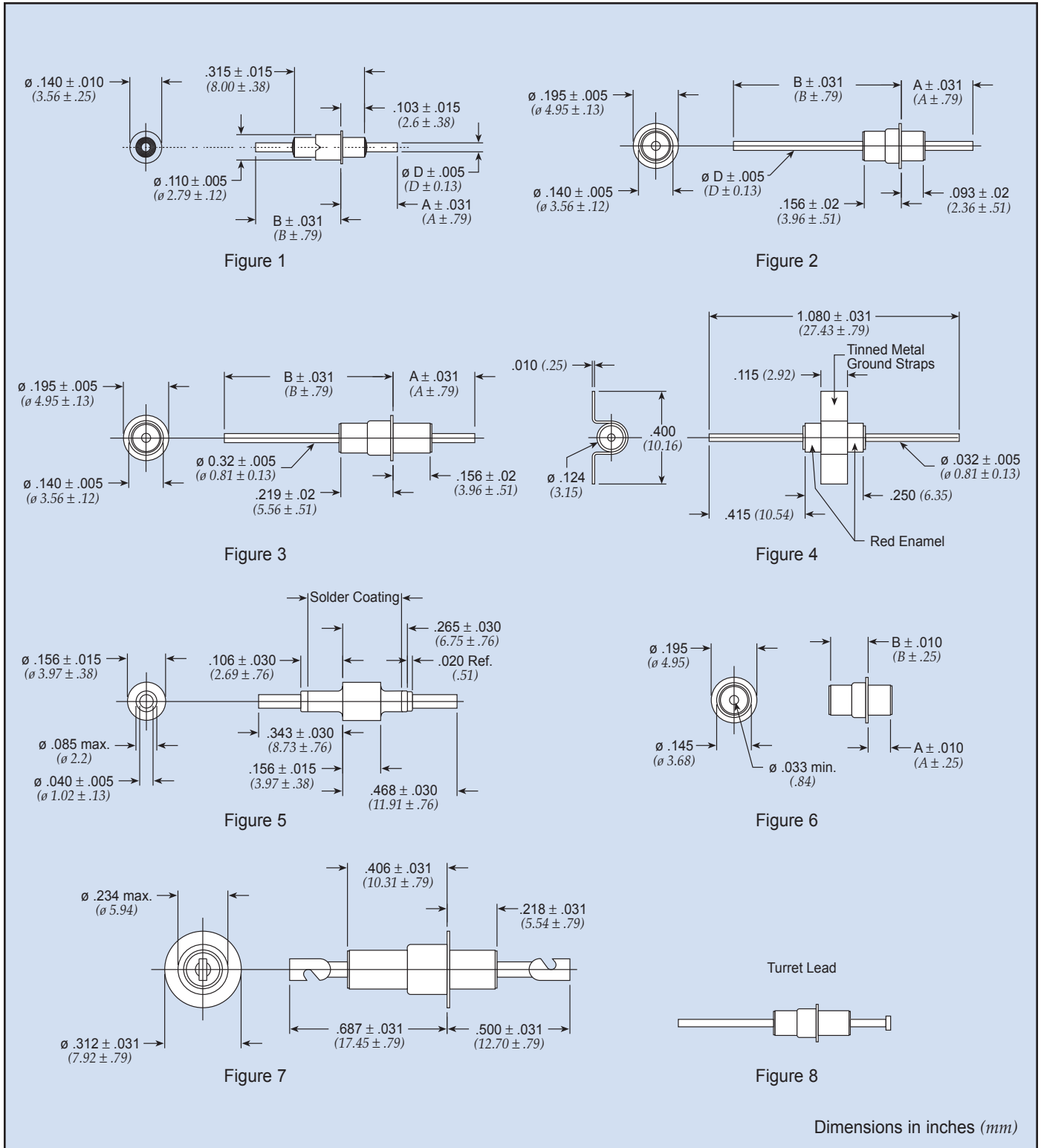

Solder-in Filters

Solder-in Pi Circuit

| Part Number | M15733 MIL Number | See Pg. LP5 for Fig. | A | | B | | D | | Rated Voltage 125°C | | I Amp | Min Cap | Minimum Insertion Loss (dB) | | | | | | |
|---------------|-------------------|----------------------|-------------|----------|-------|---------|--------|--------|---------------------|-------|-------|----------|-----------------------------|--------|--------|---------|---------|-------|--------|
| | | | In | (mm) | In | (mm) | In | (mm) | DC | AC | | | 1 MHz | 10 MHz | 30 MHz | 100 MHz | 300 MHz | 1 GHz | 10 GHz |
| | | | 51-703-013* | /62-0003 | 3 | 0.312 | (7.92) | 0.469 | (11.91) | 0.032 | | | (0.81) | 70 | — | 10 | 1500 pF | — | 5 |
| 51-750-309* | /62-0004 | 2 | 0.268 | (6.81) | 0.780 | (19.81) | 0.032 | (0.81) | 70 | — | 10 | 0.012 µF | 5 | 22 | 50 | 70 | 70 | 65 | 65 |
| † 1234-000* € | — | 2 | 0.257 | (6.53) | 0.780 | (19.81) | 0.032 | (0.81) | 70 | — | 10 | 0.012 µF | 5 | 25 | 50 | 70 | 70 | 70 | 70 |
| 51-749-304 | — | 4 | — | — | — | — | — | — | 70 | — | 10 | 0.012 µF | 5 | 25 | 50 | 70 | 70 | 65 | 65 |
| 1234-001 | — | 4 | — | — | — | — | — | — | 70 | — | 10 | 0.012 µF | 5 | 25 | 50 | 70 | 70 | 65 | 65 |
| † 51-750-301* | — | 2 | 0.250 | (6.35) | 0.780 | (19.81) | 0.032 | (0.81) | 70 | — | 10 | 0.012 µF | 5 | 25 | 50 | 70 | 70 | 70 | 70 |
| † 1233-000* € | — | 3 | 0.312 | (7.92) | 0.780 | (19.81) | 0.032 | (0.81) | 70 | — | 10 | 0.022 µF | 7 | 35 | 60 | 70 | 70 | 70 | 70 |
| † 51-750-302* | — | 3 | 0.312 | (7.92) | 0.780 | (19.81) | 0.032 | (0.81) | 70 | — | 10 | 0.022 µF | 7 | 25 | 60 | 70 | 70 | 70 | 70 |
| 51-750-313 | /51-0002 | 3 | 0.312 | (7.92) | 0.780 | (19.81) | 0.032 | (0.81) | 70 | — | 10 | 0.022 µF | 7 | 25 | 60 | 70 | 70 | 70 | 70 |
| † 51-723-303 | — | 5 | — | — | — | — | — | — | 200 | — | 10 | 1300 pF | — | 5 | 15 | 30 | 45 | 55 | 55 |
| 51-713-010 | /62-0002 | 1 | 1.140 | (28.96) | 1.277 | (32.44) | 0.032 | (0.81) | 200 | — | 10 | 1500 pF | — | 5 | 12 | 45 | 50 | 70 | 70 |
| † 1251-001 € | — | 1 | 1.109 | (28.17) | 1.206 | (30.63) | 0.032 | (0.81) | 200 | — | 10 | 1500 pF | — | 5 | 15 | 40 | 50 | 70 | 70 |
| 51-703-001* | — | 3 | 0.312 | (7.92) | 0.406 | (10.31) | 0.032 | (0.81) | 200 | — | 10 | 1500 pF | — | 8 | 17 | 45 | 65 | 70 | 70 |
| † 1203-050 € | — | 3 | 0.312 | (7.92) | 0.406 | (10.31) | 0.032 | (0.81) | 200 | — | 10 | 1500 pF | — | 5 | 15 | 45 | 50 | 70 | 70 |
| 51-703-012* | /62-0001 | 3 | 0.312 | (7.92) | 0.406 | (10.31) | 0.032 | (0.81) | 200 | 140 | 10 | 1500 pF | — | 3 | 15 | 45 | 50 | 70 | 70 |
| 51-713-002 | — | 1 | 1.103 | (28.01) | 1.212 | (30.78) | 0.032 | (0.81) | 200 | — | 10 | 1500 pF | — | 5 | 12 | 40 | 70 | 70 | 70 |
| 1214-029 | — | 2 | 0.288 | (7.31) | 0.780 | (19.81) | 0.032 | (0.81) | 200 | — | 10 | 1750 pF | — | 5 | 15 | 50 | 60 | 60 | 70 |
| † 1214-007 € | — | 6 | 0.093 | (2.36) | 0.157 | (3.99) | — | — | 200 | — | 10 | 1750 pF | — | 5 | 15 | 35 | 50 | 60 | 60 |
| 51-707-002* | — | 2 | 0.288 | (7.31) | 0.780 | (19.81) | 0.032 | (0.81) | 200 | — | 10 | 1750 pF | — | 8 | 17 | 50 | 65 | 70 | 70 |
| † 1214-001* | — | 2 | 0.288 | (7.31) | 0.780 | (19.81) | 0.032 | (0.81) | 200 | — | 10 | 1750 pF | — | 5 | 15 | 50 | 50 | 60 | 60 |
| † 51-707-006* | /33-0001 | 2 | 0.288 | (7.31) | 0.780 | (19.81) | 0.032 | (0.81) | 200 | 90 | 10 | 1750 pF | — | 5 | 15 | 50 | 50 | 60 | 60 |
| 51-707-007 | /33-0002 | 2 | 0.288 | (7.31) | 0.780 | (19.81) | 0.032 | (0.81) | 200 | 90 | 10 | 1750 pF | — | 5 | 15 | 50 | 50 | 60 | 60 |
| 51-707-026 | /66-0001 | 6 | 0.288 | (7.31) | 0.157 | (3.99) | — | — | 200 | — | 10 | 1750 pF | — | 5 | 15 | 35 | 50 | 50 | 50 |
| † 51-750-322 | — | 2 | 1.123 | (28.52) | 1.347 | (34.21) | 0.040 | (1.02) | 200 | — | 10 | 3000 pF | — | 7 | 25 | 50 | 65 | 65 | 65 |
| 51-703-007* | /51-0001 | 3 | 0.312 | (7.92) | 0.406 | (10.31) | 0.032 | (0.81) | 200 | 200 | 10 | 5500 pF | — | 15 | 30 | 55 | 65 | 70 | 70 |
| 1223-012 | — | 1 | 0.240 | (6.10) | 0.360 | (9.14) | 0.040 | (1.02) | 200 | — | 15 | 3000 pF | — | 7 | 25 | 50 | 65 | 65 | 65 |
| † 1204-050 € | — | 7 | 0.210 | (5.34) | — | — | — | — | 500 | — | 25 | 3000 pF | — | 8 | 25 | 50 | 65 | 70 | 70 |
| 51-704-002 | /40-0001 | 7 | 0.234 | (5.94) | — | — | — | — | 500 | 350 | 25 | 3000 pF | — | 7 | 25 | 55 | 65 | 70 | 70 |

* Denotes parts with turret on one end per Figure 8.
 † Also available through API's authorized distributors.
 € Also available through API's authorized European distributors/agents.



Large Diameter Solder-in High Temp Filters

Features

- .400" diameter mounting vs .128" diameter mounting
- High temperature construction withstands 300°C installation temperatures
- Increased capacitance values than standard 9900 series - up to 1.2uF
- EMI filtering from 500KHz up to 10GHz
- 15 Amp current rating
- Ideal for low to medium impedance circuits where large amounts of capacitance to ground can be tolerated (feed-thru "C" circuit)
- Glass seal one end provides protection from hostile environments and maintain hermeticity
- Rugged monolithic discoidal capacitor construction
- Gold plated suited for gold bonding
- Designed to be soldered into a package, bracket or bulkhead
- Reverse seal available
- Special lead length and end terminations available

Large Diameter Solder-in High Temp Filters

| Part Number | Circuit | AMP | DC Voltage | Min Cap (µf) | Minimum Insertion Loss (dB) | | | | | |
|-----------------|---------|-----|------------|--------------|-----------------------------|-------|--------|---------|-------|--------|
| | | | | | 500 KHz | 1 MHz | 10 MHz | 100 MHz | 1 GHz | 10 GHz |
| SCI-9945-125H | C | 15 | 50 | 1.2 | 33 | 37 | 52 | 70 | 70 | 70 |
| SCI-9945-504H | C | 15 | 100 | .50 | 26 | 34 | 42 | 58 | 70 | 70 |
| SCI-9945-754H | C | 15 | 100 | .75 | 31 | 37 | 43 | 62 | 70 | 70 |
| SCI-9945-105H | C | 15 | 100 | 1.0 | 31 | 40 | 48 | 64 | 70 | 70 |
| SCI-9945-503HAC | C | 15 | 200* | .050 | 7 | 15 | 34 | 42 | 70 | 70 |
| SCI-9945-154HAC | C | 15 | 200* | .15 | 17 | 24 | 38 | 50 | 70 | 70 |
| SCI-9945-103H | C | 15 | 400 | .010 | — | 4 | 20 | 34 | 50 | 60 |
| SCI-9945-503H | C | 15 | 400 | .050 | 7 | 15 | 34 | 44 | 70 | 70 |

* Rated 200VDC or 125VAC/400Hz

Miniature Solder-in Filters 9900 Series

These filters are ideal for microwave applications such as attenuators and oscillators, and perform well in high impedance circuits where large capacitance values are not practical.

Features

- Miniature size to allow effective use of space
- Standard capacitance values from 5pF to .033μF
- Voltage ratings to 200 VDC/115 VAC 0–400 Hz
- Hermetically sealed on one end allows for through-hole sealing between compartments
- High temperature construction meets MIL-F-28861 solderability and resistance to soldering heat requirements
- Available in MIL-C-11015 versions — see page CF10
- Gold plating compatible with gold bonding techniques

Marking C Circuit

Color dot standard as follows:

- | | |
|-----------------------|-----------------------|
| ● 101 Green – 100pF | ● 272 Red – 2700pF |
| ● 501 Brown – 500pF | ● 502 Blue – 5000pF |
| ● 102 Purple – 1000pF | ● 153 Pink – 15000pF |
| ● 122 White – 1200pF | ● 000 None – 10pF max |

Marking L Circuit

Color dot standard as follows:

- | | |
|-----------------------|-----------------------|
| ● 100 Violet – 10pF | ● 103 2White – .01μF |
| ● 250 Blue – 25pF | ● 153 2White – .015μF |
| ● 102 White – 1000pF | ● 273 2Red – 27000pF |
| ● 152 White – 1500pF | ● 333 2Red – .033μF |
| ● 502 Yellow – 5000pF | |

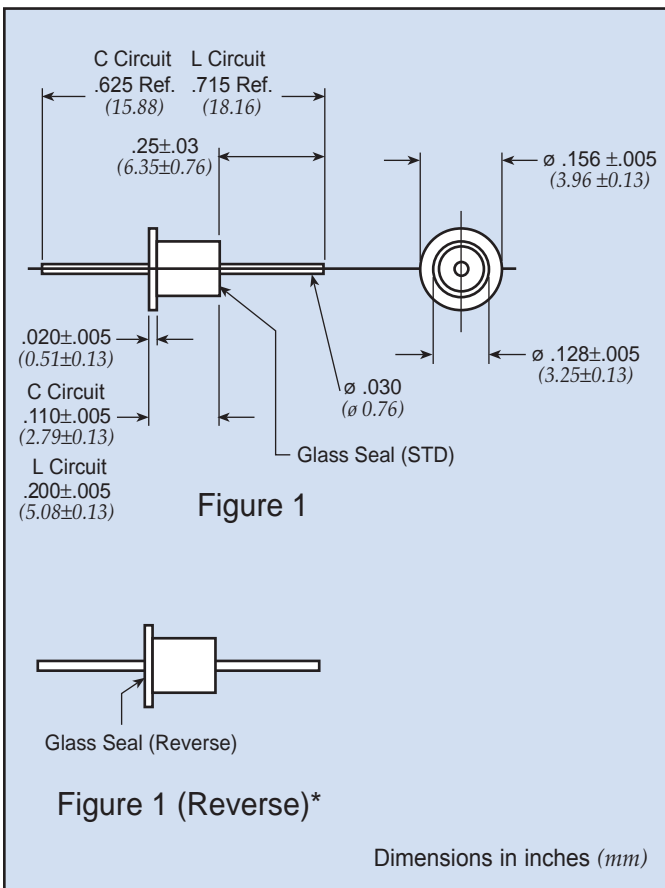

Miniature Solder-in Filters 9900 Series

Miniature Solder-in C Circuit

| Part Number* | Figure | Rated Voltage 125°C | | I Amp | Min Cap | Minimum Insertion Loss (dB) | | | | | | |
|----------------|--------|------------------------|-----|----------|------------|-----------------------------|-----------|-----------|------------|------------|----------|-----------|
| | | DC | AC | | | 1 MHz | 10 MHz | 30 MHz | 100 MHz | 300 MHz | 1 GHz | 10 GHz |
| SCI-9900-153 | 1 | 50 | | 5 | 0.015 µF | 7 | 25 | 30 | 40 | 40 | 60 | 60 |
| SCI-9900-303 | 1 | 50 | | 5 | 0.030 µF | 10 | 30 | 35 | 45 | 50 | 55 | 55 |
| † SCI-9910-272 | 1 | 100 | | 5 | 2700 pF | — | 10 | 18 | 25 | 33 | 40 | 50 |
| † SCI-9910-502 | 1 | 100 | | 5 | 5000 pF | — | 15 | 20 | 30 | 35 | 45 | 55 |
| SCI-9900-000 | 1 | 200 | | 5 | 4 pF max. | — | — | — | — | — | 10 | 10 |
| † SCI-9920-101 | 1 | 200 | 115 | 5 | 100 pF | — | — | — | 3 | 10 | 20 | 28 |
| † SCI-9920-501 | 1 | 200 | 115 | 5 | 500 pF | — | — | — | 15 | 22 | 35 | 40 |
| † SCI-9920-122 | 1 | 200 | 115 | 5 | 1200 pF | — | 5 | 10 | 20 | 28 | 35 | 45 |

* For reverse glass seal add an "R" to the end of the part number (SCI-9900-153R).

† Also available through API's authorized distributors.

Parts are RoHS Compliant

Miniature Solder-in L Circuit

| Part Number* | Figure | Rated Voltage 125°C | | I Amp | Min Cap | Minimum Insertion Loss (dB) | | | | |
|--------------|--------|------------------------|----|----------|------------|-----------------------------|-----------|------------|----------|-----------|
| | | DC | AC | | | 1 MHz | 10 MHz | 100 MHz | 1 GHz | 10 GHz |
| SCI-9980-100 | 1 | 200 | | 10 | 10 pF | — | — | — | 7 | 20 |
| SCI-9980-101 | 1 | 200 | | 10 | 100 pF | — | — | 5 | 22 | 35 |
| SCI-9980-102 | 1 | 200 | | 10 | 1000 pF | — | 8 | 25 | 40 | 42 |
| SCI-9980-103 | 1 | 200 | | 10 | .01 µF | 8 | 27 | 48 | 65 | 65 |
| SCI-9980-122 | 1 | 200 | | 10 | 1200 pF | — | 8 | 28 | 42 | 50 |
| SCI-9980-152 | 1 | 200 | | 10 | 1500 pF | — | 10 | 28 | 43 | 53 |
| SCI-9980-153 | 1 | 200 | | 10 | .015 µF | 10 | 28 | 50 | 65 | 65 |
| SCI-9980-250 | 1 | 200 | | 10 | 25 pF | — | — | — | 13 | 25 |
| SCI-9980-272 | 1 | 200 | | 10 | 2700 pF | 8 | 13 | 32 | 45 | 55 |
| SCI-9980-273 | 1 | 50 | | 10 | 27,000 pF | 13 | 33 | 53 | 75 | 75 |
| SCI-9980-333 | 1 | 200 | | 10 | .033 µF | 13 | 35 | 55 | 75 | 75 |
| SCI-9980-501 | 1 | 200 | | 10 | 500 pF | — | — | 18 | 37 | 38 |
| SCI-9980-502 | 1 | 200 | | 10 | 5000 pF | 8 | 17 | 35 | 47 | 55 |

* Reverse seal available. Add R at the end of the part number. (SCI-9980-102R).

Note: Hi-rel versions available. Add R after the first dash. (SCI-R9980-102).

Lt circuit part number series SCI-9981-XXX.

Parts are RoHS Compliant

Spec Mini Solder-in Feed-Thru Filters

API Technologies miniature solder-in filters are hermetically sealed on one end for thru-hole sealing between compartments allowing it to be soldered into a package, bracket, or bulkhead while maintaining hermetically. These mini EMI filters are ideal for a variety of products intended for use in the microwave frequency spectrum including oscillators, attenuators, and synthesizers. The high temperature construction meets military requirements for solderability and resistance to soldering heat and its high-purity gold plating provides excellent compatibility with gold bonding techniques.

Features

- .120" diameter mounting
- Capacitance values from 5pF to .027μF
- RoHS compliant
- Reverse seal available
- High temperature construction

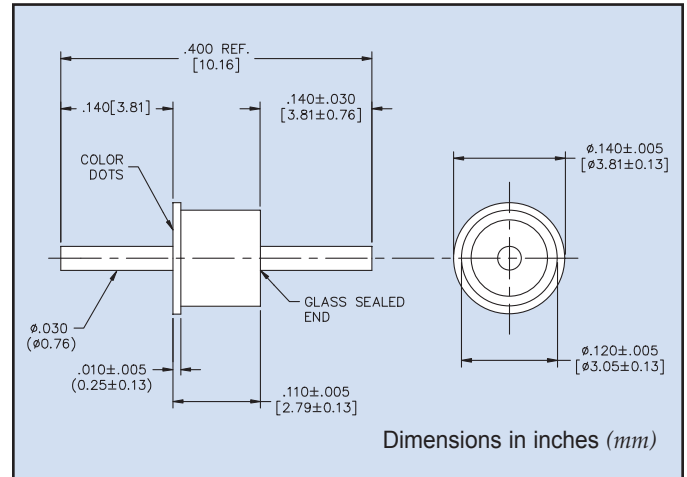

| Part Number | DC Amps | Working Voltage | Cap (μf) | Minimum Insertion Loss (dB) | | | | | |
|--------------|---------|-----------------|----------|-----------------------------|-------|--------|---------|-------|--------|
| | | | | 500 KHz | 1 MHz | 10 MHz | 100 MHz | 1 GHz | 10 GHz |
| SCI-9909-008 | 5 | 200 | 5 | — | — | — | — | — | 5 |
| SCI-9909-009 | 5 | 200 | 10 | — | — | — | — | 5 | 20 |
| SCI-9909-010 | 5 | 200 | 25 | — | — | — | — | 10 | 25 |
| SCI-9909-011 | 5 | 200 | 50 | — | — | — | — | 10 | 25 |
| SCI-9909-012 | 5 | 200 | 100 | — | — | — | 3 | 20 | 28 |
| SCI-9909-013 | 5 | 200 | 250 | — | — | — | 5 | 22 | 30 |
| SCI-9909-014 | 5 | 200 | 500 | — | — | — | 15 | 35 | 40 |
| SCI-9909-015 | 5 | 200 | 1000 | — | — | 5 | 20 | 35 | 45 |
| SCI-9909-016 | 5 | 200 | 1500 | — | — | 5 | 22 | 35 | 45 |
| SCI-9909-017 | 5 | 100 | 2700 | — | — | 10 | 25 | 40 | 50 |
| SCI-9909-018 | 5 | 100 | 5000 | — | — | 15 | 30 | 45 | 55 |
| SCI-9909-019 | 5 | 50 | 10,000 | — | 4 | 21 | 35 | 50 | 60 |
| SCI-9909-020 | 5 | 50 | 27,000 | — | 10 | 28 | 42 | 55 | 65 |

Spec Mini-Press 9900 Series

This new knurled filter is designed to be pressed into place and create a reliable mechanical bond. This feature makes it an excellent selection for applications where soldering is undesirable. Suitable plating is available that allows gold bonding to the terminals.

Applications

These filters are ideal for microwave and RF applications such as attenuators, synthesizers, and oscillators. They perform well in high impedance circuits where large capacitance values are not practical.

Installation

- .136" to .137" (3.45-3.48mm) diameter hole
- Hole must be free of all insulating materials.
- Installation tool must have a hole of sufficient depth and diameter to accept the terminal of the filter.
- Installation force must be applied gradually and smoothly until the flange of the filter is seated against the receiving part (request installation instructions).

Mechanical Specifications

- Installation* Press-in
- Plating* Gold
- Seal* Glass sealed on one end,
resin sealed on the other end
- Termination Options* Plating suitable for gold bonding
- Operating Temperature* -55°C to +125°C

Circuit Schematic

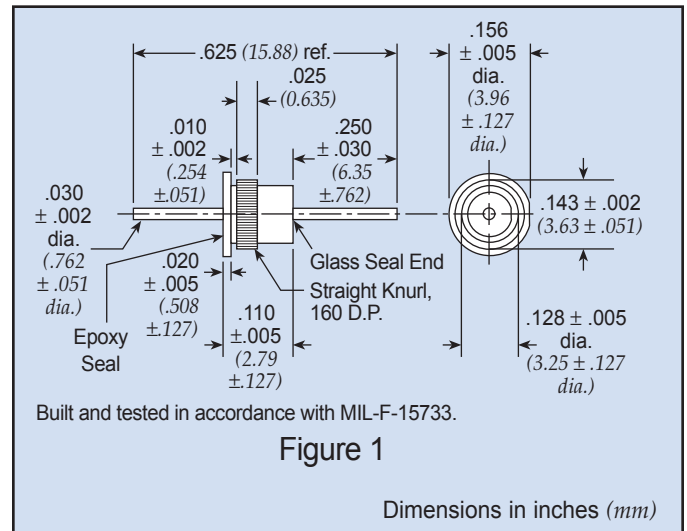
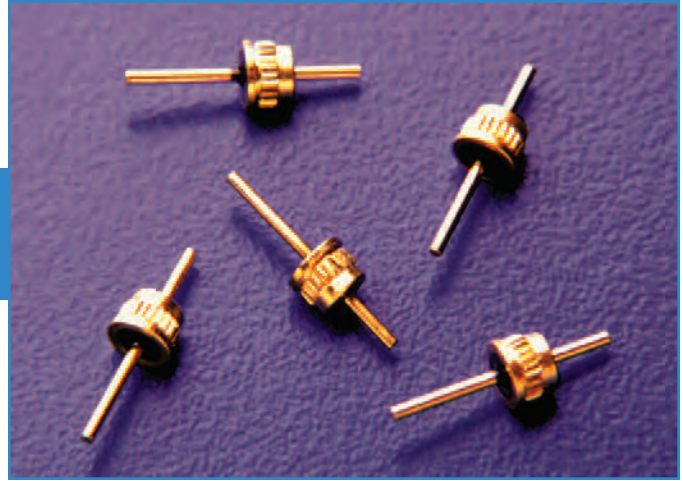
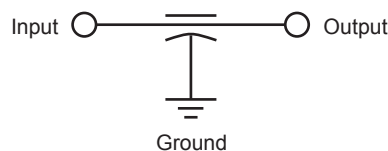

Insertion Tool

Part Number: SCI-9925-200

| Part Number | Figure | Rated Voltage 125°C | | Cap | Minimum Insertion Loss (dB) | | | | | | |
|----------------|--------|------------------------|----------|--------------------|-----------------------------|-----------|-----------|------------|------------|----------|-----------|
| | | DC | I Amp | | 1 MHz | 10 MHz | 30 MHz | 100 MHz | 300 MHz | 1 GHz | 10 GHz |
| † SCI-9925-153 | 1 | 50 | 5 | 0.015 µF +100%/-0% | 7 | 25 | 30 | 40 | 40 | 60 | 60 |
| † SCI-9925-303 | 1 | 50 | 5 | 0.030 µF +100%/-0% | 10 | 30 | 35 | 45 | 50 | 55 | 55 |
| † SCI-9925-502 | 1 | 100 | 5 | 5000 pF +100%/-0% | — | 15 | 20 | 30 | 35 | 45 | 55 |
| † SCI-9925-000 | 1 | 200 | 5 | 10 pF max. | — | — | — | — | — | 10 | 10 |
| † SCI-9925-101 | 1 | 200 | 5 | 100 pF +100%/-0% | — | — | — | 3 | 10 | 20 | 28 |
| † SCI-9925-501 | 1 | 200 | 5 | 500 pF +100%/-0% | — | — | — | 15 | 22 | 35 | 40 |
| † SCI-9925-122 | 1 | 200 | 5 | 1200 pF +100%/-0% | — | 5 | 10 | 20 | 28 | 35 | 45 |
| SCI-9925-272 | 1 | 200 | 5 | 2700 pF +100%/-0% | — | 10 | 18 | 25 | 33 | 40 | 50 |

† Also available through API's authorized distributors.
Note: Parts are RoHS Compliant

Spec Spin Filters



API Technologies' Spectrum Control brand introduces the new space saving #2-56 threaded miniature EMI spanner filter. This new threaded filter is designed without a hex and does not require soldering for installation. These features make it an excellent selection for applications that require many lines to be filtered in close proximity. The easy swap out also allows for flexibility in filter replacement and capacitance substitution. Easy filter substitution also allows for flexibility in filter placement. Custom design queries are always welcome.

Applications

API's Spectrum Control brand spanner filter offers superior insertion loss over a broad frequency range when compared to surface mount components. The filter is available in capacitance values up to 10,000 pF, and is featured in a microcircuit package used in microwave applications such as frequency synthesizers, power amplifiers, MMW radio, and is ideal for commercial and high-reliability applications.

Electrical Specifications

Operating Temperature -55°C to +125°C

Voltage Rating 50 VDC

Current Rating 5 A

Effective Filtering From 1 MHz to 10 GHz

Capacitance to 10,000 pF

Dielectric Withstanding

Voltage 125 VDC

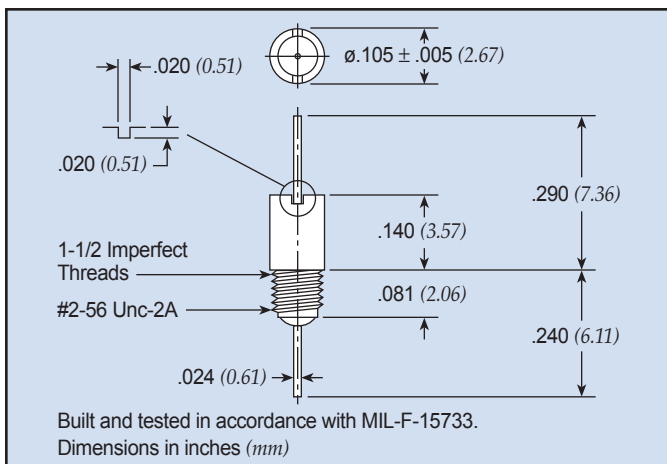

Mechanical Specifications

Center Spacing0110"

Lead Finish Gold

Bushing Finish Gold

Tightening Torque 14 oz-in (± 2)
(0.11Nm)

Insertion Tool

Part Number: 54-874-020

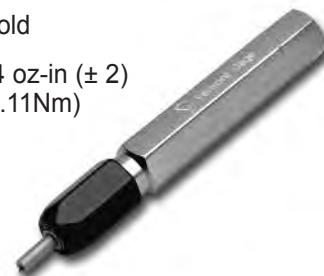

| Part Number* | Cap (pF) | Max. Tolerance | Circuit | Current | Voltage | DWV | I.R. | Temperature Range |
|--------------|----------|----------------|---------|---------|---------|---------|----------|-------------------|
| 54-874-010 | 10 | +0%/-20% | C | 5 A | 50 VDC | 125 VDC | 1,000 MΩ | -55°C to +125°C |
| 54-874-011 | 39 | +50%/-20% | | | | | | |
| 54-874-012 | 100 | | | | | | | |
| 54-874-013 | 390 | | | | | | | |
| 54-874-014 | 1,000 | | | | | | | |
| 54-874-015 | 2,000 | +100%/-0% | | | | | | |
| 54-874-016 | 3,300 | | | | | | | |
| 54-874-017 | 4,700 | | | | | | | |
| 54-874-018 | 10,000 | +80%/-20% | | | | | | |

Note: Parts are RoHS Compliant

Resin Sealed Bolt-in Filters

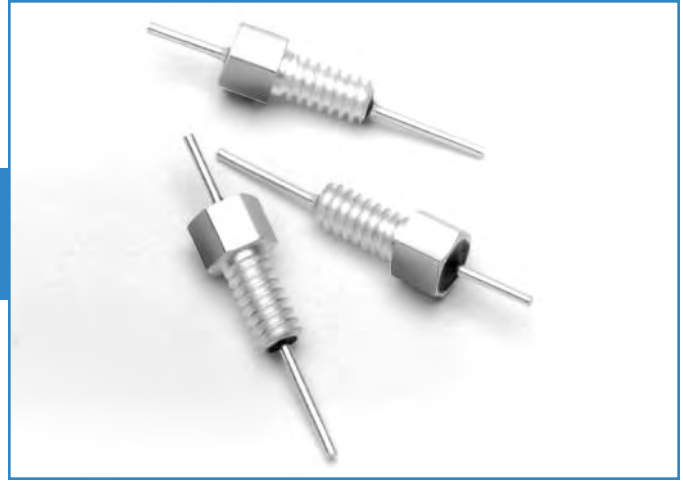

These filters are easily mounted in a tapped hole or through-hole with supplied nut and lock-washer. The rugged case with resin seals at both ends provides excellent environmental protection. Primarily used in filtering signal/data lines and DC power lines.

Features

- Wide range of sizes: 4-40 thread through 5/16-24 thread
- Voltage ratings to 500 VDC/220 VAC (400 Hz)
- MIL-F-15733 QPL filters available
- Multiple circuit configurations: C, L and Pi
- Metric threaded filters available, consult factory

4-40 C Circuit

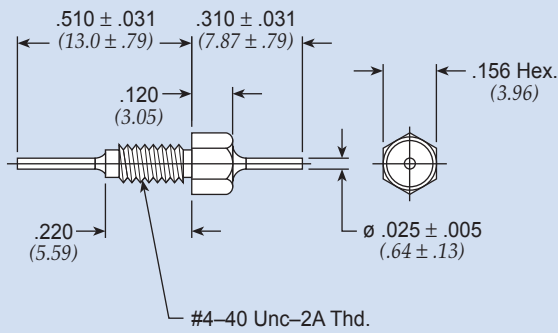

Figure 1

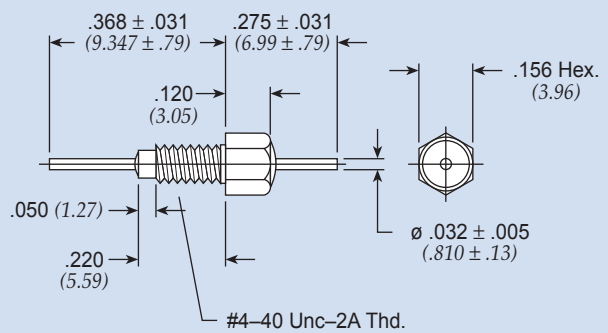

Figure 2

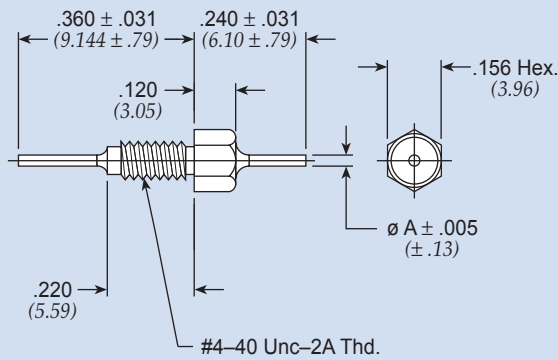

Figure 3

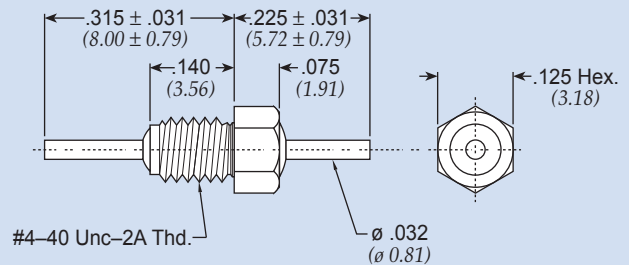

Figure 4

Dimensions in inches (mm)

Resin Sealed Bolt-in Filters

4-40 C Circuit

| Part Number | See Pg. LP12 for Fig. | Rated Voltage 125°C | | I Amp | Min Cap | A | | Minimum Insertion Loss (dB) | | | | | | | |
|-------------------|-----------------------|---------------------|-----|-------|--------------|-------|---------|-----------------------------|-------|--------|--------|---------|---------|-------|--------|
| | | DC | AC | | | In | (mm) | 1 MHz | 3 MHz | 10 MHz | 30 MHz | 100 MHz | 300 MHz | 1 GHz | 10 GHz |
| † SCI-9110-100 | 3 | 50 | — | 10 | 10 pF | 0.032 | (0.81) | — | — | — | — | — | — | 10 | 10 |
| † 9900-381-6004 | 2 | 50 | — | 10 | 5000 pF | — | — | — | — | 15 | 22 | 30 | 35 | 45 | 55 |
| 9900-381-6026 | 2 | 50 | — | 10 | 0.031 µF | — | — | 12 | 20 | 25 | 35 | 40 | 45 | 55 | 60 |
| † 9900-381-6006 | 2 | 50 | — | 10 | 0.045 µF | — | — | 14 | 22 | 30 | 40 | 45 | 50 | 55 | 60 |
| † 54-790-023 | 1 | 100 | — | 10 | 0.050 µF | — | — | 15 | 24 | 34 | 41 | 45 | 50 | 60 | 60 |
| † 54790001X5F101M | 1 | 100 | — | 10 | 100 pF ± 20% | — | — | — | — | — | — | — | 10 | 20 | 25 |
| 54-790-019 | 1 | 100 | — | 10 | 2700 pF | — | — | — | — | 9 | 18 | 27 | 33 | 35 | 35 |
| 9900-381-6013 | 2 | 100 | — | 10 | 2700 pF | — | — | — | — | 10 | 18 | 25 | 33 | 40 | 50 |
| 54-790-020 | 1 | 100 | — | 10 | 5600 pF | — | — | — | — | 15 | 24 | 33 | 37 | 40 | 40 |
| SCI-9112-273 | 3 | 100 | — | 3 | 0.027 µF | 0.016 | (0.41)* | 10 | 20 | 30 | 37 | 45 | 45 | 55 | 60 |
| SCI-9110-273 | 3 | 100 | — | 10 | 0.027 µF | 0.020 | (0.51) | 10 | 20 | 30 | 37 | 45 | 45 | 55 | 60 |
| 54-790-022 | 1 | 100 | — | 10 | 0.027 µF | — | — | 10 | 20 | 30 | 37 | 45 | 50 | 55 | 60 |
| † SCI-9112-503 | 3 | 100 | — | 3 | 0.05 µF | 0.016 | (0.41)* | 15 | 24 | 35 | 41 | 45 | 50 | 60 | 60 |
| SCI-9110-503 | 3 | 100 | — | 10 | 0.05 µF | 0.020 | (0.51) | 15 | 24 | 35 | 41 | 45 | 50 | 60 | 60 |
| 54-862-001 | 4 | 200 | — | 10 | 10 pF | — | — | — | — | — | — | — | — | 10 | 10 |
| 54-862-002 | 4 | 200 | — | 10 | 100 pF | — | — | — | — | — | — | 3 | 10 | 20 | 28 |
| 54-862-003 | 4 | 200 | — | 10 | 1000 pF | — | — | — | — | — | — | 15 | 25 | 35 | 40 |
| † 9900-381-6020 | 2 | 200 | — | 10 | 100 pF | — | — | — | — | — | — | 3 | 10 | 20 | 28 |
| SCI-9122-101 | 3 | 200 | 115 | 3 | 100 pF | 0.016 | (0.41)* | — | — | — | — | — | 10 | 20 | 20 |
| SCI-9120-101 | 3 | 200 | 115 | 10 | 100 pF | 0.020 | (0.51) | — | — | — | — | — | 10 | 20 | 20 |
| 9900-381-6021 | 2 | 200 | — | 10 | 500 pF | — | — | — | — | — | — | 15 | 20 | 35 | 40 |
| SCI-9122-102 | 3 | 200 | 115 | 3 | 1000 pF | 0.016 | (0.41)* | — | — | — | 11 | 20 | 28 | 28 | 40 |
| SCI-9120-102 | 3 | 200 | 115 | 10 | 1000 pF | 0.020 | (0.51) | — | — | — | 11 | 20 | 28 | 28 | 40 |
| † 9900-381-6022 | 2 | 200 | — | 10 | 1200 pF | — | — | — | — | 5 | 9 | 20 | 28 | 35 | 45 |
| SCI-9122-502 | 3 | 200 | 115 | 3 | 5000 pF | 0.016 | (0.41)* | — | — | 15 | 24 | 33 | 37 | 40 | 50 |
| SCI-9120-502 | 3 | 200 | 115 | 10 | 5000 pF | 0.020 | (0.51) | — | — | 15 | 24 | 33 | 37 | 40 | 50 |
| SCI-9122-103 | 3 | 200 | 115 | 3 | 0.01 µF | 0.016 | (0.41)* | — | 12 | 20 | 29 | 38 | 45 | 50 | 55 |
| SCI-9120-103 | 3 | 200 | 115 | 10 | 0.01 µF | 0.020 | (0.51) | — | 12 | 20 | 29 | 38 | 45 | 50 | 55 |
| 9900-381-6005 | 2 | 200 | — | 10 | 0.015 µF | — | — | 7 | 9 | 20 | 29 | 35 | 45 | 50 | 60 |
| † 54-790-018 | 1 | 300 | — | 10 | 1000 pF | — | — | — | — | — | 9 | 20 | 28 | 28 | 40 |
| † 54-790-021 | 1 | 300 | — | 10 | 0.01 µF | — | — | — | 9 | 20 | 29 | 38 | 45 | 50 | 50 |

* Tinned, steel leads.

† Also available through API's authorized distributors.

Resin Sealed Bolt-in Filters

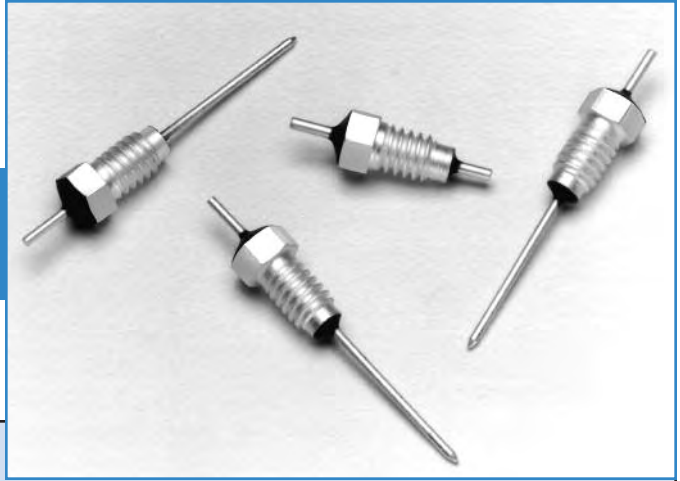

4-40 L and Pi Circuit

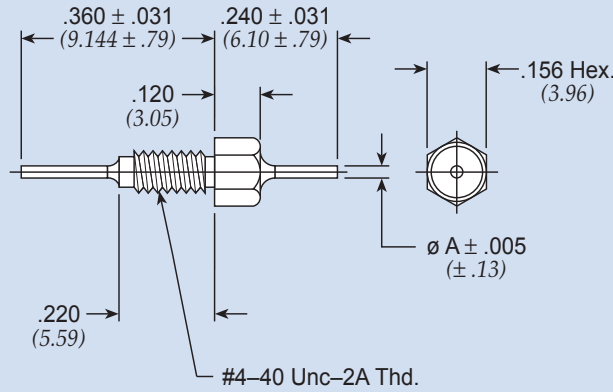

Figure 1

Dimensions in inches (mm)

| Part Number | Figure | Rated Voltage 125°C | | I Amp | CKT | Min Cap | A | | Minimum Insertion Loss (dB) | | | | | | | |
|---------------|--------|------------------------|-----|----------|-----|------------|-------|---------|-----------------------------|----------|-----------|-----------|------------|------------|----------|-----------|
| | | DC | AC | | | | In | (mm) | 1 MHz | 3 MHz | 10 MHz | 30 MHz | 100 MHz | 300 MHz | 1 GHz | 10 GHz |
| +51-729-305 | 1 | 50 | — | 3 | Pi | 5500 pF | 0.018 | (0.46) | — | 7 | 14 | 40 | 60 | 70 | 70 | 70 |
| +51-729-312 | 1 | 50 | — | 3 | Pi | 7000 pF | 0.018 | (0.46) | — | 8 | 15 | 40 | 65 | 70 | 70 | 70 |
| SCI-3102-002 | 1 | 50 | — | 3 | LB | 0.075 μF | 0.016 | (0.41)* | 18 | 25 | 37 | 42 | 52 | 55 | 70 | 70 |
| SCI-3102-000 | 1 | 50 | — | 5 | LB | 0.075 μF | 0.016 | (0.41) | 18 | 25 | 37 | 42 | 52 | 55 | 70 | 70 |
| SCI-3102-007 | 1 | 50 | — | 10 | LB | 0.075 μF | 0.025 | (0.64) | 18 | 25 | 37 | 42 | 52 | 55 | 70 | 70 |
| +51-729-304 | 1 | 100 | — | 3 | LB | 0.022 μF | 0.018 | (0.46) | 7 | 17 | 27 | 34 | 43 | 47 | 55 | 55 |
| +SCI-3112-002 | 1 | 100 | — | 5 | LB | 0.027 μF | 0.016 | (0.41)* | 10 | 20 | 30 | 38 | 45 | 45 | 65 | 70 |
| +SCI-3112-000 | 1 | 100 | — | 5 | LB | 0.027 μF | 0.016 | (0.41) | 10 | 20 | 30 | 38 | 45 | 45 | 65 | 70 |
| SCI-3112-007 | 1 | 100 | — | 10 | LB | 0.027 μF | 0.025 | (0.64) | 10 | 20 | 30 | 38 | 45 | 45 | 65 | 70 |
| SCI-3112-102 | 1 | 100 | — | 3 | LB | 0.05 μF | 0.016 | (0.41)* | 15 | 24 | 35 | 42 | 54 | 56 | 70 | 70 |
| SCI-3112-100 | 1 | 100 | — | 5 | LB | 0.05 μF | 0.016 | (0.41) | 15 | 24 | 35 | 42 | 54 | 56 | 70 | 70 |
| SCI-3112-107 | 1 | 100 | — | 10 | LB | 0.05 μF | 0.025 | (0.64) | 15 | 24 | 35 | 42 | 54 | 56 | 70 | 70 |
| +51-729-303 | 1 | 200 | — | 3 | Pi | 1500 pF | 0.018 | (0.46) | — | — | 5 | 15 | 42 | 65 | 70 | 70 |
| SCI-3122-002 | 1 | 200 | 115 | 3 | LB | 0.01 μF | 0.016 | (0.41)* | — | 12 | 21 | 30 | 41 | 45 | 70 | 70 |
| SCI-3122-000 | 1 | 200 | 115 | 5 | LB | 0.01 μF | 0.016 | (0.41) | — | 12 | 21 | 30 | 41 | 45 | 70 | 70 |
| SCI-3122-007 | 1 | 200 | 115 | 10 | LB | 0.01 μF | 0.025 | (0.64) | — | 12 | 21 | 30 | 41 | 45 | 70 | 70 |

* Tinned, steel leads.

+ Also available through API's authorized distributors.

Resin Sealed Bolt-in Filters

6-32 C, L, Pi/6-40 Pi

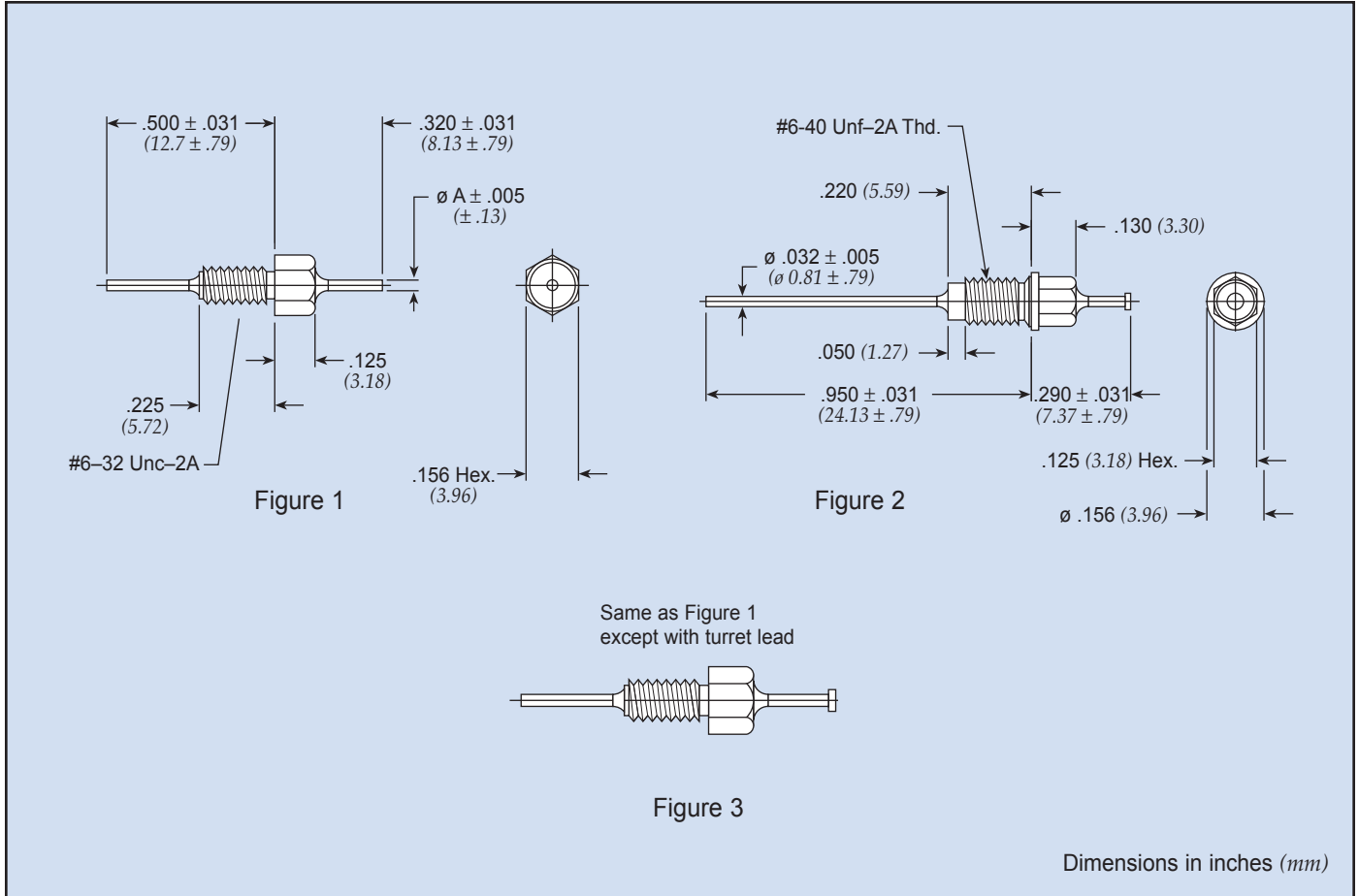

| Part Number | Figure | Rated Voltage 125°C | | I Amp | CKT | Min Cap | A | | Minimum Insertion Loss (dB) | | | | | | | |
|---------------------|--------|---------------------|----|-------|-----|-----------------|-------|--------|-----------------------------|-------|--------|--------|---------|---------|-------|--------|
| | | DC | AC | | | | In | (mm) | 1 MHz | 3 MHz | 10 MHz | 30 MHz | 100 MHz | 300 MHz | 1 GHz | 10 GHz |
| † 51-726-008 | 1 | 50 | — | 3 | Pi | 5500 pF | 0.018 | (0.46) | — | 7 | 14 | 30 | 55 | 70 | 70 | 70 |
| 51-726-017 | 1 | 50 | — | 3 | Pi | 9000 pF | 0.018 | (0.46) | — | 8 | 18 | 45 | 65 | 70 | 70 | 70 |
| 54-779-019 | 1 | 50 | — | 10 | C | 0.10 μ F | 0.032 | (0.81) | 22 | 31 | 40 | 44 | 47 | 55 | 65 | 65 |
| † 54779001X5F100M | 1 | 100 | — | 10 | C | 10 pF \pm 20% | 0.032 | (0.81) | — | — | — | — | — | — | 10 | 10 |
| † 54779001X5U102P € | 1 | 100 | — | 10 | C | 1000 pF | 0.032 | (0.81) | — | — | — | 10 | 21 | 28 | 28 | 28 |
| 54-779-014 | 1 | 100 | — | 10 | C | 2700 pF | 0.032 | (0.81) | — | — | 9 | 18 | 27 | 33 | 35 | 35 |
| 54-779-016 | 1 | 100 | — | 10 | C | 0.01 μ F | 0.032 | (0.81) | — | 9 | 20 | 29 | 38 | 45 | 50 | 50 |
| † 51-726-002 | 3 | 100 | — | 10 | LB | 0.022 μ F | 0.032 | (0.81) | 7 | 17 | 27 | 34 | 43 | 50 | 60 | 60 |
| 54-779-017 | 1 | 100 | — | 10 | C | 0.027 μ F | 0.032 | (0.81) | 10 | 20 | 30 | 37 | 45 | 50 | 55 | 60 |
| 54-779-018 | 1 | 100 | — | 10 | C | 0.050 μ F | 0.032 | (0.81) | 15 | 24 | 34 | 41 | 45 | 50 | 60 | 60 |
| † 51-726-001 | 1 | 200 | — | 3 | Pi | 1500 pF | 0.018 | (0.46) | — | — | 5 | 15 | 42 | 65 | 70 | 70 |
| † 1289-001 | 2 | 200 | — | 10 | Pi | 1500 pF | 0.032 | (0.81) | — | — | 5 | 15 | 40 | 60 | 60 | 60 |
| † 1289-004 | 2 | 200 | — | 10 | Pi | 3000 pF | 0.032 | (0.81) | — | — | 8 | 15 | 50 | 65 | 70 | 70 |
| 54-779-015 | 1 | 200 | — | 10 | C | 5600 pF | 0.032 | (0.81) | — | — | 15 | 24 | 33 | 37 | 40 | 40 |

† Also available through API's authorized distributors.

€ Also available through API's authorized European distributors/agents.

Resin Sealed Bolt-in Filters



8-32 C Circuit

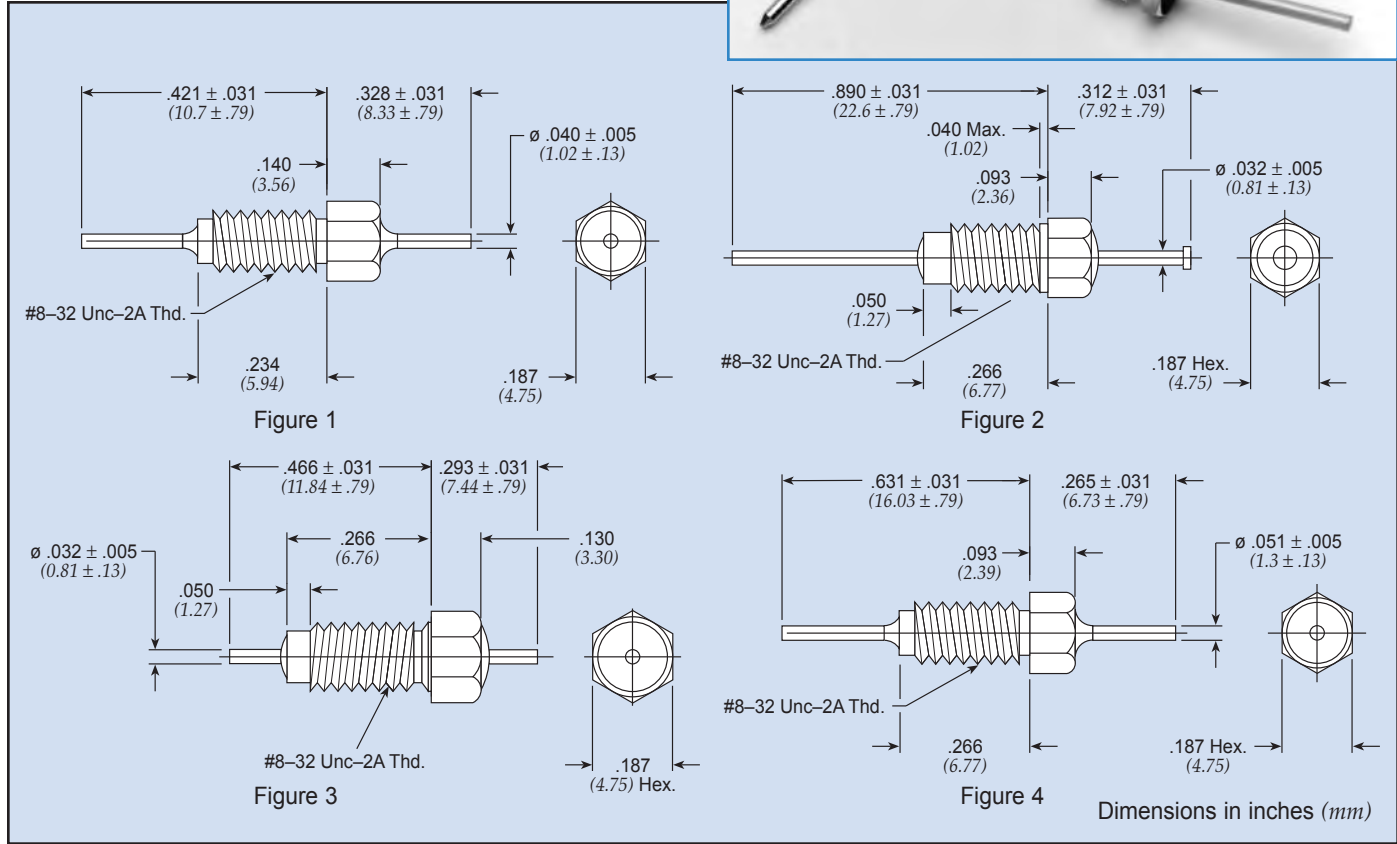

| Part Number | Figure | Rated Voltage 125°C | | I Amp | Min Cap | Minimum Insertion Loss (dB) | | | | | | | |
|-------------------|--------|------------------------|-----|----------|------------|-----------------------------|----------|-----------|-----------|------------|------------|----------|-----------|
| | | DC | AC | | | 1 MHz | 3 MHz | 10 MHz | 30 MHz | 100 MHz | 300 MHz | 1 GHz | 10 GHz |
| SCI-9200-503 | 2 | 50 | — | 10 | 0.05 µF | 15 | 24 | 35 | 41 | 45 | 50 | 60 | 60 |
| 9950-381-6009 | 3 | 50 | — | 10 | 0.12 µF | 20 | 30 | 43 | 45 | 55 | 55 | 55 | 55 |
| 54-785-017 | 1 | 50 | — | 10 | 0.21 µF | 28 | 37 | 45 | 50 | 55 | 60 | 70 | 70 |
| 9950-381-6008 | 3 | 70 | — | 10 | 0.08 µF | 15 | 24 | 37 | 41 | 51 | 51 | 55 | 55 |
| † 54713001X5F101M | 4 | 100 | — | 10 | 80 pF | — | — | — | — | — | 10 | 20 | 20 |
| † 54713001X5U102P | 4 | 100 | — | 10 | 1000 pF | — | — | — | 11 | 20 | 28 | 28 | 28 |
| 54-785-013 | 1 | 100 | — | 10 | 0.01 µF | — | 9 | 20 | 29 | 38 | 45 | 50 | 55 |
| SCI-9210-103 | 2 | 100 | — | 10 | 0.01 µF | — | 12 | 20 | 29 | 38 | 45 | 50 | 50 |
| SCI-9210-273 | 2 | 100 | — | 10 | 0.027 µF | 10 | 20 | 30 | 36 | 45 | 50 | 55 | 60 |
| † 54-785-005 | 1 | 100 | — | 10 | 0.05 µF | 15 | 24 | 34 | 41 | 45 | 50 | 60 | 60 |
| 54-785-016 | 1 | 100 | — | 10 | 0.1 µF | 20 | 29 | 38 | 44 | 47 | 55 | 65 | 65 |
| 54-785-011 | 1 | 150 | — | 10 | 2000 pF | — | — | 8 | 17 | 26 | 32 | 34 | 35 |
| 54-785-012 | 1 | 150 | — | 10 | 5000 pF | — | 6 | 15 | 24 | 33 | 37 | 40 | 40 |
| SCI-9220-101 | 2 | 200 | 115 | 10 | 100 pF | — | — | — | — | — | 10 | 20 | 25 |
| SCI-9220-102 | 2 | 200 | 115 | 10 | 1000 pF | — | — | — | 11 | 20 | 28 | 28 | 28 |
| SCI-9220-502 | 2 | 200 | 115 | 10 | 5000 pF | — | 6 | 15 | 24 | 33 | 37 | 40 | 40 |

† Also available through API's authorized distributors.

Resin Sealed Bolt-in Filters

8-32 L & Pi Circuit

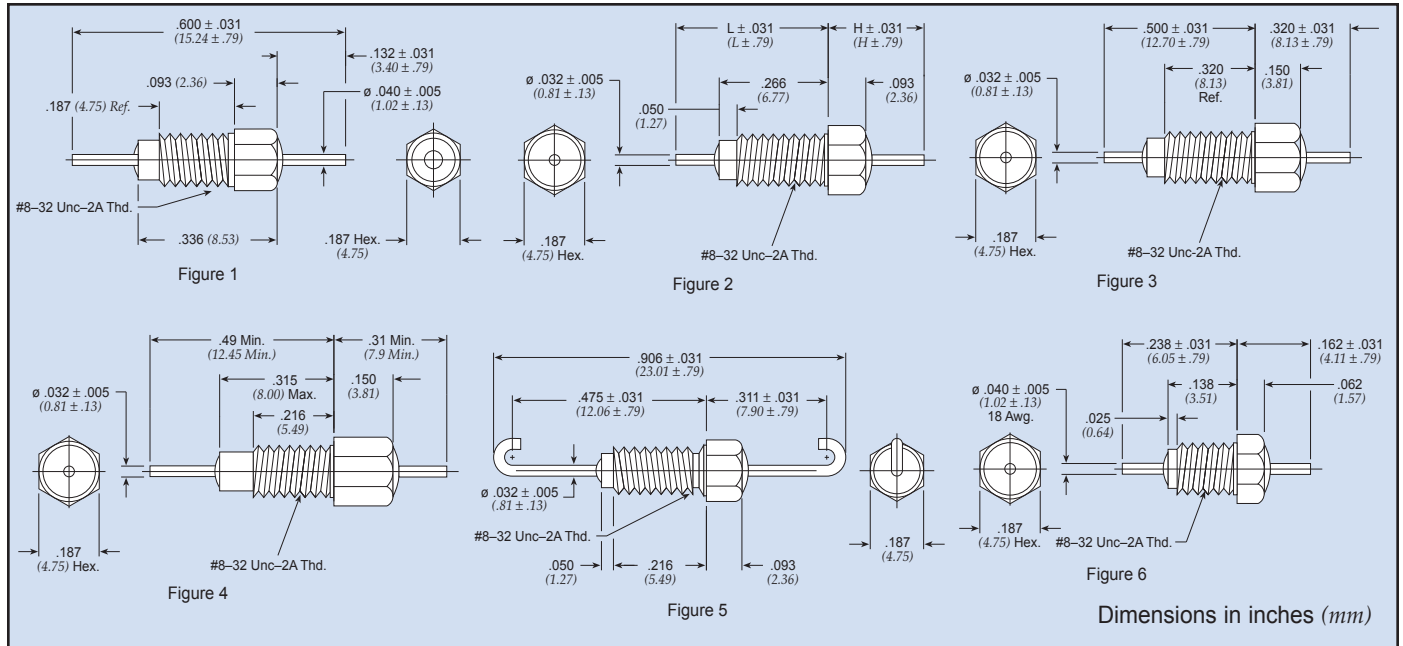

| Part Number | M15733 MIL Number | Fig. | Rated Voltage 125°C | | I Amp | CKT | Min Cap | In | H (mm) | L In (mm) | Minimum Insertion Loss (dB) | | | | | | | | |
|-------------------------|-------------------|------|---------------------|-----|-------|-----|---------------|-------|--------|-----------|-----------------------------|-------|--------|--------|---------|---------|-------|--------|----|
| | | | DC | AC | | | | | | | 1 MHz | 3 MHz | 10 MHz | 30 MHz | 100 MHz | 300 MHz | 1 GHz | 10 GHz | |
| 51-712-069 € | — | 2 | 50 | — | 10 | Pi | 0.012 μ F | 0.265 | (6.73) | 0.413 | (10.49) | 5 | 9 | 18 | 45 | 65 | 70 | 70 | 70 |
| † 51-712-065 | /61-0014 | 4 | 50 | — | 20 | Pi | 0.012 μ F | 0.310 | (7.87) | 0.490 | (12.45) | — | 10 | 20 | 30 | 65 | 70 | 70 | 70 |
| † 1250-054 | — | 2 | 70 | — | 10 | Pi | 5000 pF | 0.312 | (7.92) | 0.500 | (12.70) | — | — | 20 | 30 | 65 | 65 | 70 | 70 |
| † 1293-001 | — | 3 | 70 | — | 10 | Pi | 0.028 μ F | — | — | — | — | 10 | 14 | 38 | 65 | 75 | 75 | 75 | 75 |
| 51-712-055 | /43-0002 | 2 | 100 | 70 | 10 | Pi | 3000 pF | 0.312 | (7.92) | 0.578 | (14.68) | — | — | 5 | 15 | 45 | 50 | 50 | 50 |
| † 51-712-014 | /28-0001 | 2 | 100 | 70 | 10 | Pi | 3000 pF | 0.312 | (7.92) | 0.890 | (22.61) | — | — | 5 | 15 | 45 | 60 | 60 | 60 |
| 51-712-028 | /28-0002 | 5 | 100 | 70 | 10 | Pi | 3000 pF | — | — | — | — | — | — | 5 | 15 | 45 | 60 | 60 | 60 |
| † 51-712-063* | /61-0008 | 2 | 100 | 70 | 10 | Pi | 5500 pF | 0.312 | (7.92) | 0.500 | (12.70) | — | — | 15 | 35 | 65 | 70 | 70 | 70 |
| † 51-712-003 \diamond | — | 2 | 100 | — | 10 | LB | 0.022 μ F | 0.280 | (7.11) | 0.850 | (21.59) | 7 | 17 | 27 | 34 | 43 | 50 | 60 | 60 |
| 51-712-060 \diamond | /28-0004 | 2 | 100 | 70 | 10 | LB | 0.022 μ F | 0.312 | (7.92) | 0.890 | (22.61) | 10 | 17 | 28 | 34 | 41 | 50 | 60 | 60 |
| † 51-712-067 | /61-0013 | 2 | 100 | — | 10 | LB | 0.031 μ F | 0.280 | (7.11) | 0.890 | (22.61) | 10 | 20 | 30 | 38 | 42 | 52 | 60 | 60 |
| 51-762-006 | /44-0003 | 6 | 125 | 85 | 15 | Pi | 65 pF | — | — | — | — | — | — | — | — | — | — | 16 | 42 |
| † 1250-059 | — | 6 | 125 | — | 15 | Pi | 1500 pF | — | — | — | — | — | — | 5 | 15 | 35 | 45 | 60 | 60 |
| † 51-762-005 | /44-0002 | 6 | 125 | 85 | 15 | Pi | 1500 pF | — | — | — | — | — | — | 5 | 15 | 25 | 35 | 50 | 50 |
| 1250-062 | — | 1 | 125 | — | 15 | Pi | 3000 pF | — | — | — | — | — | — | 5 | 15 | 45 | 45 | 70 | 70 |
| † 51-744-003* | /44-0001 | 1 | 125 | 85 | 15 | Pi | 3000 pF | — | — | — | — | — | — | 10 | 15 | 30 | 40 | 65 | 65 |
| † SCI-3223-000 | — | 2 | 200 | 115 | 10 | Pi | 2000 pF | 0.312 | (7.92) | 0.890 | (22.61) | — | — | 8 | 10 | 48 | 50 | 70 | 70 |
| † 1250-003 € | — | 2 | 200 | — | 10 | Pi | 3000 pF | 0.312 | (7.92) | 0.890 | (22.61) | — | — | 5 | 15 | 45 | 65 | 70 | 70 |
| † 51-712-001* | — | 2 | 200 | — | 10 | Pi | 3000 pF | 0.312 | (7.92) | 0.890 | (22.61) | — | — | 5 | 15 | 45 | 65 | 70 | 70 |
| 1250-049 | — | 2 | 200 | — | 10 | Pi | 3000 pF | 0.312 | (7.92) | 0.578 | (14.68) | — | — | 5 | 15 | 45 | 65 | 65 | 60 |
| † 51-744-002 \diamond | — | 2 | 200 | — | 10 | Pi | 5500 pF | 0.265 | (6.73) | 0.413 | (10.49) | — | 7 | 14 | 30 | 55 | 70 | 70 | 70 |
| † 1293-000 | — | 3 | 200 | — | 10 | Pi | 0.012 μ F | — | — | — | — | 5 | 10 | 28 | 40 | 65 | 70 | 70 | 70 |

† Also available through API's authorized distributors.

\diamond Supplied with .040" (1.02mm) diameter lead.

€ Also available through API's authorized European distributors/agents.

* Denotes parts with turret lead.

Resin Sealed Bolt-in Filters

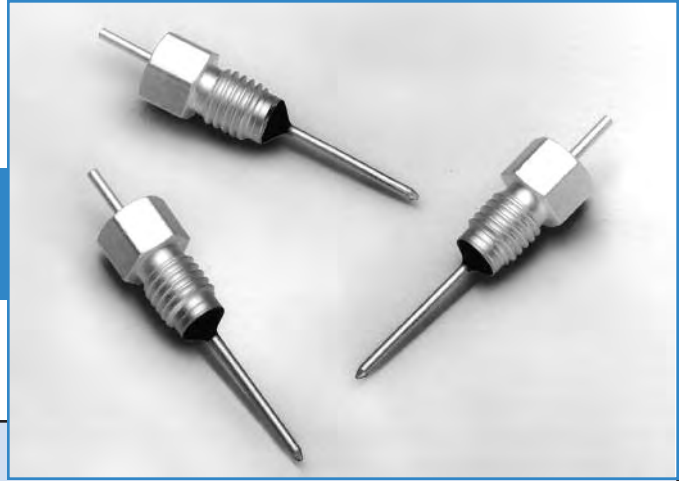

10-32 C & Pi Circuit

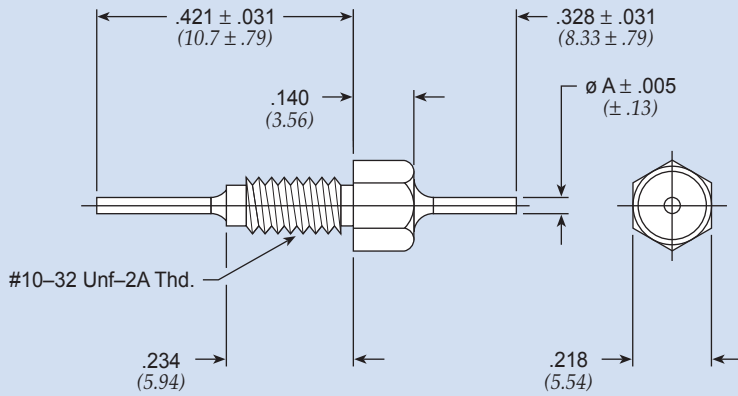

Figure 1

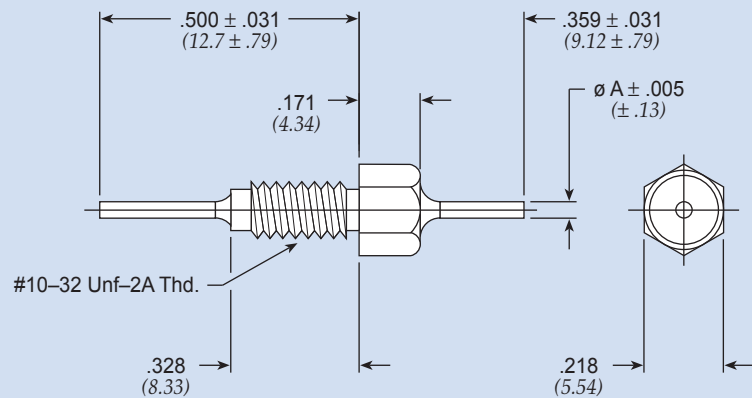

Figure 2

Dimensions in inches (mm)

| Part Number | Figure | Rated Voltage 125°C | | I Amp | CKT | Min Cap | A | | Minimum Insertion Loss (dB) | | | | | | | |
|--------------|--------|------------------------|----|----------|-----|------------|-------|--------|-----------------------------|----------|-----------|-----------|------------|------------|----------|-----------|
| | | DC | AC | | | | In | (mm) | 1 MHz | 3 MHz | 10 MHz | 30 MHz | 100 MHz | 300 MHz | 1 GHz | 10 GHz |
| 51-761-002 | 1 | 50 | — | 10 | Pi | 0.018 μF | 0.032 | (0.81) | 7 | 14 | 30 | 55 | 70 | 70 | 70 | 70 |
| † 54-786-013 | 1 | 50 | — | 10 | C | 0.3 μF | 0.040 | (1.02) | 30 | 38 | 47 | 50 | 55 | 60 | 70 | 70 |
| 54-786-028 | 1 | 50 | — | 10 | C | 0.56 μF | 0.040 | (1.02) | 35 | 43 | 50 | 52 | 60 | 65 | 70 | 70 |
| † 54-786-014 | 2 | 50 | — | 10 | C | 0.8 μF | 0.040 | (1.02) | 40 | 46 | 52 | 54 | 70 | 70 | 70 | 70 |
| 51-761-001 | 1 | 100 | — | 10 | Pi | 0.01 μF | 0.032 | (0.81) | — | 10 | 20 | 45 | 65 | 70 | 70 | 70 |
| 54-786-027 | 1 | 200 | — | 10 | C | 0.1 μF | 0.040 | (1.02) | 20 | 29 | 38 | 44 | 47 | 55 | 65 | 65 |

† Also available through API's authorized distributors.

Resin Sealed Bolt-in Filters

12-28 C /12-32 C Circuit

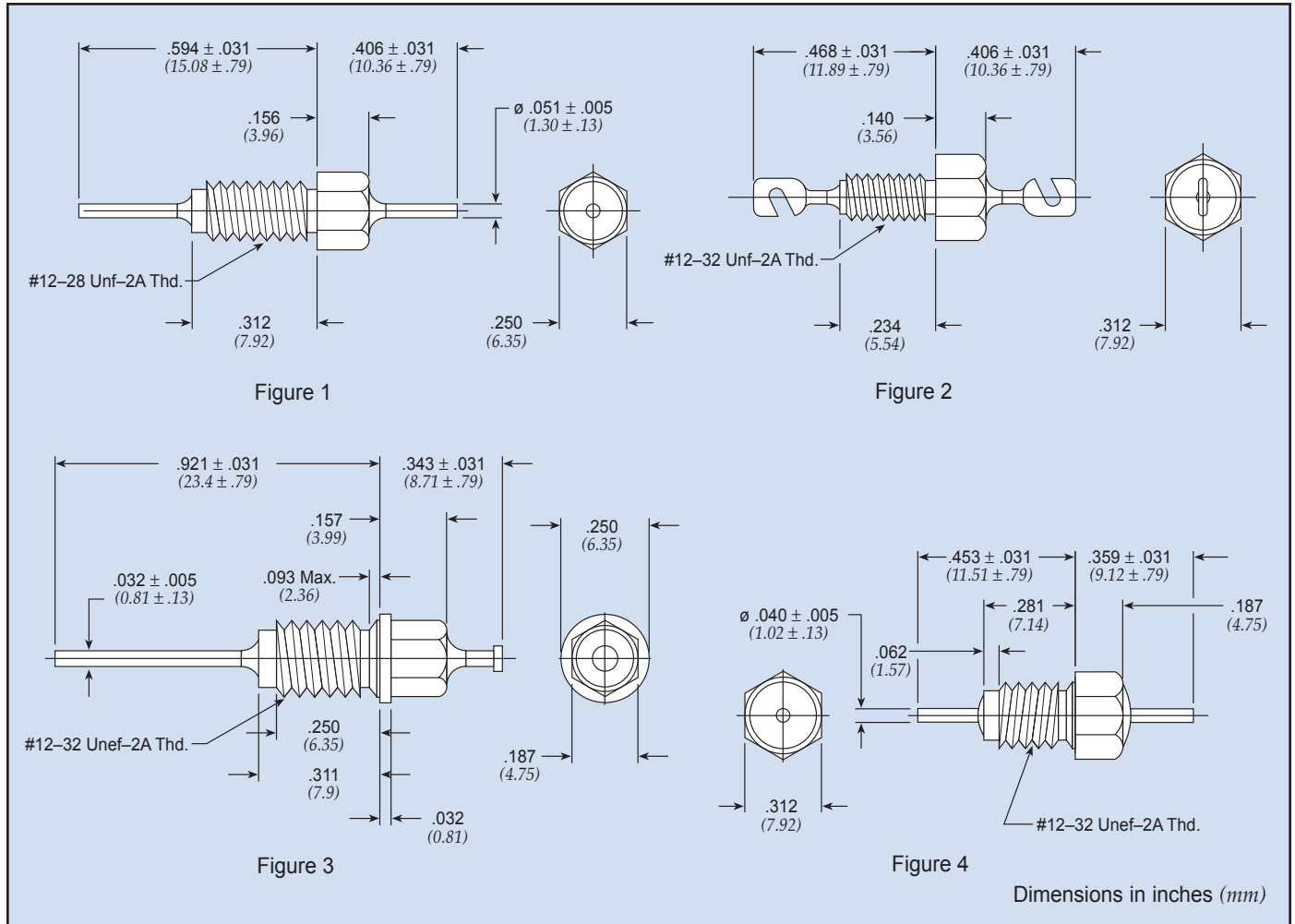

| Part Number | Figure | Rated Voltage 125°C | | I Amp | CKT | Min Cap | Minimum Insertion Loss (dB) | | | | | | | |
|-------------------|--------|------------------------|----|----------|-----|------------------|-----------------------------|----------|-----------|-----------|------------|------------|----------|-----------|
| | | DC | AC | | | | 1 MHz | 3 MHz | 10 MHz | 30 MHz | 100 MHz | 300 MHz | 1 GHz | 10 GHz |
| 9910-381-6004 | 4 | 35 | — | 15 | C | 1 μ F | 38 | 40 | 52 | 52 | 70 | 70 | 78 | 80 |
| 9910-381-6003 | 4 | 50 | — | 15 | C | 0.75 μ F | 35 | 37 | 51 | 51 | 61 | 61 | 65 | 70 |
| SCI-9310-273 | 3 | 100 | — | 10 | C | 0.027 μ F | 10 | 20 | 30 | 37 | 45 | 50 | 55 | 60 |
| 9910-381-6002 | 4 | 100 | — | 15 | C | 0.30 μ F | 28 | 30 | 45 | 50 | 55 | 55 | 60 | 65 |
| 54804002X5R101M | 2 | 250 | — | 10 | C | 100 pF \pm 20% | — | — | — | — | — | 10 | 20 | 25 |
| † 54804002X5R471M | 2 | 250 | — | 10 | C | 470 pF \pm 20% | — | — | — | — | 12 | 22 | 25 | 28 |
| † 54804002X5V102P | 2 | 250 | — | 10 | C | 1000 pF | — | — | — | 10 | 21 | 28 | 28 | 28 |
| 54743001X5U102Z | 1 | 250 | — | 15 | C | 1000 pF | — | — | — | — | 20 | 28 | 28 | 28 |

† Also available through API's authorized distributors.

Resin Sealed Bolt-in Filters



12-28 & 12-32 Pi Circuit

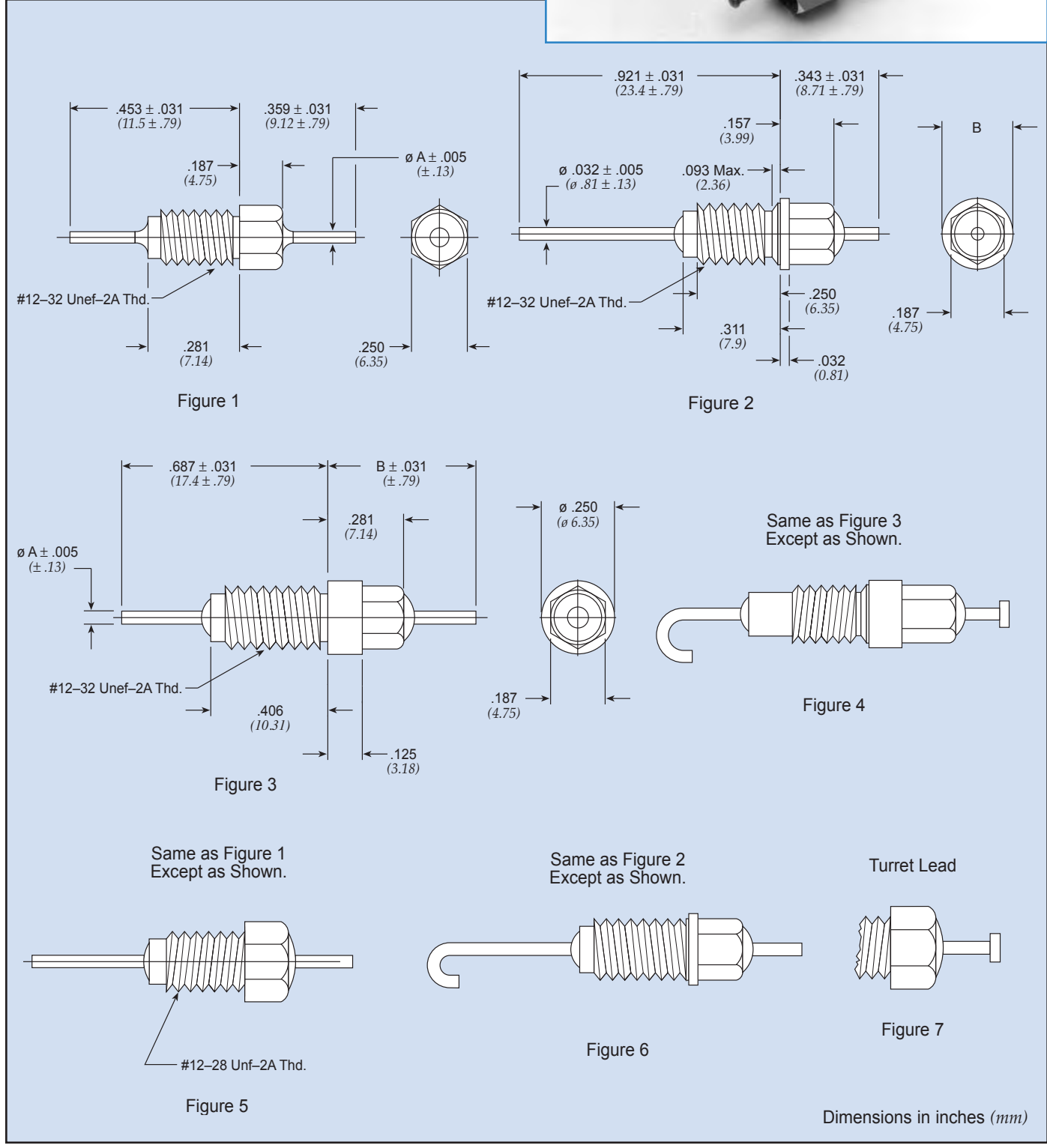

Resin Sealed Bolt-in Filters

12-28 & 12-32 Pi Circuit

| Part Number | M15733 MIL Number | See Pg. LP20 for Fig. | Rated Voltage 125°C | | I Amp | Min Cap | A | | B | | Minimum Insertion Loss (dB) | | | | | | | |
|-----------------|-------------------|-----------------------|---------------------|-----|-------|----------|-------|--------|-------|---------|-----------------------------|-------|--------|--------|---------|---------|-------|--------|
| | | | DC | AC | | | In | (mm) | In | (mm) | 1 MHz | 3 MHz | 10 MHz | 30 MHz | 100 MHz | 300 MHz | 1 GHz | 10 GHz |
| 51-709-013 | — | 3 | 50 | — | 10 | 0.1 µF | 0.040 | (1.02) | 0.437 | (11.10) | 10 | 40 | 52 | 70 | 70 | 70 | 70 | 70 |
| SCI-3303-000* | — | 2 | 50 | — | 10 | 0.15 µF | 0.032 | (0.81) | 0.250 | (6.35) | 12 | 43 | 68 | 70 | 70 | 70 | 70 | 70 |
| 51-709-015 | /61-0009 | 3 | 70 | — | 10 | 0.012 µF | 0.032 | (0.81) | 0.470 | (11.94) | — | — | — | — | 65 | 65 | 65 | 65 |
| † 1216-001 | — | 3 | 70 | — | 10 | 0.050 µF | 0.032 | (0.81) | 0.468 | (11.89) | 15 | 20 | 60 | 65 | 75 | 75 | 75 | 75 |
| † 1270-016* | — | 2 | 100 | — | 10 | 5500 pF | 0.032 | (0.81) | 0.250 | (6.35) | — | 7 | 20 | 35 | 65 | 70 | 70 | 70 |
| † 1270-025 | — | 2 | 100 | — | 10 | 5500 pF | 0.032 | (0.81) | 0.235 | (5.97) | — | 7 | 20 | 35 | 65 | 70 | 70 | 70 |
| † 1201-066 | — | 1 | 100 | — | 10 | 5500 pF | 0.032 | (0.81) | — | — | — | 7 | 20 | 40 | 68 | 70 | 70 | 70 |
| 51-714-055* | /61-0011 | 2 | 100 | — | 10 | 5500 pF | 0.032 | (0.81) | 0.235 | (5.97) | — | 7 | 20 | — | 65 | 70 | 70 | 70 |
| 51-714-054* | /61-0010 | 2 | 100 | — | 10 | 5500 pF | 0.032 | (0.81) | 0.250 | (6.35) | — | 7 | 20 | — | 65 | 70 | 70 | 70 |
| 51-714-053* | /61-0007 | 2 | 100 | 70 | 10 | 5500 pF | 0.032 | (0.81) | 0.250 | (6.35) | — | 7 | — | — | 65 | 70 | 70 | 70 |
| 51-714-058* | — | 2 | 100 | — | 10 | 0.025 µF | 0.032 | (0.81) | 0.250 | (6.35) | 10 | 15 | 40 | 60 | 70 | 70 | 70 | 70 |
| 51-714-056 | /61-0012 | 6 | 100 | — | 10 | 0.025 µF | 0.032 | (0.81) | 0.235 | (5.97) | — | — | — | — | 65 | 65 | 65 | 65 |
| † SCI-3313-000* | — | 2 | 100 | — | 10 | 0.10 µF | 0.032 | (0.81) | 0.250 | (6.35) | 10 | 40 | 65 | 70 | 70 | 70 | 70 | 70 |
| 51-719-022 | — | 1 | 200 | — | 10 | 1300 pF | 0.040 | (1.02) | — | — | — | — | 5 | 10 | 35 | 60 | 70 | 70 |
| † 1201-052 | — | 5 | 200 | — | 10 | 3000 pF | 0.032 | (0.81) | — | — | — | — | 5 | 15 | 45 | 45 | 70 | 70 |
| † 1201-054 | — | 1 | 200 | — | 10 | 3000 pF | 0.032 | (0.81) | — | — | — | — | 5 | 15 | 45 | 45 | 70 | 70 |
| 51-714-001* | — | 2 | 200 | — | 10 | 3000 pF | 0.032 | (0.81) | 0.250 | (6.35) | — | — | 5 | 15 | 43 | 60 | 70 | 70 |
| † 1270-024 | — | 2 | 200 | — | 10 | 3000 pF | 0.032 | (0.81) | 0.235 | (5.97) | — | — | 5 | 15 | 45 | 45 | 70 | 70 |
| 51-714-003* | — | 2 | 200 | — | 10 | 3000 pF | 0.032 | (0.81) | 0.235 | (5.97) | — | — | 5 | 15 | 43 | 60 | 70 | 70 |
| † 1270-009 | — | 2 | 200 | — | 10 | 3000 pF | 0.032 | (0.81) | 0.250 | (6.35) | — | — | 5 | 15 | 45 | 45 | 70 | 70 |
| 51-719-053** | /61-0001 | 5 | 200 | 140 | 10 | 3000 pF | 0.032 | (0.81) | — | — | — | — | — | — | 45 | — | 70 | 70 |
| 51-719-054* | /61-0002 | 1 | 200 | 140 | 10 | 1500 pF | 0.032 | (0.81) | — | — | — | — | — | — | 45 | 45 | 70 | 70 |
| 51-714-051* | /61-0005 | 2 | 200 | 140 | 10 | 1500 pF | 0.032 | (0.81) | 0.250 | (6.35) | — | — | — | — | 45 | 45 | 70 | 70 |
| 51-719-023* | /43-0001 | 5 | 200 | 140 | 10 | 3000 pF | 0.032 | (0.81) | — | — | — | — | — | — | 45 | 45 | 45 | 45 |
| 51-714-052* | /61-0006 | 2 | 200 | 140 | 10 | 3000 pF | 0.032 | (0.81) | 0.235 | (5.97) | — | — | — | — | 45 | 45 | 70 | 70 |
| 51-714-004* | — | 2 | 200 | — | 10 | 5500 pF | 0.032 | (0.81) | 0.235 | (5.97) | — | 7 | 14 | 35 | 60 | 70 | 70 | 70 |
| † 51-719-021 | — | 1 | 200 | — | 10 | 5500 pF | 0.040 | (1.02) | — | — | — | 7 | 14 | 30 | 50 | 65 | 65 | 65 |
| € 51-714-002* | — | 2 | 200 | — | 10 | 5500 pF | 0.032 | (0.81) | 0.250 | (6.35) | — | 7 | 14 | 35 | 60 | 70 | 70 | 70 |
| † SCI-3323-000* | — | 2 | 200 | 115 | 10 | 0.012 µF | 0.032 | (0.81) | 0.250 | (6.35) | — | — | 27 | 30 | 70 | 70 | 70 | 70 |
| † 1221-001 | — | 4 | 300 | — | 10 | 5500 pF | 0.032 | (0.81) | 0.437 | (11.10) | — | — | 15 | 30 | 65 | 70 | 70 | 70 |
| † 51-709-004 | /46-0001 | 4 | 300 | — | 10 | 5500 pF | 0.032 | (0.81) | 0.437 | (11.10) | — | — | — | — | 65 | 70 | 70 | 70 |
| 1201-086 | — | 1 | 350 | — | 10 | 2500 pF | 0.040 | (1.02) | — | — | — | — | 5 | 10 | 50 | 50 | 65 | 65 |
| † 51-719-011 € | — | 1 | 500 | — | 10 | 3000 pF | 0.040 | (1.02) | — | — | — | — | 12 | 20 | 45 | 60 | 60 | 60 |

† Also available through API's authorized distributors.
 € Also available through API's authorized European distributors/agents.
 * Denotes parts supplied with lead as shown in Figure 7.
 ** Bushing housing will have 1 1/2 imperfect threads at hex to thread interface.

Resin Sealed Bolt-in Filters

5/16-24 & 5/16-32 C & Pi Circuit

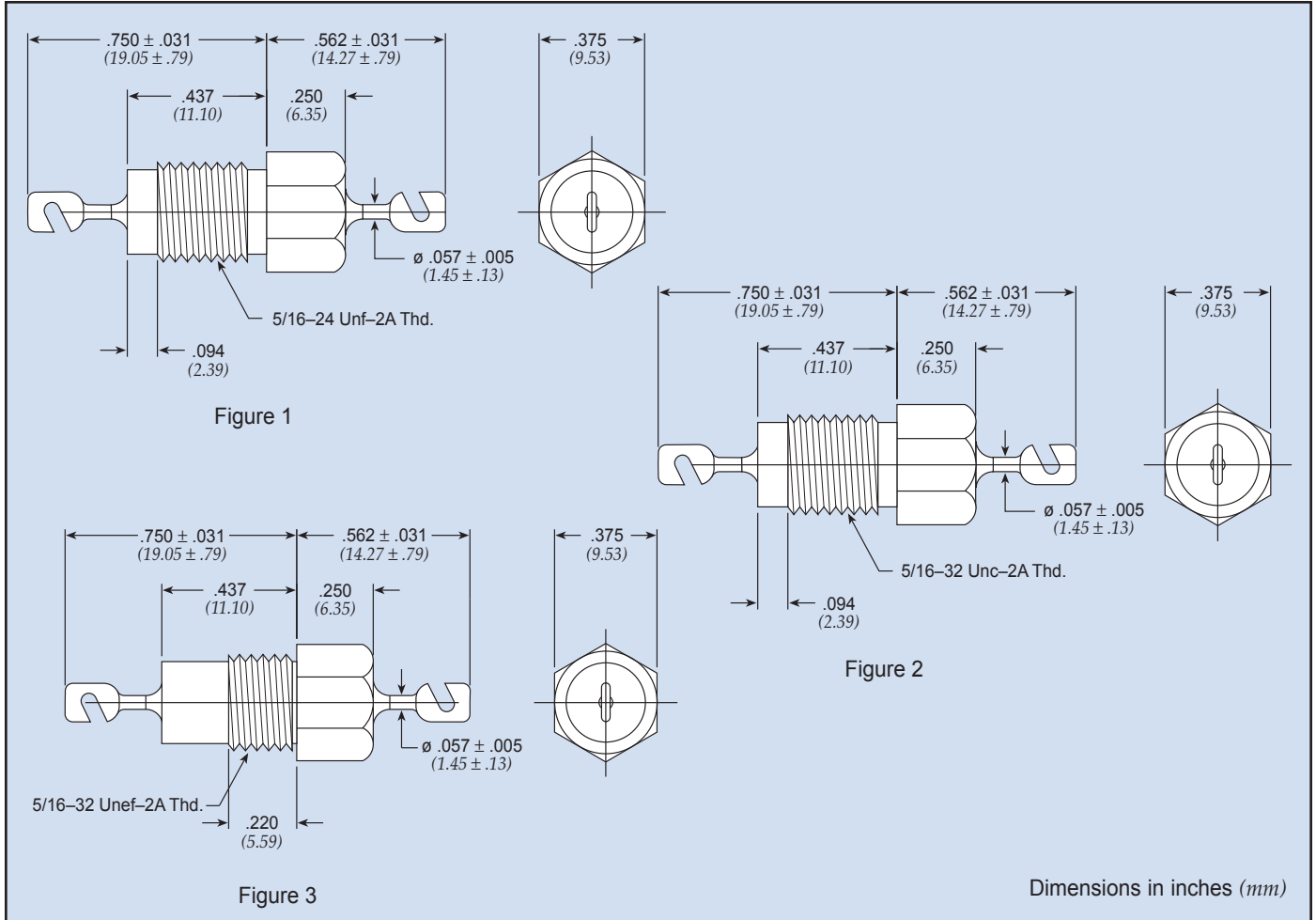

| Part Number | M15733 MIL Number | Fig. | Rated Voltage 125°C | | I Amp | CKT | Min Cap | Minimum Insertion Loss (dB) | | | | | | | |
|--------------|-------------------|------|---------------------|-----|-------|-----|----------|-----------------------------|-------|--------|--------|---------|---------|-------|--------|
| | | | DC | AC | | | | 1 MHz | 3 MHz | 10 MHz | 30 MHz | 100 MHz | 300 MHz | 1 GHz | 10 GHz |
| SCI-9510-503 | — | 1 | 100 | — | 25 | C | 0.05 µF | 15 | 24 | 35 | 41 | 45 | 60 | 60 | 60 |
| SCI-3513-000 | — | 1 | 100 | — | 25 | Pi | 0.1 µF | 10 | 18 | 28 | 37 | 70 | 70 | 70 | 70 |
| SCI-3523-000 | — | 1 | 200 | 115 | 25 | Pi | 0.02 µF | — | — | 25 | 50 | 66 | 66 | 70 | 70 |
| SCI-3543-000 | — | 1 | 400 | 220 | 25 | Pi | 6000 pF | — | — | 15 | 35 | 54 | 65 | 70 | 70 |
| SCI-9550-102 | — | 1 | 500 | 115 | 25 | C | 1000 pF | — | — | — | 11 | 20 | 28 | 28 | 28 |
| † 1202-052 | — | 1 | 500 | — | 25 | Pi | 3000 pF | — | — | 10 | 35 | 55 | 55 | 70 | 70 |
| † 1202-054 | — | 2 | 500 | — | 25 | Pi | 3000 pF | — | — | 10 | 35 | 55 | 55 | 70 | 70 |
| 51-702-020* | /61-0003 | 3 | 500 | 350 | 25 | Pi | 3000 pF | — | — | — | 35 | 55 | 55 | 70 | 70 |
| 51-702-021 | /61-0004 | 3 | 500 | 350 | 25 | Pi | 3000 pF | — | — | 10 | 35 | 55 | 55 | 70 | 70 |
| SCI-9550-332 | — | 1 | 500 | 115 | 25 | C | 3300 pF | — | — | 12 | 20 | 30 | 33 | 40 | 40 |
| SCI-3553-000 | — | 1 | 500 | 220 | 25 | Pi | 0.012 µF | — | — | 18 | 28 | 52 | 52 | 70 | 70 |
| † 1202-005 | — | 2 | 700 | — | 25 | Pi | 2000 pF | — | — | 5 | 20 | 50 | 55 | 70 | 70 |

† Also available through API's authorized distributors.

* Denotes parts with 5/16-24 Threads

Metric Resin Sealed Bolt-in Filters

M3 Pi Circuit & M4 C Circuit

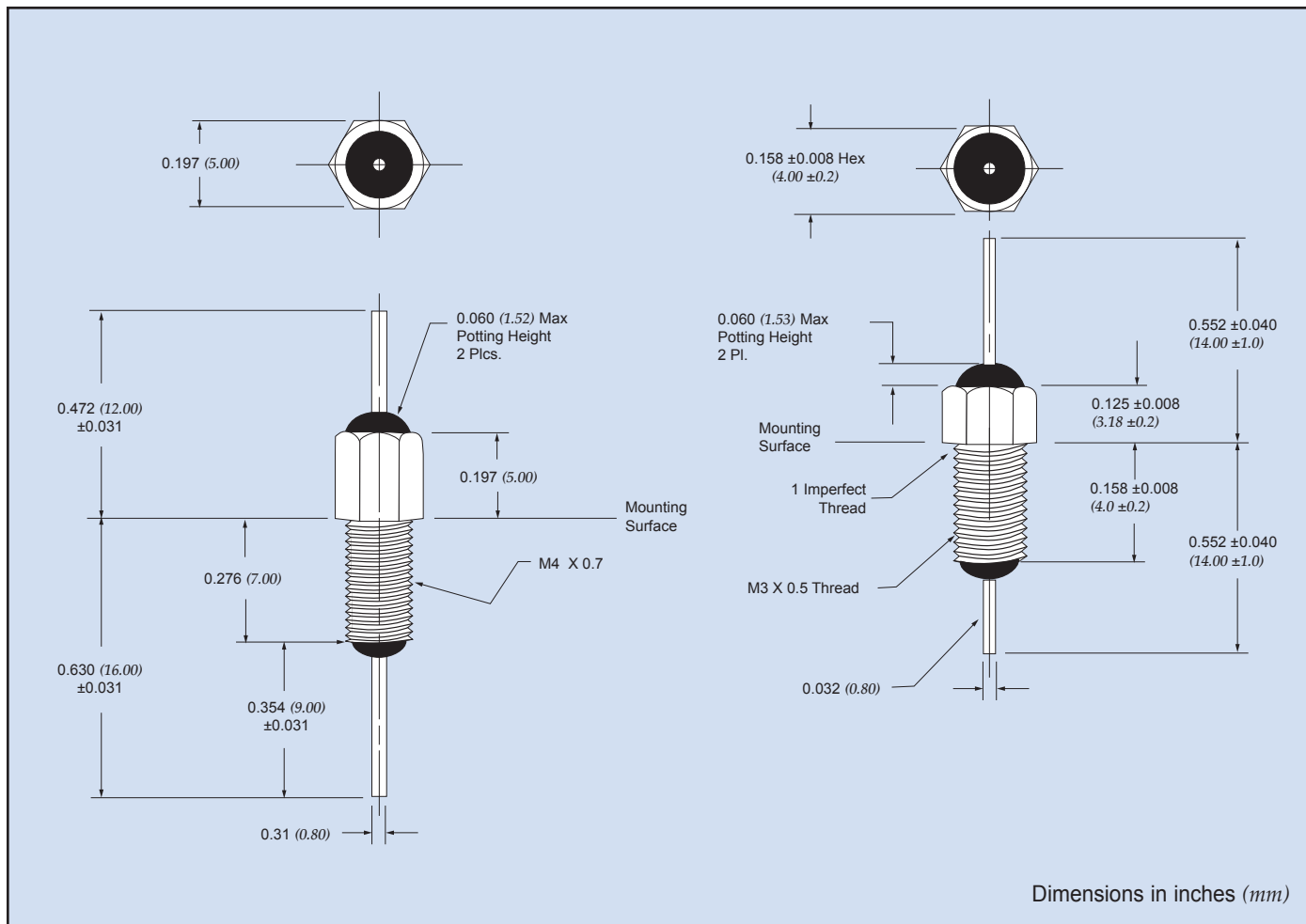

| Part Number | Figure | Rated Voltage 125°C | | I Amp | CKT | Min Cap | Temperature Range |
|-------------|--------|------------------------|--|----------|-----|------------|----------------------|
| | | DC | | | | | |
| 51-831-004 | 1 | 100 | | 3 | Pi | 1000 pF | -55°C to +125°C |
| 51-831-011 | 1 | 100 | | 10 | Pi | 100 pF | -55°C to +125°C |
| 51-831-012 | 1 | 100 | | 10 | Pi | 1500 pF | -55°C to +125°C |
| 51-831-013 | 1 | 100 | | 10 | Pi | 3000 pF | -55°C to +125°C |
| 51-831-014 | 1 | 70 | | 10 | Pi | 5500 pF | -55°C to +125°C |
| 51-831-015 | 1 | 100 | | 10 | Pi | 12000 pF | -55°C to +125°C |
| 54-863-004 | 2 | 100 | | 10 | C | 10000 pF | -55°C to +125°C |
| 54-863-005 | 2 | 100 | | 10 | C | 100 pF | -55°C to +125°C |
| 54-863-007 | 2 | 100 | | 10 | C | 1000 pF | -55°C to +125°C |
| 54-863-008 | 2 | 100 | | 10 | C | 2000 pF | -55°C to +125°C |
| 54-863-010 | 2 | 100 | | 10 | C | 4700 pF | -55°C to +125°C |

RoHS available.

High Current/High Voltage Resin Sealed Filters

High current filters are ideal for use in high current 5 volt logic buss, but also can be used for ± 48 VDC telephone rack buss, high current switch mode power supplies and DC charging systems. High voltage filters find use in high voltage power supplies and applications requiring U.L. Hi-Pot.

Features

- Current ratings up to 100 Amps
- Continuous voltage ratings up to 1250 VDC/240 VAC (400Hz)
- U.L. 1459 recognized and CSA C22.2 approved versions available
- Rugged bolt-in style for easy installation



Installation Notes

for Figure 1 & 2 — see below (Figure 3 see page CF6)

1. Mounting installation torque
 - Method A:** Mounting in full threaded through-hole
Maximum torque: 96 in-lbs
 - Method B:** Mounting w/hardware
Maximum torque: 84 in-lbs
 2. Terminal installation torque
Maximum torque: 20 in-lbs
- Note: Use two-wrench method to install terminal hardware

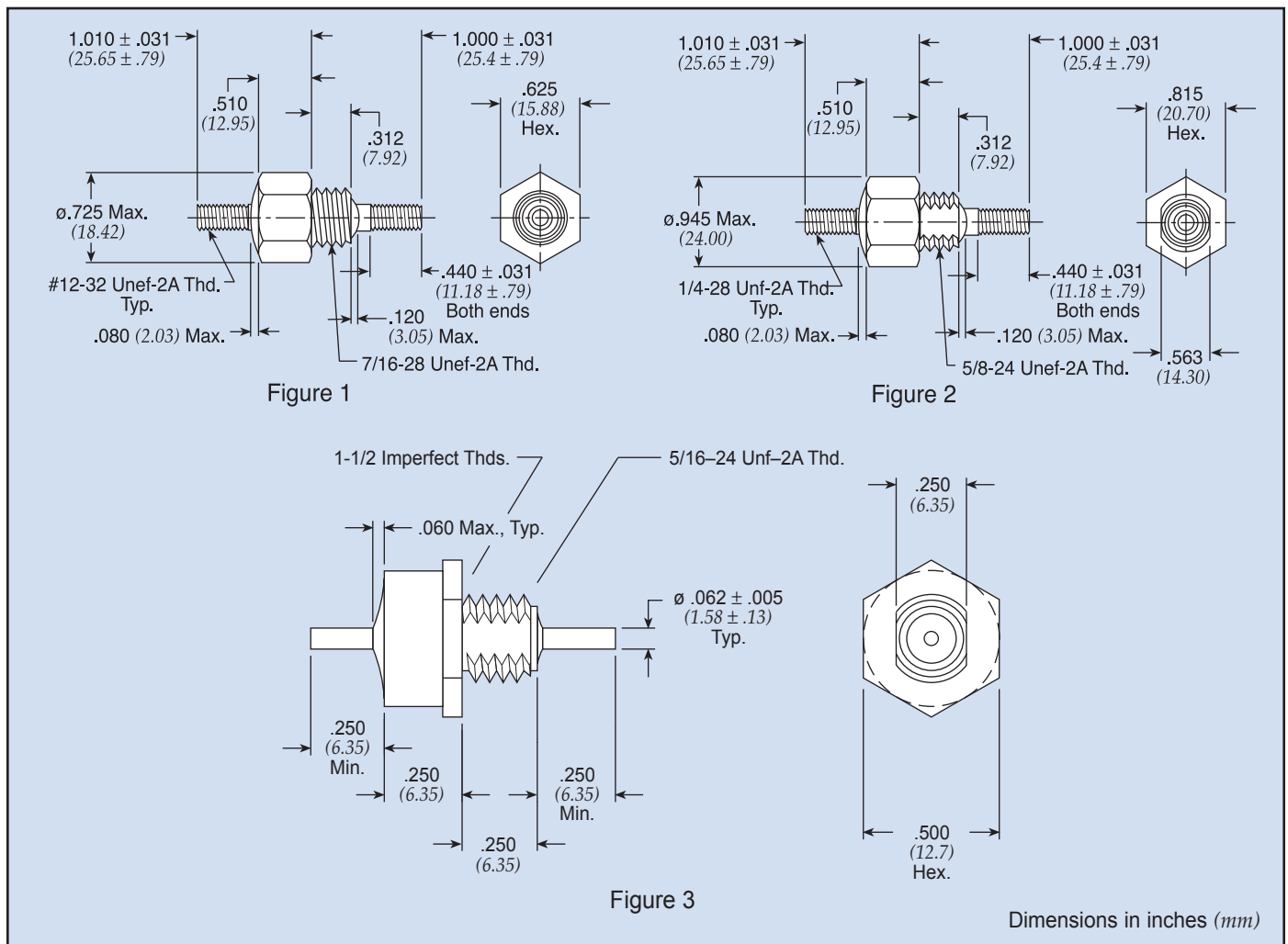

High Current/High Voltage Resin Sealed Filters

High Current High Voltage Feed-through

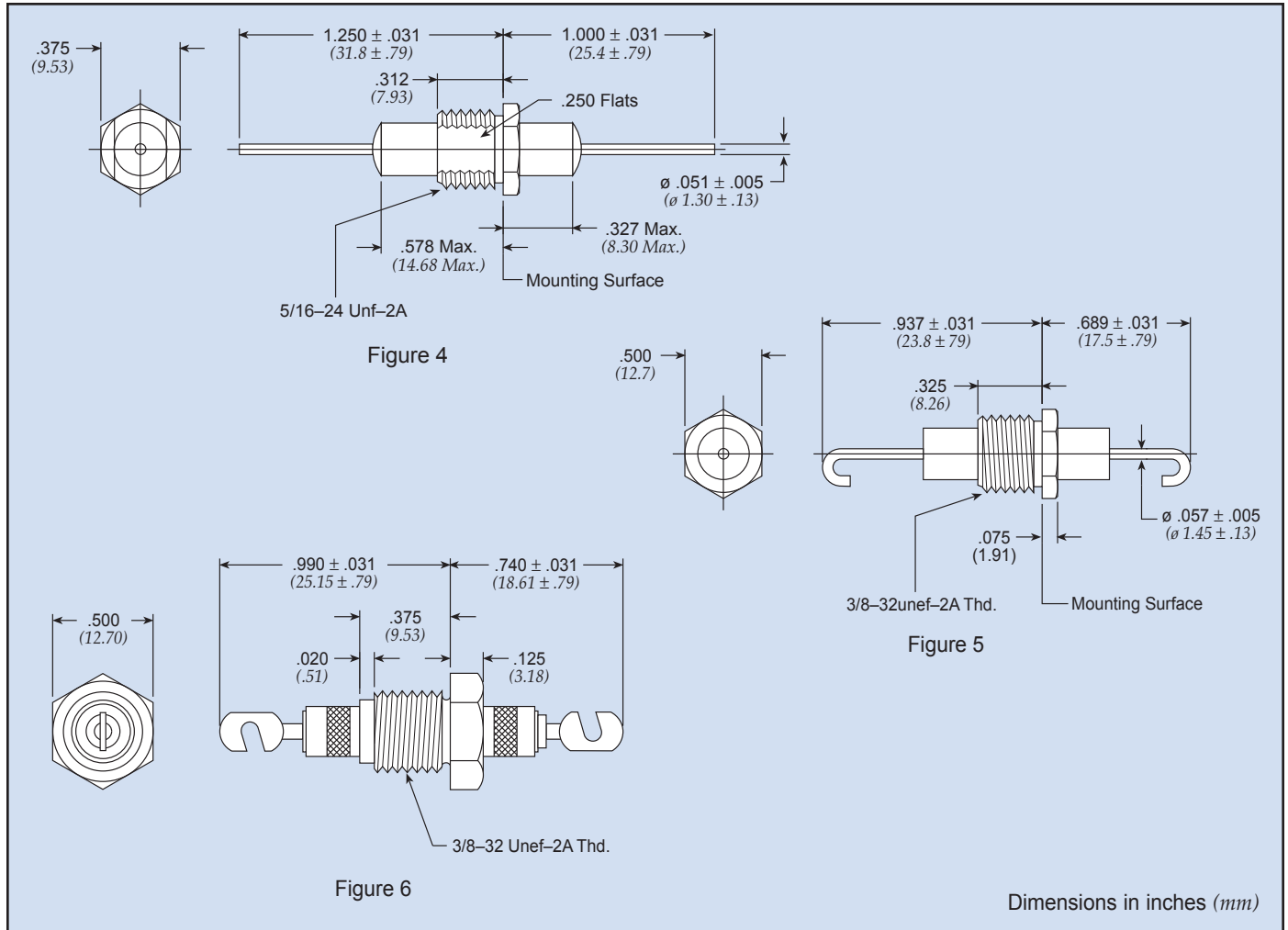

| Part Number | Figure | Rated Voltage 125°C | | I Amp | CKT | Min Cap | Minimum Insertion Loss (dB) | | | | | | | |
|--------------|--------|------------------------|-------|----------|-----|------------------------|-----------------------------|----------|-----------|-----------|------------|------------|----------|-----------|
| | | DC | AC*** | | | | 1 MHz | 3 MHz | 10 MHz | 30 MHz | 100 MHz | 300 MHz | 1 GHz | 10 GHz |
| 54-848-005* | 1 | 60 | — | 50 | C | 0.22 μ F | 20 | 30 | 40 | 50 | 50 | 50 | 50 | 50 |
| 54-853-001* | 2 | 60 | — | 50 | C | 0.22 μ F | 20 | 30 | 40 | 50 | 50 | 50 | 50 | 50 |
| 54-853-004 € | 2 | 200 | 140 | 100 | C | 0.22 μ F | 20 | 30 | 40 | 50 | 50 | 50 | 50 | 50 |
| 54-848-008 | 1 | 200 | 140 | 100 | C | 0.22 μ F | 20 | 30 | 40 | 50 | 50 | 50 | 50 | 50 |
| 54-844-001** | 3 | 600 | 240 | 25 | C | 4700 pF \pm 20% | — | — | 12 | 20 | 30 | 33 | 50 | 50 |
| 54-844-002** | 3 | 600 | 240 | 25 | C | 0.01 μ F \pm 20% | 3 | 7 | 20 | 25 | 35 | 40 | 57 | 57 |
| 54-763-008 | 4 | 750 | — | 25 | C | 1000 pF | — | — | — | 10 | 20 | 28 | 28 | 28 |
| 54-763-009 | 4 | 750 | — | 25 | C | 4000 pF | — | — | 10 | 22 | 32 | 35 | 35 | 40 |
| 54-789-003 | 5 | 1250 | — | 25 | C | 4000 pF | — | — | 6 | 20 | 30 | 35 | 35 | 35 |
| † 1280-060 € | 6 | 2500 | — | 25 | Pi | 1500 pF | — | — | 5 | 15 | 50 | 50 | 50 | 50 |

† Also available through API's authorized distributors.

€ Also available through API's authorized European distributors/agents.

* Denotes parts that are UL recognized to UL 60950 and certified to CSA C22.2

** Denotes parts that meet 1500 VAC Dielectric Withstanding Voltage per UL 1283 and CSA C22.2

*** AC Voltage to be 400Hz

Hermetically Sealed Threaded Case Filters

This series of filters features hermetic glass seals and high EMI filtering performance. They are excellent for critical applications that demand high reliability in the toughest environmental conditions and provide broad-band high performance EMI filtering from 10 KHz to over 10 GHz.

Features

- MIL-F-15733 and MIL-F-28861, DSCC 84084 QPL filters available
- Popular .375", .410" and .690" case diameters
- Voltage ratings from 50 V to 400 VDC/240 AC, 400 Hz
- Impervious to high moisture environments, solvents and severe environmental conditions
- High temperature terminal construction
- D-slotted bushings
- High reliability testing available

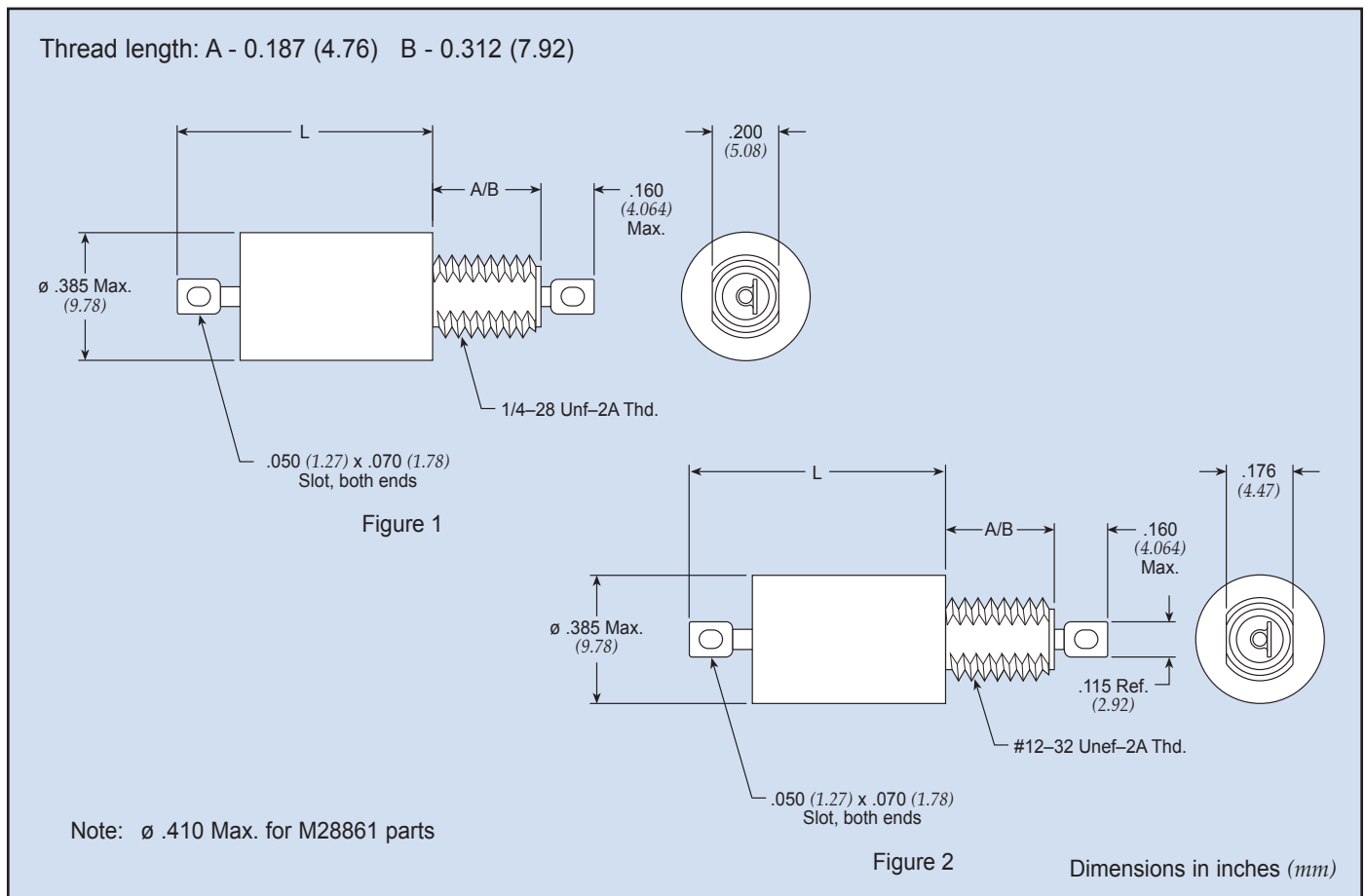

Hermetically Sealed Threaded Case Filters

.375 ø C Circuit Standard

| Part Number | MIL No | See Pg. LP26 for Fig. | Rated Voltage | | | | I Amp | Min Cap µF | DCR Max Ohms | Max L | | Thd Lgth | Minimum Insertion Loss (dB) | | | | | | |
|-----------------|--------|-----------------------|---------------|----|-------|-----|-------|------------|--------------|-------|----------|----------|-----------------------------|---------|---------|-------|--------|---------|-------|
| | | | 85°C | | 125°C | | | | | In | (mm) | | 30 KHz | 150 KHz | 300 KHz | 1 MHz | 10 MHz | 100 MHz | 1 GHz |
| | | | DC | AC | DC | AC | | | | | | | | | | | | | |
| † 54-367-008 | — | 1 | 80 | — | 50 | — | 15 | 1.400 | 0.005 | 0.387 | (9.830) | A | 15 | 28 | 33 | 44 | 60 | 70 | 70 |
| 54-370-007 | — | 1 | 80 | — | 50 | — | 15 | 2.800 | 0.005 | 0.576 | (14.630) | A | 20 | 34 | 39 | 50 | 60 | 70 | 70 |
| 54-371-001 | — | 1 | 80 | — | 50 | — | 15 | 4.000 | 0.005 | 0.688 | (17.475) | A | 26 | 40 | 46 | 55 | 60 | 70 | 70 |
| 54-367-005 | — | 1 | 150 | — | 100 | — | 15 | 0.450 | 0.005 | 0.387 | (9.830) | A | 6 | 19 | 25 | 36 | 55 | 70 | 70 |
| † 9920-100-6002 | — | 1 | 200 | — | 150 | 125 | 15 | 0.150 | 0.005 | 0.387 | (9.830) | A | — | 6 | 15 | 26 | 42 | 55 | 70 |
| 54-367-007 | — | 1 | 250 | — | 200 | 125 | 15 | 0.015 | 0.005 | 0.387 | (9.830) | A | — | — | — | 6 | 25 | 45 | 50 |
| † 54-367-006 | — | 1 | 250 | — | 200 | 125 | 15 | 0.250 | 0.005 | 0.387 | (9.830) | A | — | 14 | 19 | 30 | 50 | 65 | 70 |
| 54-370-006 | — | 1 | 250 | — | 200 | 125 | 15 | 0.500 | 0.005 | 0.630 | (16.002) | A | 7 | 20 | 28 | 39 | 55 | 70 | 70 |
| 9923-100-6004 | — | 1 | 400 | — | 400 | 240 | 15 | 0.060 | 0.005 | 0.415 | (10.541) | A | — | 5 | 10 | 18 | 38 | 55 | 70 |

.375 ø C Circuit MIL Qualified (See MIL index on pages CF9-11 for complete MIL part number listing)

| Part Number | M15733 M28861 MIL No | See Pg. LP26 for Fig. | Rated Voltage | | | | I Amp | Min Cap µF | DCR Max Ohms | Max L | | Thd Lgth | Minimum Insertion Loss (dB) | | | | | | |
|-------------|----------------------|-----------------------|---------------|----|-------|-----|-------|------------|--------------|-------|----------|----------|-----------------------------|---------|---------|-------|--------|---------|-------|
| | | | 85°C | | 125°C | | | | | In | (mm) | | 30 KHz | 150 KHz | 300 KHz | 1 MHz | 10 MHz | 100 MHz | 1 GHz |
| | | | DC | AC | DC | AC | | | | | | | | | | | | | |
| 54-367-054 | 1-012◇ | 1 | — | — | 50 | — | 15 | 1.200 | 0.008 | 0.410 | (10.414) | B | 15 | 28 | 33 | 40 | 40 | 70 | 70 |
| 54-367-049 | 1-002◇ | 1 | — | — | 50 | — | 15 | 1.200 | 0.008 | 0.410 | (10.414) | A | 15 | 28 | 33 | 40 | 40 | 70 | 70 |
| 54-370-032 | 49-0008 | 1 | — | — | 50 | — | 15 | 2.100 | 0.010 | 0.576 | (14.630) | A | 20 | 33 | 40 | 50 | 65 | 70 | 70 |
| 54-367-055 | 1-014◇ | 1 | — | — | 70 | — | 15 | 0.700 | 0.008 | 0.410 | (10.414) | B | 10 | 24 | 30 | 40 | 40 | 64 | 70 |
| 54-370-030 | 34-0035 | 2 | — | — | 100 | — | 10 | 0.300 | 0.004 | 0.474 | (12.040) | A | 7 | 19 | 25 | 35 | 55 | 70 | 70 |
| 54-367-051 | 1-006◇ | 1 | — | — | 100 | — | 15 | 0.450 | 0.008 | 0.410 | (10.414) | A | 6 | 19 | 25 | 36 | 40 | 60 | 70 |
| 54-367-056 | 1-016◇ | 1 | — | — | 100 | — | 15 | 0.450 | 0.008 | 0.410 | (10.414) | B | 6 | 19 | 25 | 36 | 40 | 60 | 70 |
| 54-367-057 | 1-018◇ | 1 | — | — | 150 | — | 15 | 0.250 | 0.008 | 0.410 | (10.414) | B | — | 14 | 20 | 31 | 40 | 56 | 70 |
| 54-367-053 | 1-010◇ | 1 | — | — | 200 | 125 | 15 | 0.150 | 0.008 | 0.410 | (10.414) | A | — | 10 | 16 | 26 | 40 | 52 | 70 |
| 54-367-058 | 1-020◇ | 1 | — | — | 200 | 125 | 15 | 0.150 | 0.008 | 0.410 | (10.414) | B | — | 10 | 16 | 26 | 40 | 52 | 70 |
| 54-370-034 | 49-0010 | 1 | — | — | 330 | — | 15 | 0.062 | 0.004 | 0.680 | (17.272) | A | — | 2 | 7 | 17 | 37 | 55 | 70 |

† Also available through API's authorized distributors.

Hermetically Sealed Threaded Case Filters

.375 ø L Circuit

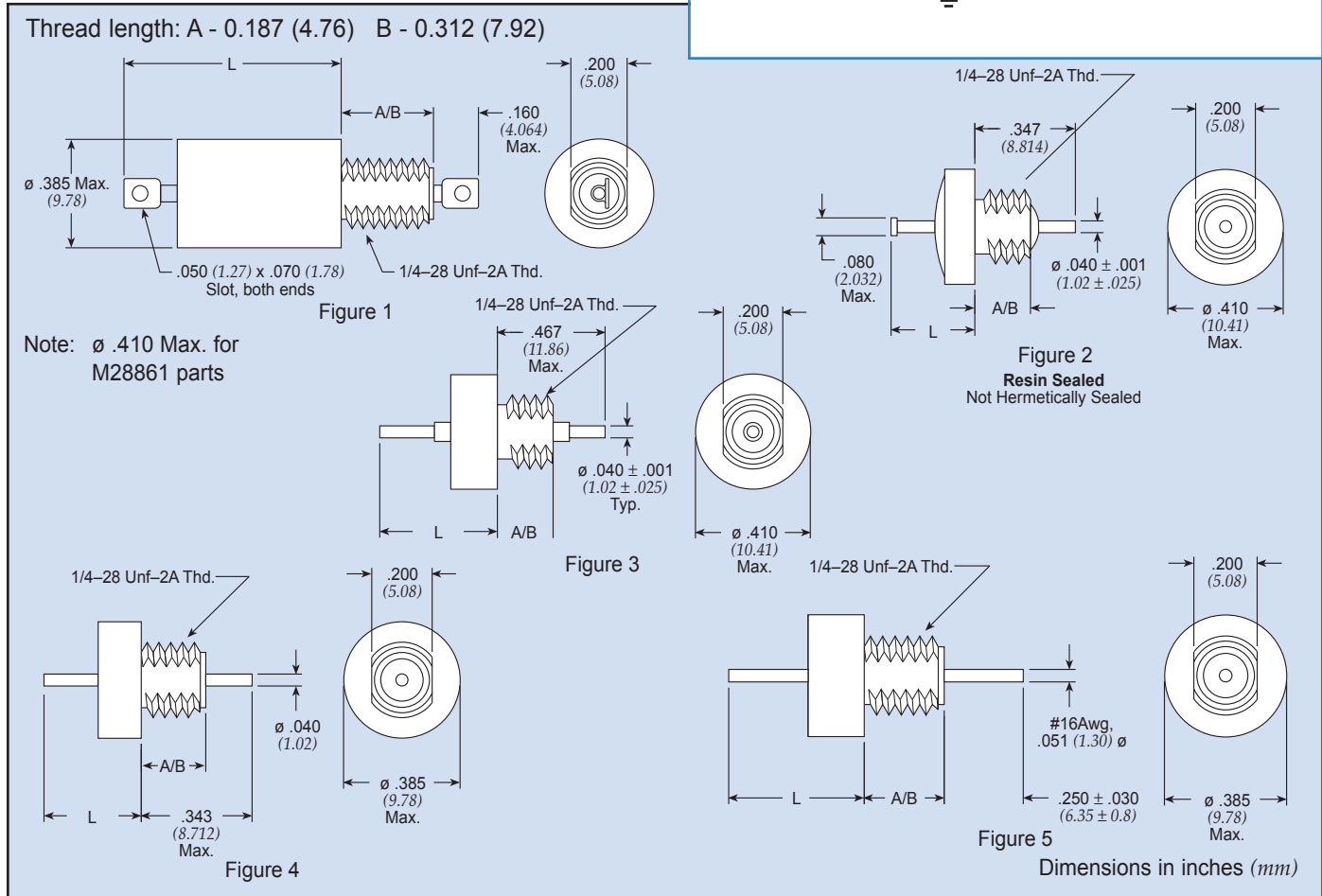

L-C Filter LT

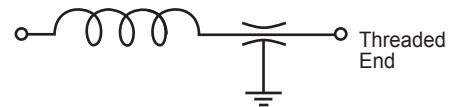

L-C Filter LB

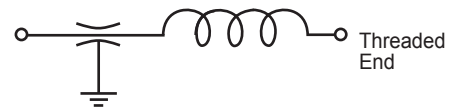

.375 ø L Standard Low Profile

| Part Number | MIL No | Figure | Rated Voltage | | | | I Amp | Min Cap µF | DCR Max Ohms | CKT | Max L In | Max L (mm) | Thd Lgth | Minimum Insertion Loss (dB) | | | | | | |
|-----------------|--------|------------------|---------------|---------|----------|----------|-------|------------|--------------|-----|----------|------------|----------|-----------------------------|---------|---------|-------|--------|---------|-------|
| | | | 85°C DC | 85°C AC | 125°C DC | 125°C AC | | | | | | | | 30 KHz | 150 KHz | 300 KHz | 1 MHz | 10 MHz | 100 MHz | 1 GHz |
| † 9051-100-0000 | — | 1 | 80 | — | 50 | — | 15 | 1.200 | 0.005 | LB | 0.370 | (9.398) | A | 15 | 25 | 34 | 44 | 60 | 70 | 70 |
| † 51-359-001 € | — | 1 | 80 | — | 50 | — | 15 | 1.400 | 0.005 | LB | 0.370 | (9.398) | A | 15 | 28 | 33 | 44 | 60 | 70 | 70 |
| SCI-1021-000 | — | 2* | 80 | — | 50 | — | 15 | 1.400 | 0.003 | LB | 0.280 | (7.112) | A | 15 | 28 | 33 | 44 | 60 | 70 | 70 |
| † 9053-100-0001 | — | 1 | 80 | — | 50 | — | 15 | 1.400 | 0.005 | LB | 0.370 | (9.398) | A | 15 | 25 | 34 | 44 | 60 | 70 | 70 |
| † 51-717-001 € | — | 2* | 80 | — | 50 | — | 15 | 1.400 | 0.005 | LB | 0.325 | (8.255) | A | 15 | 28 | 33 | 44 | 60 | 70 | 70 |
| 51-344-006 | — | 4 | 80 | — | 50 | — | 15 | 1.400 | 0.005 | LB | 0.330 | (8.382) | A | 15 | 28 | 33 | 44 | 60 | 70 | 70 |
| † SCI-1020-000 | — | 1 | 80 | — | 50 | — | 15 | 1.400 | 0.003 | LB | 0.370 | (9.398) | A | 15 | 28 | 33 | 44 | 60 | 70 | 70 |
| SCI-1021-020 | — | 2 ⁰ * | 80 | — | 50 | — | 15 | 1.400 | 0.003 | LB | 0.280 | (7.112) | B | 15 | 28 | 33 | 44 | 60 | 70 | 70 |
| † SCI-1020-020 | — | 1 | 80 | — | 50 | — | 15 | 1.400 | 0.003 | LB | 0.370 | (9.398) | B | 15 | 28 | 33 | 44 | 60 | 70 | 70 |
| SCI-1150-001 | — | 1 | 80 | — | 50 | — | 15 | 2.800 | 0.003 | LB | 0.450 | (11.430) | B | 20 | 34 | 40 | 49 | 60 | 70 | 70 |
| 9051-101-0018 | — | 5 | 80 | — | 50 | — | 25 | 1.400 | 0.001 | LB | 0.450 | (11.430) | A | 15 | 25 | 34 | 44 | 60 | 70 | 70 |
| † 9053-100-0008 | — | 1 | 100 | — | 70 | — | 15 | 0.700 | 0.005 | LB | 0.370 | (9.398) | A | 9 | 20 | 29 | 39 | 52 | 70 | 70 |

* Part is resin sealed, this is not a hermetic part.

† Also available through API's authorized distributors.

€ Also available through API's authorized European distributors/agents.

◇ Note: 0.462" (11.73mm) length from mounting surface to end of lead — not 0.347" (8.8mm).

Hermetically Sealed Threaded Case Filters

L-C Filter LT

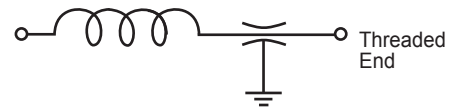

L-C Filter LB

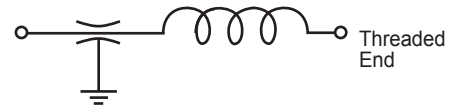

.375 ø L Standard Low Profile *continued*

| Part Number | MIL No | See Pg. LP28 for Fig | Rated Voltage | | | | I Amp | Min Cap µF | DCR Max Ohms | CKT | Max L | | Thd Lgth | Minimum Insertion Loss (dB) | | | | | | | |
|-----------------|--------|----------------------|---------------|-----|-------|-----|-------|------------|--------------|-----|-------|----------|----------|-----------------------------|---------|---------|-------|--------|---------|-------|--|
| | | | 85°C | | 125°C | | | | | | In | (mm) | | 30 KHz | 150 KHz | 300 KHz | 1 MHz | 10 MHz | 100 MHz | 1 GHz | |
| | | | DC | AC | DC | AC | | | | | | | | | | | | | | | |
| † 9050-100-0008 | — | 2* | 100 | — | 70 | — | 15 | 0.750 | 0.005 | LB | 0.325 | (8.255) | A | 9 | 20 | 29 | 39 | 52 | 70 | 70 | |
| † 9053-100-0002 | — | 1 | 150 | — | 100 | — | 15 | 0.500 | 0.005 | LB | 0.370 | (9.398) | A | 4 | 12 | 21 | 31 | 48 | 70 | 70 | |
| SCI-1250-001 | — | 1 | 150 | — | 100 | — | 15 | 0.500 | 0.003 | LB | 0.450 | (11.430) | B | 8 | 20 | 25 | 34 | 50 | 64 | 70 | |
| € SCI-2150-000 | — | 1 | 150 | — | 100 | — | 15 | 1.000 | 0.003 | LB | 0.450 | (11.430) | A | 10 | 25 | 30 | 41 | 56 | 70 | 70 | |
| SCI-2150-001 | — | 1 | 150 | — | 100 | — | 15 | 1.000 | 0.003 | LB | 0.450 | (11.430) | B | 10 | 25 | 30 | 41 | 56 | 70 | 70 | |
| † 51-717-007 | — | 2* | 250 | 125 | 200 | 125 | 15 | 0.015 | 0.005 | LB | 0.325 | (8.255) | A | — | — | — | 6 | 25 | 38 | 45 | |
| † 51-359-007 | — | 1 | 250 | 125 | 200 | 125 | 15 | 0.012 | 0.005 | LB | 0.370 | (9.398) | A | — | — | — | 6 | 25 | 38 | 50 | |
| 9050-100-0011 | — | 2 | 350 | 125 | 300 | 125 | 15 | 0.150 | 0.008 | LB | 0.325 | (8.255) | A | — | 10 | 15 | 25 | 40 | 52 | 60 | |
| € SCI-2350-000 | — | 1 | 300 | 125 | 300 | 125 | 15 | 0.250 | 0.003 | LB | 0.450 | (11.430) | A | 4 | 15 | 21 | 31 | 50 | 70 | 70 | |
| SCI-2350-001 | — | 1 | 300 | 125 | 300 | 125 | 15 | 0.250 | 0.003 | LB | 0.450 | (11.430) | B | 4 | 15 | 21 | 31 | 50 | 70 | 70 | |

* Part is resin sealed, this is not a hermetic part.

(See MIL index on pages CF9-11 for complete MIL part number listing)

.375 ø L Circuit MIL Qualified Low Profile

| Part Number | M15733 M28861 MIL No | See Pg. LP28 for Fig | Rated Voltage | | | | I Amp | Min Cap µF | DCR Max Ohms | CKT | Max L | | Thd Lgth | Minimum Insertion Loss (dB) | | | | | | | |
|--------------|----------------------|----------------------|---------------|----|-------|-----|-------|------------|--------------|-----|-------|----------|----------|-----------------------------|---------|---------|-------|--------|---------|-------|--|
| | | | 85°C | | 125°C | | | | | | In | (mm) | | 30 KHz | 150 KHz | 300 KHz | 1 MHz | 10 MHz | 100 MHz | 1 GHz | |
| | | | DC | AC | DC | AC | | | | | | | | | | | | | | | |
| † 51-359-021 | 38-0004 | 1 | — | — | 50 | — | 10 | 1.400 | 0.008 | LB | 0.370 | (9.398) | A | 15 | 28 | 33 | 44 | 60 | 70 | 70 | |
| † 51-359-024 | 38-0005 | 1 | 80 | — | 50 | — | 10 | 1.400 | 0.008 | LB | 0.370 | (9.398) | A | 15 | 28 | 33 | 44 | 60 | 70 | 70 | |
| † 51-359-051 | 58-0001 | 1 | 80 | — | 50 | — | 10 | 1.400 | 0.008 | LB | 0.545 | (13.843) | A | 15 | 28 | 33 | 44 | 60 | 70 | 70 | |
| 51-359-105 | 58-0004 | 1 | 80 | — | 50 | — | 10 | 1.400 | 0.008 | LT | 0.545 | (13.843) | B | 15 | 28 | 33 | 44 | 60 | 70 | 70 | |
| † 51-359-044 | 49-0006 | 1 | 100 | — | 50 | — | 15 | 1.200 | 0.010 | LB | 0.370 | (9.398) | A | 15 | 28 | 33 | 44 | 60 | 70 | 70 | |
| † 51-359-055 | 49-0007 | 3 | 100 | — | 50 | — | 15 | 1.200 | 0.010 | LB | 0.450 | (11.43) | A | 15 | 28 | 33 | 44 | 60 | 70 | 70 | |
| 51-359-081 | 1-001◇ | 1 | — | — | 50 | — | 15 | 1.400 | 0.008 | LB | 0.410 | (10.414) | A | 15 | 28 | 33 | 40 | 40 | 70 | 70 | |
| 51-359-086 | 1-011◇ | 1 | — | — | 50 | — | 15 | 1.400 | 0.008 | LB | 0.410 | (10.414) | B | 15 | 28 | 33 | 40 | 40 | 70 | 70 | |
| † 51-359-053 | 49-0001 | 4 | 100 | — | 50 | — | 15 | 0.680 | 0.010 | LB | 0.319 | (8.103) | A | 8 | 20 | 28 | 38 | 55 | 70 | 70 | |
| 51-359-082 | 1-003◇ | 1 | — | — | 70 | — | 15 | 0.700 | 0.008 | LB | 0.410 | (10.414) | A | 10 | 24 | 30 | 40 | 40 | 64 | 70 | |
| 51-359-083 | 1-005◇ | 1 | — | — | 100 | — | 15 | 0.450 | 0.008 | LB | 0.410 | (10.414) | A | 6 | 19 | 25 | 36 | 40 | 60 | 70 | |
| 51-359-088 | 1-015◇ | 1 | — | — | 100 | — | 15 | 0.450 | 0.008 | LB | 0.410 | (10.414) | B | 6 | 19 | 25 | 36 | 40 | 60 | 70 | |
| 51-359-084 | 1-007◇ | 1 | — | — | 150 | — | 15 | 0.250 | 0.008 | LB | 0.410 | (10.414) | A | — | 14 | 20 | 31 | 40 | 56 | 70 | |
| 51-359-050 | 38-0008 | 1 | — | — | 200 | 125 | 15 | 0.150 | 0.008 | LB | 0.370 | (9.398) | A | — | — | — | 6 | 25 | 42 | 60 | |
| 51-359-085 | 1-009◇ | 1 | — | — | 200 | 125 | 15 | 0.150 | 0.008 | LB | 0.410 | (10.414) | A | — | 10 | 16 | 26 | 40 | 52 | 70 | |
| 51-359-090 | 1-019◇ | 1 | — | — | 200 | 125 | 15 | 0.150 | 0.008 | LB | 0.410 | (10.414) | B | — | 10 | 16 | 26 | 40 | 52 | 70 | |

† Also available through API's authorized distributors.

€ Also available through API's authorized European distributors/agents.

Hermetically Sealed Threaded Case Filters

.375 ø L Circuit

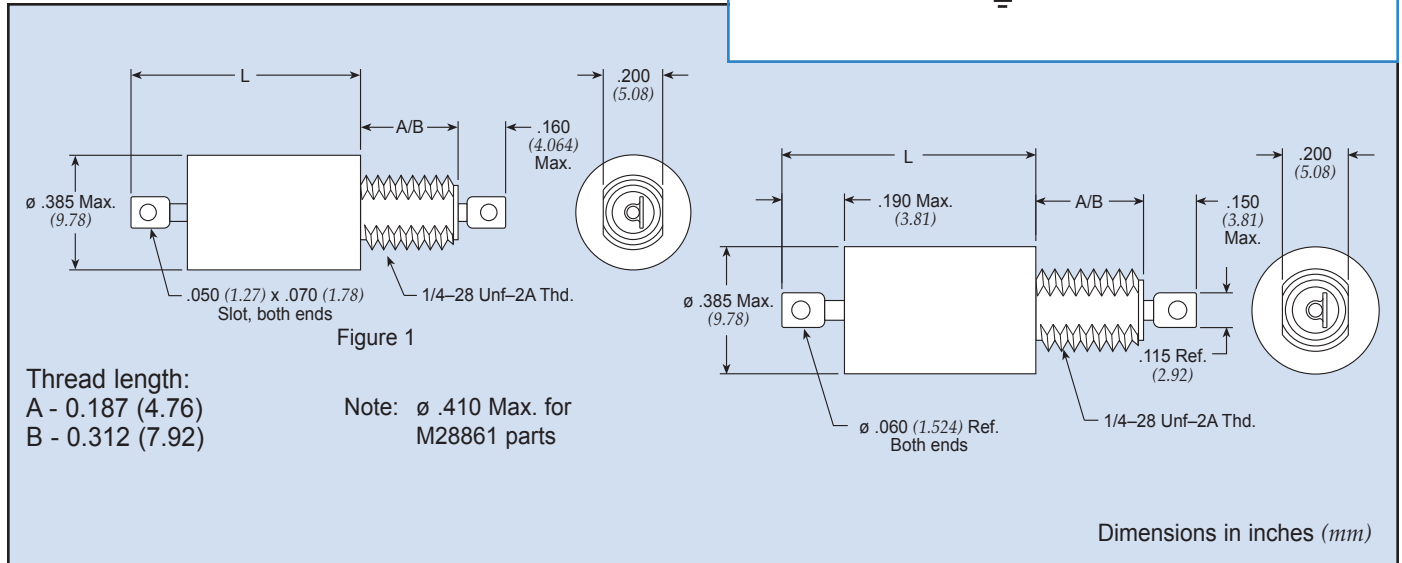

.375 ø L Circuit Standard Product

| Part Number | MIL No | Figure | Rated Voltage | | | | I Amp | Min Cap µF | DCR Max Ohms | CKT | Max L In | Max L (mm) | Thd Lgth | Minimum Insertion Loss (dB) | | | | | | |
|-----------------|--------|--------|---------------|----|-------|----|-------|------------|--------------|-----|----------------|------------|----------|-----------------------------|---------|---------|-------|--------|---------|-------|
| | | | 85°C | | 125°C | | | | | | | | | 30 KHz | 150 KHz | 300 KHz | 1 MHz | 10 MHz | 100 MHz | 1 GHz |
| | | | DC | AC | DC | AC | | | | | | | | | | | | | | |
| 51-353-007 | — | 1 | 80 | — | 50 | — | 0.06 | 1.400 | 70.000 | LB | 0.770 (19.558) | A | 44 | 70 | 70 | 70 | 70 | 70 | 70 | |
| 51-353-095 | — | 1 | 80 | — | 50 | — | 0.15 | 1.400 | 12.000 | LT | 0.960 (24.384) | A | 21 | 52 | 64 | 70 | 70 | 70 | 70 | |
| 51-353-003 | — | 1 | 80 | — | 50 | — | 0.45 | 1.400 | 1.200 | LB | 0.770 (19.558) | A | 16 | 31 | 37 | 55 | 70 | 70 | 70 | |
| 51-353-099 | — | 1 | 80 | — | 50 | — | 1.00 | 1.400 | 0.250 | LT | 0.770 (19.558) | A | 16 | 33 | 44 | 70 | 70 | 70 | 70 | |
| 51-353-100 | — | 1 | 80 | — | 50 | — | 5.00 | 1.400 | 0.015 | LT | 0.770 (19.558) | A | 15 | 28 | 33 | 46 | 70 | 70 | 70 | |
| † 9200-300-0025 | — | 1 | 80 | — | 50 | — | 10.00 | 1.200 | 0.010 | LB | 0.450 (11.430) | A | 15 | 28 | 33 | 44 | 60 | 70 | 70 | |

† Also available through API's authorized distributors.

Hermetically Sealed Threaded Case Filters

L-C Filter LT

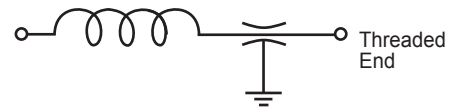

L-C Filter LB

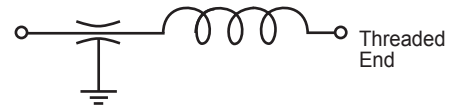

.375 ø L Circuit Standard Product *continued*

| Part Number | MIL No | See Pg. LP30 for Fig | Rated Voltage | | | | I Amp | Min Cap µF | DCR Max Ohms | CKT | Max L | | Thd Lgth | Minimum Insertion Loss (dB) | | | | | | |
|-----------------|--------|----------------------|---------------|----|-------|-----|-------|------------|--------------|-----|-------|----------|----------|-----------------------------|---------|---------|-------|--------|---------|-------|
| | | | 85°C | | 125°C | | | | | | In | (mm) | | 30 KHz | 150 KHz | 300 KHz | 1 MHz | 10 MHz | 100 MHz | 1 GHz |
| | | | DC | AC | DC | AC | | | | | | | | | | | | | | |
| † 9200-303-0095 | — | 1 | 80 | — | 50 | — | 10.00 | 1.200 | 0.010 | LB | 0.450 | (11.430) | B | 15 | 28 | 33 | 44 | 60 | 70 | 70 |
| 51-353-101 | — | 1 | 80 | — | 50 | — | 10.00 | 1.400 | 0.010 | LT | 0.450 | (11.430) | A | 14 | 28 | 33 | 44 | 60 | 70 | 70 |
| 51-353-109 | — | 1 | 80 | — | 50 | — | 10.00 | 1.400 | 0.010 | LT | 0.450 | (11.430) | B | 15 | 28 | 33 | 44 | 60 | 70 | 70 |
| 51-353-120 | — | 1 | 150 | — | 100 | — | 1.00 | 0.750 | 0.250 | LB | 0.758 | (19.253) | A | 9 | 27 | 36 | 57 | 70 | 70 | 70 |
| 9000-103-0019 | — | 1 | 150 | — | 100 | — | 5.00 | 0.450 | 0.015 | LT | 0.758 | (19.253) | B | 6 | 20 | 26 | 37 | 68 | 70 | 70 |
| SCI-2120-014 | — | 1 | 150 | — | 100 | — | 10.00 | 1.000 | 0.003 | LB | 0.450 | (11.430) | B | 14 | 28 | 34 | 44 | 52 | 70 | 70 |
| 51-353-110 | — | 1 | 250 | — | 200 | 125 | 1.00 | 0.250 | 0.250 | LT | 0.758 | (19.253) | A | — | 17 | 29 | 50 | 70 | 70 | 70 |
| † 51-353-111 | — | 1 | 250 | — | 200 | 125 | 1.00 | 0.250 | 0.250 | LB | 0.758 | (19.253) | A | — | 17 | 29 | 50 | 70 | 70 | 70 |
| 51-353-112 | — | 1 | 250 | — | 200 | 125 | 3.00 | 0.250 | 0.050 | LT | 0.758 | (19.253) | A | — | 13 | 20 | 35 | 70 | 70 | 70 |
| † 51-353-113 | — | 1 | 250 | — | 200 | 125 | 3.00 | 0.250 | 0.050 | LB | 0.758 | (19.253) | A | — | 13 | 20 | 35 | 70 | 70 | 70 |
| 51-353-114 | — | 1 | 250 | — | 200 | 125 | 5.00 | 0.250 | 0.015 | LT | 0.758 | (19.253) | A | — | 12 | 20 | 30 | 62 | 70 | 70 |
| 51-353-116 | — | 1 | 250 | — | 200 | 125 | 10.00 | 0.250 | 0.010 | LT | 0.450 | (11.430) | A | — | 15 | 20 | 30 | 50 | 70 | 70 |
| SCI-2320-010 | — | 1 | 300 | — | 300 | 125 | 0.50 | 0.150 | 1.000 | LB | 0.758 | (19.253) | B | — | 23 | 35 | 56 | 70 | 70 | 70 |
| SCI-2320-004 | — | 1 | 300 | — | 300 | 125 | 1.00 | 0.150 | 0.250 | LB | 0.758 | (19.253) | A | — | 10 | 21 | 41 | 70 | 70 | 70 |
| SCI-2320-005 | — | 1 | 300 | — | 300 | 125 | 2.00 | 0.150 | 0.063 | LB | 0.758 | (19.253) | A | — | 8 | 14 | 30 | 70 | 70 | 70 |
| SCI-2320-006 | — | 1 | 300 | — | 300 | 125 | 3.00 | 0.150 | 0.027 | LB | 0.758 | (19.253) | A | — | 8 | 14 | 26 | 64 | 70 | 70 |
| SCI-2320-007 | — | 1 | 300 | — | 300 | 125 | 10.00 | 0.150 | 0.003 | LB | 0.450 | (11.430) | A | — | 8 | 14 | 25 | 45 | 52 | 70 |
| SCI-2320-014 | — | 1 | 300 | — | 300 | 125 | 10.00 | 0.150 | 0.003 | LB | 0.450 | (11.430) | B | — | 8 | 14 | 25 | 45 | 52 | 70 |

(See MIL index on pages CF9-11 for complete MIL part number listing)

.375 ø L Circuit MIL Qualified Profile

| Part Number | M15733 MIL No | See Pg. LP30 for Fig | Rated Voltage | | | | I Amp | Min Cap µF | DCR Max Ohms | CKT | Max L | | Thd Lgth | Minimum Insertion Loss (dB) | | | | | | |
|--------------|---------------|----------------------|---------------|----|-------|----|-------|------------|--------------|-----|-------|----------|----------|-----------------------------|---------|---------|-------|--------|---------|-------|
| | | | 85°C | | 125°C | | | | | | In | (mm) | | 30 KHz | 150 KHz | 300 KHz | 1 MHz | 10 MHz | 100 MHz | 1 GHz |
| | | | DC | AC | DC | AC | | | | | | | | | | | | | | |
| 51-390-018 | 23-0026 | 1 | — | — | 50 | — | 0.50 | 1.400 | 0.360 | LB | 0.630 | (16.002) | A | 12 | 36 | 48 | 69 | 70 | 70 | 70 |
| 51-390-026 | 23-0038 | 1 | — | — | 50 | — | 1.00 | 1.400 | 0.140 | LB | 0.630 | (16.002) | A | 11 | 26 | 36 | 55 | 70 | 70 | 70 |
| 51-390-034 | 23-0050 | 1 | — | — | 50 | — | 2.00 | 1.400 | 0.070 | LB | 0.630 | (16.002) | A | 10 | 24 | 32 | 48 | 70 | 70 | 70 |
| † 51-353-067 | 24-0006 | 1 | 80 | — | 50 | — | 10.00 | 1.400 | 0.010 | LB | 0.760 | (19.304) | B | 15 | 28 | 31 | 42 | 56 | 70 | 70 |
| 51-353-207 | 34-0007 | 1 | — | — | 50 | — | 10.00 | 1.400 | 0.010 | LB | 0.760 | (19.304) | A | 15 | 28 | 31 | 42 | 56 | 70 | 70 |
| 51-444-072 | 58-0002 | 1 | 80 | — | 50 | — | 10.00 | 1.400 | 0.008 | LT | 0.545 | (13.843) | A | 15 | 28 | 33 | 44 | 60 | 70 | 70 |
| † 51-353-066 | 24-0005 | 1 | 80 | — | 50 | — | 10.00 | 1.400 | 0.010 | LB | 0.760 | (19.304) | A | 15 | 28 | 31 | 42 | 56 | 70 | 70 |
| 51-353-287 | 39-0014 | 1 | — | — | 50 | — | 10.00 | 1.400 | 0.003 | LT | 0.760 | (19.304) | B | 14 | 28 | 34 | 44 | 52 | 70 | 70 |
| † 51-444-060 | 24-0008 | 1 | 80 | — | 50 | — | 10.00 | 1.400 | 0.010 | LT | 0.740 | (18.796) | B | 15 | 28 | 31 | 42 | 56 | 70 | 70 |
| † 51-343-028 | 38-0002 | 1 | — | — | 50 | — | 15.00 | 1.400 | 0.008 | LB | 0.481 | (12.217) | A | 15 | 28 | 33 | 44 | 64 | 70 | 70 |
| † 51-343-034 | 38-0006 | 1 | — | — | 50 | — | 15.00 | 1.400 | 0.008 | LB | 0.481 | (12.217) | B | 15 | 28 | 33 | 44 | 64 | 70 | 70 |
| 51-353-053 | 25-0003 | 1 | — | — | 100 | — | 1.00 | 0.450 | 0.250 | LB | 0.738 | (18.745) | A | 6 | 23 | 34 | 55 | 70 | 70 | 70 |
| † 51-353-054 | 25-0005 | 1 | — | — | 100 | — | 5.00 | 0.450 | 0.015 | LT | 0.758 | (19.253) | A | 6 | 17 | 23 | 35 | 69 | 70 | 70 |
| † 51-353-055 | 25-0008 | 1 | — | — | 100 | — | 5.00 | 0.450 | 0.015 | LB | 0.738 | (18.745) | A | 6 | 17 | 23 | 35 | 69 | 70 | 70 |
| 51-353-155 | 39-0008 | 1 | — | — | 100 | — | 5.00 | 0.450 | 0.015 | LB | 0.760 | (19.304) | A | 6 | 20 | 26 | 35 | 60 | 60 | 70 |
| 51-444-039 | 25-0017 | 1 | — | — | 100 | — | 5.00 | 0.450 | 0.015 | LT | 0.758 | (19.253) | B | 6 | 17 | 23 | 35 | 69 | 70 | 70 |

† Also available through API's authorized distributors.

Hermetically Sealed Threaded Case Filters

L-C Filter LT

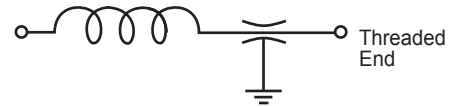

L-C Filter LB

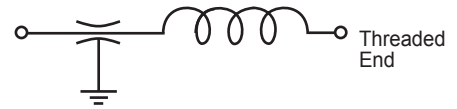

.375 ø L Circuit MIL Qualified Profile *continued*

(See MIL index on pages CF9-11 for complete MIL part number listing)

| Part Number | M15733 MIL No | See Pg. LP30 for Fig | Rated Voltage | | | | I Amp | Min Cap µF | DCR Max Ohms | CKT | Max L In (mm) | Thd Lgth | Minimum Insertion Loss (dB) | | | | | | | |
|--------------|---------------|----------------------|---------------|----|-------|-----|-------|------------|--------------|-----|----------------|----------|-----------------------------|---------|---------|-------|--------|---------|-------|--|
| | | | 85°C | | 125°C | | | | | | | | 30 KHz | 150 KHz | 300 KHz | 1 MHz | 10 MHz | 100 MHz | 1 GHz | |
| | | | DC | AC | DC | AC | | | | | | | | | | | | | | |
| 51-444-040 | 25-0020 | 1 | — | — | 100 | | 5.00 | 0.450 | 0.015 | LB | 0.738 (18.745) | B | 6 | 17 | 23 | 35 | 69 | 70 | 70 | |
| 51-353-156 | 39-0009 | 1 | — | — | 100 | | 10.00 | 0.450 | 0.003 | LT | 0.760 (19.304) | A | 6 | 20 | 26 | 35 | 56 | 60 | 70 | |
| 51-353-157 | 39-0010 | 1 | — | — | 100 | | 10.00 | 0.450 | 0.003 | LB | 0.760 (19.304) | A | 6 | 20 | 26 | 35 | 56 | 60 | 70 | |
| + 51-353-076 | 26-0001 | 1 | — | — | 150 | 125 | 1.00 | 0.250 | 0.250 | LT | 0.758 (19.253) | A | — | 13 | 24 | 45 | 80 | 70 | 70 | |
| + 51-353-077 | 26-0003 | 1 | — | — | 150 | 125 | 1.00 | 0.250 | 0.250 | LB | 0.738 (18.745) | A | — | 13 | 24 | 45 | 80 | 70 | 70 | |
| 51-444-043 | 26-0013 | 1 | — | — | 150 | 125 | 1.00 | 0.250 | 0.250 | LT | 0.758 (19.253) | B | — | 13 | 24 | 45 | 80 | 70 | 70 | |
| 51-444-044 | 26-0015 | 1 | — | — | 150 | 125 | 1.00 | 0.250 | 0.250 | LB | 0.738 (18.745) | B | — | 13 | 24 | 45 | 80 | 70 | 70 | |
| 51-390-040 | 23-0058 | 1 | — | — | 150 | | 2.00 | 0.250 | 0.070 | LT | 0.630 (16.002) | A | 3 | 15 | 23 | 38 | 60 | 70 | 60 | |
| 51-390-039 | 23-0057 | 1 | — | — | 150 | | 2.00 | 0.250 | 0.070 | LT | 0.630 (16.002) | B | 3 | 15 | 23 | 38 | 60 | 70 | 60 | |
| 51-444-005 | 34-0015 | 1 | — | — | 150 | 125 | 3.00 | 0.150 | 0.050 | LT | 0.758 (19.253) | B | — | 8 | 15 | 30 | 68 | 70 | 70 | |
| + 51-353-078 | 26-0004 | 1 | — | — | 150 | 125 | 3.00 | 0.250 | 0.050 | LT | 0.758 (19.253) | A | — | 8 | 15 | 30 | 68 | 70 | 70 | |
| + 51-353-079 | 26-0006 | 1 | — | — | 150 | 125 | 3.00 | 0.250 | 0.050 | LB | 0.738 (18.745) | A | — | 8 | 15 | 30 | 68 | 70 | 70 | |
| + 51-444-046 | 26-0018 | 1 | — | — | 150 | 125 | 3.00 | 0.250 | 0.050 | LB | 0.738 (18.745) | B | — | 8 | 15 | 30 | 68 | 70 | 70 | |
| 51-444-047 | 26-0019 | 1 | — | — | 150 | 125 | 5.00 | 0.250 | 0.015 | LT | 0.758 (19.253) | B | — | 8 | 14 | 25 | 58 | 70 | 70 | |
| + 51-353-080 | 26-0007 | 1 | — | — | 150 | 125 | 5.00 | 0.250 | 0.015 | LT | 0.758 (19.253) | A | — | 8 | 14 | 25 | 58 | 70 | 70 | |
| 51-353-081 | 26-0010 | 1 | — | — | 150 | 125 | 5.00 | 0.250 | 0.015 | LB | 0.738 (18.745) | A | — | 8 | 14 | 25 | 58 | 70 | 70 | |
| 51-444-027 | 34-0030 | 1 | — | — | 200 | 125 | 5.00 | 0.250 | 0.150 | LB | 0.900 (22.860) | A | 2 | 15 | 21 | 32 | 60 | 70 | 70 | |
| 51-444-117 | 54-0018 | 2 | — | — | 300 | 125 | 1.00 | 0.150 | 0.250 | LB | 0.740 (18.796) | A | — | 10 | 21 | 41 | 70 | 70 | 70 | |

† Also available through API's authorized distributors.

Hermetically Sealed Threaded Case Filters



.375 ø Pi Circuit

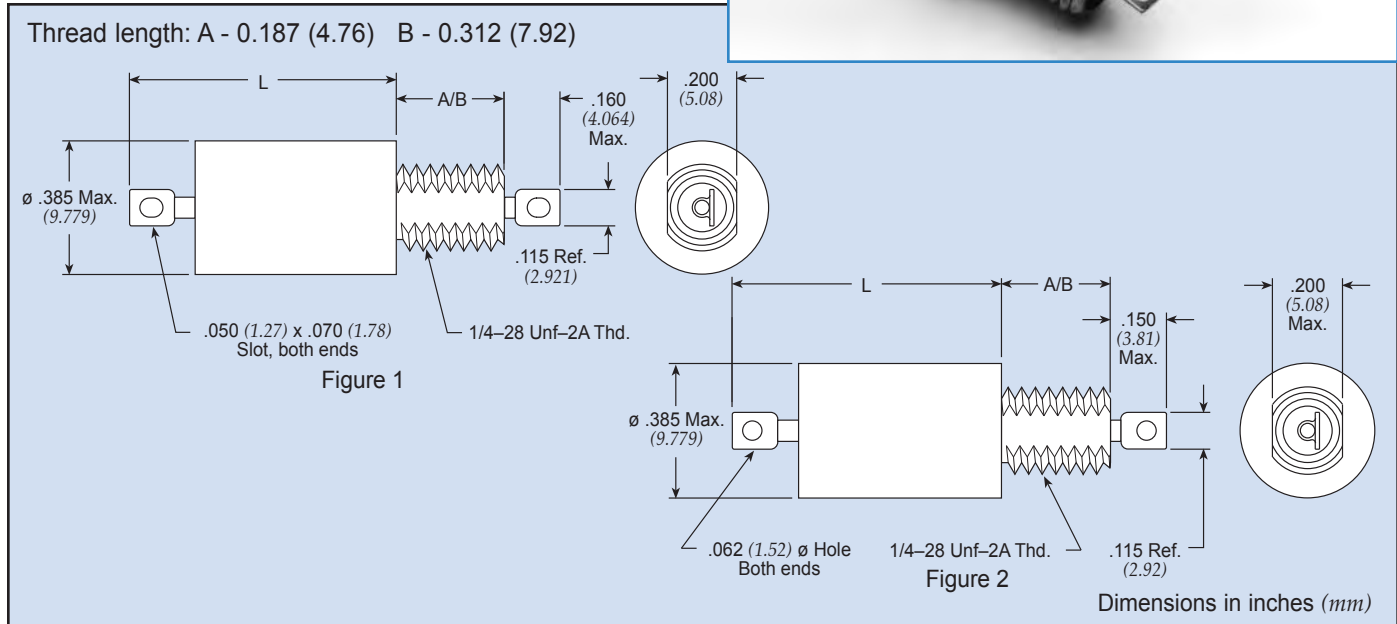

.375 ø Pi Circuit Standard Product

| Part Number | MIL No | Figure | Rated Voltage | | | | I Amp | Min Cap µF | DCR Max Ohms | Max L | | Thd Lgth | Minimum Insertion Loss (dB) | | | | | | |
|----------------|--------|--------|---------------|-----|-------|-----|-------|------------|--------------|-------|----------|----------|-----------------------------|---------|---------|-------|--------|---------|-------|
| | | | 85°C | | 125°C | | | | | In | (mm) | | 30 KHz | 150 KHz | 300 KHz | 1 MHz | 10 MHz | 100 MHz | 1 GHz |
| | | | DC | AC | DC | AC | | | | | | | | | | | | | |
| SCI-2030-010 | — | 2 | 80 | — | 50 | — | 0.50 | 1.500 | 1.000 | 0.758 | (19.253) | B | 24 | 66 | 70 | 70 | 70 | 70 | |
| SCI-2030-004 | — | 2 | 80 | — | 50 | — | 1.00 | 1.500 | 0.250 | 0.758 | (19.253) | A | 15 | 54 | 70 | 70 | 70 | 70 | |
| SCI-2030-005 | — | 2 | 80 | — | 50 | — | 2.00 | 1.500 | 0.063 | 0.758 | (19.253) | A | — | 45 | 62 | 70 | 70 | 70 | |
| SCI-2030-006 | — | 2 | 80 | — | 50 | — | 3.00 | 1.500 | 0.027 | 0.758 | (19.253) | A | — | 35 | 55 | 70 | 70 | 70 | |
| SCI-2030-013 | — | 2 | 80 | — | 50 | — | 3.00 | 1.500 | 0.027 | 0.758 | (19.253) | B | — | 35 | 55 | 70 | 70 | 70 | |
| †9001-100-1080 | — | 1 | 80 | — | 50 | — | 5.00 | 2.800 | 0.015 | 0.758 | (19.253) | A | — | 18 | 60 | 70 | 70 | 70 | |
| †9001-100-1081 | — | 1 | 80 | — | 50 | — | 10.0 | 2.800 | 0.005 | 0.758 | (19.253) | A | 21 | 32 | 40 | 35 | 68 | 70 | |
| SCI-2130-009 | — | 1 | 150 | — | 100 | — | 0.25 | 1.000 | 4.000 | 0.758 | (19.253) | B | 28 | 70 | 70 | 70 | 70 | 70 | |
| 51-311-319 | — | 1 | 150 | — | 100 | — | 0.50 | 1.000 | 0.600 | 0.758 | (19.253) | A | — | 51 | 69 | 70 | 70 | 70 | |
| †9001-100-1010 | — | 1 | 150 | — | 100 | — | 0.50 | 1.000 | 0.600 | 0.758 | (19.253) | A | 6 | 39 | 68 | 70 | 70 | 70 | |
| 51-311-320 | — | 1 | 150 | — | 100 | — | 1.00 | 1.000 | 0.250 | 0.758 | (19.253) | A | — | 41 | 60 | 70 | 70 | 70 | |
| †9001-100-1013 | — | 1 | 150 | — | 100 | — | 1.00 | 1.000 | 0.250 | 0.758 | (19.253) | A | — | 28 | 59 | 70 | 70 | 70 | |
| 51-311-321 | — | 1 | 150 | — | 100 | — | 3.00 | 1.000 | 0.060 | 0.758 | (19.253) | A | — | 16 | 41 | 70 | 70 | 70 | |
| †51-311-322 | — | 1 | 150 | — | 100 | — | 5.00 | 1.000 | 0.015 | 0.758 | (19.253) | A | — | — | 28 | 65 | 70 | 70 | |
| SCI-2130-007 | — | 1 | 150 | — | 100 | — | 10.0 | 1.000 | 0.003 | 0.758 | (19.253) | A | 9 | 24 | 29 | 40 | 70 | 70 | |
| SCI-2130-014 | — | 1 | 150 | — | 100 | — | 10.0 | 1.000 | 0.005 | 0.758 | (19.253) | B | 9 | 24 | 29 | 40 | 70 | 70 | |
| 51-311-316 | — | 1 | 250 | 125 | 200 | 125 | 1.00 | 0.300 | 0.250 | 0.758 | (19.253) | A | — | 20 | 40 | 70 | 70 | 70 | |
| 51-311-317 | — | 1 | 250 | 125 | 200 | 125 | 3.00 | 0.300 | 0.050 | 0.758 | (19.253) | A | — | — | 20 | 55 | 70 | 70 | |
| †9001-100-1025 | — | 1 | 250 | 125 | 200 | 125 | 5.00 | 0.300 | 0.015 | 0.758 | (19.253) | A | — | — | 12 | 50 | 70 | 70 | |
| SCI-2330-009 | — | 1 | 300 | 125 | 300 | 125 | 0.25 | 0.300 | 4.000 | 0.758 | (19.253) | B | 8 | 50 | 66 | 70 | 70 | 70 | |
| SCI-2330-010 | — | 1 | 300 | 125 | 300 | 125 | 0.50 | 0.300 | 1.000 | 0.758 | (19.253) | B | — | 40 | 56 | 70 | 70 | 70 | |
| SCI-2330-012 | — | 1 | 300 | 125 | 300 | 125 | 2.00 | 0.300 | 0.063 | 0.758 | (19.253) | B | — | 18 | 33 | 63 | 70 | 70 | |
| SCI-2330-007 | — | 1 | 300 | 125 | 300 | 125 | 10.0 | 0.300 | 0.003 | 0.758 | (19.253) | A | — | 14 | 20 | 30 | 70 | 70 | |

† Also available through API's authorized distributors.

Hermetically Sealed Threaded Case Filters

.375 ø Pi Circuit MIL Qualified Product

(See MIL index on pages CF9-11 for complete MIL part number listing)

| Part Number | M15733 MIL No | See Pg. LP33 for Fig. | Rated Voltage | | | | I Amp | Min Cap µF | DCR Max Ohms | Max L | | Thd Lgth | Minimum Insertion Loss (dB) | | | | | | |
|--------------|---------------|-----------------------|---------------|----|-------|-----|-------|------------|--------------|-------|----------|----------|-----------------------------|---------|---------|-------|--------|---------|-------|
| | | | 85°C | | 125°C | | | | | In | (mm) | | 30 KHz | 150 KHz | 300 KHz | 1 MHz | 10 MHz | 100 MHz | 1 GHz |
| | | | DC | AC | DC | AC | | | | | | | | | | | | | |
| 51-390-305 | 23-0017 | 1 | — | — | 50 | — | 0.30 | 2.800 | 0.770 | 0.730 | (18.542) | B | 29 | 73 | 80 | 80 | 80 | 80 | |
| 51-390-314 | 23-0042 | 1 | — | — | 50 | — | 1.00 | 2.800 | 0.140 | 0.730 | (18.542) | A | 8 | 52 | 71 | 80 | 80 | 80 | 80 |
| † 51-390-318 | 23-0054 | 1 | — | — | 50 | — | 2.00 | 1.500 | 0.070 | 0.730 | (18.542) | A | — | 46 | 65 | 80 | 80 | 80 | 80 |
| † 51-390-317 | 23-0053 | 1 | — | — | 50 | — | 2.00 | 1.500 | 0.070 | 0.730 | (18.542) | B | — | 46 | 65 | 80 | 80 | 80 | 80 |
| 51-311-311 | 25-0010 | 1 | — | — | 100 | — | 0.25 | 0.900 | 1.500 | 0.793 | (20.142) | A | — | 48 | 66 | 80 | 80 | 80 | 70 |
| † 51-311-308 | 25-0002 | 1 | — | — | 100 | — | 1.00 | 0.500 | 0.250 | 0.793 | (20.142) | A | — | 33 | 52 | 80 | 80 | 80 | 70 |
| † 51-311-309 | 25-0004 | 1 | — | — | 100 | — | 3.00 | 0.660 | 0.050 | 0.793 | (20.142) | A | — | 17 | 34 | 68 | 80 | 80 | 70 |
| † 51-311-310 | 25-0006 | 1 | — | — | 100 | — | 5.00 | 0.900 | 0.015 | 0.793 | (20.142) | A | — | — | 17 | 57 | 80 | 80 | 70 |
| 51-353-344 | 39-0011 | 1 | — | — | 100 | — | 10.0 | 0.990 | 0.003 | 0.760 | (19.304) | A | 9 | 24 | 29 | 40 | 70 | 70 | 70 |
| 51-353-345 | 39-0012 | 1 | — | — | 100 | — | 10.0 | 0.990 | 0.003 | 0.760 | (19.304) | A | 9 | 24 | 29 | 40 | 70 | 70 | 70 |
| † 51-311-314 | 26-0011 | 1 | — | — | 150 | 125 | 0.25 | 0.300 | 1.500 | 0.793 | (20.142) | A | — | 29 | 47 | 70 | 80 | 80 | 70 |
| 51-390-312 | 23-0036 | 1 | — | — | 150 | — | 0.50 | 0.500 | 0.360 | 0.730 | (18.542) | A | — | 48 | 66 | 70 | 70 | 70 | 70 |
| 51-390-311 | 23-0035 | 1 | — | — | 150 | — | 0.50 | 0.500 | 0.360 | 0.730 | (18.542) | B | — | 48 | 66 | 70 | 70 | 70 | 70 |
| † 51-353-336 | 26-0002 | 1 | — | — | 150 | 125 | 1.00 | 0.300 | 0.250 | 0.793 | (20.142) | A | — | 11 | 32 | 63 | 80 | 80 | 70 |
| 51-390-315 | 23-0047 | 1 | — | — | 150 | — | 1.00 | 0.500 | 0.140 | 0.730 | (18.542) | B | — | 32 | 51 | 70 | 70 | 70 | 70 |
| 51-311-312 | 26-0005 | 1 | — | — | 150 | 125 | 3.00 | 0.300 | 0.050 | 0.793 | (20.142) | A | — | 5 | 6 | 47 | 80 | 80 | 70 |
| 51-311-408 | 54-0005 | 2 | — | — | 300 | 115 | 1.00 | 0.300 | 0.250 | 0.761 | (19.329) | A | — | 23 | 43 | 70 | 70 | 70 | 70 |

† Also available through API's authorized distributors.

Transient Suppression Pi Filters

| Part Number | See Pg. LP33 for Fig. | Rated Volt. VDC | I Amp | Min Cap µF | DCR Min Mohms | Max RDC Ohms | Transient Suppressor* | | | | Length | | Max Thd Lgth | Minimum Insertion Loss (dB) | | | | | | |
|-------------|-----------------------|-----------------|-------|------------|---------------|--------------|-----------------------|-----------|----------|----------|--------|----------|--------------|-----------------------------|---------|-------|--------|---------|-------|--|
| | | | | | | | VR* (VDC) | BV* (VDC) | IT* (MA) | IPP* (A) | In | (mm) | | 30 KHz | 300 KHz | 1 MHz | 10 MHz | 100 MHz | 1 GHz | |
| | | | | | | | | | | | | | | | | | | | | |
| 51-570-300 | 1 | 5 | 0.50 | 1.400 | 0.500 | 0.600 | 6.5 | 7.22/7.98 | 10 | 44.7 | 1.179 | (29.947) | A | 23 | 57 | 70 | 70 | 70 | 70 | |
| 51-570-301 | 1 | 5 | 1.00 | 1.400 | 0.500 | 0.350 | 6.5 | 7.22/7.98 | 10 | 44.7 | 1.179 | (29.947) | A | 3 | 47 | 70 | 70 | 70 | 70 | |
| 51-570-302 | 1 | 5 | 3.00 | 1.400 | 0.500 | 0.060 | 6.5 | 7.22/7.98 | 10 | 44.7 | 1.179 | (29.947) | A | — | 23 | 58 | 70 | 70 | 70 | |
| 51-570-303 | 1 | 5 | 5.00 | 1.400 | 0.500 | 0.015 | 6.5 | 7.22/7.98 | 10 | 44.7 | 1.179 | (29.947) | A | — | 17 | 48 | 70 | 70 | 70 | |
| 51-570-304 | 1 | 5 | 10.00 | 1.400 | 0.500 | 0.005 | 6.5 | 7.22/7.98 | 10 | 44.7 | 1.179 | (29.947) | A | 16 | 26 | 35 | 40 | 60 | 70 | |
| 51-570-310 | 1 | 28 | 0.50 | 1.400 | 30.000 | 0.600 | 33.0 | 36.7/40.6 | 1 | 9.4 | 1.179 | (29.947) | A | 23 | 57 | 70 | 70 | 70 | 70 | |
| 51-570-311 | 1 | 28 | 1.00 | 1.400 | 30.000 | 0.350 | 33.0 | 36.7/40.6 | 1 | 9.4 | 1.179 | (29.947) | A | 3 | 47 | 70 | 70 | 70 | 70 | |
| 51-570-312 | 1 | 28 | 3.00 | 1.400 | 30.000 | 0.060 | 33.0 | 36.7/40.6 | 1 | 9.4 | 1.179 | (29.947) | A | — | 23 | 58 | 70 | 70 | 70 | |
| 51-570-313 | 1 | 28 | 5.00 | 1.400 | 30.000 | 0.015 | 33.0 | 36.7/40.6 | 1 | 9.4 | 1.179 | (29.947) | A | — | 17 | 48 | 70 | 70 | 70 | |
| 51-570-314 | 1 | 28 | 10.00 | 1.400 | 30.000 | 0.005 | 33.0 | 36.7/40.6 | 1 | 9.4 | 1.179 | (29.947) | A | 16 | 26 | 35 | 40 | 60 | 70 | |
| 51-570-320 | 1 | 50 | 0.50 | 1.400 | 50.000 | 0.600 | 58.0 | 64.4/71.2 | 1 | 5.3 | 1.179 | (29.947) | A | 23 | 57 | 70 | 70 | 70 | 70 | |
| 51-570-321 | 1 | 50 | 1.00 | 1.400 | 50.000 | 0.350 | 58.0 | 64.4/71.2 | 1 | 5.3 | 1.179 | (29.947) | A | 3 | 47 | 70 | 70 | 70 | 70 | |
| 51-570-322 | 1 | 50 | 3.00 | 1.400 | 50.000 | 0.060 | 58.0 | 64.4/71.2 | 1 | 5.3 | 1.179 | (29.947) | A | — | 23 | 58 | 70 | 70 | 70 | |
| 51-570-323 | 1 | 50 | 5.00 | 1.400 | 50.000 | 0.015 | 58.0 | 64.4/71.2 | 1 | 5.3 | 1.179 | (29.947) | A | — | 17 | 48 | 70 | 70 | 70 | |
| 51-570-324 | 1 | 50 | 10.00 | 1.400 | 50.000 | 0.005 | 58.0 | 64.4/71.2 | 1 | 5.3 | 1.179 | (29.947) | A | 16 | 26 | 35 | 40 | 60 | 70 | |

* Transient Suppression definitions and ratings

VR = Reverse standoff voltage
BV = Breakdown voltage

IPP = Max. peak pulse current
IT = Test current

Hermetically Sealed Threaded Case Filters



.375 ø T Circuit

Thread length: A - 0.187 (4.76) B - 0.312 (7.92)

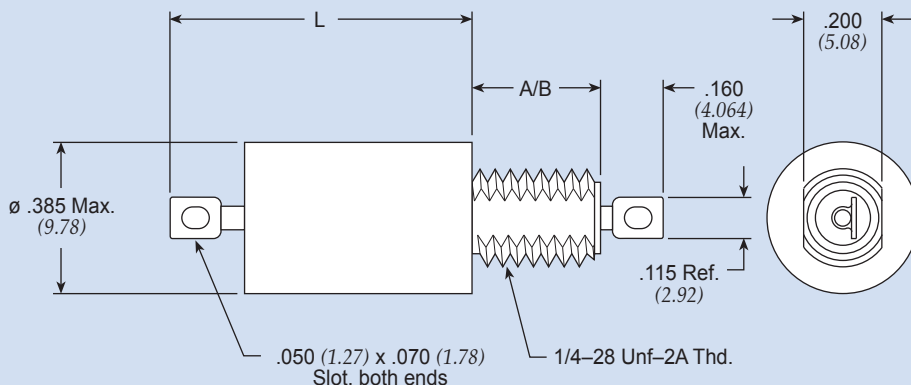

Figure 1

Note: Max. O.D. is ø .416" for Military QPL Filters.

Dimensions in inches (mm)

.375 ø T Circuit Standard Product

| Part Number | MIL No | Figure | Rated Voltage | | | | I Amp | Min Cap µF | DCR Max Ohms | Max L In (mm) | Thd Lgth | Minimum Insertion Loss (dB) | | | | | | |
|-----------------|--------|--------|---------------|----|-------|-----|-------|------------|--------------|----------------|----------|-----------------------------|---------|---------|-------|--------|---------|-------|
| | | | 85°C | | 125°C | | | | | | | 30 KHz | 150 KHz | 300 KHz | 1 MHz | 10 MHz | 100 MHz | 1 GHz |
| | | | DC | AC | DC | AC | | | | | | | | | | | | |
| SCI-2040-012 | — | 1 | 80 | — | 50 | — | 2.00 | 1.400 | 0.126 | 1.071 (27.203) | B | 8 | 22 | 30 | 55 | 70 | 70 | 70 |
| SCI-2040-013 | — | 1 | 80 | — | 50 | — | 3.00 | 1.400 | 0.054 | 1.071 (27.203) | B | 8 | 22 | 28 | 43 | 70 | 70 | 70 |
| † 9004-100-2017 | — | 1 | 80 | — | 50 | — | 15.0 | 1.400 | 0.005 | 1.179 (29.947) | A | 17 | 27 | 34 | 44 | 60 | 70 | 70 |
| SCI-2140-004 | — | 1 | 150 | — | 100 | — | 1.00 | 0.500 | 0.500 | 1.070 (27.178) | A | 4 | 25 | 40 | 70 | 70 | 70 | 70 |
| SCI-2140-006 | — | 1 | 150 | — | 100 | — | 3.00 | 0.500 | 0.054 | 1.071 (27.203) | A | 4 | 19 | 24 | 39 | 70 | 70 | 70 |
| SCI-2140-007 | — | 1 | 150 | — | 100 | — | 10.0 | 0.500 | 0.010 | 1.071 (27.203) | A | 4 | 19 | 24 | 34 | 57 | 70 | 70 |
| SCI-2340-009 | — | 1 | 300 | — | 300 | 125 | 0.25 | 0.150 | 8.000 | 1.071 (27.203) | B | 11 | 57 | 70 | 70 | 70 | 70 | 70 |
| SCI-2340-004 | — | 1 | 300 | — | 300 | 125 | 1.00 | 0.150 | 0.500 | 1.071 (27.203) | A | — | 13 | 29 | 59 | 70 | 70 | 70 |
| SCI-2340-013 | — | 1 | 300 | — | 300 | 125 | 3.00 | 0.150 | 0.054 | 1.071 (27.203) | B | — | 8 | 14 | 29 | 70 | 70 | 70 |
| SCI-2340-014 | — | 1 | 300 | — | 300 | 125 | 10.0 | 0.150 | 0.010 | 1.071 (27.203) | B | — | 8 | 14 | 24 | 47 | 70 | 70 |

† Also available through API's authorized distributors.

(See MIL index on pages CF9-11 for complete MIL part number listing)

.375 ø T Circuit MIL Qualified Product

| Part Number | M15733 MIL No | Figure | Rated Voltage | | | | I Amp | Min Cap µF | DCR Max Ohms | Max L In (mm) | Thd Lgth | Minimum Insertion Loss (dB) | | | | | | |
|--------------|---------------|--------|---------------|----|-------|-----|-------|------------|--------------|----------------|----------|-----------------------------|---------|---------|-------|--------|---------|-------|
| | | | 85°C | | 125°C | | | | | | | 30 KHz | 150 KHz | 300 KHz | 1 MHz | 10 MHz | 100 MHz | 1 GHz |
| | | | DC | AC | DC | AC | | | | | | | | | | | | |
| 51-382-609 | 25-0024 | 1 | — | — | 100 | — | 2.00 | 0.750 | 0.100 | 1.179 (29.947) | B | 10 | 22 | 31 | 55 | 80 | 70 | 70 |
| 51-382-603 | 25-0007 | 1 | — | — | 100 | — | 4.00 | 0.750 | 0.063 | 1.345 (34.163) | A | 10 | 22 | 28 | 43 | 80 | 70 | 70 |
| † 51-351-604 | 26-0012 | 1 | — | — | 150 | 125 | 2.00 | 0.250 | 0.100 | 1.179 (29.947) | A | — | 13 | 21 | 43 | 80 | 70 | 70 |
| 51-351-603 | 26-0008 | 1 | — | — | 150 | 125 | 4.00 | 0.250 | 0.063 | 1.345 (34.163) | A | — | 11 | 18 | 33 | 80 | 70 | 70 |

† Also available through API's authorized distributors.

Hermetically Sealed Threaded Case Filters

.375 ø TT Circuit Standard Product

| Part Number | MIL No | See Pg. LP35 for Fig. | Rated Voltage | | | | I Amp | Min Cap µF | DCR Max Ohms | Max L | | Thd Lgth | Minimum Insertion Loss (dB) | | | | | | |
|--------------|--------|-----------------------|---------------|----|-------|-----|-------|------------|--------------|-------|----------|----------|-----------------------------|---------|---------|-------|--------|---------|-------|
| | | | 85°C | | 125°C | | | | | In | (mm) | | 30 KHz | 150 KHz | 300 KHz | 1 MHz | 10 MHz | 100 MHz | 1 GHz |
| | | | DC | AC | DC | AC | | | | | | | | | | | | | |
| SCI-2060-009 | — | 1 | — | — | 50 | — | 0.25 | 1.500 | 12.000 | 1.241 | (31.521) | B | 70 | 70 | 70 | 70 | 70 | 70 | 70 |
| SCI-2060-013 | — | 1 | — | — | 50 | — | 3.00 | 1.500 | 0.081 | 1.241 | (31.521) | B | — | 33 | 54 | 70 | 70 | 70 | 70 |
| SCI-2060-007 | — | 1 | — | — | 50 | — | 10.0 | 1.500 | 0.006 | 1.241 | (31.521) | A | 15 | 29 | 35 | 42 | 55 | 70 | 70 |
| SCI-2060-014 | — | 1 | — | — | 50 | — | 10.0 | 1.500 | 0.006 | 1.241 | (31.521) | B | 15 | 29 | 35 | 42 | 55 | 70 | 70 |
| SCI-2160-011 | — | 1 | — | — | 100 | — | 1.00 | 1.500 | 0.750 | 1.241 | (31.521) | B | 12 | 52 | 70 | 70 | 70 | 70 | 70 |
| SCI-2160-012 | — | 1 | — | — | 100 | — | 2.00 | 1.500 | 0.189 | 1.241 | (31.521) | B | — | 33 | 56 | 70 | 70 | 70 | 70 |
| SCI-2160-013 | — | 1 | — | — | 100 | — | 3.00 | 1.500 | 0.081 | 1.241 | (31.521) | B | — | 24 | 54 | 70 | 70 | 70 | 70 |
| SCI-2160-014 | — | 1 | — | — | 100 | — | 10.0 | 1.400 | 0.006 | 1.241 | (31.521) | B | 12 | 25 | 32 | 42 | 55 | 70 | 70 |
| SCI-2360-011 | — | 1 | — | — | 300 | 125 | 1.00 | 0.500 | 0.750 | 1.241 | (31.521) | B | — | 48 | 70 | 70 | 70 | 70 | 70 |
| SCI-2360-006 | — | 1 | — | — | 300 | 125 | 3.00 | 0.500 | 0.080 | 1.241 | (31.521) | A | — | 12 | 38 | 70 | 70 | 70 | 70 |
| SCI-2360-007 | — | 1 | — | — | 300 | 125 | 10.0 | 0.500 | 0.006 | 1.241 | (31.521) | A | 5 | 18 | 24 | 34 | 55 | 70 | 70 |
| SCI-2360-014 | — | 1 | — | — | 300 | 125 | 10.0 | 0.500 | 0.006 | 1.241 | (31.521) | B | 5 | 18 | 24 | 34 | 55 | 70 | 70 |

Hermetically Sealed Threaded Case Filters



.690 ø C Circuit

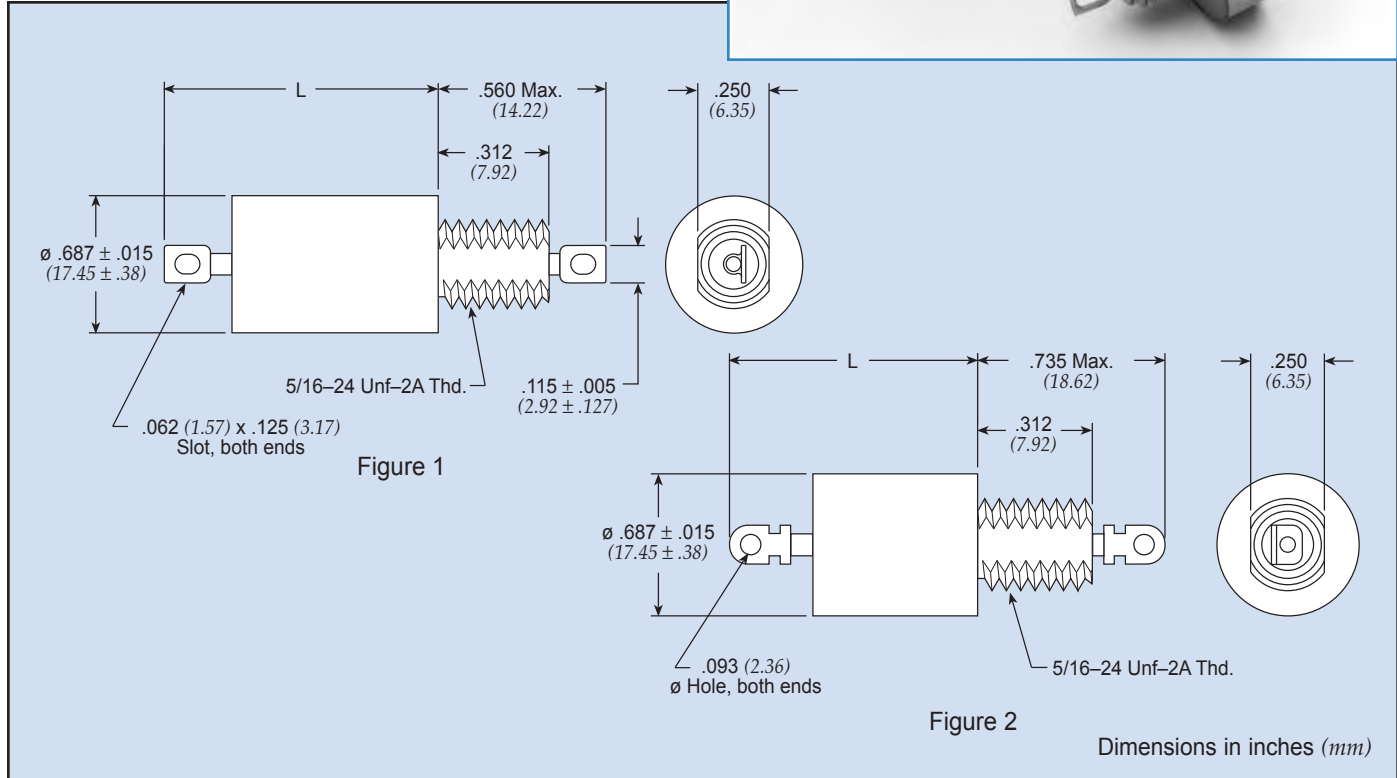

.690 ø C Circuit Standard Product

| Part Number | MIL No | Figure | Rated Voltage | | | | I Amp | Min Cap μ F | DCR Max Ohms | Max L | | Minimum Insertion Loss (dB) | | | | | | |
|-----------------|--------|--------|---------------|-----|-------|-----|-------|-----------------|--------------|-------|----------|-----------------------------|---------|---------|-------|--------|---------|-------|
| | | | 85°C | | 125°C | | | | | In | L (mm) | 30 KHz | 150 KHz | 300 KHz | 1 MHz | 10 MHz | 100 MHz | 1 GHz |
| | | | DC | AC | DC | AC | | | | | | | | | | | | |
| † 9932-100-6004 | — | 1 | 200 | — | 150 | 125 | 15 | 2.600 | 0.005 | 0.702 | (17.831) | 10 | 29 | 39 | 50 | 60 | 70 | 70 |
| 54-310-001 | — | 1 | 300 | — | 300 | 125 | 15 | 0.500 | 0.005 | 0.560 | (14.224) | 6 | 19 | 25 | 36 | 50 | 70 | 70 |
| 54-310-005 | — | 2 | 250 | — | 200 | 125 | 25 | 0.500 | 0.005 | 0.750 | (19.050) | 6 | 19 | 25 | 36 | 50 | 70 | 70 |
| 54-310-009 | — | 1 | 450 | 240 | 400 | 240 | 15 | 0.250 | 0.005 | 0.560 | (14.224) | — | 14 | 19 | 30 | 45 | 60 | 70 |
| † 9932-100-6005 | — | 1 | 450 | 240 | 400 | 240 | 15 | 0.250 | 0.005 | 0.560 | (14.224) | — | 14 | 19 | 30 | 50 | 70 | 70 |

.690 ø C Circuit MIL Qualified Product

| Part Number | M15733 MIL No | Figure | Rated Voltage | | | | I Amp | Min Cap μ F | DCR Max Ohms | Max L | | Minimum Insertion Loss (dB) | | | | | | |
|-------------|---------------|--------|---------------|----|-------|-----|-------|-----------------|--------------|-------|----------|-----------------------------|---------|---------|-------|--------|---------|-------|
| | | | 85°C | | 125°C | | | | | In | L (mm) | 30 KHz | 150 KHz | 300 KHz | 1 MHz | 10 MHz | 100 MHz | 1 GHz |
| | | | DC | AC | DC | AC | | | | | | | | | | | | |
| 54-310-039 | 34-0037 | 1 | — | — | 275 | 125 | 15 | 0.200 | 0.005 | 0.575 | (14.605) | 5 | 15 | 21 | 31 | 51 | 70 | 70 |

.690 ø C Circuit DSCC 84084 Product

| Part Number | 84084 No | Figure | Rated Voltage | | | | I Amp | Min Cap μ F | DCR Max Ohms | Max L | | Minimum Insertion Loss (dB) | | | | | | |
|-------------|----------|--------|---------------|----|-------|-----|-------|-----------------|--------------|-------|----------|-----------------------------|---------|---------|-------|--------|---------|-------|
| | | | 85°C | | 125°C | | | | | In | L (mm) | 30 KHz | 150 KHz | 300 KHz | 1 MHz | 10 MHz | 100 MHz | 1 GHz |
| | | | DC | AC | DC | AC | | | | | | | | | | | | |
| 54-310-042 | -001 | 1 | — | — | 400 | 230 | 15 | 0.150 | 0.005 | 0.700 | (17.780) | — | 10 | 16 | 26 | 40 | 52 | 70 |

† Also available through API's authorized distributors.

Hermetically Sealed Threaded Case Filters



.690 ø L Circuit

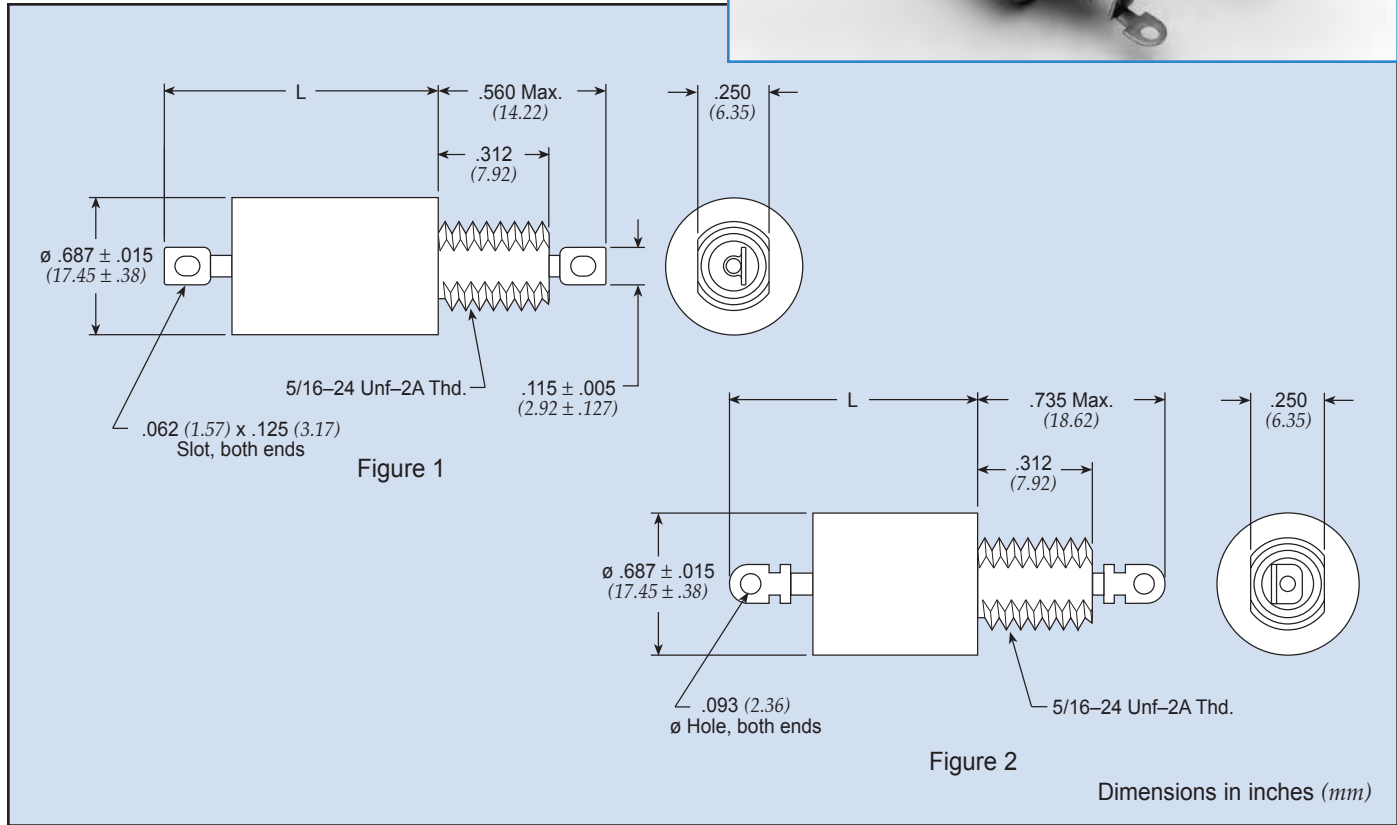

.690 ø L Circuit Standard Product

| Part Number | MIL No | Figure | Rated Voltage | | | | I Amp | Min Cap µF | DCR Max Ohms | CKT | Max L | | Minimum Insertion Loss (dB) | | | | | | |
|---------------|--------|--------|---------------|-----|-------|-----|-------|------------|--------------|-----|-------|----------|-----------------------------|---------|---------|-------|--------|---------|-------|
| | | | 85°C | | 125°C | | | | | | In | L (mm) | 30 KHz | 150 KHz | 300 KHz | 1 MHz | 10 MHz | 100 MHz | 1 GHz |
| 9010-100-0049 | — | 1 | 150 | — | 100 | — | 10.0 | 1.400 | 0.005 | LT | 0.905 | (22.987) | 16 | 24 | 34 | 44 | 60 | 70 | 70 |
| SCI-6120-008 | — | 1 | 150 | — | 100 | — | 10.0 | 2.600 | 0.006 | LB | 0.959 | (24.359) | 18 | 32 | 39 | 49 | 70 | 70 | 70 |
| SCI-6120-009 | — | 1 | 150 | — | 100 | — | 20.0 | 2.600 | 0.001 | LB | 0.905 | (22.987) | 18 | 32 | 39 | 49 | 60 | 70 | 70 |
| 51-320-041 | — | 1 | 250 | — | 200 | 125 | 10.0 | 0.500 | 0.008 | LT | 0.905 | (22.987) | 5 | 19 | 25 | 35 | 50 | 70 | 70 |
| 51-320-024 | — | 1 | 450 | 240 | 400 | 240 | 1.00 | 0.360 | 0.210 | LT | 0.905 | (22.987) | 5 | 30 | 38 | 60 | 70 | 70 | 70 |
| 51-320-100 | — | 1 | 450 | 240 | 400 | 240 | 1.00 | 0.250 | 0.210 | LT | 0.905 | (22.987) | — | 21 | 33 | 55 | 70 | 70 | 70 |
| † 51-320-026 | — | 1 | 450 | 240 | 400 | 240 | 3.00 | 0.360 | 0.030 | LT | 0.905 | (22.987) | 5 | 19 | 25 | 45 | 70 | 70 | 70 |
| 51-320-103 | — | 1 | 450 | 240 | 400 | 240 | 5.00 | 0.360 | 0.010 | LB | 0.905 | (22.987) | — | 12 | 18 | 30 | 60 | 70 | 70 |
| 51-322-007 | — | 1 | 450 | 240 | 400 | 240 | 15.0 | 0.360 | 0.007 | LB | 0.650 | (16.510) | 5 | 19 | 25 | 35 | 48 | 62 | 70 |
| 51-322-015 | — | 2 | 450 | 240 | 400 | 240 | 25.0 | 0.360 | 0.007 | LT | 0.750 | (19.050) | 5 | 17 | 23 | 34 | 48 | 62 | 70 |
| 51-322-036 | — | 2 | 450 | 240 | 400 | 240 | 25.0 | 0.250 | 0.007 | LB | 0.750 | (19.050) | — | 10 | 16 | 29 | 45 | 60 | 70 |
| 9010-100-0054 | — | 1 | 450 | 240 | 300 | 240 | 1.00 | 0.150 | 0.250 | LT | 0.905 | (22.987) | — | 14 | 32 | 52 | 70 | 70 | 70 |
| SCI-6320-004 | — | 1 | 300 | — | 300 | 125 | 1.00 | 0.400 | 0.300 | LB | 0.959 | (24.359) | 6 | 24 | 35 | 56 | 70 | 70 | 70 |

† Also available through API's authorized distributors.

Hermetically Sealed Threaded Case Filters

L-C Filter LT

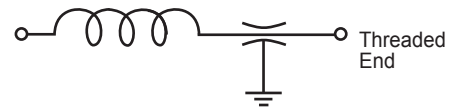

L-C Filter LB

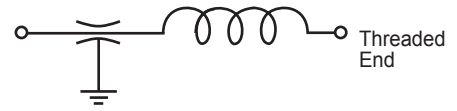

(See MIL index on pages CF9-11 for complete MIL part number listing)

.690 ø L Circuit MIL Qualified Product

| Part Number | M15733 MIL No | See Pg. LP38 for Fig. | Rated Voltage | | | | I Amp | Min Cap μ F | DCR Max Ohms | CKT | Max L In | Max L (mm) | Minimum Insertion Loss (dB) | | | | | | | |
|--------------|---------------|-----------------------|---------------|----|-------|-----|-------|-----------------|--------------|-----|----------|------------|-----------------------------|---------|---------|-------|--------|---------|-------|--|
| | | | 85°C | | 125°C | | | | | | | | 30 KHz | 150 KHz | 300 KHz | 1 MHz | 10 MHz | 100 MHz | 1 GHz | |
| | | | DC | AC | DC | AC | | | | | | | | | | | | | | |
| † 51-320-015 | 27-0005 | 1 | — | — | 200 | 125 | 3.00 | 0.250 | 0.033 | LT | 0.900 | (22.860) | — | 14 | 21 | 39 | 80 | 70 | 70 | |
| 51-320-017 | 27-0008 | 1 | — | — | 200 | 125 | 5.00 | 0.250 | 0.016 | LT | 0.900 | (22.860) | — | 13 | 19 | 32 | 69 | 70 | 70 | |
| 51-320-018 | 27-0009 | 1 | — | — | 200 | 125 | 5.00 | 0.250 | 0.016 | LB | 0.900 | (22.860) | — | 13 | 19 | 32 | 69 | 70 | 70 | |
| 51-323-003 | 27-0011 | 1 | — | — | 200 | 125 | 10.0 | 0.250 | 0.005 | LT | 1.031 | (26.187) | — | 13 | 19 | 30 | 61 | 70 | 70 | |
| 51-323-004 | 27-0012 | 1 | — | — | 200 | 125 | 10.0 | 0.250 | 0.005 | LB | 1.031 | (26.187) | — | 13 | 19 | 30 | 61 | 70 | 70 | |
| † 51-322-009 | 27-0014 | 2 | — | — | 200 | 125 | 15.0 | 0.250 | 0.007 | LT | 1.763 | (44.780) | — | 19 | 25 | 36 | 60 | 70 | 70 | |
| 51-322-017 | 34-0002 | 2 | — | — | 200 | 125 | 20.0 | 0.360 | 0.050 | LB | 1.763 | (44.780) | — | 19 | 25 | 35 | 57 | 70 | 70 | |

.690 ø L Circuit DSCC 84084 Product

| Part Number | 84084 No | See Pg. LP38 for Fig. | Rated Voltage | | | | I Amp | Min Cap μ F | DCR Max Ohms | CKT | Max L In | Max L (mm) | Minimum Insertion Loss (dB) | | | | | | | |
|-------------|----------|-----------------------|---------------|----|-------|-----|-------|-----------------|--------------|-----|----------|------------|-----------------------------|---------|---------|-------|--------|---------|-------|--|
| | | | 85°C | | 125°C | | | | | | | | 30 KHz | 150 KHz | 300 KHz | 1 MHz | 10 MHz | 100 MHz | 1 GHz | |
| | | | DC | AC | DC | AC | | | | | | | | | | | | | | |
| 51-320-162 | -004 | 1 | — | — | 400 | 230 | 1.00 | 0.150 | 0.150 | LT | 0.905 | (22.987) | — | 19 | 30 | 46 | 60 | 70 | 70 | |
| 51-320-163 | -005 | 1 | — | — | 400 | 230 | 1.00 | 0.150 | 0.150 | LB | 0.905 | (22.987) | — | 19 | 30 | 46 | 60 | 70 | 70 | |
| 51-320-164 | -006 | 1 | — | — | 400 | 230 | 3.00 | 0.150 | 0.026 | LT | 0.905 | (22.987) | — | 11 | 19 | 36 | 60 | 70 | 70 | |
| 51-320-165 | -007 | 1 | — | — | 400 | 230 | 3.00 | 0.150 | 0.026 | LB | 0.905 | (22.987) | — | 11 | 19 | 36 | 60 | 70 | 70 | |
| 51-320-166 | -008 | 1 | — | — | 400 | 230 | 5.00 | 0.150 | 0.013 | LT | 0.905 | (22.987) | — | 10 | 16 | 28 | 54 | 70 | 70 | |
| 51-320-167 | -009 | 1 | — | — | 400 | 230 | 5.00 | 0.150 | 0.013 | LB | 0.905 | (22.987) | — | 10 | 16 | 28 | 54 | 70 | 70 | |
| 51-320-168 | -010 | 1 | — | — | 400 | 230 | 10.0 | 0.150 | 0.008 | LT | 0.905 | (22.987) | — | 10 | 16 | 25 | 48 | 70 | 70 | |
| 51-320-169 | -011 | 1 | — | — | 400 | 230 | 10.0 | 0.150 | 0.008 | LB | 0.905 | (22.987) | — | 10 | 16 | 25 | 48 | 70 | 70 | |

† Also available through API's authorized distributors.

Hermetically Sealed Threaded Case Filters

.690 ø Pi Circuit

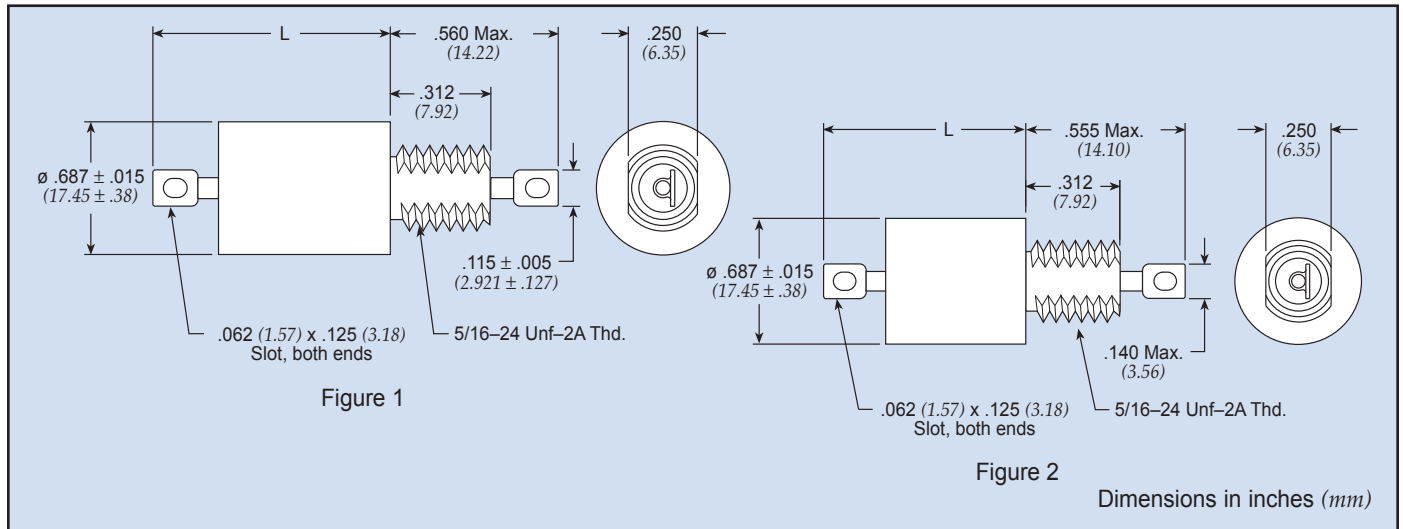

.690 ø Pi Circuit Standard Product

| Part Number | MIL No | Figure | Rated Voltage | | | | I Amp | Min Cap μ F | DCR Max Ohms | Max L (mm) | | Minimum Insertion Loss (dB) | | | | | | |
|--------------|--------|--------|---------------|-----|-------|------|-------|-----------------|--------------|------------|----------|-----------------------------|---------|---------|-------|--------|---------|-------|
| | | | 85°C | | 125°C | | | | | | | 30 KHz | 150 KHz | 300 KHz | 1 MHz | 10 MHz | 100 MHz | 1 GHz |
| | | | DC | AC | DC | AC | | | | | | In | L | | | | | |
| 51-321-322 | — | 1 | 150 | — | 100 | — | 1.00 | 2.800 | 0.210 | 1.195 | (30.353) | 35 | 69 | 70 | 70 | 70 | 70 | 70 |
| SCI-6130-009 | — | 1 | 150 | — | 100 | — | 20.0 | 5.200 | 0.001 | 1.195 | (30.353) | 23 | 31 | 35 | 35 | 70 | 70 | 70 |
| 51-321-317 | — | 1 | 450 | 240 | 400 | *240 | 1.00 | 0.720 | 0.400 | 1.195 | (30.353) | — | 53 | 70 | 70 | 70 | 70 | 70 |
| †51-321-318 | — | 1 | 450 | 240 | 400 | *240 | 3.00 | 0.720 | 0.030 | 1.195 | (30.353) | — | 31 | 51 | 70 | 70 | 70 | 70 |
| †51-321-319 | — | 1 | 450 | 240 | 400 | *240 | 5.00 | 0.720 | 0.020 | 1.195 | (30.353) | — | 11 | 30 | 65 | 70 | 70 | 70 |

* 0-60 Hz

.690 ø Pi Circuit MIL Qualified Product

(See MIL index on pages CF8-10 for complete MIL part number listing)

| Part Number | M15733 MIL No | Figure | Rated Voltage | | | | I Amp | Min Cap μ F | DCR Max Ohms | Max L (mm) | | Minimum Insertion Loss (dB) | | | | | | |
|-------------|---------------|--------|---------------|----|-------|-----|-------|-----------------|--------------|------------|----------|-----------------------------|---------|---------|-------|--------|---------|-------|
| | | | 85°C | | 125°C | | | | | | | 30 KHz | 150 KHz | 300 KHz | 1 MHz | 10 MHz | 100 MHz | 1 GHz |
| | | | DC | AC | DC | AC | | | | | | In | L | | | | | |
| 51-321-312 | 27-0004 | 1 | — | — | 200 | 125 | 1.00 | 0.500 | 0.250 | 1.195 | (30.353) | — | 47 | 65 | 80 | 80 | 70 | 70 |
| 51-323-313 | 27-0003 | 1 | — | — | 200 | 125 | 1.00 | 0.500 | 0.270 | 1.031 | (26.187) | — | 43 | 61 | 80 | 80 | 70 | 70 |
| 51-321-313 | 27-0010 | 1 | — | — | 200 | 125 | 5.00 | 0.500 | 0.024 | 1.195 | (30.353) | — | 10 | 28 | 64 | 80 | 70 | 70 |
| †51-321-314 | 27-0013 | 1 | — | — | 200 | 125 | 10.0 | 0.500 | 0.008 | 1.195 | (30.353) | — | 16 | 18 | 48 | 80 | 70 | 70 |
| 51-321-329 | 34-0005 | 1 | — | — | 200 | 125 | 10.0 | 0.500 | 0.075 | 1.195 | (30.353) | — | 16 | 18 | 48 | 80 | 70 | 70 |

.690 ø Pi Circuit DSCC 84084 Product

| Part Number | 84084 No | Figure | Rated Voltage | | | | I Amp | Min Cap μ F | DCR Max Ohms | Max L (mm) | | Minimum Insertion Loss (dB) | | | | | | |
|-------------|----------|--------|---------------|----|-------|-----|-------|-----------------|--------------|------------|----------|-----------------------------|---------|---------|-------|--------|---------|-------|
| | | | 85°C | | 125°C | | | | | | | 30 KHz | 150 KHz | 300 KHz | 1 MHz | 10 MHz | 100 MHz | 1 GHz |
| | | | DC | AC | DC | AC | | | | | | In | L | | | | | |
| 51-321-398 | -013 | 2 | — | — | 400 | 230 | 1.00 | 0.200 | 0.150 | 1.200 | (30.480) | — | 27 | 46 | 74 | 80 | 80 | 80 |
| 51-321-399 | -014 | 2 | — | — | 400 | 230 | 3.00 | 0.200 | 0.026 | 1.200 | (30.480) | — | — | 30 | 60 | 80 | 80 | 80 |
| 51-321-400 | -015 | 2 | — | — | 400 | 230 | 5.00 | 0.200 | 0.013 | 1.200 | (30.480) | — | — | 12 | 50 | 80 | 80 | 80 |
| 51-321-401 | -016 | 2 | — | — | 400 | 230 | 10.0 | 0.200 | 0.008 | 1.200 | (30.480) | — | — | — | 30 | 80 | 80 | 80 |

† Also available through API's authorized distributors.

Hermetically Sealed Threaded Case Filters

.690 ø T Circuit

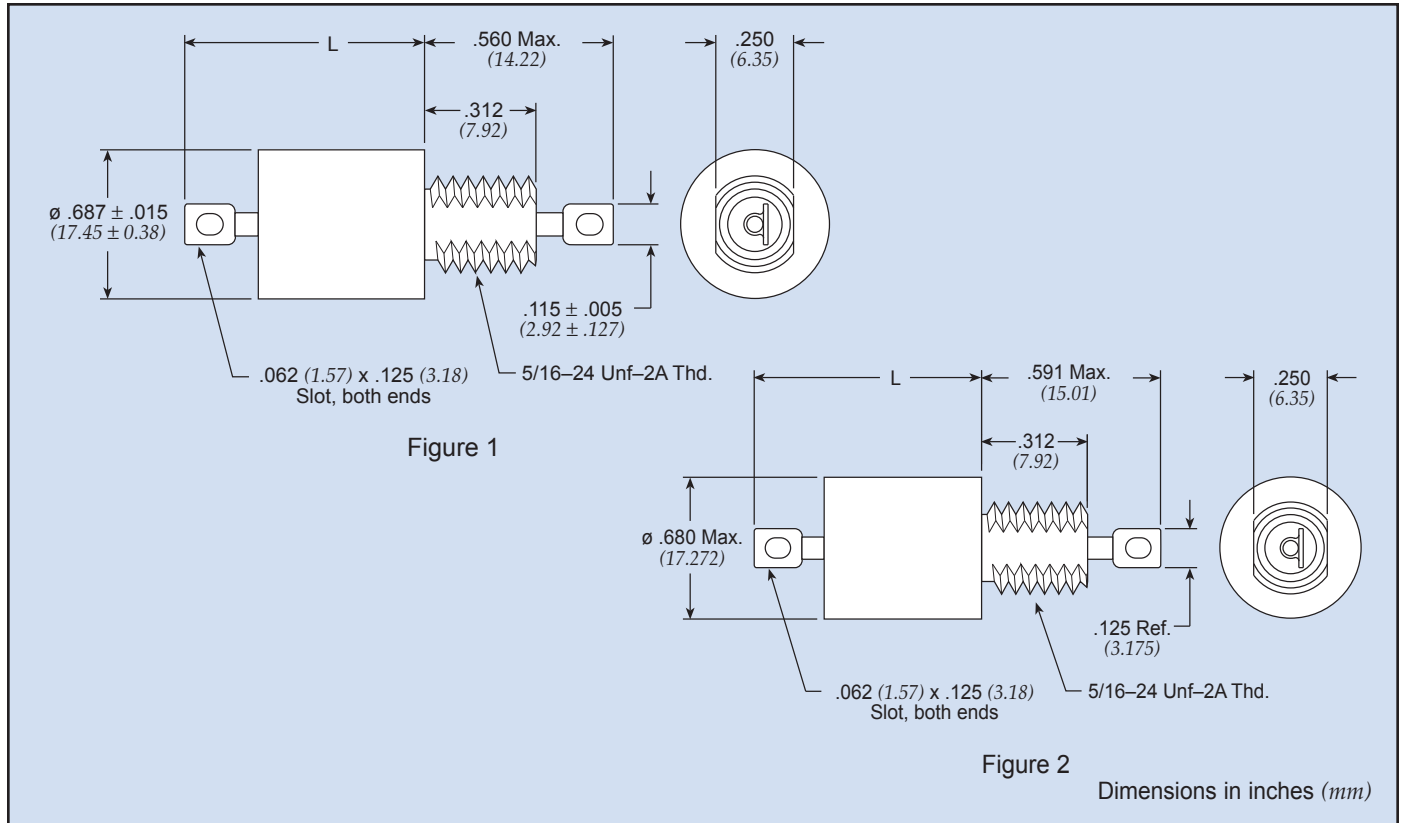

.690 ø T Circuit Standard Product

| Part Number | MIL No | Figure | Rated Voltage | | | | I Amp | Min Cap μ F | DCR Max Ohms | Max L (mm) | | Minimum Insertion Loss (dB) | | | | | | |
|--------------|--------|--------|---------------|-----|-------|-----|-------|-----------------|--------------|------------|----------|-----------------------------|---------|---------|-------|--------|---------|-------|
| | | | 85°C | | 125°C | | | | | | | 30 KHz | 150 KHz | 300 KHz | 1 MHz | 10 MHz | 100 MHz | 1 GHz |
| | | | DC | AC | DC | AC | | | | | | In | | | | | | |
| SCI-6140-004 | — | 1 | 150 | — | 100 | — | 1.00 | 2.600 | 0.600 | 1.195 | (30.353) | 23 | 54 | 70 | 70 | 70 | 70 | 70 |
| SCI-6140-006 | — | 1 | 150 | — | 100 | — | 3.00 | 2.600 | 0.100 | 1.195 | (30.353) | 21 | 35 | 46 | 70 | 70 | 70 | 70 |
| SCI-6140-007 | — | 1 | 150 | — | 100 | — | 5.00 | 2.600 | 0.060 | 1.195 | (30.353) | 21 | 34 | 41 | 58 | 70 | 70 | 70 |
| SCI-6140-009 | — | 1 | 150 | — | 100 | — | 20.0 | 2.600 | 0.002 | 1.195 | (30.353) | 21 | 35 | 41 | 50 | 60 | 70 | 70 |
| 51-321-649 | — | 1 | 250 | 125 | 200 | 125 | 2.00 | 0.360 | 0.090 | 1.195 | (30.353) | — | 24 | 38 | 65 | 70 | 70 | 70 |
| † 51-321-610 | — | 1 | 450 | 240 | 400 | 240 | 1.00 | 0.360 | 0.600 | 1.195 | (30.353) | 7 | 43 | 60 | 70 | 70 | 70 | 70 |

.690 ø T Circuit MIL Qualified Product

(See MIL index on pages CF8-10 for complete MIL part number listing)

| Part Number | M15733 MIL No | Figure | Rated Voltage | | | | I Amp | Min Cap μ F | DCR Max Ohms | Max L (mm) | | Minimum Insertion Loss (dB) | | | | | | |
|-------------|---------------|--------|---------------|----|-------|-----|-------|-----------------|--------------|------------|----------|-----------------------------|---------|---------|-------|--------|---------|-------|
| | | | 85°C | | 125°C | | | | | | | 30 KHz | 150 KHz | 300 KHz | 1 MHz | 10 MHz | 100 MHz | 1 GHz |
| | | | DC | AC | DC | AC | | | | | | In | | | | | | |
| 51-321-607 | 27-0017 | 1 | — | — | 200 | 125 | 1.50 | 0.250 | 0.133 | 1.195 | (30.353) | — | 19 | 32 | 62 | 70 | 70 | 70 |
| 51-321-608 | 27-0018 | 1 | — | — | 200 | 125 | 4.00 | 0.250 | 0.025 | 1.195 | (30.353) | — | 14 | 21 | 36 | 70 | 70 | 70 |
| 51-321-670 | 54-0017 | 2 | — | — | 300 | 115 | 10.0 | 0.500 | 0.006 | 1.177 | (29.896) | 5 | 20 | 23 | 35 | 60 | 70 | 60 |

† Also available through API's authorized distributors.

Value-Added Low Pass Filter Assemblies

API Technologies' Spectrum Control line of value-added low pass filters provide flexible solutions to meet your unique design challenges. Our manufacturing process allows you to add connectors, modify terminations or add wire harnesses without adding much cost or drastically increasing lead times.

For custom requirements and exceptional needs, contact our design/manufacturing team.

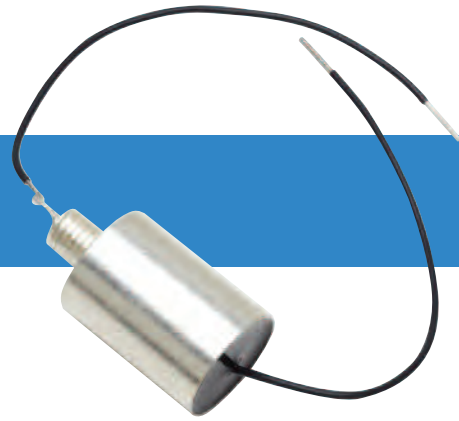

Incorporate specific terminations, connectors or wire harnesses to accommodate your application.

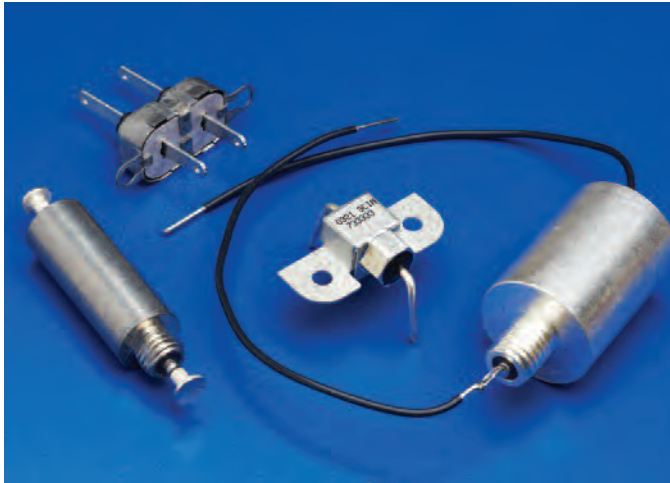

Lower the cost of acquisition and assembly.



Reduce production operations and lead times.

Our value-added services:

- Allow you to stream-line your bill of materials.
- Reduce inventory/production costs.
- Offer custom application-specific low pass filter assemblies.



Build-to-order low pass filters.

EMI Filtered Arrays

our filter plates and terminal blocks provide exceptional EMI protection of signal and power lines at a lower total installed cost



Easy Mate® Filter Plates reduce installation time and overall cost with its patented snap-in design to maximize real estate on PCBs. The Easy Mate® Jr. offers a lower profile for installation of feed-through filters into small hardware applications... **FA3-FA8**

Bolt-In Filter Plates provide EMI filtering for signal and power lines and an excellent method for electronic system interface. These plates eliminate the need to mount filters into bulkheads and are ideal for the isolation of electronic compartments to suppress EMI... **FA9-FA12**

Shrouded Latch Filter Plates combine a bolt-in filter plate with the latching feature of a ribbon cable header providing an easy to install and highly effective method for an electronic interface and EMI solution in one package... **FA13-FA14**

Barrier Strip Filtered Terminal Blocks are available in 2 to 6 terminal versions and our filter elements provide high insertion loss for EMI/RFI filtering of AC and DC power and control lines... **FA19-FA20**

PCB Mount Filtered Terminal Blocks with 2 to 12 terminals available, they provide quick and easy PCB installation and maintenance with a filter element that delivers high insertion loss for EMI/RFI filtering of low voltage DC power and control lines... **FA22-FA23**

Custom Filtered Arrays help meet your design or manufacturing parameters through special mechanical and electrical specifications or by adding varying cable lengths and terminations for a complete turnkey assembly. Custom high reliability assemblies available... **FA24**



Advantages of a Filtered Array

- Provide an EMI filtered signal or power line between electronic system modules
- Reduce cost . . . economical method to meet EMC requirements
- Reduce labor . . . eliminate need to assemble filters into a bulkhead
- Outperform surface mount EMI filters at frequencies above 50 MHz
- Reduce risk of damage to filter elements due to thermal shock and installation
- Improve reliability . . . every filter plate is 100% tested for key parameters
- Maximize real estate on PCB
- Mixed schematics in a single filter plate package

Filter Plates

Eliminating EMI/RFI interference has become a stringently enforced matter and needs to be considered at the early stages of design for all electronic systems. Both internal and external interference sources have a major impact on the successful EMC performance of a new system.

Shielding alone is unsatisfactory in shunting unwanted harmonics, conducted or radiated, on power/control lines that run through compartments of an electronic enclosure. This is particularly applicable in systems operating at frequencies above 50 MHz. Isolation and the incorporation of feed-through filters (Filter Plates) to facilitate entering or leaving sensitive compartments in an assembly are excellent methods to bring electronic interdependent functions/systems into compliance.

Filter plates allow a means of interfacing voltage and/or data (controlling instructions) to distant areas of a system without compromising its performance. Filter plates provide excellent isolation from 5 MHz to 18 GHz and beyond, reduce the labor involved for installation, and reduce the risk of damaging filter elements during installation. Connecting to these filter plates is easily accomplished through several methods, including ribbon style connectors, harnesses, hard wiring or directly soldering leads at a 90° angle to the printed circuit board.

The drawings on pages FA4, FA10 and FA14 illustrate how filter plates are incorporated into an electronic system.

Filter Plate Advantages

- Provide an EMI filtered signal line between electronic system modules
- Reduce cost . . . economical method to meet EMC requirements
- Reduce labor . . . eliminate need to assemble filters into a bulkhead
- Outperform surface mount EMI filters at frequencies above 50 MHz
- Reduce risk of damage to filter elements due to thermal shock and installation
- Improve reliability . . . every filter plate is 100% tested for key parameters
- Maximize real estate on PCB
- Mixed schematics in a single filter plate package

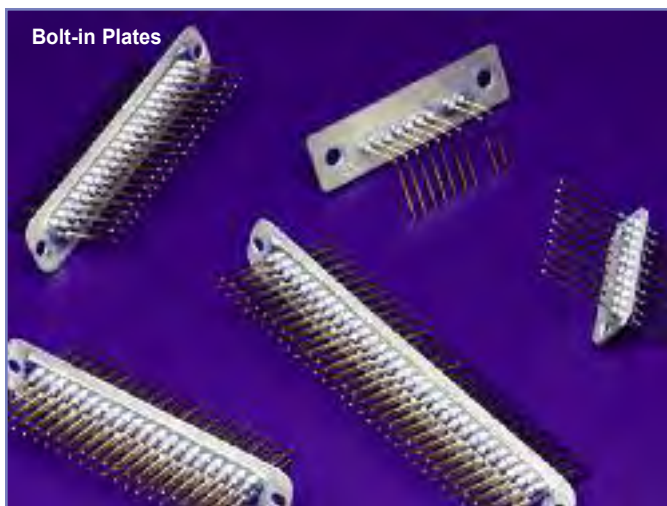
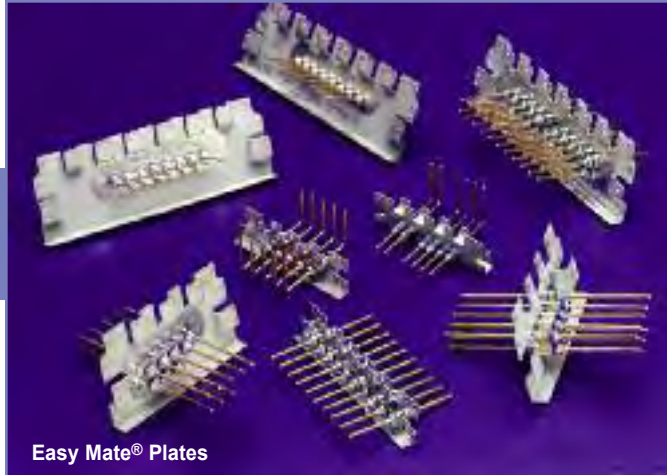

Easy Mate® Filter Plates

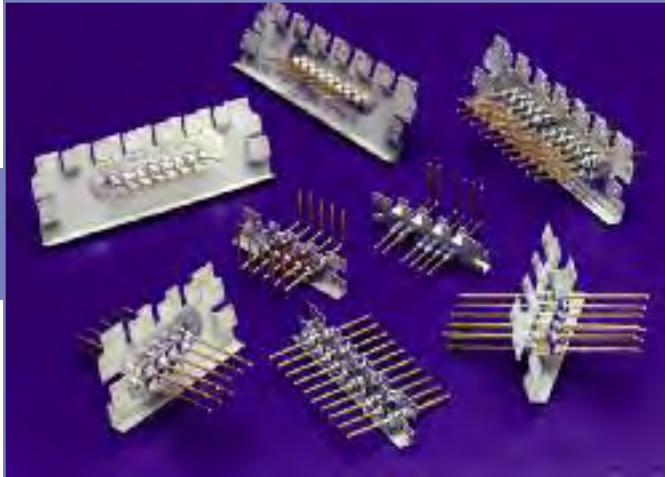

API's Spectrum Control brand developed an EMI/RFI filter plate, Easy Mate®, which simplifies installation and eliminates the need for mounting hardware. The Easy Mate®, **patented**, is designed to "snap" into the chassis of electronic systems, reducing the labor required to complete a plate installation. The drawing on page FA4 shows the Easy Mate® design.

These plates are available in two lengths and in both standard density centers (.100") and high-density centers (2mm). Standard density Easy Mate® plates offer up to 26 lines per plate in a double row configuration, while high-density plates offer up to 32 lines. Custom sizes for Easy Mate® plates are available.

Easy Mate® Advantages

- Reduces installation time and overall cost
- Eliminates mounting hardware and prepwork
- Flexibility for 1 or 2 rows and standard density centers (.100") or high density centers (2mm)
- Improves overall quality and reliability
- Multiple dimpled finger ground contacts provides excellent long term EMI filtering from 5 MHz to 18 GHz
- Outperforms surface mount devices
- Maximize real estate on PCB
- Mixed capacitance values and schematics
- Ideal for isolation of electronic compartments
- Available in RoHS compliant versions

Ordering Information

Example: 52-898-206-B A 2

The part number shown represents an Easy Mate® filter plate with 2 rows, 6 filters per row. Filters are C style with a capacitance value of 100pF. The plate length is 1.092", and the leads are bent 90° to the right side.

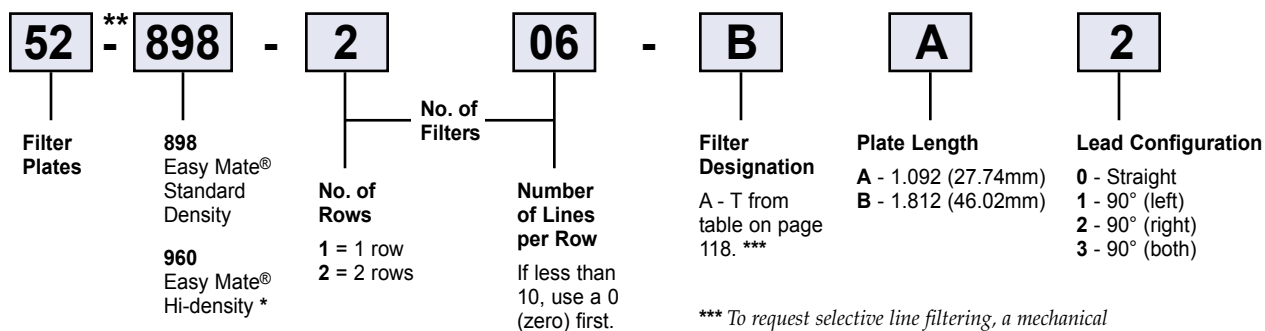

* Maximum capacitance up to 4000pF C style filter

** Replace "-" with "F" for RoHS complaint version

*** To request selective line filtering, a mechanical configuration or material specification not shown in this catalog, please complete and forward the design inquiry form on page FA18. We will review your request and provide you with a part number.

Easy Mate® Filter Plates

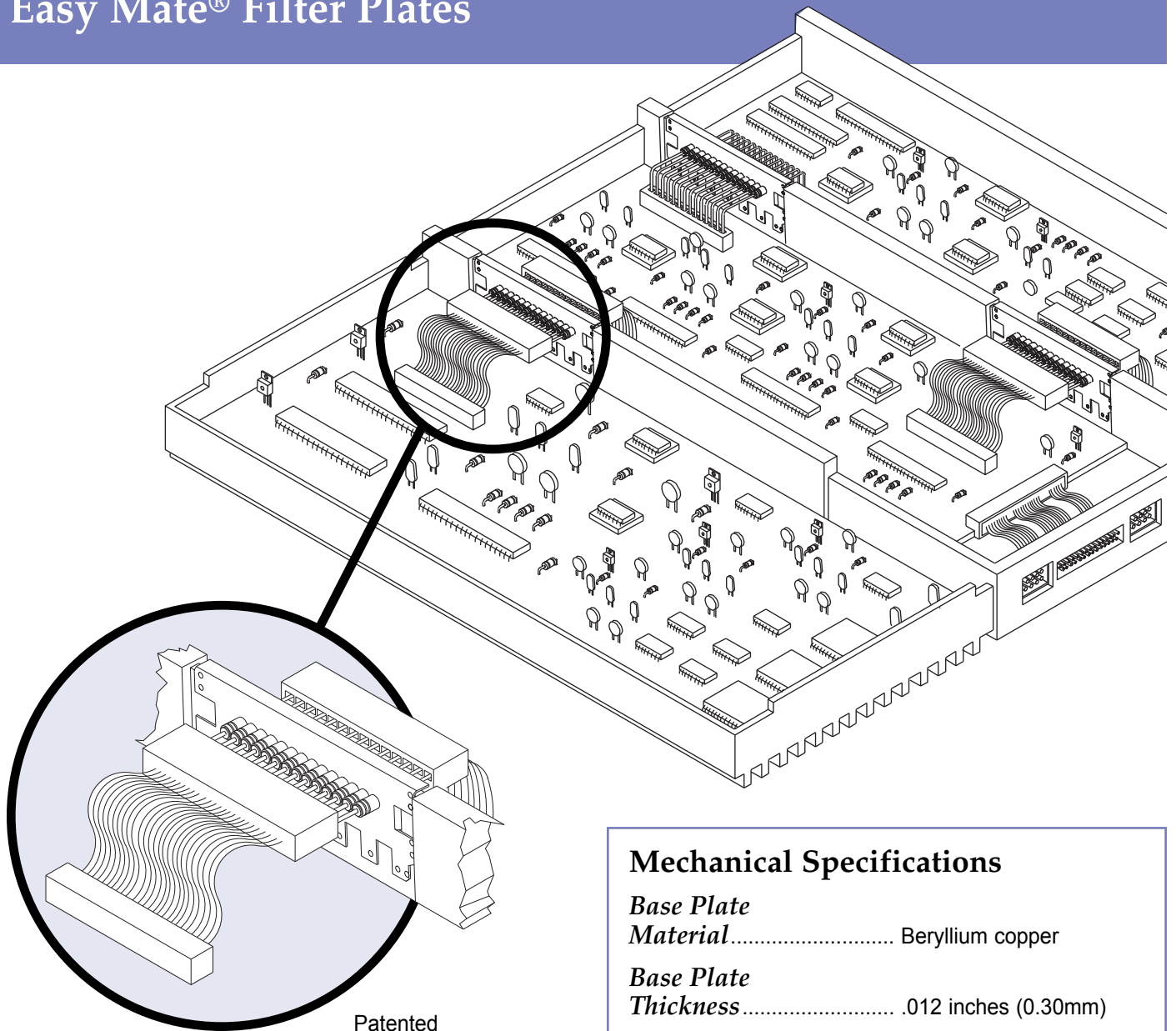

Soldering to Filter Terminals

- Use a temperature controlled soldering iron with tip temperature of 525 ± 10° F (275 ± 5° C).
- Use an SN 63 RMA flux core solder.
- Make mechanical wire connection.
- Use heat sink next to filter body where possible.
- Clean soldering iron tip.
- Clip end of solder—remove 0.5" (12.7mm) to expose flux for soldering.
- Apply soldering iron to wire/flag junction at wetted solder tip region of iron (Wetted Bridge Method). Immediately apply solder. Dwell time for soldering iron tip on product should be 3-5 seconds maximum. (For non-RoHS versions only)

Mechanical Specifications

| | |
|-----------------------------|--|
| Base Plate | |
| Material | Beryllium copper |
| Base Plate | |
| Thickness | .012 inches (0.30mm) |
| Plating | Tin, RoHS version will be silver |
| Lead Material | Copper alloy |
| Lead Plating | Gold plate |
| Lead Diameter | ø .025" (.64mm) for 0.100" centers (2.54mm) |
| | ø .020 (.51mm) for 0.079" centers (2.00mm) |
| Current Rating | 5 Amps for .025" ø (.64mm) |
| | 3 Amps for .020" ø (.51mm) |

Easy Mate® Filter Plates

Standard Density Centers .100"

Dimensions: inches and (mm)
Lead Spacing: .100" (2.54 mm)

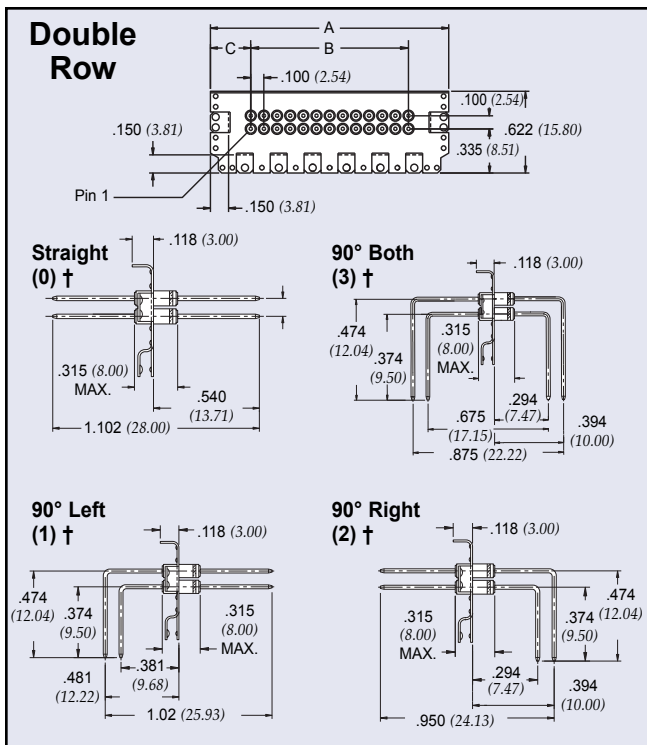
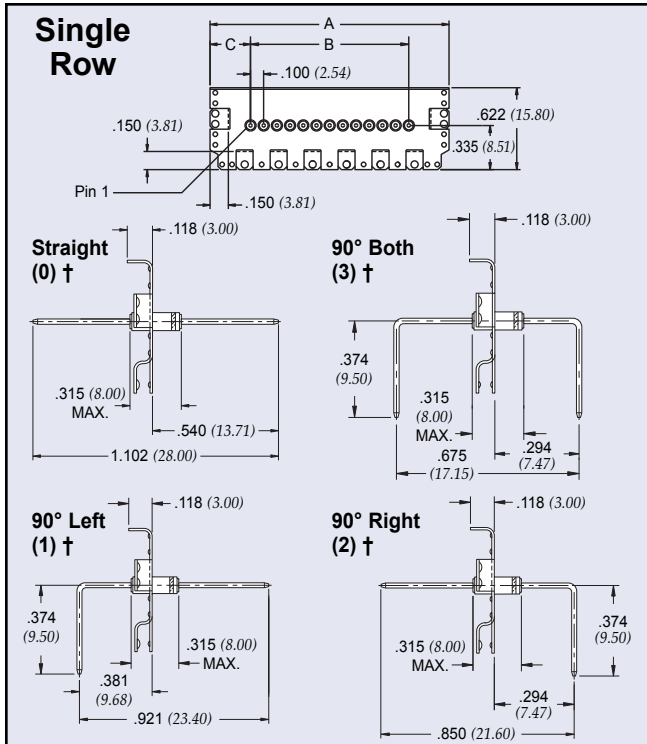

Patented
† Refers to lead configuration for part number/ordering information

| Plate length (A) | No. of filtered lines per row | 52-898-XXX-XXX | |
|------------------|-------------------------------|----------------|---------------|
| | | B | C |
| 1.092 (27.74) | 1 | 0 (0.00) | 0.496 (12.60) |
| | 2 | 0.1 (2.54) | 0.496 (12.60) |
| | 3 | 0.2 (5.08) | 0.396 (10.06) |
| | 4 | 0.3 (7.62) | 0.396 (10.06) |
| | 5 | 0.4 (10.16) | 0.296 (7.52) |
| | 6 | 0.5 (12.70) | 0.296 (7.52) |
| 1.812 (46.02) | 1 | 0 (0.00) | 0.906 (23.01) |
| | 2 | 0.1 (2.54) | 0.806 (20.47) |
| | 3 | 0.2 (5.08) | 0.806 (20.47) |
| | 4 | 0.3 (7.62) | 0.706 (17.93) |
| | 5 | 0.4 (10.16) | 0.706 (17.93) |
| | 6 | 0.5 (12.70) | 0.606 (15.39) |
| | 7 | 0.6 (15.24) | 0.606 (15.39) |
| | 8 | 0.7 (17.78) | 0.506 (12.85) |
| | 9 | 0.8 (20.32) | 0.506 (12.85) |
| | 10 | 0.9 (22.86) | 0.406 (10.31) |
| | 11 | 1.0 (25.40) | 0.406 (10.31) |
| | 12 | 1.1 (27.94) | 0.306 (7.77) |
| | 13 | 1.2 (30.48) | 0.306 (7.77) |

Typical Mounting Applications

Standard Density .100" Centers

Board mounted to .312 standoffs

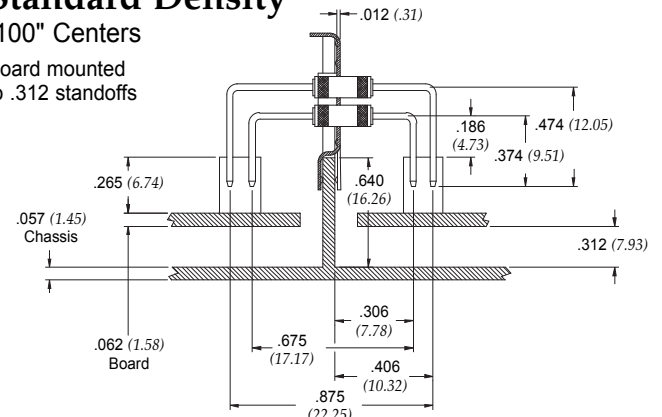

High-Density 2mm Centers

Board mounted to .312 standoffs

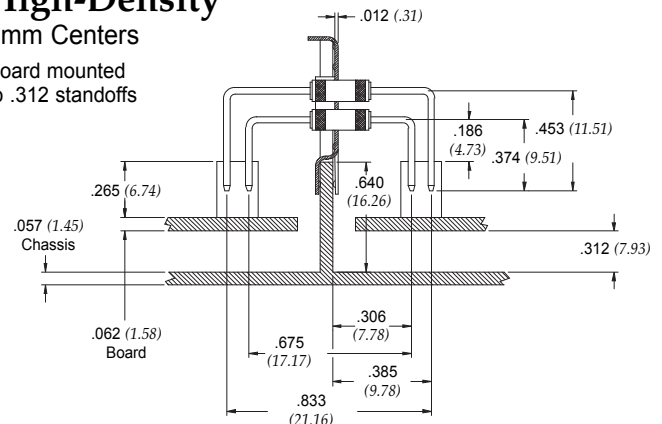

Easy Mate® Filter Plates

Hi-Density Centers 2mm

Dimensions: inches and (mm)
Lead Spacing: .079" (2.00 mm)

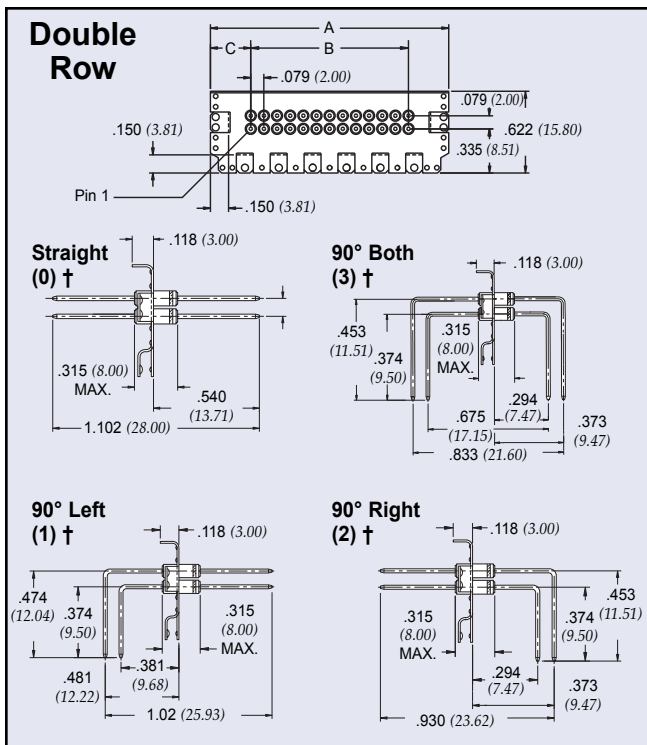
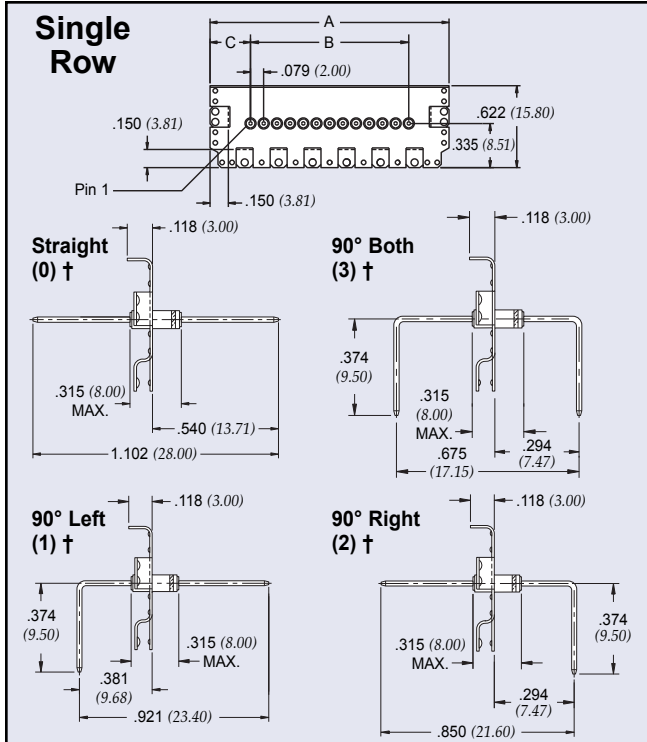

| Plate length (A) | No. of filtered lines per row | 52-960-XXX-XXX | |
|------------------|-------------------------------|----------------|---------------|
| | | B | C |
| 1.092 (27.74) | 2 | 0.079 (2.00) | 0.463 (11.77) |
| | 3 | 0.157 (4.00) | 0.463 (11.77) |
| | 4 | 0.236 (6.00) | 0.385 (9.77) |
| | 5 | 0.315 (8.00) | 0.385 (9.77) |
| | 6 | 0.394 (10.00) | 0.306 (7.77) |
| 1.812 (46.02) | 7 | 0.472 (12.00) | 0.306 (7.77) |
| | 2 | 0.079 (2.00) | 0.866 (22.00) |
| | 3 | 0.157 (4.00) | 0.787 (20.00) |
| | 4 | 0.236 (6.00) | 0.787 (20.00) |
| | 5 | 0.315 (8.00) | 0.709 (18.00) |
| | 6 | 0.394 (10.00) | 0.709 (18.00) |
| | 7 | 0.472 (12.00) | 0.630 (16.00) |
| | 8 | 0.551 (14.00) | 0.630 (16.00) |
| | 9 | 0.630 (16.00) | 0.551 (14.00) |
| | 10 | 0.709 (18.00) | 0.551 (14.00) |
| | 11 | 0.787 (20.00) | 0.472 (12.00) |
| 12 | 0.866 (22.00) | 0.472 (12.00) | |
| 13 | 0.945 (24.00) | 0.394 (10.00) | |
| 14 | 1.024 (26.00) | 0.394 (10.00) | |
| 15 | 1.102 (28.00) | 0.315 (8.00) | |
| 16 | 1.181 (30.00) | 0.315 (8.00) | |

Easy Mate® Chassis Cut-out Design

Patent Pending

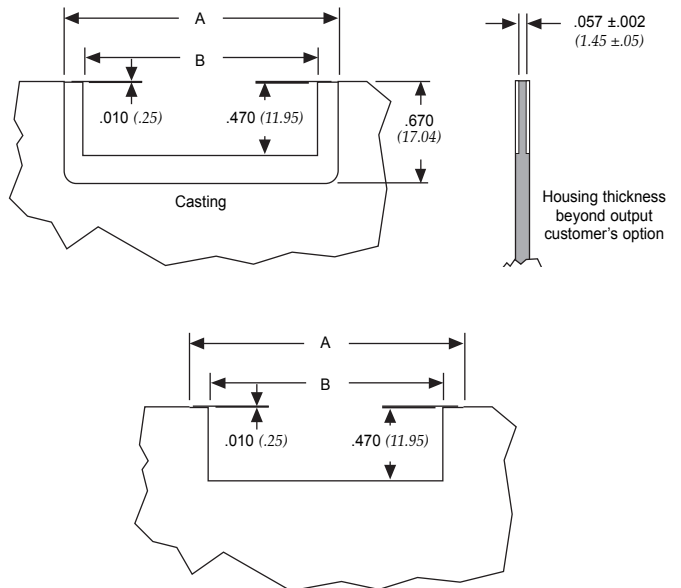

| Plate Length | A | B |
|---------------|---------------|---------------|
| 1.092 (27.74) | 1.117 (28.41) | 0.816 (20.75) |
| 1.812 (46.02) | 1.837 (46.71) | 1.535 (39.04) |

Patented
† Refers to lead configuration for part number/ordering information

Easy Mate® Jr. Filter Plates

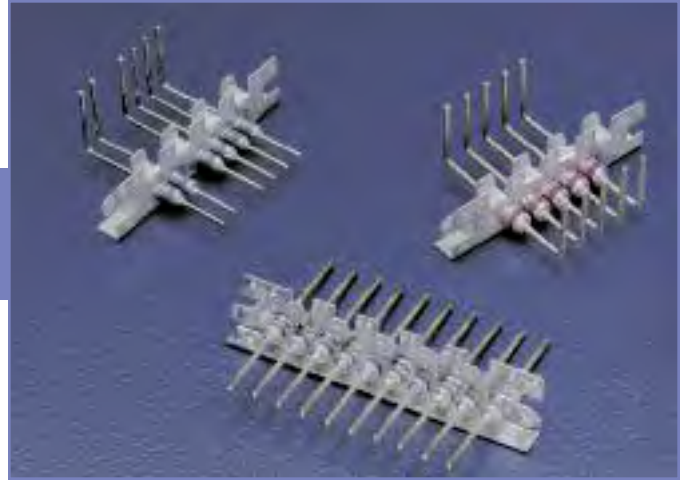

API's Spectrum Control brand has expanded its popular Easy Mate® family by adding two more package sizes. These new sizes are lower profile and facilitate installation of feed-through filters into small hardware applications such as PCS linear power amplifiers and RF transmitters. The Easy Mate® Jr. is available in two plate lengths, .990" and 1.240", and in standard (.100") and high density centers (2mm).

Easy Mate® Jr. Advantages

- Reduces installation time and overall cost
- Eliminates mounting hardware and prepwork
- Increase flexibility with standard density centers (.100") or high density centers (2mm)
- Improves overall quality and reliability
- Multiple finger ground contacts provide excellent EMI filtering from 5 MHz to 18 GHz
- Outperforms surface mount devices
- Maximize real estate on PCB
- Mixed capacitance values and schematics
- Ideal for isolation of electronic compartments
- Available in RoHS compliant versions

Mechanical Specifications

Base Plate

MaterialBeryllium copper

Base Plate

Thickness010 inches (.25mm)

Plating.....Tin,
RoHS version will be silver

Lead Material.....Copper alloy

Lead PlatingGold plate

Lead Diameter..... \varnothing .025" (.64mm)
for 0.100" centers (2.54mm)
 \varnothing .020 (.51mm)
for 0.079" centers (2.00mm)

Current Rating5 Amps for .025" \varnothing (.64mm)
3 Amps for .020" \varnothing (.51mm)

Ordering Information

Example: 52-978-1-06-B-A-2

The part number shown represents an Easy Mate® Jr. filter plate with 6 filters. Filters are C style with a capacitance value of 100pF. The plate length is .990", and the leads are bent 90° to the right side.

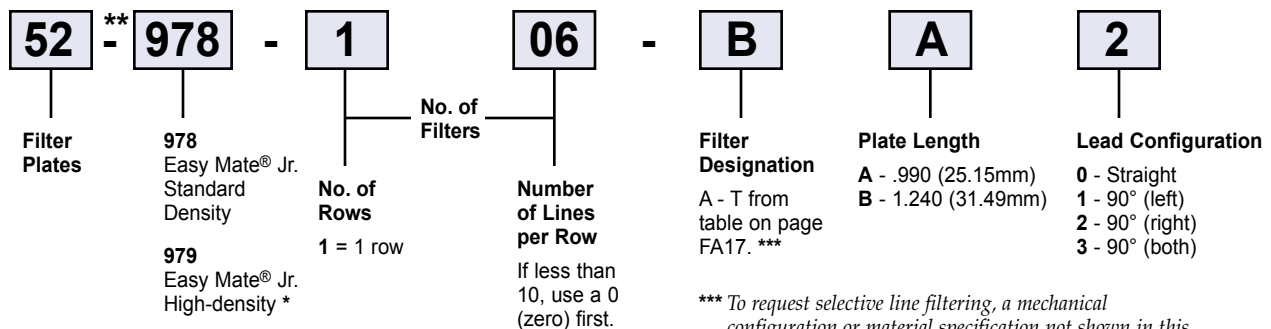

* Maximum capacitance up to 4000pF C style filter

**Replace "-" with "F" for RoHS complaint version

*** To request selective line filtering, a mechanical configuration or material specification not shown in this catalog, please complete and forward the design inquiry form on page FA18. We will review your request and provide you with a part number.

Easy Mate® Jr. Filter Plates

Dimensions: inches and (mm)

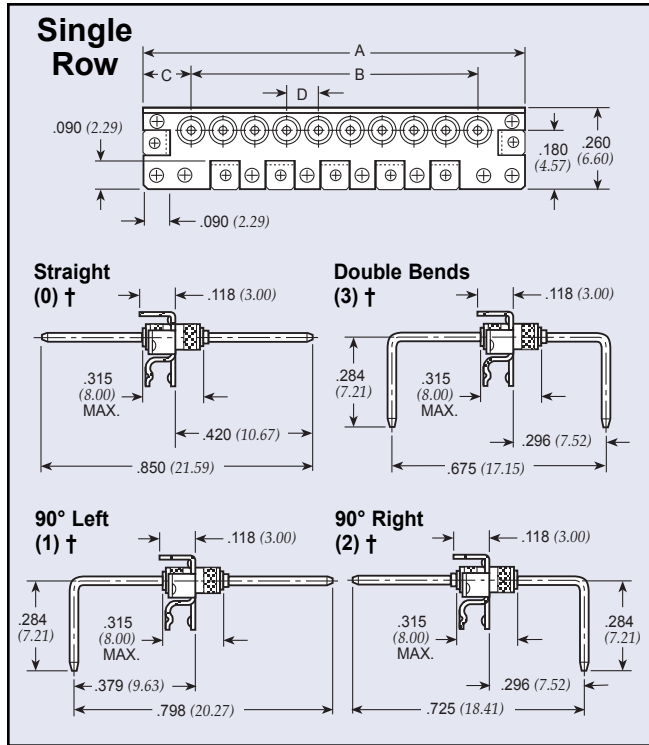

† Refers to lead configuration for part number/ordering information

Typical Mounting Application

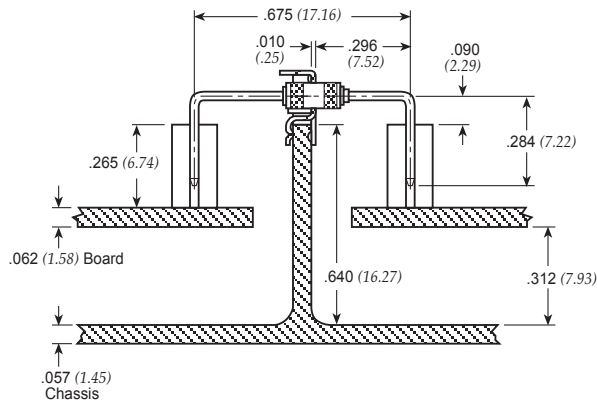

Standard Density Centers .100" (D)

| Plate length (A) | No. of filtered lines per row | 52-978-XXX-XXX | |
|------------------|-------------------------------|----------------|---------------|
| | | B | C |
| .990 (25.15) | 2 | 0.1 (2.54) | 0.395 (10.03) |
| | 3 | 0.2 (5.08) | 0.395 (10.03) |
| | 4 | 0.3 (7.62) | 0.295 (7.49) |
| | 5 | 0.4 (10.16) | 0.295 (7.49) |
| | 6 | 0.5 (12.70) | 0.195 (4.95) |
| 1.24 (31.49) | 2 | 0.1 (2.54) | 0.570 (14.48) |
| | 3 | 0.2 (5.08) | 0.470 (11.94) |
| | 4 | 0.3 (7.62) | 0.470 (11.94) |
| | 5 | 0.4 (10.16) | 0.370 (9.40) |
| | 6 | 0.5 (12.70) | 0.370 (9.40) |
| 1.24 (31.49) | 7 | 0.6 (15.24) | 0.270 (6.86) |
| | 8 | 0.7 (17.78) | 0.270 (6.86) |
| | 9 | 0.8 (20.32) | 0.170 (4.32) |
| | 10 | 0.9 (22.86) | 0.170 (4.32) |

High Density Centers 2mm (D)

| Plate length (A) | No. of filtered lines per row | 52-979-XXX-XXX | |
|------------------|-------------------------------|----------------|---------------|
| | | B | C |
| .990 (25.15) | 2 | 0.079 (2.00) | 0.417 (10.58) |
| | 3 | 0.157 (4.00) | 0.417 (10.58) |
| | 4 | 0.236 (6.00) | 0.338 (8.58) |
| | 5 | 0.315 (8.00) | 0.338 (8.58) |
| | 6 | 0.394 (10.00) | 0.259 (6.58) |
| 1.24 (31.49) | 7 | 0.472 (12.00) | 0.259 (6.58) |
| | 2 | 0.079 (2.00) | 0.580 (14.75) |
| | 3 | 0.157 (4.00) | 0.502 (12.75) |
| | 4 | 0.236 (6.00) | 0.502 (12.75) |
| 1.24 (31.49) | 5 | 0.315 (8.00) | 0.423 (10.75) |
| | 6 | 0.394 (10.00) | 0.423 (10.75) |
| | 7 | 0.472 (12.00) | 0.344 (8.75) |
| | 8 | 0.551 (14.00) | 0.344 (8.75) |
| | 9 | 0.630 (16.00) | 0.266 (6.75) |
| | 10 | 0.709 (18.00) | 0.266 (6.75) |

Easy Mate® Jr. Chassis Cut-out Design Patented

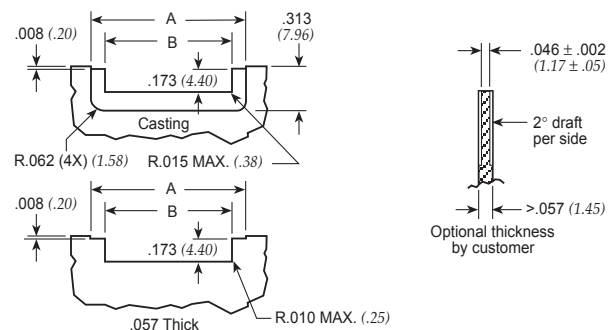

| Plate Length | A | B |
|--------------|---------------|---------------|
| .990 (25.15) | 1.015 (25.78) | 0.834 (21.18) |
| 1.24 (31.49) | 1.265 (32.13) | 1.084 (27.53) |

Bolt-in Style Filter Plates

The Bolt-in style plate provides an excellent method for electronic system interface and EMI filtering. Bolt-in filter plates are available in a variety of plate sizes and up to 74 lines per plate in high-density (2mm) and 60 pins per plate in standard density (.100"). On the larger plate sizes, API ensures structural integrity through a unique, patent pending, coining process. The drawing on page FA10 shows an electronic system utilizing Bolt-in style filter plates.



Bolt-in Filter Plate Advantages

- Eliminates the need to assemble filters into a bulkhead
- Excellent filtering from 5 MHz to 1 GHz
- Total cost savings vs. customer installed discrete filter elements
- Ideal for isolation of electronic compartments to suppress EMI
- Outperforms surface mount filters over 50 MHz
- Improved reliability
- Mixed capacitance values and schematics
- Maximize real estate on PCB
- Available in RoHS compliant versions

Ordering Information

Example: 52-970-208-BB2

The part number shown represents a Bolt-in style filter plate with 2 rows, 8 filters per row. Filters are C style with a capacitance value of 100pF. The plate length is 1.560", and the leads are bent 90° to the right side.

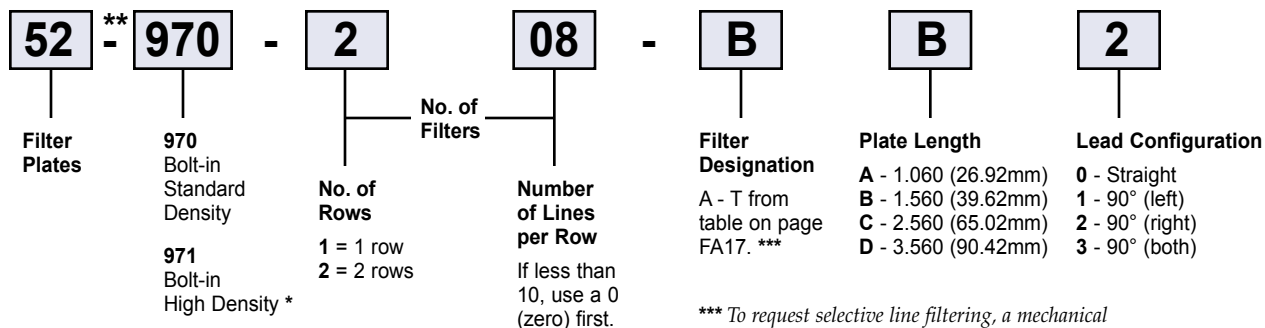

* Maximum capacitance up to 4000pF C style filter

**Replace "-" with "F" for RoHS complaint version

*** To request selective line filtering, a mechanical configuration or material specification not shown in this catalog, please complete and forward the design inquiry form on page FA18. We will review your request and provide you with a part number.

Bolt-in Style Filter Plates

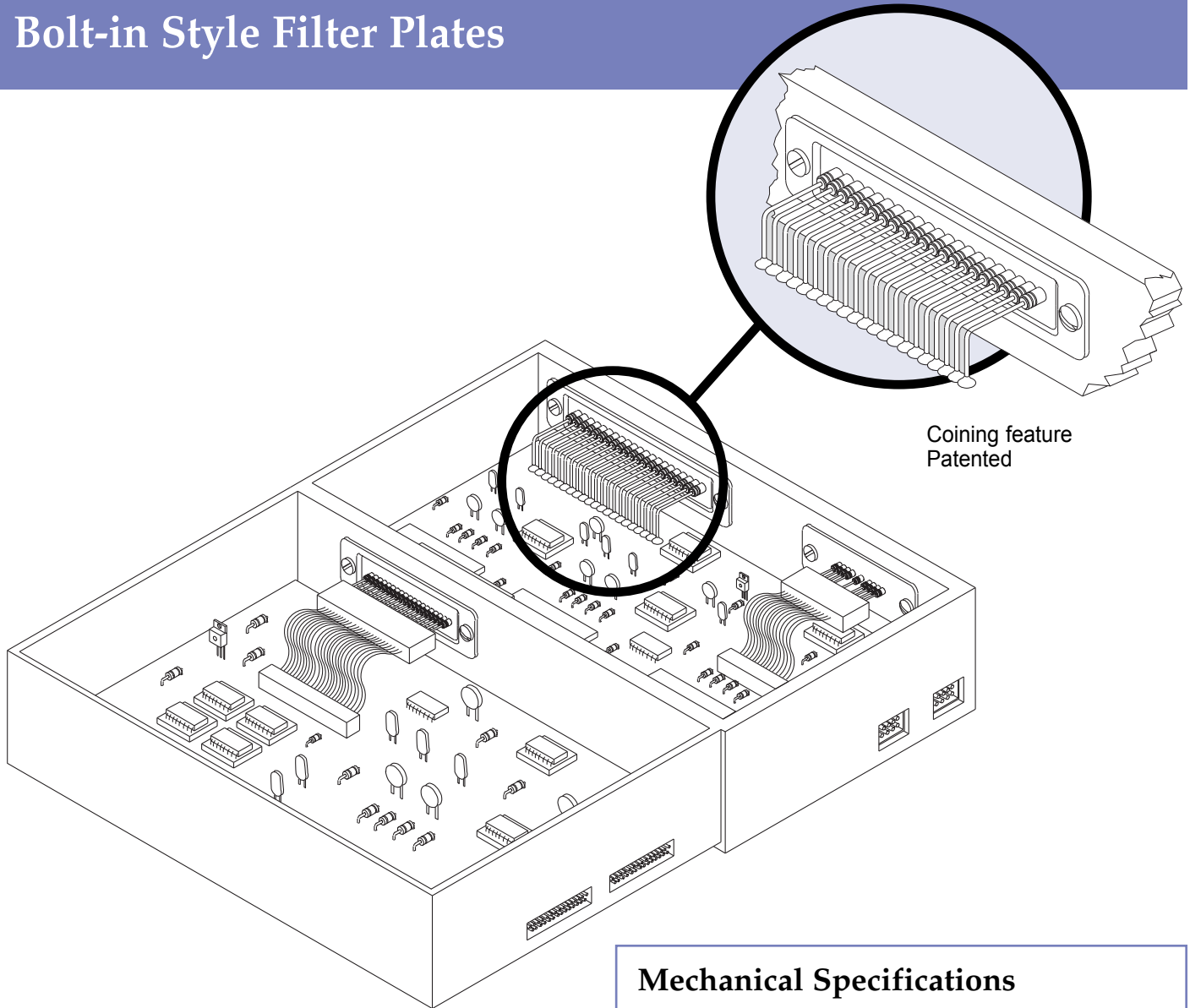

Mechanical Specifications

| | |
|-----------------------------------|---|
| Base Plate Material | Brass UNS C26000/C27000 |
| Base Plate Thickness | .020 inches (.51mm) |
| Plating | Tin, RoHS version will be silver |
| Lead Material | Copper alloy |
| Lead Plating | Gold plate |
| Lead Diameter | ø .025" (.64mm) for 0.100" centers (2.54mm) ø .020 (.51mm) for 0.079" centers (2.00mm) |
| Current Rating | 5 Amps for .025" (.64mm) ø 3 Amps for .020" (.51mm) ø |

Bolt-in Style Filter Plates

Standard Density Centers .100"

Dimensions: inches and (mm)
Lead Spacing: .100" (2.54 mm)

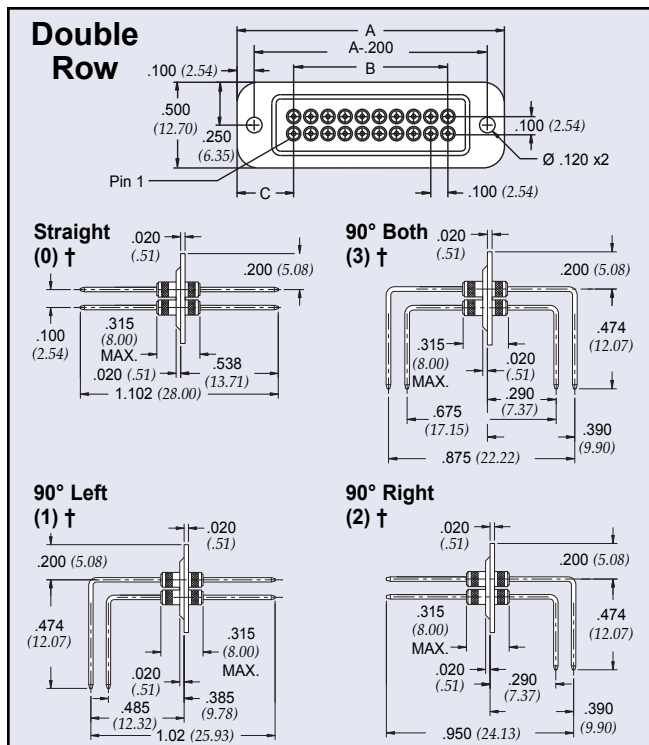
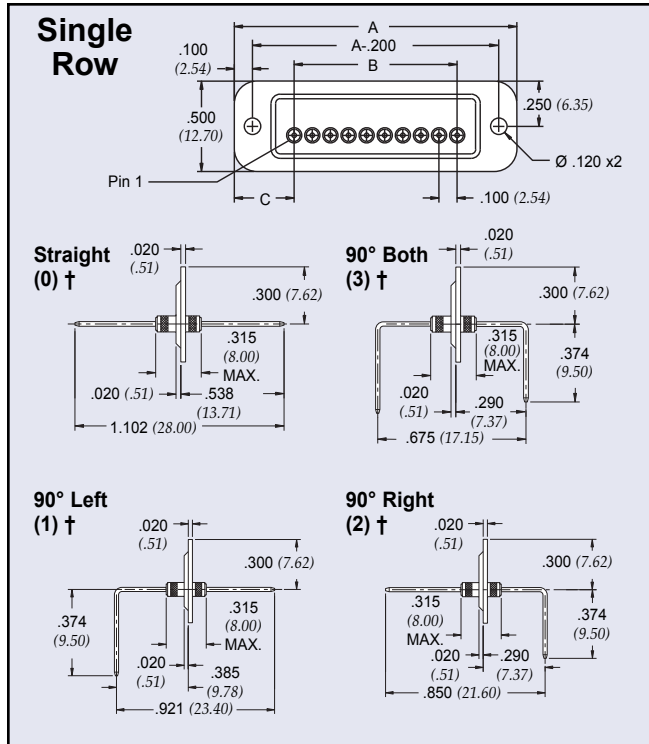

Coining feature patented

† Refers to lead configuration for part number/ordering information

| Plate length (A) | No. of filtered lines per row | 52-970-XXX-XXX | |
|--------------------|-------------------------------|----------------|--------------|
| | | B | C |
| 1.060 * (26.92) | 1 | 0 (0.00) | 0.53 (13.46) |
| | 2 | 0.1 (2.54) | 0.43 (10.92) |
| | 3 | 0.2 (5.08) | 0.43 (10.92) |
| | 4 | 0.3 (7.62) | 0.33 (8.38) |
| | 5 | 0.4 (10.16) | 0.33 (8.38) |
| 1.560 * (39.62) | 1 | 0.0 (0.00) | 0.73 (18.54) |
| | 2 | 0.1 (2.54) | 0.73 (18.54) |
| | 3 | 0.2 (5.08) | 0.63 (16.00) |
| | 4 | 0.3 (7.62) | 0.63 (16.00) |
| | 5 | 0.4 (10.16) | 0.53 (13.46) |
| | 6 | 0.5 (12.70) | 0.53 (13.46) |
| | 7 | 0.6 (15.24) | 0.43 (10.92) |
| | 8 | 0.7 (17.78) | 0.43 (10.92) |
| | 9 | 0.8 (20.32) | 0.33 (8.38) |
| | 10 | 0.9 (22.86) | 0.33 (8.38) |
| 2.560 (65.02) | 5 | 0.4 (10.16) | 1.03 (26.16) |
| | 6 | 0.5 (12.70) | 1.03 (26.16) |
| | 7 | 0.6 (15.24) | 0.93 (23.62) |
| | 8 | 0.7 (17.78) | 0.93 (23.62) |
| | 9 | 0.8 (20.32) | 0.83 (21.08) |
| | 10 | 0.9 (22.86) | 0.83 (21.08) |
| | 11 | 1.0 (25.40) | 0.73 (18.54) |
| | 12 | 1.1 (27.94) | 0.73 (18.54) |
| | 13 | 1.2 (30.48) | 0.63 (16.00) |
| | 14 | 1.3 (33.02) | 0.63 (16.00) |
| | 15 | 1.4 (35.56) | 0.53 (13.46) |
| | 16 | 1.5 (38.10) | 0.53 (13.46) |
| | 17 | 1.6 (40.64) | 0.43 (10.92) |
| | 18 | 1.7 (43.18) | 0.43 (10.92) |
| | 19 | 1.8 (45.72) | 0.33 (8.38) |
| 20 | 1.9 (48.26) | 0.33 (8.38) | |
| 3.560 (90.42) | 13 | 1.2 (30.48) | 1.13 (27.70) |
| | 14 | 1.3 (33.02) | 1.13 (27.70) |
| | 15 | 1.4 (35.56) | 1.03 (26.16) |
| | 16 | 1.5 (38.10) | 1.03 (26.16) |
| | 17 | 1.6 (40.64) | 0.93 (23.62) |
| | 18 | 1.7 (43.18) | 0.93 (23.62) |
| | 19 | 1.8 (45.72) | 0.83 (21.08) |
| | 20 | 1.9 (48.26) | 0.83 (21.08) |
| | 21 | 2.0 (50.80) | 0.73 (18.54) |
| | 22 | 2.1 (53.34) | 0.73 (18.54) |
| | 23 | 2.2 (55.88) | 0.63 (16.00) |
| | 24 | 2.3 (58.42) | 0.63 (16.00) |
| | 25 | 2.4 (60.96) | 0.53 (13.46) |
| | 26 | 2.5 (63.50) | 0.53 (13.46) |
| | 27 | 2.6 (66.04) | 0.43 (10.92) |
| 28 | 2.7 (68.58) | 0.43 (10.92) | |
| 29 | 2.8 (71.12) | 0.33 (8.38) | |
| 30 | 2.9 (73.66) | 0.33 (8.38) | |

* For plate widths 1.060 and 1.560 there will be no coining.
For these plates, increase dimensions to the right .020".
Thus, any dimension on left will be reduced by .020.

Bolt-in Style Filter Plates

High-Density Centers 2mm

Dimensions: inches and (mm)
Lead Spacing: .079" (2.00 mm)

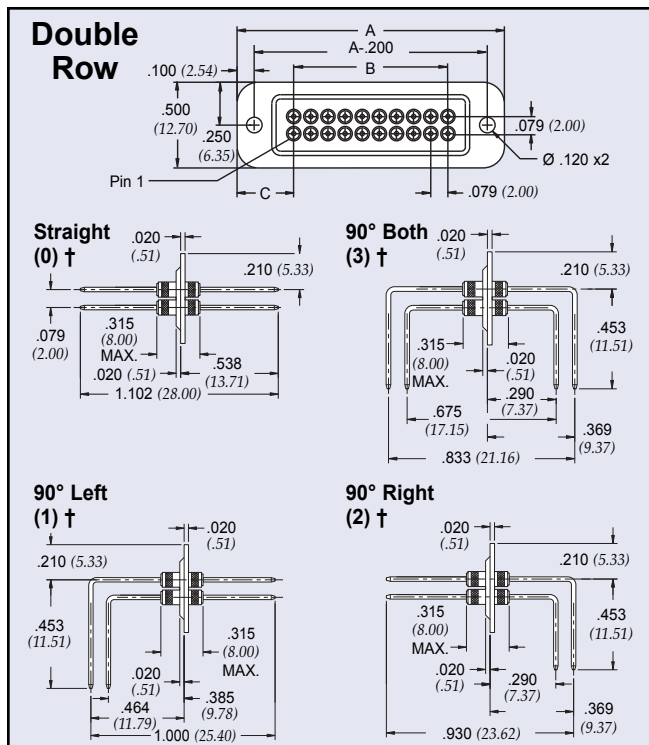
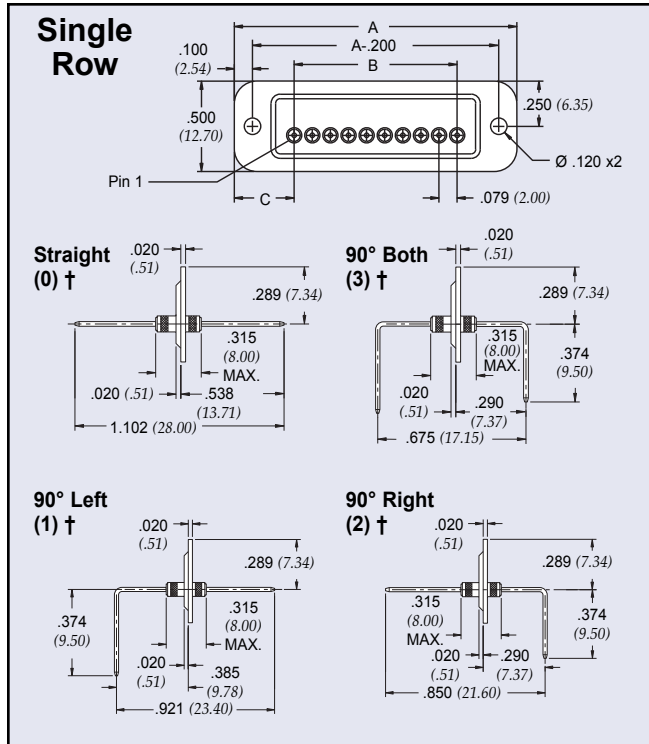

Coining feature patented
† Refers to lead configuration for part number/ordering information

| Plate length (A) | No. of filtered lines per row | 52-971-XXX-XXX | |
|--------------------|-------------------------------|----------------|---------------|
| | | B | C |
| 1.060 * (26.92) | 2 | 0.079 (2.00) | 0.487 (12.38) |
| | 3 | 0.157 (4.00) | 0.409 (10.38) |
| | 4 | 0.236 (6.00) | 0.409 (10.38) |
| | 5 | 0.315 (8.00) | 0.330 (8.38) |
| | 6 | 0.394 (10.00) | 0.330 (8.38) |
| 1.560 * (39.62) | 3 | 0.157 (4.00) | 0.662 (16.81) |
| | 4 | 0.236 (6.00) | 0.662 (16.81) |
| | 5 | 0.315 (8.00) | 0.583 (14.81) |
| | 6 | 0.394 (10.00) | 0.583 (14.81) |
| | 7 | 0.472 (12.00) | 0.504 (12.81) |
| | 8 | 0.551 (14.00) | 0.504 (12.81) |
| | 9 | 0.630 (16.00) | 0.426 (10.81) |
| 2.560 (65.02) | 10 | 0.709 (18.00) | 0.886 (22.51) |
| | 11 | 0.787 (20.00) | 0.886 (22.51) |
| | 12 | 0.866 (22.00) | 0.807 (20.51) |
| | 13 | 0.945 (24.00) | 0.807 (20.51) |
| | 14 | 1.024 (26.00) | 0.729 (18.51) |
| | 15 | 1.102 (28.00) | 0.729 (18.51) |
| | 16 | 1.181 (30.00) | 0.650 (16.51) |
| | 17 | 1.260 (32.00) | 0.650 (16.51) |
| | 18 | 1.339 (34.00) | 0.571 (14.51) |
| | 19 | 1.417 (36.00) | 0.571 (14.51) |
| | 20 | 1.496 (38.00) | 0.492 (12.51) |
| | 21 | 1.575 (40.00) | 0.492 (12.51) |
| 3.560 (90.42) | 22 | 1.654 (42.00) | 0.414 (10.51) |
| | 23 | 1.732 (44.00) | 0.414 (10.51) |
| | 24 | 1.811 (46.00) | 0.335 (8.51) |
| | 25 | 1.890 (48.00) | 0.335 (8.51) |
| | 20 | 1.496 (38.00) | 0.993 (25.22) |
| | 21 | 1.575 (40.00) | 0.993 (25.22) |
| | 22 | 1.654 (42.00) | 0.914 (23.22) |
| | 23 | 1.732 (44.00) | 0.914 (23.22) |
| | 24 | 1.811 (46.00) | 0.835 (21.22) |
| | 25 | 1.890 (48.00) | 0.835 (21.22) |
| | 26 | 1.969 (50.00) | 0.757 (19.22) |
| | 27 | 2.047 (52.00) | 0.757 (19.22) |
| | 28 | 2.126 (54.00) | 0.678 (17.22) |
| | 29 | 2.205 (56.00) | 0.678 (17.22) |
| | 30 | 2.283 (58.00) | 0.599 (15.22) |
| | 31 | 2.362 (60.00) | 0.599 (15.22) |
| | 32 | 2.441 (62.00) | 0.520 (13.22) |
| 33 | 2.520 (64.00) | 0.520 (13.22) | |
| 34 | 2.598 (66.00) | 0.442 (11.22) | |
| 35 | 2.677 (68.00) | 0.442 (11.22) | |
| 36 | 2.756 (70.00) | 0.363 (9.22) | |
| 37 | 2.835 (72.00) | 0.363 (9.22) | |

* For plate widths 1.060 and 1.560 there will be no coining.
For these plates, increase dimensions to the right .020".
Thus, any dimension on left will be reduced by .020.

Shrouded Latch Filter Plates



Shrouded Latch Filter Plates are an effective method for combining an electronic interface and EMI solution in one package. The shrouded latch incorporates the bolt-in concept filter plate with the latching feature of popular ribbon cable headers. This product is available in pin counts of 10 through 64 positions. The latch is available in a variety of standard heights.

The shrouded latch filter plate is ideal for securing and protecting the filter element from exposure to mechanical shock and vibration which could loosen the cable interface.

Shrouded Latch Filter Plate Advantages

- Available in 10 to 64 positions
- Mates to most ribbon cable connectors
- Variety of latch ejector heights available
- Pins on .100" centers
- Reliable cable retention for high vibration applications
- Mixed capacitance values and schematics available
- Excellent filtering from 5 MHz to 1 GHz and beyond
- Shroud protects filter elements from potential damage
- Available in RoHS compliant versions

Mechanical Specifications

Base Plate

Material Brass UNS
C26000/C27000

Base Plate

Thickness040" (1.0mm)

Plating Tin,
RoHS version will be silver

Shrouded Material Thermoplastic
Polyester UL94V-0

Lead Material Copper alloy

Lead Plating Gold plate

Lead Diameter \varnothing .025" (0.6mm)

Current Rating 5 Amps

Ordering Information

Example: 53-038-014-B S 1

The part number shown represents a shrouded latch filter plate with 14 filtered lines. Filters are C style with a capacitance value of 100pF. The plate has a short latch height and double shroud configuration.

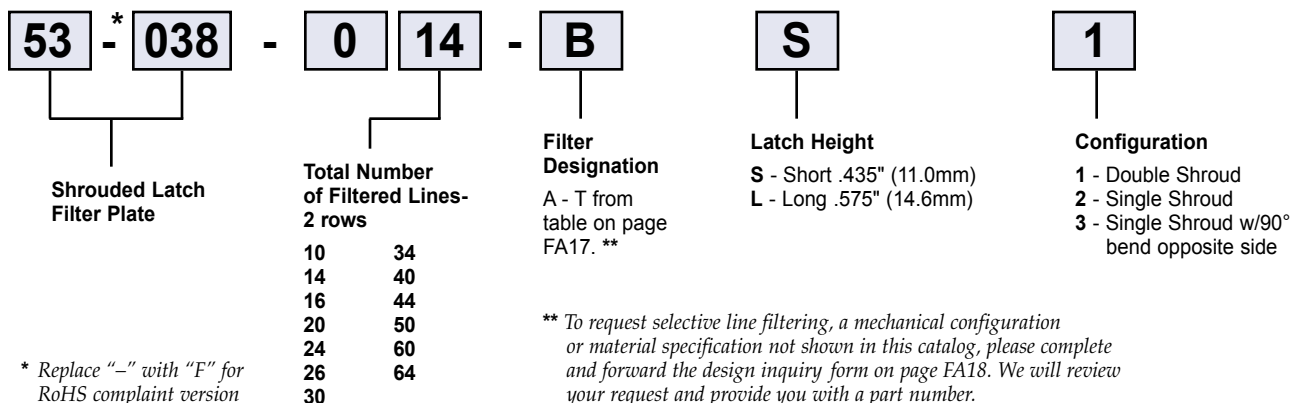

** To request selective line filtering, a mechanical configuration or material specification not shown in this catalog, please complete and forward the design inquiry form on page FA18. We will review your request and provide you with a part number.

Shrouded Latch Filter Plates

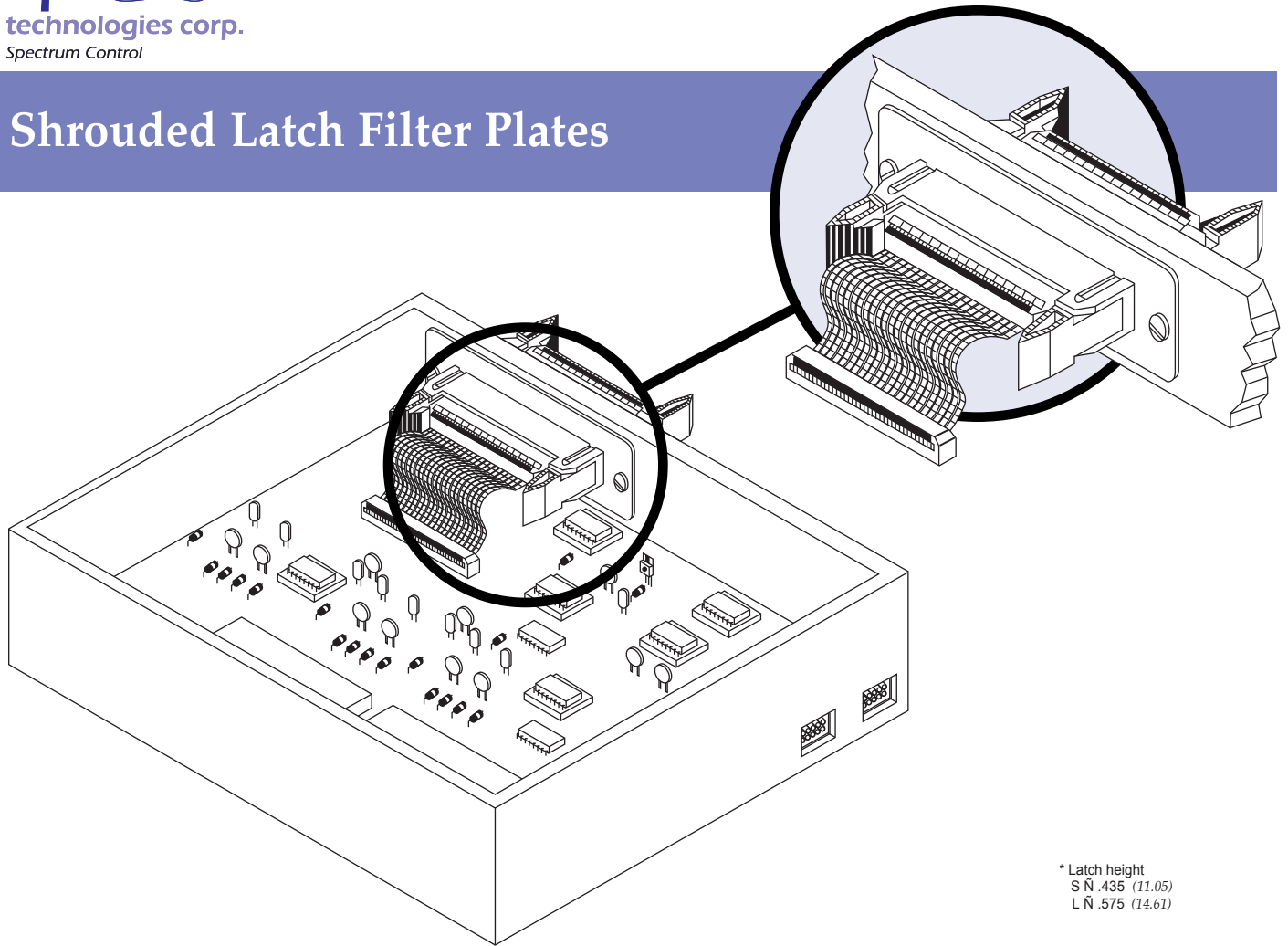

* Latch height
S N .435 (11.05)
L N .575 (14.61)

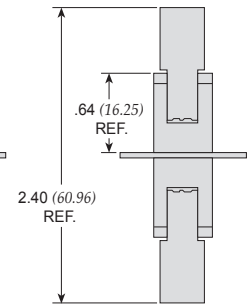
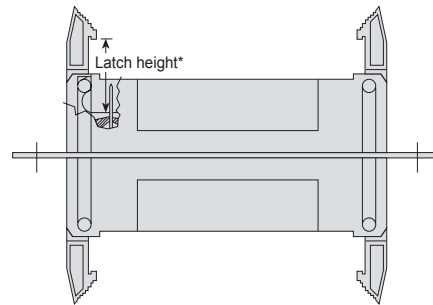
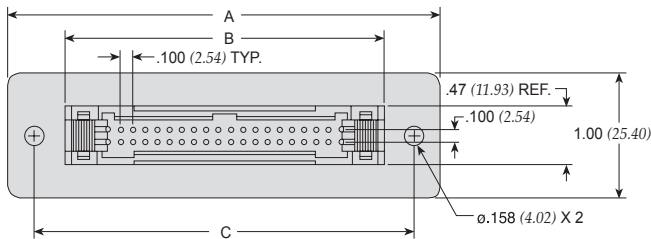

| Part Number | Number of Circuits | A | | B | | C | |
|-----------------|--------------------|------|---------|------|--------|------|---------|
| | | in | (mm) | in | (mm) | in | (mm) |
| 53-038-010-XXX* | 10 | 2.00 | (50.8) | 1.10 | (27.9) | 1.58 | (40.1) |
| 53-038-014-XXX | 14 | 2.20 | (55.9) | 1.30 | (33.0) | 1.78 | (45.2) |
| 53-038-016-XXX* | 16 | 2.30 | (58.4) | 1.40 | (35.6) | 1.88 | (47.8) |
| 53-038-020-XXX* | 20 | 2.50 | (63.5) | 1.60 | (40.6) | 2.08 | (52.8) |
| 53-038-024-XXX | 24 | 2.70 | (68.6) | 1.80 | (45.7) | 2.28 | (57.9) |
| 53-038-026-XXX | 26 | 2.80 | (71.1) | 1.90 | (48.3) | 2.38 | (60.5) |
| 53-038-030-XXX | 30 | 3.00 | (76.2) | 2.10 | (53.3) | 2.58 | (65.5) |
| 53-038-034-XXX | 34 | 3.20 | (81.3) | 2.30 | (58.4) | 2.78 | (70.6) |
| 53-038-040-XXX* | 40 | 3.50 | (88.9) | 2.60 | (66.0) | 3.08 | (78.2) |
| 53-038-044-XXX | 44 | 3.70 | (94.0) | 2.80 | (71.1) | 3.28 | (83.3) |
| 53-038-050-XXX* | 50 | 4.00 | (101.6) | 3.10 | (78.7) | 3.58 | (90.9) |
| 53-038-060-XXX | 60 | 4.50 | (114.3) | 3.60 | (91.4) | 4.08 | (103.6) |
| 53-038-064-XXX* | 64 | 4.70 | (119.4) | 3.80 | (96.5) | 4.28 | (108.7) |

* Indicates standard sizes

Dimensions in inches (mm)

Custom Filter Plates

High Volume Industrial

As a long-term producer of filter plates for industrial applications, API Technologies understands the cost requirements of this market. In turn, we have established a program to develop and manufacture custom designed filter plates for cost sensitive industrial applications.

We have engineered a variety of capacitive only filter elements that provide excellent RF isolation from 5 MHz to 1 GHz and beyond. To determine the available capacitance values, contact API. Our technical staff will work with you to develop a solution that meets your system and budget needs.

Military/High Reliability

Improving the electromagnetic compliance (EMC) of electronic systems is an area of intense focus within the defense and avionics industries. To achieve this goal, many companies are replacing discrete filter elements and surface mount filters with feed-through filter plate assemblies for higher frequency isolation.

API will custom design a filter plate that meets your size, material and filtering requirements. We are capable of providing stringent testing and analysis of our filter plate assemblies to MIL-F-15733 and MIL-F-28861.

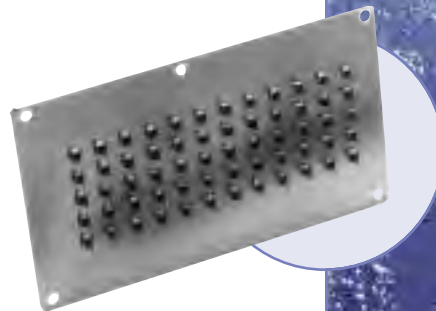
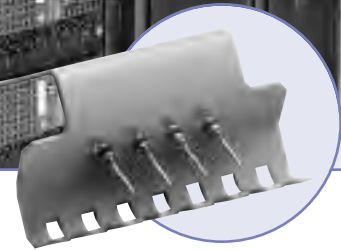
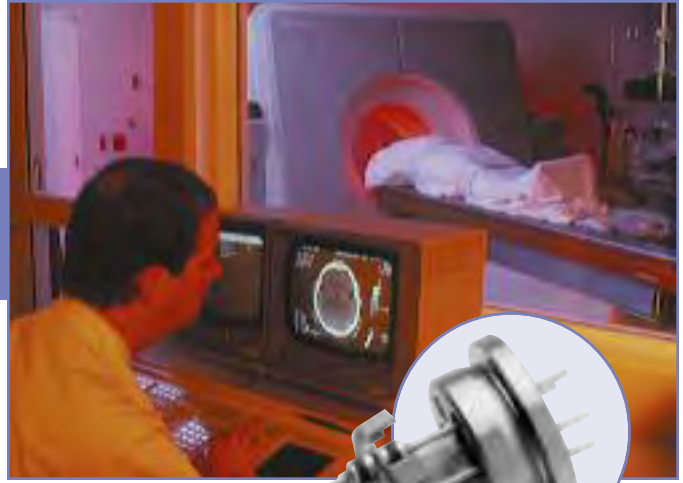

Custom Capabilities

In addition to our custom filter plates, API Technologies' Spectrum Control brand offers a number of value-added features designed to complement your manufacturing operation. Our marketing and engineering staff will evaluate your design or manufacturing parameters and develop a filter solution which provides increased filtering performance economically.

API Capabilities

- Custom assemblies with varying cable lengths and impedances for high clock speeds associated with digital electronics
- Integrate a filter solution with other components to ensure a completely functional device
- Perform EMC evaluations on your equipment, recommending proper placement of EMI/RFI filtering components

Filtered Headers

Replace the unfiltered connector on your PC board with API's low cost filtered header. This innovative new product allows you to meet EMC emissions and susceptibility standards with minimal or no board change.

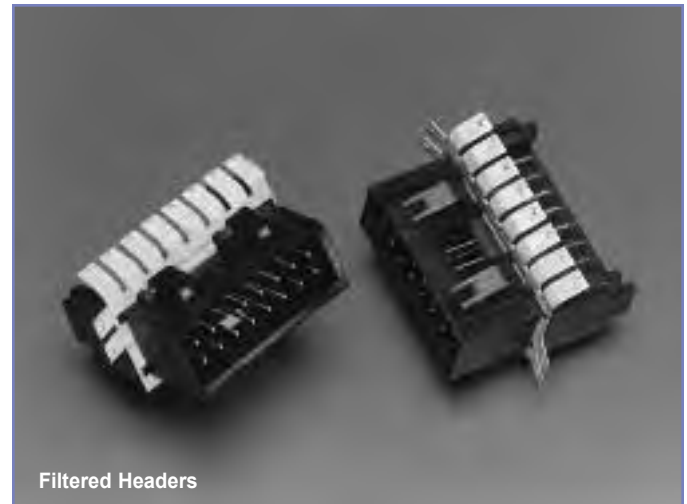
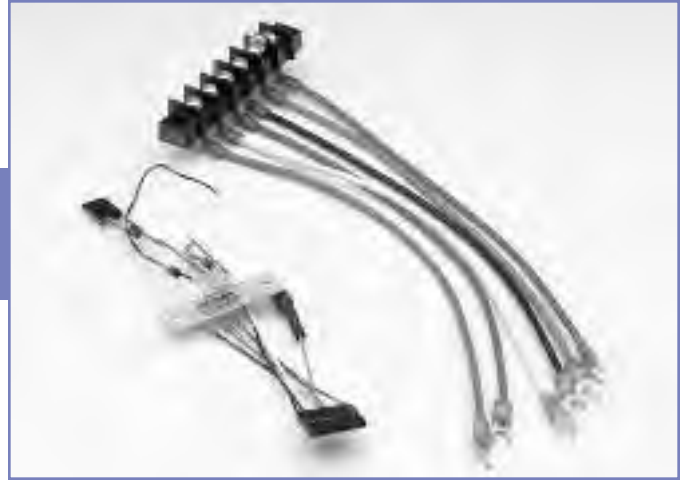

Flat Conductor Cables

Flat conductor cables are often selected as an effective method of interconnection. API can save you time and money by installing conductor cables to your filter plates. Flat conductor cables are available in varying lengths, conductor counts, and in several termination configurations.

Lead Stabilizer

API has developed a filter plate lead stabilizer bar to protect leads during installation and ensure proper alignment to PCB.

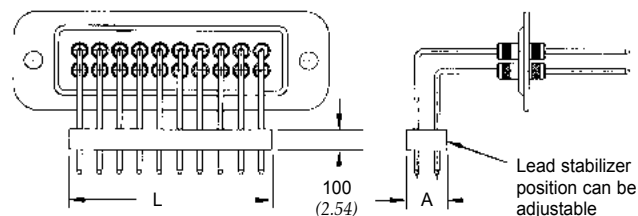
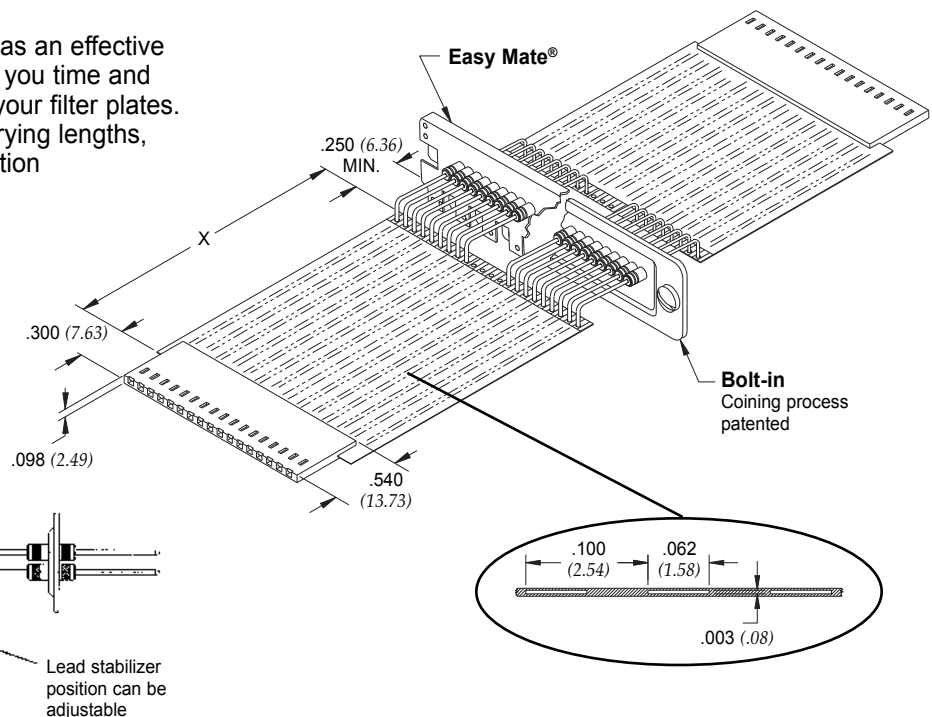

Filter Selection

EMI Filter Performance

The electrical characteristics table and insertion loss graphs indicate the performance of feed-through capacitors and Pi type filters. Utilize this information to specify the EMI filtering components included in your filter plate.

Custom Filtering

API Technologies' Spectrum Control line of filter plates are engineered to accommodate selective line filtering. Several different types of filters may be specified in a single, easy to install filter plate, allowing you to facilitate a wide range of filtering requirements.

For selective line filtering, provide a sketch indicating the filters and positions required. The example below represents a 10 pin, 2 row plate with six 1000 pF feed-through capacitors and four 1700 pF Pi type filters.

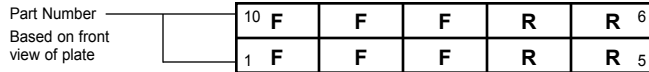

Typical Insertion Loss

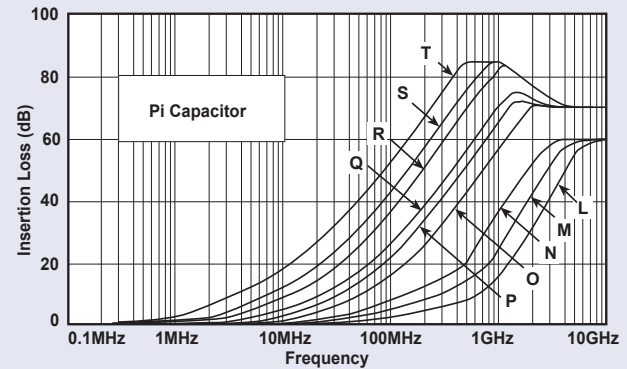
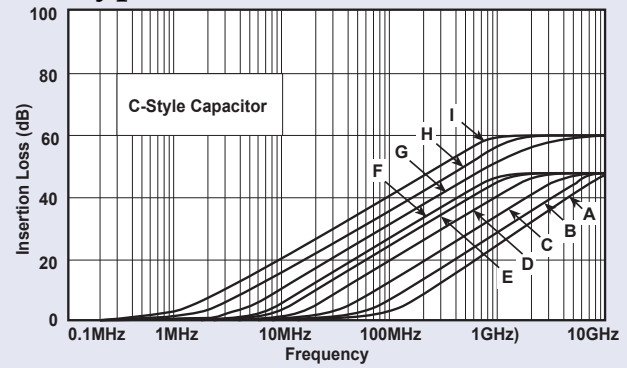

Above curves represent application of proper grounding fundamentals, for assistance consult with API.

| Filter Designation | Filter** Circuits | Capacitance | | 3 dB Max Cut-off Frequency (MHz)* | Working Voltage DC -55°C to +125°C | Minimum Insertion Loss - Decibels (dB) 50 ohm system per MIL-STD-220 (no load) | | | | | | | |
|--------------------|-------------------|-------------|-----------|-----------------------------------|------------------------------------|--|--------|--------|--------|---------|---------|---------|-------|
| | | Value | Tolerance | | | 5 MHz | 10 MHz | 20 MHz | 50 MHz | 100 MHz | 200 MHz | 500 MHz | 1 GHz |
| A | C | 68 pF | ±20% | 77 | 100V | — | — | — | — | — | 3 | 10 | 16 |
| B | | 100 pF | ±20% | 53 | 100V | — | — | — | — | 1 | 6 | 14 | 19 |
| C | | 135 pF | +100/-0% | 23 | 100V | — | — | — | 1 | 5 | 10 | 16 | 20 |
| D | | 470 pF | ±20% | 11 | 100V | — | — | 2 | 7 | 13 | 19 | 25 | 27 |
| E | | 820 pF | ±20% | 6 | 100V | — | 2 | 6 | 12 | 18 | 24 | 30 | 33 |
| F | | 1000 pF | ±20% | 5 | 100V | — | 3 | 7 | 14 | 20 | 26 | 32 | 35 |
| G | | 1500 pF | ±20% | 3.5 | 100V | 1 | 4 | 10 | 16 | 22 | 29 | 36 | 37 |
| H | | 2500 pF | +100/-0% | 1.3 | 100V | 5 | 11 | 17 | 23 | 29 | 35 | 38 | 40 |
| I | | 4000 pF | +100/-0% | .8 | 100V | 9 | 15 | 21 | 27 | 34 | 38 | 42 | 46 |
| J | Insulated | 10 pF | Max. | 635 | 100V | — | — | — | — | — | — | — | |
| K | Grounded Insert | | | | | — | — | — | — | — | — | — | |
| L | Pi | 68 pF | ±20% | 65 | 100V | — | — | — | — | 1 | 6 | 17 | 23 |
| M | | 100 pF | ±20% | 46 | 100V | — | — | — | — | 2 | 9 | 22 | 28 |
| N | | 135 pF | +100/-0% | 25 | 100V | — | — | — | 1 | 6 | 17 | 26 | 34 |
| O | | 470 pF | ±20% | 11 | 100V | — | — | — | 9 | 18 | 22 | 36 | 43 |
| P | | 820 pF | ±20% | 6 | 100V | — | — | 4 | 13 | 23 | 31 | 45 | 52 |
| Q | | 1000 pF | ±20% | 5 | 100V | — | 2 | 7 | 16 | 24 | 36 | 51 | 59 |
| R | | 1700 pF | +100/-0% | 1.9 | 100V | 1 | 6 | 14 | 28 | 35 | 49 | 64 | 69 |
| S | | 2500 pF | +100/-0% | 1.3 | 50V | 4 | 9 | 16 | 28 | 41 | 54 | 70 | 70 |
| T | | 5000 pF | +100/-0% | .7 | 100V | 9 | 15 | 28 | 41 | 53 | 66 | 70 | 70 |

* 3 dB cut-off frequency calculated at the maximum capacitance.

** For Hi-Density centers (2 mm) only C style filters are available, to a maximum of 4000pF.

All high density capacitors are 50 volts @ 125°C.

Custom Filter Plates

Filter Plate Design Inquiry Form

General Information

| | |
|-----------------|-------------------------|
| Customer: _____ | Location: _____ |
| Address: _____ | |
| City: _____ | State: _____ Zip: _____ |
| Contact: _____ | Title: _____ |
| Phone: _____ | Fax: _____ |

Project Information

| | | |
|--|-----------------------|---------------------|
| Project name: _____ | Annual usage: _____ | Target price: _____ |
| Intended application: _____ | Quote quantity: _____ | |
| Function of circuit filter is used in: _____ | Target cost: _____ | |

Functional Detail NOTE: Bold lettering represents standard, readily available material (Circle the appropriate parameters needed)

| <u>Lead Diameter</u> | | | | <u>Total Lead Length</u> | | | <u>Lead Material</u> | | <u>Lead Plating</u> | | | |
|---|---------------|-----------------------------|--------|--------------------------|-------|------------------------------|------------------------|--------|---------------------|--------------|--------------|--------|
| 0.020" | 0.025" | 0.032" | 0.040" | 0.700" | 1.00" | 1.102" | Phosphor Bronze | Copper | Gold | Tin | Silver | |
| Base Plate Material | | | | | | | | | | | | |
| Brass UNS C26000/C27000 Cold Rolled Steel (CRS) UNS G10080/G10180 Aluminum UNS A93003/A96061 Beryllium Copper* <small>* For Beryllium Copper, ask about our new "Easy Mate[®]" Plate</small> | | | | | | | | | | | | |
| <u>Plate Thickness (± 0.002")</u> | | | | | | <u>Plating of Base Plate</u> | | | | | | |
| (0.010" for Easy Mate[®]Jr.) | | (0.020" for Bolt-in) | | | | 0.026" | 0.033" | 0.041" | Tin | Silver | 90/10 Solder | Nickel |
| (0.012" for Easy Mate[®]) | | | | | | | | | | | | |
| <u>Center-to-Center Spacing</u> | | | | | | Standard (inch): | | | 0.079 | 0.100 | | |
| (Not all capacitances available on all centers) | | | | | | Metric (mm): | | | 2 | 2.54 | | |

Detailed Sketch and Comments Area

Include Mounting Detail

Barrier Strip Filtered Terminal Blocks

The barrier strip filtered terminal block is designed to provide excellent EMI/RFI filtering of AC and DC power lines and control lines. This terminal block is available in various sizes, with terminals for soldering or spade lugs. Application examples include filtering power supplies in telecommunications equipment, metering, industrial controls, instrumentation and EDP equipment.

Features

- UL recognized and CSA approved for DC voltages
- E133076, UL 1059
- LR92537, CSA STD 22.2 N°158-1987 and ECN584B
- Filter element provides high insertion loss for EMI/RFI filtering of AC and DC power and control lines
- Rugged construction provides protection to filtering element; especially useful for repeated changes in wiring or field connections
- 2 to 6 terminals available (combine if larger number of terminals needed)
- Cost-effective solution for industrial interconnection EMI filtering problems
- Termination options available: straight lead, male or female disconnects, pigtail (12 AWG = 0.081" (2.05mm); 22 AWG = 0.025" (0.64mm))
- Available in RoHS compliant versions

Circuit Schematic

Pi Filter

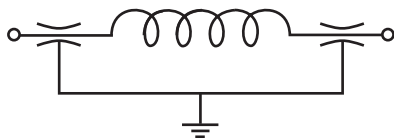

Ordering Information

Example: **52-160-006-A AOO**

The part number shown represents a barrier strip terminal block with six terminals and rated for 20 Amps. Male disconnects (.250") are the method of termination.

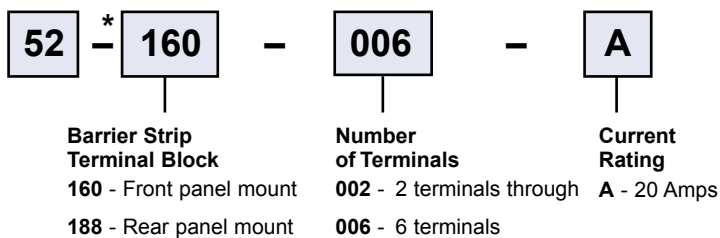

For instructions on soldering to filter terminals, please refer to page FA4 in filter plate section.

* Replace "-" with "F" for RoHS complaint version



Mechanical Specifications

- Center Spacing438" (11.1 mm)
- Wire Size AWG #12 max for 20A
- Screw Size 20A - #6-32, zinc-plated phillslot screws
- Molded Material Black, UL rated 94VO thermoplastic
- Tightening Torque 9 in.-lbs. max.
- Terminal Brass, tin-plated

Electrical Specifications

- Operating Temperature -55° C to 105° C
- Working Voltage 100VDC
- Capacitance 2,500 pF to 5,200 pF
- Dielectric
- Withstanding Voltage 1700VDC
- Current Rating 20A
- D.C. Resistance01 ohms max.

Typical Loss (dB) In 50 Ohm Circuit

| Frequency | Insertion Loss (dB) |
|-----------|---------------------|
| 30 MHz | 22 |
| 50 MHz | 32 |
| 100 MHz | 48 |
| 300 MHz | 70 |
| 500 MHz | 75 |
| 1000 MHz | 75 |

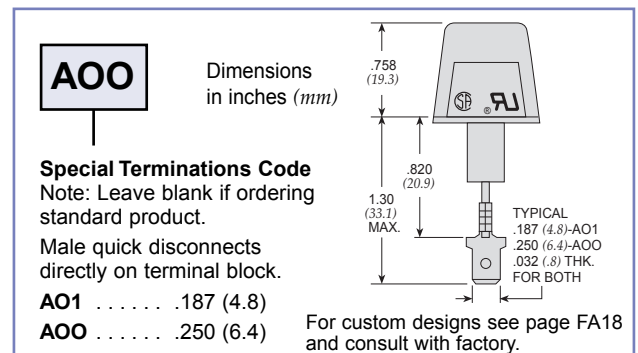

Barrier Strip Filtered Terminal Blocks

Front panel mount

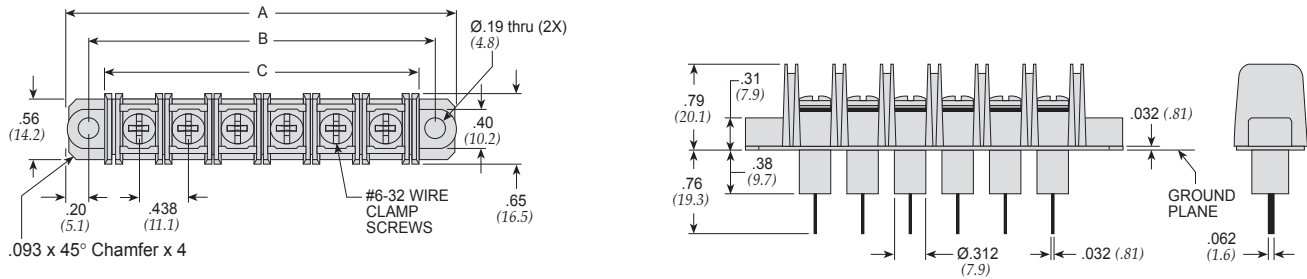

20 Amps

Dimensions in inches (mm)

| Part Number | Number of Circuits | in. A (mm) | in. B (mm) | in. C (mm) |
|----------------|--------------------|-------------|-------------|-------------|
| € 52-160-002-A | 2 | 1.71 (43.4) | 1.31 (33.3) | 1.02 (25.9) |
| 52-160-003-A | 3 | 2.15 (54.6) | 1.75 (44.5) | 1.46 (37.1) |
| 52-160-004-A | 4 | 2.59 (65.8) | 2.19 (55.6) | 1.90 (48.3) |
| 52-160-005-A | 5 | 3.02 (76.7) | 2.62 (66.5) | 2.32 (58.9) |
| 52-160-006-A | 6 | 3.46 (87.9) | 3.06 (77.7) | 2.77 (70.4) |

€ Also available through API's authorized European distributors/agents.

Rear panel mount

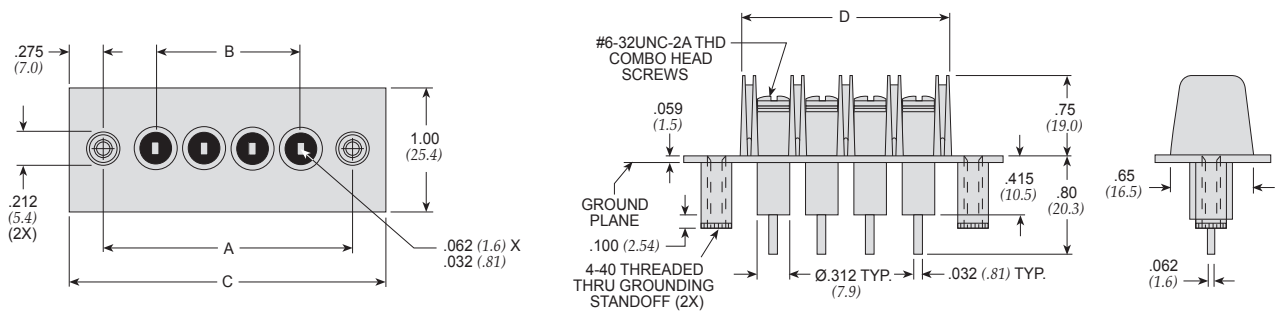

20 Amps

Dimensions in inches (mm)

| Part Number | Number of Circuits | in. A (mm) | in. B (mm) | in. C (mm) | in. D (mm) |
|--------------|--------------------|-------------|--------------|-------------|-------------|
| 52-188-002-A | 2 | 1.31 (33.3) | .438 (11.1) | 1.86 (47.3) | 1.02 (25.9) |
| 52-188-003-A | 3 | 1.75 (44.4) | .875 (22.2) | 2.30 (58.4) | 1.46 (37.1) |
| 52-188-004-A | 4 | 2.19 (55.6) | 1.313 (33.3) | 2.74 (69.5) | 1.90 (48.3) |
| 52-188-005-A | 5 | 2.62 (66.6) | 1.750 (44.4) | 3.17 (80.6) | 2.32 (58.9) |
| 52-188-006-A | 6 | 3.06 (77.7) | 2.188 (55.6) | 3.61 (91.7) | 2.77 (70.4) |

250 Volt AC Rated Filtered Terminal Blocks

API Technologies' Spectrum Control line of filtered terminal block provides superior EMI/RFI filtering of AC power and control lines. This terminal block is available in various sizes, with terminals for soldering, spade lugs, or wire pigtails. Termination options available: straight lead male or female disconnects, or wire pigtails in lengths to your specification.

Features

- UL recognized and CSA approved for AC voltages.
- E133076, UL 1059.
- LR92537, CSA STD 22.2 N°158-1987 and ECN584B.
- Termination options available: straight lead, male or female disconnects, pigtail (12 AWG-22 AWG).



Applications

- Metering equipment
- Programmable controllers
- Industrial process control
- Heavy equipment controls
- Power supplies
- Regulators
- Surge sensing equipment
- Power factor correction
- Telecommunications power management, ATM, Sonet, etc.
- Medical equipment

Specifications

ELECTRICAL

- Operating Temperature:* -55° C to +105° C
Voltage Rating: 250VAC
Current Rating: 20 Amps
Wire Range: 12-22AWG
Torque: 9 lb-in.
Capacitance: 2000pF to 5200pF
Dielectric Withstanding Voltage: 1500VAC @ 25° C

MECHANICAL

- Center Spacing:* .438" (11.1 mm)
Wire Size: AWG #12 max. for 20 Amp
Screw Size: 20A - #6-32, zinc plated philslot
Molded Material: UL rated 94VO polyamide
Tightening Torque: 9 in.-lbs. max.
Terminal Options: straight lead, male or female disconnects, pigtail

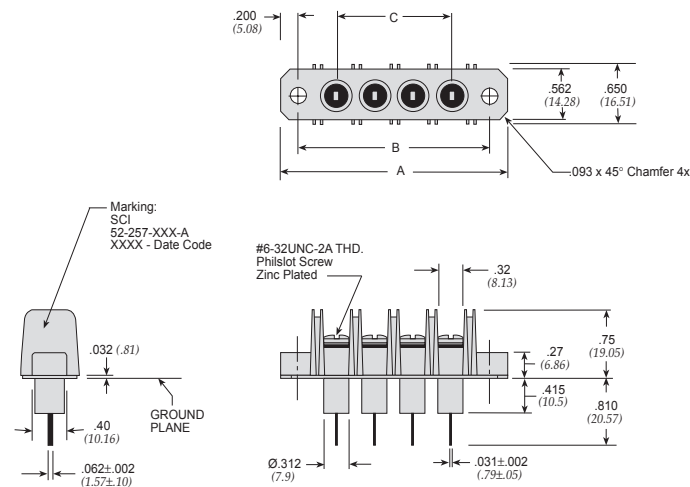

| Part Number | Number of Circuits | in. A (mm) | in. B (mm) | in. C (mm) |
|-------------|--------------------|-------------|-------------|-------------|
| 52-257-002 | 2 | 1.71 (43.4) | 1.31 (33.3) | 1.02 (25.9) |
| 52-257-003 | 3 | 2.15 (54.6) | 1.75 (44.5) | 1.46 (37.1) |
| 52-257-004 | 4 | 2.59 (65.8) | 2.19 (55.6) | 1.90 (48.3) |
| 52-257-005 | 5 | 3.02 (76.7) | 2.62 (66.5) | 2.32 (58.9) |
| 52-257-006 | 6 | 3.46 (87.9) | 3.06 (77.7) | 2.77 (70.4) |

Dimensions in inches (mm)

PCB Mount Filtered Terminal Blocks



The PCB mount filtered terminal block is designed to provide excellent EMI/RFI filtering of low voltage DC power lines and control lines. These new terminal blocks use a unique screw clamp system with a wire protector which provides for quick and easy installation. API's Spectrum Control line of PCB Mount terminal blocks can be used for a variety of power supply filtering applications in telecommunications equipment, metering, industrial controls, instrumentation and EDP equipment.

Features

- Filter element provides high insertion loss for EMI/RFI filtering of DC power and control lines
- Rugged construction provides protection to filtering element; especially useful for repeated changes in wiring or field connections
- 2 to 12 terminals available (combine if larger number of terminals needed)
- Quick and easy PCB installation and maintenance
- Cost-effective solution for industrial interconnection EMI filtering problems
- Selectively loaded filter pins to economically meet exact filtering requirements
- Available with European (5 mm) or US (.200") pin spacing
- Available in RoHS compliant versions

Circuit Schematic

C Filter

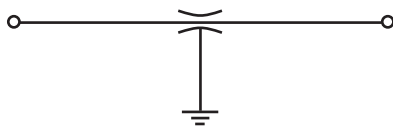

Ordering Information

Example: **52-227-006-L**

The part number shown represents a low profile PCB mount terminal block for thru-hole grounding with six terminals (US spacing).

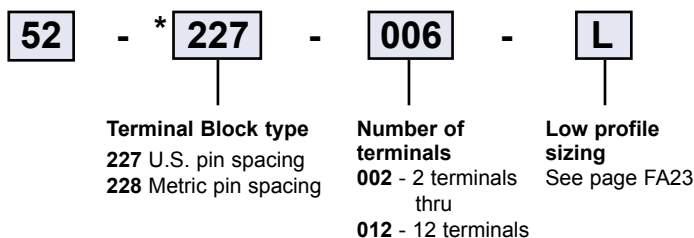

* Replace "-" with "F" for RoHS complaint version

Mechanical Specifications

- Center Spacing* US .200: (5.08 mm)
EURO .197" (5 mm)
- Wire Size* AWG 12 through 26
- Screw Material* Steel, zinc chromate plate
- Recommended PCB Hole Diameter* 0.05" (1.30 mm) contact hole
- Molded Material* UL rated 94VO polyamide
- Tightening Torque* 2.5 in.-lbs. max.
- Terminal* Brass, tin-plated

Electrical Specifications

- Operating Temperature* . . -40° C to 80° C
- Working Voltage* 100VDC
- Capacitance* 2500 pF +80% / -20%
- Dielectric Withstanding Voltage* . . . 707VDC
- Current Rating* 12 Amps max.
- D.C. Resistance* 0.01 ohms max.

Typical Loss (dB) In 50 Ohm Circuit

| Frequency | Insertion Loss (dB) |
|-----------|---------------------|
| 10 MHz | 10.4 |
| 50 MHz | 23.9 |
| 100 MHz | 29.9 |
| 500 MHz | 43.9 |
| 1000 MHz | 49.9 |

PCB Mount Filtered Terminal Blocks

US Pin Spacing

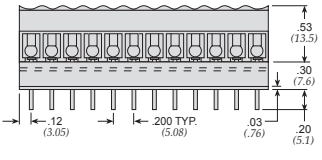
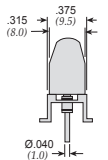
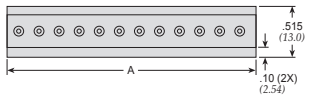
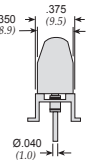
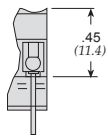
| Part Number | Number of Circuits | A | |  | Low Profile To order add -L- after part number.  |
|-------------|--------------------|------|--------|--|--|
| in. | (mm) | | | | |
| 52-227-002 | 2 | .44 | (11.2) |  <p>For effective filtering, the ground plane must be soldered to the printed circuit board.</p>  |  |
| 52-227-003 | 3 | .64 | (16.3) | | |
| 52-227-004 | 4 | .84 | (21.4) | | |
| 52-227-005 | 5 | 1.04 | (26.5) | | |
| 52-227-006 | 6 | 1.24 | (31.5) | | |
| 52-227-007 | 7 | 1.44 | (36.6) | | |
| 52-227-008 | 8 | 1.64 | (41.7) | | |
| 52-227-009 | 9 | 1.84 | (46.8) | | |
| 52-227-010 | 10 | 2.04 | (51.9) | | |
| 52-227-011 | 11 | 2.24 | (57.0) | | |
| 52-227-012 | 12 | 2.44 | (62.0) | | |

Dimensions in inches (mm)

Metric Pin Spacing

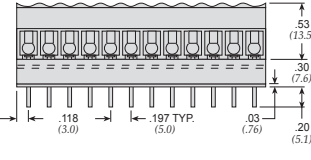
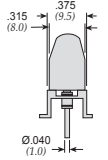
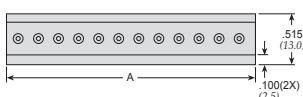
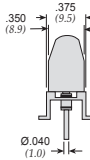
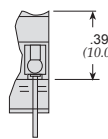
| Part Number | Number of Circuits | A | |  | Low Profile To order add -L- after part number.  |
|-------------|--------------------|------|--------|--|--|
| in. | (mm) | | | | |
| 52-228-002 | 2 | .43 | (10.9) |  <p>For effective filtering, the ground plane must be soldered to the printed circuit board.</p>  |  |
| 52-228-003 | 3 | .63 | (16.0) | | |
| 52-228-004 | 4 | .83 | (21.1) | | |
| 52-228-005 | 5 | 1.02 | (25.9) | | |
| 52-228-006 | 6 | 1.22 | (31.0) | | |
| 52-228-007 | 7 | 1.42 | (36.1) | | |
| 52-228-008 | 8 | 1.61 | (40.9) | | |
| 52-228-009 | 9 | 1.81 | (46.0) | | |
| 52-228-010 | 10 | 2.00 | (50.8) | | |
| 52-228-011 | 11 | 2.20 | (55.9) | | |
| 52-228-012 | 12 | 2.40 | (61.0) | | |

Dimensions in inches (mm)

Custom Filtered Arrays

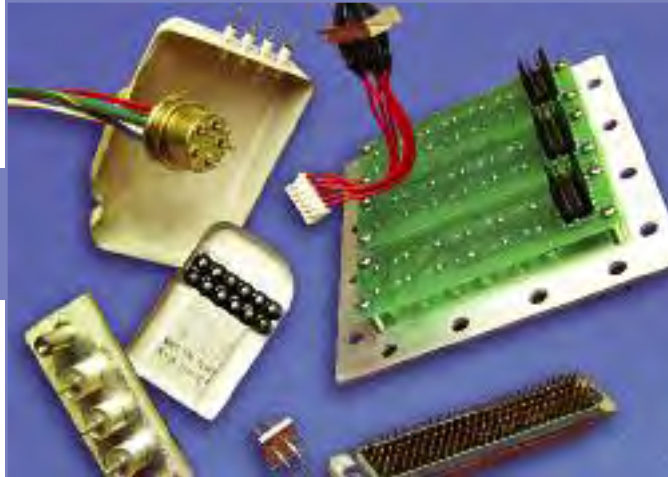

API Technologies' Spectrum Control brand will custom design a filter plate or terminal block that meets your size, material and filtering requirements. We have engineered a variety of capacitive only filter elements that provide excellent RF isolation from 5 MHz to 1 GHz and beyond. In addition, we are capable of providing stringent testing and analysis of our filter plate or terminal block assemblies to MIL-F-15733 and MIL-F-28861.

In addition to our standard and custom filter plates and terminal blocks, we offer a number of value-added features designed to complement your manufacturing operation. Our marketing and engineering staff will evaluate your design or manufacturing parameters and develop a filter solution which provides increased filtering performance economically.

API Capabilities

- Custom assemblies with varying cable lengths and terminations
- Integrate a filter solution with other components to ensure a completely functional device
- Perform EMC evaluations on your equipment, recommending proper placement of EMI/RFI filtering components
- Custom high reliability assemblies

Filtered Headers

Replace the unfiltered connector on your PC board with API's low cost filtered header. This innovative new product allows you to meet EMC emissions and susceptibility standards with minimal or no board change.

Flat Conductor Cables

Flat conductor cables are often selected as an effective method of interconnection. API can save you time and money by installing conductor cables to your filter plates. Flat conductor cables are available in varying lengths, conductor counts and in several termination configurations.

Lead Stabilizer

API Technologies' Spectrum Control brand has developed a filter plate lead stabilizer bar to protect leads during installation and ensure proper alignment to PCB.

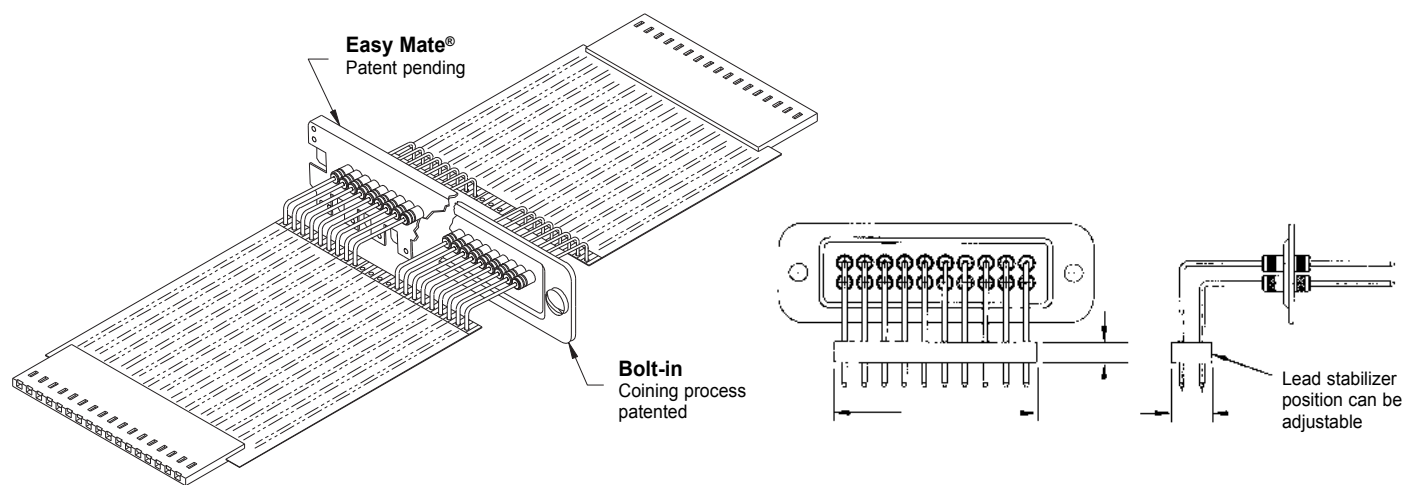



Custom Filtered Terminal Blocks

Terminal Block Design Inquiry Form

API Technologies' Spectrum Control brand can incorporate EMI filters into a variety of terminal block designs. We offer product variations from several terminal block manufacturers. In addition to developing a filtering solution, we will add custom wiring and terminations to meet your requirements. API offers:

- Unique package integration for customer specific needs
- Wide range of designs from numerous terminal block manufacturers
- Custom assemblies with varying cable lengths and terminations

Terminal Block Design Inquiry Form

General Information

| | |
|-----------------|-------------------------|
| Customer: _____ | Location: _____ |
| Address: _____ | |
| City: _____ | State: _____ Zip: _____ |
| Contact: _____ | Title: _____ |
| Phone: _____ | Fax: _____ |

Project Information

| | | |
|--|-----------------------|---------------------|
| Project name: _____ | Annual usage: _____ | Target price: _____ |
| Intended application: _____ | Quote quantity: _____ | |
| Function of circuit filter is used in: _____ | Target cost: _____ | |

| |
|--|
| <h3>Detailed Sketch and Comments Area</h3> |
|--|

EMI Filtered Connectors

from performance to board space, to cost, we offer many reasons and options for managing EMI @ the signal & power I/O

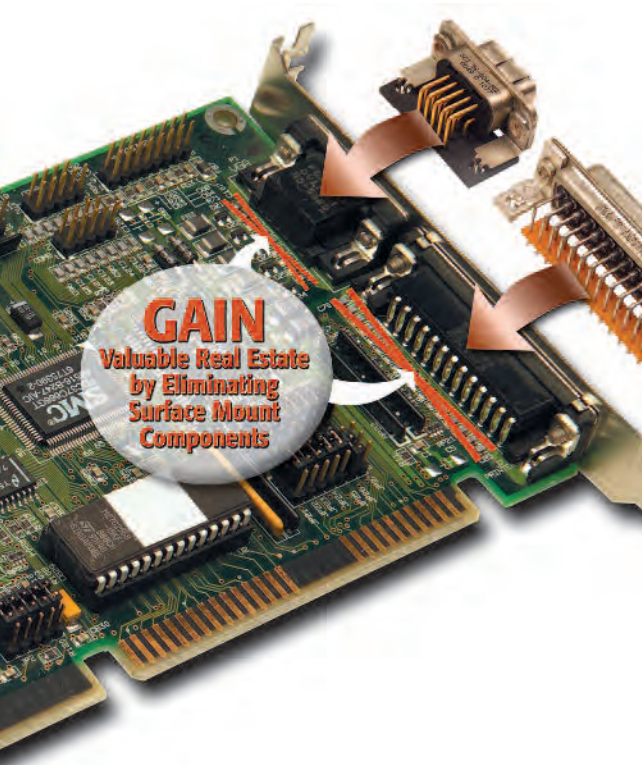

Series F Ferrite Filtered Connectors offer a low cost, space saving solution for high frequency interference... **FC3-FC7**

Series 500 Low-Profile Feed-Through Connectors deliver reliable EMI filtering in 90° PCB and straight PCB connectors... **FC8-FC11**

Series 600 Hi-Density Filtered Connectors meet the growing need for increased circuit densities in smaller packages... **FC12-FC13**

Series 700 High Performance Connectors feature feed-through capacitive and PI filters for the most effective filtering... **FC16-FC37**

Filtered Combo D-Sub Connectors use tubular capacitors for high insertion loss in signal, power and coaxial contacts... **FC38-FC48**

Micro D Series Connectors allow designers to incorporate EMI filtering into even smaller packages... **FC49-FC53**

Datacom Connectors including modular jack, miniature ribbon and mini-DIN protect critical datacom lines... **FC54-FC58**

USB Connectors incorporate EMI filtering and ESD protection into standard USB packages freeing up valuable board space... **FC59**

Hooded Strain Reliefs for shock protection from exposed wires and short circuits... **FC60**

Performance Specifications & Board/Panel Cutouts... **FC62-FC64**

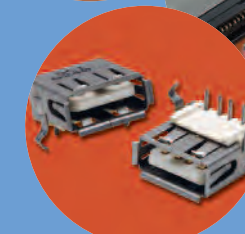
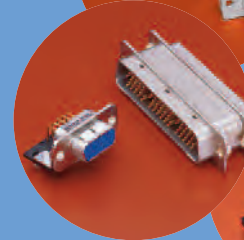

Advantages of a Filtered Connector

- **Low ground impedance** – Full ground plate and metallic shell provide minimal impedance and superior performance compared to on-board filter with high impedance
- **Eliminate re-radiation** – Filtered connector at interface leaves no path for bypassing the filter
- **Ground plane shielding** – API's filtered connector ground planes shield the box even at the connector port
- **Efficient space utilization** – Filters located in the connectors provide additional space on PCB board
- **Consistent performance** – Filtered connectors provide more consistent pin to pin performance
- **Fewer components** – Filtered connectors reduce component count creating cost savings
- **Reliability** – API tests 100% of filters, on-board filters are usually spot tested

Advantages of API Filtered Connectors

API Technologies' Spectrum Control brand offers the industry's most complete line of filtered D-subminiature connectors. Our connectors are available in shell sizes from 9 to 50, and come in many termination types, such as PC mount, wire wrap, solder cup and 90° PCB. In addition, API offers a wide range of filtering options, allowing you to find the right balance between performance and economy.

EMI filter options include our Pi filter configuration, which provides 45-60 dB per decade slope to insertion loss curve, our capacitive-only C filters that provide cost-effective EMI attenuation, ferrite filtered series F connectors (designed for filtering in situations that do not tolerate capacitive loading of circuit), as well as our series 500 connectors, with small .318" footprints.

The construction of our high performance Series 600 and 700 connectors features a one-piece zinc diecast shell, which is subsequently nickel-plated. Each filter is constructed with 360° grounding with ground plate, and our patented coaxial springs ensure ground continuity. And with API's advanced in-house ceramic tube design, you'll get a reliable, high performance filter from start to finish.

Advantages of an API Filtered Connector

- **Low ground impedance** – Full ground plate and metallic shell provide minimal impedance and superior performance compared to on-board filter with high impedance
- **Eliminate re-radiation** – Filtered connector at interface leaves no path for bypassing the filter
- **Ground plane shielding** – API filtered connector ground planes shield the box even at the connector port
- **Efficient space utilization** – Filters located in connector provides additional space on PCB board
- **Consistent performance** – Filtered connectors provide more consistent pin to pin performance
- **Fewer components** – Filtered connectors reduce component count creating cost savings
- **Reliability** – API tests 100% of filters, on-board filters are usually spot tested

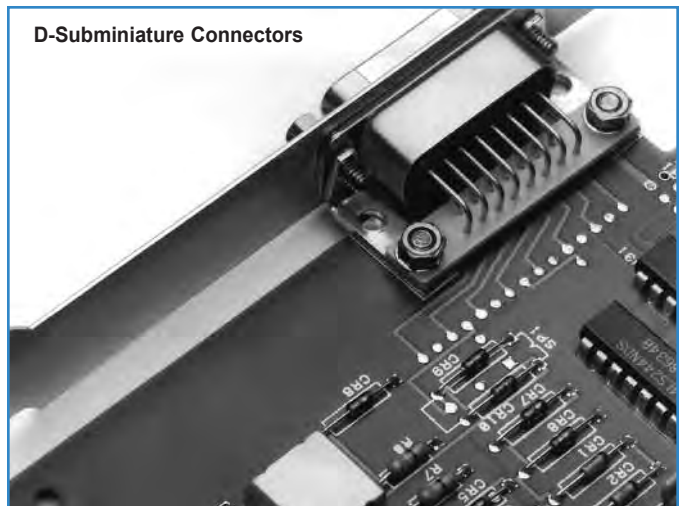

D-Subminiature Connectors

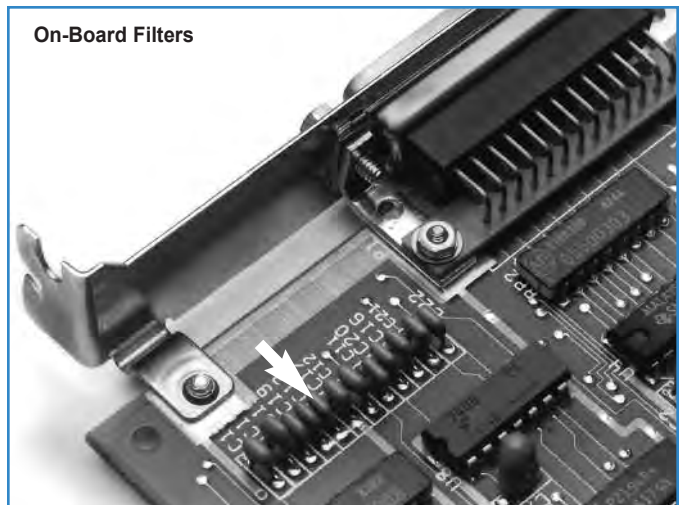

On-Board Filters

Series F Ferrite Filtered Connectors

The Series F filtered D-subminiature connectors incorporate a solid slab of ferrite material as the filtering element. This rugged one-piece design provides a compact connector that is a drop-in replacement for standard connectors. The ferrite material has been chosen for optimum filtering performance in the 10 to 300 MHz range.

Series F Applications

- Personal computers, microcomputer-applied products and peripheral/terminal equipment
- Eliminates common-mode noise along data lines in data communication terminals and digital equipment

Features

- Low cost, high performance ferrite filter
- No distortion of wave forms
- Replaces individual ferrite bead filters, saving cost and space
- Provides both pin to ground and pin to pin filtering
- Effective in helping meet requirements of FCC, VDE, EN55022 and Japan's VCCI
- Short, space saving .318" footprint
- Interchangeable with standard D-subminiature connectors
- Can be installed directly over PCB trace pattern with no shorting
- 4-40 UNC locking insert eliminates loose hardware
- Metal shielding front shell
- Gold plated contacts
- RoHS compliant versions available (replace 56- with 56F)

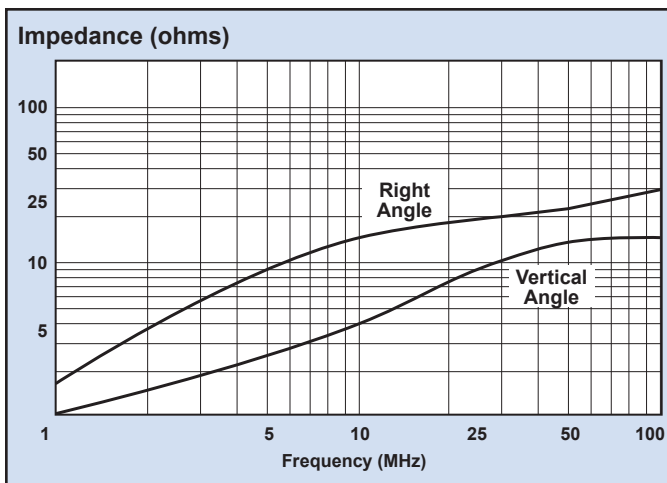

Mechanical Specifications

- Front Shell* Steel (Tin plated)
- Housing* UL 94V-0 Rated thermoplastic, black
- Contacts* Phosphor bronze (sockets) or brass (pins)
- Contact Plating* Gold Flash (<10µ in.) over nickel
- Operating Temperature* -40°C to +105°C

Electrical Specifications

| Frequency (MHz) | Impedance (Ohms) | |
|-----------------|------------------|----------|
| | Right Angle | Vertical |
| 1 | 2 | 1 |
| 10 | 15 | 6 |
| 30 | 20 | 10 |
| 50 | 23 | 12 |
| 100 | 27 | 15 |

- Frequency Range* 10 – 300 MHz
- Current Rating* 5 Amps
- Dielectric Withstand Voltage* . . 1000 VAC for one minute
- Insulation Resistance* 1000 megohms Min. @ 500VDC

Series F Ferrite Filtered Connectors

Pin Contact – Right Angle Mount



| Part Number | Description | Typ. Impedance (Ohms) | | Frequency Range | A +/- | B +/- | C +/- | D +/- | E +/- | F +/- | G +/- | H +/- | I +/- | J +/- |
|--------------|--------------|-----------------------|---------|-------------------|------------------|------------------|------------------|-----------------|------------------|------------------|-----------------|------------------|------------------|------------------|
| | | 30 MHz | 100 MHz | | 0.010 (0.25) | 0.005 (0.13) | 0.015 (0.38) | 0.010 (0.25) | 0.015 (0.38) | 0.005 (0.13) | 0.004 (0.10) | 0.005 (0.13) | 0.005 (0.13) | 0.005 (0.13) |
| € 56-402-001 | D-Sub 9 pin | 20 | 27 | 10 MHz to 300 MHz | 0.666 (16.92) | 0.984 (25.00) | 1.213 (30.81) | 0.318 (8.08) | 0.751 (19.10) | 0.324 (8.22) | 0.108 (2.74) | 0.984 (25.00) | 0.432 (10.98) | 0.606 (15.40) |
| € 56-412-001 | D-Sub 15 pin | | | | 0.994 (25.25) | 1.312 (33.32) | 1.541 (39.14) | 0.318 (8.08) | 0.751 (19.10) | 0.648 (16.46) | 0.108 (2.74) | 1.312 (33.32) | 0.756 (19.20) | 0.929 (23.60) |
| € 56-422-001 | D-Sub 25 pin | | | | 1.534 (38.96) | 1.852 (47.04) | 2.088 (53.04) | 0.318 (8.08) | 0.751 (19.10) | 1.196 (30.36) | 0.110 (2.76) | 1.852 (47.04) | 1.304 (31.12) | 1.476 (37.50) |

€ Also available through API's authorized European distributors/agents.

Dimensions in inches (mm)

Series F Ferrite Filtered Connectors

Socket Contact – Right Angle Mount

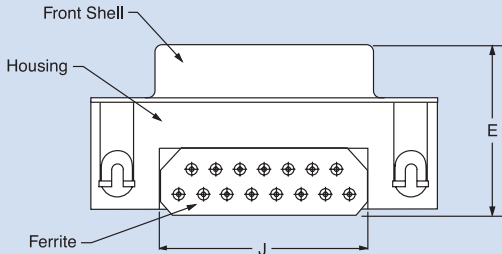

*High-Density

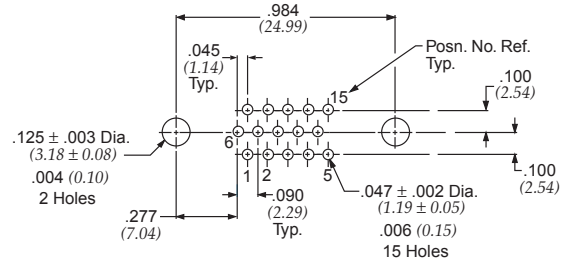
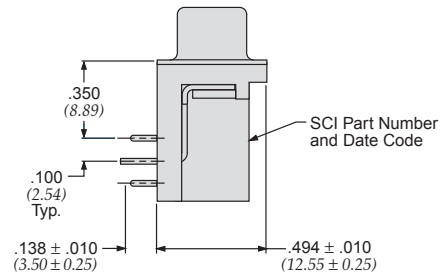

PC Board Mounting Dimensions



PC Board Mounting Dimensions

| Part Number | Description | Typ. Impedance (Ohms) | | Frequency Range | A +/- | B +/- | C +/- | D +/- | E +/- | F +/- | G +/- | H +/- | I +/- | J +/- |
|-----------------|----------------------|-----------------------|---------|-------------------|---------------------|------------------|------------------|-----------------|------------------|------------------|-----------------|------------------|------------------|------------------|
| | | 30 MHz | 100 MHz | | 0.010 | 0.005 | 0.015 | 0.010 | 0.015 | 0.005 | 0.004 | 0.005 | 0.005 | 0.005 |
| € 56-404-001 | D-Sub 9 socket | 20 | 27 | 10 MHz to 300 MHz | 0.643 (16.33) | 0.984 (25.00) | 1.213 (30.81) | 0.318 (8.08) | 0.755 (19.20) | 0.324 (8.22) | 0.108 (2.74) | 0.984 (25.00) | 0.432 (10.98) | 0.606 (15.40) |
| € 56-414-001 | D-Sub 15 socket | | | | 0.971 (24.66) | 1.312 (33.32) | 1.541 (39.14) | 0.318 (8.08) | 0.755 (19.20) | 0.648 (16.46) | 0.108 (2.74) | 1.312 (33.32) | 0.756 (19.20) | 0.929 (23.60) |
| € 56-424-001 | D-Sub 25 socket | | | | 1.511 (38.38) | 1.852 (47.04) | 2.088 (53.04) | 0.318 (8.08) | 0.755 (19.20) | 1.196 (30.36) | 0.110 (2.76) | 1.852 (47.04) | 1.304 (31.12) | 1.476 (37.50) |
| € 56-414-001-HD | Hi-Density 15 socket | 16 | 26 | | * See inset drawing | | | | | | | | | |

€ Also available through API's authorized European distributors/agents.

Dimensions in inches (mm)

Series F Ferrite Filtered Connectors

Pin Contact – Vertical Mount

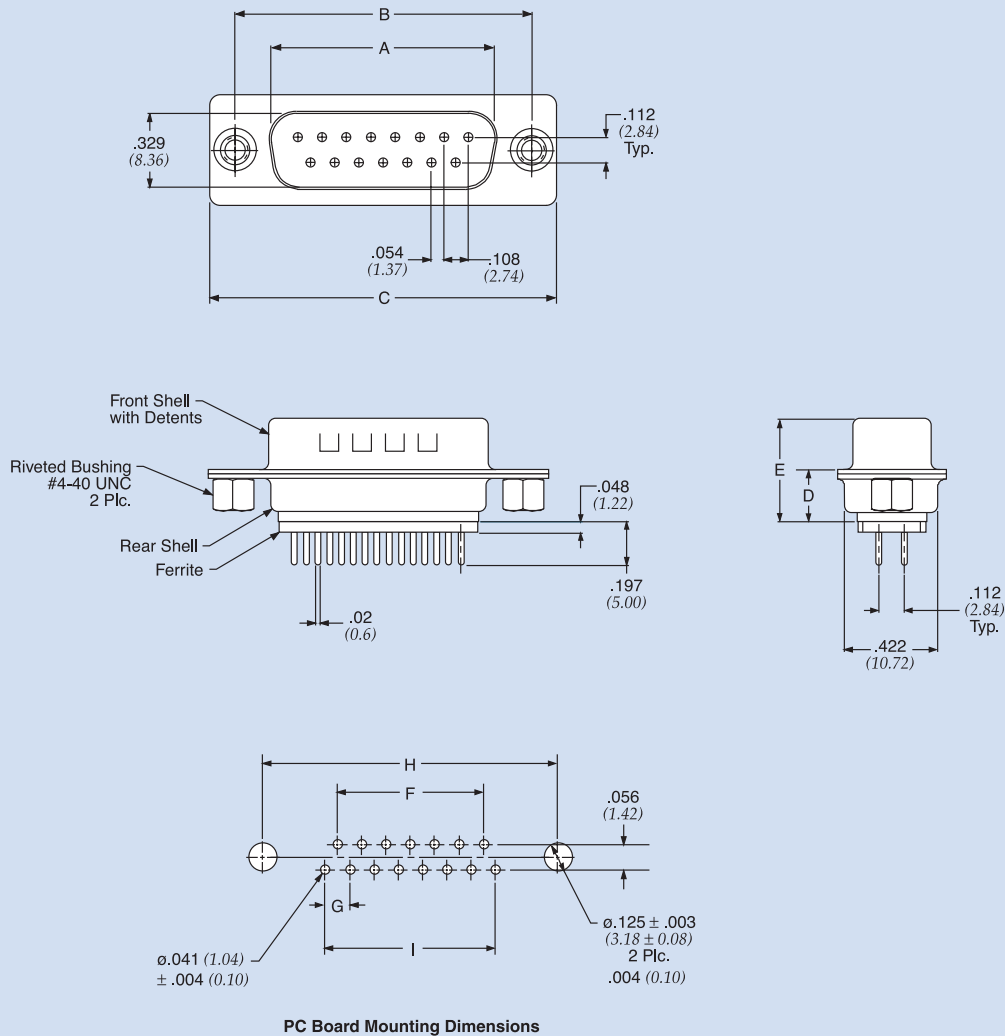

| Part Number | Description | Typ. Impedance (Ohms) | | Frequency Range | A +/- | B +/- | C +/- | D +/- | E +/- | F +/- | G +/- | H +/- | I +/- |
|-------------|--------------|-----------------------|---------|-------------------|------------------|------------------|------------------|-----------------|------------------|------------------|-----------------|------------------|------------------|
| | | 30 MHz | 100 MHz | | 0.010 (0.25) | 0.005 (0.13) | 0.015 (0.38) | 0.010 (0.25) | 0.015 (0.38) | 0.005 (0.13) | 0.004 (0.10) | 0.005 (0.13) | 0.005 (0.13) |
| 56-407-001 | D-Sub 9 pin | 10 | 15 | 10 MHz to 300 MHz | 0.666 (16.92) | 0.984 (25.00) | 1.213 (30.81) | 0.236 (5.99) | 0.468 (11.88) | 0.324 (8.22) | 0.108 (2.74) | 0.984 (25.00) | 0.432 (10.98) |
| 56-417-001 | D-Sub 15 pin | | | | .994 (25.25) | 1.312 (33.32) | 1.541 (39.14) | 0.236 (5.99) | 0.468 (11.88) | 0.648 (16.46) | 0.108 (2.74) | 1.312 (33.32) | 0.756 (19.20) |
| 56-427-001 | D-Sub 25 pin | | | | 1.534 (38.96) | 1.852 (47.04) | 2.088 (53.04) | 0.236 (5.99) | 0.468 (11.88) | 1.196 (30.36) | 0.110 (2.76) | 1.852 (47.04) | 1.304 (31.12) |

Dimensions in inches (mm)

Series F Ferrite Filtered Connectors

Socket Contact – Vertical Mount

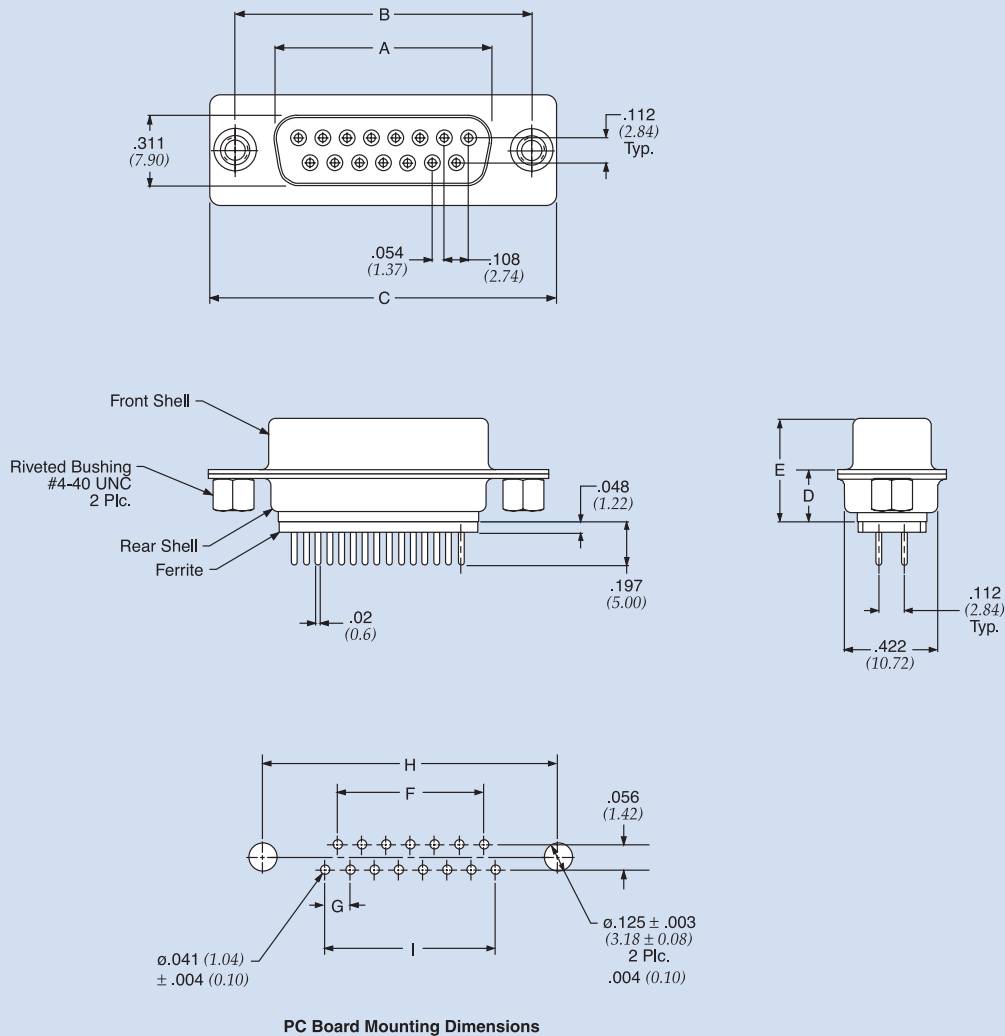

| Part Number | Description | Typ. Impedance (Ohms) | | Frequency Range | A +/- | B +/- | C +/- | D +/- | E +/- | F +/- | G +/- | H +/- | I +/- |
|-------------|-----------------|-----------------------|---------|-------------------|------------------|------------------|------------------|-----------------|------------------|------------------|-----------------|------------------|------------------|
| | | 30 MHz | 100 MHz | | 0.010 (0.25) | 0.005 (0.13) | 0.015 (0.38) | 0.010 (0.25) | 0.015 (0.38) | 0.005 (0.13) | 0.004 (0.10) | 0.005 (0.13) | 0.005 (0.13) |
| 56-403-001 | D-Sub 9 socket | 10 | 15 | 10 MHz to 300 MHz | 0.643 (16.33) | 0.984 (25.00) | 1.213 (30.81) | 0.236 (5.99) | 0.472 (11.98) | 0.324 (8.22) | 0.108 (2.74) | 0.984 (25.00) | 0.432 (10.98) |
| 56-413-001 | D-Sub 15 socket | | | | .971 (24.66) | 1.312 (33.32) | 1.541 (39.14) | 0.236 (5.99) | 0.472 (11.98) | 0.648 (16.46) | 0.108 (2.74) | 1.312 (33.32) | 0.756 (19.20) |
| 56-423-001 | D-Sub 25 socket | | | | 1.511 (38.38) | 1.852 (47.04) | 2.088 (53.04) | 0.236 (5.99) | 0.472 (11.98) | 1.196 (30.36) | 0.110 (2.76) | 1.852 (47.04) | 1.304 (31.12) |

Dimensions in inches (mm)

Series 500 Low Profile Filtered Connectors

API's Spectrum Control brand of Series 500 are cost effective, highly reliable EMI filtered D-subminiature connectors that feature a .318" footprint for 90 degree PCB connectors and a low profile housing for straight PCB connectors. Series 500 filtered D-sub are "drop-in" replacements for standard unfiltered D-sub connectors.

The ability of these connectors to achieve EMI filtering within the smaller footprint is the result of technical advances in ceramic capacitors. Series 500 connectors use tubular capacitors for high performance EMI filtering. Quality features for these connectors include board lock mounting, metal front shells and gold plated contacts.

Series 500 capacitive filtered D-sub connectors are an ideal solution to FCC/EC/VCCI emissions problems. These connectors are designed to protect equipment from external EMI noise and eliminate system glitches.

Series 500 Applications

- Personal computers
- Industrial process equipment
- Graphics workstations
- PBX telecommunications equipment
- Cellular base stations and medical electronics

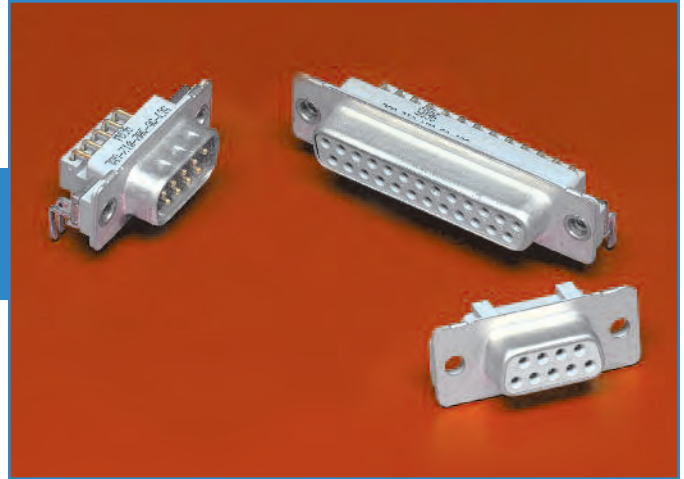

Features

- "Drop-in" replacements for unfiltered D-subminiatures
- Compact design, featuring .318" footprint
- Tubular feed-through capacitors provide filtering superior to on-board components
- Ground plane design provides EMI shielding
- Full interchangeability; based on MIL-C-24308
- Each connector position is tested 100% for critical electrical parameters to ensure consistent performance
- Insulators are UL recognized UL94-V0 flammability rated
- 9, 15 and 25 shell sizes
- Available with board lock feature and 4-40 mounting threads
- Selective filtering available
- UL/CSA approved
- Greater than 40 dB filtering up through 1 GHz without resonances
- Bi-directional control of EMI at the I/O ports

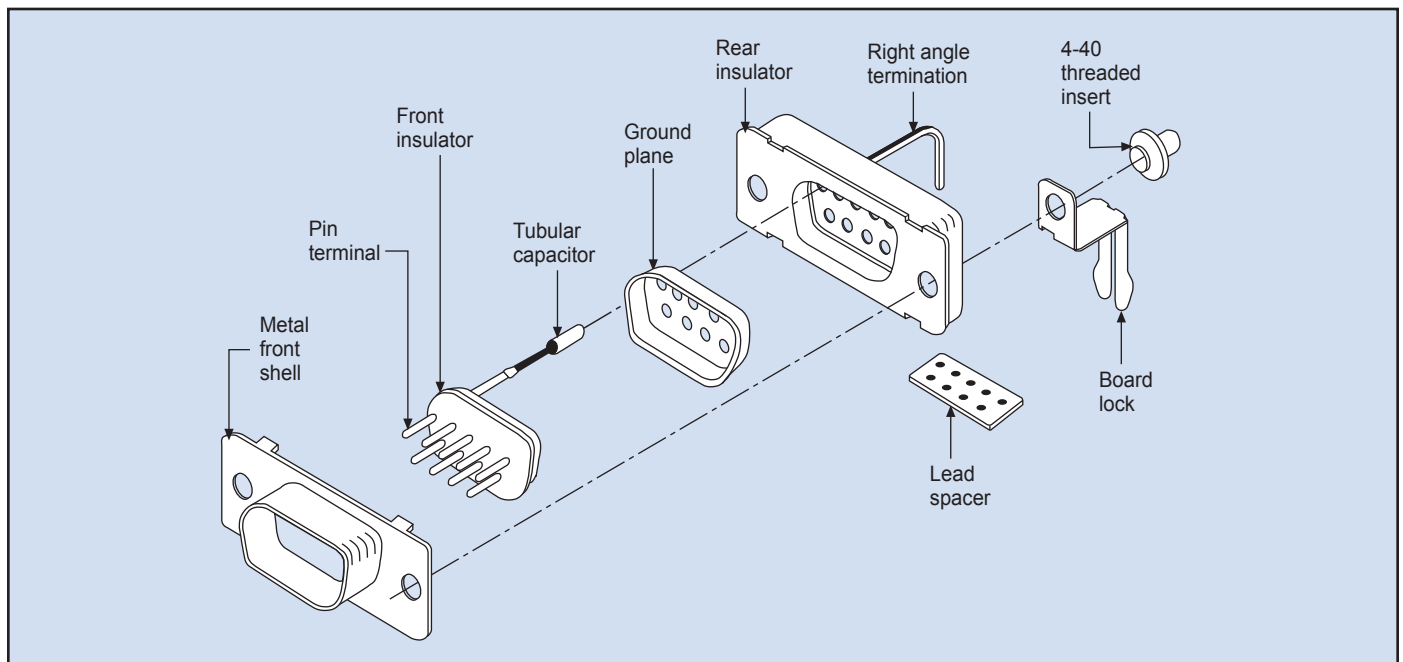

Series 500 Low Profile Filtered Connectors

Mechanical Specifications

- Shell Steel, tin plated
- Insulators Glass-filled polyester, flammability UL94V-O
- Pin Contacts Copper alloy CA725, 15 microinch (0.38 μm) gold plated* over nickel
- Socket Contacts Copper alloy CA725, 30 microinch (0.76 μm) gold plated* over nickel
- *Heavier gold plating available upon request.*
- Ground Plane Phosphor bronze, nickel plated
- Operating Temperature -40°C to +125°C
- Capacitors Proprietary barium titanate ceramic formulations

Other environmental tests such as shock, vibration, humidity, etc. are performed as detailed in our filtered connector performance specifications on page FC81.

Electrical Specifications

- Current Rating 5 Amps
- RF Current Rating 0.3 Amps
- Contact Resistance 10 milliohms maximum
- Capacitance 120, 440, 840, 1000, 1500 pF $\pm 30\%$
- Working Voltage 100 VDC
- Dielectric Withstanding Voltage 300 VDC
- Insulation Resistance 1 Gohm minimum
- UL Recognized Under category of communication circuit accessories, File #E149046

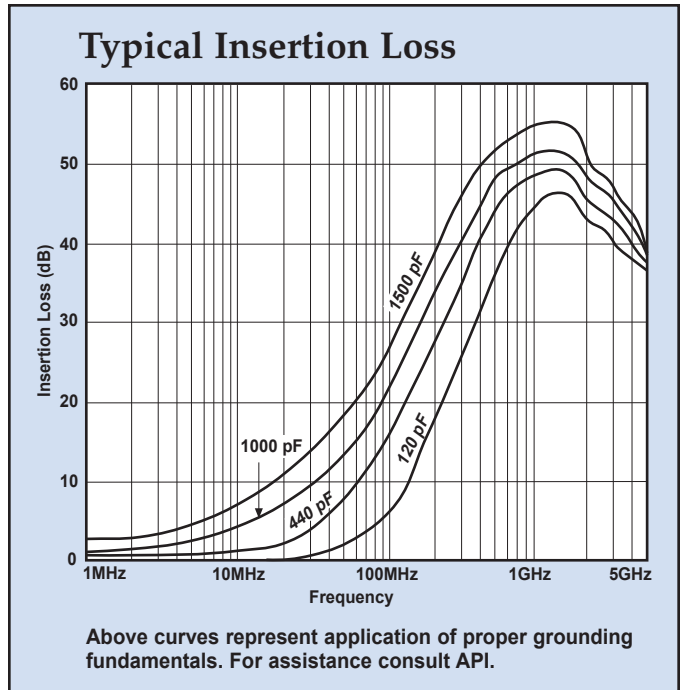
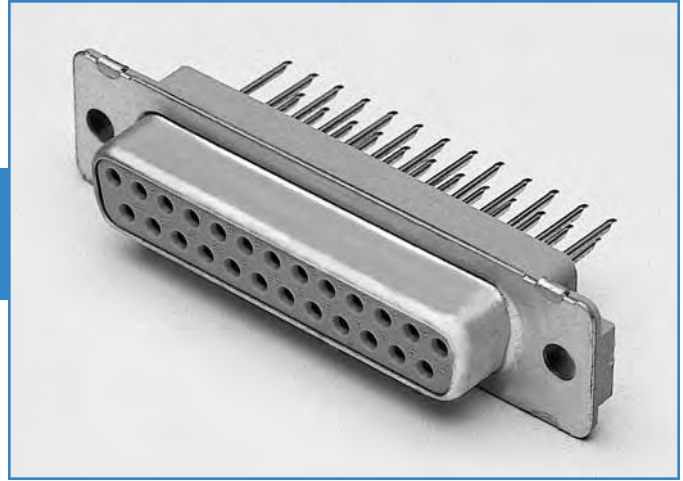

840 pF is typically within 2 dB of 1000 pF curve.

Filter Performance

| Cap. (pF) Value $\pm 30\%$ | 3 dB Cut-off Freq. (MHz) | Insertion Loss (dB) | | | | | |
|----------------------------|--------------------------|---------------------|---------|---------|-------|-------|-------|
| | | 20 MHz | 100 MHz | 500 MHz | 1 GHz | 2 GHz | 5 GHz |
| 120 | 40 | — | 4 | 21 | 26 | 26 | 20 |
| 440 | 11 | 3 | 15 | 27 | 33 | 32 | 25 |
| 840 | 6 | 6 | 19 | 32 | 38 | 37 | 25 |
| 1000 | 3 | 8 | 21 | 35 | 41 | 38 | 25 |
| 1500 | 2 | 10 | 25 | 40 | 47 | 42 | 25 |

Insertion loss measured per MIL-STD-220, no load, 50 ohm source and load. Above data represents guaranteed minimum.

Series 500 Low Profile Filtered Connectors

Pin Contact (*plug*) Straight PC Mount

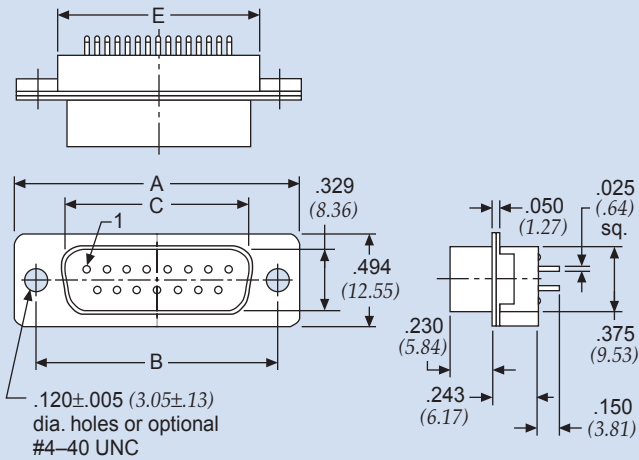

90° PC Mount

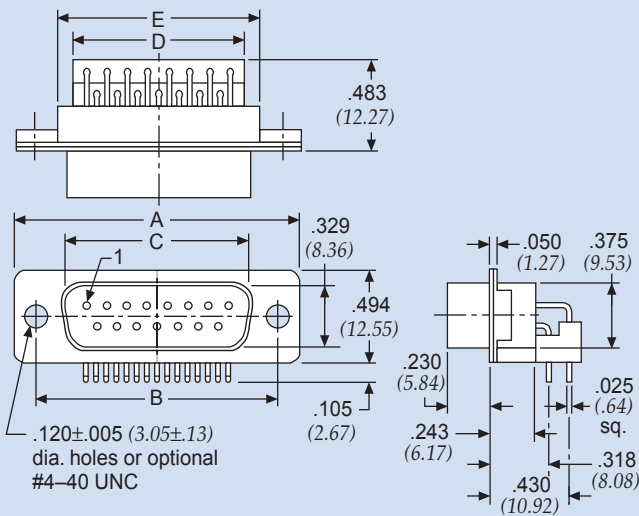

| Size | A | B | C | D | E |
|------|------------------|------------------|------------------|------------------|------------------|
| 9 | 1.213 (30.81) | 0.984 (24.99) | 0.666 (16.92) | 0.540 (13.72) | 0.748 (19.00) |
| 15 | 1.541 (39.14) | 1.312 (33.32) | 0.994 (25.25) | 0.867 (22.02) | 1.076 (27.33) |
| 25 | 2.088 (53.04) | 1.852 (47.04) | 1.534 (38.96) | 1.412 (35.86) | 1.616 (41.05) |

Standard Tolerance = ±.015 (0.38)

Dimensions in inches (mm)

Socket Contact (*receptacle*) Straight PC Mount

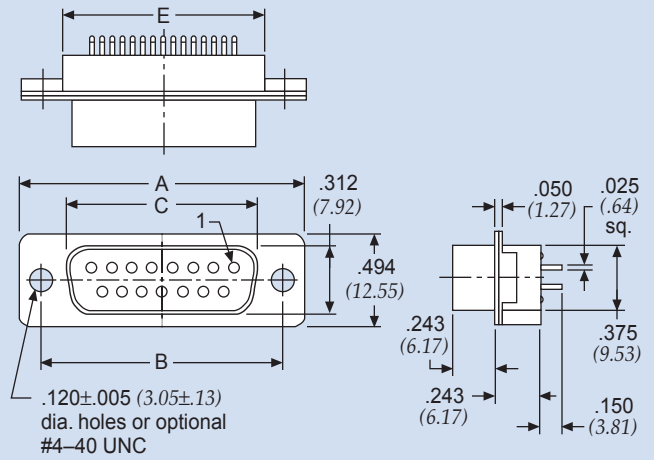

90° PC Mount

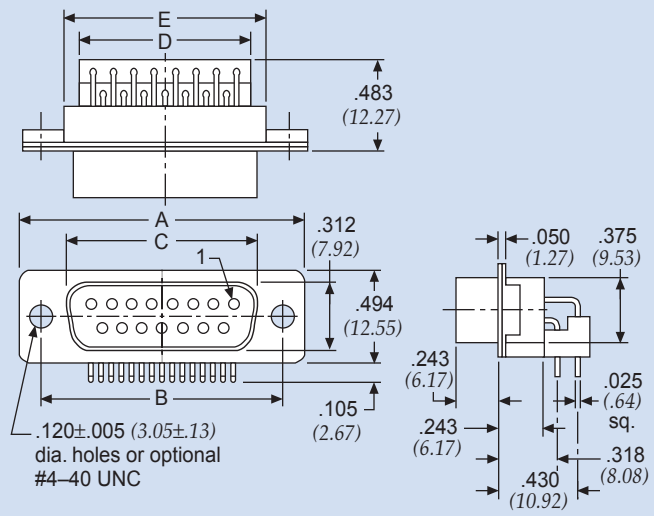

| Size | A | B | C | D | E |
|------|------------------|------------------|------------------|------------------|------------------|
| 9 | 1.213 (30.81) | 0.984 (24.99) | 0.642 (16.31) | 0.540 (13.72) | 0.748 (19.00) |
| 15 | 1.541 (39.14) | 1.312 (33.32) | 0.970 (24.64) | 0.867 (22.02) | 1.076 (27.33) |
| 25 | 2.088 (53.04) | 1.852 (47.04) | 1.510 (38.35) | 1.412 (35.86) | 1.616 (41.05) |

Standard Tolerance = ±.015 (0.38)

Dimensions in inches (mm)

Series 500 Low Profile Filtered Connectors

Ordering Information

Example: **56-524-013-GBL**

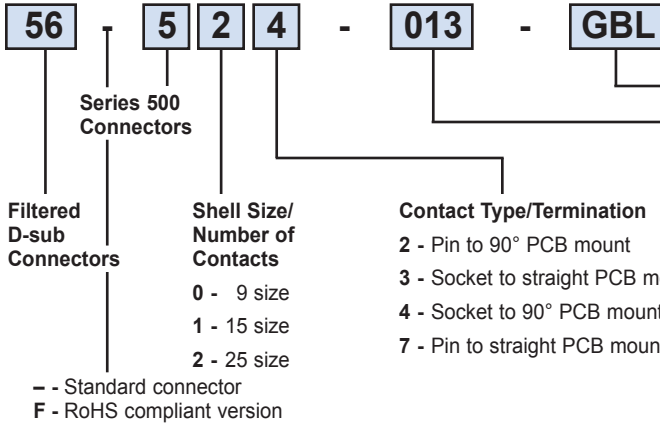

This part number represents a Series 500 filtered D-sub connector with 25 contacts, socket to 90° PCB mount configuration. The filter has a capacitance value of 1000 pF and the connector includes a grounded board lock.

For special needs or combinations of features, contact API engineering.

Capacitance Value
010 - 120 pF
011 - 440 pF
012 - 840 pF
013 - 1000 pF
014 - 1500 pF

Mounting or Hardware Options

TI - 4-40 threads on mounting flange (.120" (3.05mm) hole if not selected)
GBL - Grounded board lock, includes 4-40 threads (available only on 90° PCB)
GBLF - Grounded board lock and ferrite slab, provides the enhanced performance of an (LC) filter (available only on 90° PCB)

GBL Option

Features

- Snap-in retention to PC board, requires no hardware
- Ensures low ground impedance for superior filtering
- 4-40 threads on mounting flange eliminate loose hardware

Dimensions in inches (mm)

Board Layout

Typical Layout for .318" (8.08) Footprint

| Shell Size | A | B | C | D |
|------------|------------------|--|--|-----------------|
| 9 | .984 (24.99) | .436 = 4 x .109 (11.07 = 4 x 2.77) | .327 = 3 x .109 (8.31 = 3 x 2.77) | .492 (12.50) |
| 15 | 1.312 (33.32) | .763 = 7 x .109 (19.38 = 7 x 2.77) | .654 = 6 x .109 (16.61 = 6 x 2.77) | .656 (16.66) |
| 25 | 1.852 (47.04) | 1.308 = 12 x .109 (33.22 = 12 x 2.77) | 1.199 = 11 x .109 (30.45 = 11 x 2.77) | .926 (23.52) |

Dimensions in inches (mm)

Series 600 High-Density Filtered Connectors

The miniaturization of electronic systems and sub-systems is pushing designers to increase circuit densities within smaller packages. To address this growing need, API Technologies' Spectrum Control brand has developed a line of filtered High-Density D-subminiature connectors. This new line of connectors incorporates the high performance and reliable filtering of API's standard D-sub in the High-Density format.

Features

- Connectors designed to MIL-C-24308
- Capacitance values from 85 pF to 4000 pF
- Filter type feed-through C
- Selectively specify and filter each contact position
- Available in feed-through capacitive configurations

Mechanical Specifications:

Same as Series 700 connectors, page FC21.

Typical Insertion Loss

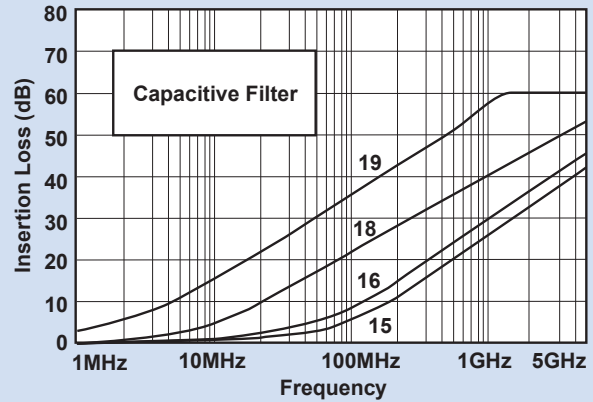

Insertion loss measured per MIL-STD-220, no load, 50 ohm source and load.

Electrical Specifications

Current Rating 3 Amps

RF Current Rating . . 0.3 Amps

Contact Resistance . . 15 milliohms maximum

UL Recognized Under category of communication circuit accessories, File #E149046

Electrical Specifications: High-Density Connectors

| Filter Designations | Filter Circuits | Capacitance | | 3 dB Cut-off Frequency Max. (MHz) | Dielectric With-standing Voltage | Working Voltage DC -55°C to +125°C | Minimum Insertion Loss - Decibels (dB) | | | | | | | | | |
|---------------------|-----------------|-------------|------|-----------------------------------|----------------------------------|------------------------------------|--|--------|--------|--------|---------|---------|---------|-------|-------|-------|
| | | Value | Tol. | | | | 5 MHz | 10 MHz | 20 MHz | 50 MHz | 100 MHz | 200 MHz | 500 MHz | 1 GHz | 2 GHz | 5 GHz |
| 15 | C | 85 pF | ±25% | 60 | 300V | 100V | — | — | — | — | 1 | 6 | 16 | 21 | 22 | 20 |
| 16 | | 180 pF | ±25% | 28 | 300V | 100V | — | — | — | 1 | 8 | 10 | 18 | 25 | 26 | 24 |
| 18 | | 1000 pF | ±25% | 5.1 | 300V | 100V | — | 3 | 8 | 14 | 20 | 25 | 32 | 35 | 41 | 39 |
| 19 | | 4000 pF | ±25% | 1.3 | 300V | 100V | 8 | 13 | 19 | 26 | 31 | 37 | 45 | 48 | 52 | 47 |

Filter designation "G" for grounded contacts, "I" for insulated (not filtered) contacts. Filter designation "O" for omitted contact and no hole in ground plane.

Above data represents guaranteed minimum.

Ordering Information

Example: **56-605-015-LI**

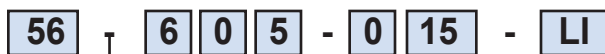

D-Sub Connector
Hi-Density

Shell Size**
0 = 15
1 = 26
2 = 44
3 = 62
4 = 78

Contact/Termination
1 - Pin to solder cup
2 - Pin to 90° PCB mount*
3 - Socket to PCB mount
4 - Socket to 90° PCB* mount
5 - Pin-socket adapter
7 - Pin to PCB mount

Special
0 = All positions same
9 = Special loading

** Some shell sizes require minimum order quantity. Consult API for details.

Filter Designation
15 - 85 pF FT
16 - 180 pF FT
18 - 1,000 pF FT
19 - 4,000 pF FT
20 - Insulated contact

Options
LI = 4-40 inserts
S = Solder dip tails
50G = μ gold
GBL = Grounding board lock

* Required on right angle parts

- Standard connector
F - RoHS compliant version

Note: VGA adapters also available. Consult factory

This part number represents a Series 600 Hi-Density filtered D-Sub connector with 15 contacts, pin-socket adapter configuration. The FT filters have a capacitance value of 85 pF and the connector includes 4-40 locking inserts.

Series 600 High-Density Filtered Connectors

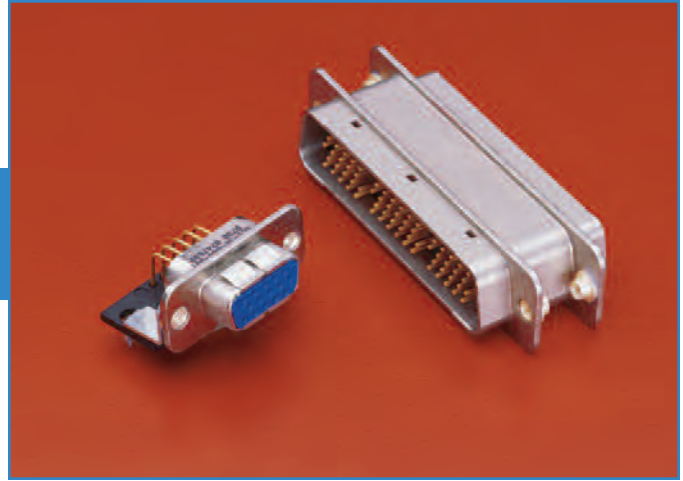

Pin/Socket Adapter

| Size | A | B | C | D | E | F | G |
|------|------------------|------------------|------------------|-----------------|-----------------|------------------|-----------------|
| 15 | 1.213 (30.81) | .984 (24.99) | .640 (16.26) | .304 (7.72) | .505 (12.83) | .666 (16.92) | .333 (8.46) |
| 26 | 1.541 (39.14) | 1.312 (33.32) | .968 (24.59) | .304 (7.72) | .505 (12.83) | .994 (25.25) | .333 (8.46) |
| 44 | 2.088 (53.04) | 1.852 (47.04) | 1.508 (38.30) | .304 (7.72) | .505 (12.83) | 1.534 (38.96) | .333 (8.46) |
| 62 | 2.729 (69.32) | 2.500 (63.50) | 2.156 (54.76) | .304 (7.72) | .505 (12.83) | 2.182 (55.42) | .333 (8.46) |
| 78 | 2.635 (66.93) | 2.406 (61.11) | 2.062 (52.37) | .416 (10.57) | .615 (15.62) | 2.079 (52.81) | .420 (11.18) |

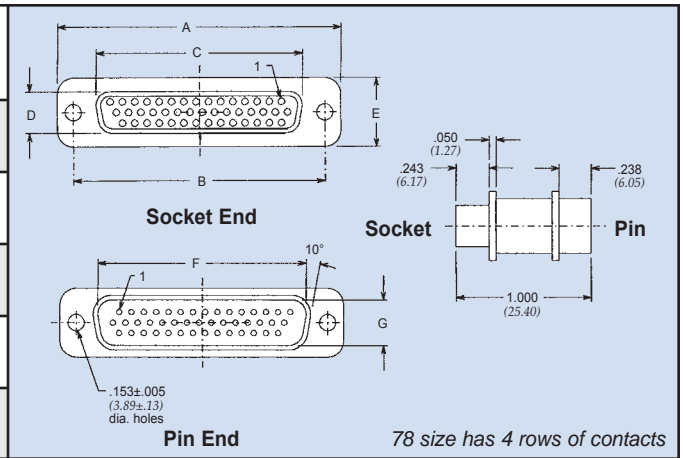

Pin or Socket to Solder Cup, PCB Mount and 90° PCB Mount

| Size | A | B | C | D | E | F | G |
|------|------------------|------------------|-----------------|------------------|-----------------|------------------|-----------------|
| 15 | 1.213 (30.81) | .984 (24.99) | .505 (12.83) | .666 (16.92) | .333 (8.46) | .757 (19.23) | .420 (10.67) |
| 26 | 1.541 (39.14) | 1.312 (33.32) | .505 (12.83) | .994 (25.25) | .333 (8.46) | 1.085 (27.56) | .420 (10.67) |
| 44 | 2.088 (53.04) | 1.852 (47.04) | .505 (12.83) | 1.534 (38.96) | .333 (8.46) | 1.625 (41.28) | .420 (10.67) |
| 62 | 2.729 (69.32) | 2.500 (63.50) | .505 (12.83) | 2.182 (55.42) | .333 (8.46) | 2.273 (57.73) | .420 (10.67) |
| 78 | 2.635 (66.93) | 2.406 (61.11) | .615 (15.62) | 2.079 (52.81) | .440 (11.18) | 2.170 (55.12) | .527 (13.39) |

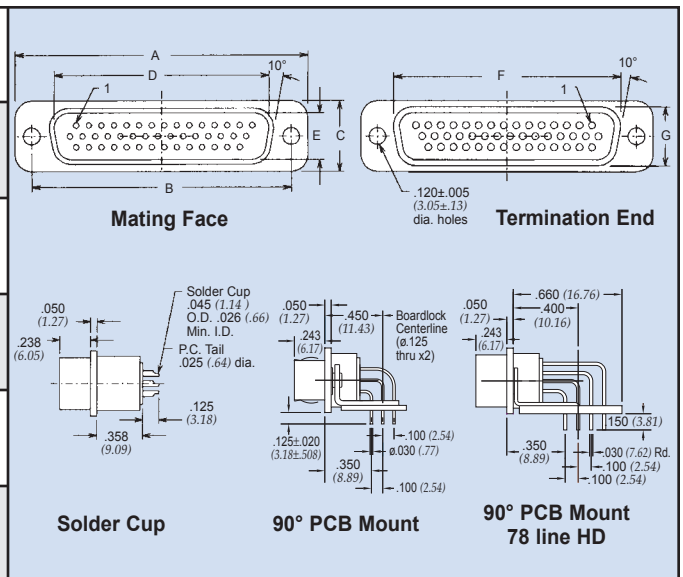

Dimensions in inches (mm)

High-Density Filtered Adapter for Telecommunications



Within the telecommunications industry, it has been standard practice to use an adapter (male/female) type of EMI filtered system connector as the interface between the switching system electronics and the premise wiring. These filtered adapters provide effective containment of EMI compared to either D-subminiature or 50-position “ribbon” contact type connectors.

The following several factors have mandated the development of a new generation of filtered adapters.

Special Requirements

- Higher density wiring
- The need for more contacts, usually a multiple of 16
- Higher reliability contact geometries
- Bellcore TR-NWT-001089 requirements
 - 1000 volts AC withstand for one minute
 - 2500 volts spike surge testing
- Improved flammable resistant plastic insulators

API’s Spectrum Control brand, in response to these unique requirements of the telecommunication industry, has developed a new high-density filtered adapter.

Features

- New ceramic technology and filter element construction to accept higher voltages
- Improved reliability compared to “ribbon” type connectors
- Integral ground plane and one-piece diecast housing for the highest level of EMI integrity
- More contacts/wires per square inch of panel space through high-density arrangements
- 64 contact positions standard, with 78 positions available by request in any filter combination

Mechanical Specifications

- Shell* Zinc or aluminum diecast, nickel plated 150 μ inches (3.81 μ m) min.
- Insulators* Thermoplastic, UL94V-0
- Contacts* One-piece, screw machined Copper alloy, contact area plated 50 μ inches (1.27 μ m) gold over 50 μ inches (1.27 μ m) nickel
- Ground Plane* Brass, solder plated
- Grounding Springs* Beryllium copper, tin plated per MIL-T-10727
- Operating Temperature* -55°C to +125°C
- Capacitor* High performance ceramic feed-through utilizing ultra low ESR design

Electrical Specifications

- Rated Voltage* 100 VDC
- Current Rating* 3 Amps
- DC Resistance* 15 milliohm max.
- Dielectric Withstanding Voltage* 1000 VRMS (FCC Part 68 test)
- Capacitance* 1000 pF, \pm 25%
- Voltage Surge* meets 2500 volts surge (10/1000) (See Wave form figure on next page)

High-Density Filtered Adapter for Telecommunications

Filter Performance

| Minimum Insertion Loss | |
|------------------------|-------|
| 20 MHz | 7 dB |
| 50 MHz | 14 dB |
| 100 MHz | 20 dB |
| 500 MHz | 32 dB |
| 1 GHz | 35 dB |
| 2 GHz | 41 dB |
| 5 GHz | 39 dB |

Insertion loss measured per MIL-STD-220, no load, 50 ohm source and load. Above data represents guaranteed minimum.

Part Number for Ordering: #56-645-002

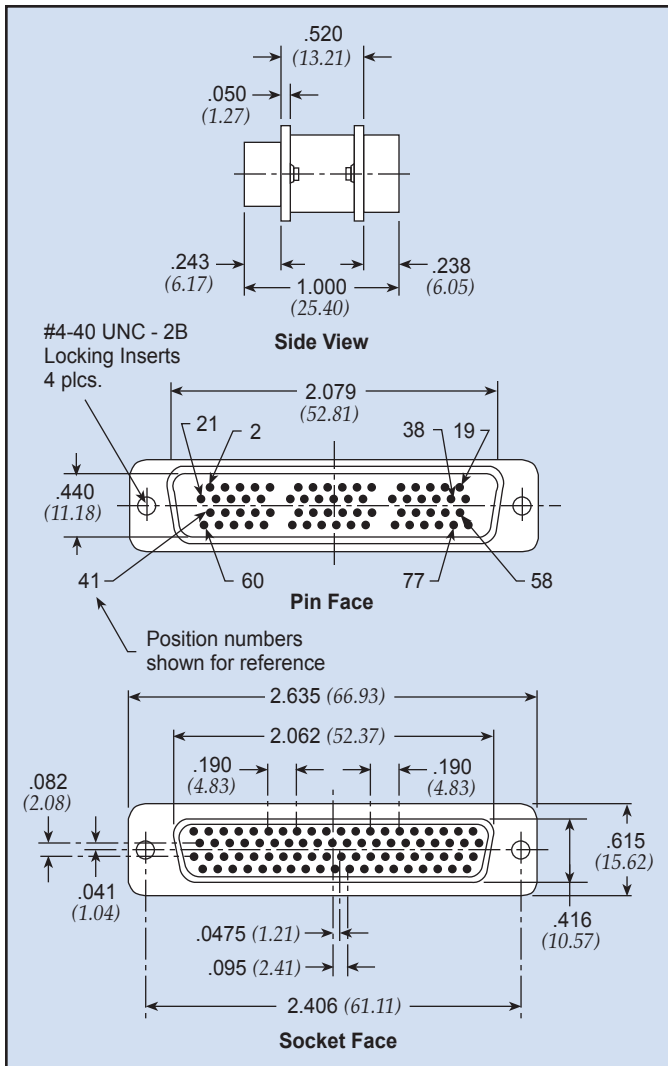

Dimensions in inches (mm)

Typical Insertion Loss

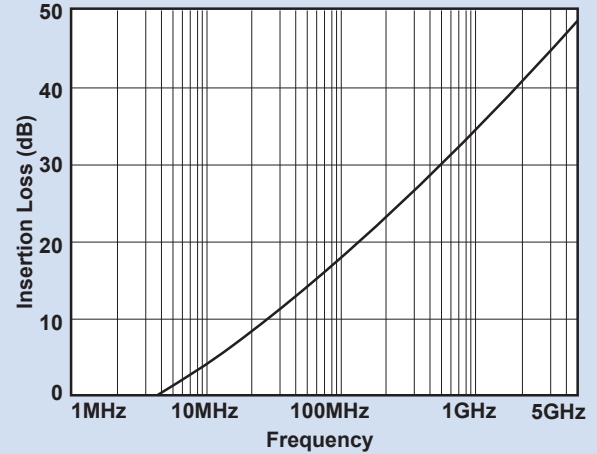

Above curves represent application of proper grounding fundamentals, for assistance consult with API.

Pulse Wave Form* (10 x 1000)

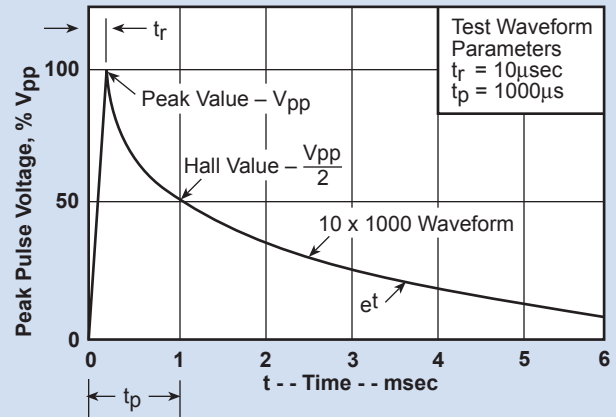

* Reference Bellcore TR-NWT-1089, $V_{pp} = 1000V$

Series 700 High Performance Filtered Connectors

Filter Selection

API's Spectrum Control brand of Series 700 connectors offer the highest performance filtering for all types of professional applications.

Features

- Available in 9, 15, 25, 37 and 50 shell sizes
- Variety of termination configurations including right angle and straight PCB for both pin and socket contact and as an adapter
- Capacitive and Pi type filters in a full range of capacitance values

The catalog data for this series is presented in order of shell size, and grouped by pin and socket contacts. Part numbers must be selected from the tables within the series section.

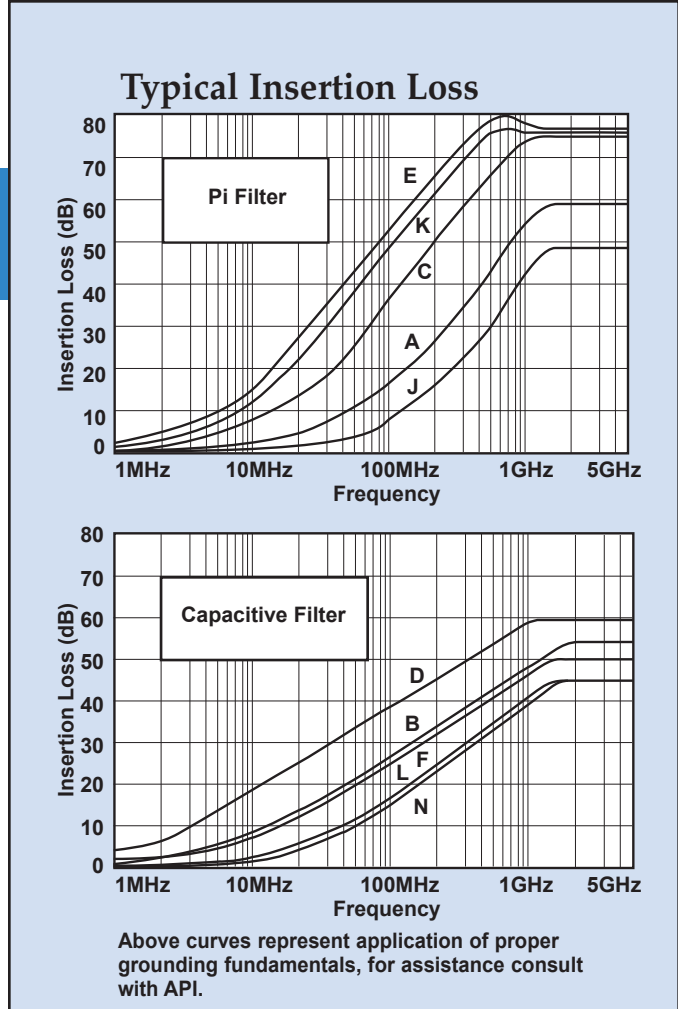

Insertion loss measured per MIL-STD-220, no load, 50ohm source and load.

Electrical Specifications: High Performance Connectors

| Filter Designations | Filter Circuits | Capacitance | | 3 dB Cut-off Frequency Max. (MHz) | Dielectric With-standing Voltage | Working Voltage DC -55°C to +125°C | Minimum Insertion Loss - Decibels (dB) | | | | | | | | | |
|---------------------|-----------------|-------------|----------|-----------------------------------|----------------------------------|------------------------------------|--|--------|--------|--------|---------|---------|---------|-------|-------|-------|
| | | Value | Tol. | | | | 5 MHz | 10 MHz | 20 MHz | 50 MHz | 100 MHz | 200 MHz | 500 MHz | 1 GHz | 2 GHz | 5 GHz |
| J | Pi | 100 pF | +100 -0% | 32 | 300V | 100V | — | — | — | 2 | 6 | 11 | 27 | 40 | 43 | 40 |
| A | | 310 pF | ±20% | 17 | 300V | 100V | — | — | 3 | 7 | 13 | 21 | 36 | 43 | 50 | 45 |
| C | | 1000 pF | +150 -0% | 3.2 | 300V | 100V | — | 5 | 9 | 19 | 30 | 43 | 62 | 70 | 68 | 63 |
| K | | 2500 pF | +100 -0% | 1.3 | 150V | 50V | 8 | 13 | 18 | 33 | 45 | 58 | 73 | 78 | 70 | 65 |
| E | | 4000 pF | +100 -0% | 0.8 | 150V | 50V | 8 | 13 | 20 | 35 | 48 | 61 | 76 | 80 | 70 | 65 |
| N | C | 375 pF | ±20% | 14 | 600V | 200V | — | — | 2 | 7 | 13 | 20 | 29 | 35 | 30 | 29 |
| L | | 500 pF | ±20% | 10.6 | 600V | 200V | — | — | 3 | 10 | 15 | 22 | 31 | 37 | 33 | 31 |
| F | | 830 pF | ±20% | 6.4 | 600V | 200V | — | 4 | 9 | 16 | 22 | 28 | 35 | 39 | 38 | 36 |
| B | | 1000 pF | +100 -0% | 3.2 | 600V | 200V | — | 5 | 10 | 17 | 23 | 30 | 37 | 43 | 44 | 42 |
| D | | 5000 pF | +100 -0% | 0.64 | 300V | 100V | 10 | 16 | 22 | 30 | 35 | 41 | 50 | 52 | 52 | 50 |

Filter designation "G" for grounded contacts, "I" for insulated (not filtered) contacts. Filter designation "O" for omitted contact and no hole in ground plane.

Above data represents guaranteed minimum.

Series 700 Specifications and Connector Ordering

Mechanical Specifications

Shell Zinc or aluminum diecast, nickel plated
 150 μ inches (3.81 μ m) min.

Insulators Glass-filled polyester,
 flammability UL94V-0

Pin Contacts Copper alloy, 15 μ inches
 (0.38 μ m) gold plated * over nickel

Socket Contacts Copper alloy, 30 μ inches
 (0.76 μ m) gold plated * over nickel

* Heavier gold plating available upon request.
 See pg. FC43: Connector Options

Terminations Gold flash for PCB mount and solder
 cups. Solder dipped also available.

Ground Plane Brass, solder plated

Grounding
 Springs Beryllium copper, tin plated per
 MIL-T-10727

Operating
 Temperature -55°C to +125°C

Capacitors Proprietary barium titanate
 ceramic formulations

Electrical Specifications

Current Rating 5 Amps

R.F. Current
 Rating 0.3 Amps

Contact
 Resistance 10 milliohms maximum

UL Recognized Under category of communication
 circuit accessories, File #E149046

Inductance on
 PI Filters ~ 860 nH between 100 kHz and 1 MHz

Solder cups accept up to a 20 gauge wire.

Note:
 For additional mechanical, electrical, and
 environmental specifications, refer to page FC79.

Ordering Your Connector

STEP 1: SELECTING THE FILTER

- Using the insert loss graphs on page FC20 determine which filters provide the required attenuation at the troublesome frequency, while not affecting the signal frequency by more than 3 to 6 dB.
- Choose the filter type, either feed-through capacitor or Pi. The Pi is generally considered better due to its superior high frequency performance and steeper curve. The feed-through capacitor is lower cost.
- Select capacitance value.
- Note the Spectrum letter designation for the filter chosen from the table on page FC20.

STEP 2: SELECTING THE CONNECTOR

- Turn to the appropriate size section. (9, 15, 25, 37, 50)
- Choose either pin contacts (plug) or socket contacts (receptacle).
- Choose the required termination type.
- From the table on the appropriate connector page, using the filter letter designation chosen in step 1 above, select the part number.

STEP 3: SPECIFYING OPTIONS

- Refer to page FC43 for special options including heavy gold plating, 4-40 mounting threads, grounding brackets, hardware, and others.
- Most options are available within the standard lead times.
- Some options require a part number suffix, while other combinations may require factory assistance for part number assignment. If a suffix is shown, add it to your selected part number. If more than one option is needed, consult with factory for part number assignment.

9 Series 700
Shell Size Pin Contact



Printed Circuit Board Mount

| Spectrum Part Number | EMI Filter | |
|----------------------|----------------------|------------|
| | Filter Designation** | Cap. Value |
| 56-701-001 | A | 310 pF Pi |
| 56-701-002 | B | 1000 pF C |
| 56-701-003 | C | 1000 pF Pi |
| 56-701-004 | D | 5000 pF C |
| 56-701-005 | E | 4000 pF Pi |
| 56-701-028 | F | 830 pF C |
| 56-701-029 | J | 100 pF Pi |
| 56-701-030 | K | 2500 pF Pi |
| 56-701-047 | N | 375 pF C |
| 56-701-086 | L | 500 pF C |

Mating Face
 .666 (16.92) x 1.213 (30.81) x .494 (12.55)
 .984 (24.99) x .329 (8.36)

Termination Face
 .120 ± .005 DIA. HOLES (3.05 ± 0.13 DIA. HOLES)
 .757 (19.23) x .420 (10.67)

Side View
 .050 (1.27) x .238 (6.05) x .150 (3.81) ± .025 SQ. (.64 SQ.)
 .408 (10.36) ± .020 (51 ± .13)

Printed Circuit Board Right Angle Mount

| Spectrum Part Number | EMI Filter | |
|----------------------|----------------------|------------|
| | Filter Designation** | Cap. Value |
| * 56-702-001 | A | 310 pF Pi |
| 56-702-002 | B | 1000 pF C |
| * 56-702-003 | C | 1000 pF Pi |
| 56-702-004 | D | 5000 pF C |
| * 56-702-005 | E | 4000 pF Pi |
| 56-702-007 | F | 830 pF C |
| 56-702-008 | J | 100 pF Pi |
| 56-702-009 | K | 2500 pF Pi |
| 56-702-013 | N | 375 pF C |
| * 56-702-033 | L | 500 pF C |

Mating Face
 .666 (16.92) x 1.213 (30.81) x .494 (12.55)
 .984 (24.99) x .329 (8.36)

Termination Face
 .120 ± .005 DIA. HOLES (3.05 ± 0.13 DIA. HOLES)
 .757 (19.23) x .420 (10.67)

Bottom View
 .125 ± .005 DIA. HOLES (3.18 ± 0.13 DIA. HOLES)
 .12R (3.05R) x .618 (15.70) x .540 (13.72) ± .025 SQ. (.64 SQ.)
 .290 (7.37) x .275 (6.99) x .740 (18.80) ± .105 (2.67) ± .590 (14.99) ± .702 (17.83)

Side View
 .025 SQ. (.64 SQ.)

* May be available from distributor stock.
 ** See page FC20 for filter performance.
 Standard Tolerance = ±.005 except where noted, ∅ = ±.015

Dimensions in inches (mm)

9 Series 700 Shell Size Pin Contact



Solderless Wire Wrap

| Spectrum Part Number <i>Select one</i> | EMI Filter | | | | |
|---|------------|-----------|-----------|--------------------|------------|
| | L .500 | L .375 | L .250 | Filter Desig.** | Cap. Value |
| 56-701 -006 -022 -017 | | | | A | 310 pF Pi |
| 56-701 -007 -023 -018 | | | | B | 1000 pF C |
| 56-701 -008 -024 -019 | | | | C | 1000 pF Pi |
| 56-701 -009 -025 -020 | | | | D | 5000 pF C |
| 56-701 -010 -026 -021 | | | | E | 4000 pF Pi |
| 56-701 -037 -034 -031 | | | | F | 830 pF C |
| 56-701 -038 -035 -032 | | | | J | 100 pF Pi |
| 56-701 -039 -036 -033 | | | | K | 2500 pF Pi |
| 56-701 -050 -049 -048 | | | | N | 375 pF C |

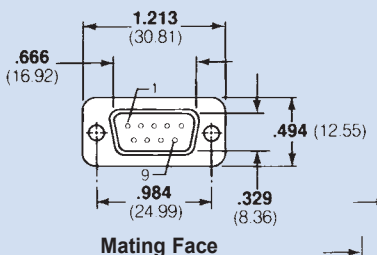
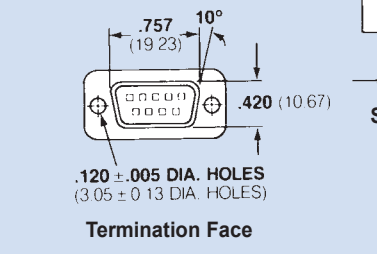
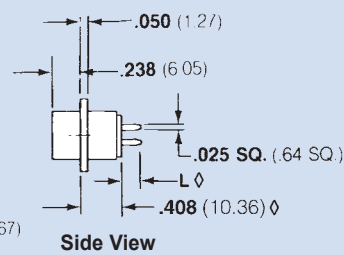
Solder Cup Termination

| Spectrum Part Number | EMI Filter | |
|----------------------|----------------------|------------|
| | Filter Designation** | Cap. Value |
| * 56-701-011 | A | 310 pF Pi |
| * 56-701-012 | B | 1000 pF C |
| * 56-701-013 | C | 1000 pF Pi |
| * 56-701-014 | D | 5000 pF C |
| * 56-701-015 | E | 4000 pF Pi |
| * 56-701-040 | F | 830 pF C |
| 56-701-041 | J | 100 pF Pi |
| 56-701-042 | K | 2500 pF Pi |
| 56-701-081 | N | 375 pF C |
| 56-701-087 | L | 500 pF C |

* May be available from distributor stock.

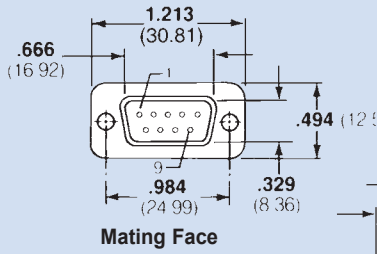
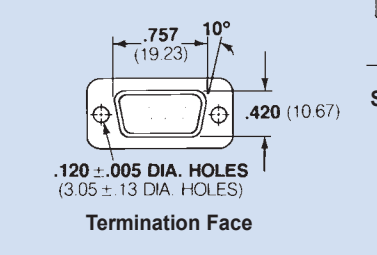
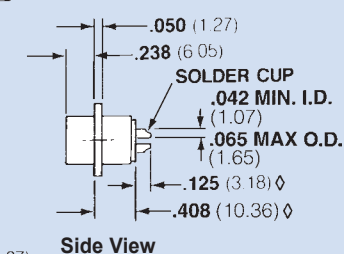
** See page FC20 for filter performance.

Standard Tolerance = ±.005 except where noted, ∅ = ±.015

Dimensions in inches (mm)

9 Series 700 Socket Contact

Shell Size

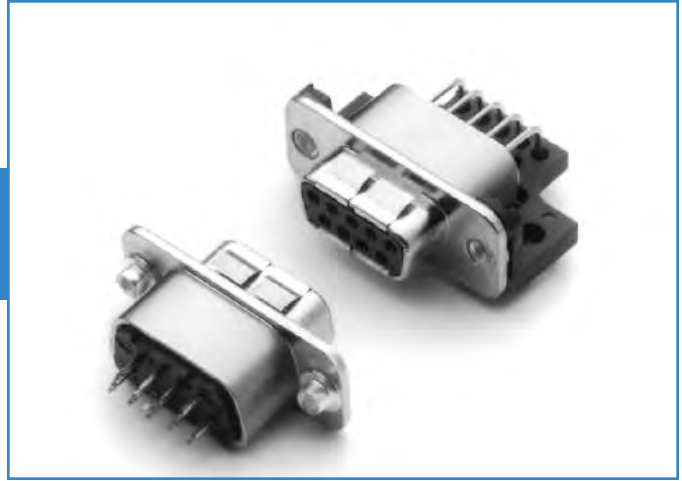

Printed Circuit Board Mount

| Spectrum Part Number | EMI Filter | |
|----------------------|----------------------|------------|
| | Filter Designation** | Cap. Value |
| 56-703-001 | A | 310 pF Pi |
| 56-703-002 | B | 1000 pF C |
| 56-703-003 | C | 1000 pF Pi |
| 56-703-004 | D | 5000 pF C |
| 56-703-005 | E | 4000 pF Pi |
| 56-703-022 | F | 830 pF C |
| 56-703-023 | J | 100 pF Pi |
| 56-703-024 | K | 2500 pF Pi |
| 56-703-036 | N | 375 pF C |
| 56-703-047 | L | 500 pF C |

Mating Face

Side View

Termination Face

Printed Circuit Board Right Angle Mount

| Spectrum Part Number | EMI Filter | |
|----------------------|----------------------|------------|
| | Filter Designation** | Cap. Value |
| 56-704-001 | A | 310 pF Pi |
| 56-704-002 | B | 1000 pF C |
| * 56-704-003 | C | 1000 pF Pi |
| 56-704-004 | D | 5000 pF C |
| * 56-704-005 | E | 4000 pF Pi |
| 56-704-007 | F | 830 pF C |
| 56-704-008 | J | 100 pF Pi |
| 56-704-009 | K | 2500 pF Pi |
| 56-704-018 | N | 375 pF C |
| 56-704-035 | L | 500 pF C |

Mating Face

Termination Face

Side View

Bottom View

* May be available from distributor stock.

** See page FC20 for filter performance.

Standard Tolerance = ±.005 except where noted, ∅ = ±.015

Dimensions in inches (mm)

9 Series 700 Shell Size Socket Contact & Pin/Socket Adapter



Solderless Wire Wrap

| Spectrum Part Number | EMI Filter | | | Filter Desig.** | Cap. Value |
|----------------------|------------|-----------|-----------|-----------------|------------|
| | Select one | | | | |
| | L .500 | L .375 | L .250 | | |
| 56-703 | -006 | -016 | -011 | A | 310 pF Pi |
| 56-703 | -007 | -017 | -012 | B | 1000 pF C |
| 56-703 | -008 | -018 | -013 | C | 1000 pF Pi |
| 56-703 | -009 | -019 | -014 | D | 5000 pF C |
| * 56-703 | -010 | -020 | * -015 | E | 4000 pF Pi |
| 56-703 | -031 | -028 | -025 | F | 830 pF C |
| 56-703 | -032 | -029 | -026 | J | 100 pF Pi |
| 56-703 | -033 | -030 | -027 | K | 2500 pF Pi |
| 56-703 | -039 | -038 | -037 | N | 375 pF C |

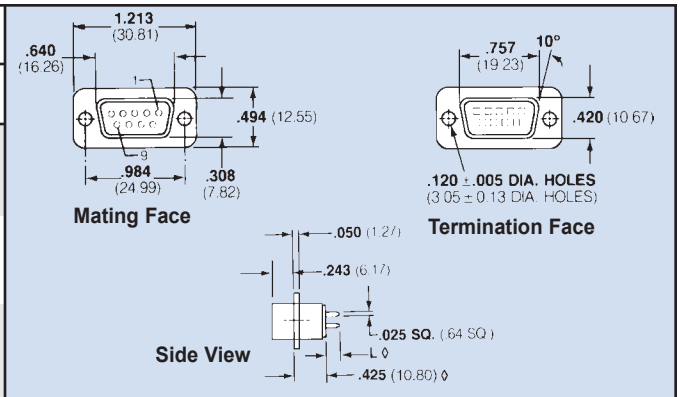

Solder Cup Termination

| Spectrum Part Number | EMI Filter | |
|----------------------|----------------------|------------|
| | Filter Designation** | Cap. Value |
| * 56-706-001 | A | 310 pF Pi |
| 56-706-002 | B | 1000 pF C |
| * 56-706-003 | C | 1000 pF Pi |
| 56-706-004 | D | 5000 pF C |
| * 56-706-005 | E | 4000 pF Pi |
| 56-706-006 | F | 830 pF C |
| 56-706-007 | J | 100 pF Pi |
| * 56-706-008 | K | 2500 pF Pi |
| 56-706-009 | N | 375 pF C |
| 56-706-017 | L | 500 pF C |

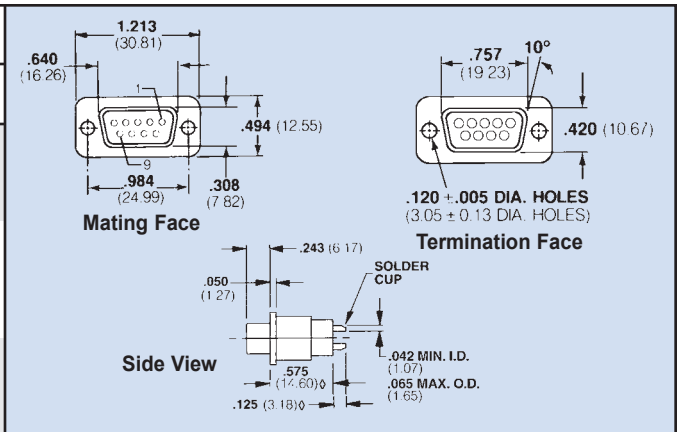

Pin/Socket Adapter

| Spectrum Part Number | EMI Filter | |
|----------------------|----------------------|------------|
| | Filter Designation** | Cap. Value |
| * 56-705-001 | A | 310 pF Pi |
| 56-705-002 | B | 1000 pF C |
| * 56-705-003 € | C | 1000 pF Pi |
| 56-705-004 | D | 5000 pF C |
| * 56-705-005 € | E | 4000 pF Pi |
| * 56-705-008 | F | 830 pF C |
| 56-705-009 | J | 100 pF Pi |
| 56-705-010 | K | 2500 pF Pi |
| 56-705-026 | N | 375 pF C |
| 56-705-049 | L | 500 pF C |

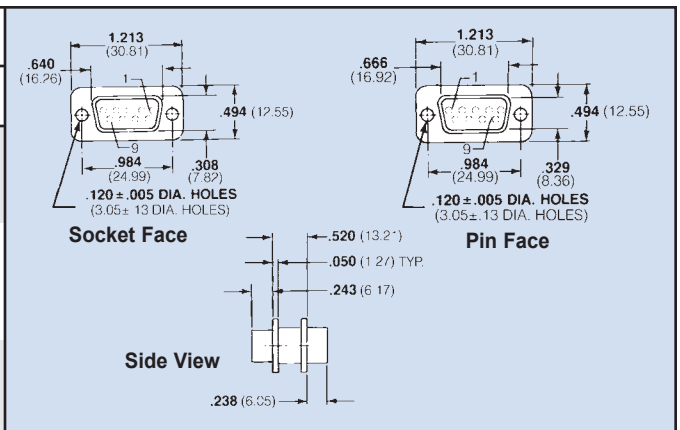

€ Also available through API's authorized European distributors/agents.

* May be available from distributor stock.

** See page FC20 for filter performance.

Standard Tolerance = ±.005 except where noted, φ = ±.015

API TECHNOLOGIES • 8061 Avonia Rd. • Fairview, PA 16415 • Ph: 814-474-1571 • Fax: 814-474-3110 • eis.apitech.com

API TECHNOLOGIES' SPECTRUM CONTROL GmbH • Hansastrasse 6 • 91126 Schwabach, Germany • Phone: (49)-9122-795-0 • Fax: (49)-9122-795-58

Dimensions in inches (mm)

15 Series 700 Shell Size Pin Contact



Printed Circuit Board Mount

| Spectrum Part Number | EMI Filter | |
|----------------------|----------------------|------------|
| | Filter Designation** | Cap. Value |
| 56-711-001 | A | 310 pF Pi |
| 56-711-002 | B | 1000 pF C |
| 56-711-003 | C | 1000 pF Pi |
| 56-711-004 | D | 5000 pF C |
| 56-711-005 | E | 4000 pF Pi |
| 56-711-028 | F | 830 pF C |
| 56-711-029 | J | 100 pF Pi |
| 56-711-030 | K | 2500 pF Pi |
| 56-711-048 | N | 375 pF C |
| 56-711-088 | L | 500 pF C |

Printed Circuit Board Right Angle Mount

| Spectrum Part Number | EMI Filter | |
|----------------------|----------------------|------------|
| | Filter Designation** | Cap. Value |
| * 56-712-001 | A | 310 pF Pi |
| 56-712-002 | B | 1000 pF C |
| * 56-712-003 | C | 1000 pF Pi |
| 56-712-004 | D | 5000 pF C |
| * 56-712-005 | E | 4000 pF Pi |
| * 56-712-007 | F | 830 pF C |
| 56-712-008 | J | 100 pF Pi |
| 56-712-009 | K | 2500 pF Pi |
| 56-712-017 | N | 375 pF C |
| 56-712-039 | L | 500 pF C |

* May be available from distributor stock.

** See page FC20 for filter performance.

Standard Tolerance = $\pm .005$ except where noted, $\diamond = \pm .015$

Dimensions in inches (mm)

15 Series 700 Shell Size Pin Contact



Solderless Wire Wrap

| Spectrum Part Number <i>Select one</i> | EMI Filter | | | | |
|---|------------|-----------|-----------|--------------------|------------|
| | L .500 | L .375 | L .250 | Filter Desig.** | Cap. Value |
| 56-711 -006 -023 -018 | | | | A | 310 pF Pi |
| 56-711 -007 -024 -019 | | | | B | 1000 pF C |
| 56-711 -008 -025 -020 | | | | C | 1000 pF Pi |
| 56-711 -009 -026 -021 | | | | D | 5000 pF C |
| 56-711 -010 -027 -022 | | | | E | 4000 pF Pi |
| 56-711 -037 -034 -031 | | | | F | 830 pF C |
| 56-711 -038 -035 -032 | | | | J | 100 pF Pi |
| 56-711 -039 -036 -033 | | | | K | 2500 pF Pi |
| 56-711 -051 -050 -049 | | | | N | 375 pF C |

Solder Cup Termination

| Spectrum Part Number | EMI Filter | |
|----------------------|----------------------|------------|
| | Filter Designation** | Cap. Value |
| * 56-711-011 | A | 310 pF Pi |
| 56-711-012 | B | 1000 pF C |
| * 56-711-013 | C | 1000 pF Pi |
| 56-711-014 | D | 5000 pF C |
| * 56-711-015 | E | 4000 pF Pi |
| * 56-711-040 | F | 830 pF C |
| 56-711-041 | J | 100 pF Pi |
| 56-711-042 | K | 2500 pF Pi |
| 56-711-085 | N | 375 pF C |
| 56-711-086 | L | 500 pF C |

* May be available from distributor stock.
 ** See page FC20 for filter performance.
 Standard Tolerance = ±.005 except where noted, ∅ = ±.015

Dimensions in inches (mm)

15 Series 700 Shell Size Socket Contact



Printed Circuit Board Mount

| Spectrum Part Number | EMI Filter | |
|----------------------|----------------------|------------|
| | Filter Designation** | Cap. Value |
| 56-713-001 | A | 310 pF Pi |
| 56-713-002 | B | 1000 pF C |
| 56-713-003 | C | 1000 pF Pi |
| 56-713-004 | D | 5000 pF C |
| 56-713-005 | E | 4000 pF Pi |
| 56-713-021 | F | 830 pF C |
| 56-713-022 | J | 100 pF Pi |
| 56-713-023 | K | 2500 pF Pi |
| 56-713-037 | N | 375 pF C |
| 56-713-045 | L | 500 pF C |

Printed Circuit Board Right Angle Mount

| Spectrum Part Number | EMI Filter | |
|----------------------|----------------------|------------|
| | Filter Designation** | Cap. Value |
| * 56-714-001 | A | 310 pF Pi |
| 56-714-002 | B | 1000 pF C |
| * 56-714-003 | C | 1000 pF Pi |
| 56-714-004 | D | 5000 pF C |
| * 56-714-005 | E | 4000 pF Pi |
| * 56-714-006 | F | 830 pF C |
| 56-714-007 | J | 100 pF Pi |
| 56-714-008 | K | 2500 pF Pi |
| 56-714-017 | N | 375 pF C |
| 56-714-031 | L | 500 pF C |

* May be available from distributor stock.

** See page FC20 for filter performance.

Standard Tolerance = ± 0.005 except where noted, $\diamond = \pm 0.015$

Dimensions in inches (mm)

15 Series 700 Shell Size Socket Contact & Pin/Socket Adapter



Solderless Wire Wrap

| Spectrum Part Number <i>Select one</i> | EMI Filter | | | |
|---|------------|-----------|-----------|------------------------------|
| | L .500 | L .375 | L .250 | Filter Desig.** / Cap. Value |
| 56-713-006 | -016 | -011 | | A 310 pF Pi |
| 56-713-007 | -017 | -012 | | B 1000 pF C |
| 56-713-008 | -018 | -013 | | C 1000 pF Pi |
| 56-713-009 | -019 | -014 | | D 5000 pF C |
| 56-713-010 | -020 | -015 | | E 4000 pF Pi |
| 56-713-030 | -027 | -024 | | F 830 pF C |
| 56-713-031 | -028 | -025 | | J 100 pF Pi |
| 56-713-032 | -029 | -026 | | K 2500 pF Pi |
| 56-713-040 | -039 | -038 | | N 375 pF C |

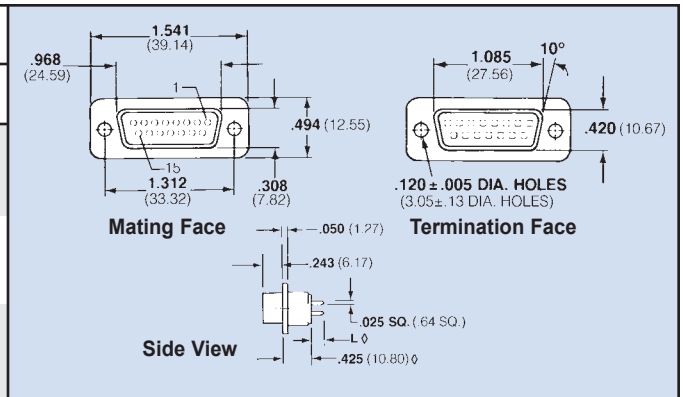

Solder Cup Termination

| Spectrum Part Number | EMI Filter | |
|----------------------|----------------------|------------|
| | Filter Designation** | Cap. Value |
| * 56-716-001 | A | 310 pF Pi |
| 56-716-002 | B | 1000 pF C |
| * 56-716-003 | C | 1000 pF Pi |
| 56-716-004 | D | 5000 pF C |
| * 56-716-005 | E | 4000 pF Pi |
| 56-716-006 | F | 830 pF C |
| 56-716-007 | J | 100 pF Pi |
| * 56-716-008 | K | 2500 pF Pi |
| 56-716-009 | N | 375 pF C |
| 56-716-013 | L | 500 pF C |

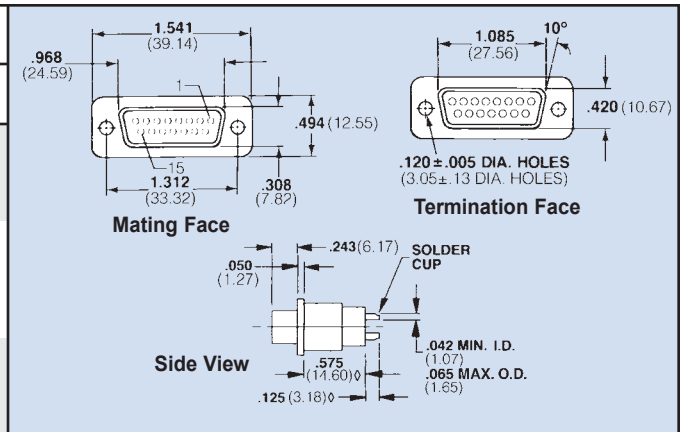

Pin/Socket Adapter

| Spectrum Part Number | EMI Filter | |
|----------------------|----------------------|------------|
| | Filter Designation** | Cap. Value |
| * 56-715-001 | A | 310 pF Pi |
| 56-715-002 | B | 1000 pF C |
| * 56-715-003 € | C | 1000 pF Pi |
| 56-715-004 | D | 5000 pF C |
| * 56-715-005 € | E | 4000 pF Pi |
| 56-715-007 | F | 830 pF C |
| 56-715-008 | J | 100 pF Pi |
| 56-715-009 | K | 2500 pF Pi |
| 56-715-015 | N | 375 pF C |
| 56-715-040 | L | 500 pF C |

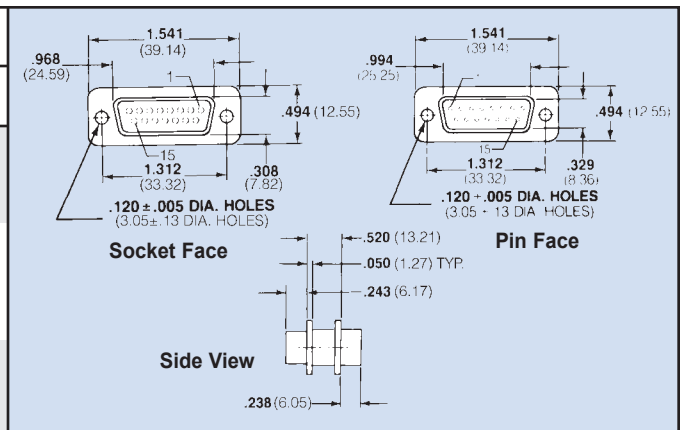

€ Also available through API's authorized European distributors/agents.

* May be available from distributor stock.

** See page FC20 for filter performance.

Standard Tolerance = ±.005 except where noted, ∅ = ±.015

API TECHNOLOGIES • 8061 Avonia Rd. • Fairview, PA 16415 • Ph: 814-474-1571 • Fax: 814-474-3110 • eis.apitech.com

API TECHNOLOGIES' SPECTRUM CONTROL GmbH • Hansastrasse 6 • 91126 Schwabach, Germany • Phone: (49)-9122-795-0 • Fax: (49)-9122-795-58

Dimensions in inches (mm)

25 Series 700 Shell Size Pin Contact



Printed Circuit Board Mount

| Spectrum Part Number | EMI Filter | |
|----------------------|----------------------|------------|
| | Filter Designation** | Cap. Value |
| 56-721-001 | A | 310 pF Pi |
| 56-721-002 | B | 1000 pF C |
| 56-721-003 | C | 1000 pF Pi |
| 56-721-004 | D | 5000 pF C |
| 56-721-005 | E | 4000 pF Pi |
| 56-721-033 | F | 830 pF C |
| 56-721-034 | J | 100 pF Pi |
| 56-721-035 | K | 2500 pF Pi |
| 56-721-063 | N | 375 pF C |
| 56-721-111 | L | 500 pF C |

Mating Face

Termination Face

Side View

Printed Circuit Board Right Angle Mount

| Spectrum Part Number | EMI Filter | |
|----------------------|----------------------|------------|
| | Filter Designation** | Cap. Value |
| * 56-722-001 | A | 310 pF Pi |
| 56-722-002 | B | 1000 pF C |
| * 56-722-003 | C | 1000 pF Pi |
| 56-722-004 | D | 5000 pF C |
| * 56-722-005 | E | 4000 pF Pi |
| * 56-722-008 | F | 830 pF C |
| 56-722-009 | J | 100 pF Pi |
| 56-722-010 | K | 2500 pF Pi |
| 56-722-027 | N | 375 pF C |
| 56-722-060 | L | 500 pF C |

Mating Face

Termination Face

Bottom View

Side View

* May be available from distributor stock.
 ** See page FC20 for filter performance.
 Standard Tolerance = ±.005 except where noted, ∅ = ±.015

Dimensions in inches (mm)

25 Series 700 Shell Size Pin Contact



Solderless Wire Wrap

| Spectrum Part Number <i>Select one</i> | EMI Filter | | | | |
|---|------------|-----------|-----------|--------------------|------------|
| | L .500 | L .375 | L .250 | Filter Desig.** | Cap. Value |
| 56-721 -006 -028 -024 | | | | A | 310 pF Pi |
| 56-721 -007 -029 -025 | | | | B | 1000 pF C |
| 56-721 -008 -030 -026 | | | | C | 1000 pF Pi |
| 56-721 -009 -031 -022 | | | | D | 5000 pF C |
| 56-721 -010 -032 -027 | | | | E | 4000 pF Pi |
| 56-721 -042 -039 -036 | | | | F | 830 pF C |
| 56-721 -043 -040 -037 | | | | J | 100 pF Pi |
| 56-721 -044 -041 -038 | | | | K | 2500 pF Pi |
| 56-721 -066 -065 -064 | | | | N | 375 pF C |

Mating Face

Termination Face

Side View

Solder Cup Termination

| Spectrum Part Number | EMI Filter | |
|----------------------|----------------------|------------|
| | Filter Designation** | Cap. Value |
| * 56-721-011 | A | 310 pF Pi |
| * 56-721-012 | B | 1000 pF C |
| * 56-721-013 | C | 1000 pF Pi |
| 56-721-014 | D | 5000 pF C |
| * 56-721-015 | E | 4000 pF Pi |
| * 56-721-045 | F | 830 pF C |
| 56-721-046 | J | 100 pF Pi |
| 56-721-047 | K | 2500 pF Pi |
| 56-721-070 | N | 375 pF C |
| 56-721-112 | L | 500 pF C |

Mating Face

Termination Face

Side View

* May be available from distributor stock.
 ** See page FC20 for filter performance.
 Standard Tolerance = ±.005 except where noted, ∅ = ±.015

Dimensions in inches (mm)

25 Series 700 Shell Size Socket Contact

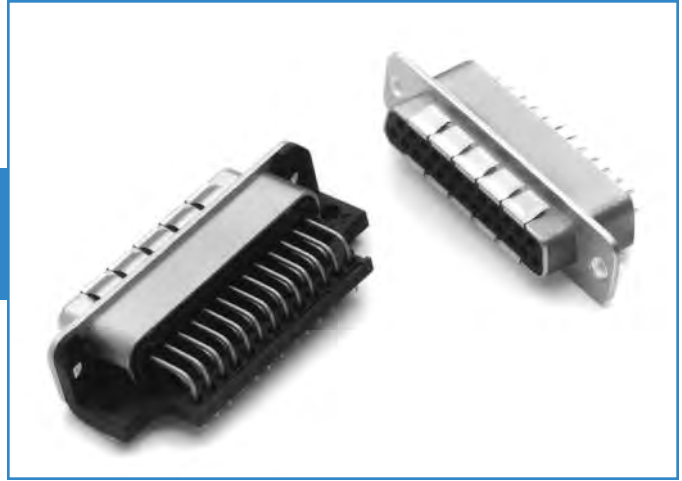

Printed Circuit Board Mount

| Spectrum Part Number | EMI Filter | |
|----------------------|----------------------|------------|
| | Filter Designation** | Cap. Value |
| 56-723-001 | A | 310 pF Pi |
| 56-723-002 | B | 1000 pF C |
| 56-723-003 | C | 1000 pF Pi |
| 56-723-004 | D | 5000 pF C |
| 56-723-005 | E | 4000 pF Pi |
| 56-723-023 | F | 830 pF C |
| 56-723-024 | J | 100 pF Pi |
| 56-723-025 | K | 2500 pF Pi |
| 56-723-045 | N | 375 pF C |
| 56-723-069 | L | 500 pF C |

Printed Circuit Board Right Angle Mount

| Spectrum Part Number | EMI Filter | |
|----------------------|----------------------|------------|
| | Filter Designation** | Cap. Value |
| * 56-724-001 | A | 310 pF Pi |
| 56-724-002 | B | 1000 pF C |
| * 56-724-003 | C | 1000 pF Pi |
| 56-724-004 | D | 5000 pF C |
| * 56-724-005 | E | 4000 pF Pi |
| * 56-724-008 | F | 830 pF C |
| 56-724-009 | J | 100 pF Pi |
| 56-724-010 | K | 2500 pF Pi |
| 56-724-021 | N | 375 pF C |
| 56-724-046 | L | 500 pF C |

* May be available from distributor stock.

** See page FC20 for filter performance.

Standard Tolerance = ± 0.005 except where noted, $\diamond = \pm 0.015$

Dimensions in inches (mm)

25 Series 700 Shell Size Pin/Socket Adapter



Solderless Wire Wrap

| Spectrum Part Number <i>Select one</i> | EMI Filter | | | Filter Desig.** | Cap. Value |
|---|------------|-----------|-----------|-----------------|------------|
| | L .500 | L .375 | L .250 | | |
| * 56-723 -006 -017 * -012 | | | | A | 310 pF Pi |
| 56-723 -007 -018 -013 | | | | B | 1000 pF C |
| * 56-723 -008 -019 * -014 | | | | C | 1000 pF Pi |
| 56-723 -009 -020 -015 | | | | D | 5000 pF C |
| * 56-723 -010 -021 * -016 | | | | E | 4000 pF Pi |
| * 56-723 -032 -029 * -026 | | | | F | 830 pF C |
| 56-723 -033 -030 -027 | | | | J | 100 pF Pi |
| 56-723 -034 -031 -028 | | | | K | 2500 pF Pi |
| 56-723 -048 -047 -046 | | | | N | 375 pF C |

Solder Cup Termination

| Spectrum Part Number | EMI Filter | |
|----------------------|----------------------|------------|
| | Filter Designation** | Cap. Value |
| * 56-726-001 | A | 310 pF Pi |
| 56-726-002 | B | 1000 pF C |
| * 56-726-003 | C | 1000 pF Pi |
| 56-726-004 | D | 5000 pF C |
| * 56-726-005 | E | 4000 pF Pi |
| 56-726-006 | F | 830 pF C |
| 56-726-007 | J | 100 pF Pi |
| * 56-726-008 | K | 2500 pF Pi |
| 56-726-009 | N | 375 pF C |
| 56-726-021 | L | 500 pF C |

Pin/Socket Adapter

| Spectrum Part Number | EMI Filter | |
|----------------------|----------------------|------------|
| | Filter Designation** | Cap. Value |
| * 56-725-001 | A | 310 pF Pi |
| 56-725-002 | B | 1000 pF C |
| * 56-725-003 € | C | 1000 pF Pi |
| 56-725-004 | D | 5000 pF C |
| * 56-725-005 € | E | 4000 pF Pi |
| * 56-725-019 | F | 830 pF C |
| 56-725-020 | J | 100 pF Pi |
| * 56-725-021 | K | 2500 pF Pi |
| 56-725-064 | N | 375 pF C |
| 56-725-073 | L | 500 pF C |

€ Also available through API's authorized European distributors/agents.

* May be available from distributor stock.

** See page FC20 for filter performance.

Standard Tolerance = ±.005 except where noted, ∅ = ±.015

API TECHNOLOGIES • 8061 Avonia Rd. • Fairview, PA 16415 • Ph: 814-474-1571 • Fax: 814-474-3110 • eis.apitech.com

API TECHNOLOGIES' SPECTRUM CONTROL GmbH • Hansastrasse 6 • 91126 Schwabach, Germany • Phone: (49)-9122-795-0 • Fax: (49)-9122-795-58

Dimensions in inches (mm)

37 Series 700 Shell Size Pin Contact



Printed Circuit Board Mount

| Spectrum Part Number | EMI Filter | |
|----------------------|----------------------|------------|
| | Filter Designation** | Cap. Value |
| 56-731-001 | A | 310 pF Pi |
| 56-731-002 | B | 1000 pF C |
| 56-731-003 | C | 1000 pF Pi |
| 56-731-004 | D | 5000 pF C |
| 56-731-005 | E | 4000 pF Pi |
| 56-731-028 | F | 830 pF C |
| 56-731-029 | J | 100 pF Pi |
| 56-731-030 | K | 2500 pF Pi |
| 56-731-048 | N | 375 pF C |
| 56-731-076 | L | 500 pF C |

Printed Circuit Board Right Angle Mount

| Spectrum Part Number | EMI Filter | |
|----------------------|----------------------|------------|
| | Filter Designation** | Cap. Value |
| 56-732-001 | A | 310 pF Pi |
| 56-732-002 | B | 1000 pF C |
| * 56-732-003 | C | 1000 pF Pi |
| 56-732-004 | D | 5000 pF C |
| * 56-732-005 | E | 4000 pF Pi |
| 56-732-006 | F | 830 pF C |
| 56-732-007 | J | 100 pF Pi |
| 56-732-008 | K | 2500 pF Pi |
| 56-732-009 | N | 375 pF C |
| 56-732-023 | L | 500 pF C |

* May be available from distributor stock.
 ** See page FC20 for filter performance.
 Standard Tolerance = ±.005 except where noted, ∅ = ±.015

Dimensions in inches (mm)

37 Series 700 Shell Size Pin Contact



Solderless Wire Wrap

| Spectrum Part Number <i>Select one</i> | EMI Filter | | | | |
|---|------------|-----------|-----------|--------------------|------------|
| | L .500 | L .375 | L .250 | Filter Desig.** | Cap. Value |
| 56-731 -006 -023 -018 | | | | A | 310 pF Pi |
| 56-731 -007 -024 -019 | | | | B | 1000 pF C |
| 56-731 -008 -025 -020 | | | | C | 1000 pF Pi |
| 56-731 -009 -026 -021 | | | | D | 5000 pF C |
| 56-731 -010 -027 -022 | | | | E | 4000 pF Pi |
| 56-731 -037 -034 -031 | | | | F | 830 pF C |
| 56-731 -038 -035 -032 | | | | J | 100 pF Pi |
| 56-731 -039 -036 -033 | | | | K | 2500 pF Pi |
| 56-731 -051 -050 -049 | | | | N | 375 pF C |

Solder Cup Termination

| Spectrum Part Number | EMI Filter | |
|----------------------|----------------------|------------|
| | Filter Designation** | Cap. Value |
| * 56-731-011 | A | 310 pF Pi |
| 56-731-012 | B | 1000 pF C |
| * 56-731-013 | C | 1000 pF Pi |
| 56-731-014 | D | 5000 pF C |
| * 56-731-015 | E | 4000 pF Pi |
| * 56-731-040 | F | 830 pF C |
| 56-731-041 | J | 100 pF Pi |
| 56-731-042 | K | 2500 pF Pi |
| 56-731-060 | N | 375 pF C |
| 56-731-077 | L | 500 pF C |

* May be available from distributor stock.
 ** See page FC20 for filter performance.
 Standard Tolerance = ±.005 except where noted, φ = ±.015

Dimensions in inches (mm)

37 Series 700 Shell Size Socket Contact



Printed Circuit Board Mount

| Spectrum Part Number | EMI Filter | |
|----------------------|----------------------|------------|
| | Filter Designation** | Cap. Value |
| 56-733-001 | A | 310 pF Pi |
| 56-733-002 | B | 1000 pF C |
| 56-733-003 | C | 1000 pF Pi |
| 56-733-004 | D | 5000 pF C |
| 56-733-005 | E | 4000 pF Pi |
| 56-733-021 | F | 830 pF C |
| 56-733-022 | J | 100 pF Pi |
| 56-733-023 | K | 2500 pF Pi |
| 56-733-035 | N | 375 pF C |
| 56-733-046 | L | 500 pF C |

Mating Face

Side View

Termination Face

Printed Circuit Board Right Angle Mount

| Spectrum Part Number | EMI Filter | |
|----------------------|----------------------|------------|
| | Filter Designation** | Cap. Value |
| 56-734-001 | A | 310 pF Pi |
| 56-734-002 | B | 1000 pF C |
| 56-734-003 | C | 1000 pF Pi |
| 56-734-004 | D | 5000 pF C |
| 56-734-005 | E | 4000 pF Pi |
| 56-734-006 | F | 830 pF C |
| 56-734-007 | J | 100 pF Pi |
| 56-734-008 | K | 2500 pF Pi |
| 56-734-012 | N | 375 pF C |
| 56-734-021 | L | 500 pF C |

Mating Face

Side View

Termination Face

Bottom View

* May be available from distributor stock.

** See page FC20 for filter performance.

Standard Tolerance = ±.005 except where noted, ∅ = ±.015

Dimensions in inches (mm)

37 Series 700 Shell Size Socket Contact & Pin/Socket Adapter



Solderless Wire Wrap

| Spectrum Part Number <i>Select one</i> | EMI Filter | | | Filter Desig.** | Cap. Value | | |
|---|------------|-----------|-----------|--------------------|------------|--|--|
| | L .500 | L .375 | L .250 | | | | |
| * 56-733-006 | -016 | * -011 | A | 310 pF Pi | | | |
| 56-733-007 | -017 | -012 | B | 1000 pF C | | | |
| 56-733-008 | -018 | -013 | C | 1000 pF Pi | | | |
| 56-733-009 | -019 | -014 | D | 5000 pF C | | | |
| 56-733-010 | -020 | -015 | E | 4000 pF Pi | | | |
| 56-733-030 | -027 | -024 | F | 830 pF C | | | |
| 56-733-031 | -028 | -025 | J | 100 pF Pi | | | |
| 56-733-032 | -029 | -026 | K | 2500 pF Pi | | | |
| 56-733-038 | -037 | -036 | N | 375 pF C | | | |

Solder Cup Termination

| Spectrum Part Number | EMI Filter | | | |
|----------------------|----------------------|------------|--|--|
| | Filter Designation** | Cap. Value | | |
| * 56-736-001 | A | 310 pF Pi | | |
| 56-736-002 | B | 1000 pF C | | |
| * 56-736-003 | C | 1000 pF Pi | | |
| 56-736-004 | D | 5000 pF C | | |
| * 56-736-005 | E | 4000 pF Pi | | |
| 56-736-006 | F | 830 pF C | | |
| 56-736-007 | J | 100 pF Pi | | |
| * 56-736-008 | K | 2500 pF Pi | | |
| 56-736-009 | N | 375 pF C | | |
| 56-736-015 | L | 500 pF C | | |

Pin/Socket Adapter

| Spectrum Part Number | EMI Filter | | | |
|----------------------|----------------------|------------|--|--|
| | Filter Designation** | Cap. Value | | |
| * 56-735-001 | A | 310 pF Pi | | |
| 56-735-002 | B | 1000 pF C | | |
| * 56-735-003 € | C | 1000 pF Pi | | |
| 56-735-004 | D | 5000 pF C | | |
| * 56-735-005 € | E | 4000 pF Pi | | |
| * 56-735-008 | F | 830 pF C | | |
| 56-735-009 | J | 100 pF Pi | | |
| 56-735-010 | K | 2500 pF Pi | | |
| 56-735-025 | N | 375 pF C | | |
| 56-735-034 | L | 500 pF C | | |

€ Also available through API's authorized European distributors/agents.

* May be available from distributor stock.

** See page FC20 for filter performance.

Standard Tolerance = ±.005 except where noted, ∅ = ±.015

API TECHNOLOGIES • 8061 Avonia Rd. • Fairview, PA 16415 • Ph: 814-474-1571 • Fax: 814-474-3110 • eis.apitech.com

API TECHNOLOGIES' SPECTRUM CONTROL GmbH • Hansastrasse 6 • 91126 Schwabach, Germany • Phone: (49)-9122-795-0 • Fax: (49)-9122-795-58

Dimensions in inches (mm)

50 Series 700 Shell Size Pin Contact



Printed Circuit Board Mount

| Spectrum Part Number | EMI Filter | |
|----------------------|----------------------|------------|
| | Filter Designation** | Cap. Value |
| 56-741-001 | A | 310 pF Pi |
| 56-741-002 | B | 1000 pF C |
| 56-741-003 | C | 1000 pF Pi |
| 56-741-004 | D | 5000 pF C |
| 56-741-005 | E | 4000 pF Pi |
| 56-741-027 | F | 830 pF C |
| 56-741-028 | J | 100 pF Pi |
| 56-741-029 | K | 2500 pF Pi |
| 56-741-042 | N | 375 pF C |
| 56-741-066 | L | 500 pF C |

Mating Face

Termination Face

Side View

Printed Circuit Board Right Angle Mount

| Spectrum Part Number | EMI Filter | |
|----------------------|----------------------|------------|
| | Filter Designation** | Cap. Value |
| 56-742-001 | A | 310 pF Pi |
| 56-742-002 | B | 1000 pF C |
| 56-742-003 | C | 1000 pF Pi |
| 56-742-004 | D | 5000 pF C |
| 56-742-005 | E | 4000 pF Pi |
| 56-742-006 | F | 830 pF C |
| 56-742-007 | J | 100 pF Pi |
| 56-742-008 | K | 2500 pF Pi |
| 56-742-009 | N | 375 pF C |
| 56-742-022 | L | 500 pF C |

Mating Face

Termination Face

Side View

Bottom View

* May be available from distributor stock.
 ** See page FC20 for filter performance.
 Standard Tolerance = ±.005 except where noted, ∅ = ±.015

Dimensions in inches (mm)

50 Series 700 Shell Size Pin Contact



Solderless Wire Wrap

| Spectrum Part Number <i>Select one</i> | EMI Filter | | | | |
|---|------------|-----------|-----------|--------------------|------------|
| | L .500 | L .375 | L .250 | Filter Desig.** | Cap. Value |
| 56-741 -006 -022 -017 | | | | A | 310 pF Pi |
| 56-741 -007 -023 -018 | | | | B | 1000 pF C |
| 56-741 -008 -024 -019 | | | | C | 1000 pF Pi |
| 56-741 -009 -025 -020 | | | | D | 5000 pF C |
| 56-741 -010 -026 -021 | | | | E | 4000 pF Pi |
| 56-741 -036 -033 -030 | | | | F | 830 pF C |
| 56-741 -037 -034 -031 | | | | J | 100 pF Pi |
| 56-741 -038 -035 -032 | | | | K | 2500 pF Pi |
| 56-741 -045 -044 -043 | | | | N | 375 pF C |

Mating Face

Termination Face

Side View

Solder Cup Termination

| Spectrum Part Number | EMI Filter | |
|----------------------|----------------------|------------|
| | Filter Designation** | Cap. Value |
| * 56-741-011 | A | 310 pF Pi |
| * 56-741-012 | B | 1000 pF C |
| * 56-741-013 | C | 1000 pF Pi |
| * 56-741-014 | D | 5000 pF C |
| * 56-741-015 | E | 4000 pF Pi |
| 56-741-039 | F | 830 pF C |
| 56-741-040 | J | 100 pF Pi |
| 56-741-041 | K | 2500 pF Pi |
| 56-741-063 | N | 375 pF C |
| 56-741-067 | L | 500 pF C |

Mating Face

Termination Face

Side View

* May be available from distributor stock.
 ** See page FC20 for filter performance.
 Standard Tolerance = ±.005 except where noted, ◇ = ±.015

Dimensions in inches (mm)

50 Series 700 Shell Size Socket Contact



Printed Circuit Board Mount

| Spectrum Part Number | EMI Filter | |
|----------------------|----------------------|------------|
| | Filter Designation** | Cap. Value |
| 56-743-001 | A | 310 pF Pi |
| 56-743-002 | B | 1000 pF C |
| 56-743-003 | C | 1000 pF Pi |
| 56-743-004 | D | 5000 pF C |
| 56-743-005 | E | 4000 pF Pi |
| 56-743-021 | F | 830 pF C |
| 56-743-022 | J | 100 pF Pi |
| 56-743-023 | K | 2500 pF Pi |
| 56-743-033 | N | 375 pF C |
| 56-743-043 | L | 500 pF C |

Mating Face

Side View

Termination Face

Printed Circuit Board Right Angle Mount

| Spectrum Part Number | EMI Filter | |
|----------------------|----------------------|------------|
| | Filter Designation** | Cap. Value |
| 56-744-001 | A | 310 pF Pi |
| 56-744-002 | B | 1000 pF C |
| 56-744-003 | C | 1000 pF Pi |
| 56-744-004 | D | 5000 pF C |
| 56-744-005 | E | 4000 pF Pi |
| 56-744-006 | F | 830 pF C |
| 56-744-007 | J | 100 pF Pi |
| 56-744-008 | K | 2500 pF Pi |
| 56-744-009 | N | 375 pF C |
| 56-744-012 | L | 500 pF C |

Mating Face

Side View

Termination Face

Bottom View

* May be available from distributor stock.
 ** See page FC20 for filter performance.
 Standard Tolerance = ±.005 except where noted, ∅ = ±.015

Dimensions in inches (mm)

50 Series 700 Shell Size Pin/Socket Adapter



Solderless Wire Wrap

| Spectrum Part Number | Select one | | | EMI Filter | |
|----------------------|------------|-----------|-----------|--------------------|------------|
| | L .500 | L .375 | L .250 | Filter Desig.** | Cap. Value |
| 56-743 | -006 | -016 | -011 | A | 310 pF Pi |
| 56-743 | -007 | -017 | -012 | B | 1000 pF C |
| 56-743 | -008 | -018 | -013 | C | 1000 pF Pi |
| 56-743 | -009 | -019 | -014 | D | 5000 pF C |
| 56-743 | -010 | -020 | -015 | E | 4000 pF Pi |
| 56-743 | -030 | -027 | -024 | F | 830 pF C |
| 56-743 | -031 | -028 | -025 | J | 100 pF Pi |
| 56-743 | -032 | -029 | -026 | K | 2500 pF Pi |
| 56-743 | -036 | -035 | -034 | N | 375 pF C |

Mating Face

Termination Face

Side View

Solder Cup Termination

| Spectrum Part Number | EMI Filter | |
|----------------------|----------------------|------------|
| | Filter Designation** | Cap. Value |
| 56-746-001 | A | 310 pF Pi |
| 56-746-002 | B | 1000 pF C |
| 56-746-003 | C | 1000 pF Pi |
| 56-746-004 | D | 5000 pF C |
| 56-746-005 | E | 4000 pF Pi |
| 56-746-006 | F | 830 pF C |
| 56-746-007 | J | 100 pF Pi |
| 56-746-008 | K | 2500 pF Pi |
| 56-746-009 | N | 375 pF C |
| 56-746-018 | L | 500 pF C |

Mating Face

Termination Face

Side View

Pin/Socket Adapter

| Spectrum Part Number | EMI Filter | |
|----------------------|----------------------|------------|
| | Filter Designation** | Cap. Value |
| * 56-745-001 | A | 310 pF Pi |
| 56-745-002 | B | 1000 pF C |
| * 56-745-003 | C | 1000 pF Pi |
| 56-745-004 | D | 5000 pF C |
| * 56-745-005 | E | 4000 pF Pi |
| 56-745-006 | F | 830 pF C |
| 56-745-007 | J | 100 pF Pi |
| 56-745-008 | K | 2500 pF Pi |
| 56-745-019 | N | 375 pF C |
| 56-745-027 | L | 500 pF C |

Socket Face

Pin Face

Side View

* May be available from distributor stock.
 ** See page FC20 for filter performance.
 Standard Tolerance = ±.005 except where noted, ∅ = ±.015

Dimensions in inches (mm)

D-Subminiature Part Numbering System

Ordering Information

Example: **56-513-012-TI**

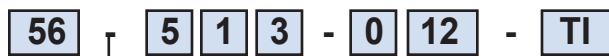

56 - Filtered D-Subminiature Connectors
 - Standard connector
 F - RoHS compliant version

5 - Product Series
 4 = Series F Ferrite
 5 = Series 500 Low Profile
 6 = Series 600 Hi-Density
 7 = Series 700 High Performance

1 - Shell Size
Series 400 & Series 500
 0 = 9 Contacts
 1 = 15 Contacts
 2 = 25 Contacts
 3 = 37 Contacts
Series 600 Hi-Density
 0 = 15 Contacts
 1 = 26 Contacts
 2 = 44 Contacts
 3 = 62 Contacts
 4 = 78 Contacts
Series 700
 0 = 9 Contacts
 1 = 15 Contacts
 2 = 25 Contacts
 3 = 37 Contacts
 4 = 50 Contacts

3 - Contact Type/Termination
 1 = Pin to solder cup
 2 = Pin to 90° PCB mount
 3 = Socket to straight PCB mount
 4 = Socket to 90° PCB mount
 5 = Pin-socket adapter
 6 = Socket to solder cup
 7 = Pin to straight PCB mount
 Styles available for:
Series 400 only 2, 3, 4, 7
Series 500 only 2, 3, 4 & 7
Series 600 only 1, 2, 3, 4, 5
Series 700 1 thru 7
Note: 1 can be Pin to solder cup or Pin to PCB for Series 700. See charts pages FC22-FC41.

0 - Line Filtering
 0 = All positions same
 9 = Special loading (Series 600 only)

12 - Capacitance Value
Series 400
 01 = Always
Series 500
 10 = 120 pF
 11 = 440 pF
 12 = 840 pF
 13 = 1000 pF
 14 = 1500 pF
Series 600
 15 = 85 pF FT
 16 = 180 pF FT
 18 = 1000 pF FT
 19 = 4000 pF FT
 20 = Insulated contact
Series 700
 See filter specification chart on page FC20 and select part numbers from Series 700 charts pages FC22-FC41.

TI - Options
 See options descriptions on page FC43 add suffix ending
Series F
 HD = Hi-Density (15 socket only)
Series 500
 TI = 4-40 threads on mounting flange (.125" hole if not selected)
 GBL = Grounded board lock includes 4-40 threads (available only on 90° PCB)
 GBLF = Grounded board lock and ferrite slab provides enhanced LC performance. (Available only on 90° PCB)
Series 600 Hi-Density
 LI = 4-40 UNC inserts
 S = Solder dipped tails
 50G = 50 μ (1.27 μm) gold
 GBL = Ground board lock
Series 700
 LI = 4-40 UNC inserts
 LIM = Metric M3.0 self-locking threads
 GB = Metal bracket provides ground connection, includes 4-40 self-locking threads (for right angle mount only)
 GBL = Grounded board lock (right angle)
 GBL6 = for .062" boards (straight PCB mount) (1.57mm)
 GBL9 = for .093" boards (straight PCB mount) (2.36mm)
 50G = 50 μ (1.27 μm) gold plating
 S = Solder dipped tails
 JS = Jackscrew mounting
 For option combinations, consult factory.

To assist your efforts in selecting the correct Filtered Connector to meet your needs, we have developed a part numbering system. All of the standard products are shown in their respective catalog pages.

Part number **56-513-012-TI** represents a Series 500 connector with 15 contacts in a socket to straight PCB mount configuration. All connector positions have a capacitance value of 840 pF and there are 4-40 threads on mounting flange.

D-Subminiature Connector Options

Threaded Inserts

Available on Series 500, 600 & 700

- #4-40 UNC or metric M3.0 threaded inserts in mounting flanges
- Allows ease of panel-assembly
- Plated steel inserts with last thread upset for torque

Grounding Bracket

For right angle mount PCB connectors, available on Series 700

- Metal bracket in place of plastic
- Provides ground connection direct from circuit board
- Allows shell grounding to board
- Includes 4-40 threads

Stand-off with Board Lock Feature

For straight PCB connectors, available on Series 700

- Allows shell grounding to board
- Eliminates stress on filter terminations
- Tin plated brass stand-off with snap-in feature
- Available for .062" (1.57mm) or .093" (2.36mm) thick boards

Grounding Bracket with Board Lock

For right angle mount PCB connectors, available on Series 500 & 700

- Metal bracket provides grounding
- Snap-in, no hardware needed, 4-40 threads included
- For use on .062" (1.57mm) thick boards

Gold Plating

Available on Series 600 & 700

- High reliability applications, 50µ" (1.27 µm) gold over 50µ" (1.27 µm) nickel

Solder Dipped Tails

Available on Series 600 & 700 connectors

- Solder dipped tails added to standard gold flash

Water Block

Consult API engineers for specifics.

- Internally sealed in accordance with NEMA Standard Rain Test section 6.4 (also UL50 part 28 ram test for submersion, section 6.10.1)

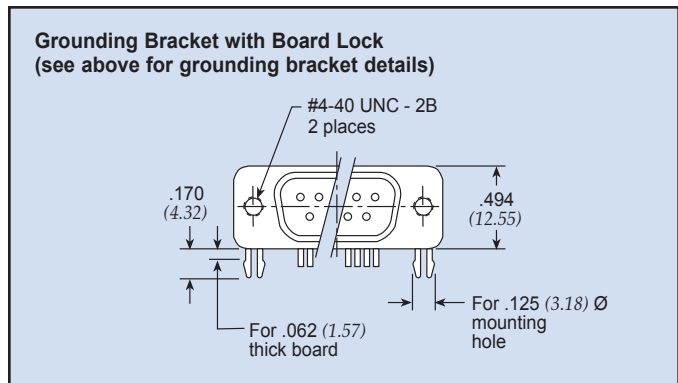
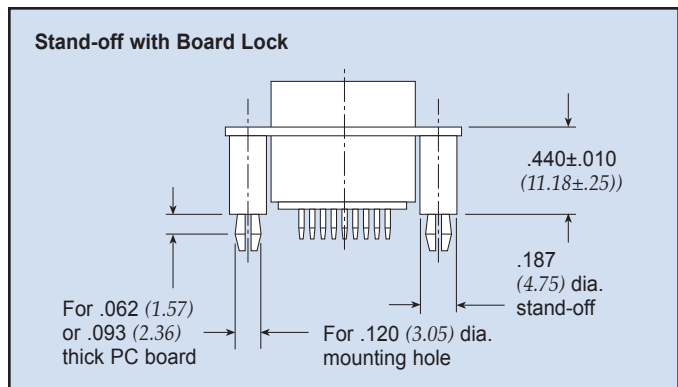
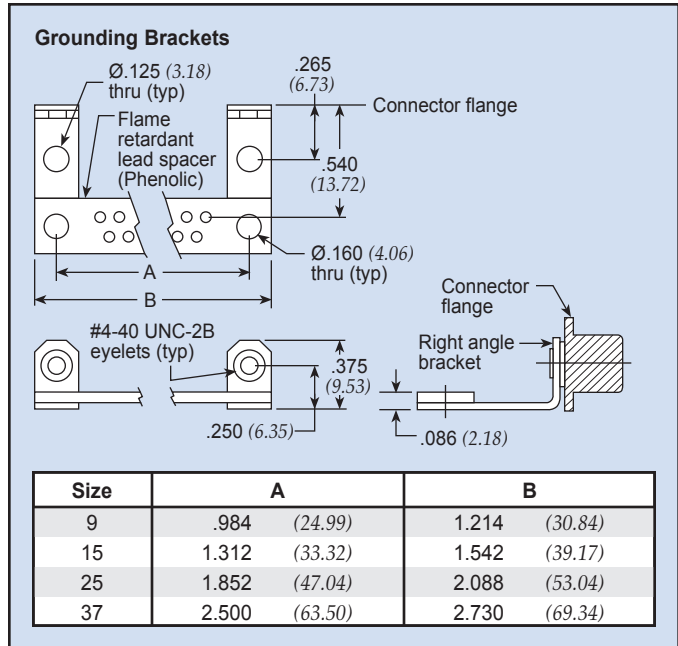
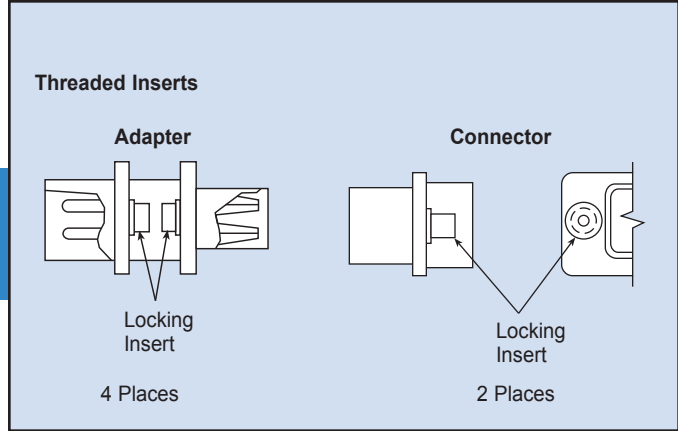

Dimensions in inches (mm)

Filtered Combo D-Subminiature Connectors

API's Spectrum Control line of filtered combo D-sub provide high insertion loss with capacitive filtering. These connectors are available with 20 Amp power contacts or 40 Amp power contacts. Configurations include male and female versions with straight PC terminals, right angle PC terminals or solder cup terminals. Standard D-sub shell sizes provide intermateability with unfiltered connectors. High strength epoxy potting protects ceramic elements.

Capacitive filtering is available in 470, 820, 1000 and 1500 pF. Additional capacitance ranges and configurations can be provided upon request. Please consult factory for more information.

Applications

- Telecommunications base station equipment
- Switching and transmission equipment
- Power supplies
- Industrial equipment
- Computer work stations

Ordering Information

Example: **563A03W3101GBL9**

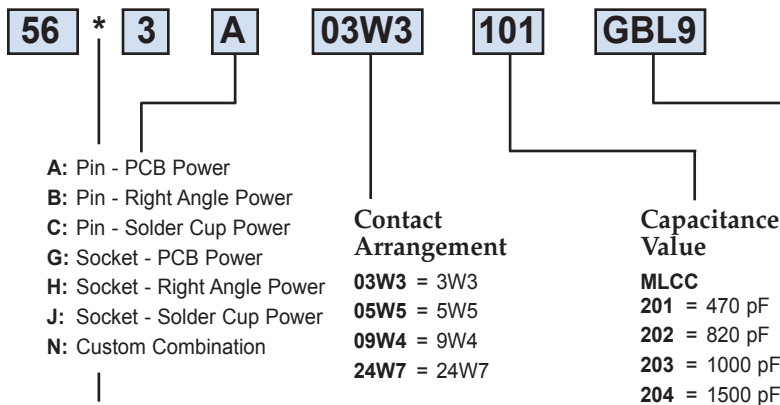

* Insert "F" for RoHS compliant

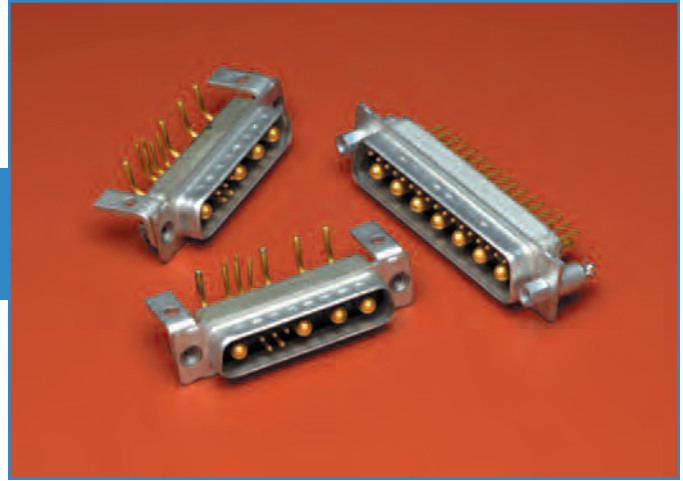

Mechanical Specifications

| | |
|-----------------------|--|
| Shell | Steel, tin plated |
| Power Contacts | Brass, gold plated .000030 in. (0.762 μm) minimum |
| Signal Contacts | Pin: brass, gold plated .000015 in. (0.762 μm) min. Socket: copper alloy, gold plated .000030 in. (0.762 μm) min. |
| Insulator | Glass-filled polyester, flammability UL94V-0 |
| Operating Temperature | -55°C to +125°C |
| Capacitors | MLCC |

Electrical Specifications

| | |
|-----------------------|---|
| Operating Voltage | 200 VDC |
| Current Rating* | 40 Amp power/ 5 Amp signal |
| Insulation Resistance | 1 Gohm at 100 VDC |
| Capacitance | See below for MLCC values. For other capacitance values contact factory. |

| | |
|---------------------------------|---------|
| Dielectric Withstanding Voltage | 600 VDC |
|---------------------------------|---------|

*30 Amp available. Consult factory.

Options

See options descriptions on page FC43 add suffix ending

- LI** = 4-40 UNC inserts
- LIM** = Metric M3.0 self-locking threads
- GB** = Metal bracket provides ground connection, includes 4-40 self-locking threads (for right angle mount only)
- GBL** = Grounded board lock (right angle)
- GBL6** = for .062" boards (straight PCB mount)
- GBL9** = for .093" boards (straight PCB mount)
- 50G** = 50 μ (1.27 μm) gold plating
- S** = Solder dipped tails
- JS** = Jackscrew mounting

For option combinations, consult factory.

Filtered Combo D-Subminiature Connectors 3W3

Plug - Solder Cup

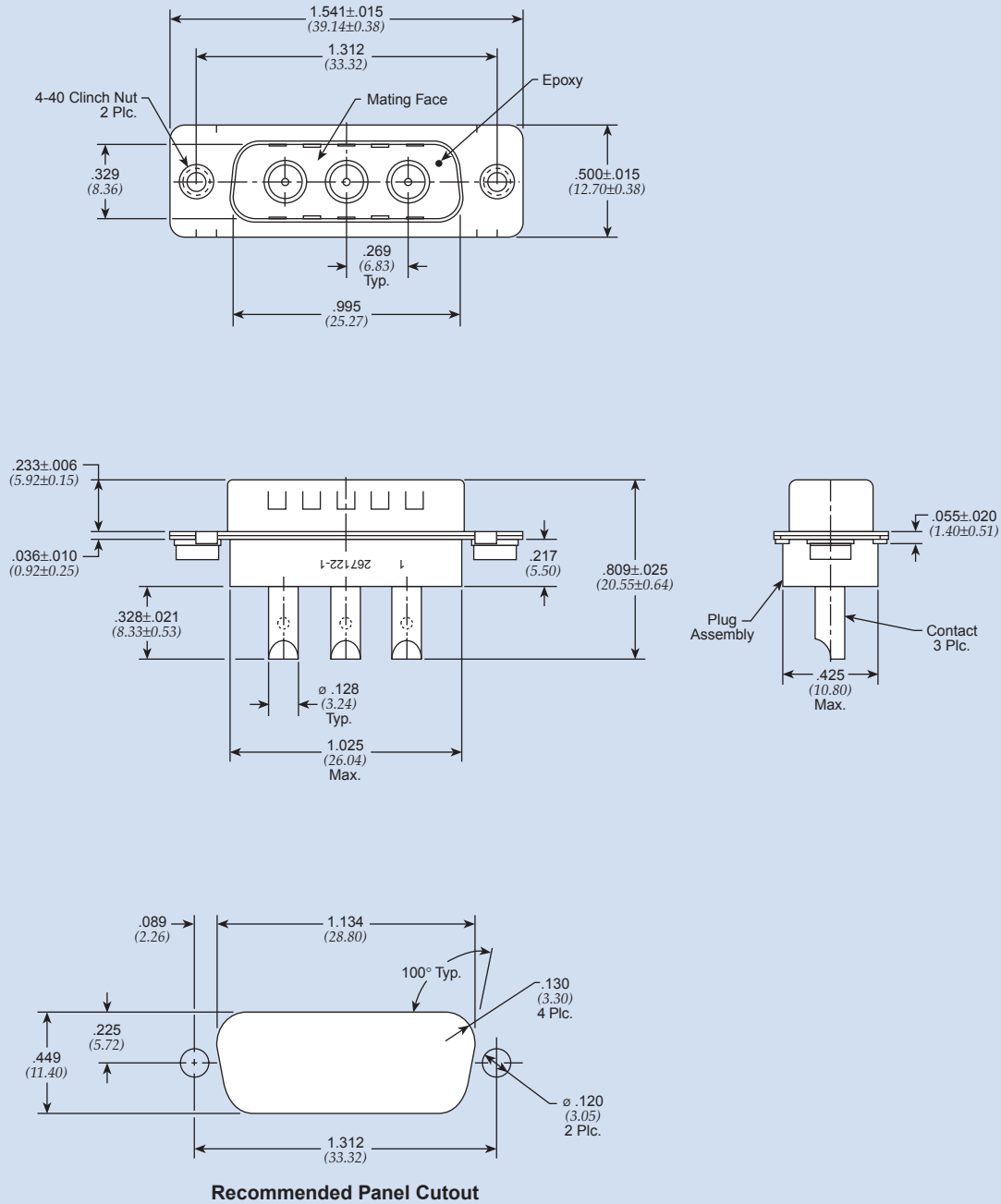

Only represents a few of our available configurations. Consult factory for more information.

Dimensions in inches (mm)

Filtered Combo D-Subminiature Connectors 3W3

Plug - Right Angle

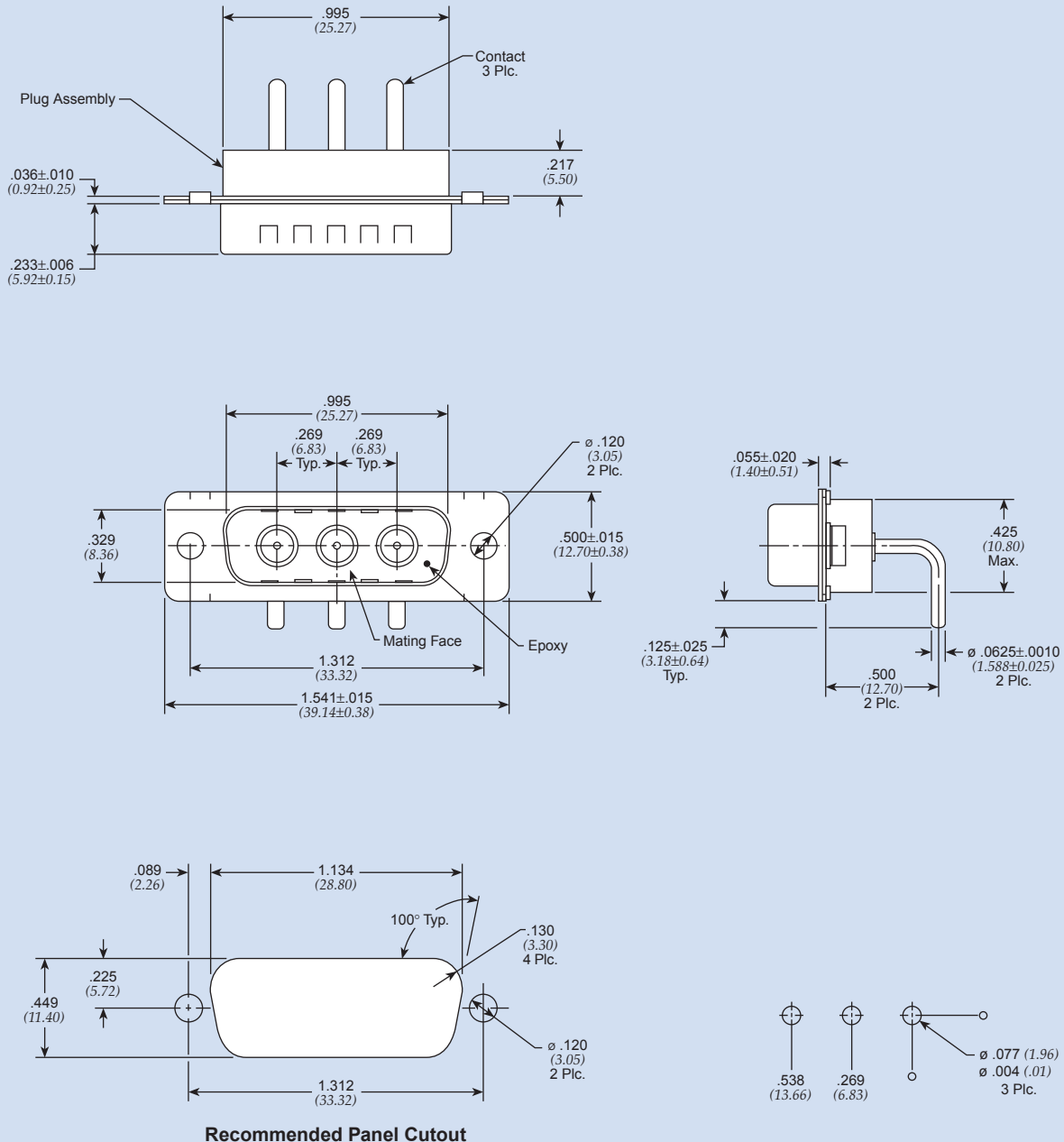

Only represents a few of our available configurations. Consult factory for more information.

Dimensions in inches (mm)

Filtered Combo D-Subminiature Connectors 5W5

Plug - Vertical

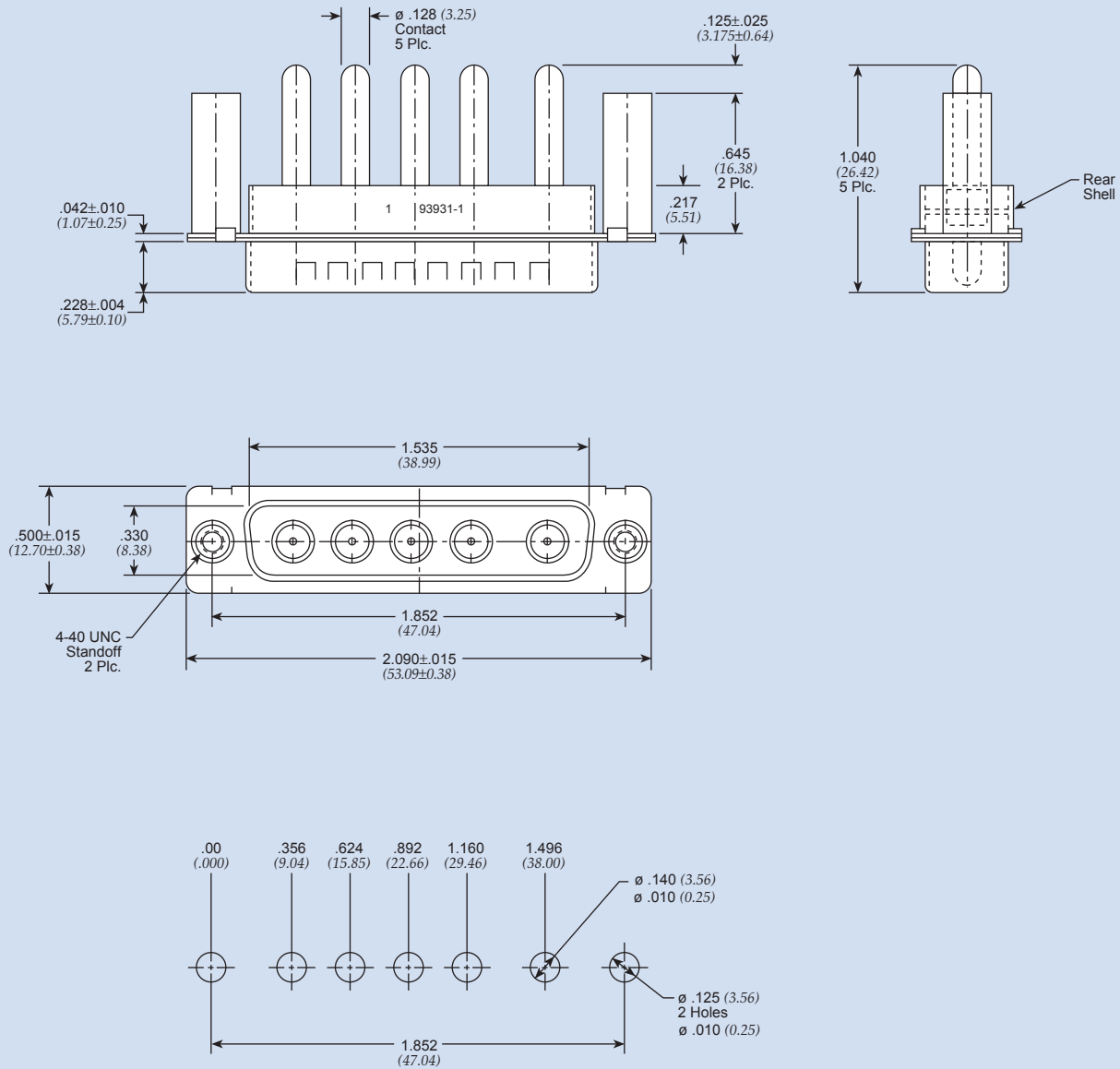

Recommended PCB Layout

Only represents a few of our available configurations. Consult factory for more information.

Dimensions in inches (mm)

Filtered Combo D-Subminiature Connectors 9W4

Socket - Solder Cup

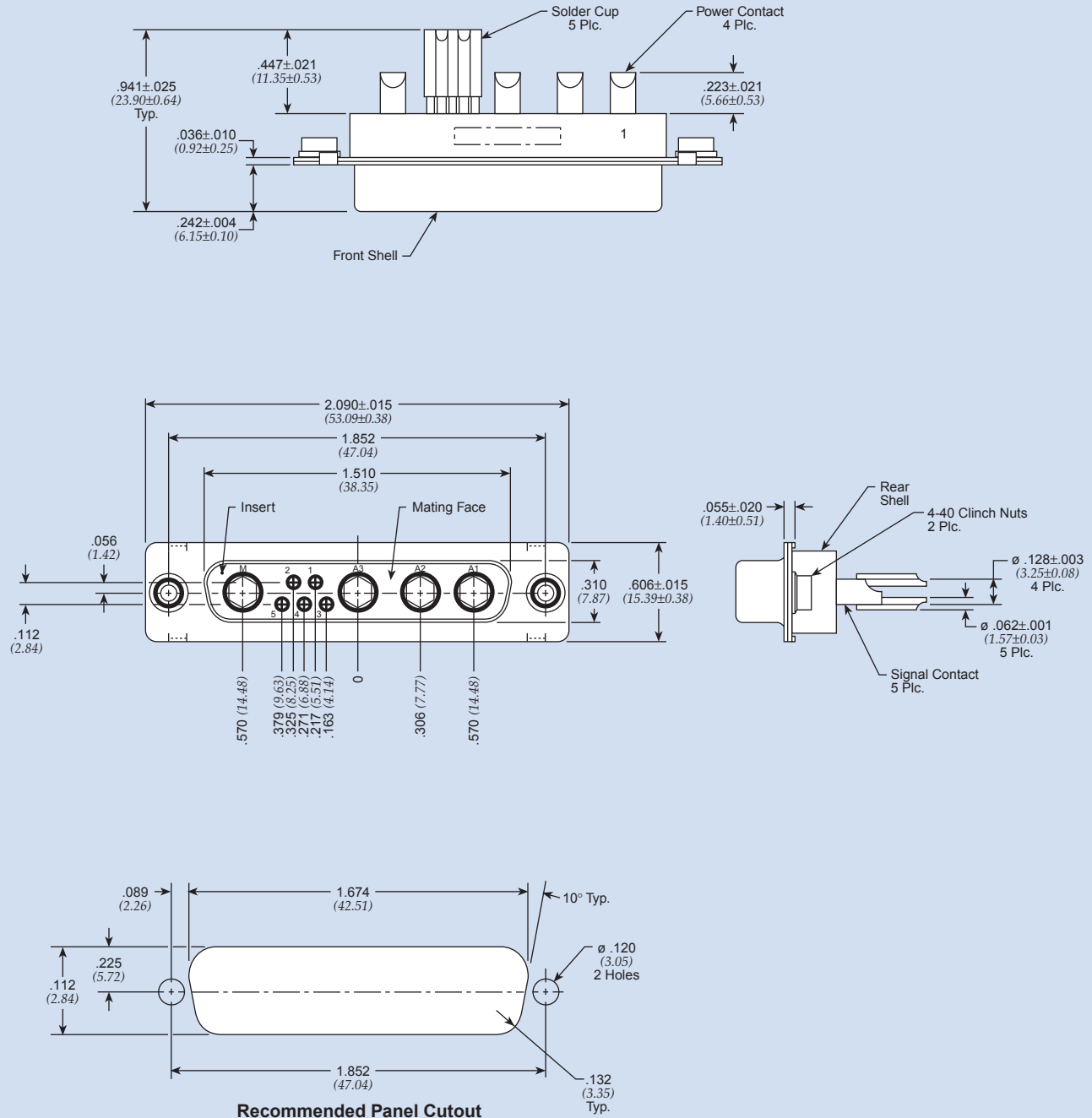

Only represents a few of our available configurations. Consult factory for more information.

Dimensions in inches (mm)

Filtered Combo D-Subminiature Connectors 9W4

Socket - Vertical

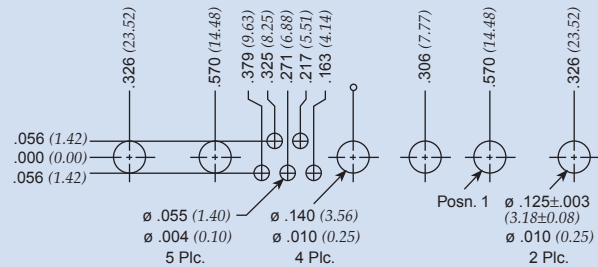
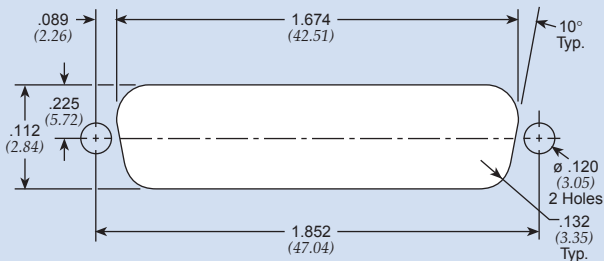
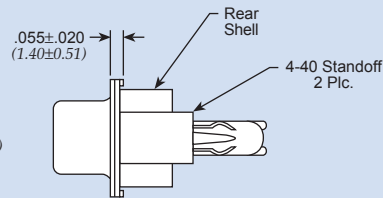
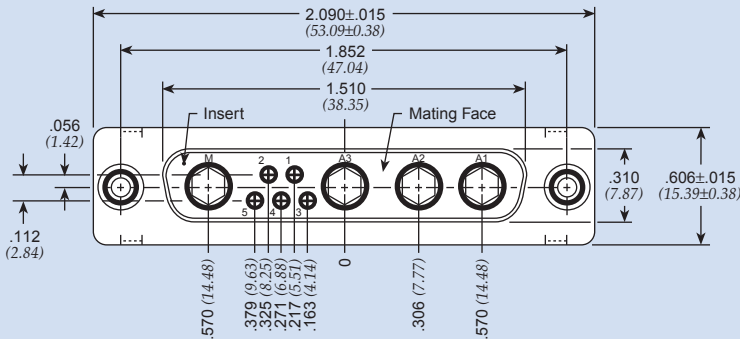
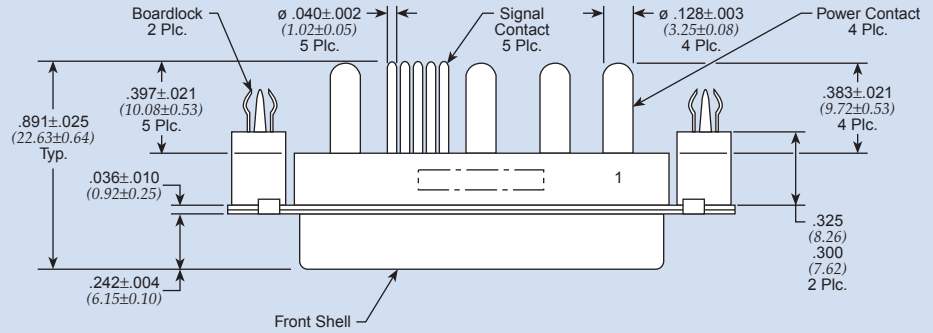

Only represents a few of our available configurations. Consult factory for more information.

Dimensions in inches (mm)

Filtered Combo D-Subminiature Connectors 9W4

Plug - Right Angle

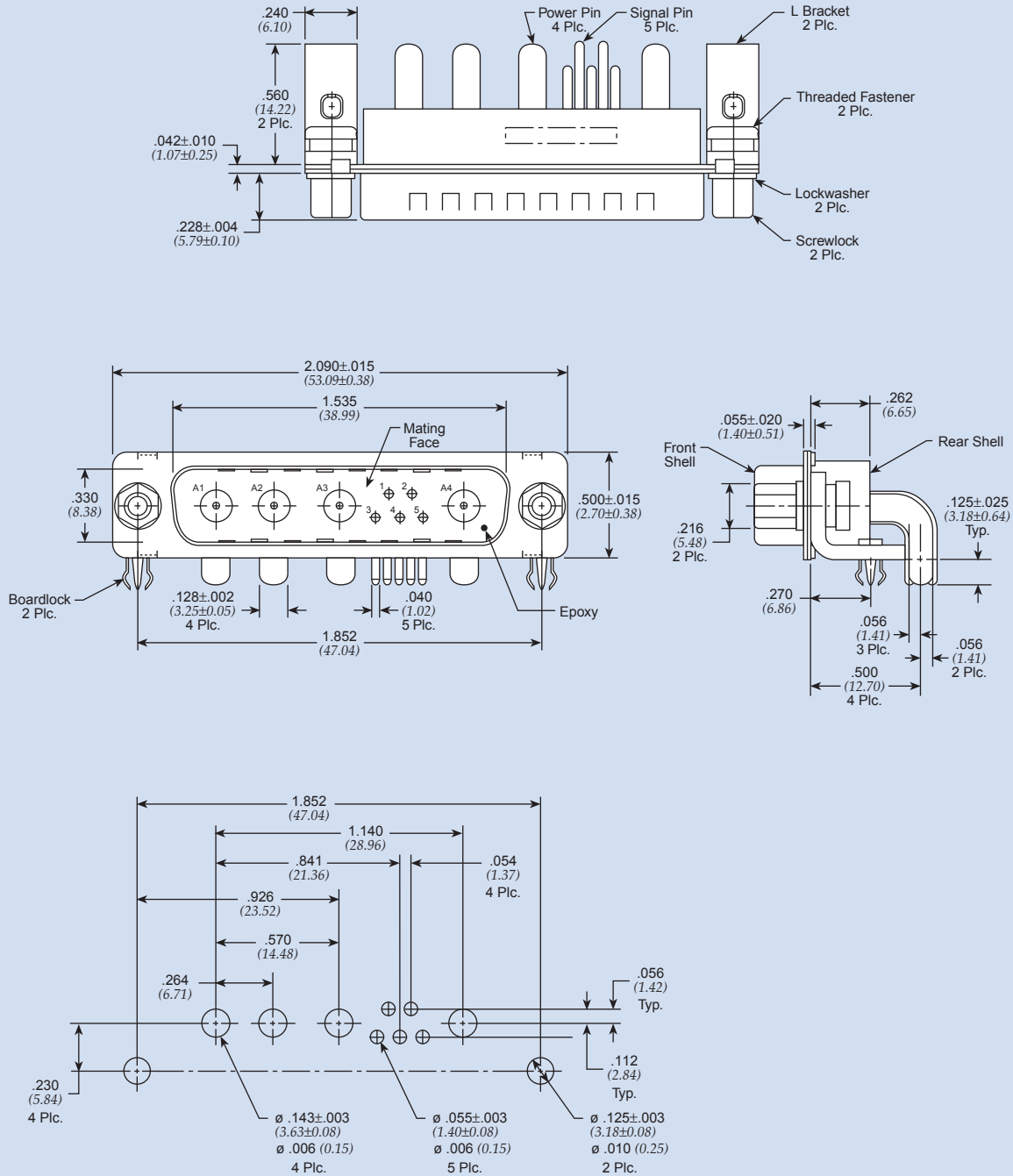

Only represents a few of our available configurations. Consult factory for more information.

Dimensions in inches (mm)

Filtered Combo D-Subminiature Connectors 24W7

Socket - Solder Cup

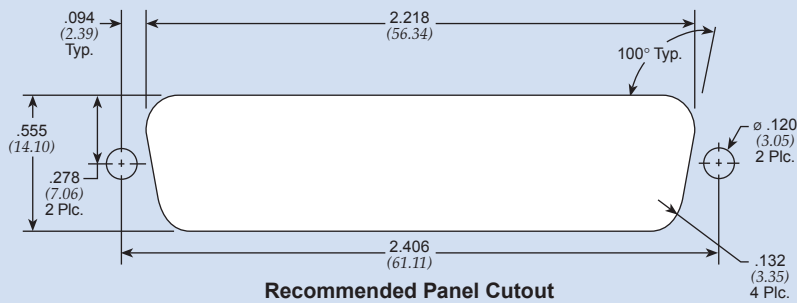
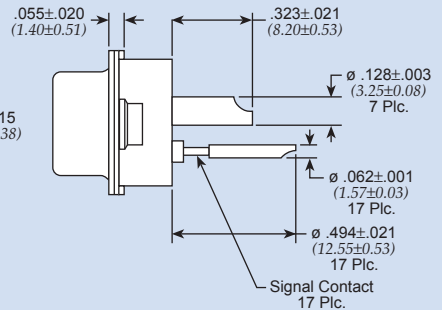
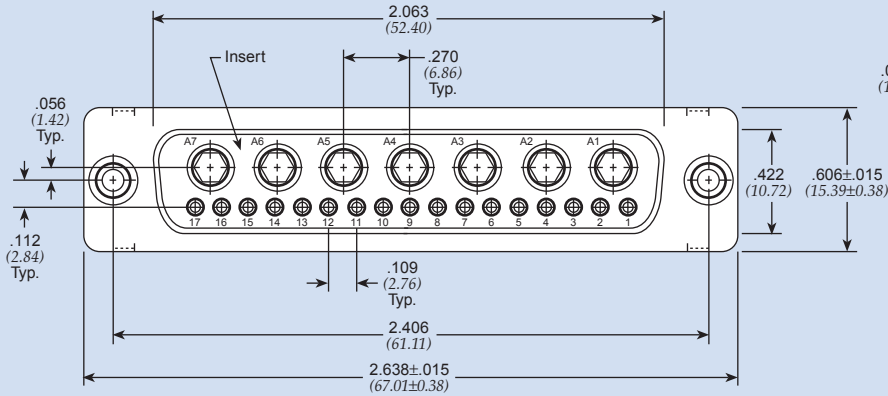
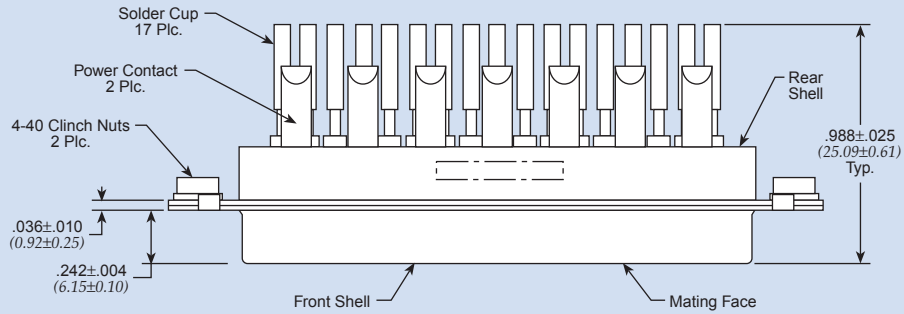

Only represents a few of our available configurations. Consult factory for more information.

Dimensions in inches (mm)

D-Subminiature Adapter Test Kit & Hardware

Adapter Test Kit

Specially designed for EMI evaluation process

- Male/female adapter part
- Easily plugged into equipment under testing conditions
- Ideal for new products and retrofitting
- Each adapter test kit includes:
 - 20 filtered adapters
 - Four shell sizes 9, 15, 25 and 37
 - Four filter ranges:
 - Series 700**
 - 310 pF Pi
 - 830 pF FT
 - 1000 pF Pi
 - 4000 pF Pi

Ordering Information

| Description | API Part Number |
|---|--------------------|
| Adapter test kit | 56-700-002 |
| Adapter test kit with Jackscrew <i>Includes 40 pcs. 56-201-006</i> | 56-700-002-JS |
| Hexagonal Spacer | 56-201-001 (1 per) |
| Jackscrew Mounting Hardware <i>For .312" (7.92 mm) length</i> | 56-201-004 (1 per) |
| Jackscrew Mounting Hardware <i>For .688" (17.47 mm) length</i> | 56-201-006 (2 per) |
| Tubular Spacer | 56-201-003 (1 per) |



Adapter Test Kit

Hardware

Designed to provide simple and effective mounting

Hexagonal Spacer

- Tapped spacer fits between flanges
- Provide retrofit of 4-40" threads
- Two spacers per adapter required, packaged in bulk

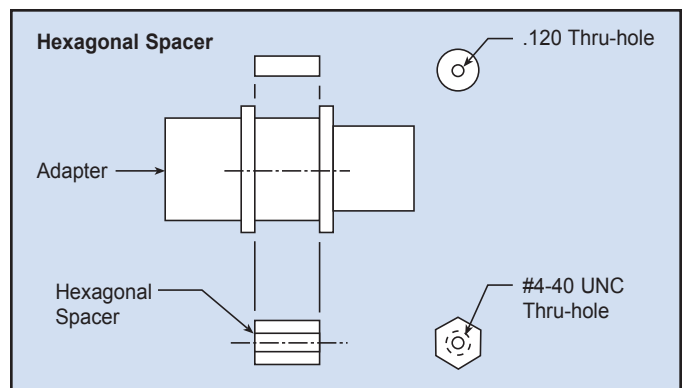

Jackscrew Mounting Hardware

- Male/female jackscrews
- Standard 4-40 threads for compatibility
- Two male thread lengths available
- Two screws per adapter required
- Lockwasher included, packaged in bulk

Micro D Series Filtered Connectors

For designs that require even smaller connector packages, API's Spectrum Control brand has designed a line of filtered Micro D-Subminiature connectors. This line of connectors offers a range of reliable filtering options, including capacitive and ESD versions, and several sizes and termination options. API has a Micro D-sub connector to satisfy your smallest space constraints.

Features

- Light weight
- Compact size
- Environmentally sealed contact area when mated
- Corrosion resistant
- Durable (500 cycles min.)
- Superior electrical performance
- RoHS compliant



Mechanical Specifications

| | |
|-----------------------------------|--|
| <i>Shell</i> | Aluminum, electroless nickel plated 500 μ in (12.7 μm) minimum |
| <i>Insulator</i> | High temperature plastic, flammability UL94V-0 |
| <i>Contacts</i> | Copper alloy, gold plated 50 μ in (1.27 μm) minimum |
| <i>Potting</i> | Flammability UL94V-0 |
| <i>Interfacial Seal</i> | Silicon |

Electrical Specifications

| | |
|--|-------------------|
| <i>Operating Voltage</i> | 100 VDC |
| <i>Dielectric Withstanding Voltage</i> | 300 VDC |
| <i>Current Rating</i> | 3 Amps |
| <i>Insulation Resistance</i> | 5G ohms @ 100 VDC |

Ordering Information

Example: **56-F011-110-JP**

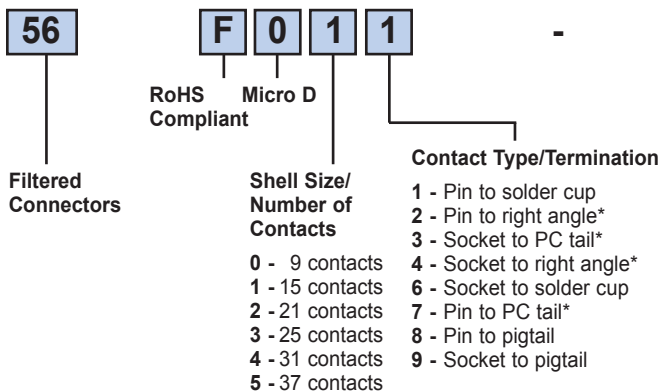

This part number represents a micro D-sub connector with a shell size of 15 and a pin to solder cup configuration. All lines are filtered with same capacitance value, which is 100 pF COB. The connector includes an optional #2-56 jack post.

* Right angle and PC tail length is 0.109. Other lengths available, consult factory.

All capacitance values ±20% @ 25°C

Micro D Series Filtered Connectors

High Performance

| Filter Designation | Type | Capacitance | | Dielectric Withstanding Voltage | Working Voltage DC -55°C to +125°C | Minimum Insertion Loss - Decibels (dB) 50 ohm system per MIL-STD-220 (no load) | | | | | | | |
|--------------------|------|-------------|-----------|---------------------------------|------------------------------------|--|--------|--------|--------|---------|---------|---------|-------|
| | | Value | Tolerance | | | 5 MHz | 10 MHz | 20 MHz | 50 MHz | 100 MHz | 200 MHz | 500 MHz | 1 GHz |
| 01 | FT | 100 pF | ±20% | 300V | 100V | — | — | — | — | 1 | 6 | 14 | 20 |
| 02 | FT | 470 pF | ±20% | 300V | 100V | — | — | 2 | 8 | 14 | 20 | 28 | 34 |
| 03 | FT | 820 pF | ±20% | 300V | 100V | — | 2 | 6 | 13 | 19 | 25 | 33 | 39 |
| 04 | FT | 1500 pF | ±20% | 300V | 100V | — | 5 | 10 | 18 | 24 | 30 | 38 | 44 |
| 05 | FT | 4700 pF | ±20% | 300V | 100V | 8 | 14 | 20 | 28 | 34 | 40 | 48 | 54 |

Standard Performance

| Filter Designation | Type | Capacitance | | Dielectric Withstanding Voltage | Working Voltage DC -55°C to +125°C | Minimum Insertion Loss - Decibels (dB) 50 ohm system per MIL-STD-220 (no load) | | | | | | | |
|--------------------|------|-------------|-----------|---------------------------------|------------------------------------|--|--------|--------|--------|---------|---------|---------|-------|
| | | Value | Tolerance | | | 5 MHz | 10 MHz | 20 MHz | 50 MHz | 100 MHz | 200 MHz | 500 MHz | 1 GHz |
| 10 | COB | 100 pF | ±20% | 300V | 100V | — | — | — | — | 1 | 6 | 14 | 20 |
| 11 | COB | 470 pF | ±20% | 300V | 100V | — | — | 2 | 8 | 14 | 20 | 28 | 32 |
| 12 | COB | 820 pF | ±20% | 300V | 100V | — | 2 | 6 | 13 | 19 | 25 | 32 | 32 |
| 13 | COB | 1500 pF | ±20% | 300V | 100V | — | 5 | 10 | 18 | 24 | 30 | 32 | 32 |
| 14 | COB | 4700 pF | ±20% | 300V | 100V | 8 | 14 | 20 | 28 | 32 | 32 | 32 | 32 |

Right Angle PCB

Receptacle

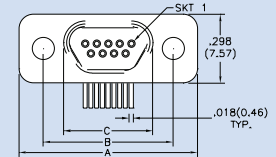
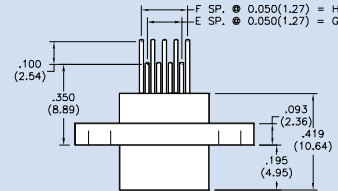
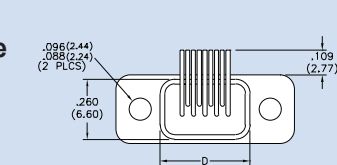

Plug

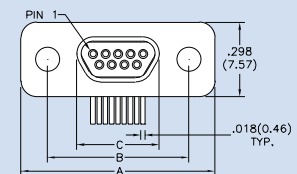
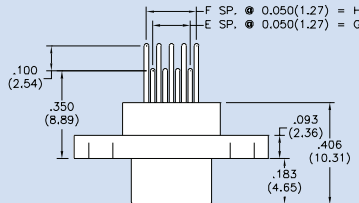
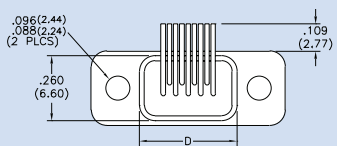

| Size | A | B | C (RCPT) | C (Plug) | D | E | F | G | H |
|------|---------------|---------------|---------------|---------------|---------------|----|----|--------------|--------------|
| 9 | .775 (19.69) | .565 (14.35) | .388 (9.86) | .330 (8.38) | .390 (9.91) | 4 | 5 | .200 (5.08) | .250 (6.35) |
| 15 | .925 (23.50) | .715 (18.16) | .538 (13.67) | .480 (12.19) | .540 (13.72) | 7 | 8 | .350 (8.89) | .400 (10.16) |
| 21 | 1.075 (27.31) | .865 (21.97) | .688 (17.48) | .630 (16.00) | .690 (17.53) | 10 | 11 | .500 (12.70) | .550 (13.97) |
| 25 | 1.175 (29.85) | .965 (24.51) | .788 (20.02) | .730 (18.54) | .790 (20.07) | 12 | 13 | .600 (15.24) | .650 (16.51) |
| 31 | 1.325 (33.66) | 1.115 (28.32) | .938 (23.83) | .880 (22.35) | .940 (23.88) | 15 | 16 | .750 (19.05) | .800 (20.32) |
| 37 | 1.475 (37.47) | 1.265 (32.13) | 1.088 (27.64) | 1.030 (26.16) | 1.090 (27.69) | 18 | 19 | .900 (22.86) | .950 (24.13) |

Dimensions in inches (mm)

Micro D Series Filtered Connectors

| Size | A | B | C (RCPT) | C (Plug) | D |
|-----------|------------------|------------------|------------------|------------------|------------------|
| 9 | .775 (19.69) | .565 (14.35) | .388 (9.86) | .330 (8.38) | .390 (9.91) |
| 15 | .925 (23.50) | .715 (18.16) | .538 (13.67) | .480 (12.19) | .540 (13.72) |
| 21 | 1.075 (27.31) | .865 (21.97) | .688 (17.48) | .630 (16.00) | .690 (17.53) |
| 25 | 1.175 (29.85) | .965 (24.51) | .788 (20.02) | .730 (18.54) | .790 (20.07) |
| 31 | 1.325 (33.66) | 1.115 (28.32) | .938 (23.83) | .880 (22.35) | .940 (23.88) |
| 37 | 1.475 (37.47) | 1.265 (32.13) | 1.088 (27.64) | 1.030 (26.16) | 1.090 (27.69) |

Dimensions in inches (mm)

Vertical PCB

Receptacle

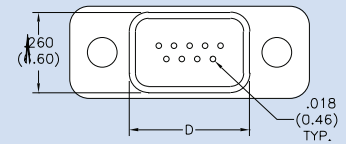

Plug

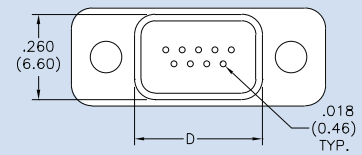
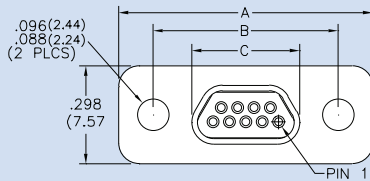

Solder Cup

Receptacle

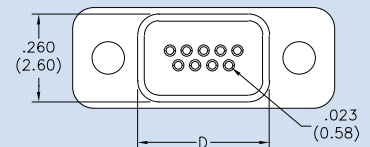
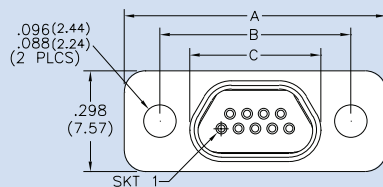

Plug

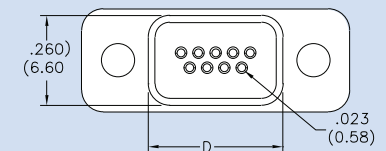

Micro D Series Filtered Connectors Options

JP - #2-56 Jack Post M83513/05-07



JS - #2-56 Jack Screw M83513/05-05



TI - Threaded Insert Receptacle



TI - Threaded Insert Plug



GB - Ground Bracket Receptacle



GB - Ground Bracket Plug



Micro D Series Filtered Connectors Board and Panel Cutouts

Vertical PCB Layouts

Pin Connector Shown

9 Contacts



15 Contacts



21 Contacts



25 Contacts



31 Contacts

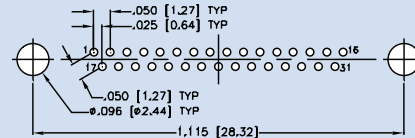

37 Contacts



Right Angle PCB Layouts

Pin Connector Shown

9 Contacts

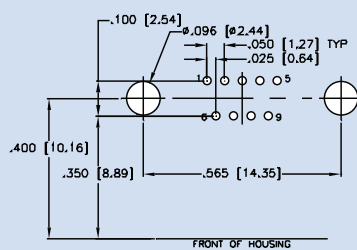

15 Contacts

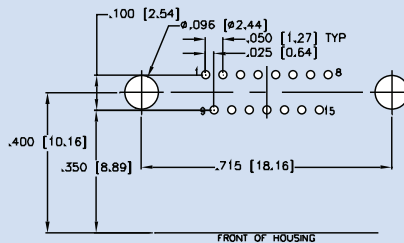

21 Contacts

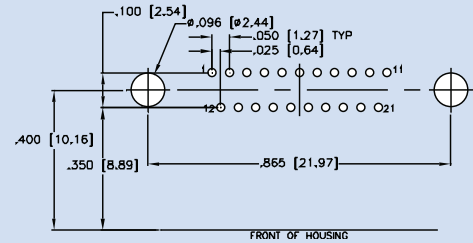

25 Contacts

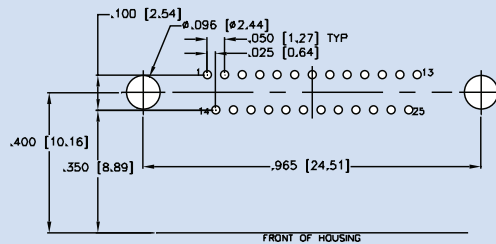

31 Contacts



37 Contacts



Notes: PC Tail Diameter 0.018 ±0.002 (0.46 ±0.05) Contact numbers shown are pin connector.
Reverse for socket. Patterns shown are for connector mounting side of PC board.

Filtered Miniature Ribbon Connectors

Filtered miniature ribbon connectors are fully intermateable and interchangeable with existing standard product. Rugged design construction and predictable capacitive filter performance is available in right-angle and male/female adapter versions.

Applications for this type of connector are widely diversified and include all phases of the telecommunications industry including original telephone manufacturing, operating telephone companies, cable reclamation, cable manufacturing and bay connectorization. The filtered miniature ribbon connector line is also ideally suited for use in printers, computer terminals, test equipment, business and copying machines, telemetering, and various equipment used in the security industry.

Features

- Lower installed cost
- Assists with FCC Part 15; available for Part 68 requirements
- Applicable for VDE specifications 0871, 0875-0878, Vfg Federal Regulations and VCCI noise requirements
- Drop-in replacement, matched footprint
- All circuit lines filtered
- Connector body is recognized under the Component Recognition Program of Underwriters Laboratories, Inc.
- Plastic components are UL94V-0 rated
- Connector body is certified by Canadian Standard Association

Mechanical Specifications - Adapter

Shell Zinc
 Thermoplastic
 Insert Black, high strength
 Contacts Copper alloy
 Contact Plating 30uin (.76um) (min.)
 gold over nickel

Mechanical Specifications - Connector

Shell Steel, tin plated
 Thermoplastic
 Insert Blue, 30% glass filled
 Contacts Phosphor bronze
 Contact Plating Gold flash (<10 μ in) over nickel

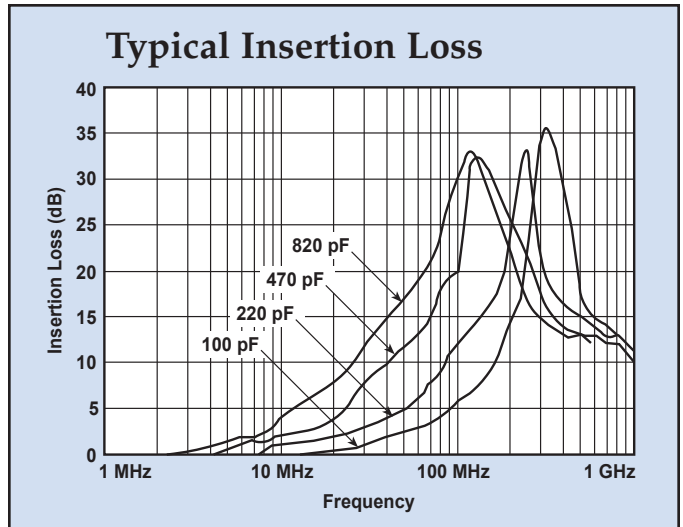
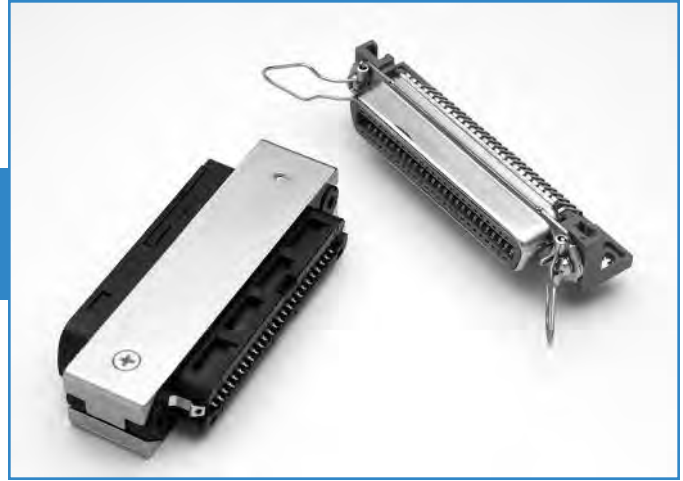

Electrical Specifications

Operating Temperature -55°C - 105°C
 Dielectric Withstanding Voltage 1000 VAC min per (FCC Part 68 test)
 Capacitance 100 pF, 220 pF, 470 pF, 820 pF, ±15% (adapter), ±20% (connector)
 Dissipation Factor 2.5% max (adapter) 5% max (connector)

Filtered Miniature Ribbon Connectors 50 Position

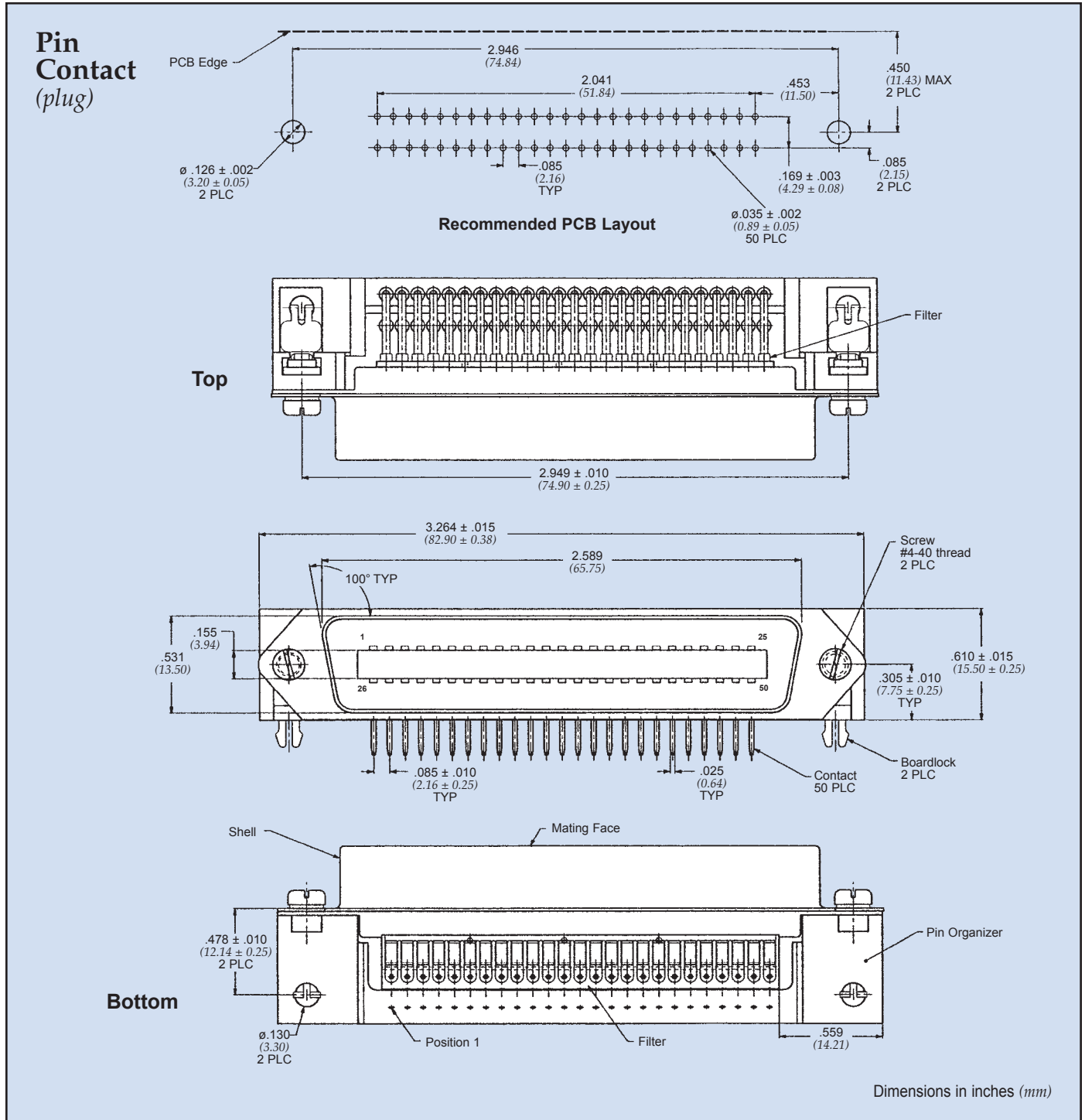

| Part Number | Capacitance Value |
|-------------|--------------------|
| 56-882-002 | 100 pF, $\pm 20\%$ |
| 56-882-003 | 220 pF, $\pm 20\%$ |
| 56-882-004 | 470 pF, $\pm 20\%$ |
| 56-882-005 | 820 pF, $\pm 20\%$ |

Filtered Miniature Ribbon Connectors 50 Position

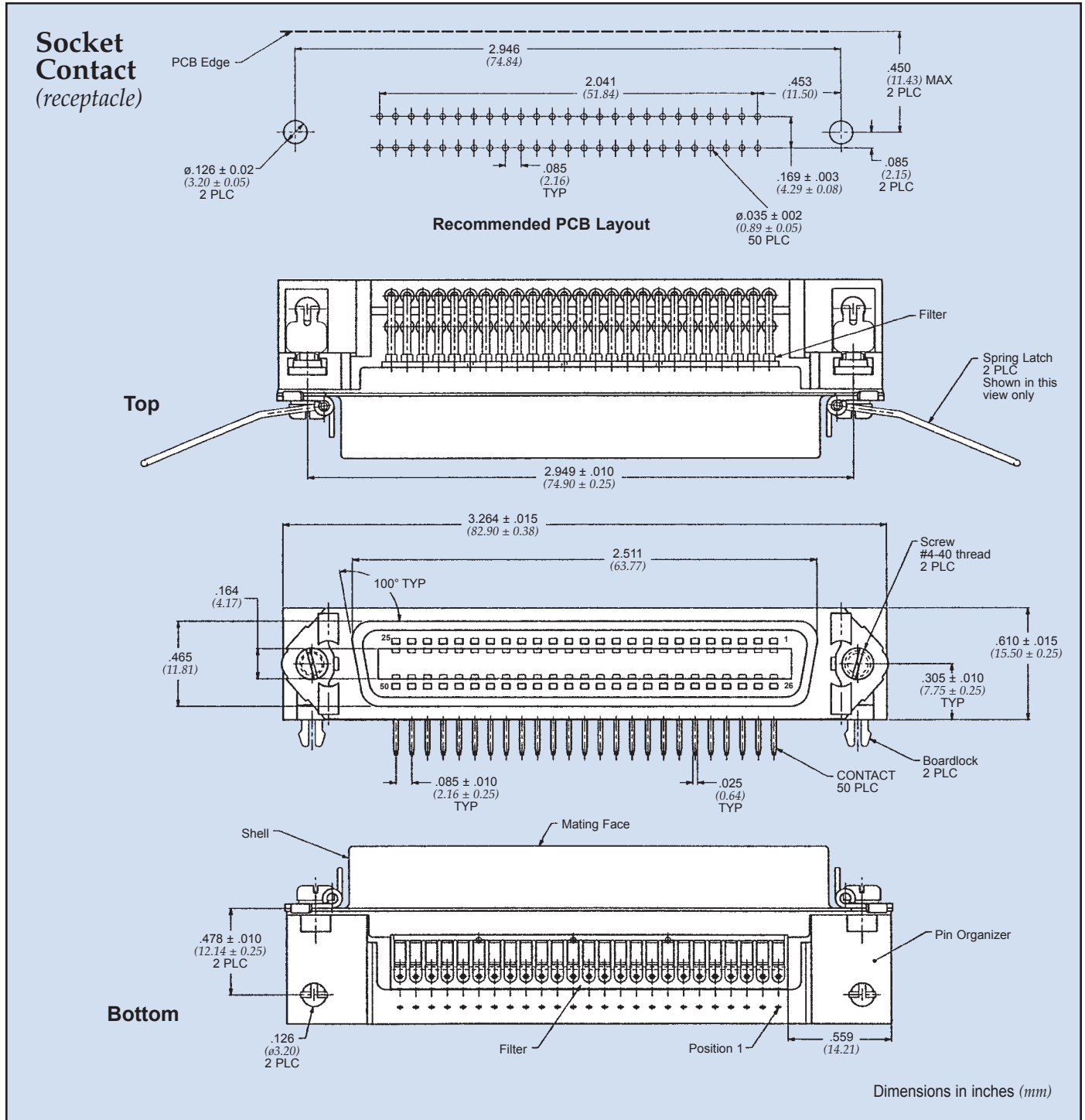

| Part Number | Capacitance Value |
|-------------|-------------------|
| 56-886-002 | 100 pF, ±20% |
| 56-886-003 | 220 pF, ±20% |
| 56-886-004 | 470 pF, ±20% |
| 56-886-005 | 820 pF, ±20% |

Filtered Miniature Ribbon Connectors 50 Position

Adapter

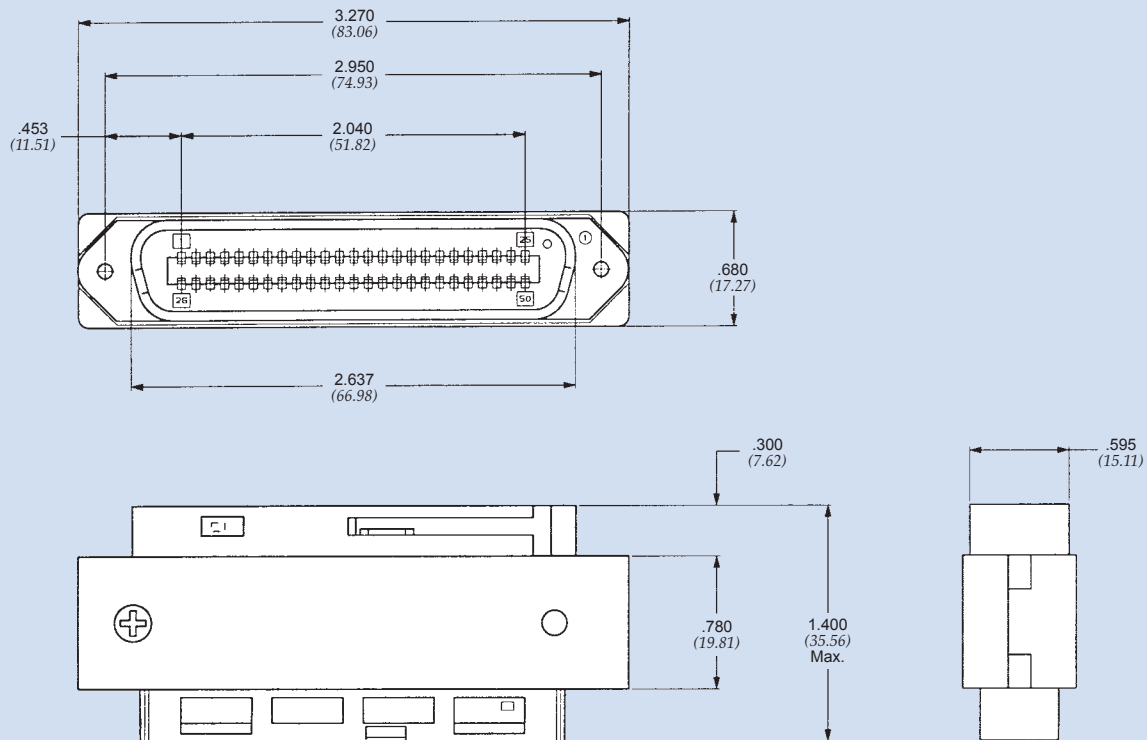

Dimensions in inches (mm)

| Part Number | Capacitance Value |
|-------------|-------------------|
| 56-889-002 | 100 pF ±15% |
| 56-889-003 | 220 pF ±15% |
| 56-889-004 | 470 pF ±15% |
| 56-889-005 | 820 pF ±15% |

Hardware options also available. Consult factory for more information.

Filtered Modular Jack Connectors

Protecting signals from electromagnetic interference (EMI) is now more important than ever. API's Spectrum Control brand gives you more choices in keeping your signals clean and free of EMI. Whatever the level of protection your application requires, we offer signal conditioning products that meet varied levels of price and performance.

These compact, low-cost, filtered printed circuit board RJ45 modular jack connectors from API's Spectrum Control brand offers an inexpensive way to protect equipment from conducted and radiated electromagnetic interference (EMI), while meeting all appropriate performance requirements. Offering compact size and high reliability, these new connectors are fully intermateable and interchangeable with existing standard products. The low profile and narrow width of the multi-port style allows more ports to be packed into less space.

Filtered versions can be supplied in shielded or unshielded versions. Redundant shielding tabs ensure that a low impedance ground path is maintained across the interface. These flame retardant polyester thermoplastic connectors are compatible with wave solder environments, and utilize duplex plated contacts with solder tails.

Modular jack connectors assist with FCC Part 15 A & B; and CISPR 22 compliance.

Applications for this type of connector are widely diversified and include: LANs, WANs, network cards, broadband transmission equipment, workstations, peripherals, fax/modems, copy machines and multiplexing.

Features

- RoHS compliant
- Lower installed cost
- Assists with FCC Part 15 A & B; and CISPR 22 compliance
- Drop-in replacement, matched footprint
- All circuit lines protected
- Inductor, capacitor or ESD versions
- Unshielded or shielded versions
- Select lead versions available
- High temperature versions available for reflow processes

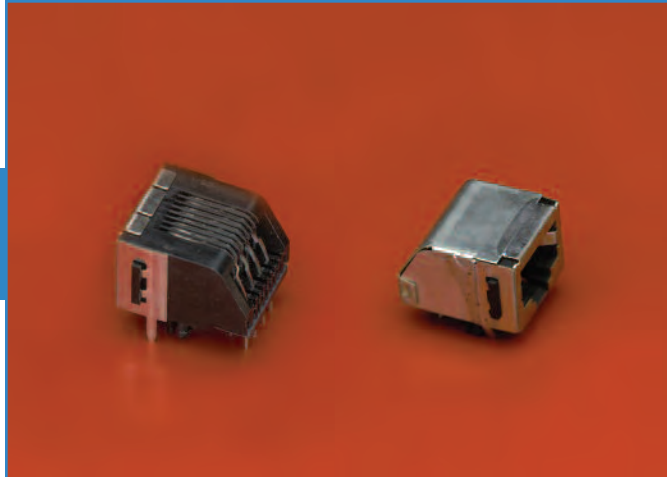

Typical Impedance vs. Frequency (Ferrite Version)

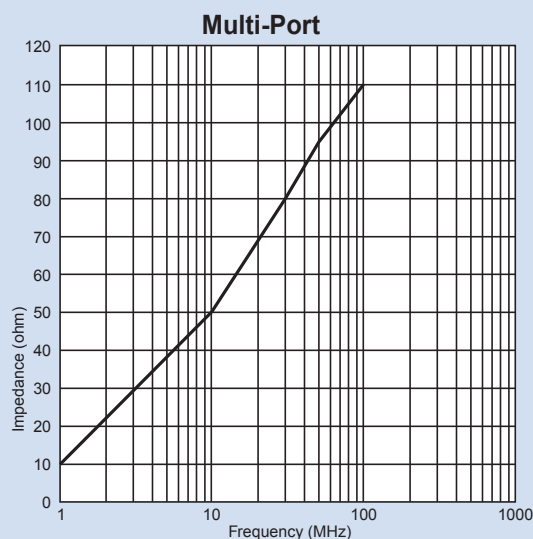
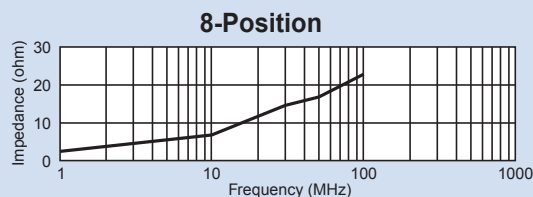

Typical Time Voltage Curves (ESD Version)

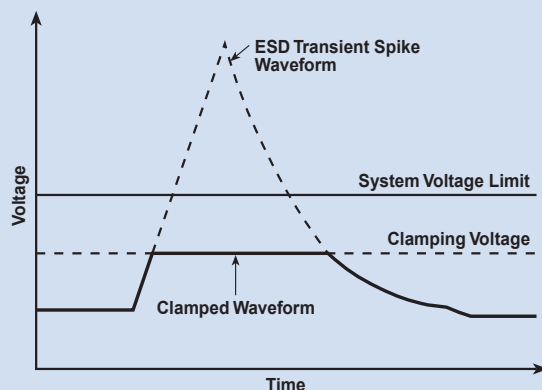

Typical Time-Voltage Curve of Transient Spike on Integrated Protected Connector with Capacitance (Parts with Working Voltage Code starting with 0)

Rugged USB Connectors

New rugged USB Connectors from API's Spectrum Control brand feature a heavy-duty design able to connect to USB 2.0 or 1.1 ports, making them ideal for demanding, high stress applications.

Product Highlights

- Connectors meet seal requirements of IEC-60529, Code IP67 on PCB side
- Meet immersion requirements per MIL-STD-810F, Method 512.4 to 20 meters (unmated)
- RoHS compliant
- Supplied with gasket
- Ideal for demanding applications in the military, communications, medical, industrial and computing industries
- Type A, right-angle mounted connector
- USB 2.0 or 1.1 applications
- Part Number: 56FU04-017



Electrical Specifications

Operating Temperature . . . -40°C to +105°C

Current Rating 1.5 Amps

Contact Resistance 30 mΩ

Dimensions

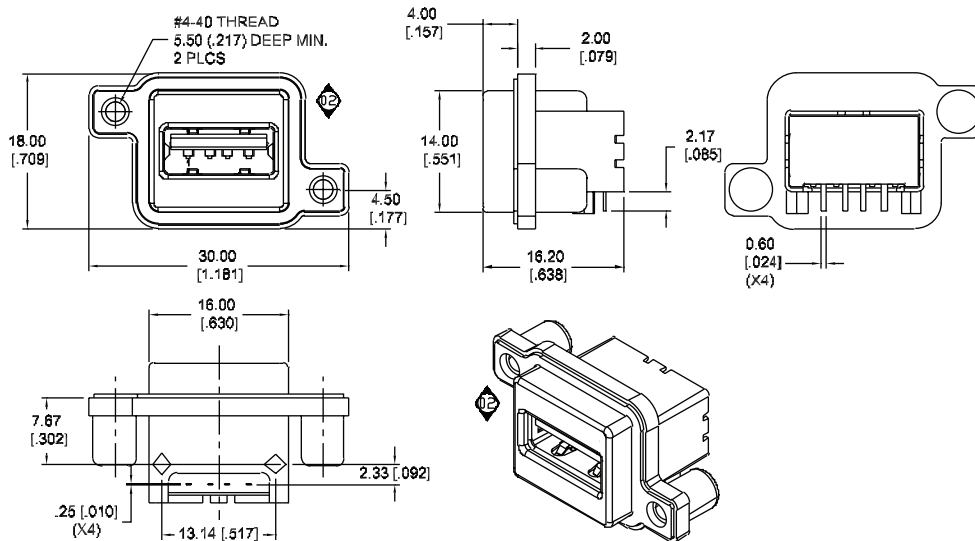

Hooded Strain Reliefs

Hooded strain reliefs are used whenever a connector is used on a cable assembly which will be exposed to users and subject to multiple disconnects. Hoods are designed to protect users from shock hazard by exposed solder joints, as well as provide a strain relief for the wires and protection against accidental short circuits.

Since most filter connectors are larger than standard connectors, there had been a problem fitting most commercially available hoods. Spectrum Control solves this problem. Our hoods are molded of thin wall plastic, providing extra internal space to accommodate larger filter connectors. The hood is constructed of extremely durable polycarbonate and meets the flammability requirements for UL94V-0.

In addition, hoods are ideal for use on applications which require the use of extra components such as resistors or varistors on the wires. The nonconductive hood conveniently houses the connector, components, and protects any joints.

- **2560-9000-XX** is supplied with metal retention clips to hold the connector within the hood assembly. This item is recommended for use with Spectrum Filtered D-sub's, most other filtered D-sub's, and most standard D-sub's.
- **2560-9001-XX** is meant to be used with a connector which has a special eyelet on the mounting flange. This feature is available as an option on the Spectrum Filtered D-sub. Contact factory for additional information.

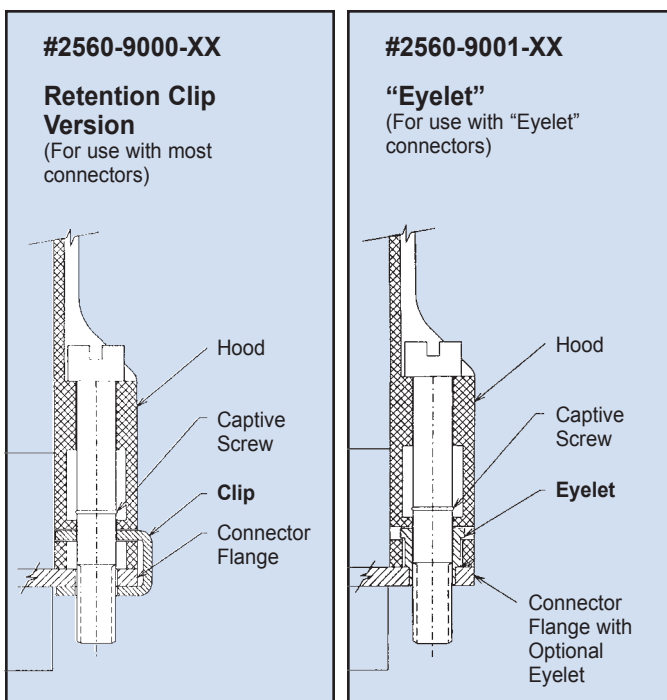

Ordering Information and Dimensions

| Part Number | Connector Size | A ±.005 | B Max | C Max | D Max | E Max | F Max |
|------------------------------|----------------|------------------|------------------|------------------|------------------|-----------------|-----------------|
| 2560-9000-01 2560-9001-01 | 9 | 0.984 (24.99) | 1.228 (31.19) | 1.710 (43.43) | 0.985 (25.02) | .685 (17.40) | .240 (6.07) |
| 2560-9000-02 2560-9001-02 | 15 | 1.312 (33.33) | 1.556 (39.52) | 1.710 (43.43) | 1.310 (26.71) | .685 (17.40) | .300 (7.62) |
| 2560-9000-03 2560-9001-03 | 25 | 1.852 (47.04) | 2.103 (53.42) | 1.710 (43.43) | 1.850 (46.99) | .685 (17.40) | .400 (10.16) |
| 2560-9000-04 2560-9001-04 | 37 | 2.500 (63.50) | 2.744 (69.70) | 1.710 (43.43) | 2.500 (63.50) | .685 (17.40) | .400 (10.16) |

Dimensions in inches (mm)

Custom Engineered Solutions

Despite the breadth of our filtered connector product line, there exist certain applications which demand a custom EMC solution. Our engineering staff will work with your design team to provide a custom filtered connector which meets your individual requirements. Examples of custom projects are shown below.

Special Mounting Flanges

- Housings can be designed to be integrated into the customer's equipment. The housings are constructed of machined materials, or precision diecast zinc.

Value-added Assemblies

- API's capabilities extend beyond just supplying filter connectors. Additional operations such as sourcing and assembling flexible circuits, adding flying leads, or making connector to connector assemblies, all can be provided in conjunction with the filter connector.

Custom Filter Arrangements

- Complex filters involving unbalanced Pi types, LC types with large inductive components, special pin-in to pin-out translations, and overvoltage protective devices such as diodes and varistors can be packaged within the connector.

Other Connector Formats

- Manufacturer specific connectors also can be filtered. Our involvement ranges from complete design to implementing minor modifications to include the addition of the filter components. Medical equipment and hand-held devices are examples of excellent applications for these connectors.

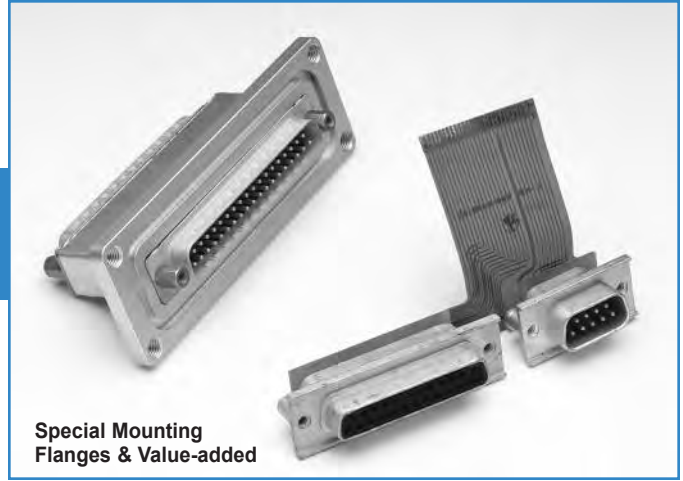

Special Mounting Flanges & Value-added



Custom Filter Arrangements & Connectors

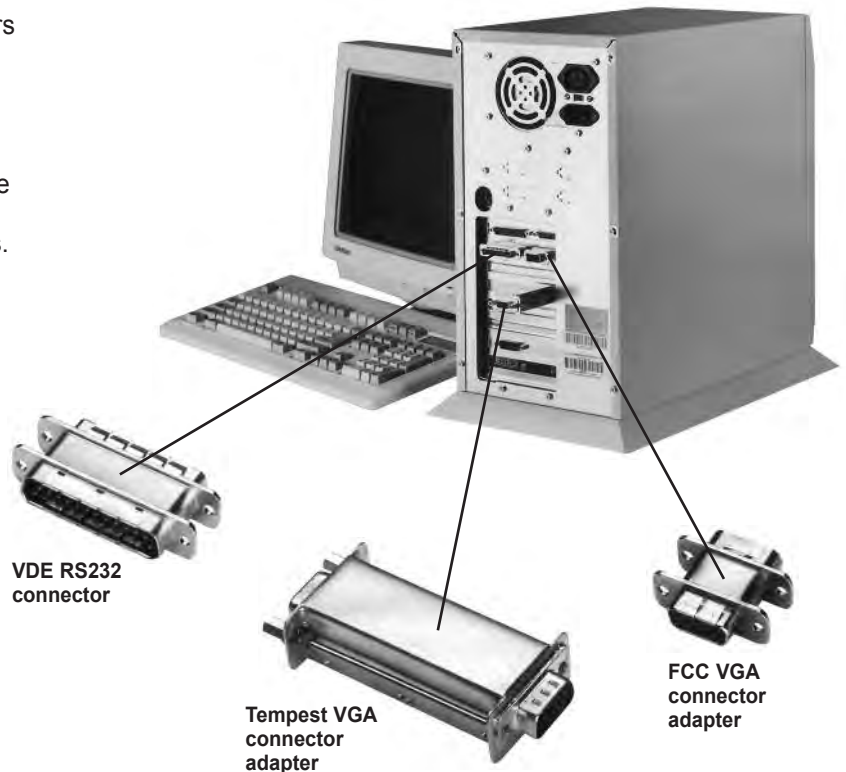

VDE RS232 connector

Tempest VGA connector adapter

FCC VGA connector adapter

Filtered Connector Performance Specifications

The filtered D-subminiature connectors shown in this catalog have been designed and tested to the following test plan.

The information shown can be used as a basis for your filtered connector specifications. (Contact API for additional details.)

| Test Group | Order of Test | Examination of Test | Test Method | Post Test Requirements |
|------------|---|---|---|---|
| I | 1 | Visual and Mechanical Examination | | In accordance with applicable requirements. |
| | 2 | Materials, Designs Construction and Workmanship | | |
| | 3 | Physical Dimensions and Marking | | |
| | 4 | Capacitance | MIL-STD-202 Method 305 1 KHz, 1VRMS max. 25°C | Within specified tolerance. |
| | 5 | Dielectric Withstanding Voltage | MIL-STD-202 Method 301 | No breakdown or damage. |
| | 6 | Insulation Resistance | MIL-STD-202 Method 302, test condition at rated voltage | 5000 megohm minimum. |
| | 7 | Insertion Loss | MIL-STD-220 No load | In accordance with applicable requirements. |
| II | 1 | Contact Engagement and Separation | MIL-C-24308, Para. 3.5.10 | Maximum engagement force 18.0 oz., minimum separation force 0.7 oz. |
| | 2 | Mating and Unmating Force | MIL-C-24308, Para. 3.5.4 | MIL-C-24308, Para. 3.5.4 Table II Limits: Shell size 1-5, class G only. |
| | 3 | Durability | MIL-C-24308, Para. 3.5.16, 4.7.18, except 100 cycles | MIL-C-24308, Para. 3.5.9 Contact resistance at 1 amp. 20 millohms max. |
| | 4 | Thermal Shock | MIL-STD-202 Method 107, Test condition B, -55°C to +125°C | No evidence of damage. Insulation resistance not less than 2500 megohms. |
| | 5 | Solderability | MIL-STD-202; Method 208, RMA-Flux | Terminals shall meet solderability requirements. |
| | 6 | Moisture Resistance | MIL-STD-202 Method 106, less step seven | Insulation resistance not less than 500 megohms. Meet dielectric withstanding voltage requirements. |
| | 7 | Resistance to Soldering Heat | MIL-STD-202 Method 210, Test condition D | Insulation resistance not less than 500 megohms. Meet dielectric withstanding voltage requirements. |
| III | 1 | Vibration | MIL-STD-202 Method 204, Test condition D, 100 mA, current | No interruption of current flow longer than 1 microsecond. Insulation resistance greater than 5000 megohms. |
| | 2 | Shock | MIL-STD-202 Method 213. Test Condition G, 100 mA, current | No interruptions of current flow longer than 1 microsecond. |
| | | | | Contact resistance at 1 amp. 15 millohms max. |
| | | | | Capacitance within specified limits. |
| 3 | Mounting Inserts a. Prevailing torque (locking) b. Installation torque (locking) c. Push-out Force | IFI-100 | a. 3 inch-pounds max. b. 6 inch-pounds without damage c. 10 pounds axial force without loosening insert | |
| IV | 1 | Life | MIL-STD-202 Method 108, Test condition D, within 125% of rated voltage at the maximum operating temperature. | Filter shall meet all initial requirements except insulation resistance shall not be less than 500 megohms. |

Board & Panel Cutouts

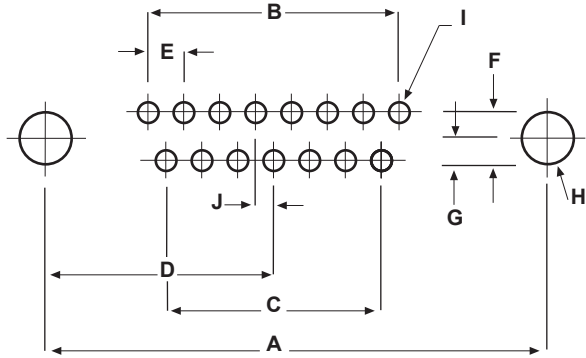

Printed Circuit
Vertical Board Mount (standard density)

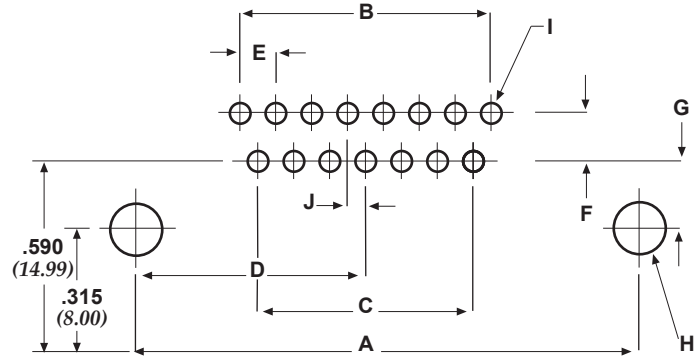

Printed Circuit
Right Angle Mount (standard density)

Board Layout (Pin and Socket Contact) for Standard D-Sub Connectors

| Shell Size | A | B | C | D | E | F | G | H | I (Dia.) | J |
|------------|------------------|---|--|------------------|----------------|----------------|--------------------------------------|----------------|----------------|----------------|
| 9 (0) | .984 (25.00) | .436 = 4 x .109 (11.07) (2.77) | .327 = 3 x .109 (8.31) (2.77) | .492 (12.50) | | | PCB Mount .056 (1.42) | | | |
| 15 (1) | 1.312 (33.32) | .763 = 7 x .109 (19.38) (2.77) | .654 = 6 x .109 (16.61) (2.77) | .656 (16.66) | | | PCB Mount Rt Angle .275 (6.99) | .125 (3.18) | .045 (1.14) | .054 (1.37) |
| 25 (2) | 1.852 (47.04) | 1.308 = 12 x .109 (33.22) (2.77) | 1.199 = 11 x .109 (30.45) (2.77) | .926 (23.52) | .109 (2.77) | .112 (2.84) | 0.112 2 rows | | | |
| 37 (3) | 2.500 (63.50) | 1.962 = 18 x .109 (49.83) (2.77) | 1.853 = 17 x .109 (47.07) (2.77) | 1.250 (31.75) | | | | | | |
| 50 (4) | 2.406 (61.11) | 1.744 = 16 x .109 (44.30) (2.77) 2 rows | 1.635 = 15 x .109 (41.35) (2.77) 1 row | 1.203 (30.56) | | | 0.00 1 row | | | |

Panel Cutouts (Front or Rear Mounting) for Standard and High-Density D-Sub Connectors

| Shell Size | A ±.015 (.38) | B ±.015 (.38) | C ±.015 (.38) | D ±.015 (.38) | E ±.003 (.08) | F ±.005 (.13) | G ±.002 (.05) | Diagram |
|------------|---------------------|---------------------|---------------------|---------------------|---------------------|---------------------|---------------------|---------|
| 9 (0) | .984 (24.99) | .492 (12.49) | .777 (19.74) | .388 (9.87) | .440 (11.18) | .220 (5.59) | .150 (3.81) | |
| 15 (1) | 1.312 (33.32) | .656 (16.66) | 1.105 (28.07) | .552 (14.03) | .440 (11.18) | .220 (5.59) | .150 (3.81) | |
| 25 (2) | 1.852 (47.04) | .926 (23.52) | 1.645 (41.78) | .822 (20.89) | .440 (11.18) | .220 (5.59) | .150 (3.81) | |
| 37 (3) | 2.500 (63.50) | 1.250 (31.75) | 2.293 (58.24) | 1.146 (29.12) | .440 (11.18) | .220 (5.59) | .150 (3.81) | |
| 50 (4) | 2.406 (61.11) | 1.203 (30.55) | 2.190 (55.63) | 1.095 (27.81) | .550 (13.97) | .275 (6.98) | .150 (3.81) | |

Dimensions in inches (mm)

Board & Panel Cutouts

15 High-Density Pin/PCB

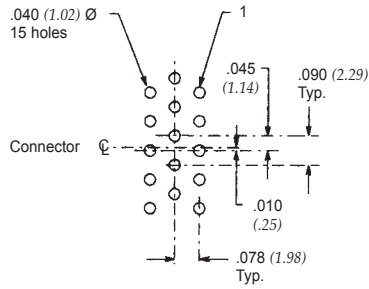

15 High-Density Socket/Right Angle

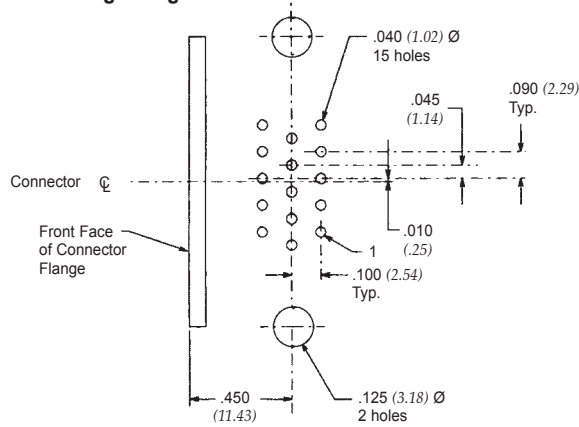

26 High-Density Pin/PCB

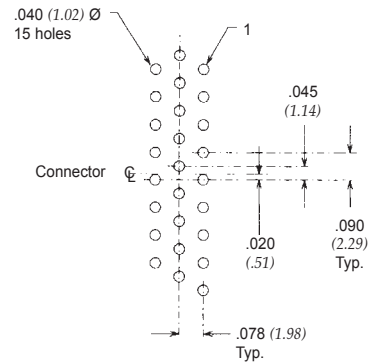

26 High-Density Socket/PCB

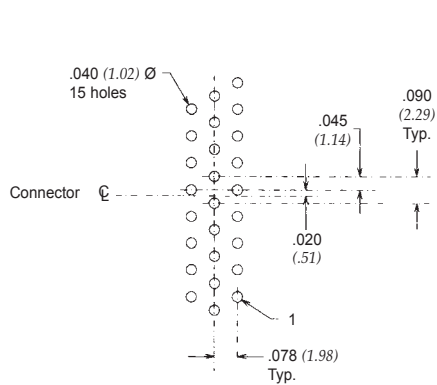

44 High-Density Pin/PCB

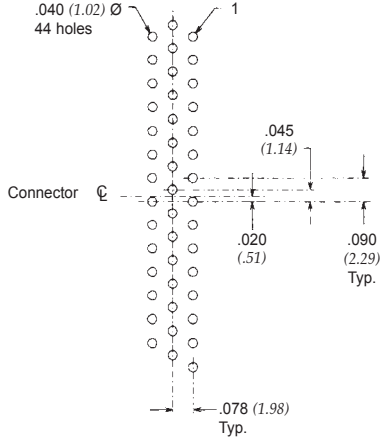

44 High-Density Socket/PCB

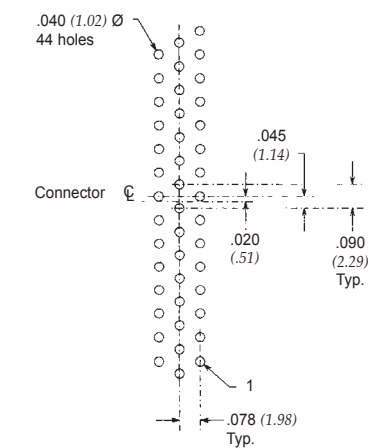

62 High-Density Pin/PCB

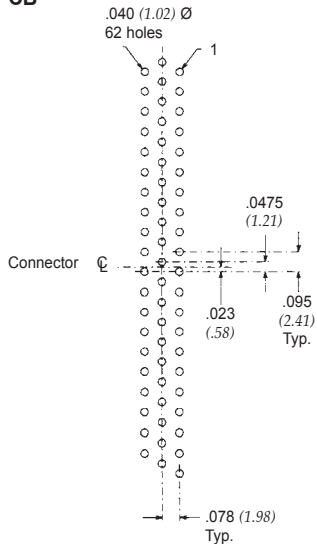

62 High-Density Socket/PCB

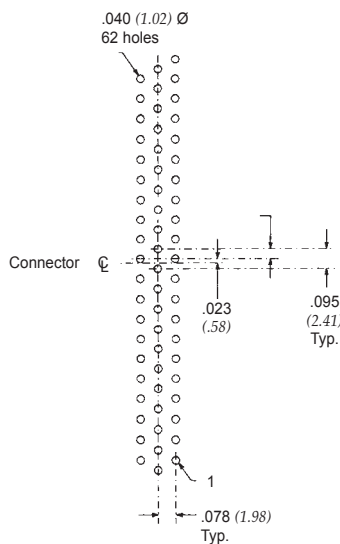

78 High-Density Socket/PCB Pin/PCB

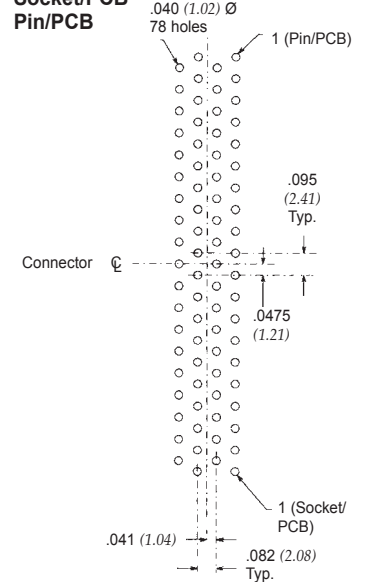

Dimensions in inches (mm)

Quietshield™ Gaskets & Shielding

flexible, conformable and lightweight Quietshield™ products deliver effective EMI shielding across seams or gaps within an enclosure

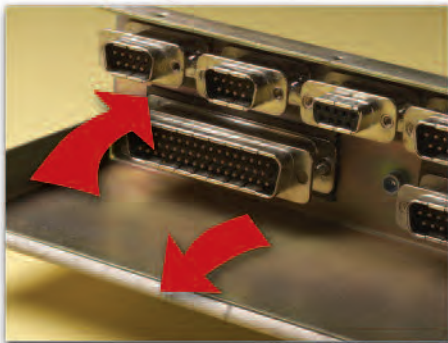

Fabric-Over-Foam Gaskets are low cost, soft and easy to apply. These gaskets are available in a variety of materials and profiles, including rectangular, "D" shaped, FL shaped and DD shaped... **FC68-FC69**

Waved Metal and Fabric-Over-Foam I/O Gaskets are flat products used to provide a ground contact between a metal connector and the electronic enclosure or mating connector... **FC70**

Shielding Tapes and Fabrics are flexible, lightweight, and easy-to-install shielding materials offering high conductivity with a low electrical resistance and are available in a variety of fabric styles... **FC71**

Wire Mesh Gaskets are available as all mesh or elastomer core mesh gaskets. They provide excellent heat and corrosion resistance and are used between two surfaces to maintain electrical continuity while shielding electromagnetic waves... **FC72**

Conductive Silicone is used for its heat resistant properties and can be produced in many different forms such as sheets, molded parts, die-cuts or strips. These conductive elastomers are water resistant, can eliminate static electricity, and act as an absorber at high frequencies... **FC73**

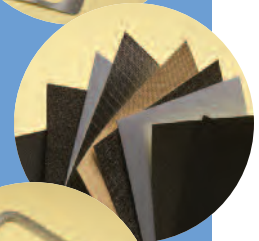
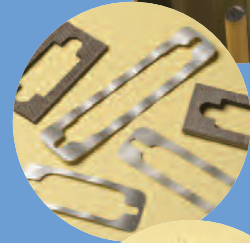
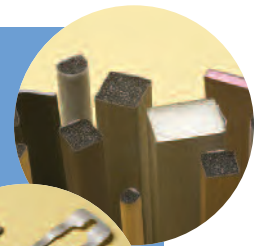

Shielding Theory and Introduction

Shielding Theory

Electromagnetic shielding is used to prevent electromagnetic signals such as radio signals from leaving or entering a box or enclosure. Signals inadvertently emitted by an electronic device can cause distortion or interruption in normal radio communications in a localized area. This is the basis of most laws and regulations concerning electromagnetic interference. In addition, normal radio signals can cause unprotected electronic devices to malfunction. Depending on the device's function, a malfunction in the device could be a minor inconvenience such as static on a radio, or life threatening such as the malfunction of a life support system at a hospital.

Introduction

The electromagnetic shield in most cases is the electronic housing itself. The housing/shield forms a metal cage around the electronic circuits in a device. Most of the electromagnetic signal is absorbed with a small portion (3 to 10 dB) of the signal reflected off the metal housing. Most of the absorbed signal creates alternating currents at radio frequencies which travels on the surface of metal. This allows the electromagnetic shield to keep signals from outside the enclosure on the outside of the shield and signals from inside signals on the inside of the shield.

The shield will continue to function as long as there are no holes in the electromagnetic shield which would allow the currents to flow from one side of the shield to the other. Holes are a necessity in an electronic enclosure. Connectors, wires, and cables are needed to transmit information to and from electronic devices. Doors and covers are needed to get access to components to maintenance, service, and keypads may also be required. The problem is that all of these items cause openings in the shield which reduce the performance of the shield.

Special devices such as shielding gaskets, shielding ventilation panels, shielded filtered connectors, and shielded switches minimize the effect of a hole in the shield.

The length of the hole and wavelength of the signal that needs to be shielded are the major factors determining the shielding effectiveness of an electronic enclosure. The distance between spotwelds, or screws which hold a metal housing together count as long narrow holes. Higher frequencies (lower wavelengths) flow more easily through smaller holes, and so the highest frequency needed to be shielded is the frequency of concern when designing shielding.

Aperture versus frequency charts can give a rough estimate of the shielding effectiveness of a metallic electronic housing.

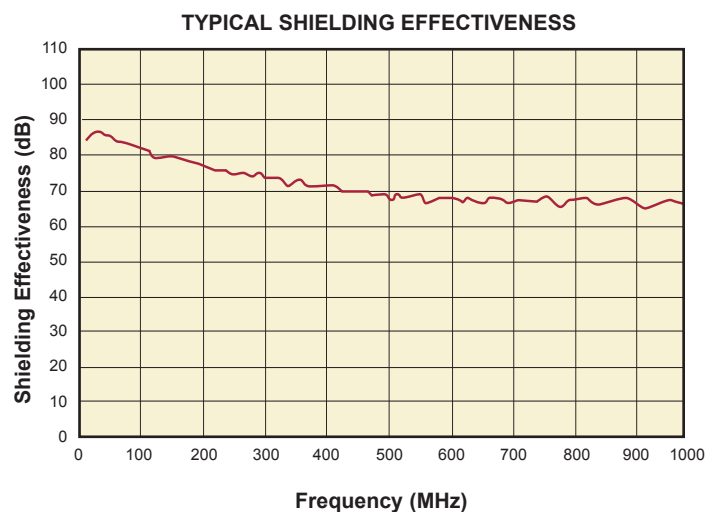
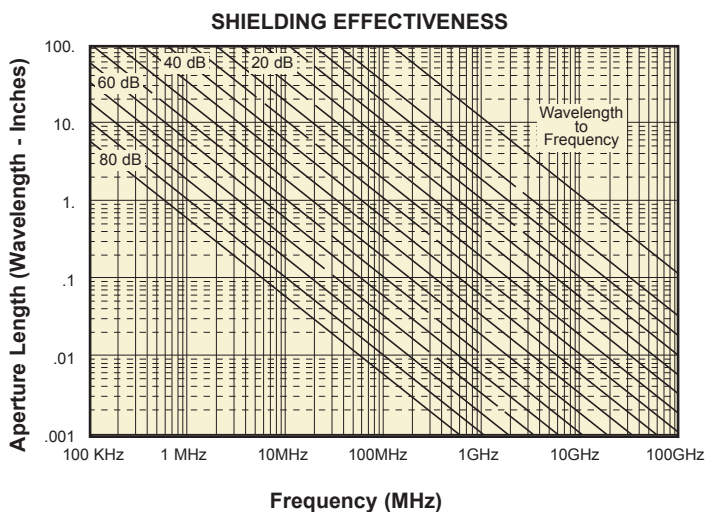

Test Methods: ASTM D-4935-89
Test Fixture: Flanged coaxial transmission line

Quietshield™ Part Number System

Example: **57D1211205 - 7200**

The part number shown represents a gasket with woven foam made of neoprene, conductive PSA.
The gasket has copper-nickel plating that is 0.120" wide x 0.050" thick x 72" long.

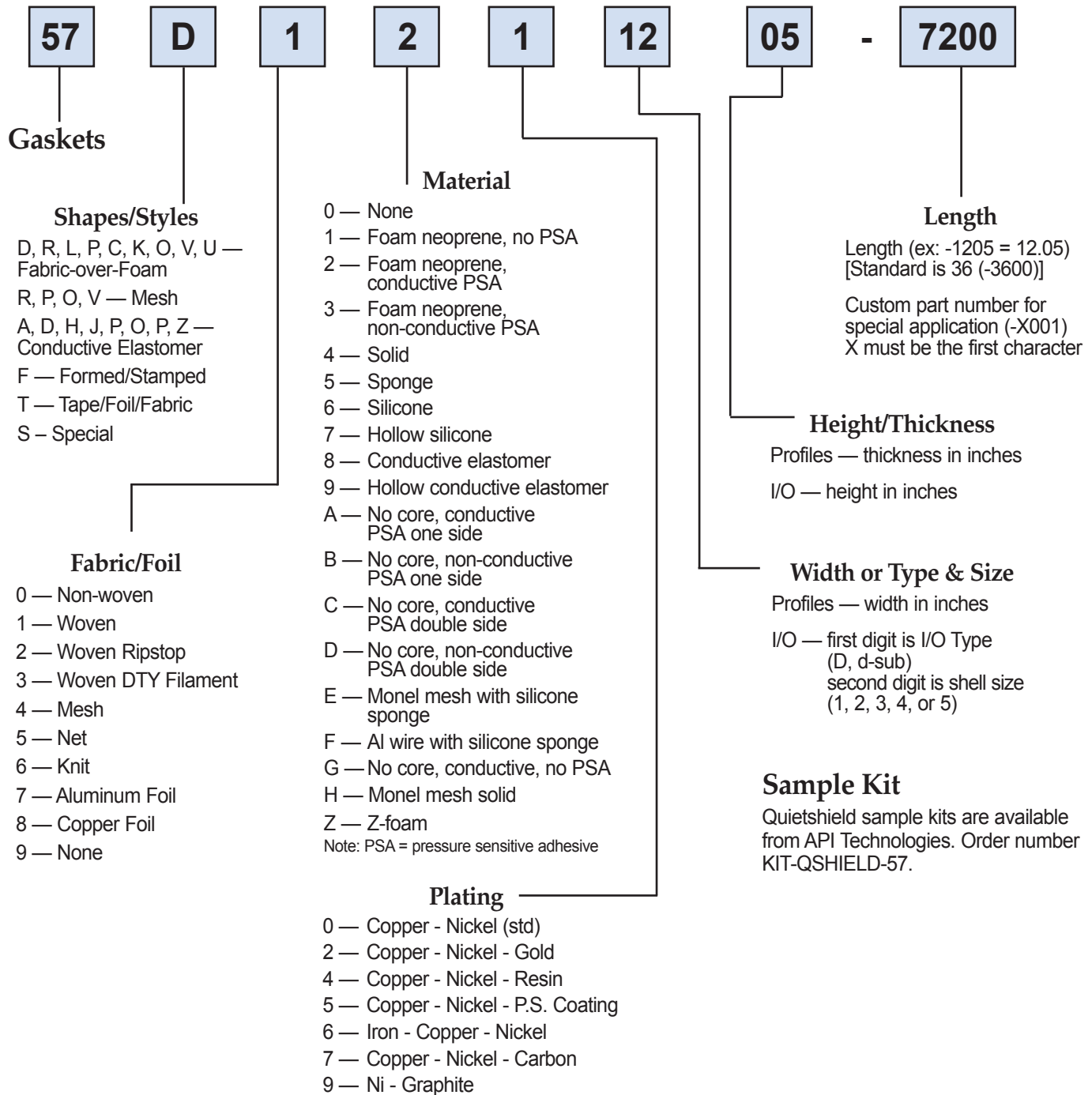

Sample Kit

Quietshield sample kits are available from API Technologies. Order number KIT-QSHIELD-57.

Quietshield™ Fabric-over-Foam Gaskets

Features

- Maintain shielding effectiveness across seams or gaps
- Shielding Effectiveness (SE) of 70 - 100 dB between 1 MHz to 18 GHz
- Flexible and conformable
- No creasing or tearing
- Lightweight material

Profile Gaskets

Quietshield™ EMI/RFI Gaskets maintain shielding effectiveness (SE) across a seam or gap in the electronic equipment's shielding material.

Quietshield gaskets provide unique solutions to your most stringent shielding, grounding, ESD and packaging requirements. It's the cost-effective avenue for creativity in design. These gaskets consist of polyurethane foam combined with highly conductive fabrics. Specially designed polyurethane foam is soft, resilient and provides the perfect fit. Our gaskets are made with seven different types of fabric plating and two types of thermal adhesive, standard or flame retardant. Our flame retardant adhesive complies with UL94VTM-1 and VTM-0. If necessary, the polyurethane foam core can also be plated with Cu and Ni to provide additional conductivity.

Fabric-over-Foam Gaskets, unlike elastomer or finger strip gaskets, provide softness for easy application with a variety of materials and designs at low cost. The best quality with high conductivity, low electrical resistance and minimum oxidation can be achieved by using gold gaskets with additional gold plating to provide superior shielding.

Profile gaskets are currently available in a variety of shapes and lengths. API's Spectrum Control line of gaskets provide a variety of applications with lightweight and flexible solutions. Various thicknesses and shapes are available. These range from commonly used ones such as rectangular and "D" shape, to uncommon ones such as FL-shape (folding leaf) and DD-shape (Double DD-shape). We are able to produce gaskets with different shapes and sizes, based upon the customer's requests.

The mounting style available for most profile gaskets is pressure sensitive adhesive. These adhesives allow simple place and press mounting on smooth and clean metal surfaces. The parts can be cut to the desired length with common scissors or ordered to the exact length required. The adhesive provides high strength with aggressive initial tack, which increases in strength over time or after exposure to elevated temperatures.

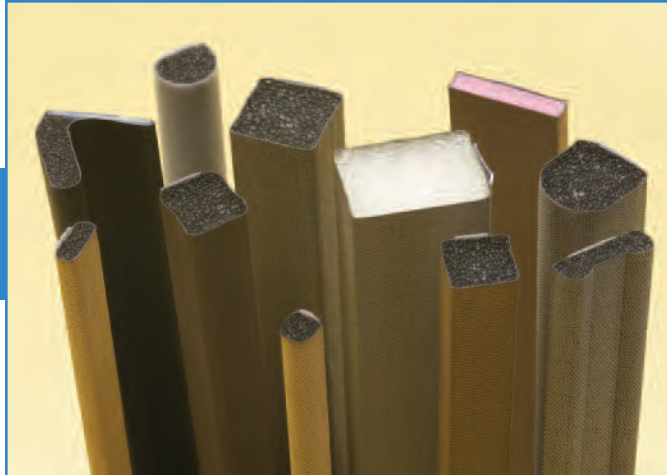

I/O Gaskets

API offers a complete line of standard and custom I/O connector Electromagnetic Shielding Gaskets. I/O gaskets are flat gaskets used to provide a ground contact between a metal connector and the electronic enclosure or mating connector. They ensure that the shield remains continuous from the input/output cable to the electronic enclosure.

I/O Gaskets are available in the same materials as the fabric-over-foam profile gaskets, or as all-metal waved gaskets.

API's line of metal waved gaskets is designed to minimize the gaps between a D-Sub connector and the panel it is mounted to. These gaskets ensure the maximum "gap length" will not exceed the wave pitch, 0.200" (5.08 MM), even on surfaces with poor flatness. This ensures maximum filter performance to 1GHz and beyond.

| Test | Performance |
|--------------------------|-------------------|
| Shielding Effectiveness* | 68 dB - 88 dB |
| Composition (STD) | Woven |
| Plating (STD) | Copper and Nickel |
| Temperature Limit | 200°C |
| Abrasion Resistance | Good |
| Electric Resistance | <0.08 Ohm |
| Flamability Rating** | 94VTM-1, V0 Grade |
| Shelf Life*** | 20 years |

* Provides shielding effectiveness of 68 dB min. between 30 MHz to 1 GHz, this will vary slightly depending on fabric type.

** Rubber rating only.

*** Fabric-over-foam gaskets.

Quietshield™ Fabric-over-Foam Profile Gaskets

Rectangular Type "R"

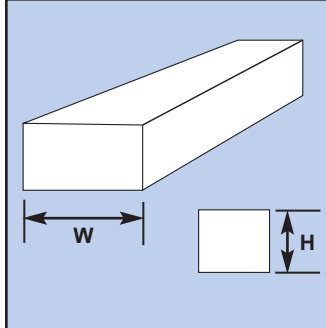

| W | H | Part Number |
|-------|-------|-----------------|
| 1.000 | 0.374 | 57R121C037-xxxx |
| 0.118 | 0.079 | 57R1211208-xxxx |
| 0.154 | 0.118 | 57R1211512-xxxx |
| 0.158 | 0.079 | 57R1211608-xxxx |
| 0.158 | 0.158 | 57R1211616-xxxx |
| 0.130 | 0.189 | 57R1211913-xxxx |
| 0.197 | 0.197 | 57R1212020-xxxx |
| 0.252 | 0.126 | 57R1212512-xxxx |
| 0.315 | 0.472 | 57R1213247-xxxx |
| 0.374 | 0.126 | 57R1213713-xxxx |
| 0.374 | 0.374 | 57R1213737-xxxx |
| 0.394 | 0.394 | 57R1213939-xxxx |
| 0.102 | 0.400 | 57R1214012-xxxx |
| 0.394 | 0.236 | 57R1214022-xxxx |
| 0.488 | 0.370 | 57R1214937-xxxx |
| 0.500 | 0.126 | 57R1215013-xxxx |
| 0.252 | 0.500 | 57R1215025-xxxx |
| 0.500 | 0.500 | 57R1215050-xxxx |
| 0.512 | 0.118 | 57R1215112-xxxx |
| 0.512 | 0.394 | 57R1215140-xxxx |
| 0.984 | 0.394 | 57R1219839-xxxx |

C-Fold Type "C"

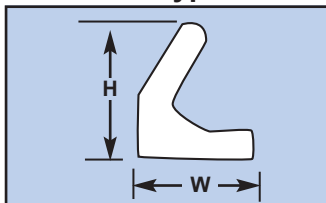

| W | H | Part Number |
|-------|-------|-----------------|
| 0.295 | 0.138 | 57L1213014-xxxx |
| 0.315 | 0.315 | 57L1213232-xxxx |
| 0.394 | 0.394 | 57L1213939-xxxx |
| 0.421 | 0.386 | 57L1214339-xxxx |
| 0.681 | 0.591 | 57L1216859-xxxx |

Flat Type "R"

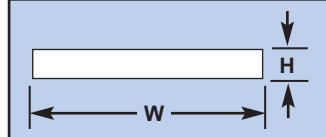

| W | H | Part Number |
|-------|-------|-----------------|
| 0.118 | 0.039 | 57R1211204-xxxx |
| 0.158 | 0.031 | 57R1211603-xxxx |
| 0.158 | 0.035 | 57R1211604-xxxx |
| 0.158 | 0.039 | 57R1211604-xxxx |
| 0.158 | 0.047 | 57R1211605-xxxx |
| 0.197 | 0.020 | 57R1212002-xxxx |
| 0.197 | 0.039 | 57R1212004-xxxx |
| 0.197 | 0.047 | 57R1212005-xxxx |
| 0.197 | 0.059 | 57R1212006-xxxx |
| 0.197 | 0.071 | 57R1212007-xxxx |
| 0.236 | 0.039 | 57R1212404-xxxx |
| 0.236 | 0.059 | 57R1212406-xxxx |
| 0.276 | 0.020 | 57R1212802-xxxx |
| 0.276 | 0.039 | 57R1212804-xxxx |
| 0.276 | 0.047 | 57R1212805-xxxx |
| 0.276 | 0.059 | 57R1212806-xxxx |
| 0.276 | 0.071 | 57R1212807-xxxx |
| 0.299 | 0.063 | 57R1213006-xxxx |
| 0.315 | 0.031 | 57R1213203-xxxx |
| 0.315 | 0.039 | 57R1213204-xxxx |
| 0.354 | 0.039 | 57R1213604-xxxx |
| 0.394 | 0.020 | 57R1214002-xxxx |
| 0.394 | 0.039 | 57R1214004-xxxx |
| 0.394 | 0.047 | 57R1214005-xxxx |
| 0.394 | 0.071 | 57R1214007-xxxx |
| 0.472 | 0.039 | 57R1214704-xxxx |
| 0.472 | 0.059 | 57R1214706-xxxx |
| 0.512 | 0.028 | 57R1215103-xxxx |
| 0.512 | 0.035 | 57R1215104-xxxx |
| 0.512 | 0.059 | 57R1215106-xxxx |
| 0.551 | 0.059 | 57R1215506-xxxx |

P-Shape Type "P"

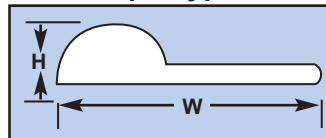

| W | H | Part Number |
|-------|-------|-----------------|
| 0.315 | 0.079 | 57P1213208-xxxx |
| 0.520 | 0.130 | 57P1215216-xxxx |

L-Shape Type "L"

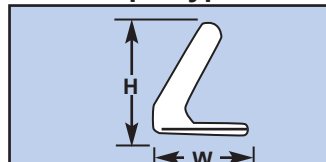

| W | H | Part Number |
|-------|-------|-----------------|
| 0.430 | 0.395 | 57L1214339-7200 |
| 0.433 | 0.433 | 57L1214343-7200 |
| 0.551 | 0.591 | 57L1215559-7200 |
| 0.578 | 0.673 | 57L1215767-7200 |

Knife Edge Type "K"

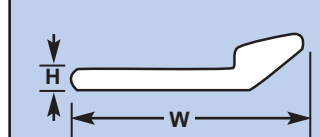

| W | H | Part Number |
|-------|-------|-----------------|
| 0.492 | 0.138 | 57K1214914-xxxx |
| 0.500 | 0.094 | 57K1215009-xxxx |
| 0.500 | 0.098 | 57K1215010-xxxx |
| 0.752 | 0.252 | 57K1217525-xxxx |

Double D-Shape "V"

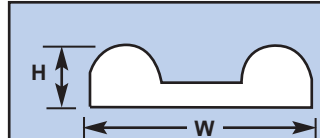

| W | H | Part Number |
|-------|-------|-----------------|
| 0.378 | 0.126 | 57V1213813-xxxx |

Folding Leaf Type "U"

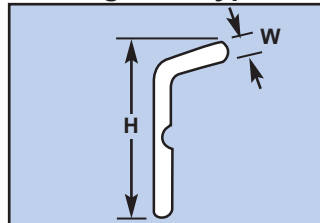

| W | H | Part Number |
|-------|-------|-----------------|
| 0.709 | 0.311 | 57U1217131-xxxx |

Round Type "O"

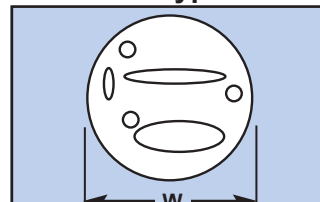

| W | Part Number |
|-------|-----------------|
| 0.098 | 57O1211010-xxxx |
| 0.106 | 57O1211111-xxxx |
| 0.126 | 57O1211313-xxxx |
| 0.177 | 57O1211818-xxxx |
| 0.197 | 57O1212020-xxxx |
| 0.347 | 57O1213535-xxxx |
| 0.394 | 57O1213939-xxxx |
| 0.433 | 57O1214343-xxxx |

D-Shape "D"

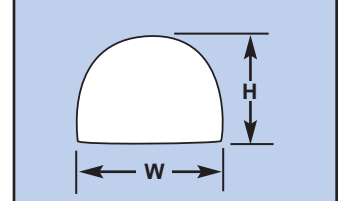

| W | H | Part Number |
|-------|-------|-----------------|
| 0.090 | 0.091 | 57D1210909-xxxx |
| 0.091 | 0.126 | 57D1210912-xxxx |
| 0.102 | 0.126 | 57D1211012-xxxx |
| 0.118 | 0.079 | 57D1211208-xxxx |
| 0.118 | 0.138 | 57D1211214-xxxx |
| 0.150 | 0.059 | 57D1211506-xxxx |
| 0.150 | 0.118 | 57D1211512-xxxx |
| 0.158 | 0.157 | 57D1211616-xxxx |
| 0.197 | 0.197 | 57D1212020-xxxx |
| 0.236 | 0.079 | 57D1212408-xxxx |
| 0.236 | 0.177 | 57D1212418-xxxx |
| 0.236 | 0.197 | 57D1212420-xxxx |
| 0.236 | 0.217 | 57D1212422-xxxx |
| 0.252 | 0.118 | 57D1212512-xxxx |
| 0.256 | 0.134 | 57D1212514-xxxx |
| 0.256 | 0.197 | 57D1212520-xxxx |
| 0.315 | 0.394 | 57D1213240-xxxx |
| 0.354 | 0.118 | 57D1213512-xxxx |
| 0.354 | 0.126 | 57D1213513-xxxx |
| 0.374 | 0.236 | 57D1213725-xxxx |
| 0.386 | 0.252 | 57D1213925-xxxx |
| 0.394 | 0.157 | 57D1213916-xxxx |
| 0.394 | 0.177 | 57D1213918-xxxx |
| 0.394 | 0.197 | 57D1213920-xxxx |
| 0.394 | 0.217 | 57D1213922-xxxx |
| 0.394 | 0.236 | 57D1213924-xxxx |
| 0.394 | 0.276 | 57D1213928-xxxx |
| 0.394 | 0.295 | 57D1213930-xxxx |
| 0.394 | 0.394 | 57D1213939-xxxx |
| 0.433 | 0.138 | 57D1214314-xxxx |
| 0.433 | 0.177 | 57D1214318-xxxx |
| 0.433 | 0.217 | 57D1214322-xxxx |
| 0.709 | 0.551 | 57D1217155-xxxx |
| 0.709 | 0.787 | 57D1217177-xxxx |
| 0.709 | 0.906 | 57D1217191-xxxx |

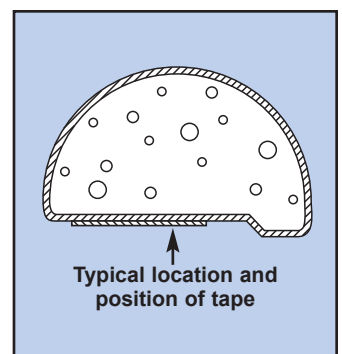

NOTE: All dimensions in inches

Quietshield™ Fabric-over-Foam I/O & Waved Metal Gaskets

Specifications

Material Beryllium Copper, CA 172
(per QQ-C-533)

Finish STD: Electro tin plate, 100 micro inches (per MIL-T-10727)

For RoHS: Nickel - change last 2 p/n digits to - NI

For Hi-Rel: Gold - change last 2 p/n digits to - AU

Material

Thickness005" (.13mm) compressed

Wave

Height030"+.020/-.015
(.76+.51/-.38mm)

Length increase

when flattened 0.008" (.20mm) per inch



Waved Metal Grounding/Shielding Gasket (shown in free state)

Wave Height

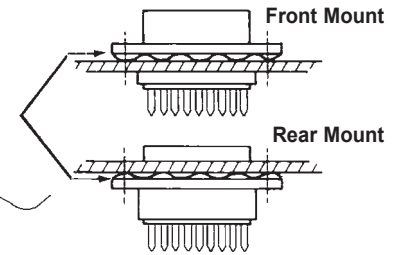

Waved Metal Gaskets (Select part number by filling in "xxx": 572019-00xxx-70)

| Mounting: Front mounted pin or socket connector, rear mounted pin connector. | | | | | | | | |
|--|----------------------|----------------------|----------------------|----------------------|----------------------|-------|--|--|
| Shell Size | A ±.020 (0.51) | B ±.020 (0.51) | C ±.020 (0.51) | D ±.020 (0.51) | E ±.005 (0.13) | "xxx" | | |
| 9 | 1.213 (30.81) | .984 (24.99) | .777 (19.74) | .600 (15.24) | .440 (11.18) | 100 | | |
| 15 | 1.541 (39.14) | 1.312 (33.32) | 1.105 (28.07) | .600 (15.24) | .440 (11.18) | 101 | | |
| 25 | 2.088 (53.04) | 1.852 (47.04) | 1.645 (41.78) | .600 (15.24) | .440 (11.18) | 102 | | |
| 37 | 2.729 (69.32) | 2.500 (63.50) | 2.293 (58.24) | .600 (15.24) | .440 (11.18) | 103 | | |
| 50 | 2.635 (66.93) | 2.406 (61.11) | 2.190 (55.63) | .710 (18.03) | .550 (13.97) | 104 | | |

| Mounting: Rear mounted socket connectors only. | | | | | | | | |
|--|----------------------|----------------------|----------------------|----------------------|----------------------|----------------------|----------------------|-------|
| Shell Size | A ±.020 (0.51) | B ±.020 (0.51) | C ±.020 (0.51) | D ±.020 (0.51) | E ±.005 (0.13) | F ±.005 (0.13) | G ±.020 (0.51) | "xxx" |
| 9 | 1.213 (30.81) | .984 (24.99) | .450 (11.43) | .660 (16.76) | .324 (8.23) | .360 (9.14) | .600 (15.24) | 105 |
| 15 | 1.541 (39.14) | 1.312 (33.32) | .670 (17.02) | .988 (25.10) | .324 (8.23) | .360 (9.14) | .600 (15.24) | 106 |
| 25 | 2.088 (53.04) | 1.852 (47.04) | 1.110 (28.19) | 1.528 (38.81) | .324 (8.23) | .360 (9.14) | .600 (15.24) | 107 |
| 37 | 2.729 (69.32) | 2.500 (63.50) | 1.550 (39.37) | 2.176 (55.27) | .324 (8.23) | .360 (9.14) | .600 (15.24) | 108 |
| 50 | 2.635 (66.93) | 2.406 (61.11) | 1.550 (39.37) | 2.082 (52.88) | .436 (11.07) | .470 (11.94) | .710 (18.03) | 109 |

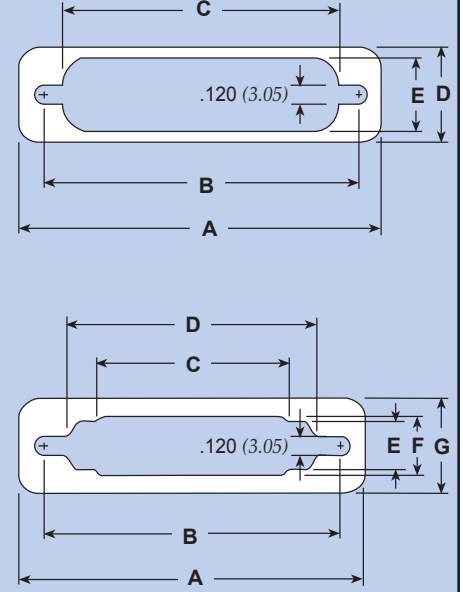

Fabric-over-Foam I/O Gaskets

| Shell Size | Thickness | Dimensions | | | | | | Fabric Type | Part Number |
|------------|-----------|------------------|------------------|------------------|------------------|------------------|----------|-----------------|-------------|
| | | A | B | C | D | E | F | | |
| 1 | 0.012 | 0.746 (18.95) | 1.213 (30.81) | 0.984 (24.99) | 0.400 (10.16) | 0.750 (19.05) | nonwoven | 57F01-D112-1275 | |
| | 0.040 | | | | | | | 57F11-D140-1275 | |
| | 0.070 | | | | | | | 57F11-D170-1275 | |
| 2 | 0.012 | 1.074 (27.28) | 1.541 (39.14) | 1.312 (33.32) | 0.400 (10.16) | 0.750 (19.05) | nonwoven | 57F01-D212-1575 | |
| | 0.040 | | | | | | | 57F11-D240-1575 | |
| | 0.070 | | | | | | | 57F11-D270-1575 | |
| 3 | 0.012 | 1.614 (41.00) | 2.088 (53.04) | 1.852 (47.04) | 0.400 (10.16) | 0.750 (19.05) | nonwoven | 57F01-D312-2075 | |
| | 0.040 | | | | | | | 57F11-D340-2075 | |
| | 0.070 | | | | | | | 57F11-D370-2075 | |
| 4 | 0.012 | 2.266 (57.56) | 2.720 (69.09) | 2.500 (63.50) | 0.400 (10.16) | 0.750 (19.05) | nonwoven | 57F01-D412-2775 | |
| | 0.040 | | | | | | | 57F11-D440-2775 | |
| | 0.070 | | | | | | | 57F11-D470-2775 | |
| 5 | 0.012 | 2.158 (54.81) | 2.63 (66.80) | 2.406 (61.11) | 0.500 (12.70) | 0.850 (21.59) | nonwoven | 57F01-D512-2685 | |
| | 0.040 | | | | | | | 57F11-D540-2685 | |
| | 0.070 | | | | | | | 57F11-D570-2685 | |

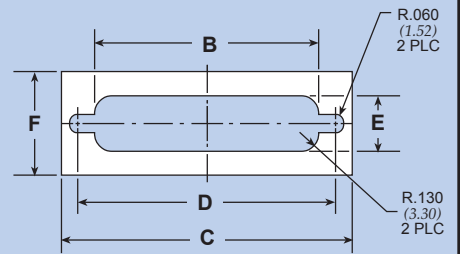

Dimensions in inches (mm)

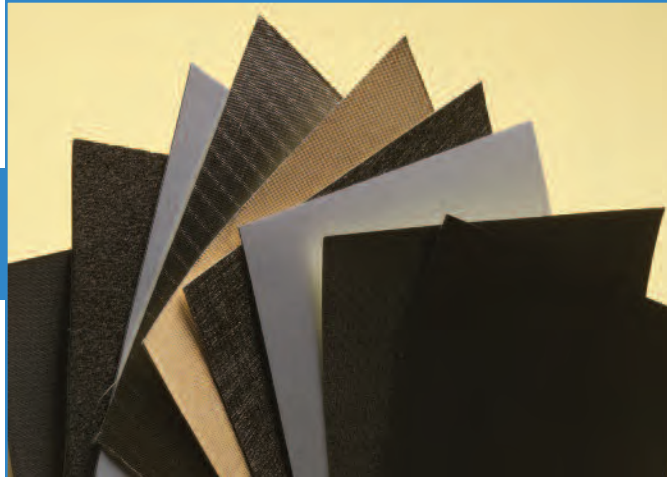

Shielding Tapes & Fabric

Flexible and lightweight tapes provide easy installation and high conductivity and low electrical resistance provide a good shielding effect. Our products use stronger pressure sensitive adhesive to provide better adhesion. Standard widths are 1", 2", 3" and 42". Standard roll lengths are 200'.

API Technologies' Spectrum Control brand of conductive tapes consist of conductive fabric and adhesive which can be either conductive or non-conductive. Conductive tapes come in various types: conductive fabric tapes, Cu/Al foil tapes and double side conductive adhesive tapes. Anticorrosion coating is done on foil tapes and flame retardant coating is available, which complies with UL94VTM-1 and VTM-0.

Styles

- Nonwoven polyester taffeta
- Conductive woven polyester taffeta
- Woven ripstop
- Woven DTY filament
- Mesh
- Aluminum foil
- Copper foil

| Material | Plating | Weight (lb/sf) | Weight (g/sm) | Thickness (mm) | Tensile Strength (Kgf) | Surface Resistance (ohm/sq) | Shielding Effectiveness (min dB) | Part Number |
|----------------------|-------------|----------------|---------------|----------------|------------------------|-----------------------------|----------------------------------|-----------------|
| Conductive Woven | Cu/Ni | 0.015566 | 76.0 | 0.08 | 38.0 | 0.20 | 58 | 57T1A14200-XXXX |
| Conductive Woven | Cu/Ni/Au | 0.005325 | 26.0 | 0.10 | 29.0 | 0.06 | 72 | 57T1A24200-XXXX |
| Conductive Woven | Cu/Ni/Fe | 0.016385 | 80.0 | 0.10 | 32.0 | 0.06 | 63 | 57T1A64200-XXXX |
| Conductive Woven | Cu/Ni/Ag | 0.015975 | 78.0 | 0.10 | 32.0 | 0.06 | 67 | 57T1A34200-XXXX |
| Conductive Woven | Cu/Ni/Resin | 0.016385 | 80.0 | 0.11 | 32.0 | 0.06 | 78 | 57T1A44200-XXXX |
| Conductive Rip-Stop | Cu/Ni | 0.014951 | 73.0 | 0.09 | 39.0 | 0.08 | 62 | 57T2A14200-XXXX |
| Conductive Rip-Stop | Cu/Ni/Ag | 0.015566 | 76.0 | 0.10 | 34.0 | 0.06 | 78 | 57T2A34200-XXXX |
| Conductive Rip-Stop | Cu/Ni/Fe | 0.014951 | 73.0 | 0.09 | 33.0 | 0.06 | 63 | 57T2A64200-XXXX |
| Conductive Rip-Stop | Cu/Ni/Resin | 0.014951 | 73.0 | 0.09 | 34.0 | 0.06 | 68 | 57T2A44200-XXXX |
| Conductive Non-Woven | Cu/Ni | 0.013927 | 68.0 | 0.16 | 10.0 | 0.08 | 72 | 57T0A14206-XXXX |
| Conductive Non-Woven | Cu/Ni | 0.024372 | 119.0 | 0.32 | 21.0 | 0.06 | 80 | 57T0A14201-XXXX |
| Conductive Non-Woven | Cu/Ni | 0.024577 | 120.0 | 0.43 | 30.0 | 0.06 | 83 | 57T0A14202-XXXX |
| Conductive Mesh | Cu/Ni | 0.005120 | 25.0 | 0.08 | 18.0 | 0.20 | 52 | 57T4014200-XXXX |
| Conductive Mesh | Cu/Ni/Resin | 0.005523 | 27.0 | 0.08 | 19.0 | 0.10 | 53 | 57T4044200-XXXX |
| Conductive Mesh | Cu/Ni/Au | 0.003072 | 15.0 | 0.08 | 17.0 | 0.10 | 57 | 57T4034200-XXXX |
| Aluminum | | | | 0.08 | | 0.05 | | 57T7A-4200-XXXX |
| Aluminum | | | | 0.08 | | 0.07 | | 57T7C-4200-XXXX |
| Copper | | | | 0.80 | | 0.02 | | 57T8A-4200-XXXX |

Wire Mesh Gaskets

API's Spectrum Control brand mesh gaskets include all mesh gaskets and elastomer core mesh gaskets.

Layers of knitted wire are covered over the wire core in API's all mesh gaskets. Using its electrical conductivity, they are used between two surfaces to maintain electrical continuity while shielding electromagnetic waves. They offer good resilience and excellent heat and corrosion resistance. Any types of metal can be used to produce mesh gaskets but common materials used are aluminum, stainless steel and monel.



API's elastomer core mesh gaskets are composed of wire mesh over elastomer core. Both these materials provide excellent shielding effects creating the maximum outcome. Both all-mesh gaskets and Elastomer-core mesh gaskets can be produced with different types of materials and also in many different forms.

All Mesh Gaskets - Structure

Rectangular Type "R"

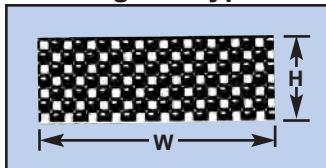

| W | H | Part Number |
|-------|-------|-----------------|
| 0.138 | 0.059 | 57R40-1406-xxxx |
| 0.142 | 0.098 | 57R40-1410-xxxx |
| 0.181 | 0.102 | 57R40-1810-xxxx |
| 0.197 | 0.118 | 57R40-2012-xxxx |
| 0.189 | 0.189 | 57R40-2020-xxxx |
| 0.236 | 0.118 | 57R40-2412-xxxx |
| 0.252 | 0.063 | 57R40-2506-xxxx |
| 0.256 | 0.177 | 57R40-2618-xxxx |
| 0.354 | 0.118 | 57R40-3512-xxxx |

P-Type "P"

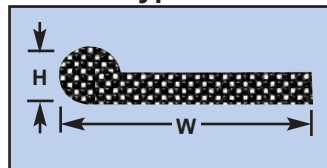

| W | H | Part Number |
|-------|-------|-----------------|
| 0.138 | 0.512 | 57P40-1451-xxxx |
| 0.138 | 0.638 | 57P40-1464-xxxx |
| 0.138 | 0.795 | 57P40-1478-xxxx |
| 0.205 | 0.516 | 57P40-2152-xxxx |
| 0.205 | 0.768 | 57P40-2177-xxxx |
| 0.264 | 0.764 | 57P40-2626-xxxx |

Double P-Type "V"

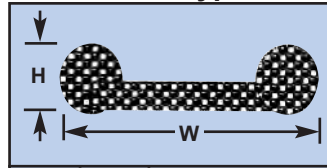

| W | H | Part Number |
|-------|-------|-----------------|
| 0.138 | 0.386 | 57V40-1439-xxxx |
| 0.138 | 0.512 | 57V40-1451-xxxx |
| 0.138 | 0.638 | 57V40-1464-xxxx |
| 0.205 | 0.642 | 57V40-2164-xxxx |
| 0.205 | 0.768 | 57V40-2177-xxxx |
| 0.205 | 1.016 | 57V40-2100-xxxx |
| 0.264 | 0.638 | 57V40-2669-xxxx |
| 0.264 | 0.764 | 57V40-2676-xxxx |
| 0.264 | 1.012 | 57V40-2600-xxxx |

Round Type "O"

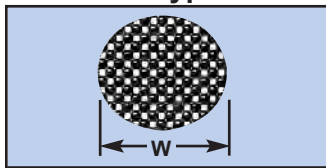

| W | Part Number |
|-------|-----------------|
| 0.039 | 57O40-0404-xxxx |
| 0.059 | 57O40-0606-xxxx |
| 0.079 | 57O40-0808-xxxx |
| 0.102 | 57O40-1010-xxxx |
| 0.138 | 57O40-1414-xxxx |
| 0.157 | 57O40-1616-xxxx |
| 0.185 | 57O40-1919-xxxx |
| 0.217 | 57O40-2222-xxxx |
| 0.307 | 57O40-3131-xxxx |
| 0.362 | 57O40-3636-xxxx |

Elastomer Core Mesh Gaskets

P-Type "P"

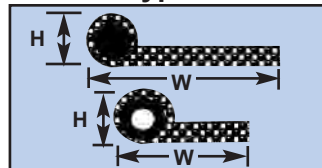

| W | H | Part Number |
|-------|-------|-----------------|
| 0.138 | 0.512 | 57P46-1451-xxxx |
| 0.138 | 0.638 | 57P46-1464-xxxx |
| 0.138 | 0.795 | 57P46-1480-xxxx |
| 0.205 | 0.516 | 57P46-2152-xxxx |
| 0.205 | 0.768 | 57P46-2177-xxxx |
| 0.264 | 0.764 | 57P46-2676-xxxx |

Rectangular Type "R"

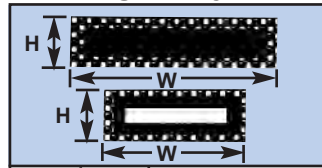

| W | H | Part Number |
|-------|-------|-----------------|
| 0.138 | 0.059 | 57R46-1406-xxxx |
| 0.142 | 0.098 | 57R46-1410-xxxx |
| 0.181 | 0.102 | 57R46-1810-xxxx |
| 0.189 | 0.189 | 57R46-1919-xxxx |
| 0.197 | 0.118 | 57R46-2012-xxxx |
| 0.236 | 0.118 | 57R46-2412-xxxx |
| 0.252 | 0.063 | 57R46-2506-xxxx |
| 0.256 | 0.157 | 57R46-2616-xxxx |
| 0.256 | 0.177 | 57R46-2618-xxxx |
| 0.354 | 0.118 | 57R46-3512-xxxx |

Round Type "O"

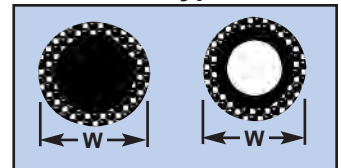

| W | Part Number |
|-------|-----------------|
| 0.039 | 57O46-0404-xxxx |
| 0.059 | 57O46-0606-xxxx |
| 0.079 | 57O46-0808-xxxx |
| 0.102 | 57O46-1010-xxxx |
| 0.138 | 57O46-1414-xxxx |
| 0.157 | 57O46-1616-xxxx |
| 0.185 | 57O46-1919-xxxx |
| 0.217 | 57O46-2222-xxxx |
| 0.307 | 57O46-3131-xxxx |
| 0.362 | 57O46-3636-xxxx |

Double P-Type "V"

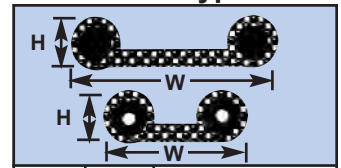

| W | H | Part Number |
|-------|-------|-----------------|
| 0.138 | 0.386 | 57V46-1439-xxxx |
| 0.138 | 0.512 | 57V46-1451-xxxx |
| 0.138 | 0.638 | 57V46-1464-xxxx |
| 0.205 | 1.016 | 57V46-2100-xxxx |
| 0.205 | 0.642 | 57V46-2164-xxxx |
| 0.205 | 0.768 | 57V46-2177-xxxx |
| 0.264 | 1.012 | 57V46-2600-xxxx |
| 0.264 | 0.638 | 57V46-2669-xxxx |
| 0.264 | 0.764 | 57V46-2676-xxxx |

NOTE: All dimensions in inches

Conductive Elastomers



API's Spectrum Control line of conductive elastomers are composed of silicon rubber using its heat resistant property. Unique features of conductive elastomers include water resistance and elimination of static electricity, which is different from general foam gaskets. It also acts as an absorber at high frequency showing 60dB shielding at 30MHz ~ 10GHz.

Excellent electrical conductivity, grounding and shielding are provided. Due to its superior properties conductive elastomers are often used in military equipment. They can be produced in many forms such as sheets, molded parts, die-cuts or strips.

Typical Properties of Silicone Gaskets

| Material | Conductive Silicone (Rubber) Gasket |
|-------------------------|-------------------------------------|
| Hardness Shore Micro | 97-5 |
| Volume Resistivity ohms | 5-10 |
| Elongation % | 240 |
| Tensile Strength Mpa | 4.43 |
| Tear Resistance KN/m | 10.4 |
| Texture and Color | Black or Beige |
| Specific Gravity | 1.39 |
| Temperature Range | -55 to +200 |

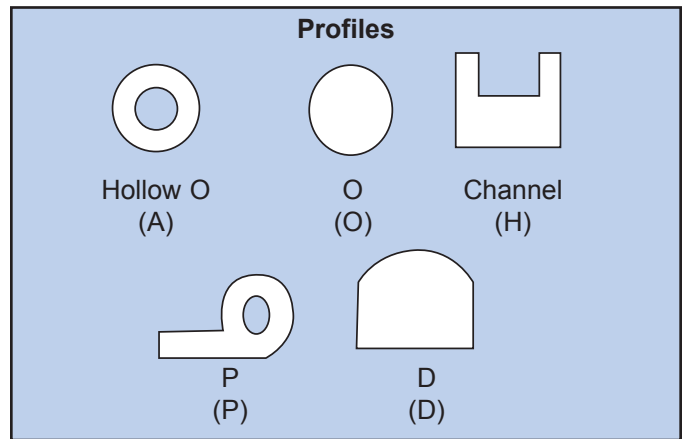

| Part Number | ID Size | OD Size | Type | Profile |
|-----------------|---------|---------|-----------|---------|
| 57A99-0606-xxxx | 0.019 | 0.059 | Hollow | A |
| 57A99-0909-xxxx | 0.039 | 0.091 | Hollow | A |
| 57A99-2828-xxxx | 0.196 | 0.276 | Hollow | A |
| 57D98-2525-xxxx | W:0.250 | H:0.250 | D-Tubing | D |
| 57H98-3022-xxxx | W:0.295 | H:0.217 | Channel | H |
| 57O98-1414-xxxx | | 0.138 | O-Profile | O |
| 57P98-9830-xxxx | W:0.984 | H:0.295 | P-Shape | P |

NOTE: All dimensions in inches

Specialty Connectors & Custom Cable Assemblies

a premium line of custom and specialty filtered and unfiltered connectors with a range of value-added cable and harnessing products

Custom Filtered Connectors provide filtered versions of MIL-STD connectors in custom configurations. Tubular and planar filtered arrays are available with Pi, LC, T and C circuits... **SC3**

Custom Unfiltered Connectors are built to meet various environmental requirements and MIL specifications with power, signal and coax line combinations and multiple terminations available... **SC3**

Mini-MIL Connectors offer space and weight savings with MIL-DTL-38999 equivalent performance... **SC5**

Rapid Mate Connectors provide positive mating force to ensure a reliable connection, offering the ease and reliability of hot shoe style mating with the added benefit of integral EMI filtering.... **SC6**

Harnessing Products and Services are designed in accordance with IPC-A-610 and J-STD-001 for military, commercial and industrial applications. We provide assemblies for both unfiltered and filtered interconnects including lead wire preparation, soldering and tinning, marking and ribbon cable processing... **SC8**

Custom Cable Assemblies include discrete and signal cables, RF cables, power cables, system integration and overmolded connector backshells... **SC9**



- Audio, circular and hermetically sealed connectors
- Connector harnessing built to IAW, IPC-A-610 and J-Std-001
- Complete electro-mechanical assembly and testing services
- Custom connectors can be designed to meet RTCA/DO-160 Section 22 Lightning Strike
- EMI filtered connectors with complex schematics available

For complete specs and drawings, visit www.SpecEMC.com/specconn

Specialty Connectors

Custom Filtered Connectors for MIL & Hi-Rel Applications

API Technologies' Spectrum Control brand offers a complete line of compact and extended shell filtered connectors providing a wide range of design flexibility. Our compact shell filtered connectors offer designers an effective filtering device that reduces the amount of real estate required within a product enclosure. Our extended shell connectors are constructed by adding either planar or tubular capacitor filtering to the rear of a standard connector, which makes them ideal when quick turnaround is required for prototype devices.

Styles offered include the following, as well as custom designs.

- MIL-DTL-38999
- MIL-DTL-55116
- MIL-DTL-83723
- MIL-DTL-24308
- MIL-DTL-26482
- MIL-DTL-5015

We offer tubular and planar style filtered arrays in Pi, LC, T and C circuits with TVS protection also available. Reliability is ensured through 100% testing of each position for critical electrical parameters.

Custom Unfiltered Connectors

API also offers unfiltered custom connector design and manufacturing. Parts can be designed to meet your mechanical and environmental specifications or those of similar QPL connectors.

Features

- Built to MIL specifications
- Custom shells to fit your available space
- Multiple terminations available
- Built to meet various environmental requirements
- Integral strain relief
- Power, signal and coax line combinations

Vertically Integrated

API's Spectrum Control line of custom filtered and unfiltered connector offerings are fully vertically integrated. Components including capacitors and shells are manufactured by API, providing our customers high quality parts at very competitive prices, with the industry's shortest lead times.

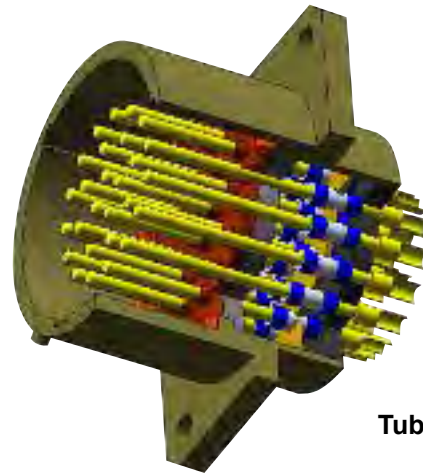

Tubular Filtered Connector

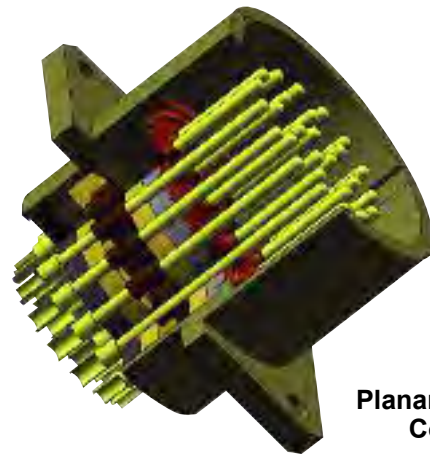

Planar Filtered Connector

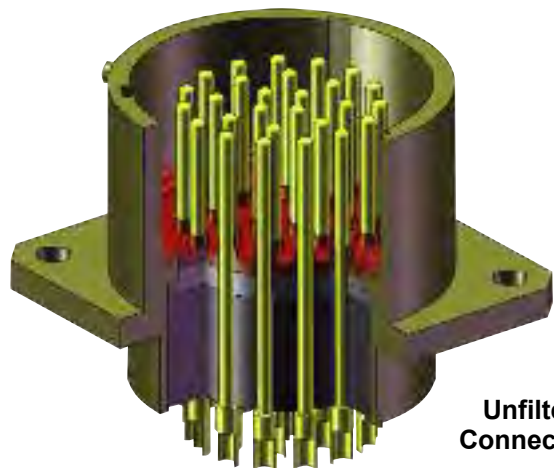

Unfiltered Connectors

For complete specs and drawings, visit www.SpecEMC.com/circular

Custom Filtered Connectors MIL and High Reliability

API's Spectrum Control brand offers a premium line of custom and specialty filtered connectors. These custom high reliability, circular, rack and panel and ARINC connectors have a reputation for superior quality and performance. Several types of filtering are available (See figure at right).

Electrical Specifications

- Operating Temperature -55°C - 125°C
- Capacitance Up to 1 μ F
- Capacitance Tolerance \pm 10%, \pm 20%, +100%
- Capacitance Rating Up to 1500VDC
- Dielectric Withstanding Voltage Up to 3000VDC
- Dissipation Factor < 3.5%
- Insulation Resistance 1000 M Ω , μ F or 10KM Ω

The electrical properties listed above are typical, and can be exceeded based on customer requirements and mechanical configuration. Since many variables affect the design, it is best to contact us directly for a detailed assessment of your connector needs.

Figure A (1)

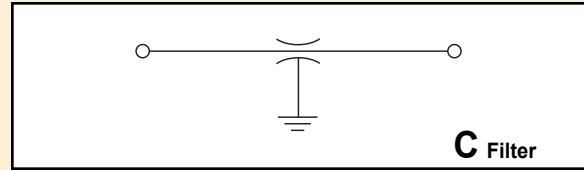

Figure B (2)

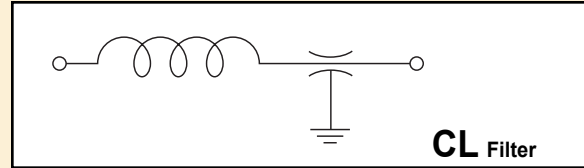

Figure C (3)

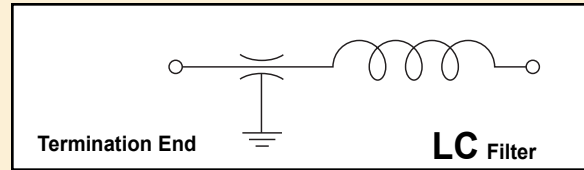
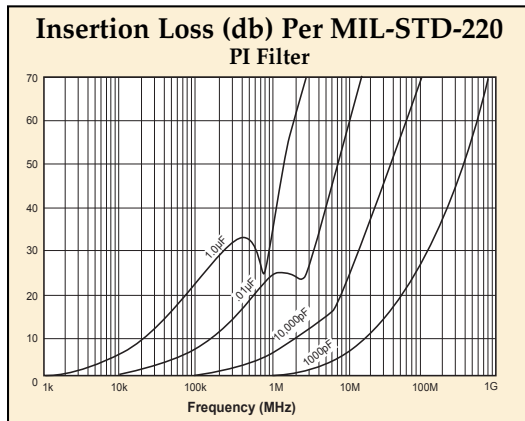
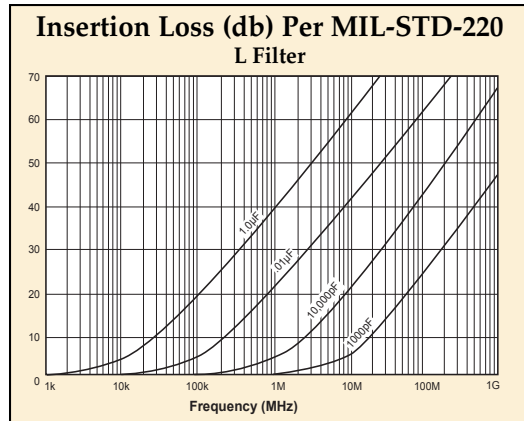
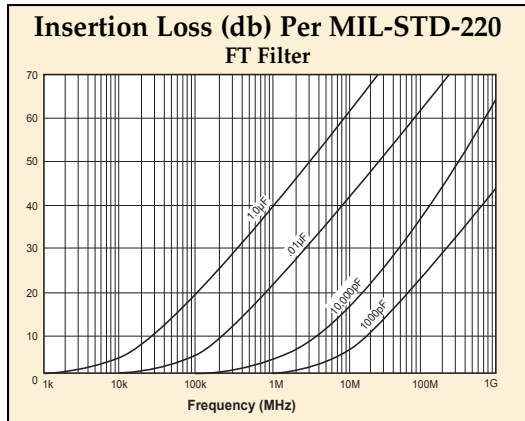
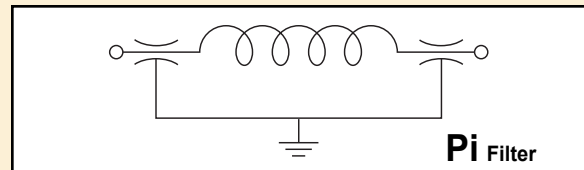

Figure D (4)



Mini-MIL Connectors

API's Spectrum Control line of new Mini-MIL circular connectors are small and lightweight offering space and weight savings while providing equivalent performance to standard MIL-DTL-38999 connectors. These connectors are available filtered with C, Pi or mixed capacitance, or unfiltered, and can be customized to satisfy various mechanical and electrical requirements. These connectors are ideal for military, industrial and medical applications where space restrictions do not allow for larger 38999 connectors.

Specifications

Engagement Types:

- Bayonet
- Single-start UN thread
- Double-start ACME thread
- Triple-start ACME thread

Termination Types:

- PC tail
- Solder cup
- Crimp removable
- Piggyback socket
- Custom

Receptacle Types:

- Flange mount (front or rear mount)
- Jam nut (front or rear mount)
- In-line



Mechanical Specifications

- Shell* Eight shell sizes are available in either pin or socket contact genders
- Shell Materials* Aluminum, stainless steel, composite, custom
- Contacts* Pin and socket contacts are available in 1 to 55 contacts in various combinations of size 23 to size 12.

Electrical Characteristics with C Filter

| Capacitance (pF, GMV)* | Working Voltage | | Dielectric Withstanding Voltage (VDC) | Minimum Insertion Loss (dB) | | | | | |
|------------------------|-----------------|---------|---------------------------------------|-----------------------------|-------|--------|---------|---------|-----------|
| | DC 85°C | AC 85°C | | Cut-Off Freq. MHz | 1 MHz | 10 MHz | 100 MHz | 500 MHz | 1,000 MHz |
| 1,000 | 200 | 115 | 500 | 5 | — | 4 | 21 | 34 | 39 |
| 2,000 | 200 | 115 | 500 | 1 | — | 9 | 26 | 39 | 44 |
| 3,000 | 200 | 115 | 500 | 1 | — | 12 | 30 | 43 | 48 |
| 5,000 | 200 | 115 | 500 | 1 | 1 | 16 | 34 | 46 | 52 |
| 7,000 | 200 | 115 | 500 | 1 | 3 | 19 | 37 | 49 | 55 |
| 10,000 | 200 | 115 | 500 | 1 | 4 | 21 | 39 | 52 | 57 |
| 20,000 | 100 | — | 250 | .50 | 9 | 26 | 44 | 57 | 58 |

Electrical Characteristics with Pi Filter

| Capacitance (pF, GMV)* | Working Voltage | | Dielectric Withstanding Voltage (VDC) | Minimum Insertion Loss (dB) | | | | | |
|------------------------|-----------------|---------|---------------------------------------|-----------------------------|-------|--------|---------|---------|-----------|
| | DC 85°C | AC 85°C | | Cut-Off Freq. MHz | 1 MHz | 10 MHz | 100 MHz | 500 MHz | 1,000 MHz |
| 1,000 | 200 | 115 | 500 | 5 | — | 4 | 28 | 54 | 65 |
| 2,000 | 200 | 115 | 500 | 1 | — | 8 | 39 | 65 | 70 |
| 3,000 | 200 | 115 | 500 | 1 | — | 11 | 47 | 70 | 70 |
| 5,000 | 200 | 115 | 500 | 1 | 1 | 14 | 54 | 70 | 70 |
| 7,000 | 200 | 115 | 500 | 1 | 3 | 18 | 60 | 70 | 70 |
| 10,000 | 200 | 115 | 500 | 1 | 4 | 22 | 64 | 70 | 70 |
| 20,000 | 100 | — | 250 | .50 | 9 | 33 | 70 | 70 | 70 |

* Custom values available.

Rapid Mate Connectors

API's Spectrum Control brand Rapid Mate connectors offer the ease and reliability of hot shoe style mating with the added benefit of integral EMI filtering. By mating via spring loaded, compliant contacts, Rapid Mate connectors provide positive mating force to ensure a reliable connection. This method provides rapid connection with low mating force, allowing for some misalignment during mating.

Additionally, the EMI filter experts at API can design a filtered Rapid Mate connector built to your requirements, providing the advantages of hot shoe style mating while ensuring system functionality in EMI-prone applications.

Applications

- Military and commercial communications systems
- Thermal and ambient light imaging cameras
- Docking stations
- Scanners



EMI Filter Performance

The electrical characteristics table indicates the performance of feed-through capacitors and Pi type filters. Utilize this information to specify the EMI filtering components included in your connector. Selective loading and custom values can also be designed.

Features

- Custom filtering
- 100% tested before shipment
- Rugged and reliable
- Resists sand, dust and water
- Low, flexible mating force

| Filter Designation | Filter* Circuits | Capacitance | | 3 dB Max Cut-off Frequency (MHz) | Working Voltage DC -55°C to +125°C | Minimum Insertion Loss - Decibels (dB) 50 ohm system per MIL-STD-220 (no load) | | | | | | | |
|--------------------|------------------|-------------|-----------|----------------------------------|------------------------------------|--|--------|--------|--------|---------|---------|---------|-------|
| | | Value | Tolerance | | | 5 MHz | 10 MHz | 20 MHz | 50 MHz | 100 MHz | 200 MHz | 500 MHz | 1 GHz |
| A | C | 68 pF | ±20% | 77 | 100V | — | — | — | — | — | 3 | 10 | 16 |
| B | | 100 pF | ±20% | 53 | 100V | — | — | — | — | 1 | 6 | 14 | 19 |
| C | | 135 pF | +100/-0% | 23 | 100V | — | — | — | 1 | 5 | 10 | 16 | 20 |
| D | | 470 pF | ±20% | 11 | 100V | — | — | 2 | 7 | 13 | 19 | 25 | 27 |
| E | | 820 pF | ±20% | 6 | 100V | — | 2 | 6 | 12 | 18 | 24 | 30 | 33 |
| F | | 1000 pF | ±20% | 5 | 100V | — | 3 | 7 | 14 | 20 | 26 | 32 | 35 |
| G | | 1500 pF | ±20% | 3.5 | 100V | 1 | 4 | 10 | 16 | 22 | 29 | 36 | 37 |
| H | | 2500 pF | +100/-0% | 1.3 | 100V | 5 | 11 | 17 | 23 | 29 | 35 | 38 | 40 |
| I | | 4000 pF | +100/-0% | .8 | 100V | 9 | 15 | 21 | 27 | 34 | 38 | 42 | 46 |
| J | Insulated | 10 pF | Max. | 635 | 100V | — | — | — | — | — | — | — | — |
| K | Grounded Insert | | | | | — | — | — | — | — | — | — | — |
| L | Pi | 68 pF | ±20% | 65 | 100V | — | — | — | — | 1 | 6 | 17 | 23 |
| M | | 100 pF | ±20% | 46 | 100V | — | — | — | — | 2 | 9 | 22 | 28 |
| N | | 135 pF | +100/-0% | 25 | 100V | — | — | — | 1 | 6 | 17 | 26 | 34 |
| O | | 470 pF | ±20% | 11 | 100V | — | — | — | 9 | 18 | 22 | 36 | 43 |
| P | 820 pF | ±20% | 6 | 100V | — | — | 4 | 13 | 23 | 31 | 45 | 52 | |
| Q | 1000 pF | ±20% | 5 | 100V | — | 2 | 7 | 16 | 24 | 36 | 51 | 59 | |
| R | 1700 pF | +100/-0% | 1.9 | 100V | 1 | 6 | 14 | 28 | 35 | 49 | 64 | 69 | |
| S | 2500 pF | +100/-0% | 1.3 | 50V | 4 | 9 | 16 | 28 | 41 | 54 | 70 | 70 | |
| T | 5000 pF | +100/-0% | .7 | 100V | 9 | 15 | 28 | 41 | 53 | 66 | 70 | 70 | |

Quality Acceptance Test Specifications

All filtered connectors undergo extensive testing to assure that all product meets our high quality expectations. Many of the tests are performed 100% as routine and others are carried out on a sample basis when this is deemed more meaningful.

Visual

The connectors shall be manufactured and processed in a careful and workmanlike manner in accordance with good design and sound practice. All connectors shall be checked 100% to insure dimensions are as shown in this catalog.

Capacitance

Checked on 100% of the contacts per detailed specifications when measured @ 25°C, 1 KHz, 0.1 to 1.0VRMS. On insulated feed-thru lines, the maximum capacitance is 25 pF.

Dissipation factor

4% maximum, checked 100% @ 25°C, 1KHz, 0.1 to 1.0VRMS

Dielectric withstanding voltage

Performed on 100% of the filtered contacts. The test voltage unless otherwise specified will be 2.5 times the working voltage as specified at 25°C. This voltage will be applied for 1 to 5 seconds with the charging current limited to 50 milliamps.

Insulation resistance

Performed on 100% of the filtered contacts at 25°C. The minimum acceptance level will be 1000 megohms at 25°C and 100 megohms at 125°C if required. This test will be carried out in accordance with MIL-STD-202 Method 302, test voltage of 100VDC or at rated voltage whichever is less.

Insertion loss

Performed on a sample quantity of filtered contacts, minimum acceptance levels as specified by typical insertion loss graphs.

Resistance to ground

The RDC on ground lines is 5 milliohms max.

Marking

As a minimum, all connectors shall have the Spectrum part number, date code and logo. Upon request, customer specified marking can be incorporated into the manufacturing cycle.

Special Testing

Spectrum has a fully qualified test laboratory and is willing to provide additional acceptance testing upon customers request, at minimal additional costs.

Minimum Design Specifications

All of the filtered connectors are designed to meet minimum standards shown in table below.

Environmental Performance

| Test* | MIL-STD-1344 | | MIL-STD-202 | | Comments** |
|---------------------------|--------------|-----------|-------------|-----------|-----------------------------------|
| | Method | Condition | Method | Condition | |
| Vibration | - | - | 204 | G | 30G for 10 to 2000 Cycles |
| Thermal Shock | - | - | 107 | A-1 | Except Step 3 is +125 degrees C |
| Immersion | 1016 | - | 104 | A | - |
| Salt Spray | 1001 | - | 101 | B | - |
| Moisture Resistance | 1002 | II | 106 | - | Except Step 7 |
| Shock | 2004 | - | 213 | I | - |
| Barometric Pressure | 3001 | - | 105 | C | 125% rated voltage |
| Resistance to Solder Heat | - | - | 210 | B | - |
| Terminal Strength | - | - | 211 | A | The applied force shall be 5 lbs. |
| Contact Resistance | - | - | 307 | - | .0152 max. |
| Life | - | - | 108 | D | 1000 hrs. |
| Durability | - | - | - | - | 500 cycles |
| Solderability | - | - | 208 | - | - |

* All tests are performed per applicable MIL spec.

** All parts will meet post test electricals (i.e. dielectric withstanding voltage, insulation resistance, capacitance, insertion loss and visual/mechanical).

Harnessing Products & Services

API Technologies' Spectrum Control brand offers custom harnessing products and services for military, aerospace, commercial and industrial applications. Our skilled operators and supervisors work in a modern well-equipped facility to provide interconnect assemblies made to the highest workmanship standards.

Our manufacturing engineers design tooling and fixturing, which meet the tightest tolerances. From simple to complex, API can provide assemblies in compliance with all requirements.

Product Capabilities

- Built in accordance with IPC-A-610 and J-Std-001
- Cable harnessing
- Wide range of interconnects
- Coaxial and RF cabling
- Flat ribbon cable
- High voltage
- Electro-mechanical assembly

Manufacturing Capabilities

- Lead wire preparation
- Soldering and tinning
- Strip and removal of insulation
- Wire, component and assembly marking
- Ribbon cable processing



Wire Harnesses

API will add wires to a filtered or unfiltered connector to allow the customer to easily install the connector into the system at a lower cost. These value-added services include adding wires terminated or unterminated to all lines or only select lines, twisted pairs and labeling of wires for easy placement in your system. We can also encapsulate the wires inside the connector adding strength to the total harness.

By contracting API to add the harness assembly, customers are assured the performance of the connector has not been adversely affected. **All of our custom connectors are 100% tested for integrity and effective performance.**

API's connector manufacturing operators are all certified to MIL-STD-2000 solder specification. We have invested in this certification to provide you with confidence that the quality of our custom construction meets the highest standards in the industry.

Markets Served

- | | |
|---------------|----------------------------|
| ■ Medical | ■ MIL Spec |
| ■ Electronics | ■ Military instrumentation |
| ■ Automotive | ■ Marine |
| ■ Telecom | ■ Industrial |

Custom Cables Assemblies

API Technologies' Spectrum Control brand has developed a range of capabilities to produce custom cable assemblies that deliver dependable operation and cost savings in high reliability/high value applications. We can integrate any of API's extensive family of EMI connectors and components, RF filters and subsystems and power management systems or use industry standard components. As a vertically integrated manufacturer, we utilize our dedicated facility that is AS9100 Rev C/ISO 9001:2008 certified to produce the highest quality custom cable assemblies in the industry's shortest lead times. We also have in-house low and high volume PCB manufacturing capabilities.

Signal & Discrete Cables

- Point-to-point, multi-conductor, branched harness, flex, semi-rigid, and rigid circuit card assembly
- API supplied EMI filtered and custom non-filtered connectors and EMI filters

RF Cables

- Frequency up to 40 GHz
- Phase matching
- Rigid/semi-rigid cable
- Custom RF cable builder tool

Power Cables

- Current ratings up to 750 amps
- Cooper "Roughneck" 4/00 + power distribution cable fabrication
- API supplied power management solutions

Systems Integration

- In-house machining capabilities
- In-house EMI/RF filters, connectors, PDU's, turn key
- Vertically integrated manufacturing approach
- Basic box builds through complex systems
- In-house high and low volume PCB manufacturing capabilities

API custom cable assemblies are ideal for aerospace, military, high-end commercial and medical applications.



Overmolded Connector Backshells

API offers an alternative to the traditional connector backshell that improves performance while providing significant cost savings. Our overmolded connector backshells are completely weather sealed and EMI shielded and cost a fraction of a typical connector backshell. We machine our own overmolded backshells and then seal the attached wires and shielding with an extremely durable mold material. The result is a more attractive connector that is far more resistant to environmental conditions and costs 10 to 20 times less than traditional backshells.

- API overmold backshells available for almost any connector configuration
- Overmolding provides better strain relief than heat shrink or metal backshells
- Total encapsulation of mold material protects against weather and environmental degradation
- Overmolded connector is 10 to 20x less expensive than traditional backshells
- More attractive final assembly, custom mold imprinting available

EMI Power Filters & Film Capacitors

find the ideal method to filter the AC or DC power entering your system to prevent radiated or conducted EMI with our line of standard power filters and custom power solutions



EMI Filter Expertise

We differentiate ourselves from typical filter suppliers by offering our customers an integrated approach to EMC problem solving through consulting, diagnostic testing, design and manufacturing.

- In-house test facilities to provide a total solution for your compliance issues – anechoic chamber, shielded room and NARTE certified engineers ready to test for European emission and immunity regulations, FCC Part 15 and MIL standards

Power Entry Modules, Power Line & 3 Phase Power Filters are designed in multiple configurations to cover a range of industrial applications. These have excellent attenuation for high voltage impulse, are available in single and dual stage and address FCC Part 15 regulations while meeting your power filtering needs... **PF5-PF6 & PF16-PF89**

Single Line Feed-Through (SLFT) Power Filters provide superior filtering in a compact, durable package with single, dual, and triple feed-throughs available. These filters are ideal for meeting broad frequency applications with a bolt-in style for easy installation... **PF7-PF14**

Military/Aerospace Multisection Filters provide excellent EMI filtering for demanding high reliability applications. We offer standard filters, as well as custom designed mechanical packages for unusual or tight fitting spaces and higher performance filtering and expanded voltage ratings... **PF91-PF98**

EMI Power Filter Solutions will lower your costs and reduce your time to market while providing your system with protection from radiated or conducted EMI. Our comprehensive consulting, diagnostic testing and world class manufacturing allows us to meet your design/project parameters... **PF99**

Power Film Capacitors deliver high reliability, low inductance, low ESR and low DF with a high peak withstanding voltage. These ruggedized capacitors come in a wide range of dielectrics, various geometries, a variety of terminations, multiple sizes and electrical ratings of 250-15KVDC typical, ripple currents up to 400 Arms and 150°C operation... **PF100**

Audio Film Capacitors with multiple dielectrics in metalized film and film/foil construction. High quality capacitors specially designed for audio applications... **PF102**

- Global manufacturing and design support with agency approved products available
- Engineering expertise and vertical integration reduce your time to market and save you money
- High reliability products with low leakage and nonmagnetic options available
- Available to meet MIL-PRF-15733 and MIL-STD-461 standards



Application Guidelines

Need for EMI suppression

Global regulatory agencies have established limits to the amount of noise that man-made electronic devices can radiate or conduct. These regulations have gained greater importance as the world's electronic population intensifies and the proximity of electronic devices becomes closer.

EMI can propagate through two basic avenues: Conducted and Radiated

Conducted refers to events where the EMI energy flowthrough power lines, data cables and other wiring that carries functional data or power.

Radiated refers to energy that is propagated by magnetic or electric fields, which originate from other electronic or electrical systems.

Interference types

There are two modes of conducted noise: differential mode (symmetrical or normal mode) and common mode (asymmetrical mode).

Differential mode interference signals are present on one side of the line, referenced to the other. The currents flow along one phase and return along another phase.

Common mode interference signals are present on both sides of the line referenced to ground. The current flows from the source to ground along the ground path and returns along the phases.

Sources of EMI

Electromagnetic interference can occur naturally or through electronic sources. Lightning discharges, precipitation, sand and dust storms, and cosmic noise are sources of natural EMI.

EMI generated from power electrical products cause the most concern. These man-made sources, such as power lines, rotating machinery, power supplies and electronic transmission devices, all have their own signatures and noise pollution.

EMI filters, insertion loss and attenuation

Power line EMI filters are designed to attenuate (or reduce) all radio frequency emissions or energy that is above the applicable EMC specification. Most power line EMI filters utilize inductor/capacitor "low pass" component configurations that pass all DC or low frequency AC necessary energy and attenuate (suppress) higher frequencies containing noise or unwanted energy.



Power Filter Installation

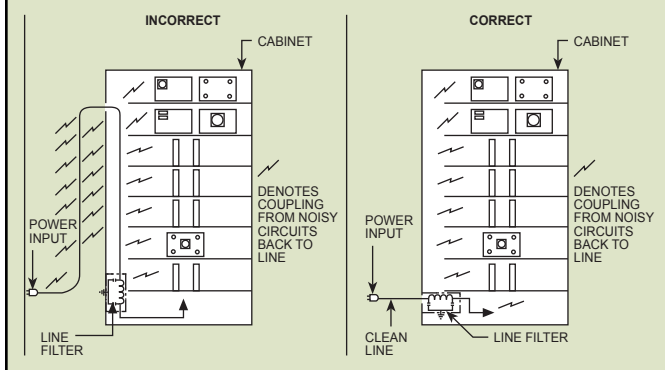

To insure a customer's "in system" unit to unit attenuation uniformity of power line filters, an insertion loss production line test is performed by API Technologies.

Each of the specific frequencies is measured using RF test equipment and the "reference signal level" of each frequency is stored. Some systems sweep the entire frequency range and store this "reference signal level". The filter to be measured, tested, or evaluated is then "inserted" between the generator and receiver that established the stored "reference signal level" on the RF test analyzer.

The measured difference without a filter ("the reference signal level") and with the filter "inserted" into the RF test equipment/analyzer is defined as insertion loss. The unit of measure for insertion loss is the decibel (dB). As noted on most curves in this bulletin, as frequency increases, the higher the insertion loss or dB value. The plot of frequency versus dB value establishes the typical insertion loss curve.

Installation Criteria

Proper installation of a filter network is critical to achieving successful filtering of electromagnetic interference. API recommends that power line filters be installed where the power line enters the equipment. The filter acts as a barrier between polluted energy and clean energy going into your equipment. It is important that the filter is connected to an effective ground plane and where proximity does not couple radiated noise to the clean lines.

Measurement Guidelines

API Technologies has the capability to perform a wide range of tests for EMI filters. Unique custom testing systems designed by Spectrum assure the accuracy required in today's demanding environments. Testing is performed by employing a 50 ohm source and load impedance per MIL-STD-220. The individual filter performance is stated in terms of insertion loss. Overall attenuation reflects the filter's interaction within the system. Individual filter performance may differ from system to system and each application should be verified through system testing. Examples of various testing abilities and configurations are outlined below.

Differential (Normal or Symmetrical) Mode Insertion Loss

Differential mode noise is caused by non-sinusoidal conduction of rectifiers and other switching devices creating harmonic distortion.

This noise is predominant from the power frequency to approximately 10 MHz. Since it follows conventional current flow, it is considered to be of the same magnitude but opposite phase of the other line. Spectrum measures differential mode insertion loss in a 50 ohm system with Balun transformers as shown.

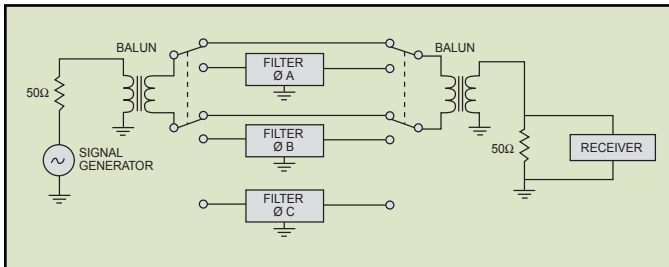

Common (Asymmetrical) Mode Insertion Loss

Since common mode insertion loss is of the same phase as the opposite line, they may not be of the same magnitude, depending on the end system circuitry. Spectrum Control tests common mode insertion loss on each line in a 50 ohm system as shown.

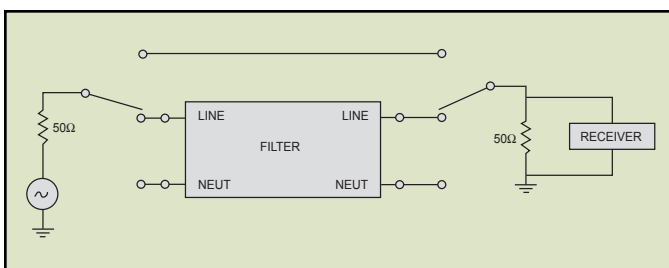

Leakage Current

Leakage is a measurement of reactive current (capacitance) to ground per line. Spectrum uses the following test setup for leakage current measurement.

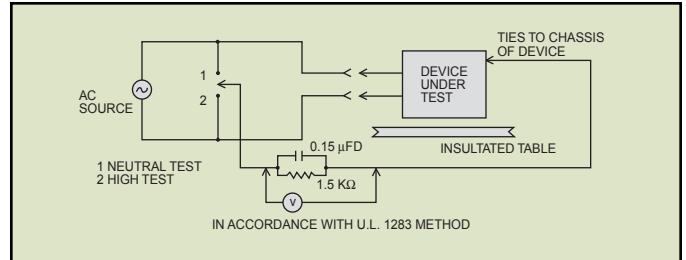

AC Voltage Drop

AC voltage drop is defined as $E_{in} - E_{out} = AC$ voltage drop.

Spectrum Control uses the following circuit for AC voltage drop testing:

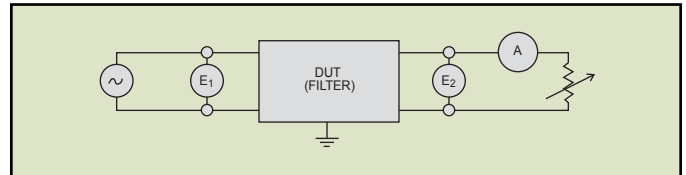

DC Voltage Drop

DC voltage drop is performed on each line individually. This test provides the total DC voltage drop for that line of the filter. The following circuit is used in testing:

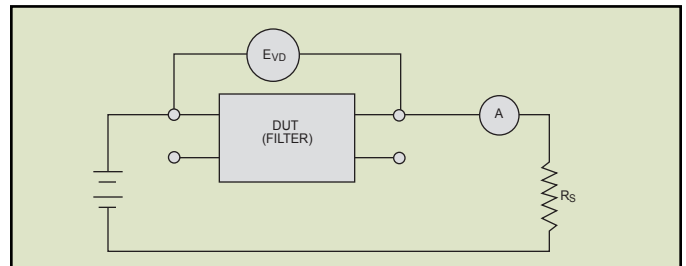

Power Entry Modules, Power Line Filters & 3 Phase Power Filters Part Numbering System

Part Numbering System

Example: **12-PMB-025-5-A**

Part number 12-PMB-025-5A represents a power line filter with threaded studs, current rated for 25 Amps and with a leakage current of 0.50 mA.

| | | | | | | | | |
|---|---|---|---|---|---|---|---|---|
| 12 | - | PMB | - | 025 | - | 5 | - | A |
| Product Line Series | | Product Style | | Current Rating | | Leakage Current (Y Cap) | | Outline Drawing/ Case Style |
| <ul style="list-style-type: none"> 10 = Filtered IEC Inlets 11 = Printed Circuit Board Mount 12 = Power Line Filters 13 = Three Phase Power Line Filters 14 = Fused or Switched & Fused Power Entry Filters (250V) 15 = Switched & Dual Fused 16 = Single Phase (250V) | | <ul style="list-style-type: none"> BBF = 3 Phase, terminal block connection BFF = Bolt-in fused filter BPF = Bolt-in IEC w/Fast-on rear terminals BPL = Bolt-in IEC w/wire lead termination BSF = Bolt-in switched & fused CCL = Cylindrical, capacitive inputs w/Fast-ons CLF = Cylindrical, inductive inputs w/wire leads MMB = Multiple stage filtering w/threading studs MMF = Multiple stage filtering w/Fast-on terminal MPC = Miniature PCB mountable PDB = 3 Phase, delta w/threaded studs PDF = 3 Phase, delta w/Fast-ons PDL = 3 Phase, delta w/wire leads PMB = Power line filter w/threaded studs PMF = Power line filter w/Fast-ons PML = Power line filter w/wire leads PWB = 3 Phase, wye w/threaded studs PWE = 3 Phase, wye w/busbar PWF = 3 Phase, wye w/Fast-ons PWL = 3 Phase, wye w/wire leads | | <ul style="list-style-type: none"> 001 = 1.0 Amp 002 = 2.0 Amps 003 = 3.0 Amps 005 = 5.0 Amps 006 = 6.0 Amps 010 = 10 Amps 015 = 15 Amps 016 = 16 Amps 020 = 20 Amps 025 = 25 Amps 030 = 30 Amps 035 = 35 Amps 050 = 50 Amps 080 = 80 Amps 100 = 100 Amps 150 = 150 Amps 160 = 16.0 Amps 200 = 200 Amps 300 = 300 Amps 400 = 400 Amps 500 = 500 Amps 600 = 600 Amps | | <ul style="list-style-type: none"> 250 VAC 0 = 0.075 mA 1 = 0.01 mA 2 = 0.20 mA 3 = 0.35 mA 4 = 0.10mA 5 = 0.50 mA 6 = 0.60 mA 7 = 0.70 mA 8 = 1.0 mA 9 = 3.0 mA 10 = 2.0 mA 11 = 1.5 mA 12 = 4.5 mA 13 = 9.0 mA 14 = 20.0 mA 15 = 15.0 mA 17 = 33.0 mA 18 = 71.5 mA DC = DC | | <ul style="list-style-type: none"> 1 Select case style from following <ul style="list-style-type: none"> * Cylindrical * Power line w/Fast-on * Power line w/threaded studs * Power line w/wire leads * PCB mount * Large case 3 Phase delta * Large case 3 Phase wye * IEC Inlet 2 Refer to drawing list per selected case style 3 Letter at the end of the part is found in the case style drawing list: A, B, C, D, E, F, etc. |

* Note: Not all series offer the product style, rating and leakage current

Power Entry Modules, Power Line Filters & 3 Phase Power Filters Part Numbering System

Part Numbering System

Example: **60-BPR-060-5-4**

Part number 60-BPR-060-5-4 represents a power entry module, bolt-in style with fast-on terminals, a current rating of 6 Amps, leakage current of 0.50 mA and capacitance of 0.047 μ F.

| 60 | - | BPR | - | 060 | - | 5 | - | 4 |
|--|---|---|---|------------------------|---|-------------------------|---|---|
| Product Line Series | | Product Style | | Current Rating | | Leakage Current (Y Cap) | | Capacitance (X Cap) |
| 60 = Power Entry Modules | | AFL = Appliance filter w/ inductive input | | 010 = 1.0 Amps | | 250 VAC | | 0 = none |
| 61 = Mini PCB Power Filters | | AFC = Appliance filter w/ capacitive input | | 015 = 1.5 Amps | | 0 = 0.075 mA | | 1 = 0.01 μ F |
| 62 = Power Line Filters | | ARL = AFL plus bleeder resistor | | 016 = 1.6 Amps | | 1 = 0.01 mA | | 2 = 0.022 μ F |
| 63 = Three Phase Power Line Filters | | BFF = Fused filter w/ Fast-on terminals | | 020 = 2.0 Amps | | 2 = 0.20 mA | | 3 = 0.033 μ F |
| 64 = Fused or Switched & Fused Power Entry Filters (250V) | | BFS = Fused filter w/solder lug terminals | | 030 = 3.0 Amps | | 3 = 0.35 mA | | 4 = 0.047 μ F |
| 65 = Fused or Switched & Fused Power Entry Filters (125V) | | BHP = High frequency bolt-in for PCB | | 040 = 4.0 Amps | | 4 = 0.10 mA | | 5 = 0.050 μ F |
| 66 = Fused or Switched & Fused Low Leakage Power Entry Filters (250V) | | BHS = High frequency bolt-in w/solder lugs | | 050 = 5.0 Amps | | 5 = 0.50 mA | | 6 = 0.068 μ F |
| 67 = Fused or Switched & Fused Low Leakage Power Entry Filters (125V) | | BPF = Bolt-In right angle terminals | | 060 = 6.0 Amps | | 6 = 0.60 mA | | 01 = 2 x 0.01 μ F |
| 68 = Switched & Dual Fused Power Entry Filters | | BPL = Bolt-in w/wire leads | | 080 = 8.0 Amps | | 7 = 0.70 mA | | 02 = 0.10 μ F & 0.22 μ F |
| 69 = Dual Fused Only or Dual Switched Only Power Entry Filters | | BPP = Bolt-in PCB mount | | 100 = 10.0 Amps | | 8 = 1.00 mA | | 04 = 2 x 0.22 μ F |
| | | BPR = Bolt-in w/Fast-on tab terminals | | 150 = 15.0 Amps | | 9 = 3.00 mA | | 06 = 2 x 0.4 μ F & 0.22 μ F |
| | | BPS = Bolt-in w/ solder lug terminals | | 160 = 16.0 Amps | | | | 10 = 0.15 μ F |
| | | BSF = Bolt-in switched & fused | | 200 = 20.0 Amps | | | | 11 = 0.10 μ F |
| | | MMF = Metal case w/fast-on tabs | | 300 = 30.0 Amps | | | | 12 = 0.22 μ F |
| | | MPC = Miniature printed circuit board | | 400 = 40.0 Amps | | | | 13 = 0.33 μ F |
| | | PMB = Metal case w/bolt-on terminals | | | | | | 14 = 0.47 μ F |
| | | PMF = Metal case w/Fast-on tabs | | | | | | 16 = 0.22 μ F & 2 x 0.33 μ F |
| | | PML = Metal case w/wire leads | | | | | | 21 = 1.00 μ F |
| | | PPF = Plastic case w/Fast-on tabs | | | | | | |
| | | PQF = Plastic case w/Fast-on tabs | | | | | | |
| | | PRF = Plastic case w/Fast-on tabs | | | | | | |
| | | SOF = Switched filter w/ Fast-on tabs | | | | | | |
| | | SOS = Switched filter w/ solder tabs | | | | | | |
| | | SPL = Snap-in w/wire leads | | | | | | |
| | | SPR = Snap-in w/Fast-on terminals | | | | | | |
| | | SPS = Snap-in w/solder lug terminals | | | | | | |
| | | SSF = Snap-in switched & fused | | | | | | |
| | | ARC = AFC plus bleeder resistor | | | | | | |

* Note: Not all series offer the product style, rating and leakage current

High Current DC Single Line Feed-through Series



RoHS
COMPLIANT

Features

- Voltage rating of 130VDC
- C configuration with Class Y4 capacitors
- Current rating up to 300 Amps
- Operating temperature range: -40°C to +85°C
- Excellent filtering in compact package
- Bolt-in style with D-shaped bushing for easy installation
- Low cost EMI solution
- Design flexibility
- UL and Semko approved

Applications

- Telecommunications (cellular base stations, telephone switching racks, etc.)
- Power supplies
- Medical equipment
- C.O.T.S. (Commercial-Off-The-Shelf) Military
- Industrial equipment controls
- Data transmission equipment

Specifications

| Part Number | Rated Current | Min. Cap. | Minimum Insertion Loss (db)* | | | | | | |
|----------------|---------------|-----------|------------------------------|--------|------|-------|--------|---------|----|
| | | | .01MHz | .10MHz | 1MHz | 10MHz | 100MHz | 1000MHz | |
| 52F226-011-10 | 10A | 10nF | - | - | 4 | 21 | 41 | 60 | |
| 52F226-011-16 | 16A | | | | | | | | |
| 52F226-011-32 | 32A | | | | | | | | |
| 52F226-011-63 | 63A | | | | | | | | |
| 52F226-011-100 | 100A | 47nF | | 2 | 15 | 34 | 53 | 74 | |
| 52F226-011-200 | 200A | 100nF | | 5 | 21 | 40 | 60 | 85 | |
| 52F226-011-250 | 250A | | | | | | | | |
| 52F226-011-300 | 300A | | | | | | | | |
| 52F226-021-16 | 16A | 47nF | | 2 | 2 | 15 | 34 | 53 | 74 |
| 52F226-021-32 | 32A | | | | | | | | |
| 52F226-021-63 | 63A | | | | | | | | |
| 52F226-021-100 | 100A | 100nF | 5 | | 21 | 40 | 60 | 85 | |
| 52F226-021-200 | 200A | 470nF | 16 | | 33 | 52 | 75 | 90 | |
| 52F226-021-250 | 250A | | | | | | | | |
| 52F226-021-300 | 300A | | | | | | | | |
| 52F226-031-16 | 16A | 100nF | - | | 5 | 21 | 40 | 60 | 85 |
| 52F226-031-32 | 32A | | | | | | | | |
| 52F226-031-63 | 63A | | | | | | | | |
| 52F226-031-100 | 100A | 470nF | | 2 | 16 | 33 | 52 | 75 | |
| 52F226-031-200 | 200A | 1000nF | | 6 | 20 | 40 | 60 | 85 | |
| 52F226-031-250 | 250A | | | | | | | | |
| 52F226-031-300 | 300A | | | | | | | | |
| 52F226-041-16 | 16A | 470nF | | 2 | 16 | 33 | 52 | 75 | 90 |
| 52F226-041-32 | 32A | | | | | | | | |
| 52F226-041-63 | 63A | | | | | | | | |
| 52F226-041-100 | 100A | 1000nF | 6 | | 20 | 40 | 60 | 85 | |
| 52F226-041-200 | 200A | 4700nF | 15 | | 35 | 54 | 74 | 90 | |

* Optimum performance with proper installation

High Current DC Single Line Feed-through Series

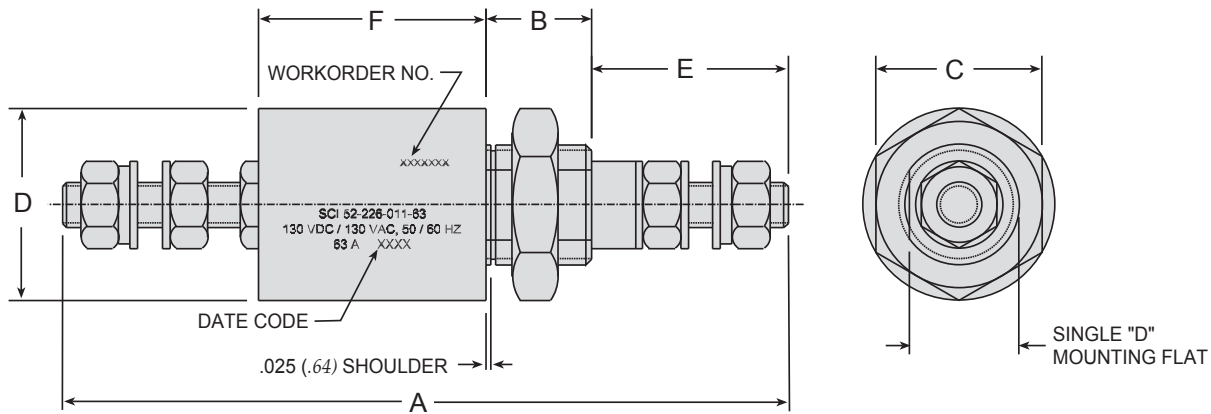

Dimensions

| Part Number | A | B | C | D | E | F |
|----------------|------------|-----------|-----------|--------------|-----------|-----------|
| 52F226-011-10 | 2.24 (57) | 0.39 (10) | 0.51 (13) | 0.56 (14.29) | 0.63 (16) | 0.71 (18) |
| 52F226-011-16 | 2.48 (63) | 0.47 (12) | 0.67 (17) | 0.75 (19.05) | 0.71 (18) | |
| 52F226-011-32 | | | | | | |
| 52F226-011-63 | 3.78 (96) | 0.55 (14) | 0.87 (22) | 1 (25.40) | 1.02 (26) | 1.18 (30) |
| 52F226-011-100 | 4.45 (113) | 0.63 (16) | 1.06 (27) | 1.25 (31.75) | 1.26 (32) | 1.30 (33) |
| 52F226-011-200 | 5.12 (130) | 0.75 (19) | | | 1.57 (40) | |
| 52F226-011-250 | 5.83 (148) | | 1.57 (40) | 2 (50.80) | | |
| 52F226-011-300 | | | | | | |
| 52F226-021-16 | 2.95 (75) | 0.47 (12) | 0.67 (17) | 0.75 (19.05) | 0.71 (18) | 1.18 (30) |
| 52F226-021-32 | | | | | | |
| 52F226-021-63 | 3.78 (96) | 0.55 (14) | 0.87 (22) | 1 (25.40) | 1.02 (26) | |
| 52F226-021-100 | 4.45 (113) | 0.63 (16) | 1.06 (27) | 1.25 (31.75) | 1.26 (32) | 1.30 (33) |
| 52F226-021-200 | 5.12 (130) | 0.75 (19) | | | 1.57 (40) | |
| 52F226-021-250 | 6.30 (160) | | 1.57 (40) | 2 (50.80) | | |
| 52F226-021-300 | | | | | | |
| 52F226-031-16 | 2.95 (75) | 0.47 (12) | 0.67 (17) | 0.75 (19.05) | 0.71 (18) | 1.18 (30) |
| 52F226-031-32 | | | | | | |
| 52F226-031-63 | 3.78 (96) | 0.55 (14) | 0.87 (22) | 1 (25.40) | 1.02 (26) | |
| 52F226-031-100 | 4.45 (113) | 0.63 (16) | 1.06 (27) | 1.25 (31.75) | 1.26 (32) | 1.30 (33) |
| 52F226-031-200 | 5.79 (147) | 0.75 (19) | | | 1.57 (40) | |
| 52F226-031-250 | 7.01 (178) | | 1.57 (40) | 2 (50.80) | | |
| 52F226-031-300 | | | | | | |
| 52F226-041-16 | 3.23 (82) | 0.63 (16) | 1.06 (27) | 1.25 (31.75) | 0.71 (18) | 1.30 (33) |
| 52F226-041-32 | | | | | | |
| 52F226-041-63 | 3.98 (101) | 0.75 (19) | 1.57 (40) | 1.5 (38.10) | 1.02 (26) | |
| 52F226-041-100 | 5.24 (133) | | | | 1.26 (32) | 1.97 (50) |
| 52F226-041-200 | 6.50 (165) | 1.57 (40) | 2 (50.80) | 1.57 (40) | | |

Dimensions in inches (mm)

High Current DC Single Line Pi Series



RoHS
COMPLIANT

Features

- Voltage rating of 130VDC
- Pi configuration with Class Y4 capacitors
- Current rating up to 200 Amps
- Excellent filtering in compact package
- Bolt-in style with D-shaped bushing for easy installation
- Low cost EMI solution
- UL and Semko approved

Applications

- Telecommunications (cellular base stations, telephone switching racks, etc.)
- Power supplies
- Medical equipment
- C.O.T.S. (Commercial-Off-The-Shelf) Military
- Industrial equipment controls
- Data transmission equipment

Circuit Diagram

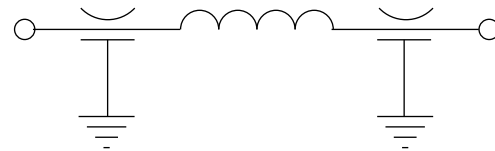

Specifications

| Part Number | Rated Current | Min. Cap. (2X) | Minimum Insertion Loss (db) * | | | | | |
|-----------------------------|---------------|----------------|-------------------------------|--------|------|-------|--------|---------|
| | | | .01MHz | .10MHz | 1MHz | 10MHz | 100MHz | 1000MHz |
| Standard Performance | | | | | | | | |
| 52F226-020-10 | 10A | 10nF | - | 0.5 | 8 | 23 | 70 | 90 |
| 52F226-020-16 | 16A | | | 35 | | | | |
| 52F226-020-32 | 32A | | | 2 | 10 | 23 | 50 | |
| 52F226-020-63 | 63A | 100nF | 8 | 27 | 67 | 90 | | |
| 52F226-020-100 | 100A | 470nF | 4 | 21 | 30 | | 70 | |
| 52F226-020-200 | 200A | | 7 | 23 | 60 | | | |
| High Performance | | | | | | | | |
| 52F226-029-10 | 10A | 100nF | - | 8 | 25 | 75 | 90 | 90 |
| 52F226-029-16 | 16A | | | | | | | |
| 52F226-029-32 | 32A | | | | | | | |
| 52F226-029-63 | 63A | 470nF | 4 | 21 | 35 | 70 | | |
| 52F226-029-100 | 100A | 1000nF | 8 | 26 | 57 | 73 | | |
| 52F226-029-200 | 200A | 4700nF | 20 | 40 | 85 | 90 | | |

* Optimum performance with proper installation

High Current DC Single Line Pi Series

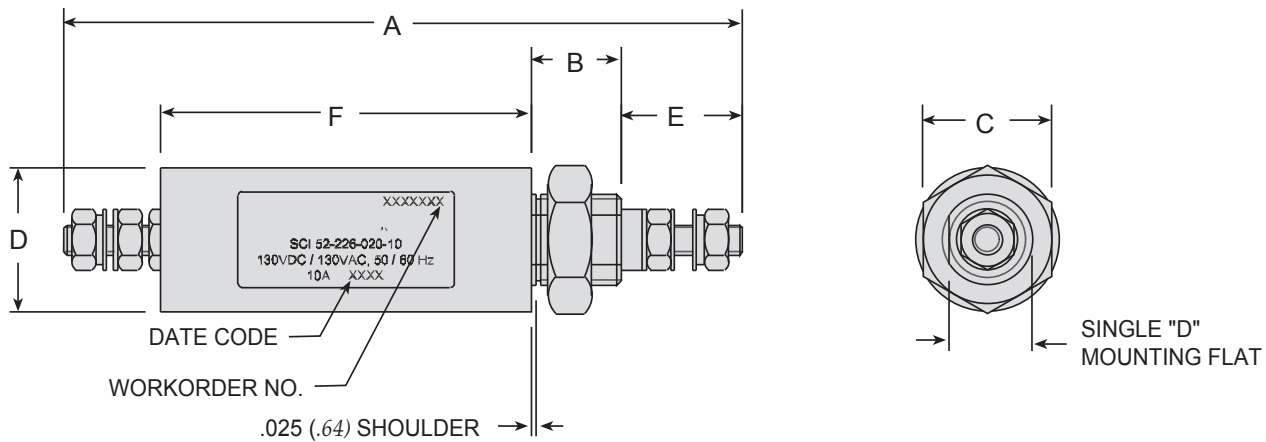

Dimensions

| Part Number | A | B | C | D | E | F |
|-----------------------------|------------|-----------|-----------|--------------|-----------|------------|
| Standard Performance | | | | | | |
| 52F226-020-10 | 3.54 (90) | 0.47 (12) | 0.67 (17) | 0.75 (19.05) | 0.63 (16) | 1.93 (49) |
| 52F226-020-16 | 3.86 (98) | | | | 0.71 (18) | 2.09 (53) |
| 52F226-020-32 | | | | | 1.02 (26) | 3.70 (94) |
| 52F226-020-63 | 6.30 (160) | 0.55 (14) | 0.87 (22) | 1 (25.40) | 1.26 (32) | 4.09 (104) |
| 52F226-020-100 | 7.24 (184) | 0.63 (16) | 1.06 (27) | 1.25 (31.75) | 1.57 (40) | 4.41 (112) |
| 52F226-020-200 | 8.23 (209) | 0.75 (19) | | 1.50 (38.10) | 1.57 (40) | 4.41 (112) |
| High Performance | | | | | | |
| 52F226-029-10 | 5.12 (130) | 0.47 (12) | 0.67 (17) | 0.75 (19.05) | 0.63 (16) | 3.50 (89) |
| 52F226-029-16 | 5.47 (139) | | | | 0.71 (18) | 3.70 (94) |
| 52F226-029-32 | | | | | 1.02 (26) | 4.13 (105) |
| 52F226-029-63 | 6.81 (173) | 0.63 (16) | 1.06 (27) | 1.25 (31.75) | 1.26 (32) | 5.71 (145) |
| 52F226-029-100 | 8.98 (228) | 0.75 (19) | | 1.50 (38.10) | 1.57 (40) | 7.17 (182) |
| 52F226-029-200 | 11 (279) | | 1.57 (40) | 2 (50.80) | 1.57 (40) | 7.17 (182) |

Dimensions in inches (mm)

High Current AC Single Line Feed-through Series



Features

- Voltage rating of 250VAC
- C configuration with Class Y2 capacitors
- Current rating up to 300 Amps
- Excellent filtering in compact package
- Bolt-in style with D-shaped bushing for easy installation
- Low cost EMI solution
- Design flexibility
- UL and Semko approvals pending

Applications

- Telecommunications (cellular base stations, telephone switching racks, etc.)
- Power supplies
- Medical equipment
- C.O.T.S. (Commercial-Off-The-Shelf) Military
- Industrial equipment controls
- Data transmission equipment

RoHS
COMPLIANT

Specifications

| Part Number | Rated Current | Min. Cap. | Minimum Insertion Loss (db) * | | | | | | | | | | | |
|----------------|---------------|-----------|-------------------------------|--------|------|-------|--------|---------|----|----|----|----|----|----|
| | | | .01MHz | .10MHz | 1MHz | 10MHz | 100MHz | 1000MHz | | | | | | |
| 52F226-016-10 | 10A | 2.2nF | - | - | - | 9 | 30 | 45 | | | | | | |
| 52F226-016-16 | 16A | 4.7nF | | | - | 2 | 15 | 34 | 54 | | | | | |
| 52F226-016-32 | 32A | | | | | 4 | 21 | 41 | 60 | | | | | |
| 52F226-016-63 | 63A | 10nF | | 2 | 15 | 34 | 53 | 74 | | | | | | |
| 52F226-016-100 | 100A | 47nF | | | 5 | 21 | 40 | 60 | 85 | | | | | |
| 52F226-016-200 | 200A | 100nF | | | | 2 | 15 | 34 | 53 | 74 | | | | |
| 52F226-016-250 | 250A | | | 10 | | | 27 | 47 | 67 | 90 | | | | |
| 52F226-016-300 | 300A | 220nF | | | - | - | 2 | 15 | 34 | 54 | | | | |
| 52F226-026-10 | 10A | 4.7nF | | - | | | - | 4 | 21 | 41 | 60 | | | |
| 52F226-026-16 | 16A | 10nF | | | | | | 2 | 15 | 34 | 53 | 74 | | |
| 52F226-026-32 | 32A | | | | 21 | 40 | | | 60 | 85 | | | | |
| 52F226-026-63 | 63A | 47nF | | - | - | 10 | 27 | 47 | 67 | | | | | |
| 52F226-026-100 | 100A | 100nF | | | | | | | | 2 | 16 | 33 | 52 | 75 |
| 52F226-026-200 | 200A | 220nF | | | | | | | | | | | | |
| 52F226-026-250 | 250A | | | 470nF | 2 | 15 | 34 | 53 | 74 | | | | | |
| 52F226-026-300 | 300A | 1000nF | - | | | - | 10 | 27 | 47 | 67 | | | | |
| 52F226-036-16 | 16A | 47nF | | 2 | 16 | | | | | | 33 | 52 | 75 | |
| 52F226-036-32 | 32A | 33nF | | | | | | | | | | | | 5 |
| 52F226-036-63 | 63A | 100nF | - | | | - | 10 | 27 | 47 | 67 | | | | |
| 52F226-036-100 | 100A | 220nF | | 2 | 16 | | | | | | 33 | 52 | 75 | |
| 52F226-036-200 | 200A | 470nF | | | | | | | | | | | | 5 |
| 52F226-036-250 | 250A | | 100nF | | | - | 2 | 15 | 34 | 53 | | | | |
| 52F226-036-300 | 300A | 1000nF | | - | - | | | 10 | 27 | 47 | 67 | | | |
| 52F226-046-16 | 16A | 100nF | 2 | | | 16 | 33 | | | | | 52 | 75 | |
| 52F226-046-32 | 32A | 47nF | | | | | | | | | | | | 5 |
| 52F226-046-63 | 63A | 220nF | | - | - | | | 10 | 27 | 47 | 67 | | | |
| 52F226-046-100 | 100A | 470nF | 6 | | | 20 | 40 | | | | | 60 | 85 | |
| 52F226-046-200 | 200A | 1000nF | | | | | | | | | | | | 2 |
| 52F226-046-250 | 250A | | | 470nF | - | | | - | 10 | 27 | 47 | | | |
| 52F226-046-300 | 300A | 1000nF | - | | | - | 10 | | | | | 27 | 47 | 67 |

* Optimum performance with proper installation

High Current AC Single Line Feed-through Series

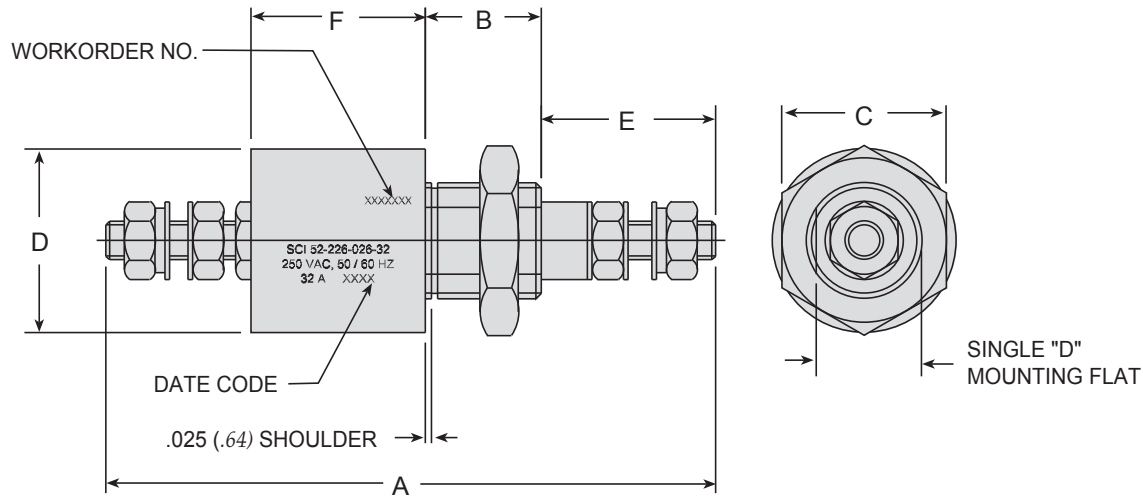

Dimensions

| Part Number | A | B | C | D | E | F | | |
|----------------|------------|-----------|-----------|--------------|-----------|-----------|-----------|-----------|
| 52F226-016-10 | 2.24 (57) | 0.39 (10) | 0.51 (13) | 0.56 (14.29) | 0.63 (16) | 0.71 (18) | | |
| 52F226-016-16 | 2.48 (63) | 0.47 (12) | 0.67 (17) | 0.75 (19.05) | 0.71 (18) | | | |
| 52F226-016-32 | | | | | | | | |
| 52F226-016-63 | 3.78 (96) | 0.55 (14) | 0.87 (22) | 1 (25.40) | 1.02 (26) | 1.18 (30) | | |
| 52F226-016-100 | 4.45 (113) | 0.63 (16) | 1.06 (27) | 1.25 (31.75) | 1.26 (32) | 1.30 (33) | | |
| 52F226-016-200 | 5.12 (130) | | | 1.5 (38.10) | 1.57 (40) | | | |
| 52F226-016-250 | 5.83 (148) | 0.75 (19) | 1.57 (40) | 2 (50.80) | 1.81 (46) | 1.65 (42) | | |
| 52F226-016-300 | | | | | | | | |
| 52F226-026-10 | 2.24 (57) | 0.39 (10) | 0.51 (13) | 0.56 (14.29) | 0.63 (16) | 0.71 (18) | | |
| 52F226-026-16 | 2.48 (63) | 0.47 (12) | 0.67 (17) | 0.75 (19.05) | 0.71 (18) | | | |
| 52F226-026-32 | | | | | | | | |
| 52F226-026-63 | 3.78 (96) | 0.55 (14) | 0.87 (22) | 1 (25.40) | 1.02 (26) | 1.18 (30) | | |
| 52F226-026-100 | 4.45 (113) | 0.63 (16) | 1.06 (27) | 1.25 (31.75) | 1.26 (32) | 1.30 (33) | | |
| 52F226-026-200 | 5.12 (130) | | | 1.5 (38.10) | 1.57 (40) | | | |
| 52F226-026-250 | 5.83 (148) | 0.75 (19) | 1.57 (40) | 2 (50.80) | 1.81 (46) | 1.65 (42) | | |
| 52F226-026-300 | | | | | | | | |
| 52F226-036-16 | 2.95 (75) | 0.47 (12) | 0.67 (17) | 0.75 (19.05) | 0.71 (18) | 1.18 (30) | | |
| 52F226-036-32 | | | | | | | | |
| 52F226-036-63 | 3.78 (96) | 0.55 (14) | 0.87 (22) | 1 (25.40) | 1.02 (26) | | | |
| 52F226-036-100 | 4.57 (116) | 0.75 (19) | 1.06 (27) | 1.5 (38.10) | 1.26 (32) | 1.30 (33) | | |
| 52F226-036-200 | 5.79 (147) | | | | 1.57 (40) | | 1.57 (40) | |
| 52F226-036-250 | 6.30 (160) | | 1.57 (40) | 1.57 (40) | 2 (50.80) | 1.81 (46) | 2.13 (54) | |
| 52F226-036-300 | | | | | | | | |
| 52F226-046-16 | 3.03 (77) | 0.55 (14) | 0.87 (22) | 1 (25.40) | 0.71 (18) | 1.18 (30) | | |
| 52F226-046-32 | 2.95 (75) | 0.47 (12) | 0.67 (17) | | | | | |
| 52F226-046-63 | 4.45 (113) | 0.63 (16) | 1.06 (27) | 1.25 (31.75) | 1.02 (26) | 1.30 (33) | | |
| 52F226-046-100 | 5.24 (133) | | | 1.5 (38.10) | 1.26 (32) | | | |
| 52F226-046-200 | 5.79 (147) | 0.75 (19) | 1.57 (40) | 2 (50.80) | 1.57 (40) | 1.97 (50) | | |
| 52F226-046-250 | 6.30 (160) | | | | 1.57 (40) | | 2 (50.80) | 1.81 (46) |
| 52F226-046-300 | | | | | | | | |

Dimensions in inches (mm)

High Current AC Single Line Pi Series



RoHS
COMPLIANT

Features

- Voltage rating of 250VAC
- Pi configuration with Class Y2 capacitors
- Current rating up to 300 Amps
- Excellent filtering in compact package
- Bolt-in style with D-shaped bushing for easy installation
- Low cost EMI solution
- Design flexibility
- UL and Semko approvals pending

Applications

- Telecommunications (cellular base stations, telephone switching racks, etc.)
- Power supplies
- Medical equipment
- C.O.T.S. (Commercial-Off-The-Shelf) Military
- Industrial equipment controls
- Data transmission equipment

Circuit Diagram

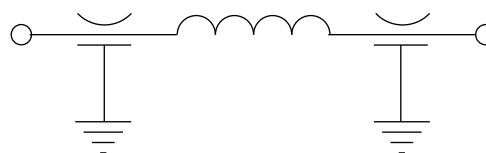

Specifications

| Part Number | Rated Current | Min. Cap. (2X) | Minimum Insertion Loss (db) * | | | | | | | | |
|-----------------------------|---------------|----------------|-------------------------------|--------|------|-------|--------|---------|----|----|----|
| | | | .01MHz | .10MHz | 1MHz | 10MHz | 100MHz | 1000MHz | | | |
| Standard Performance | | | | | | | | | | | |
| 52F226-037-10 | 10A | 4.7nF | - | - | 4 | 19 | 77 | 90 | | | |
| 52F226-037-16 | 16A | 10nF | | 1 | 8 | 22 | 50 | | | | |
| 52F226-037-32 | 32A | | | 4 | 21 | 52 | 80 | | | | |
| 52F226-037-63 | 63A | 47nF | 1 | 8 | 25 | 73 | 90 | | | | |
| 52F226-037-100 | 100A | 100nF | | 9 | 26 | 75 | | | | | |
| 52F226-037-200 | 200A | | | 4 | 21 | 57 | | | 85 | | |
| 52F226-037-250 | 250A | | | | | | | | | | |
| 52F226-037-300 | 300A | | | | | | | | | | |
| High Performance | | | | | | | | | | | |
| 52F226-019-10 | 10A | 10nF | - | 1 | 9 | 30 | 80 | 90 | | | |
| 52F226-019-16 | 16A | 22nF | | 3 | 15 | 47 | | | | | |
| 52F226-019-32 | 32A | | | 1 | 12 | 27 | | | 75 | | |
| 52F226-019-63 | 63A | 150nF | 4 | 21 | 39 | 85 | 90 | | | | |
| 52F226-019-100 | 100A | 470nF | | | 4 | | | | 21 | 57 | 85 |
| 52F226-019-200 | 200A | | | | | | | | | | |
| 52F226-019-250 | 250A | | | | | | | | | | |
| 52F226-019-300 | 300A | | | | | | | | | | |

* Optimum performance with proper installation

High Current AC Single Line Pi Series

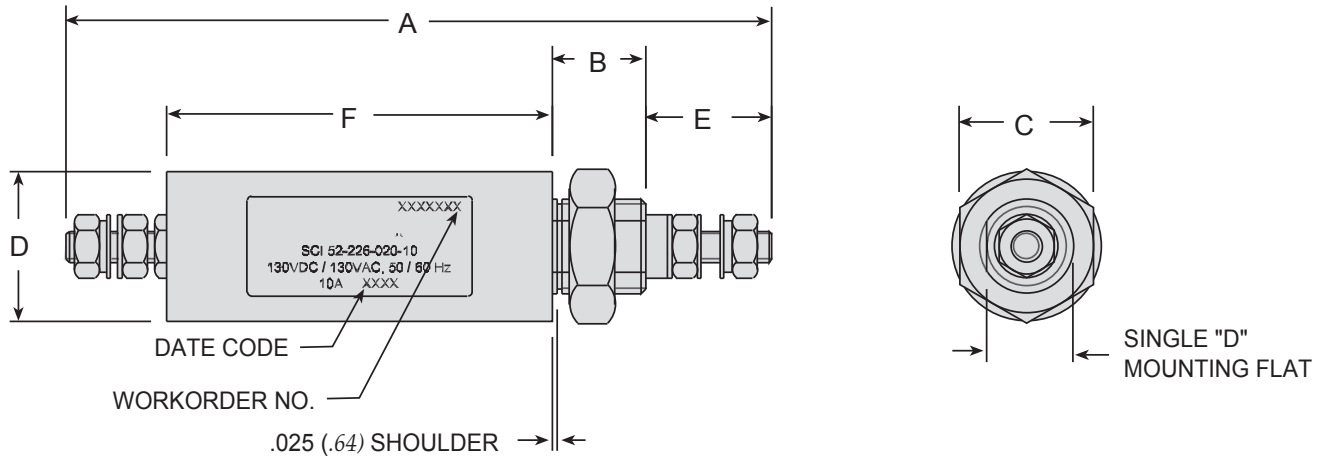

Dimensions

| Part Number | A | B | C | D | E | F |
|-----------------------------|------------|------------|-----------|--------------|-----------|------------|
| Standard Performance | | | | | | |
| 52F226-037-10 | 3.86 (98) | 0.47 (12) | 0.67 (17) | 0.75 (19.05) | 0.63 (16) | 2.24 (57) |
| 52F226-037-16 | 4.17 (106) | | | | 0.71 (18) | 2.40 (61) |
| 52F226-037-32 | | 6.30 (160) | 0.55 (14) | 0.87 (22) | 1 (25.40) | 1.02 (26) |
| 52F226-037-63 | 7.24 (184) | 0.63 (16) | 1.06 (27) | 1.25 (31.75) | 1.26 (32) | 4.09 (104) |
| 52F226-037-100 | 8.23 (209) | 0.75 (19) | | | 1.57 (40) | 1.57 (40) |
| 52F226-037-200 | 7.87 (200) | | 1.57 (40) | 1.5 (38.10) | | 1.81 (46) |
| 52F226-037-250 | | | | | | |
| 52F226-037-300 | | | | | | |
| High Performance | | | | | | |
| 52F226-019-10 | 4.21 (107) | 0.47 (12) | 0.67 (17) | 0.75 (19.05) | 0.63 (16) | 2.6 (66) |
| 52F226-019-16 | 4.57 (116) | 0.55 (14) | 0.87 (22) | 1 (25.40) | 0.71 (18) | 2.72 (69) |
| 52F226-019-32 | | | | | | |
| 52F226-019-63 | 6.81 (173) | 0.63 (16) | 1.06 (27) | 1.25 (31.75) | 1.02 (26) | 4.13 (105) |
| 52F226-019-100 | 8.98 (228) | 0.75 (19) | | | | |
| 52F226-019-200 | 9.57 (243) | | 1.57 (40) | 2 (50.80) | 1.57 (40) | 6.30 (160) |
| 52F226-019-250 | 10.5 (267) | | | | | |
| 52F226-019-300 | | | | | | |

Dimensions in inches (mm)

High Current Filtered Terminal Blocks

Features

- Ideal for high current applications
- Design flexibility
- Available in 2 x 2 through 2 x 6 positions
- UL approved

Applications

- Telecommunications switching networks
- Cellular base stations
- Power supplies
- UPS
- Instrumentation
- High reliability radar and transmission systems
- Industrial controls
- Power distribution

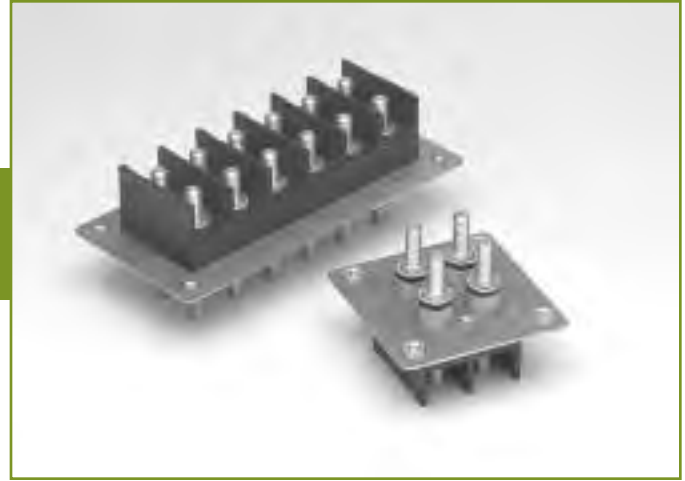

Specifications

ELECTRICAL

Voltage rating: 100 VDC per terminal
Capacitance: .015µF* +80% / -20% per cap
 .030µF +80% / -20% per pair

Dielectric withstanding voltage: 1000VDC for 1 minute
Current rating: 60 Amps max per terminal

| Typical Insertion Loss — dB: In 50 Ohm Circuit | | |
|---|----|-----------------|
| 1 MHz..... | 8 | 70 MHz..... 36 |
| 5 MHz..... | 24 | 100 MHz..... 33 |
| 10 MHz..... | 32 | 160 MHz..... 25 |
| 50 MHz..... | 38 | 200 MHz..... 25 |

MECHANICAL

Center spacing: US .200: (5.08 mm)
Wire size: AWG #12-26
Screw material: Steel, zinc chromate plate
Recommended PCB hole diameter: .05" (1.30 mm) contact hole
Molded material: UL rated 94VO polyamide
Tightening torque: 2.5 in.-lbs. max. (28 Ncm)
Terminal: Brass, tin-plated

* For filter elements with additional capacitance values, consult factory.

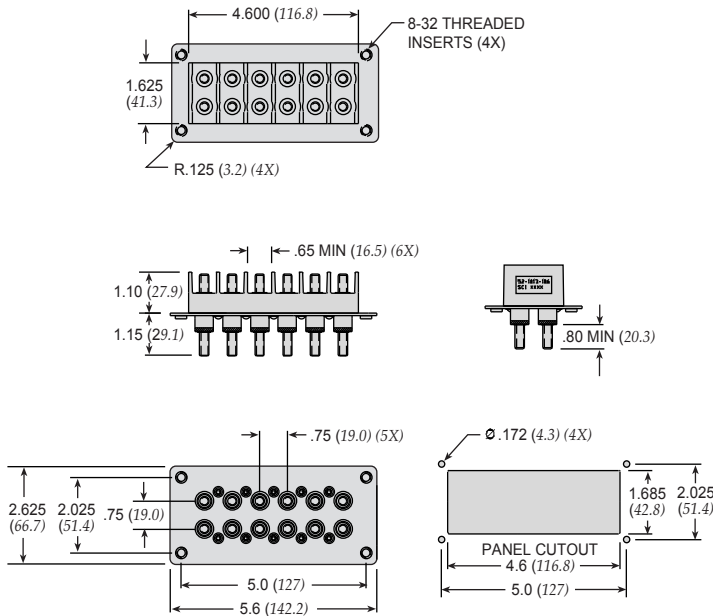

| Part Number | Number of Terminals | A | | B | | C | |
|-------------|---------------------|------|--------|------|--------|------|--------|
| | | in. | (mm) | in. | (mm) | in. | (mm) |
| 52-1013-102 | 2x2 | 2.60 | 66.04 | 2.00 | 50.80 | 1.66 | 42.16 |
| 52-1013-103 | 2x3 | 3.35 | 85.09 | 2.75 | 69.85 | 2.41 | 61.21 |
| 52-1013-104 | 2x4 | 4.10 | 104.14 | 3.50 | 88.90 | 3.16 | 80.25 |
| 52-1013-105 | 2x5 | 4.85 | 123.19 | 4.25 | 107.95 | 3.91 | 99.31 |
| 52-1013-106 | 2x6 | 5.60 | 142.24 | 5.00 | 127.00 | 4.66 | 118.36 |

Dimensions in inches (mm)

Power Entry Modules Bolt-in Rear Terminals

60-BPR & BPS Series

Features

- Ideally suited for products that must conform to FCC part 15 regulations
- Metal case offers high performance
- Meets over voltage of IEC 664 category II and complies with IEC 950
- Uses IEC connector that meets most safety standards
- Solder lug and Fast-on tab terminals available
- Operating temperature: -25°C to +85°C (including temperature rise, see graph on page PF17)
- UL approved low leakage version also available

Applications

- Digital equipment
- Personal computers and peripherals
- Measuring instruments
- Monitor and display units



Tested and found to be IAW VDE 0565 Part 3.



Circuit Diagram

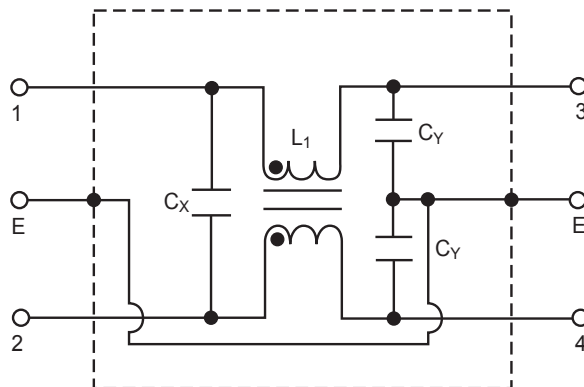

Specifications

| Model* | Rated Voltage (@ 50/60Hz) | Rated Current | Leakage Current (Max.) | Capacitance | | Inductance (L ₁) | Temperature Rise (Max.) |
|-----------------|---------------------------|---------------|------------------------|----------------|----------------|------------------------------|-------------------------|
| | | | | C _Y | C _X | | |
| 60-XXX-010-3-2 | 250VAC | 1A | 0.35mA | 2200pF ± 20% | .022uF ± 20% | 6.0mH | 30°C |
| 60-XXX-010-3-4 | | | | | .047uF ± 20% | | |
| 60-XXX-010-5-2 | | | 0.50mA | 3300pF ± 20% | .022uF ± 20% | | |
| 60-XXX-010-5-4 | | | | | .047uF ± 20% | | |
| 60-XXX-020-3-2 | 250VAC | 2A | 0.35mA | 2200pF ± 20% | .022uF ± 20% | 2.4mH | 30°C |
| 60-XXX-020-3-4 | | | | | .047uF ± 20% | | |
| 60-XXX-020-5-2 | | | 0.50mA | 3300pF ± 20% | .022uF ± 20% | | |
| 60-XXX-020-5-4 | | | | | .047uF ± 20% | | |
| 60-XXX-030-3-2 | 250VAC | 3A | 0.35mA | 2200pF ± 20% | .022uF ± 20% | 1.2mH | 30°C |
| 60-XXX-030-3-4 | | | | | .047uF ± 20% | | |
| 60-XXX-030-5-2 | | | 0.50mA | 3300pF ± 20% | .022uF ± 20% | | |
| 60-XXX-030-5-4 | | | | | .047uF ± 20% | | |
| 60-XXX-060-3-2 | 250VAC | 6A | 0.35mA | 2200pF ± 20% | .022uF ± 20% | 0.53mH | 45°C |
| 60-XXX-060-3-4 | | | | | .047uF ± 20% | | |
| 60-XXX-060-5-2 | | | 0.50mA | 3300pF ± 20% | .022uF ± 20% | | |
| 60-XXX-060-5-4 | | | | | .047uF ± 20% | | |
| 60-XXX-100-3-2 | 250VAC | 10A | 0.35mA | 2200pF ± 20% | .022uF ± 20% | 0.26mH | 45°C |
| 60-XXX-100-5-2 | | | 0.50mA | 3300pF ± 20% | .022uF ± 20% | | |
| 60-BPR-150-3-11 | 250VAC | 15A | 0.35mA | 2200pF ± 20% | .1uF ± 20% | 0.15mH | 45°C |

Note: Test voltage: 1500VAC one minute, line to ground
 Insulation resistance: 300 Mohm min. at 500VDC
 Voltage drop: 1V max. at rated current
 Weight: 45g
 Input: Compatible with IEC-320

* Substitute BPR or BPS for XXX

BPS - Solder lug terminals
 BPR - Fast-on tab terminals

Power Entry Modules Bolt-in Rear Terminals

60-BPR & BPS Series

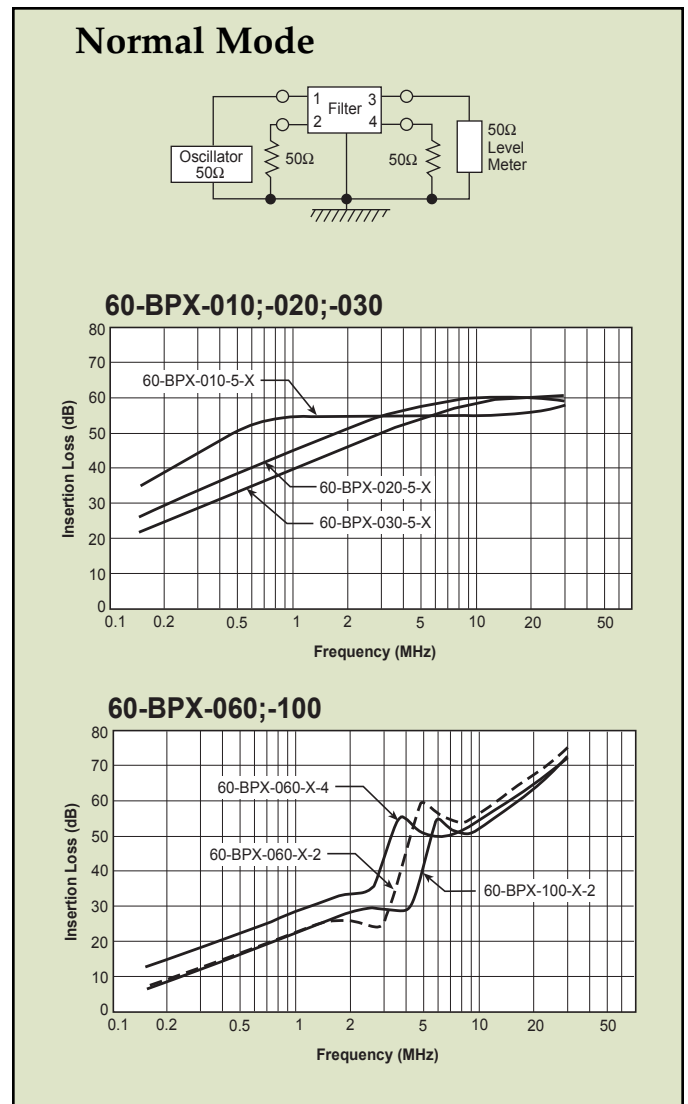
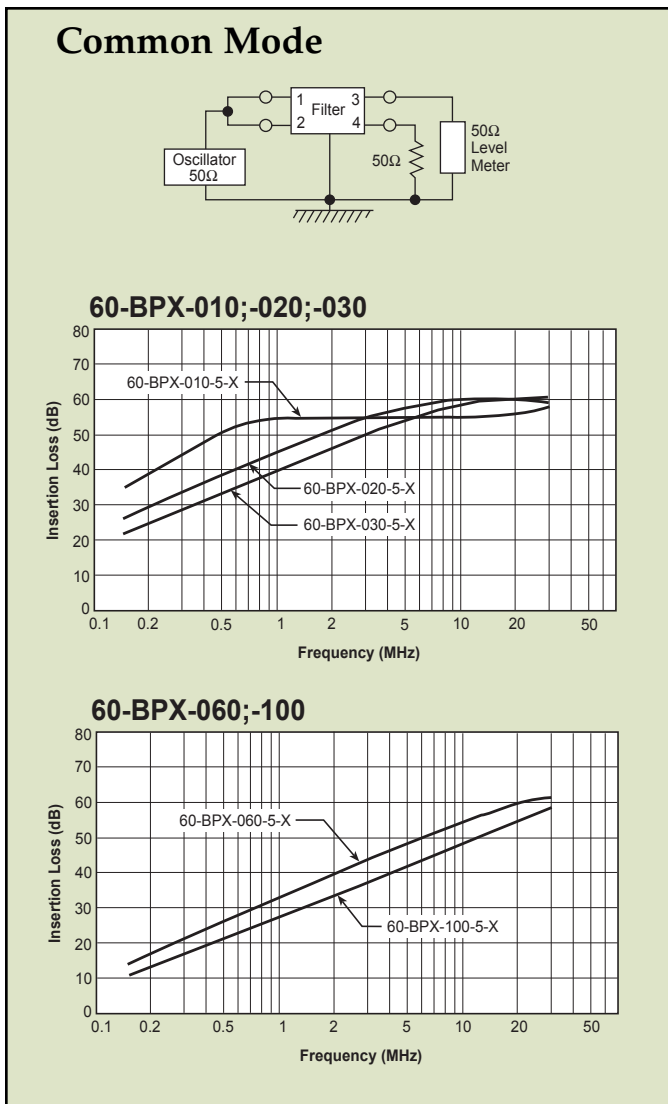
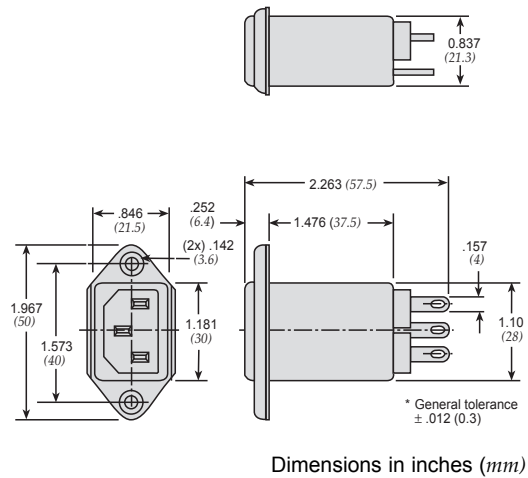
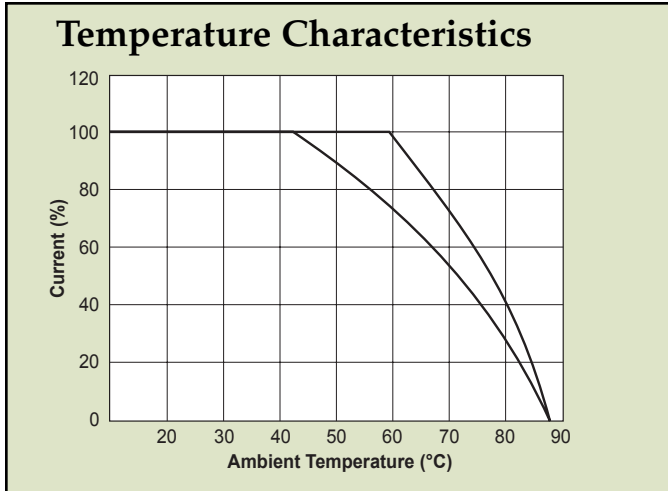

Power Entry Modules Bolt-in Right Angle Terminals



60-BPF Series

Features

- Ideally suited for products that must conform to FCC part 15 regulations
- Metal case offers high performance
- Meets over voltage of IEC 664 category II and complies with IEC 950
- Uses IEC connector that meets most safety standards
- PCB mounting types available (see page PF46)
- Length under tab is shortened for small spaces
- Operating temperature: -25°C to +85°C (including temperature rise, see graph on page PF19)
- UL approved low leakage version also available



Tested and found to be IAW VDE 0565 Part 3.

Applications

- Digital equipment
- Personal computers and peripherals
- Measuring instruments
- Monitor and display units

Circuit Diagram

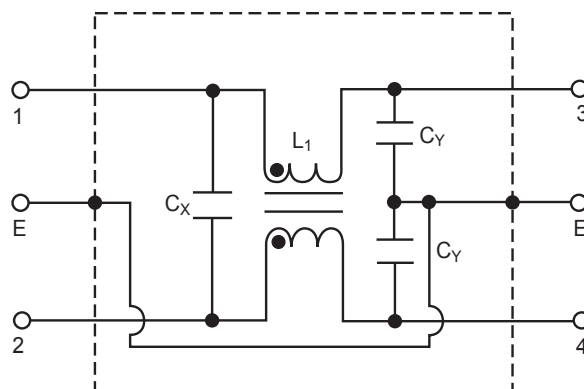

Specifications

| Model | Rated Voltage (@ 50/60Hz) | Rated Current | Leakage Current (Max.) | Capacitance | | Inductance (L ₁) | Temperature Rise (Max.) |
|----------------|---------------------------|---------------|------------------------|----------------|----------------|------------------------------|-------------------------|
| | | | | C _Y | C _X | | |
| 60-BPF-010-3-2 | 250VAC | 1A | 0.35mA | 2200pF ± 20% | .022uF ± 20% | 6.0mH | 30°C |
| 60-BPF-010-3-4 | | | | | .047uF ± 20% | | |
| 60-BPF-010-5-2 | | | 0.50mA | 3300pF ± 20% | .022uF ± 20% | | |
| 60-BPF-010-5-4 | | | | | .047uF ± 20% | | |
| 60-BPF-020-3-2 | 250VAC | 2A | 0.35mA | 2200pF ± 20% | .022uF ± 20% | 2.4mH | 30°C |
| 60-BPF-020-3-4 | | | | | .047uF ± 20% | | |
| 60-BPF-020-5-2 | | | 0.50mA | 3300pF ± 20% | .022uF ± 20% | | |
| 60-BPF-020-5-4 | | | | | .047uF ± 20% | | |
| 60-BPF-030-3-2 | 250VAC | 3A | 0.35mA | 2200pF ± 20% | .022uF ± 20% | 1.2mH | 30°C |
| 60-BPF-030-3-4 | | | | | .047uF ± 20% | | |
| 60-BPF-030-5-2 | | | 0.50mA | 3300pF ± 20% | .022uF ± 20% | | |
| 60-BPF-030-5-4 | | | | | .047uF ± 20% | | |
| 60-BPF-060-3-2 | 250VAC | 6A | 0.35mA | 2200pF ± 20% | .022uF ± 20% | 0.53mH | 45°C |
| 60-BPF-060-3-4 | | | | | .047uF ± 20% | | |
| 60-BPF-060-5-2 | | | 0.50mA | 3300pF ± 20% | .022uF ± 20% | | |
| 60-BPF-060-5-4 | | | | | .047uF ± 20% | | |

Note: Test voltage: 1500VAC one minute, line to ground
 Insulation resistance: 300 Mohm min. at 500VDC
 Voltage drop: 1V max. at rated current
 Weight: 50g
 Input: Compatible with IEC-320

Power Entry Modules Bolt-in Right Angle Terminals

60-BPF Series

Temperature Characteristics

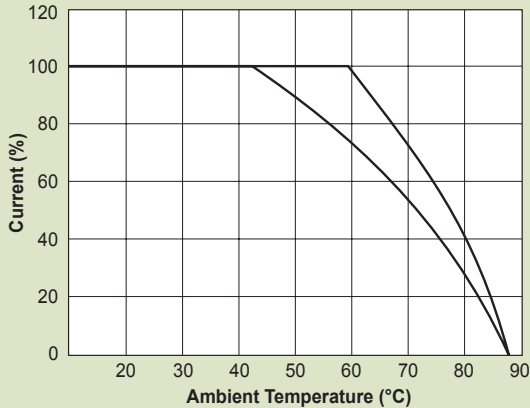

60-BPF Fast-on Terminals

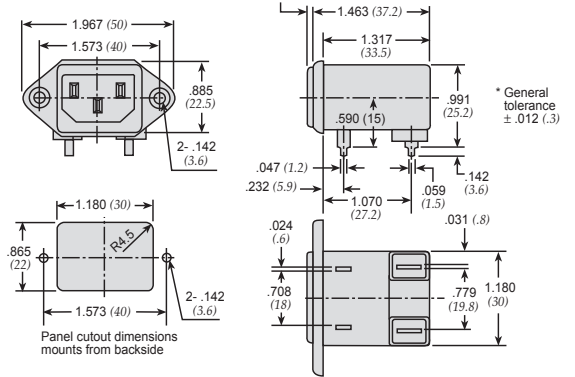

Dimensions in inches (mm)

Common Mode

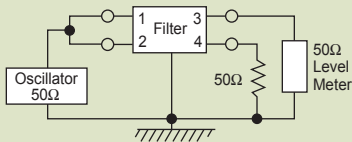

60-BPF-010;-020

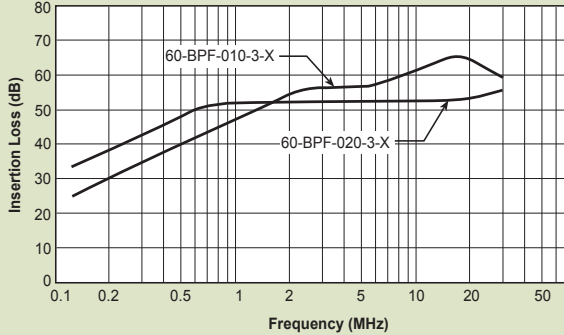

60-BPF-030;-060

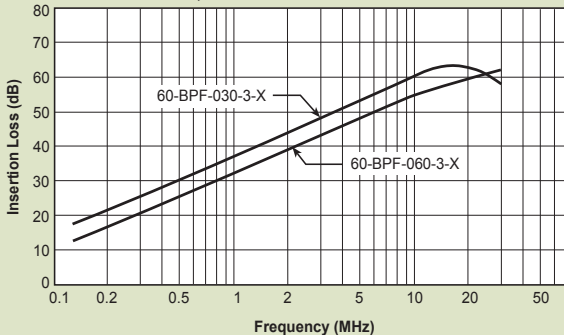

Normal Mode

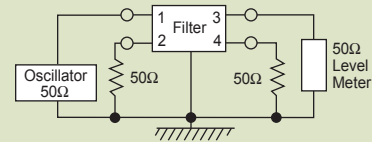

60-BPF-010;-020

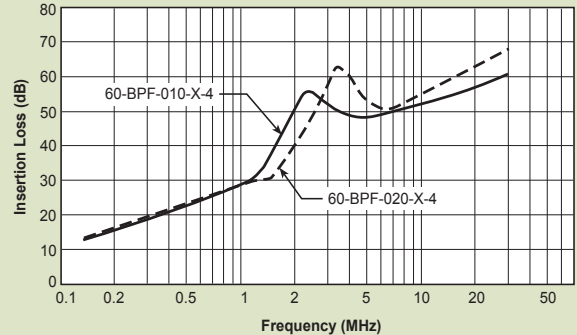

60-BPF-030;-060

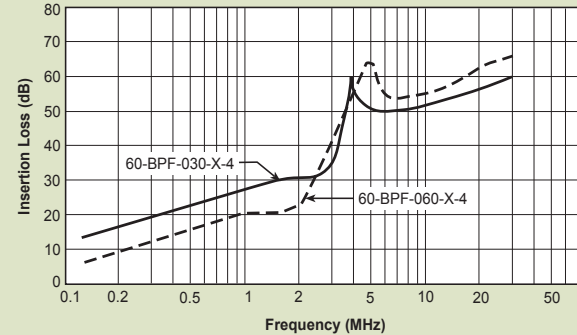

Power Entry Modules High Frequency Attenuation

60-BHS Series

Features

- Ideally suited for products that must conform to FCC part 15 regulations
- Metal cased miniature filter offers high performance
- Meets over voltage of IEC 664 category II and complies with IEC 950
- PCB mounting types available (see page PF48)
- PCB mounting minimizes space and provides economical installation
- Excellent filtering characteristics for high frequencies
- Earth coil standard
- Operating temperature: -25°C to +85°C (including temperature rise, see graph on page PF21)

Applications

- Digital equipment
- Personal computers and peripherals
- Measuring instruments
- Monitor and display units



Tested and found to be IAW VDE 0565 Part 3.



Circuit Diagram

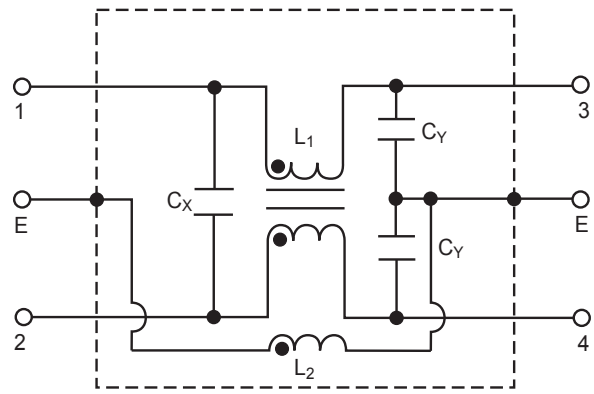

Specifications

| Model | Rated Voltage (@ 50/60Hz) | Rated Current | Leakage Current (Max.) | Capacitance | | Inductance (L ₁) (L ₂) | | Temperature Rise (Max.) |
|-----------------|---------------------------|---------------|------------------------|----------------|----------------|--|-------------------|-------------------------|
| | | | | C _Y | C _X | (L ₁) | (L ₂) | |
| 60-BHS-010-3-11 | 250VAC | 1A | 0.35mA | 2200pF ± 20% | 0.1uF ± 20% | 6mH | 18.3uH | 30°C |
| 60-BHS-010-3-4 | | | | | .047uF ± 20% | | | |
| 60-BHS-010-5-11 | | | 0.50mA | 3300pF ± 20% | 0.1uF ± 20% | | | |
| 60-BHS-010-5-4 | | | | | .047uF ± 20% | | | |
| 60-BHS-020-3-11 | 250VAC | 2A | 0.35mA | 2200pF ± 20% | 0.1uF ± 20% | 2.4mH | 18.3uH | 30°C |
| 60-BHS-020-3-4 | | | | | .047uF ± 20% | | | |
| 60-BHS-020-5-11 | | | 0.50mA | 3300pF ± 20% | 0.1uF ± 20% | | | |
| 60-BHS-020-5-4 | | | | | .047uF ± 20% | | | |
| 60-BHS-030-3-11 | 250VAC | 3A | 0.35mA | 2200pF ± 20% | 0.1uF ± 20% | 1.2mH | 18.3uH | 30°C |
| 60-BHS-030-3-4 | | | | | .047uF ± 20% | | | |
| 60-BHS-030-5-11 | | | 0.50mA | 3300pF ± 20% | 0.1uF ± 20% | | | |
| 60-BHS-030-5-4 | | | | | .047uF ± 20% | | | |
| 60-BHS-060-3-11 | 250VAC | 6A | 0.35mA | 2200pF ± 20% | 0.1uF ± 20% | .53mH | 18.3uH | 45°C |
| 60-BHS-060-3-4 | | | | | .047uF ± 20% | | | |
| 60-BHS-060-5-11 | | | 0.50mA | 3300pF ± 20% | 0.1uF ± 20% | | | |
| 60-BHS-060-5-4 | | | | | .047uF ± 20% | | | |

Note: Test voltage: 1500VAC one minute, line to ground
 Insulation resistance: 300 Mohm min. at 500VDC
 Voltage drop: 1V max. at rated current
 Weight: 50g
 Input: Compatible with IEC-320

Power Entry Modules High Frequency Attenuation

60-BHS Series

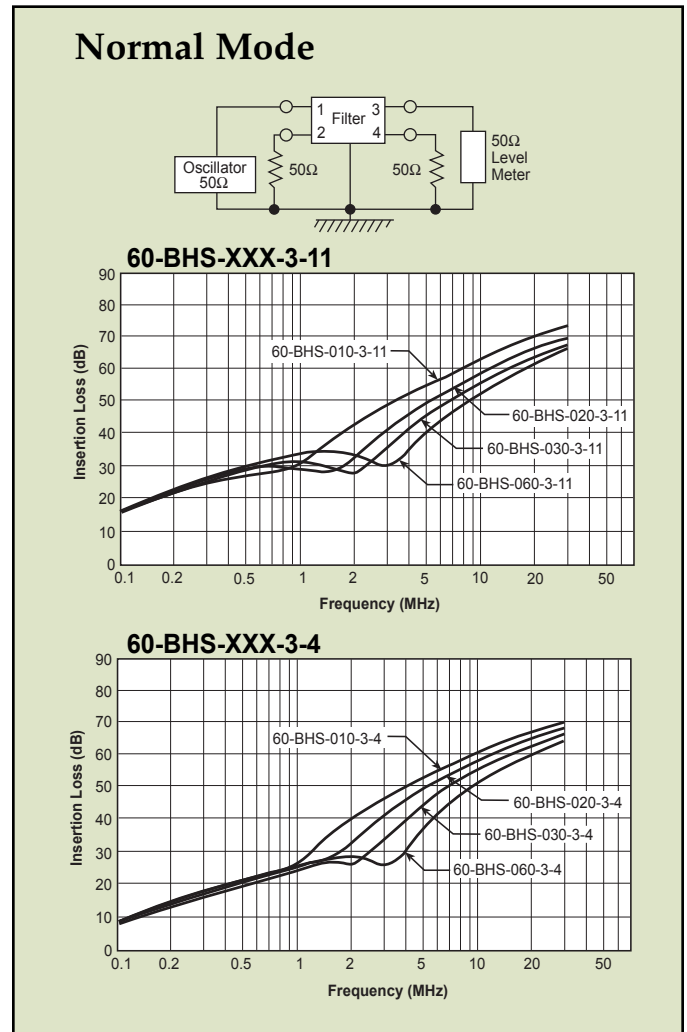
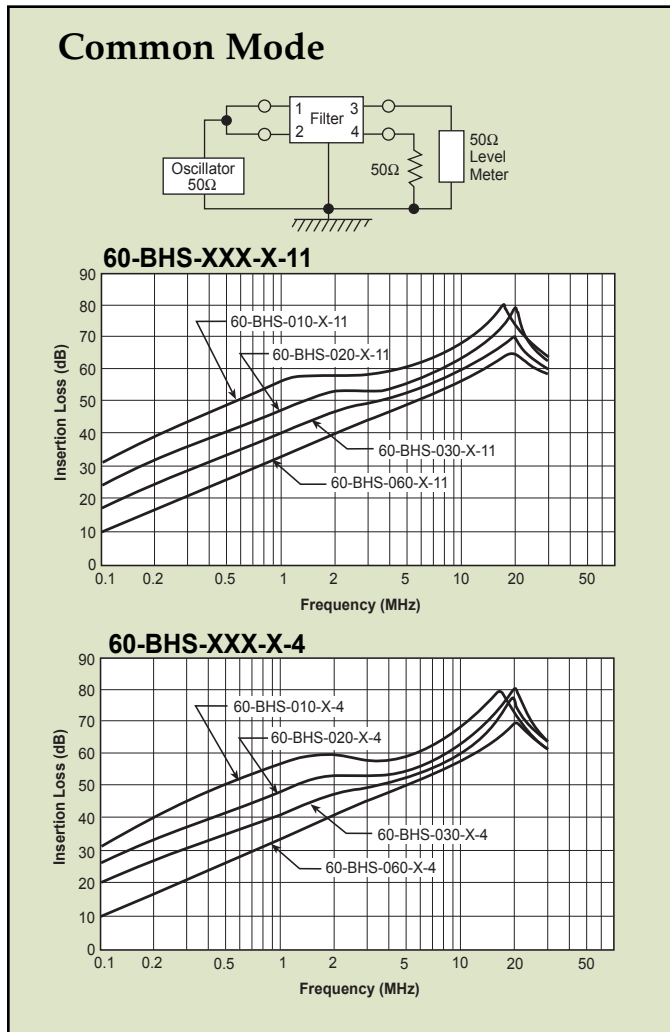
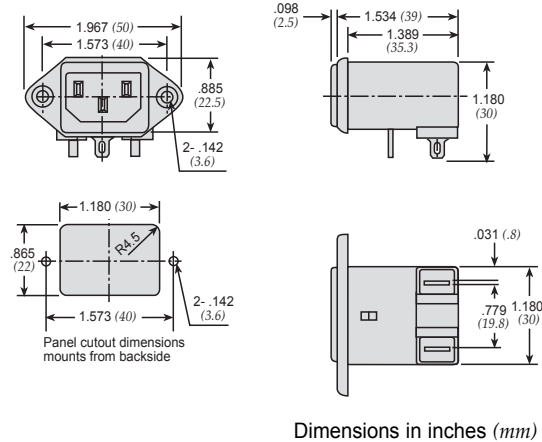
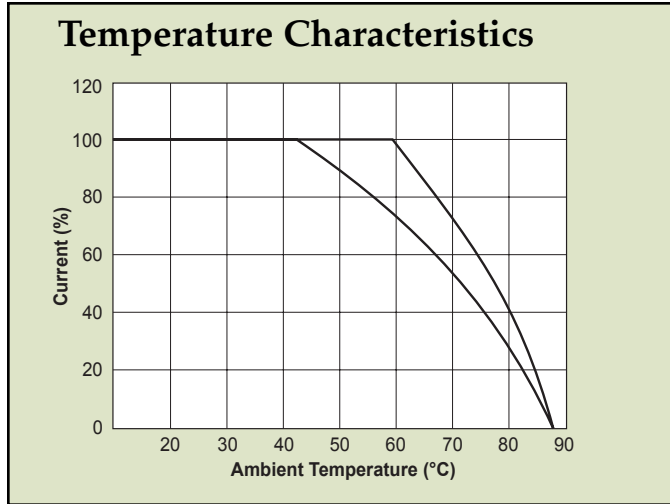

Power Entry Modules Bolt-in Rear Terminals

For General Purpose Applications



10-BPF Series



Features

- Ideally suited for products that must conform to FCC part 15 regulations
- Metal case offers high performance
- Meets over voltage of IEC 664 category II and complies with IEC 950
- Uses IEC connector that meets most safety standards
- Operating temperature: -25°C to +70°C
- Compact configuration

Applications

- Digital equipment
- Personal computers and peripherals
- Measuring instruments
- Monitor and display units

Circuit Diagram

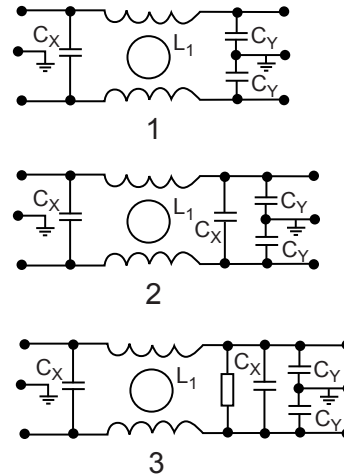

Specifications

| Model | Rated Voltage (@ 50/60Hz) | Rated Current | Leakage Current (Max.) | Capacitance | | Inductance (L ₁) | Circuit Diagram | Figure | Temperature Rise (Max.) |
|----------------|---------------------------|---------------|------------------------|-----------------|-----------------|------------------------------|-----------------|-----------------|-------------------------|
| | | | | C _Y | C _X | | | | |
| 10-BPF-001-5-A | 120/250VAC | 1A | 0.50mA | 3300pF | 2200pF | 3.0mH | 1 | A | 30°C |
| 10-BPF-001-5-C | | | | | | | | C | |
| 10-BPF-003-5-A | | 3A | | 4700pF | 0.01uF | 1.5mH | 2 | A | |
| 10-BPF-003-5-C | | | | | | | | C | |
| 10-BPF-003-5-D | | 6A | | 3300pF | 0.5mH | 1 | A | | |
| 10-BPF-006-5-A | | | | | | | C | | |
| 10-BPF-006-5-C | | 10A | | 3300pF & 0.01uF | 3300pF & 0.01uF | 1.5mH | 2 | B | |
| 10-BPF-006-5-D | | | | | | | | B | |
| 10-BPF-010-5-A | | 3300pF | | 0.01uF | 0.5mH | 1 | A | | |
| 10-BPF-010-5-D | | | | | | | 3300pF & 0.01uF | 3300pF & 0.01uF | |

Note: Test voltage: 1500VAC one minute, line to ground
 Insulation resistance: 300 Mohm min. at 500VDC
 Voltage drop: 1V max. at rated current
 Weight: 45g
 Input: Compatible with IEC-320

Power Entry Modules Bolt-in Rear Terminals For General Purpose Applications

10-BPF Series

Figure A

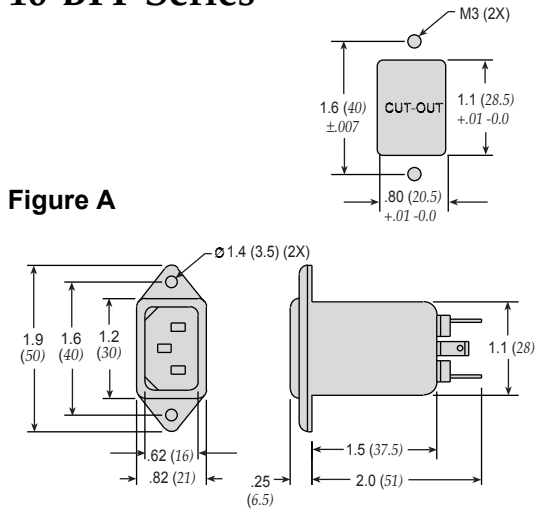

Figure B

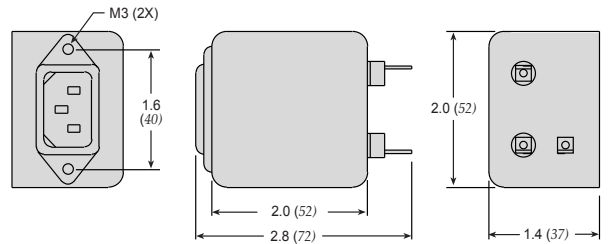
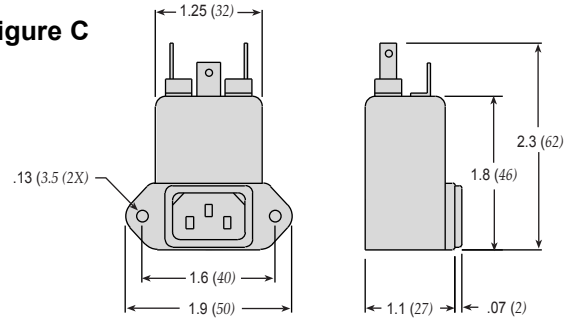
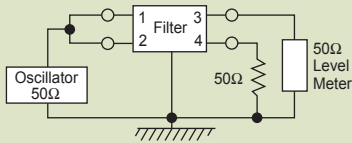

Figure C



Dimensions in inches (mm)

Common Mode



10-BPF-001;-003

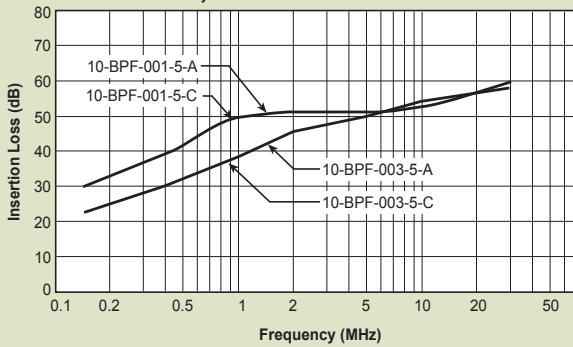

10-BPF-006;-010

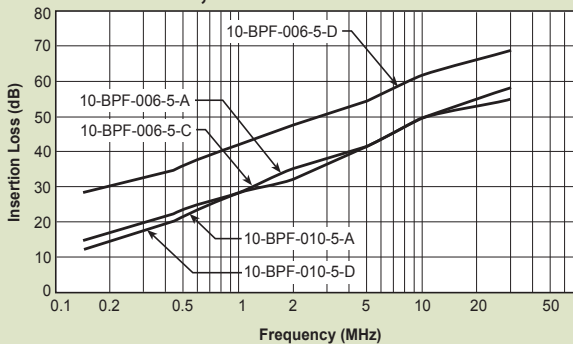

Normal Mode

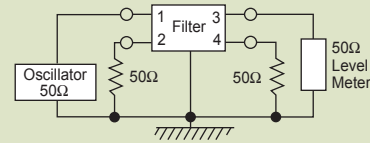

10-BPF-001;-003

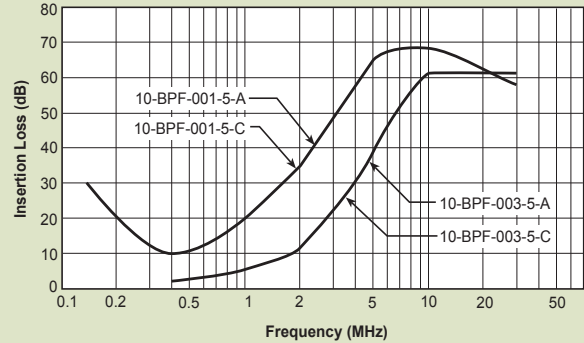

10-BPF-006;-010

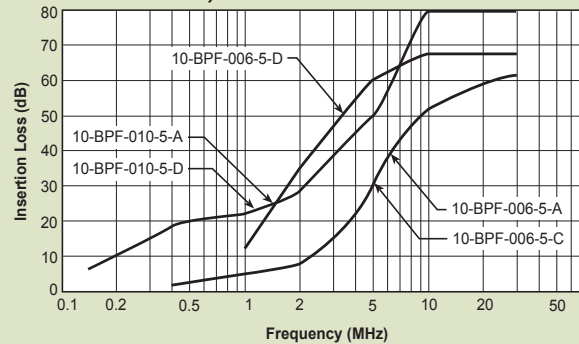

Power Entry Modules Bolt-in Rear Terminals

For Medical Purpose Applications



10-BPF Series



Features

- Ideally suited for products that must conform to FCC part 15 regulations
- Metal case offers high performance
- Meets over voltage of IEC 664 category II and complies with IEC 950
- Uses IEC connector that meets most safety standards
- Operating temperature: -25°C to +70°C
- Compact configuration
- Low leakage current

Applications

- Digital equipment
- Personal computers and peripherals
- Measuring instruments
- Monitor and display units

Circuit Diagram

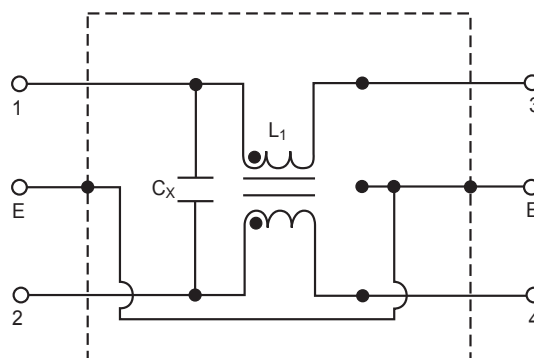

Specifications

| Model | Rated Voltage (@ 50/60Hz) | Rated Current | Leakage Current (Max.) | Capacitance C _x | Inductance (L ₁) | Circuit Diagram | Figure | Temperature Rise (Max.) |
|----------------|---------------------------|---------------|------------------------|----------------------------|------------------------------|-----------------|--------|-------------------------|
| 10-BPF-001-2-A | 120/250VAC | 1A | 5uA | 0.01uF | 3.0mH | 1 | A | 30°C |
| 10-BPF-003-2-A | | 3A | | | 1.5mH | | | |
| 10-BPF-006-2-A | | 6A | | | 0.5mH | | | |

Note: Test voltage: 1500VAC one minute, line to ground
 Insulation resistance: 300 Mohm min. at 500VDC
 Voltage drop: 1V max. at rated current
 Weight: 45g
 Input: Compatible with IEC-320

Power Entry Modules Bolt-in Rear Terminals For Medical Purpose Applications

10-BPF Series

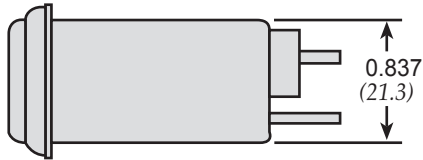

Dimensions in inches (mm)

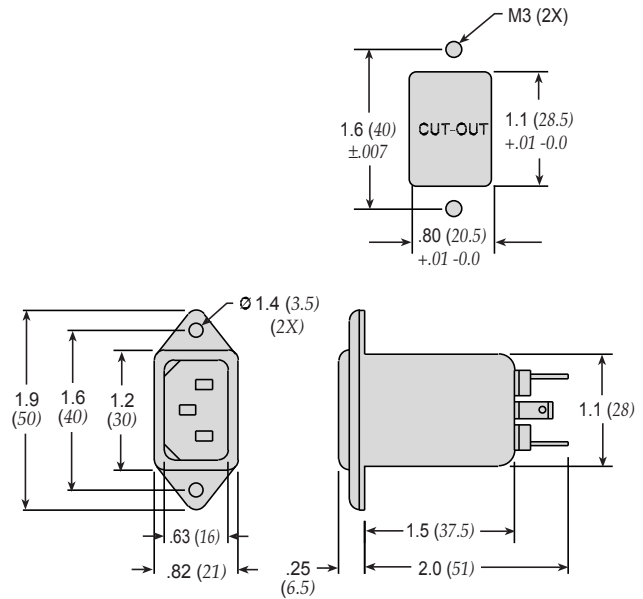

Common Mode

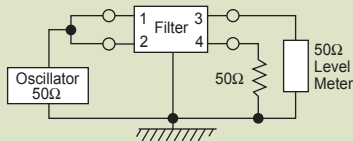

10-BPF-001;-003;-006

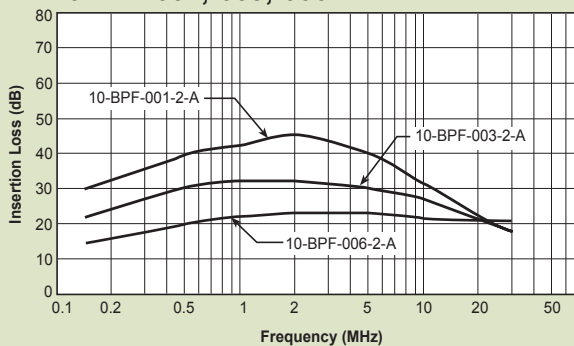

Normal Mode

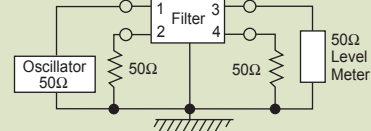

10-BPF-001;-003;-006

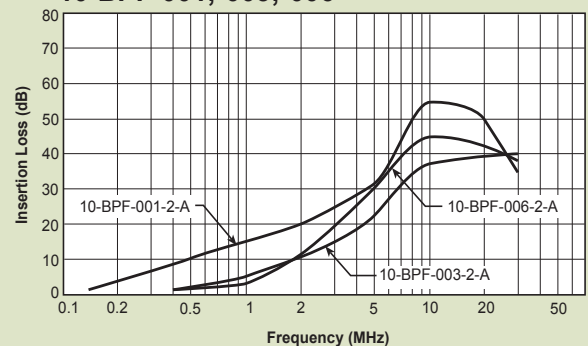

Power Entry Modules Bolt-in with Wire Leads



60-SPL Series

Features

- Ideally suited for products that must conform to FCC part 15 regulations
- Metal cased miniature filter offers high performance
- Meets over voltage of IEC 664 category II and complies with IEC 950
- Uses IEC connector that meets most safety standards
- Snap-in style saves labor and hardware inventory
- Wire output minimizes space and provides economical installation
- Operating temperature: -25°C to +85°C (including temperature rise, see graph on page PF27)



Tested and found to be IAW VDE 0565 Part 3.

Applications

- Digital equipment
- Personal computers and peripherals
- Measuring instruments
- Monitor and display units

Circuit Diagram

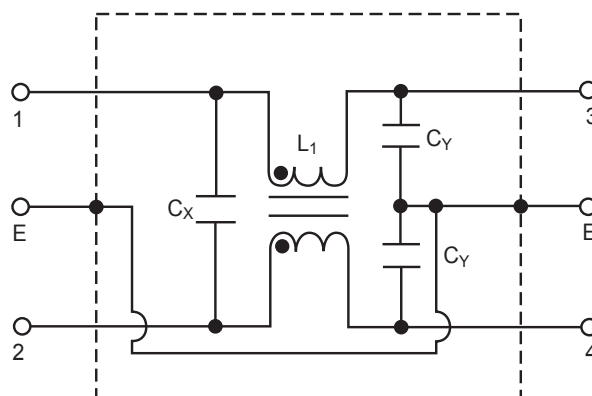

Specifications

| Model | Rated Voltage (@ 50/60Hz) | Rated Current | Leakage Current (Max.) | Capacitance | | Inductance (L ₁) | Temperature Rise (Max.) | |
|----------------|---------------------------|---------------|------------------------|----------------|----------------|------------------------------|-------------------------|--------------|
| | | | | C _Y | C _X | | | |
| 60-SPL-010-3-2 | 250VAC | 1A | 0.35mA | 2200pF ± 20% | 22nF ± 20% | 6.0mH | 30°C | |
| 60-SPL-010-3-3 | | | | | 33nF ± 20% | | | |
| 60-SPL-010-5-2 | | | 0.50mA | 3300pF ± 20% | 22nF ± 20% | | | |
| 60-SPL-010-5-3 | | | | | 33nF ± 20% | | | |
| 60-SPL-020-3-2 | 250VAC | 2A | 0.35mA | 2200pF ± 20% | 22nF ± 20% | 2.4mH | 30°C | |
| 60-SPL-020-3-3 | | | | | 33nF ± 20% | | | |
| 60-SPL-020-5-2 | | | 0.50mA | 3300pF ± 20% | 22nF ± 20% | | | |
| 60-SPL-020-5-3 | | | | | 33nF ± 20% | | | |
| 60-SPL-030-3-2 | 250VAC | 3A | 0.35mA | 2200pF ± 20% | .022uF ± 20% | 1.2mH | 30°C | |
| 60-SPL-030-3-3 | | | | 3300pF ± 20% | | | | |
| 60-SPL-030-5-2 | | | 0.50mA | 3300pF ± 20% | 2200pF ± 20% | | | .033uF ± 20% |
| 60-SPL-030-5-3 | | | | | 3300pF ± 20% | | | |
| 60-SPL-060-3-2 | 250VAC | 6A | 0.35mA | 2200pF ± 20% | 22nF ± 20% | 0.53mH | 45°C | |
| 60-SPL-060-3-3 | | | | | 33nF ± 20% | | | |
| 60-SPL-060-5-2 | | | 0.50mA | 3300pF ± 20% | 22nF ± 20% | | | |
| 60-SPL-060-5-3 | | | | | 33nF ± 20% | | | |

Note: Test voltage: 1500VAC one minute, line to ground
 Insulation resistance: 300 Mohm min. at 500VDC
 Voltage drop: 1V max. at rated current
 Weight: 50g
 Input: Compatible with IEC-320

Power Entry Modules Snap-in with Wire Leads

60-SPL Series

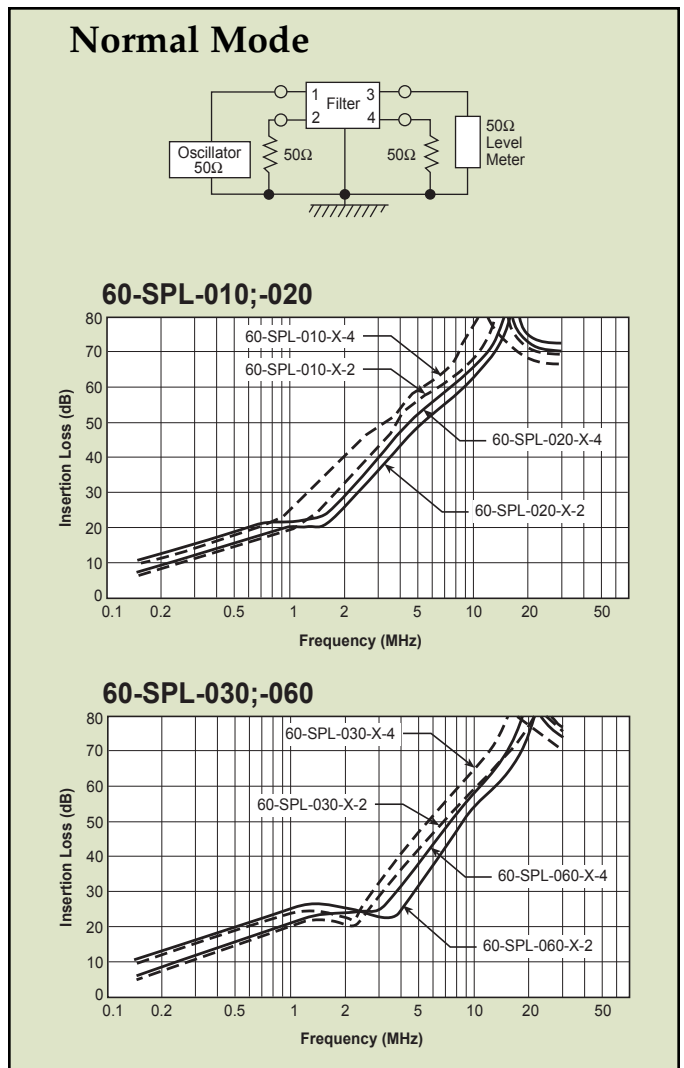
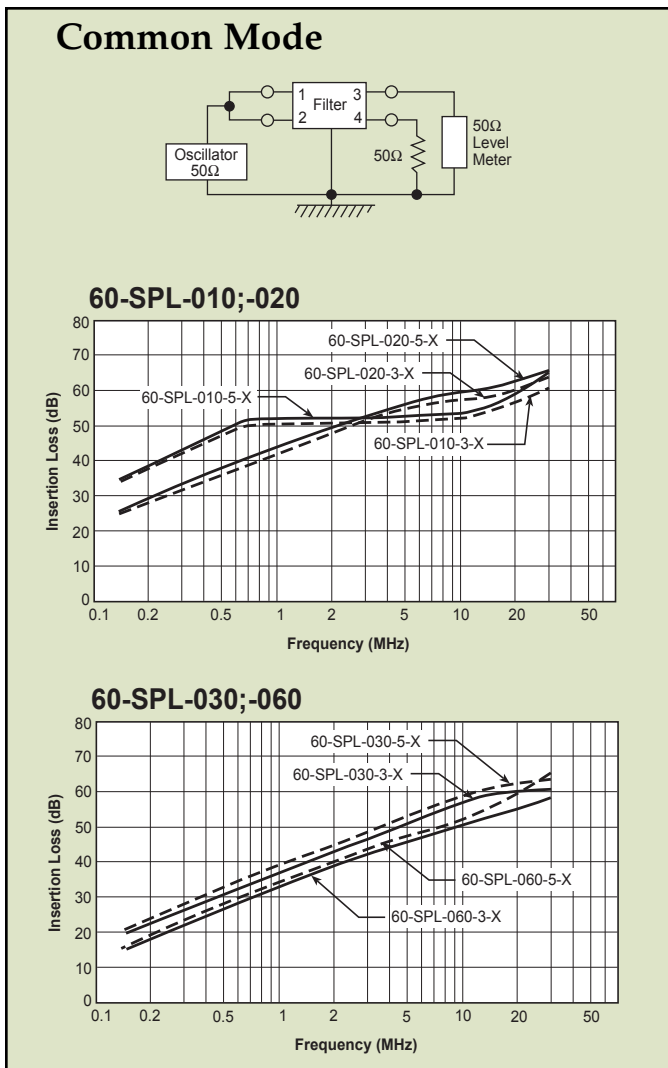
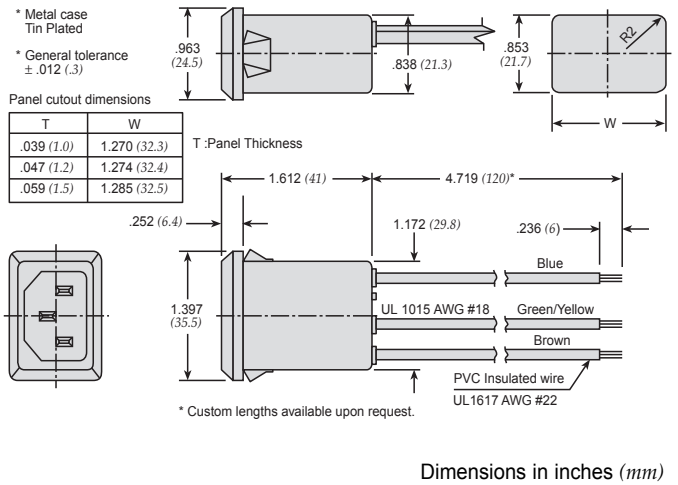
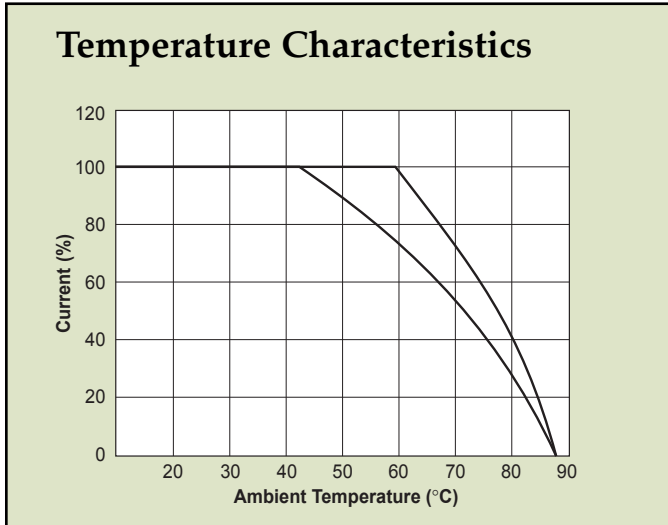

Power Entry Modules Bolt-in with Wire Leads



60-BPL Series

Features

- Ideally suited for products that must conform to FCC part 15 regulations
- Metal case filter offers high performance
- Meets over voltage of IEC 664 category II and complies with IEC 950
- Uses IEC connector that meets most safety standards
- Wire output for minimizing space use and economical installation
- Operating temperature: -25°C to +85°C (including temperature rise, see graph on page PF28)



Tested and found to be IAW VDE 0565 Part 3.

Applications

- Digital equipment
- Personal computers and peripherals
- Measuring instruments
- Monitor and display units

Circuit Diagram

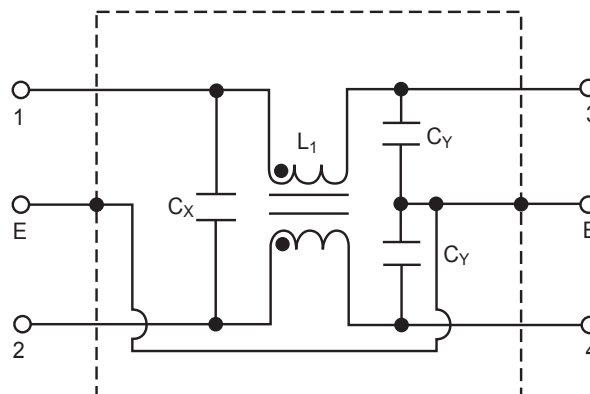

Specifications

| Model | Rated Voltage (@ 50/60Hz) | Rated Current | Leakage Current (Max.) | Capacitance | | Inductance (L ₁) | Temperature Rise (Max.) |
|----------------|---------------------------|---------------|------------------------|----------------|----------------|------------------------------|-------------------------|
| | | | | C _Y | C _X | | |
| 60-BPL-010-3-2 | 250VAC | 1A | 0.35mA | 2200pF ± 20% | 22nF ± 20% | 6.0mH | 30°C |
| 60-BPL-010-3-3 | | | | | 33nF ± 20% | | |
| 60-BPL-010-5-2 | | | 0.50mA | 3300pF ± 20% | 22nF ± 20% | | |
| 60-BPL-010-5-3 | | | | | 33nF ± 20% | | |
| 60-BPL-020-3-2 | 250VAC | 2A | 0.35mA | 2200pF ± 20% | 22nF ± 20% | 2.4mH | 30°C |
| 60-BPL-020-3-3 | | | | | 33nF ± 20% | | |
| 60-BPL-020-5-2 | | | 0.50mA | 3300pF ± 20% | 22nF ± 20% | | |
| 60-BPL-020-5-3 | | | | | 33nF ± 20% | | |
| 60-BPL-030-3-2 | 250VAC | 3A | 0.35mA | 2200pF ± 20% | .022uF ± 20% | 1.2mH | 30°C |
| 60-BPL-030-3-3 | | | | 3300pF ± 20% | | | |
| 60-BPL-030-5-2 | | | 0.50mA | 2200pF ± 20% | .033uF ± 20% | | |
| 60-BPL-030-5-3 | | | | | | | |
| 60-BPL-060-3-2 | 250VAC | 6A | 0.35mA | 2200pF ± 20% | 22nF ± 20% | 0.53mH | 45°C |
| 60-BPL-060-3-3 | | | | | 33nF ± 20% | | |
| 60-BPL-060-5-2 | | | 0.50mA | 3300pF ± 20% | 22nF ± 20% | | |
| 60-BPL-060-5-3 | | | | | 33nF ± 20% | | |

Note: Test voltage: 1500VAC one minute, line to ground
 Insulation resistance: 300 Mohm min. at 500VDC
 Voltage drop: 1V max. at rated current
 Weight: 50g
 Input: Compatible with IEC-320

Power Entry Modules Bolt-in with Wire Leads

60-BPL Series

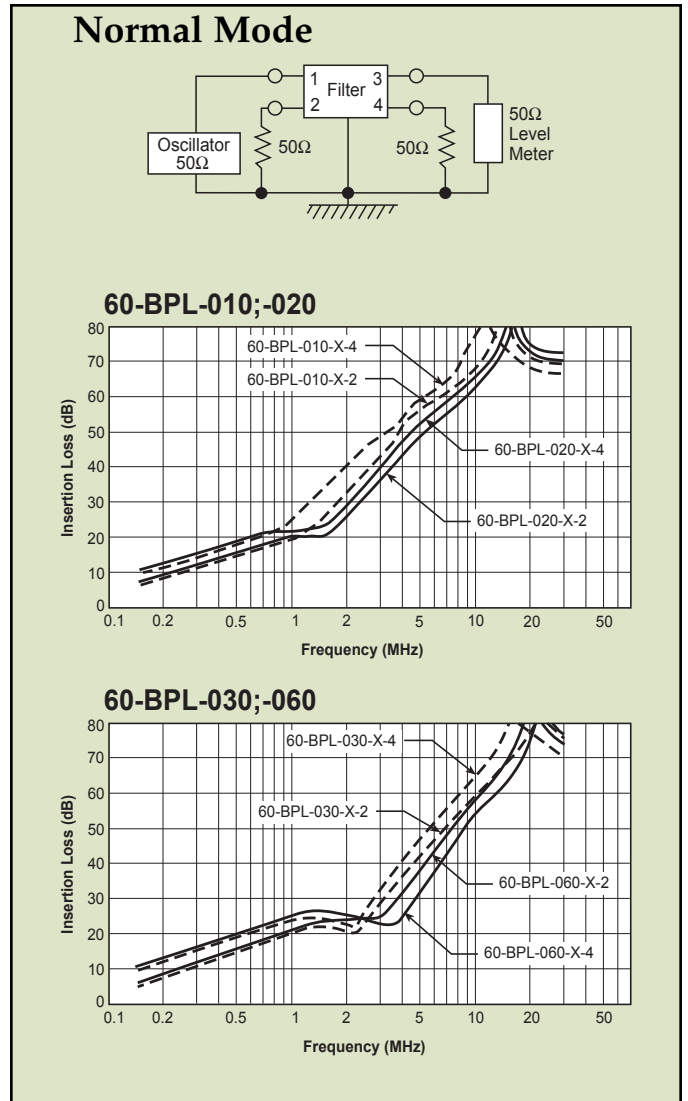
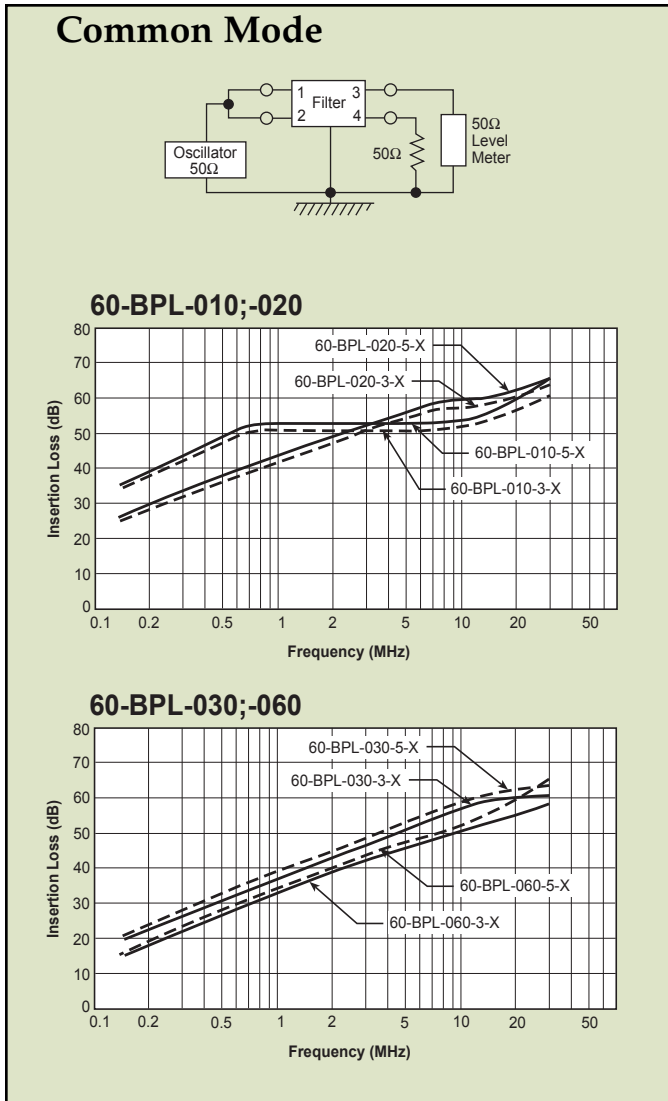
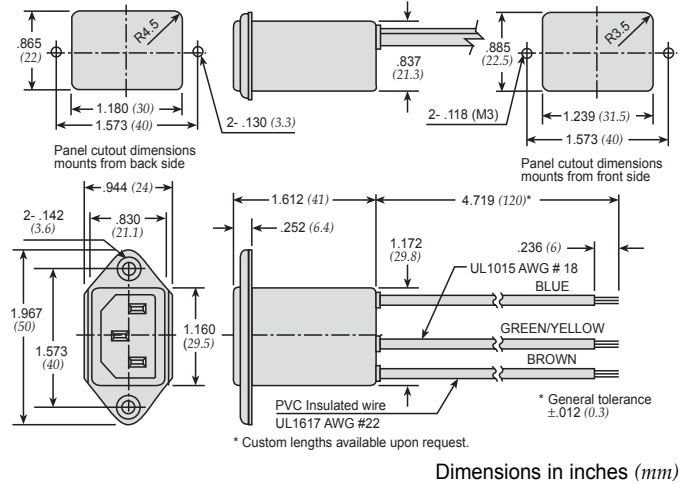
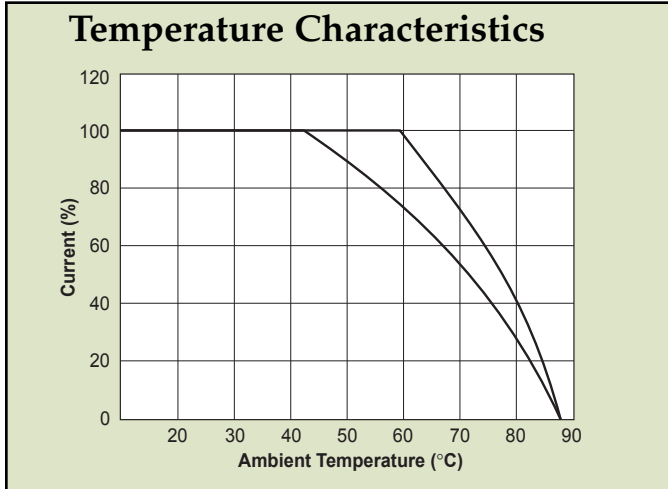

Power Entry Modules Bolt-in with Wire Leads



10-BPL Series



Features

- Ideally suited for products that must conform to FCC part 15 regulations
- Metal case filter offers high performance
- Meets over voltage of IEC 664 category II and complies with IEC 950
- Uses IEC connector that meets most safety standards
- Wire output for minimizing space use and economical installation
- Operating temperature: -25°C to +70°C
- Compact configuration

Applications

- Digital equipment
- Personal computers and peripherals
- Measuring instruments
- Monitor and display units

Circuit Diagram

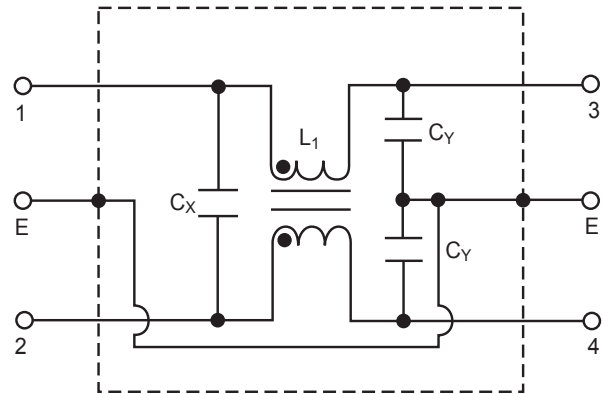

Specifications

| Model | Rated Voltage (@ 50/60Hz) | Rated Current | Leakage Current (Max.) | Capacitance | | Inductance (L ₁) | Circuit Diagram | Figure | Temperature Rise (Max.) |
|----------------|---------------------------|---------------|------------------------|----------------|----------------|------------------------------|-----------------|--------|-------------------------|
| | | | | C _Y | C _X | | | | |
| 10-BPL-001-5-B | 250VAC | 1A | 0.50mA | 3300pF | 0.01uF | 3.0mH | 1 | A | 30°C |
| 10-BPL-003-5-B | | 3A | | | | 1.5mH | | | |
| 10-BPL-006-5-B | | 6A | | | | 0.5mH | | | |

Note: Test voltage: 1500VAC one minute, line to ground
 Insulation resistance: 300 Mohm min. at 500VDC
 Voltage drop: 1V max. at rated current
 Weight: 50g
 Input: Compatible with IEC-320

Power Entry Modules Bolt-in with Wire Leads

10-BPL Series

Figure A

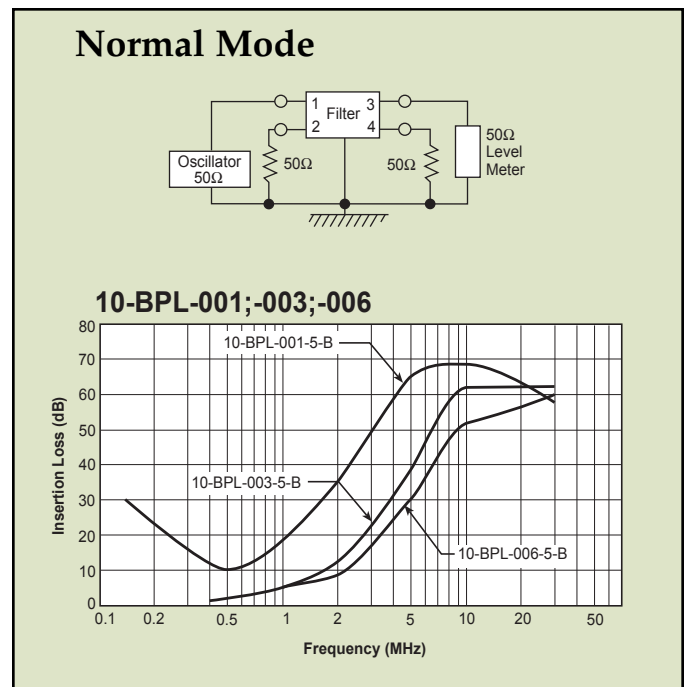
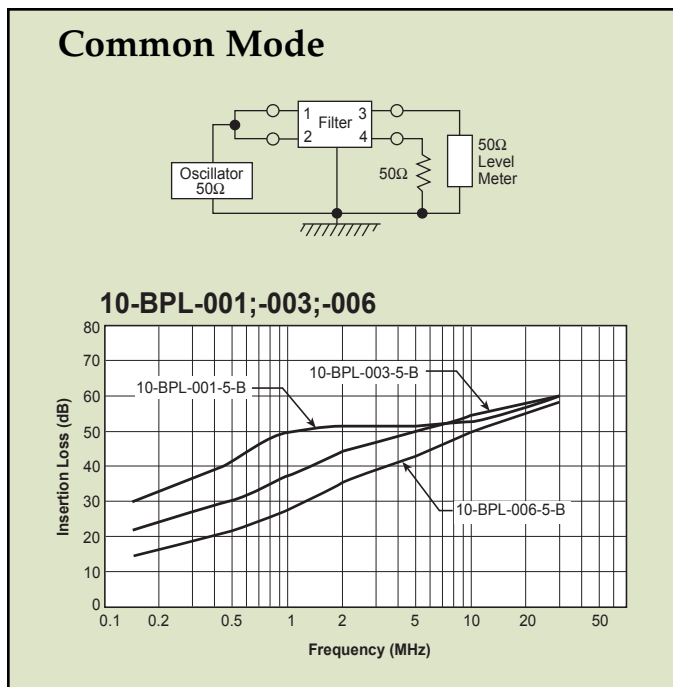
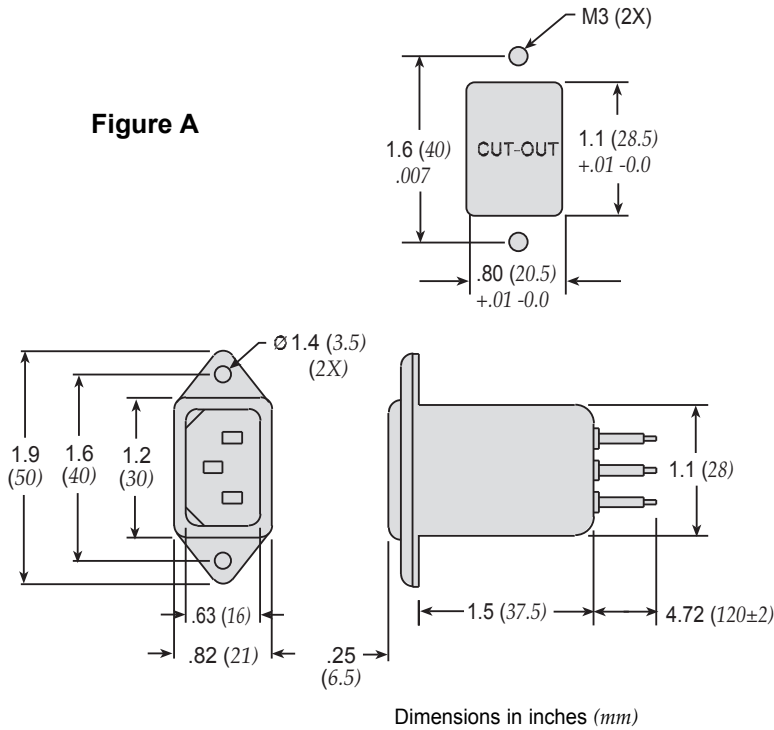

Power Entry Modules Snap-in Mount

60-SPR & SPS Series

Features

- Ideally suited for products that must conform to FCC part 15 regulations
- Metal cased miniature filter offers high performance
- Meets over voltage of IEC 664 category II and complies with IEC 950
- Uses IEC connector that meets most safety standards
- Snap-in style saves labor and hardware inventory
- Solder lug and fast-on tab terminations available
- Operating temperature: -25°C to +85°C (including temperature rise, see graph on page PF33)
- UL approved low leakage version also available

Applications

- Digital equipment
- Personal computers and peripherals
- Measuring instruments
- Monitor and display units



Tested and found to be IAW VDE 0565 Part 3.



Circuit Diagram

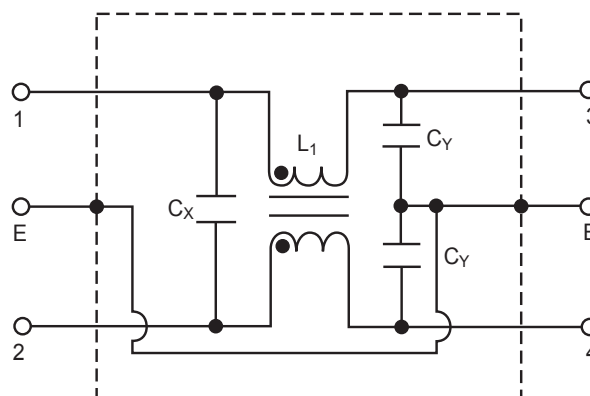

Specifications

| Model* | Rated Voltage (@ 50/60Hz) | Rated Current | Leakage Current (Max.) | Capacitance | | Inductance (L ₁) | Temperature Rise (Max.) |
|-----------------|---------------------------|---------------|------------------------|----------------|----------------|------------------------------|-------------------------|
| | | | | C _Y | C _X | | |
| 60-XXX-010-3-2 | 250VAC | 1A | 0.35mA | 2200pF ± 20% | .022uF ± 20% | 6.0mH | 30°C |
| 60-XXX-010-3-4 | | | | | .047uF ± 20% | | |
| 60-XXX-010-5-2 | | | 0.50mA | 3300pF ± 20% | .022uF ± 20% | | |
| 60-XXX-010-5-4 | | | | .047uF ± 20% | | | |
| 60-XXX-020-3-2 | 250VAC | 2A | 0.35mA | 2200pF ± 20% | .022uF ± 20% | 2.4mH | 30°C |
| 60-XXX-020-3-4 | | | | | .047uF ± 20% | | |
| 60-XXX-020-5-2 | | | 0.50mA | 3300pF ± 20% | .022uF ± 20% | | |
| 60-XXX-020-5-4 | | | | .047uF ± 20% | | | |
| 60-XXX-030-3-2 | 250VAC | 3A | 0.35mA | 2200pF ± 20% | .022uF ± 20% | 1.2mH | 30°C |
| 60-XXX-030-3-4 | | | | | .047uF ± 20% | | |
| 60-XXX-030-5-2 | | | 0.50mA | 3300pF ± 20% | .022uF ± 20% | | |
| 60-XXX-030-5-4 | | | | .047uF ± 20% | | | |
| 60-XXX-060-3-2 | 250VAC | 6A | 0.35mA | 2200pF ± 20% | .022uF ± 20% | 0.53mH | 45°C |
| 60-XXX-060-3-4 | | | | | .047uF ± 20% | | |
| 60-XXX-060-5-2 | | | 0.50mA | 3300pF ± 20% | .022uF ± 20% | | |
| 60-XXX-060-5-4 | | | | .047uF ± 20% | | | |
| 60-XXX-100-3-2 | 250VAC | 10A | 0.35mA | 2200pF ± 20% | .022uF ± 20% | 0.26mH | 45°C |
| 60-XXX-100-5-2 | | | 0.50mA | 3300pF ± 20% | | | |
| 60-SPR-150-3-11 | 250VAC | 15A | 0.35mA | 2200pF ± 20% | .1uF ± 20% | 0.15mH | 45°C |

Note: Test voltage: 1500VAC one minute, line to ground
 Insulation resistance: 300 Mohm min. at 500VDC
 Voltage drop: 1V max. at rated current
 Weight: 45g
 Input: Compatible with IEC-320

* Substitute SPR or SPS for XXX
 60-SPR - Fast-on terminals
 60-SPS - Solder lug terminals

Power Entry Modules Snap-in Mount

60-SPR & SPS Series

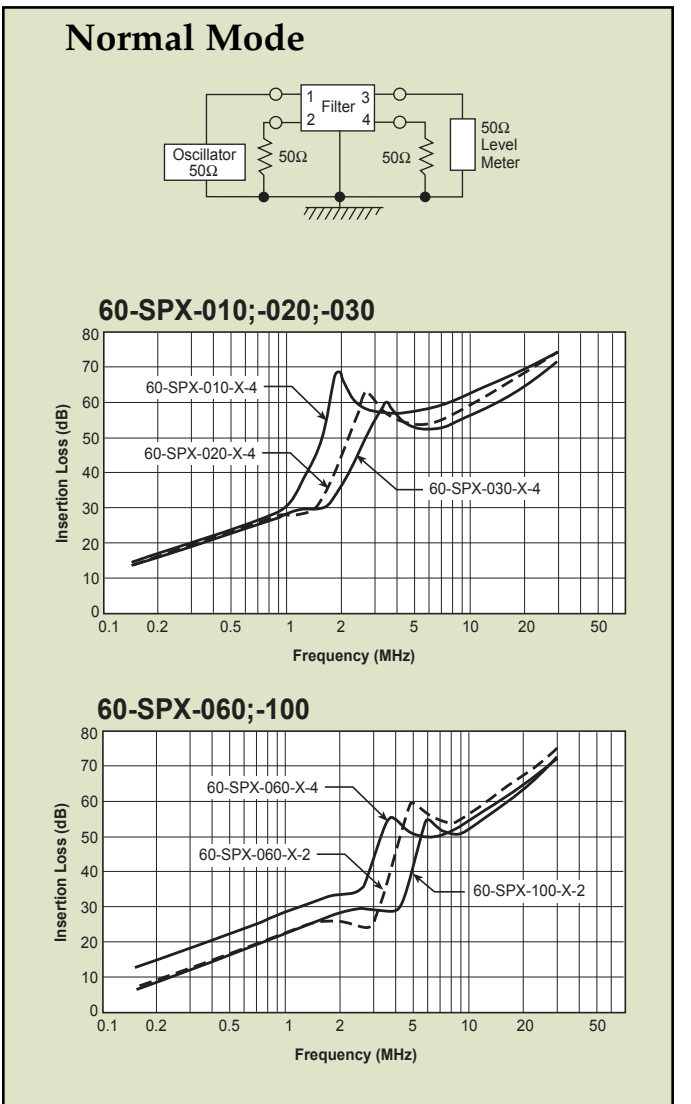
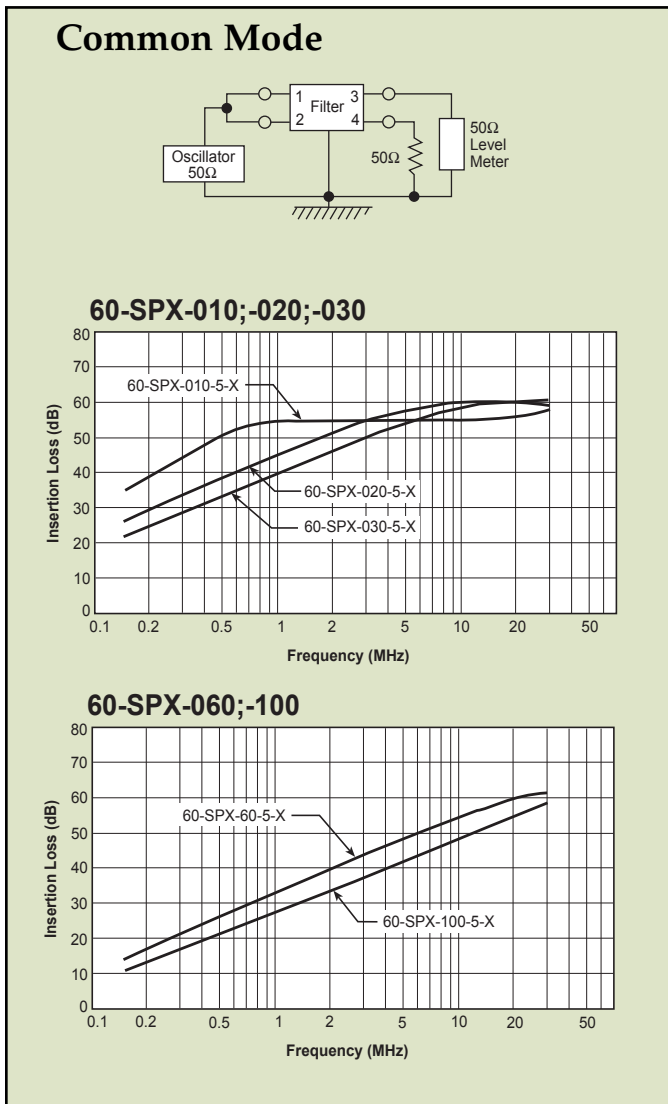
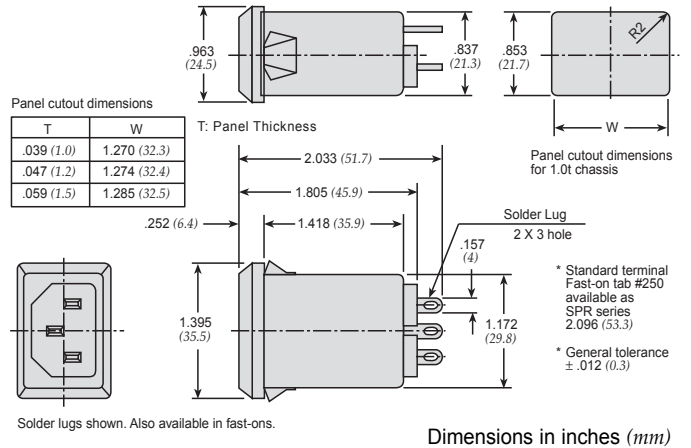
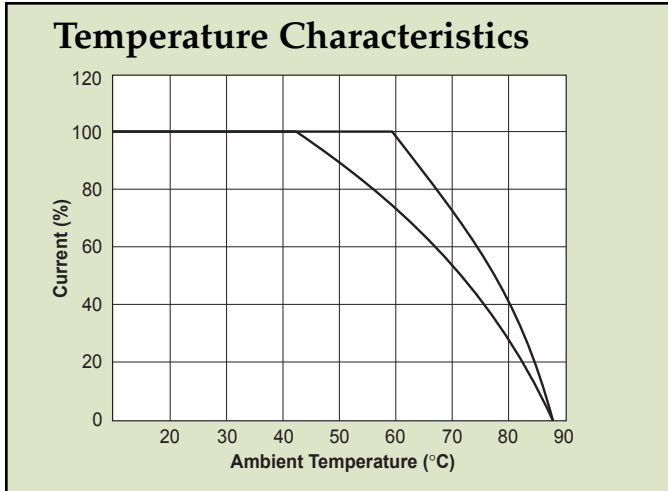

Fused Filtered Power Entry Modules

For General Purpose Applications



64-65-BFF/64-65-BFS Series



Tested and found to be IAW VDE 0565 Part 3.

Features

- North American and Metric fuse holders available
- Fuse holder provides effective EMI suppression of common and differential mode
- Suitable for products that must conform to FCC and FTZ requirements
- Meets over voltage category II of IEC 664 and complies with IEC 950
- Fast-on terminals or solder lug terminals
- Metal case provides effective EMI shielding
- Operating temperature: -25°C to +85°C (including temperature rise, see graph on page PF35)

Applications

- Computers and peripheral equipment
- Electronic equipment
- Digital equipment
- Measuring and testing instruments
- Telecommunications equipment

Circuit Diagram

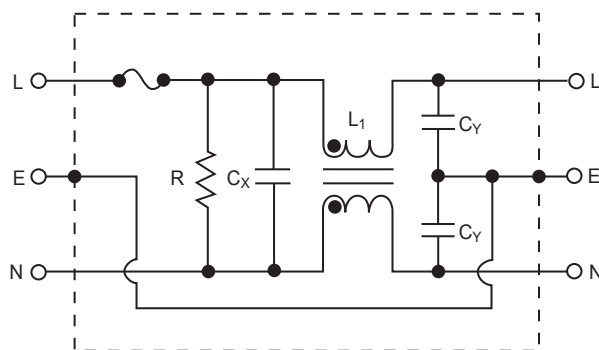

Specifications

| Model* | Rated Voltage (@ 50/60Hz) | Rated Current | Leakage Current (Max.) | Capacitance | | Inductance (L ₁) | Temperature Rise (Max.) |
|-----------------|---------------------------|---------------|------------------------|----------------|----------------|------------------------------|-------------------------|
| | | | | C _Y | C _X | | |
| 64-XXX-020-3-11 | 250VAC | 2A | 0.35mA | 2200pF ± 20% | 0.1uF | 6.5mH | 40°C |
| 64-XXX-020-5-11 | | | 0.50mA | 3300pF ± 20% | | | |
| 64-XXX-020-3-12 | | | 0.35mA | 2200pF ± 20% | 0.22uF | | |
| 64-XXX-020-5-12 | | | 0.50mA | 3300pF ± 20% | | | |
| 64-XXX-040-3-11 | 250VAC | 4A | 0.35mA | 2200pF ± 20% | 0.1uF | 4.2mH | 45°C |
| 64-XXX-040-5-11 | | | 0.50mA | 3300pF ± 20% | | | |
| 64-XXX-040-3-12 | | | 0.35mA | 2200pF ± 20% | 0.22uF | | |
| 64-XXX-040-5-12 | | | 0.50mA | 3300pF ± 20% | | | |
| 64-XXX-060-3-11 | 250VAC | 6A | 0.35mA | 2200pF ± 20% | 0.1uF | 1.6mH | 45°C |
| 64-XXX-060-5-11 | | | 0.50mA | 3300pF ± 20% | | | |
| 64-XXX-060-3-12 | | | 0.35mA | 2200pF ± 20% | 0.22uF | | |
| 64-XXX-060-5-12 | | | 0.50mA | 3300pF ± 20% | | | |
| 65-XXX-020-3-11 | 125VAC | 2A | 0.20mA | 2200pF ± 20% | 0.1uF | 6.5mH | 40°C |
| 65-XXX-020-5-11 | | | 0.25mA | 3300pF ± 20% | | | |
| 65-XXX-020-3-12 | | | 0.20mA | 2200pF ± 20% | 0.22uF | | |
| 65-XXX-020-5-12 | | | 0.25mA | 3300pF ± 20% | | | |
| 65-XXX-040-3-11 | 125VAC | 4A | 0.20mA | 2200pF ± 20% | 0.1uF | 4.2mH | 45°C |
| 65-XXX-040-5-11 | | | 0.25mA | 3300pF ± 20% | | | |
| 65-XXX-040-3-12 | | | 0.20mA | 2200pF ± 20% | 0.22uF | | |
| 65-XXX-040-5-12 | | | 0.25mA | 3300pF ± 20% | | | |
| 65-XXX-060-3-11 | 125VAC | 6A | 0.20mA | 2200pF ± 20% | 0.1uF | 1.6mH | 45°C |
| 65-XXX-060-5-11 | | | 0.25mA | 3300pF ± 20% | | | |
| 65-XXX-060-3-12 | | | 0.20mA | 2200pF ± 20% | 0.22uF | | |
| 65-XXX-060-5-12 | | | 0.25mA | 3300pF ± 20% | | | |

Note: Test Voltage 1500VAC one minute, line to ground
Insulation Resistance: 300 MΩ min. at 500VDC
F(S) = Fast-on or (Solder lug terminals)

Voltage Drop: 1V max. at rated current
Weight: 78g
Inlet: Compatible with IEC-320

* Substitute BFF or BFS for XXX
BFF - Fast-on terminals
BFS - Solder lug terminals

Fused Filtered Power Entry Modules

For General Purpose Applications

64-65-BFF/64-65-BFS Series

Temperature Characteristics

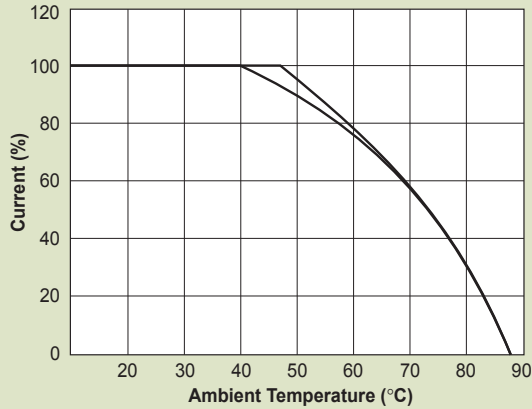

Dimensions 64/65-BFF Series

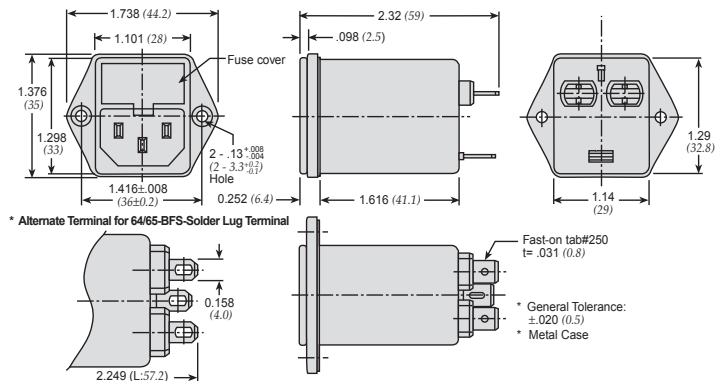

Dimensions in inches (mm)

Common Mode

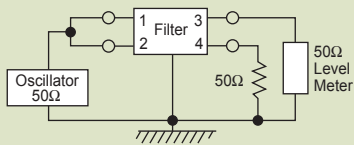

0.50 mA Leakage Versions

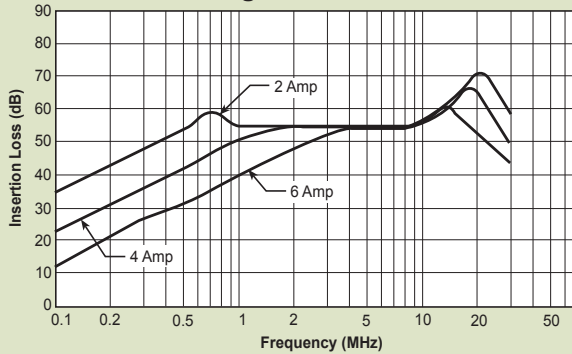

0.35 mA Leakage Versions

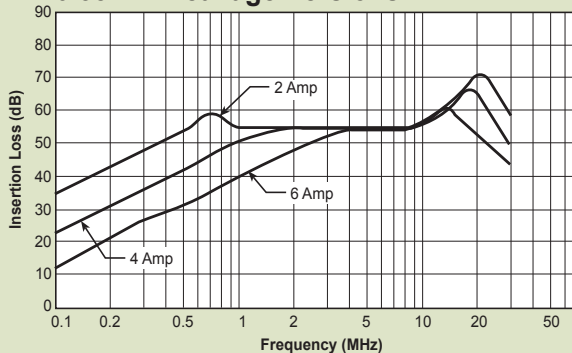

Normal Mode

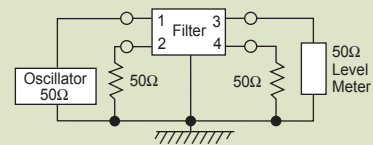

0.50 mA Leakage Versions

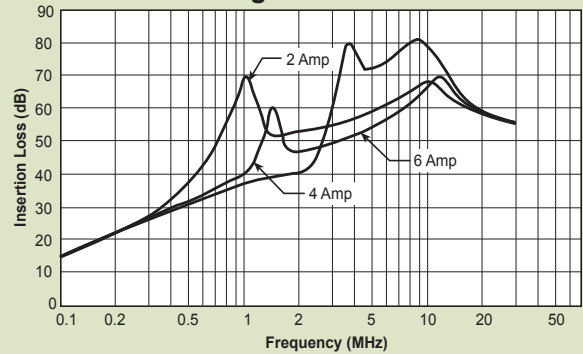

0.35 mA Leakage Versions

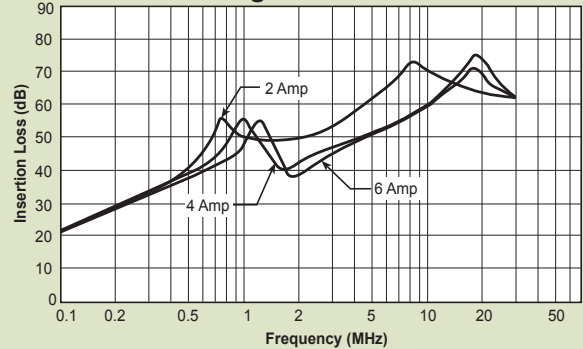

Fused Filtered Power Entry Modules

For Medical or General Purpose Applications

66-67-BFF/66-67-BFS Series



Tested and found to be IAW VDE 0565 Part 3.

Features

- Metric and North American fuse holders available
- Fuse holder provides effective EMI suppression of common and differential mode
- Suitable for products that must conform to FCC and FTZ requirements
- Meets over voltage category II of IEC 664 and complies with IEC 950
- Fast-on terminations or solder lug terminations
- Metal case provides effective EMI shielding
- Provides susceptibility protection without the leakage current associated with line-to-ground capacitance
- Reduces the line to ground capacitance in order to meet patient care requirements
- Operating temperature: -25°C to +85°C (including temperature rise, see graph on page PF37)



Applications

- Medical equipment
- Electronic equipment
- Digital equipment
- Industrial equipment
- Telecommunications equipment
- Measuring and testing instruments
- Personal computers and peripherals

Circuit Diagrams

66/67-BFF(S)-XXX-1-X Filter

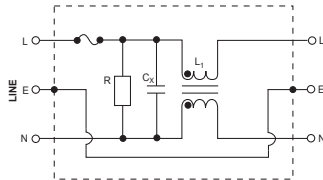

66/67-BFF(S)-XXX-0-X and 66/67-BFF(S)-XXX-4-X Filters

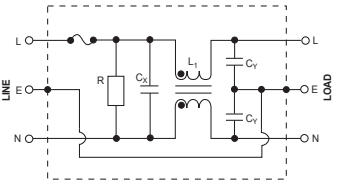

Specifications

| Model* | Rated Voltage (@ 50/60Hz) | Rated Current | Leakage Current (Max.) | Capacitance | | Inductance (L ₁) | Temperature Rise (Max.) | | |
|-----------------|---------------------------|---------------|------------------------|----------------|----------------|------------------------------|-------------------------|-------------|--------|
| | | | | C _Y | C _X | | | | |
| 66-XXX-020-1-11 | 250VAC | 2A | 0.01mA | none | 0.1uF | 6.5mH | 40°C | | |
| 66-XXX-020-1-12 | | | | | 0.22uF | | | | |
| 66-XXX-020-0-11 | | | | | 0.075mA | | | 330pF ± 20% | 0.1uF |
| 66-XXX-020-4-11 | | | | | 0.1mA | | | 470pF ± 20% | |
| 66-XXX-020-0-12 | | | | | 0.075mA | | | 330pF ± 20% | 0.22uF |
| 66-XXX-020-4-12 | | | | | 0.1mA | | | 470pF ± 20% | |
| 66-XXX-040-1-11 | 250VAC | 4A | 0.01mA | none | 0.1uF | 2.4mH | 45°C | | |
| 66-XXX-040-1-12 | | | | | 0.22uF | | | | |
| 66-XXX-040-0-11 | | | | | 0.075mA | | | 330pF ± 20% | 0.1uF |
| 66-XXX-040-4-11 | | | | | 0.1mA | | | 470pF ± 20% | |
| 66-XXX-040-0-12 | | | | | 0.075mA | | | 330pF ± 20% | 0.22uF |
| 66-XXX-040-4-12 | | | | | 0.1mA | | | 470pF ± 20% | |
| 66-XXX-060-1-11 | 250VAC | 6A | 0.01mA | none | 0.1uF | 1.6mH | 45°C | | |
| 66-XXX-060-1-12 | | | | | 0.22uF | | | | |
| 66-XXX-060-0-11 | | | | | 0.075mA | | | 330pF ± 20% | 0.1uF |
| 66-XXX-060-4-11 | | | | | 0.1mA | | | 470pF ± 20% | |
| 66-XXX-060-0-12 | | | | | 0.075mA | | | 330pF ± 20% | 0.22uF |
| 66-XXX-060-4-12 | | | | | 0.1mA | | | 470pF ± 20% | |
| 67-XXX-020-1-11 | 125VAC | 2A | 0.005mA | none | 0.1uF | 6.5mH | 40°C | | |
| 67-XXX-020-1-12 | | | | | 0.22uF | | | | |
| 67-XXX-020-0-11 | | | | | 0.035mA | | | 330pF ± 20% | 0.1uF |
| 67-XXX-020-4-11 | | | | | 0.05mA | | | 470pF ± 20% | |
| 67-XXX-020-0-12 | | | | | 0.035mA | | | 330pF ± 20% | 0.22uF |
| 67-XXX-020-4-12 | | | | | 0.05mA | | | 470pF ± 20% | |
| 67-XXX-040-1-11 | 125VAC | 4A | 0.005mA | none | 0.1uF | 2.4mH | 45°C | | |
| 67-XXX-040-1-12 | | | | | 0.22uF | | | | |
| 67-XXX-040-0-11 | | | | | 0.035mA | | | 330pF ± 20% | 0.1uF |
| 67-XXX-040-4-11 | | | | | 0.05mA | | | 470pF ± 20% | |
| 67-XXX-040-0-12 | | | | | 0.035mA | | | 330pF ± 20% | 0.22uF |
| 67-XXX-040-4-12 | | | | | 0.05mA | | | 470pF ± 20% | |
| 67-XXX-060-1-11 | 125VAC | 6A | 0.005mA | none | 0.1uF | 1.6mH | 45°C | | |
| 67-XXX-060-1-12 | | | | | 0.22uF | | | | |
| 67-XXX-060-0-11 | | | | | 0.035mA | | | 330pF ± 20% | 0.1uF |
| 67-XXX-060-4-11 | | | | | 0.05mA | | | 470pF ± 20% | |
| 67-XXX-060-0-12 | | | | | 0.035mA | | | 330pF ± 20% | 0.22uF |
| 67-XXX-060-4-12 | | | | | 0.05mA | | | 470pF ± 20% | |

Note: Test Voltage 1500VAC one minute, line to ground
Insulation Resistance: 300 MΩ min. at 500VDC
F(S) = Fast-on or (Solder lug terminals)

Voltage Drop: 1V max. at rated current
Weight: 78g
Inlet: Compatible with IEC-320

* Substitute BFF or BFS for XXX
BFF - Fast-on terminals
BFS - Solder lug terminals

Fused Filtered Power Entry Modules

For Medical or General Purpose Applications

66-67-BFF/66-67-BFS Series

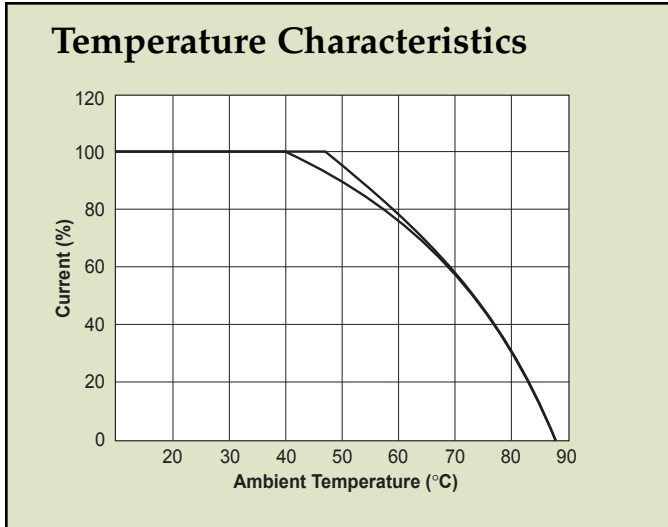

Dimensions

66-67-BFF/66-67-BFS Series

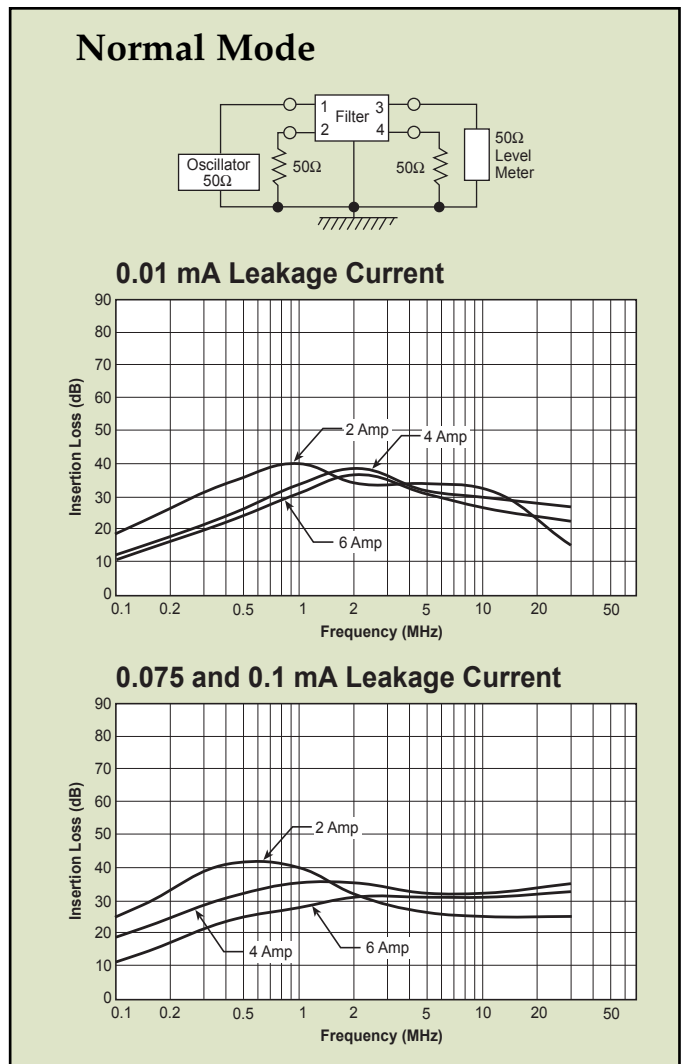
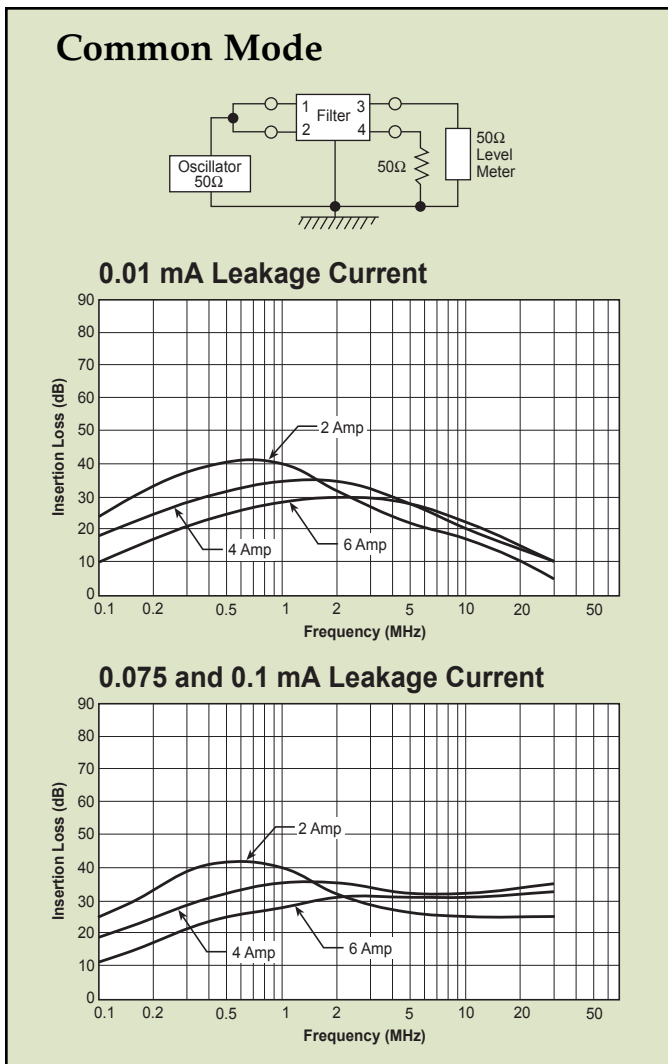
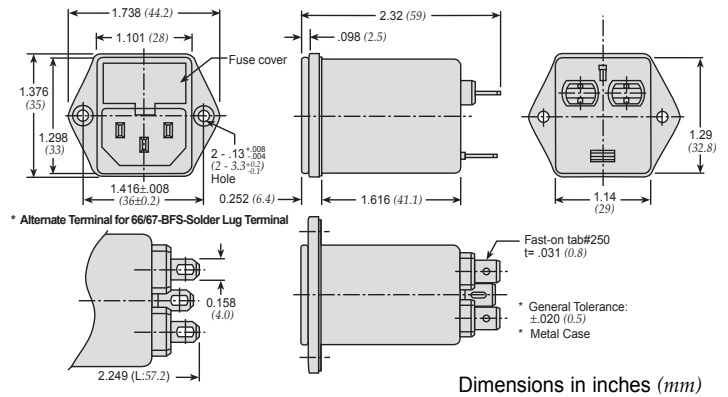

Switched and Fused Filtered Power Entry Modules

For General Purpose Applications



64-65-BSF/64-65-SSF Series



Tested and found to be IAW VDE 0565 Part 3.

Features

- North American and Metric fuse holders available
- Fuse holder and double pole power ON/OFF switch provided in a convenient/compact package
- Suitable for products that must conform to FCC and FTZ requirements
- Meets over voltage category II of IEC 664 and complies with IEC 950
- Metal case provides effective EMI shielding
- Easy access fuse drawer with space for spare fuse
- Flange-mounted or snap-in styles available for quick mounting
- Operating temperature: -25°C to +85°C (including temperature rise, see graph on page PF39)

Applications

- Computers and peripheral equipment
- Digital equipment
- Electronic equipment
- Measuring and testing instruments
- Telecommunications equipment

Circuit Diagram

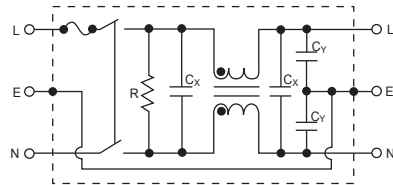

Specifications

| Model* | Rated Voltage (@ 50/60Hz) | Rated Current | Leakage Current (Max.) | Capacitance | | | Inductance (L ₁) | Temperature Rise (Max.) |
|-----------------|---------------------------|---------------|------------------------|----------------|-----------------|-----------------|------------------------------|-------------------------|
| | | | | C _Y | C _{X1} | C _{X2} | | |
| 64-XXX-020-3-12 | 250VAC | 2A | 0.35mA | 2200pF | 0.22uF | NONE | 10.5mH | 45°C |
| 64-XXX-020-3-04 | | | | | | 0.22uF | | |
| 64-XXX-020-3-14 | | | | | | NONE | | |
| 64-XXX-020-3-06 | | | 0.22uF | | | | | |
| 64-XXX-020-5-12 | | | 0.50mA | 3300pF | 0.22uF | NONE | | |
| 64-XXX-020-5-04 | | | | | | 0.22uF | | |
| 64-XXX-020-5-14 | NONE | | | | | | | |
| 64-XXX-020-5-06 | 250VAC | 4A | 0.35mA | 2200pF | 0.22uF | NONE | 4.2mH | 45°C |
| 64-XXX-040-3-12 | | | | | | 0.22uF | | |
| 64-XXX-040-3-04 | | | | | | NONE | | |
| 64-XXX-040-3-14 | | | 0.22uF | | | | | |
| 64-XXX-040-3-06 | | | 0.50mA | 3300pF | 0.22uF | NONE | | |
| 64-XXX-040-5-12 | | | | | | 0.22uF | | |
| 64-XXX-040-5-04 | NONE | | | | | | | |
| 64-XXX-040-5-14 | 250VAC | 6A | 0.35mA | 2200pF | 0.22uF | NONE | 1.6mH | 45°C |
| 64-XXX-060-3-12 | | | | | | 0.22uF | | |
| 64-XXX-060-3-04 | | | | | | NONE | | |
| 64-XXX-060-3-14 | | | 0.22uF | | | | | |
| 64-XXX-060-3-06 | | | 0.50mA | 3300pF | 0.22uF | NONE | | |
| 64-XXX-060-5-12 | | | | | | 0.22uF | | |
| 64-XXX-060-5-04 | NONE | | | | | | | |
| 64-XXX-060-5-14 | 125VAC | 2A | 0.20mA | 2200pF | 0.22uF | NONE | 10.5mH | 45°C |
| 65-XXX-020-3-12 | | | | | | 0.22uF | | |
| 65-XXX-020-3-04 | | | | | | NONE | | |
| 65-XXX-020-3-14 | | | 0.22uF | | | | | |
| 65-XXX-020-3-06 | | | 0.25mA | 3300pF | 0.22uF | NONE | | |
| 65-XXX-020-5-12 | | | | | | 0.22uF | | |
| 65-XXX-020-5-04 | NONE | | | | | | | |
| 65-XXX-020-5-14 | 125VAC | 4A | 0.20mA | 2200pF | 0.22uF | NONE | 4.2mH | 45°C |
| 65-XXX-040-3-12 | | | | | | 0.22uF | | |
| 65-XXX-040-3-04 | | | | | | NONE | | |
| 65-XXX-040-3-14 | | | 0.22uF | | | | | |
| 65-XXX-040-3-06 | | | 0.25mA | 3300pF | 0.22uF | NONE | | |
| 65-XXX-040-5-12 | | | | | | 0.22uF | | |
| 65-XXX-040-5-04 | NONE | | | | | | | |
| 65-XXX-040-5-14 | 125VAC | 6A | 0.20mA | 2200pF | 0.22uF | NONE | 1.6mH | 45°C |
| 65-XXX-060-3-12 | | | | | | 0.22uF | | |
| 65-XXX-060-3-04 | | | | | | NONE | | |
| 65-XXX-060-3-14 | | | 0.22uF | | | | | |
| 65-XXX-060-3-06 | | | 0.25mA | 3300pF | 0.22uF | NONE | | |
| 65-XXX-060-5-12 | | | | | | 0.22uF | | |
| 65-XXX-060-5-04 | NONE | | | | | | | |
| 65-XXX-060-5-14 | 125VAC | 2A | 0.20mA | 2200pF | 0.22uF | NONE | 10.5mH | 45°C |
| 65-XXX-060-5-06 | | | | | | 0.22uF | | |
| 65-XXX-060-5-04 | | | | | | NONE | | |
| 65-XXX-060-5-12 | | | 0.22uF | | | | | |
| 65-XXX-060-5-04 | | | 0.25mA | 3300pF | 0.22uF | NONE | | |
| 65-XXX-060-5-14 | | | | | | 0.22uF | | |
| 65-XXX-060-5-06 | NONE | | | | | | | |

Note: Test Voltage 1500VAC one minute, line to ground
Insulation Resistance: 300 MΩ min. at 500VDC
B(S) = Bolt-in terminals or (Snap-in terminals)

Voltage Drop: 1V max. at rated current
Weight: 130g
Inlet: Compatible with IEC-320

* Substitute BSF or SSF for XXX
BSF - Bolt-in switched and fused
SSF - Snap-in switched and fused

Switched and Fused Filtered Power Entry Modules

For General Purpose Applications

Temperature Characteristics

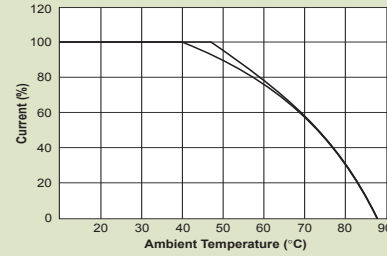

Dimensions

64/65-BSF Series

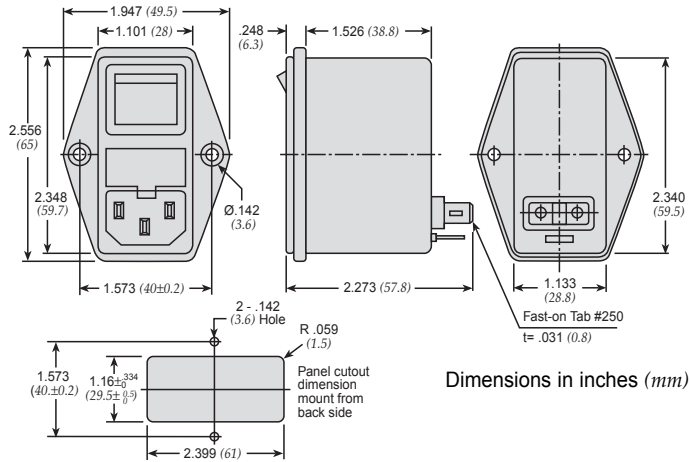

64/65-SSF Series

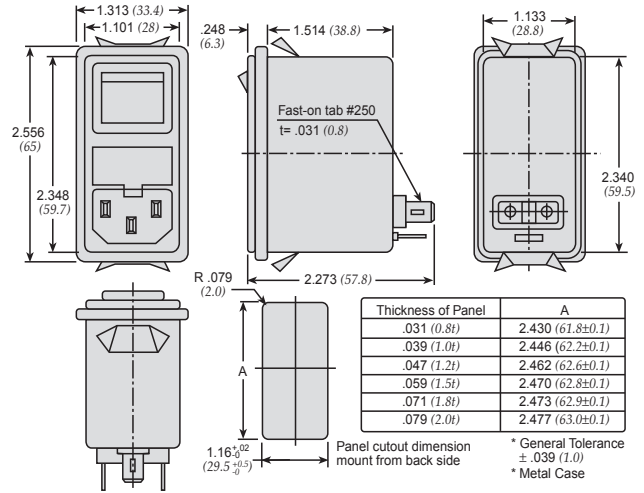

Common Mode

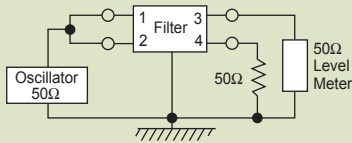

0.35 mA Leakage Versions

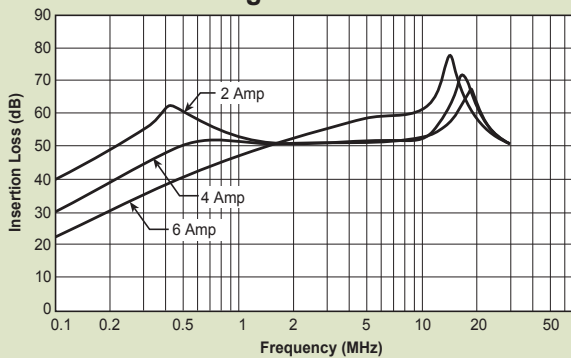

0.50 mA Leakage Versions

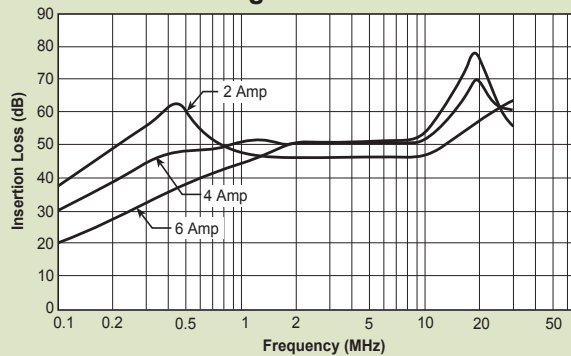

Normal Mode

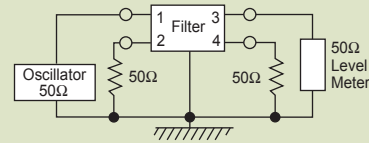

64/65-B(S)SF-*. *-02(04,06)

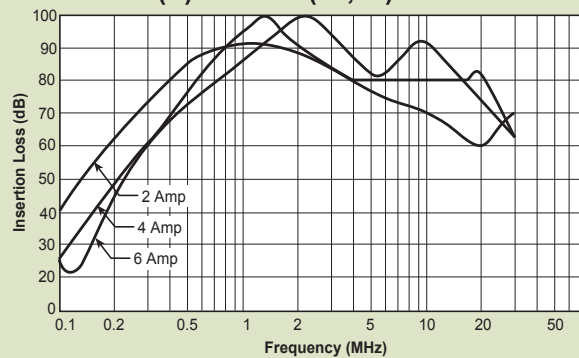

64/65-B(S)SF-*. *-11(12,14)

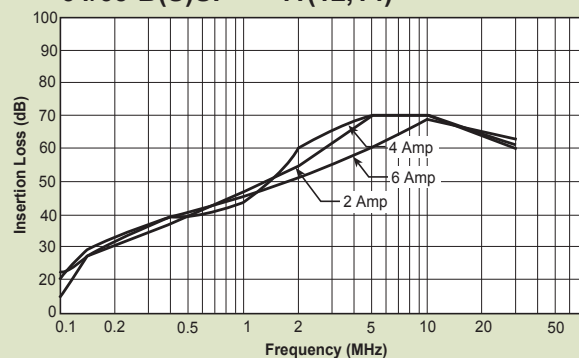

Switched and Fused Filtered Power Entry Modules

For Medical or General Purpose Applications

66-67-BSF/66-67-SSF Series



Tested and found to be IAW VDE 0565 Part 3

Features

- Metric and North American fuse holders available
- Fuse holder and a double pole power ON/OFF switch provides a convenient/compact package
- Suitable for products that must conform to FCC and FTZ requirements
- Meets over voltage category II of IEC 664 and complies with IEC 950
- Provides susceptibility protection without the leakage current associated with line-to-ground capacitors
- Designed to meet requirements for non-patient and patient care equipment
- Metal case provides effective EMI shielding
- Easy access fuse drawer - space for spare fuse
- Flange-mounted or snap-in styles available for quick mounting
- Operating temperature: -25°C to +85°C (including temperature rise, see graph on page PF41)

Specifications

| Model* | Rated Voltage 50/60Hz | Rated Current | Leakage Current (Max.) | Capacitance | | | Temp. Induct. (L ₁) | Rise (Max.) | | |
|-----------------|--------------------------|---------------|---------------------------|----------------|-----------------|-----------------|------------------------------------|----------------|-------|------|
| | | | | C _Y | C _{X1} | C _{X2} | | | | |
| 66-XXX-020-0-12 | 250 VAC | 2A | .075mA | 330pF | 0.22uF | NONE | 10.5mH | 40°C | | |
| 66-XXX-020-0-04 | | | | | 0.22uF | NONE | | | | |
| 66-XXX-020-0-14 | | | | | 0.47uF | NONE | | | | |
| 66-XXX-020-0-06 | | | | | 0.22uF | NONE | | | | |
| 66-XXX-020-1-12 | | | | | 0.22uF | NONE | | | | |
| 66-XXX-020-1-04 | | | | | 0.22uF | NONE | | | | |
| 66-XXX-020-1-14 | | | .01mA | NONE | 0.22uF | NONE | | | | |
| 66-XXX-020-1-04 | | | | | 0.22uF | NONE | | | | |
| 66-XXX-020-1-14 | | | | | 0.47uF | NONE | | | | |
| 66-XXX-020-1-06 | | | | | 0.22uF | NONE | | | | |
| 66-XXX-020-4-12 | | | | | 0.22uF | NONE | | | | |
| 66-XXX-020-4-04 | | | | | 0.22uF | NONE | | | | |
| 66-XXX-020-4-14 | | 0.1mA | 470pF | 0.47uF | NONE | | | | | |
| 66-XXX-020-4-06 | | | | 0.22uF | NONE | | | | | |
| 66-XXX-040-0-12 | | | | 4A | .075mA | 330pF | 0.22uF | NONE | 4.2mH | 45°C |
| 66-XXX-040-0-04 | | | | | | | 0.22uF | NONE | | |
| 66-XXX-040-0-14 | | | | | | | 0.47uF | NONE | | |
| 66-XXX-040-0-06 | | | | | | | 0.22uF | NONE | | |
| 66-XXX-040-1-12 | | 0.22uF | NONE | | | | | | | |
| 66-XXX-040-1-04 | | 0.22uF | NONE | | | | | | | |
| 66-XXX-040-1-14 | | .01mA | NONE | | | 0.47uF | NONE | | | |
| 66-XXX-040-1-06 | | | | | | 0.22uF | NONE | | | |
| 66-XXX-040-4-12 | | | | | | 0.22uF | NONE | | | |
| 66-XXX-040-4-04 | | | | | | 0.22uF | NONE | | | |
| 66-XXX-040-4-14 | 0.47uF | | | | | NONE | | | | |
| 66-XXX-040-4-06 | 0.22uF | | | | | NONE | | | | |
| 66-XXX-060-0-12 | 6A | .075mA | 330pF | | 0.22uF | NONE | 1.6mH | 45°C | | |
| 66-XXX-060-0-04 | | | | | 0.22uF | NONE | | | | |
| 66-XXX-060-0-14 | | | | | 0.47uF | NONE | | | | |
| 66-XXX-060-0-06 | | | | | 0.22uF | NONE | | | | |
| 66-XXX-060-1-12 | | | | | 0.22uF | NONE | | | | |
| 66-XXX-060-1-04 | | | | | 0.22uF | NONE | | | | |
| 66-XXX-060-1-14 | | .01mA | NONE | | 0.47uF | NONE | | | | |
| 66-XXX-060-1-06 | | | | | 0.22uF | NONE | | | | |
| 66-XXX-060-4-12 | | | | | 0.22uF | NONE | | | | |
| 66-XXX-060-4-04 | | | | | 0.22uF | NONE | | | | |
| 66-XXX-060-4-14 | | | | | 0.47uF | NONE | | | | |
| 66-XXX-060-4-06 | | | | | 0.22uF | NONE | | | | |



Applications

- Medical equipment
- Industrial equipment
- Telecommunications equipment
- Measuring and testing instruments
- Digital equipment (including switching power supplies)
- General purpose filter for susceptibility or high frequency "clean up" applications

Circuit Diagram

Note: C_{Y1} and C_{Y2} capacitors omitted on 66/67 B(S)F-XXX-1-X Filters

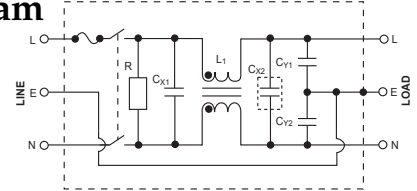

| Model* | Rated Voltage 50/60Hz | Rated Current | Leakage Current (Max.) | Capacitance | | | Temp. Induct. (L ₁) | Rise (Max.) | |
|-----------------|--------------------------|---------------|---------------------------|----------------|-----------------|-----------------|------------------------------------|----------------|------|
| | | | | C _Y | C _{X1} | C _{X2} | | | |
| 67-XXX-020-0-12 | 250 VAC | 2A | 0.04mA | 330pF | 0.22uF | NONE | 10.5mH | 40°C | |
| 67-XXX-020-0-04 | | | | | 0.22uF | NONE | | | |
| 67-XXX-020-0-14 | | | | | 0.47uF | NONE | | | |
| 67-XXX-020-0-06 | | | | | 0.22uF | NONE | | | |
| 67-XXX-020-1-12 | | | | | 0.22uF | NONE | | | |
| 67-XXX-020-1-04 | | | | | 0.22uF | NONE | | | |
| 67-XXX-020-1-14 | | | .005mA | NONE | 0.47uF | NONE | | | |
| 67-XXX-020-1-06 | | | | | 0.22uF | NONE | | | |
| 67-XXX-020-4-12 | | | | | 0.22uF | NONE | | | |
| 67-XXX-020-4-04 | | | | | 0.22uF | NONE | | | |
| 67-XXX-020-4-14 | | | | | 0.47uF | NONE | | | |
| 67-XXX-020-4-06 | | | | | 0.22uF | NONE | | | |
| 67-XXX-040-0-12 | | 125 VAC | 4A | 0.04mA | 330pF | 0.22uF | NONE | 4.2mH | 45°C |
| 67-XXX-040-0-04 | | | | | | 0.22uF | NONE | | |
| 67-XXX-040-0-14 | | | | | | 0.47uF | NONE | | |
| 67-XXX-040-0-06 | | | | | | 0.22uF | NONE | | |
| 67-XXX-040-1-12 | | | | | | 0.22uF | NONE | | |
| 67-XXX-040-1-04 | | | | | | 0.22uF | NONE | | |
| 67-XXX-040-1-14 | | | | .005mA | NONE | 0.47uF | NONE | | |
| 67-XXX-040-1-06 | | | | | | 0.22uF | NONE | | |
| 67-XXX-040-4-12 | | | | | | 0.22uF | NONE | | |
| 67-XXX-040-4-04 | | | | | | 0.22uF | NONE | | |
| 67-XXX-040-4-14 | | | | | | 0.47uF | NONE | | |
| 67-XXX-040-4-06 | | | | | | 0.22uF | NONE | | |
| 67-XXX-060-0-12 | 6A | | 0.04mA | 330pF | 0.22uF | NONE | 1.6mH | 45°C | |
| 67-XXX-060-0-04 | | | | | 0.22uF | NONE | | | |
| 67-XXX-060-0-14 | | | | | 0.47uF | NONE | | | |
| 67-XXX-060-0-06 | | | | | 0.22uF | NONE | | | |
| 67-XXX-060-1-12 | | | | | 0.22uF | NONE | | | |
| 67-XXX-060-1-04 | | | | | 0.22uF | NONE | | | |
| 67-XXX-060-1-14 | | | .005mA | NONE | 0.47uF | NONE | | | |
| 67-XXX-060-1-06 | | | | | 0.22uF | NONE | | | |
| 67-XXX-060-4-12 | | | | | 0.22uF | NONE | | | |
| 67-XXX-060-4-04 | | | | | 0.22uF | NONE | | | |
| 67-XXX-060-4-14 | | | | | 0.47uF | NONE | | | |
| 67-XXX-060-4-06 | | | | | 0.22uF | NONE | | | |

Note: Test Voltage: 1500VAC one minute, line to ground
Insulation Resistance: 300 MΩ min. at 500VDC
Voltage Drop: 1V max. at rated current

Weight: 130g
Inlet: Compatible with IEC-320
B(S) = Bolt-in terminals or (Snap-in terminals)

* Substitute BSF or SSF for XXX
BSF - Bolt-In Switched and Fused
SSF - Snap-In Switched and Fused

Switched and Fused Filtered Power Entry Modules

For Medical or General Purpose Applications

Temperature Characteristics

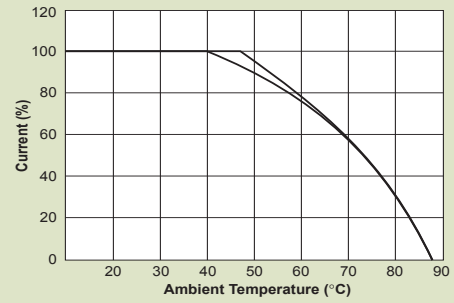

Dimensions 66/67-BSF Series

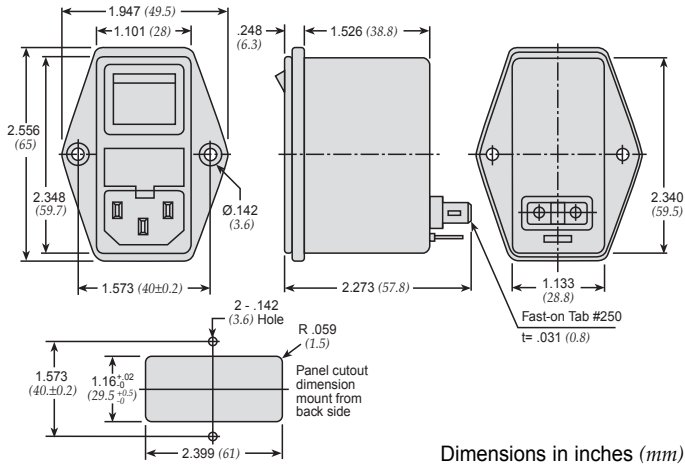

66/67-SSF Series

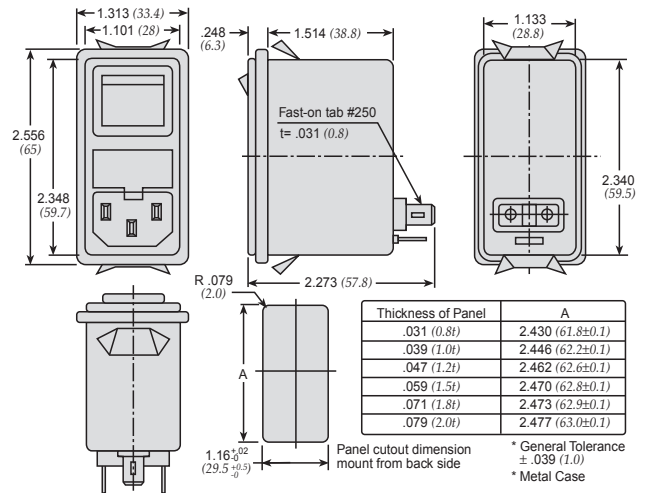

Common Mode

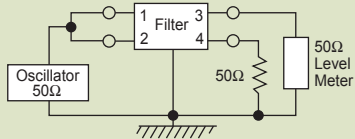

0.01 mA Leakage Current

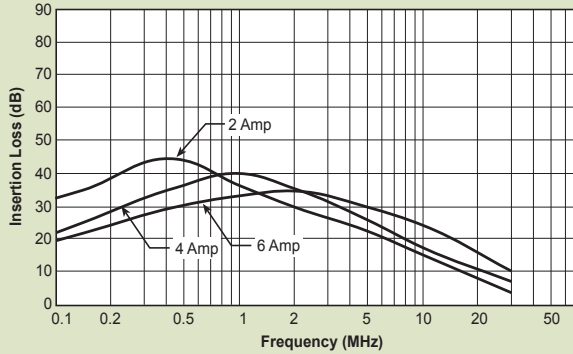

0.075 and 0.1 mA Leakage Current

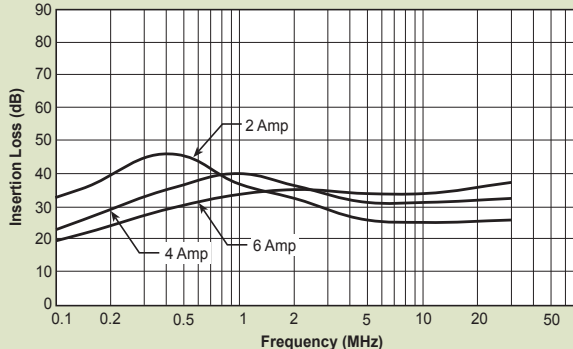

Normal Mode

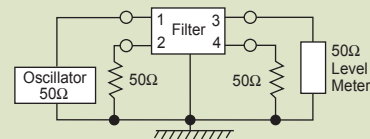

0.01 mA Leakage Current

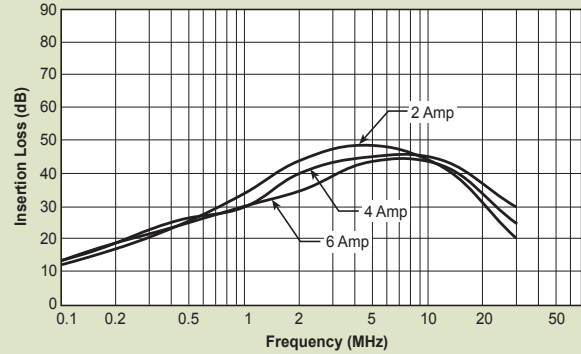

0.075 and 0.1 mA Leakage Current

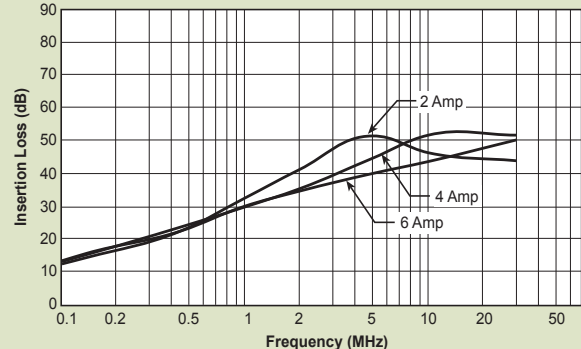

Switched and Fused Filtered Power Entry Modules

Dual Fuse for European Applications



68-BSF Series

Features

- Dual fuse for European applications
- Fuse holder and double pole power ON/OFF switch provides a convenient/compact package
- Suitable for products that must conform to FCC and FTZ requirements
- Meets over voltage category II of IEC 664 and complies with IEC 950
- Metal case provides effective EMI shielding
- IEC connector meets the safety standards of most certifying agencies
- Easy access fuse drawer
- Flange-mounted
- UL, CSA, and SEMKO approved
- Designed to be in accordance with VDE 0565, part 3
- Operating temperature: -25°C to +85°C (including temperature rise, see graph on page PF43)

Applications

- Computers and peripheral equipment
- Electronic equipment
- Digital equipment
- Measuring and testing instruments
- Telecommunications equipment

Circuit Diagram

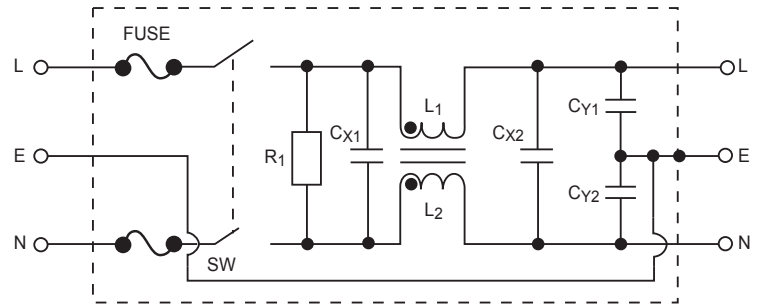

Specifications

| Model | Rated Voltage (@ 50/60Hz) | Rated Current | Leakage Current (Max.) | Capacitance | | | | Inductance (L ₁) | Temperature Rise (Max.) |
|-----------------|---------------------------|---------------|------------------------|-----------------|-----------------|-----------------|-----------------|------------------------------|-------------------------|
| | | | | C _{Y1} | C _{Y2} | C _{X1} | C _{X2} | | |
| 68-BSF-020-3-01 | 250VAC | 2A | 0.35mA | 2200pF | 2200pF | 0.1uF | 0.1uF | 10.5mH | 45°C |
| 68-BSF-020-3-04 | | | | | | 0.22uF | 0.22uF | | |
| 68-BSF-040-3-01 | | 4A | | | | 0.1uF | 0.1uF | 4.2mH | |
| 68-BSF-040-3-04 | | | | | | 0.22uF | 0.22uF | | |
| 68-BSF-060-3-01 | | 6A | | | | 1.6mH | 0.1uF | 0.1uF | |
| 68-BSF-060-3-04 | | | | | | | 0.22uF | 0.22uF | |

Note: Test Voltage 1500VAC one minute, line to ground
 Insulation Resistance: 300 MΩ min. at 500VDC
 Voltage Drop: 1V max. at rated current
 Weight: 130g
 Inlet: Compatible with IEC-320
 B(S) = Bolt-in terminals

Switched and Fused Filtered Power Entry Modules

Dual Fuse for European Applications

68-BSF Series

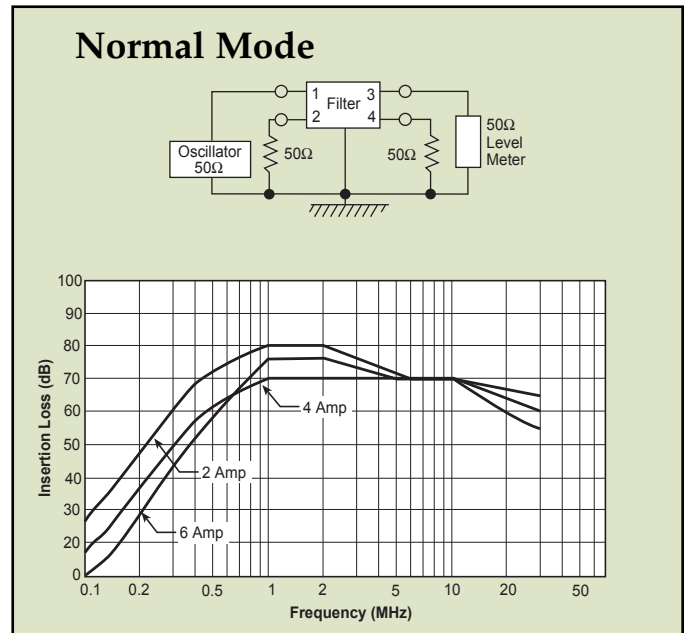
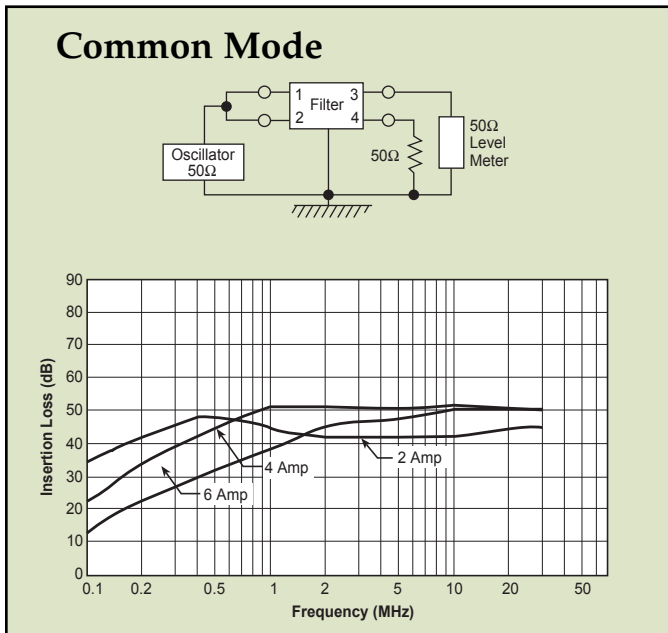
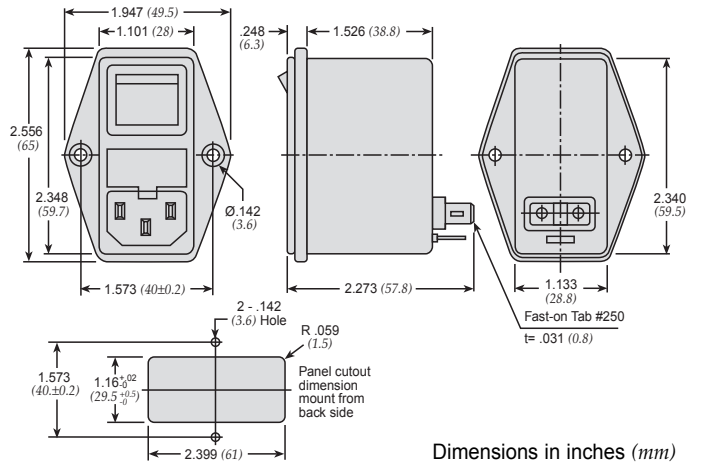
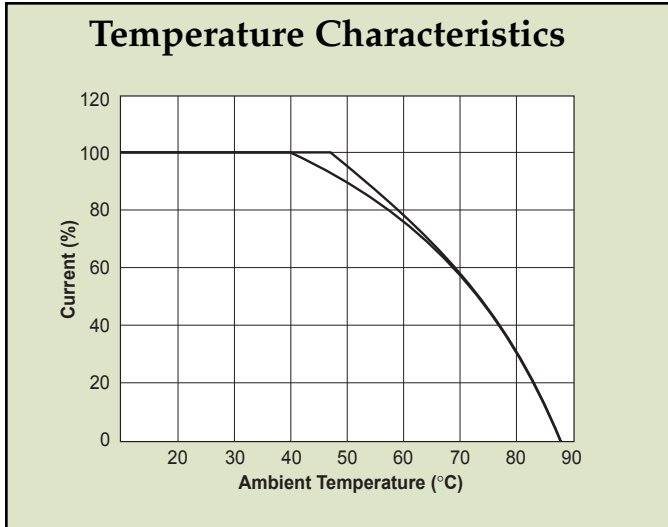

PCB Power Filters Miniature Printed Circuit Board

61-MPC Series



Tested and found to be
IAW VDE 0565 Part 3

Features

- Miniature general purpose PCB mounted filter
- Requires minimal PCB real estate space
- Low cost
- Designed for two wire cord systems
- For three wire cord systems, Y capacitors can be attached externally
- Operating temperature: -25°C to +85°C (including temperature rise, see graph on page PF45)

Applications

- Personal computers and peripherals
- Digital equipment
- Measuring instruments and medical equipment
- TV & VCR monitors and display units
- Home appliances



Circuit Diagram

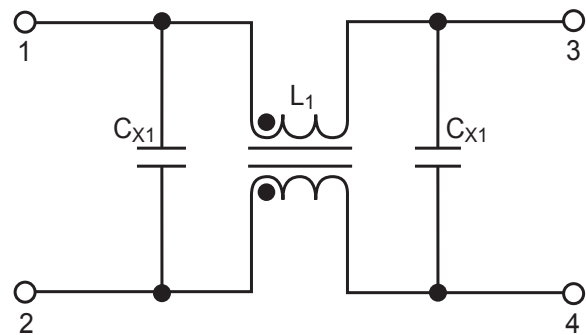

Specifications

| Model | Rated Voltage (@ 50/60Hz) | Rated Current | Leakage Current (Max.) | Capacitance | | Inductance (L ₁) | Temperature Rise (Max.) |
|-----------------|------------------------------|---------------|---------------------------|-----------------|-----------------|---------------------------------|----------------------------|
| | | | | C _{x1} | C _{x2} | | |
| 61-MPC-010-1-11 | 250VAC | 1A | 0.1mA | 0.1uF | 0.1uF | 11mH | 40°C |
| 61-MPC-016-1-11 | | 1.6A | | | | 6.0mH | |
| 61-MPC-025-1-11 | | 2.5A | | | | 2.4mH | |
| 61-MPC-036-1-11 | | 3.6A | | | | 1.2mH | |

Note: Test voltage: 1500VAC one minute, line to ground
Insulation resistance: 300 Mohm min. at 500VDC
Voltage drop: 1V max. at rated current
Weight: 17.5g

PCB Power Filters Miniature Printed Circuit Board

61-MPC Series

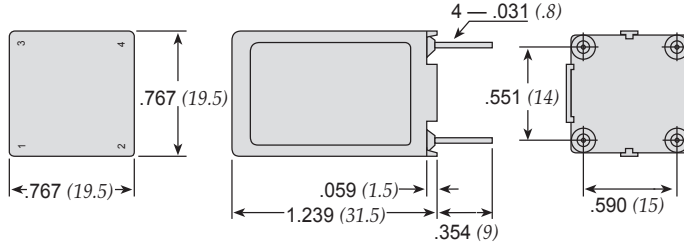

Dimensions in inches (mm)

Common Mode

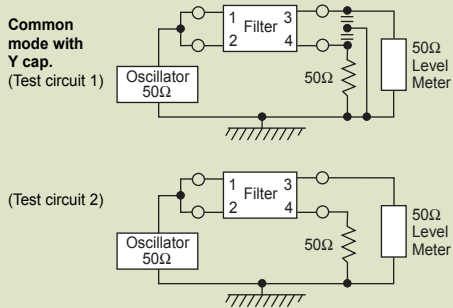

Temperature Characteristics

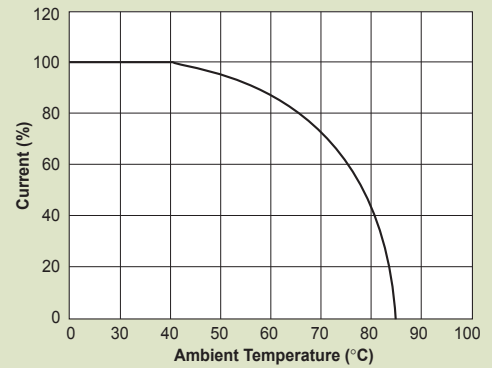

61-MPC

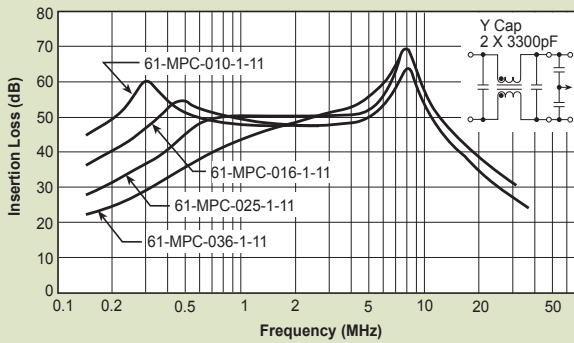

61-MPC

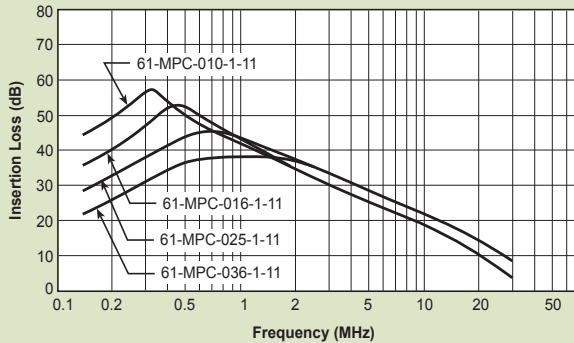

Normal Mode

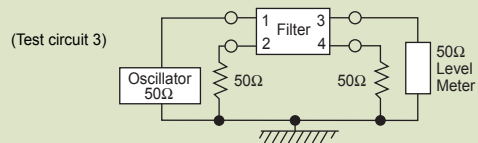

61-MPC

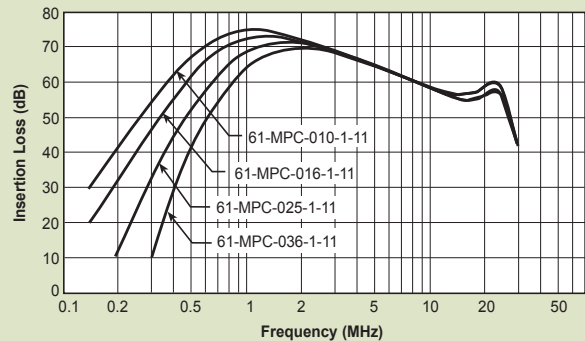

Power Entry Modules Bolt-in Right Angle Terminals

for PCB Applications

60-BPP Series



Tested and found to be
IAW VDE 0565 Part 3

Features

- Ideally suited for products that must conform to FCC part 15 regulations
- Metal case offers high performance
- Meets over voltage of IEC 664 category II and complies with IEC 950
- Uses IEC connector that meets most safety standards Solder lug, Fast-on tab styles available (see page PF18)
- PCB mounting style minimizes space and provides economical installation
- Operating temperature: -25°C to +85°C (including temperature rise, see graph on page PF47)
- UL approved low leakage version also available

Applications

- Digital equipment
- Personal computers and peripherals
- Measuring instruments
- Monitor and display units



Circuit Diagram

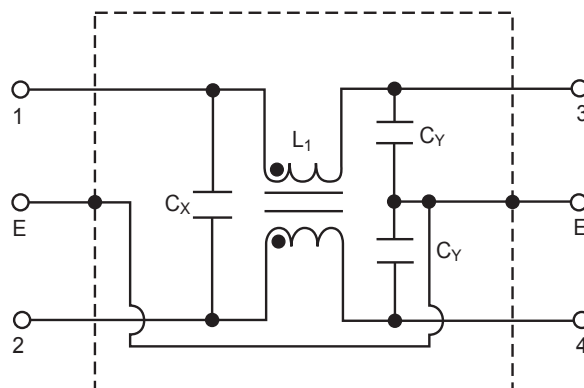

Specifications

| Model | Rated Voltage (@ 50/60Hz) | Rated Current | Leakage Current (Max.) | Capacitance | | Inductance (L ₁) | Temperature Rise (Max.) | |
|----------------|------------------------------|---------------|---------------------------|----------------|----------------|---------------------------------|----------------------------|------|
| | | | | C _Y | C _X | | | |
| 60-BPP-010-3-2 | 250VAC | 1A | 0.35mA | 2200pF | 0.022uF | 6.0mH | 30°C | |
| 60-BPP-010-3-4 | | | | | 0.047uF | | | |
| 60-BPP-010-5-2 | | | 0.50mA | 3300pF | 0.022uF | | | |
| 60-BPP-010-5-4 | | | | | 0.047uF | | | |
| 60-BPP-020-3-2 | | 2A | 0.35mA | 2200pF | 0.022uF | 2.4mH | | |
| 60-BPP-020-3-4 | | | | | 0.047uF | | | |
| 60-BPP-020-5-2 | | | 0.50mA | 3300pF | 0.022uF | | | |
| 60-BPP-020-5-4 | | | | | 0.047uF | | | |
| 60-BPP-030-3-2 | | 3A | 0.35mA | 2200pF | 0.022uF | 1.2mH | | |
| 60-BPP-030-3-4 | | | | | 0.047uF | | | |
| 60-BPP-030-5-2 | | | 0.50mA | 3300pF | 0.022uF | | | |
| 60-BPP-030-5-4 | | | | | 0.047uF | | | |
| 60-BPP-060-3-2 | | 6A | 0.35mA | 2200pF | 0.022uF | 0.53mH | | 45°C |
| 60-BPP-060-3-4 | | | | | 0.047uF | | | |
| 60-BPP-060-5-2 | | | 0.50mA | 3300pF | 0.022uF | | | |
| 60-BPP-060-5-4 | | | | | 0.047uF | | | |

Note: Test voltage: 1500VAC one minute, line to ground
 Insulation resistance: 300 Mohm min. at 500VDC
 Voltage drop: 1V max. at rated current
 Weight: 50g
 Input: Compatible with IEC-320

Power Entry Modules Bolt-in Right Angle Terminals for PCB Applications

60-BPP Series

Temperature Characteristics

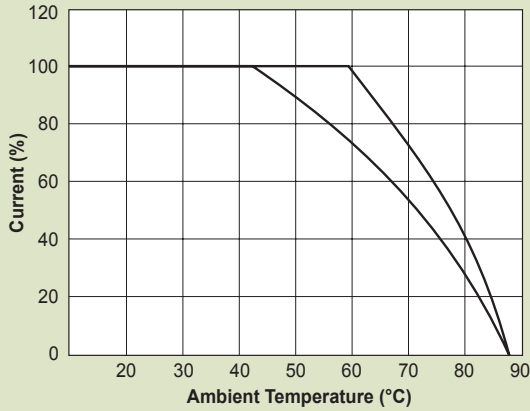

60-BPP PCB Mounting Type

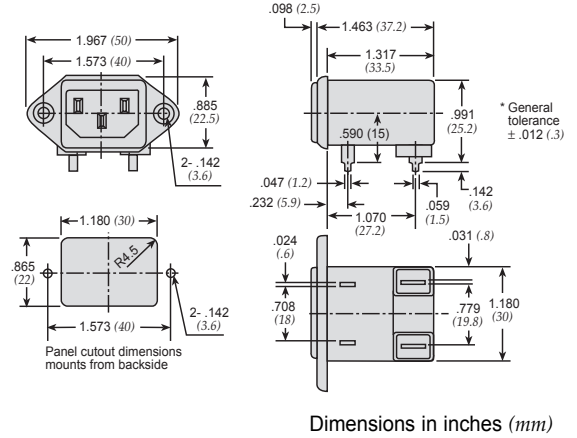

Common Mode

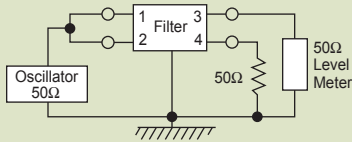

60-BPP-010;-020

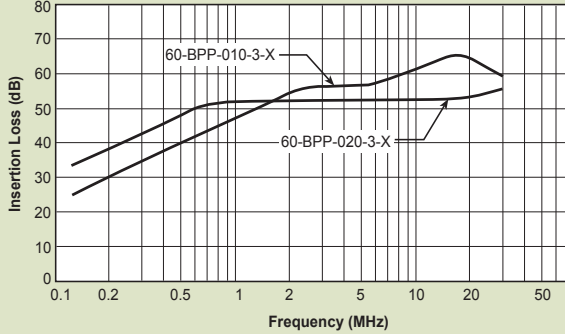

60-BPP-030;-060

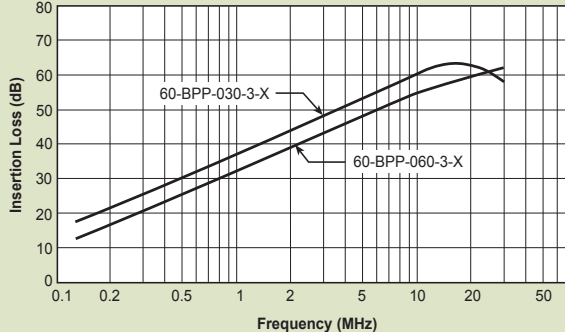

Normal Mode

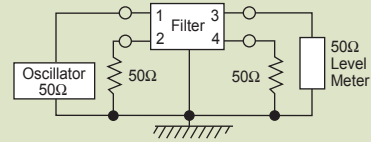

60-BPP-010;-020

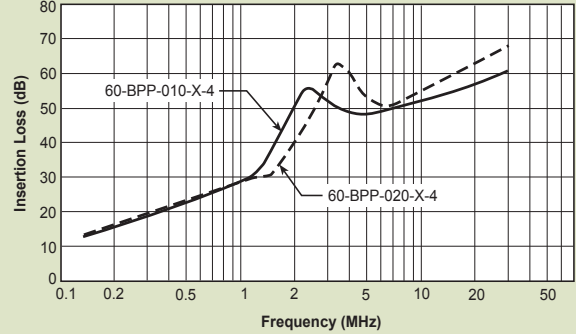

60-BPP-030;-060

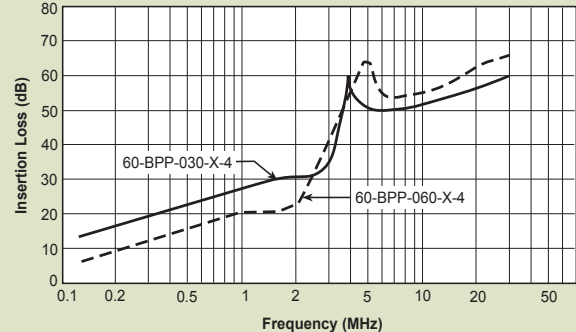

Power Entry Modules High Frequency Attenuation

Bolt-in for PCB Applications



60-BHP Series



Tested and found to be
IAW VDE 0565 Part 3

Features

- Ideally suited for products that must conform to FCC part 15 regulations
- Metal cased filter offers high performance
- Meets over voltage of IEC 664 category II and complies with IEC 950
- Solder lug, Fast-on tab styles available (see page PF20)
- PCB mounting minimizes space and provides economical installation
- Excellent filtering characteristics for high frequencies
- Earth coil standard
- Operating temperature: -25°C to +85°C (including temperature rise, see graph on page PF49)

Applications

- Digital equipment
- Personal computers and peripherals
- Measuring instruments
- Monitor and display units

Circuit Diagram

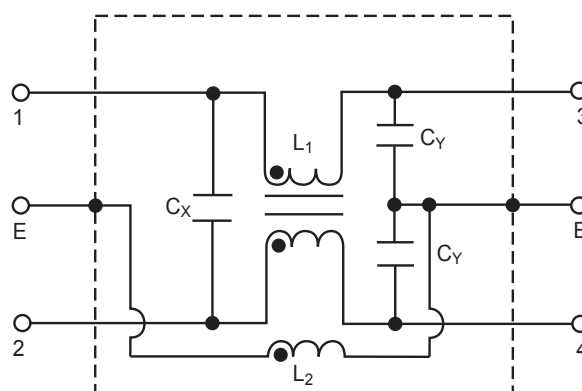

Specifications

| Model | Rated Voltage (@ 50/60Hz) | Rated Current | Leakage Current (Max.) | Capacitance | | Inductance | | Temperature Rise (Max.) |
|-----------------|------------------------------|---------------|---------------------------|----------------|----------------|-------------------|-------------------|-------------------------|
| | | | | C _Y | C _X | (L ₁) | (L ₂) | |
| 60-BHP-010-3-11 | 250VAC | 1A | 0.35mA | 2200pF±20% | 0.1uF±20% | 6mH | 18.3 uH | 30°C |
| 60-BHP-010-3-4 | | | | | .047uF±20% | | | |
| 60-BHP-010-5-11 | | | 0.50mA | 3300pF±20% | 0.1uF±20% | | | |
| 60-BHP-010-5-4 | | | | | .047uF±20% | | | |
| 60-BHP-020-3-11 | | 2A | 0.35mA | 2200pF±20% | 0.1uF±20% | 2.4mH | | |
| 60-BHP-020-3-4 | | | | | .047uF±20% | | | |
| 60-BHP-020-5-11 | | | 0.50mA | 3300pF±20% | 0.1uF±20% | | | |
| 60-BHP-020-5-4 | | | | | .047uF±20% | | | |
| 60-BHP-030-3-11 | | 3A | 0.35mA | 2200pF±20% | 0.1uF±20% | 1.2mH | | |
| 60-BHP-030-3-4 | | | | | .047uF±20% | | | |
| 60-BHP-030-5-11 | | | 0.50mA | 3300pF±20% | 0.1uF±20% | | | |
| 60-BHP-030-5-4 | | | | | .047uF±20% | | | |
| 60-BHP-060-3-11 | | 6A | 0.35mA | 2200pF±20% | 0.1uF±20% | 0.53mH | | 45°C |
| 60-BHP-060-3-4 | | | | | .047uF±20% | | | |
| 60-BHP-060-5-11 | | | 0.50mA | 3300pF±20% | 0.1uF±20% | | | |
| 60-BHP-060-5-4 | | | | | .047uF±20% | | | |

Note: Test voltage: 1500VAC one minute, line to ground
 Insulation resistance: 300 Mohm min. at 500VDC
 Voltage drop: 1V max. at rated current
 Weight: 50g
 Input: Compatible with IEC-320

Power Entry Modules High Frequency Attenuation

Bolt-in for PCB Applications

60-BHP Series

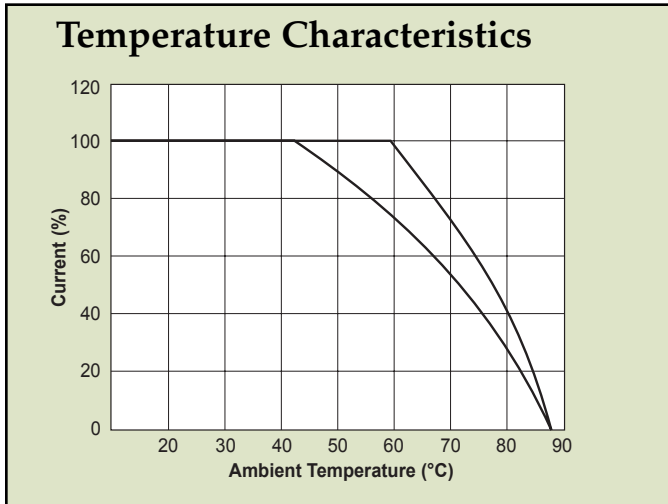

60-BHP PCB Mounting Type

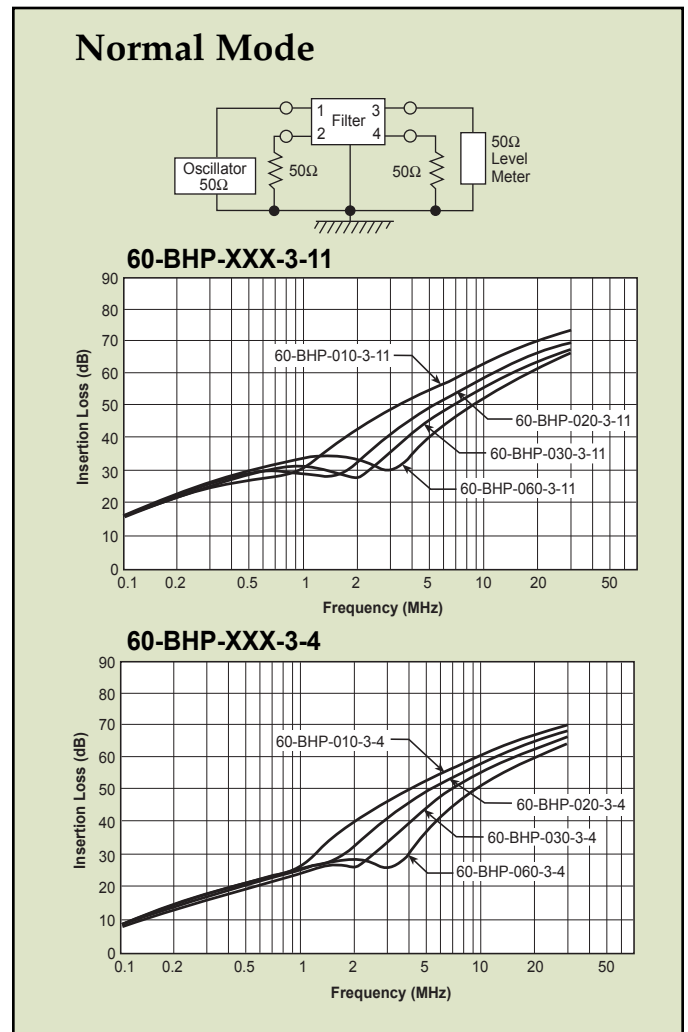
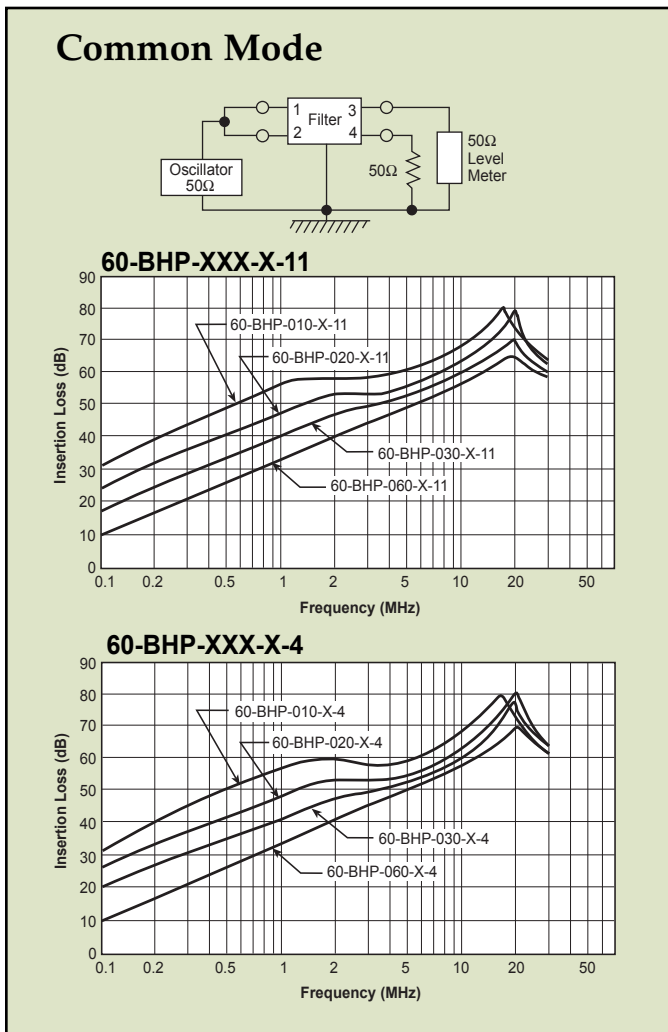
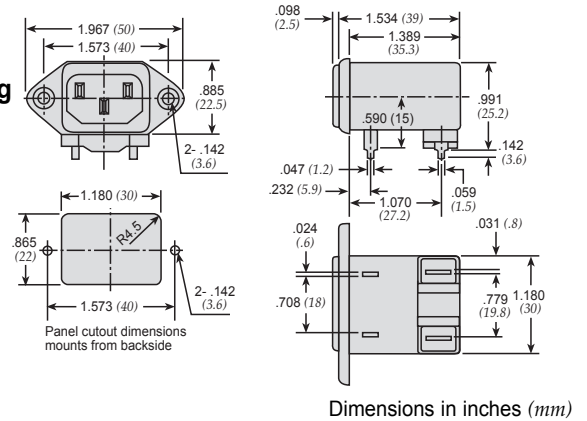

Power Line Filters Appliance Filters



11-MPC Series

Features

- Miniature general purpose PCB mounted filter
- Requires minimal PCB real estate space
- Low cost
- Operating temperature: -25°C to +70°C
- Two forms of cases are available: metal case and plastic case

Applications

- Personal computers and peripherals
- Digital equipment
- Measuring instruments and medical equipment
- TV & VCR monitors and display units
- Home appliances

Circuit Diagram

Circuit 1

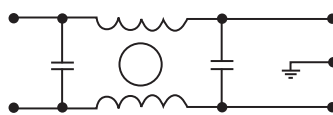

Circuit 2

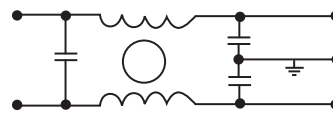

Circuit 3

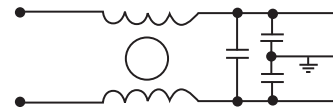

Circuit 4

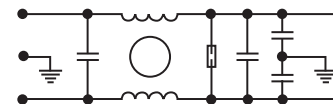

Specifications

| Model | Rated Voltage (@ 50/60Hz) | Rated Current | Leakage Current (Max.) | Circuit Diagram | Figure | Temperature Rise (Max.) | |
|----------------|---------------------------|---------------|------------------------|-----------------|--------|-------------------------|---|
| 11-MPC-001-2-B | 120/250VAC | 1A | 0.50mA | 1 | A1 | 30°C | |
| 11-MPC-001-5-A | | | | A | | | |
| 11-MPC-001-5-B | | | | A1 | | | |
| 11-MPC-002-5-B | | 2A | | D | 3 | | E |
| 11-MPC-002-5-D | | | | | | | |
| 11-MPC-003-5-E | | | | | | | |
| 11-MPC-006-5-B | | 6A | | A1 | 2 | | C |
| 11-MPC-006-5-C | | | | | | | |
| 11-MPC-016-5-B | | | | | | | |

Note: Test voltage: 1500VAC one minute, line to ground
 Insulation resistance: 300 Mohm min. at 500VDC
 Voltage drop: 1V max. at rated current
 Weight: 17.5g

PCB Power Filters Miniature Printed Circuit Board

11-MPC Series

Figure A

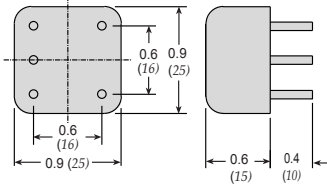

Figure A1

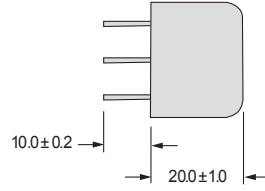

Figure B

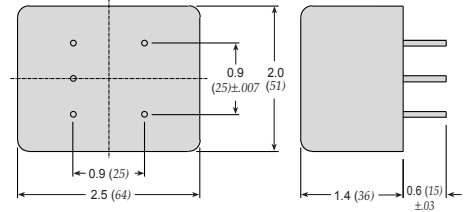

Figure C

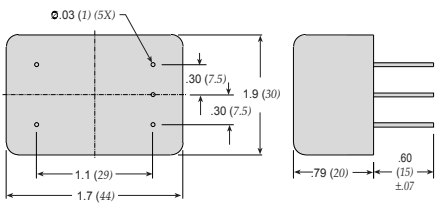

Figure D

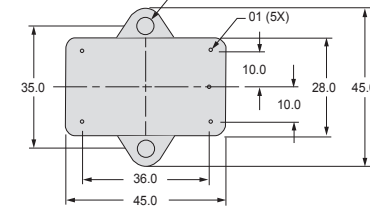
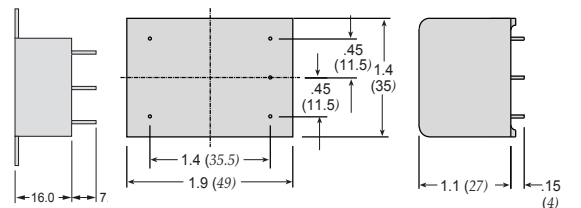
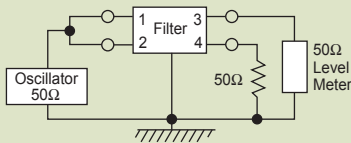

Figure E



Dimensions in inches (mm)

Common Mode



11-MPC-001;-002

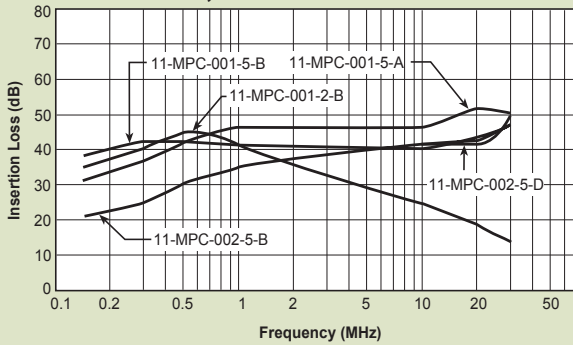

11-MPC-003;-006;-016

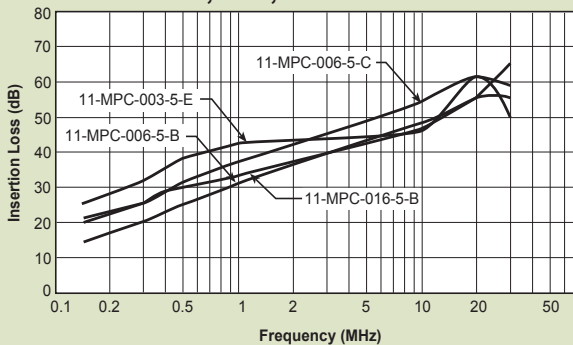

Normal Mode

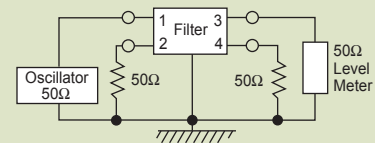

11-MPC-001;-002

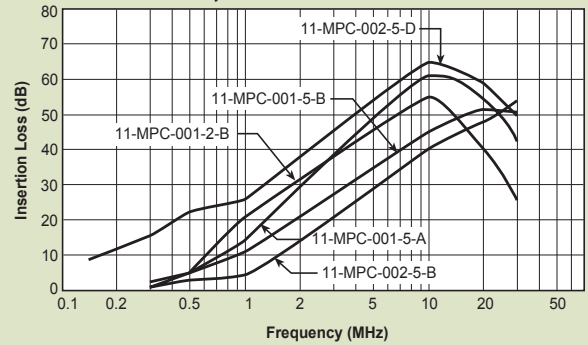

11-MPC-003;-006;-016

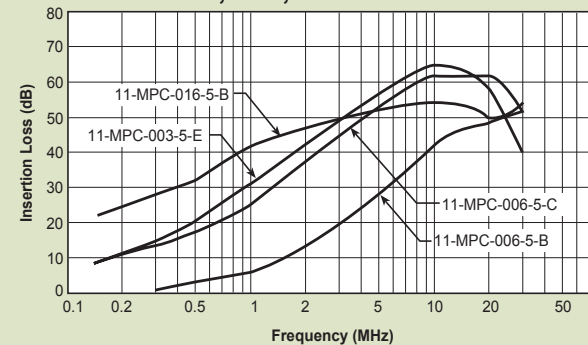

Power Line Filters Appliance Filters

62-AL/62-AC Series



Tested and found to be
IAW VDE 0565 Part 3

Features

- Low-cost plastic case
- Compact design requires minimal real estate space
- Suitable for products that must conform to FCC regulations
- Wide variety of circuit and filtering options
- Good filtering characteristics for both normal mode and common mode
- Epoxy molded for reliability
- Operating temperature: -25°C to +85°C (including temperature rise, see graph on page PF53)

Applications

- Personal computers and peripherals
- Digital equipment
- Industrial equipment
- Vending machines
- Home appliances
- Office equipment

Specifications

| Model* | Rated Voltage (@ 50/60Hz) | Rated Current | Leakage Current (Max.) | Capacitance | | Inductance (L ₁) | Temperature Rise (Max.) | | |
|-----------------|------------------------------|---------------|---------------------------|----------------|----------------|---------------------------------|----------------------------|--------|--------|
| | | | | C _Y | C _X | | | | |
| 62-AFL-010-3-11 | 250VAC | 1.0A | 0.35mA | 2200pF | 0.1uF | 11.0mH | 40°C | | |
| 62-AFC-010-3-11 | | | 0.50mA | 3300pF | | | | | |
| 62-AFL-010-5-11 | | | 0.35mA | 2200pF | | | | | |
| 62-AFC-010-5-11 | | | | 3300pF | | | | | |
| 62-AFL-016-3-11 | | 1.6A | 0.35mA | 2200pF | | 6.0mH | | | |
| 62-AFC-016-3-11 | | | | 3300pF | | | | | |
| 62-AFL-016-5-11 | | 0.35mA | 0.50mA | 2200pF | | 2.4mH | | | |
| 62-AFC-016-5-11 | | | | 3300pF | | | | | |
| 62-AFL-030-3-11 | | 3.0A | 0.35mA | 2200pF | | 1.0mH | | | |
| 62-AFC-030-3-11 | | | | 3300pF | | | | | |
| 62-AFL-030-5-11 | | 0.35mA | 0.50mA | 2200pF | | 0.53mH | | | |
| 62-AFC-030-5-11 | | | | 3300pF | | | | | |
| 62-AFL-045-3-11 | | 4.5A | 0.35mA | 2200pF | | | | | |
| 62-AFC-045-3-11 | | | | 3300pF | | | | | |
| 62-AFL-045-5-11 | | 0.35mA | 0.50mA | 2200pF | | | | | |
| 62-AFC-045-5-11 | | | | 3300pF | | | | | |
| 62-AFL-060-3-11 | | 6.0A | 0.35mA | 2200pF | | | | | |
| 62-AFC-060-3-11 | | | | 3300pF | | | | | |
| 62-AFL-060-5-11 | | | | 0.35mA | | | | 0.50mA | 2200pF |
| 62-AFC-060-5-11 | | | | | | | | | 3300pF |

Note: All types are designed to meet the requirement of UL 1283, CSA 22.2. VDE 0565-3
 Test voltage: 1500VAC one minute, line to ground
 Insulation resistance: 300 Mohm min. at 500VDC
 Voltage drop: 1V max.

* Available with bleeder resistor
 Replace F with R for part number

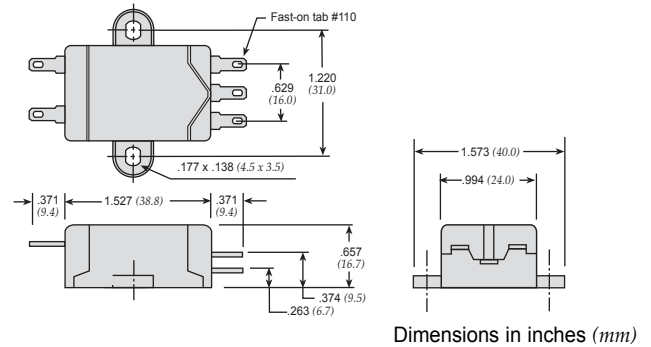

Circuit Diagrams

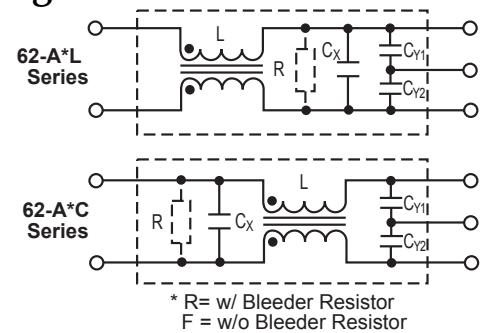

Power Line Filters Appliance Filters

62-AL/62-AC Series

Common Mode

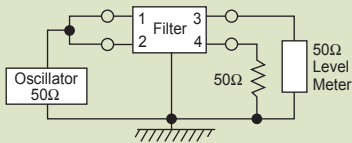

62-AFL-xxx-3-11

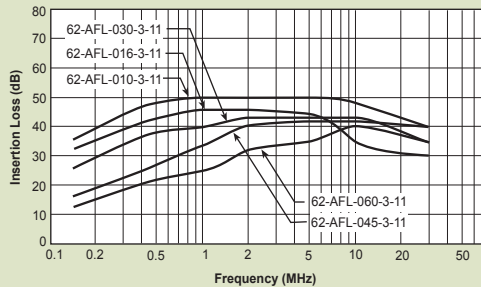

62-AFC-xxx-3-11

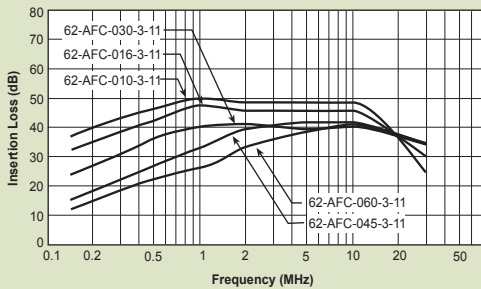

62-AFL-xxx-5-11

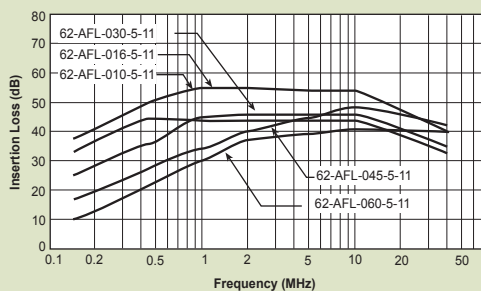

62-AFC-xxx-5-11

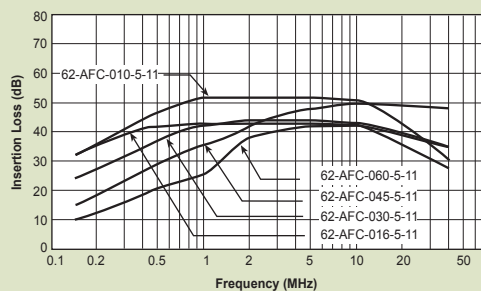

Temperature Characteristics

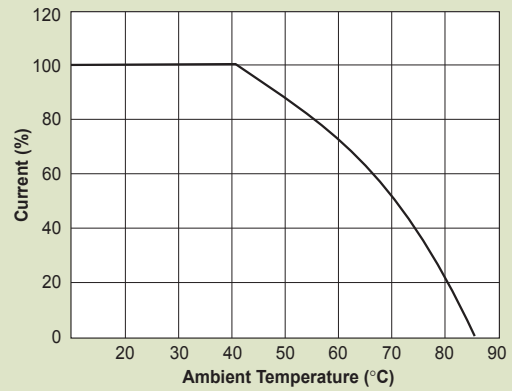

Normal Mode

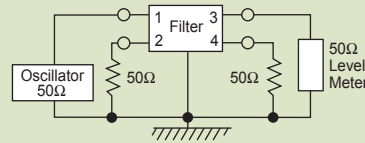

62-AFL-XXX-3-11

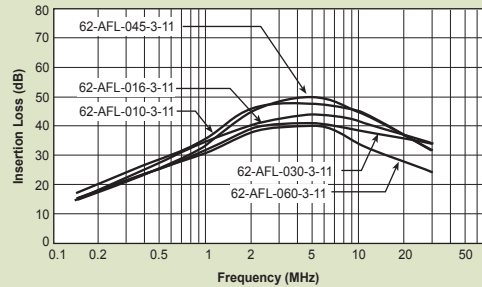

62-AFC-xxx-3-11

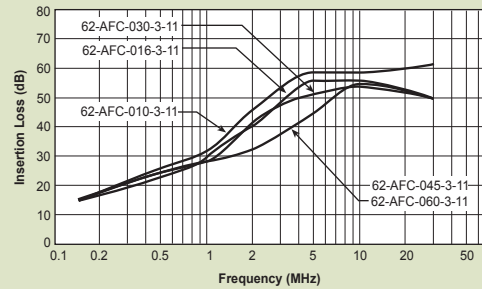

62-AFL-xxx-5-11

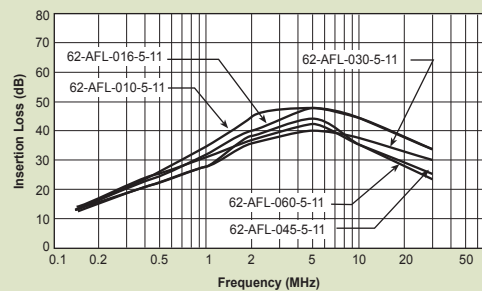

62-AFC-xxx-5-11

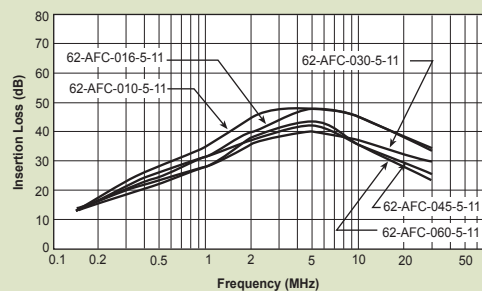

Power Line Filters Single Stage

62-PPF/PQF/PRF Series



Tested and found to be
IAW VDE 0565 Part 3

Features

- Low-cost plastic case
- Compact design requires minimal real estate space
- Suitable for products that must conform to FCC and FTZ regulations
- Wide variety of circuit and filtering options
- Good filtering characteristics for both normal mode and common mode
- Epoxy molded for reliability
- Operating temperature: -25°C to +85°C (including temperature rise, see graph on page PF55)

Applications

- Personal computers and peripherals
- Digital equipment
- Industrial equipment
- Vending machines
- Office equipment



Circuit Diagrams

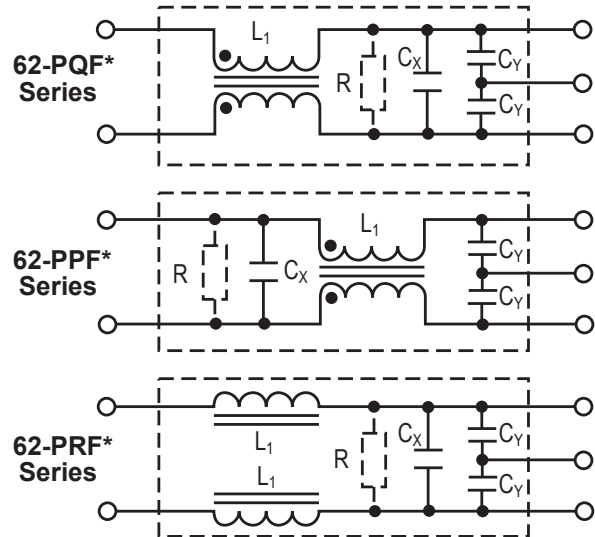

* Bleeder Resistor is available only for
62-P(Q/R/P)F-XXX-X-12

Specifications

| Model | Rated Voltage (@ 50/60Hz) | Rated Current | Leakage Current (Max.) | Capacitance | | Inductance (L ₁) | Temperature Rise (Max.) | | | | | | | | | | | | | | |
|-----------------|------------------------------|---------------|---------------------------|----------------|----------------|---------------------------------|----------------------------|--------|--------|--------|--------|-------|------|--------|--------|-------|------|--------|-------|------|------|
| | | | | C _Y | C _X | | | | | | | | | | | | | | | | |
| 62-PQF-020-5-11 | 250VAC | 2A | 0.50mA | 3300pF | 0.1uF | 15mH | 30°C | | | | | | | | | | | | | | |
| 62-PQF-020-5-12 | | | | | .22uF | | | | | | | | | | | | | | | | |
| 62-PPF-020-5-11 | | | | | 0.1uF | | | 8mH | | | | | | | | | | | | | |
| 62-PPF-020-5-12 | | | | | .22uF | | | | | | | | | | | | | | | | |
| 62-PQF-030-5-11 | | | | | 0.1uF | | | | 2.1mH | | | | | | | | | | | | |
| 62-PQF-030-5-12 | | | | | .22uF | | | | | | | | | | | | | | | | |
| 62-PPF-030-5-11 | | 0.1uF | | | 486uH | | | | | | | | | | | | | | | | |
| 62-PPF-030-5-12 | | .22uF | | | | | | | | | | | | | | | | | | | |
| 62-PQF-060-5-11 | | 0.1uF | | | | 181uH | | | | | | | | | | | | | | | |
| 62-PQF-060-5-12 | | .22uF | | | | | | | | | | | | | | | | | | | |
| 62-PPF-060-5-11 | | 0.1uF | | | | | | 97uH | | | | | | | | | | | | | |
| 62-PPF-060-5-12 | | .22uF | | | | | | | | | | | | | | | | | | | |
| 62-PRF-010-5-11 | | 1A | | | 3A | | | | 0.50mA | 3300pF | 0.1uF | 486uH | 30°C | | | | | | | | |
| 62-PRF-010-5-12 | | .22uF | | | | | | | | | | | | | | | | | | | |
| 62-PRF-020-5-11 | | 2A | | | | 0.50mA | | | | | 3300pF | | | 3300pF | 0.1uF | 181uH | 30°C | | | | |
| 62-PRF-020-5-12 | | .22uF | | | | | | | | | | | | | | | | | | | |
| 62-PRF-030-5-11 | | 3A | | | | | | 0.50mA | | | | | | | 3300pF | | | 3300pF | 0.1uF | 97uH | 30°C |
| 62-PRF-030-5-12 | | .22uF | | | | | | | | | | | | | | | | | | | |

Note: All types are designed to meet the requirement of UL 1283, CSA 22.2, VDE 0565-3

Test voltage: 1500VAC one minute, line to ground
 Insulation resistance: 300 Mohm min. at 500VDC
 Voltage drop: 1V max. (except 62-PRF-010-5-11) at rated current
 62-PRF-010-5-11: 1.5V max. at rated current
 Weight: 62-PPF & PQF Series: 2.11 ounces (60 grams)
 62-PRF Series: 1.76 ounces (50 grams)

Power Line Filters Single Stage

62-PPF/PQF/PRF Series

Temperature Characteristics

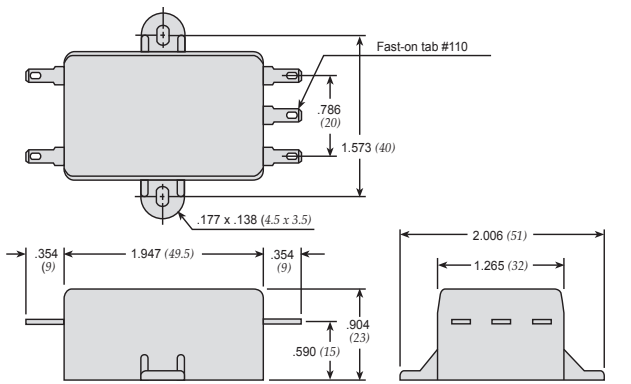
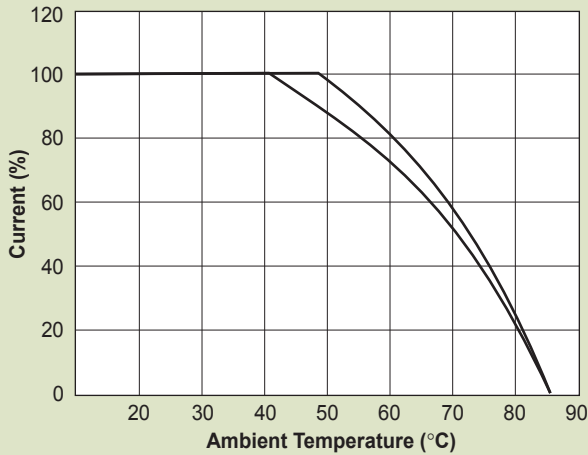

Also available with .250 Fast-ons

Dimensions in inches (mm)

Normal Mode

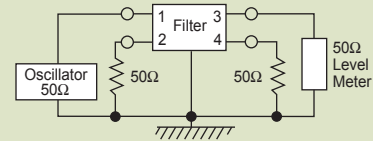

62-PQF Series

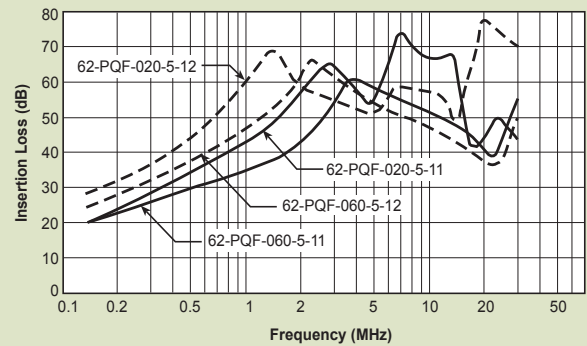

62-PPF Series

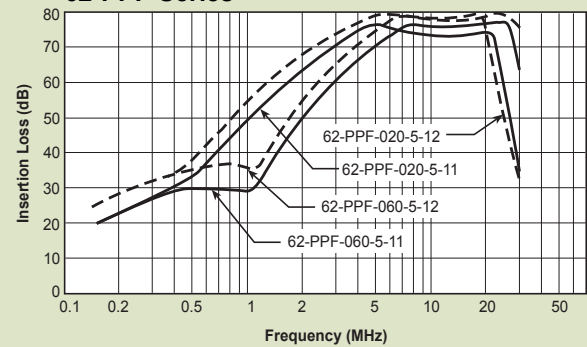

Common Mode

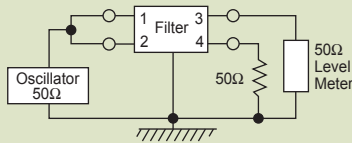

62-P(Q/R)F Series

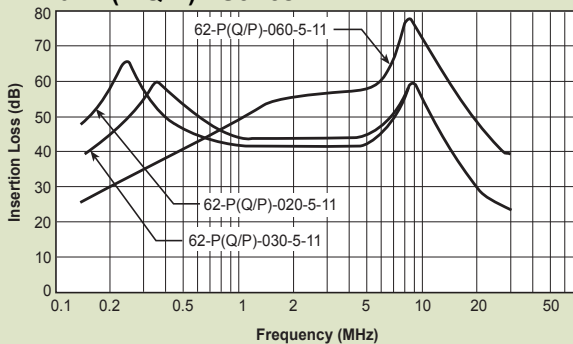

62-PRF Series

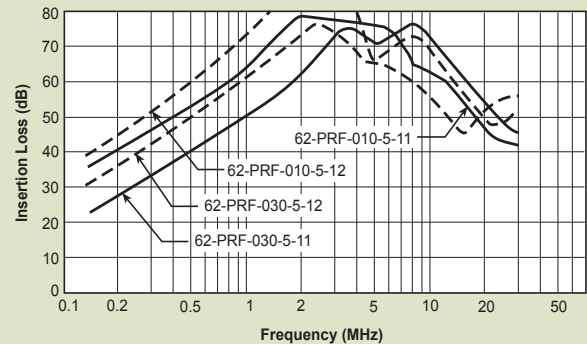

Power Line Filters Single Stage Wire Leads



62-PML Series



Tested and found to be
IAW VDE 0565 Part 3

Features

- Compact design requires minimal real estate space
- Suitable for products that must conform to FCC and FTZ regulations
- Excellent attenuation for high voltage impulse
- Metal case provides effective shielding
- Excellent filtering characteristics for both normal mode and common mode
- Structure provides effective shielding for noise generated externally and internally
- Operating temperature: -25°C to +85°C (including temperature rise, see graph on page PF57)

Applications

- Digital equipment
- Personal computers and peripherals
- Measuring instruments
- Medical equipment
- Factory automation equipment

Circuit Diagram

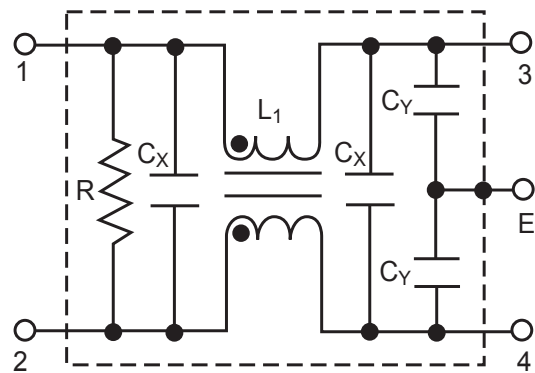

Specifications

| Model | Rated Voltage (@ 50/60Hz) | Rated Current | Leakage Current (Max.) | Capacitance | | Inductance (L ₁) | Temperature Rise (Max.) |
|-----------------|---------------------------|---------------|------------------------|----------------|----------------|------------------------------|-------------------------|
| | | | | C _Y | C _X | | |
| 62-PML-015-3-11 | 250VAC | 1.5A | 0.35mA | 2200pF | 0.1uF | 10.0mH | 30°C |
| 62-PML-015-5-11 | | | 0.50mA | 3300pF | | 4.3mH | |
| 62-PML-030-3-11 | | 3A | 0.35mA | 2200pF | | | |
| 62-PML-030-5-11 | | | 0.50mA | 3300pF | | | |
| 62-PML-050-3-11 | | 5A | 0.35mA | 2200pF | | | |
| 62-PML-050-5-11 | | | 0.50mA | 3300pF | | | |

Note: All types are designed to meet the requirement of UL 1283, CSA 22.2, VDE 0565-3
 Test voltage: 1500VAC one minute, line to ground
 Insulation resistance: 300 Mohm min. at 500VDC
 Voltage drop: 1V max. at rated current
 Weight: 62-PML-015 Series: 3.06 ounces (87 grams)
 62-PML-030 Series: 3.17 ounces (90 grams)
 62-PML-050 Series: 3.28 ounces (93 grams)
 Discharge time: 0.4 sec. max.

Power Line Filters Single Stage Wire Leads

62-PML Series

Temperature Characteristics

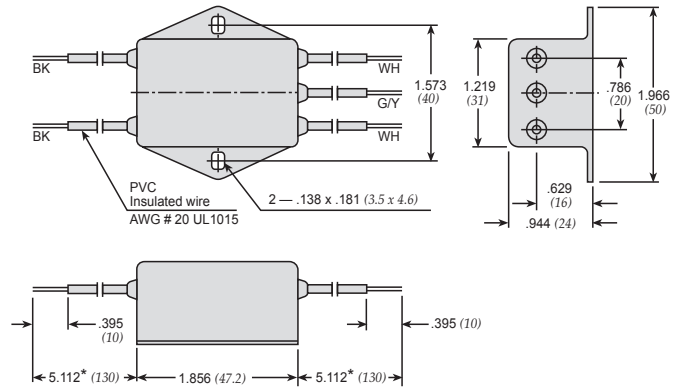
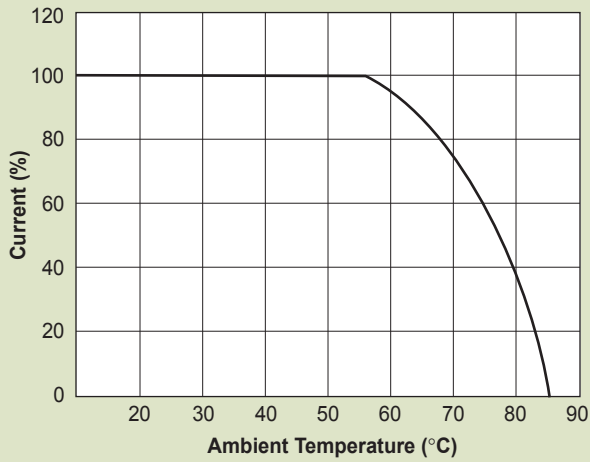

* Custom lengths available upon request. Dimensions in inches (mm)

Common Mode

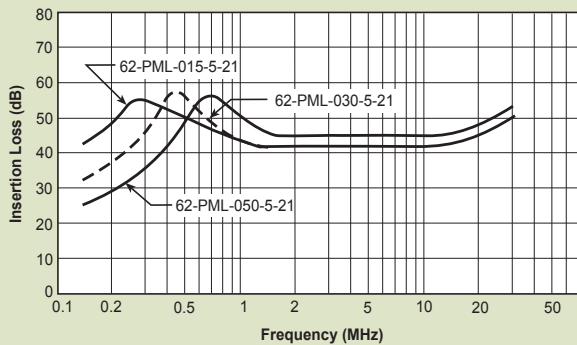
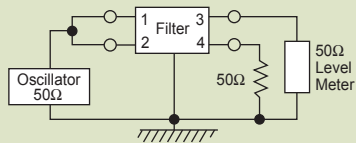

Normal Mode

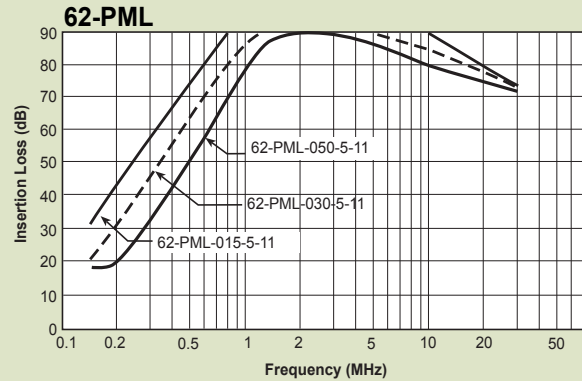
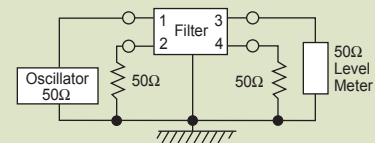

Power Line Filters Single Stage Wire Leads

for Medical Purpose Applications

12-PML & 12-PMF Series



Features

- Compact design requires minimal real estate space
- Suitable for products that must conform to FCC and FTZ regulations
- Excellent attenuation for high voltage impulse
- Metal case provides effective shielding
- Excellent filtering characteristics for both normal mode and common mode
- Structure provides effective shielding for noise generated externally and internally
- Operating temperature: -25°C to +70°C
- Low leakage current

Applications

- Digital equipment
- Personal computers and peripherals
- Measuring instruments
- Medical equipment
- Factory automation equipment



Circuit Diagram

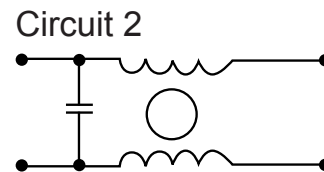
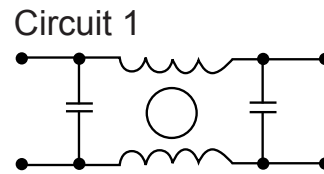

Specifications

| Model | Rated Voltage (@ 50/60Hz) | Rated Current | Leakage Current (Max.) | Circuit Diagram | Figure | Temperature Rise (Max.) |
|----------------|---------------------------|---------------|------------------------|-----------------|--------|-------------------------|
| 12-PML-001-2-A | 120/250VAC | 1A | 5uA | 1 | A | 30°C |
| 12-PML-002-2-A | | 2A | | | | |
| 12-PML-006-2-A | | 6A | | | | |
| 12-PML-010-2-A | | 10A | | 2 | B | |
| 12-PMF-001-2-B | | 1A | | | | |
| 12-PMF-002-2-B | | 2A | | | | |
| 12-PMF-006-2-B | | 6A | | 1 | C | |
| 12-PML-001-2-C | | 1A | | | | |

Note: All types are designed to meet the requirement of UL 1283, CSA 22.2. VDE 0565-3
 Test voltage: 1500VAC one minute, line to ground
 Insulation resistance: 300 Mohm min. at 500VDC
 Voltage drop: 1V max. at rated current
 Discharge time: 0.4 sec. max.

Power Line Filters Single Stage Wire Leads

for Medical Purpose Applications

12-PML & 12-PMF Series

Figure A

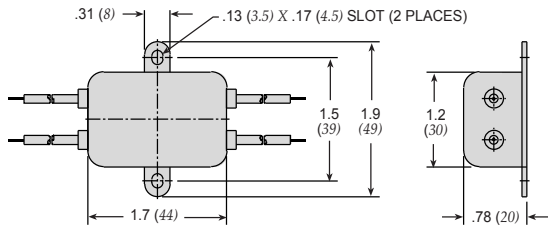

Figure C

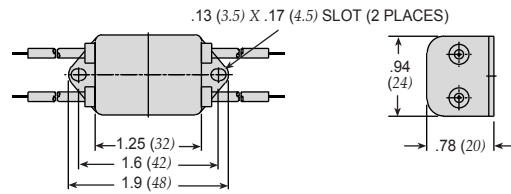
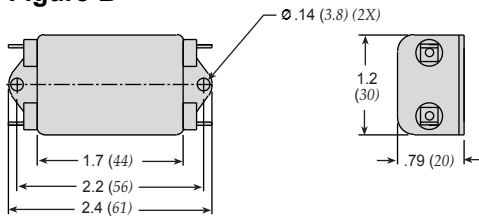
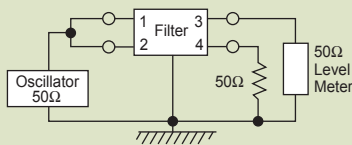

Figure B



Dimensions in inches (mm)

Common Mode



12-PML-001;-002;-006;-010

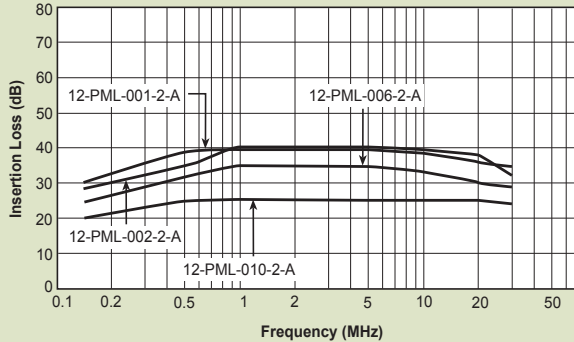

12-PMF-001;-002;-006;-010

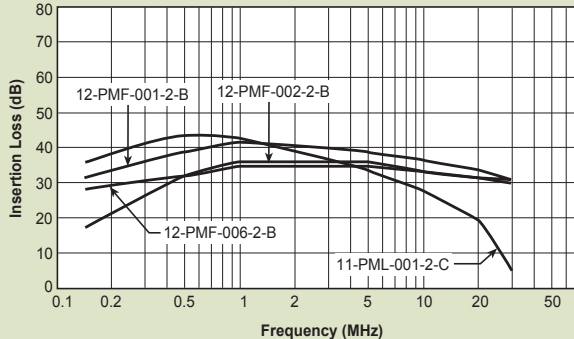

Normal Mode

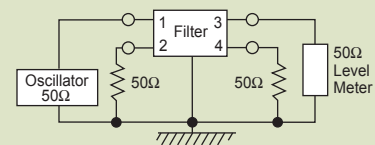

12-PML-001;-002;-006;-010

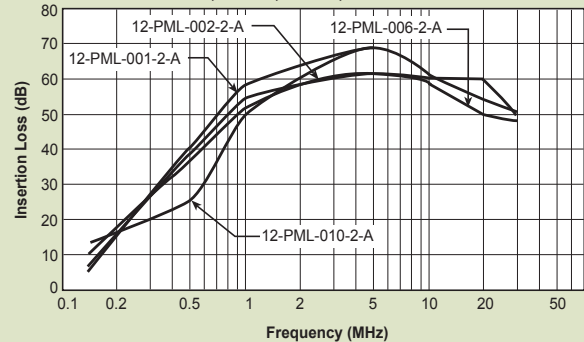

12-PMF-001;-002;-006;-010

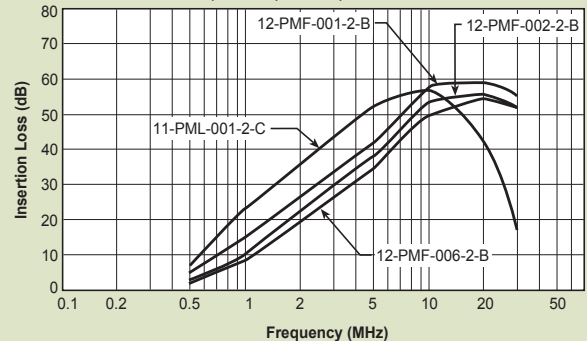

Power Line Filters Single Stage



62-LMF & LMB Series



Tested and found to be
IAW VDE 0565 Part 3

Features

- Space saving, compact designs
- Suitable for products that must conform to FCC and FTZ regulations
- Excellent filtering characteristics for both normal mode and common mode
- Structure provides effective shielding for noise generated externally and internally
- Metal case provides effective shielding
- Rugged construction
- Operating temperature: -25°C to +85°C (including temperature rise, see graph on page PF61)

Applications

- Digital equipment
- Office automation equipment, such as copy and fax machines
- Computers and peripherals
- Instrumentation and controls

Circuit Diagram

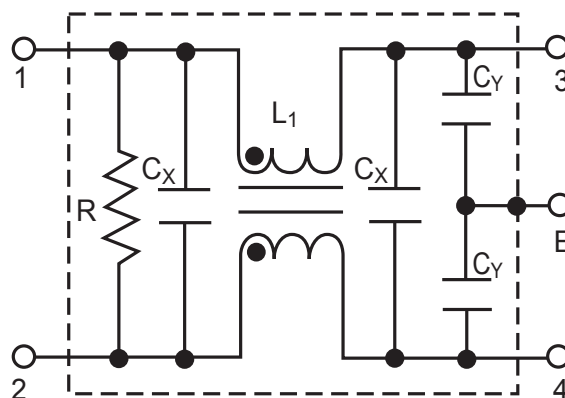

Specifications

| Model* | Rated Voltage (@ 50/60Hz) | Rated Current | Leakage Current (Max.) | Capacitance | | Inductance (L ₁) | Temperature Rise (Max.) | |
|-----------------|---------------------------|---------------|------------------------|----------------|----------------|------------------------------|-------------------------|-------|
| | | | | C _Y | C _X | | | |
| 62-LMB-030-5-11 | 250VAC | 3A | 0.50mA | 3300pF | 0.1uF | 14mH | 45°C | |
| 62-LMF-030-5-11 | | 5A | | | 0.1uF & .22uF | 7.0mH | | |
| 62-LMB-050-5-11 | | | | | 8A | .22uF | | 4.2mH |
| 62-LMF-050-5-11 | | 10A | | | | .33uF | | 2.2mH |
| 62-LMB-080-5-11 | | | | | .33uF | 2.2mH | | 2.2mH |
| 62-LMF-080-5-11 | | | | | | | | |
| 62-LMB-100-5-11 | | | | | .33uF | 2.2mH | | 2.2mH |
| 62-LMF-100-5-11 | | .33uF | | | | | | |

Note: Test voltage: 1500VAC one minute, line to ground
 Insulation resistance: 300 Mohm min. at 500VDC
 Voltage drop: 1V max. at rated current
 Discharge time: 0.4 sec. max.
 Weight: 5.3 ounces (150 grams)

*62-LMF - designates Fast-on terminals
 62-LMB - designates Bolt-in terminals
 62-LML - wire lead in/outputs also available

Power Line Filters Single Stage

62-LMF & LMB Series

Temperature Characteristics

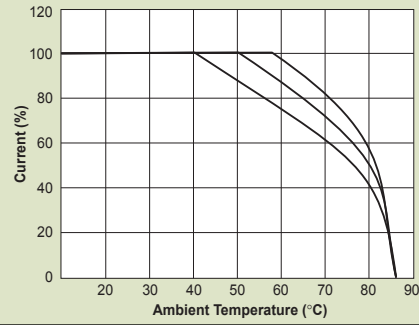

62-LMB

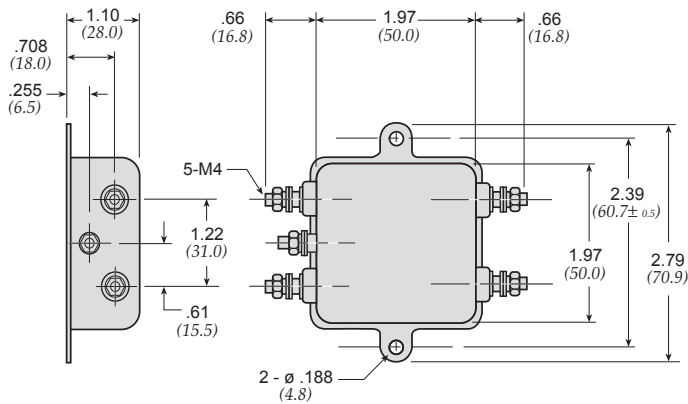

62-LMF

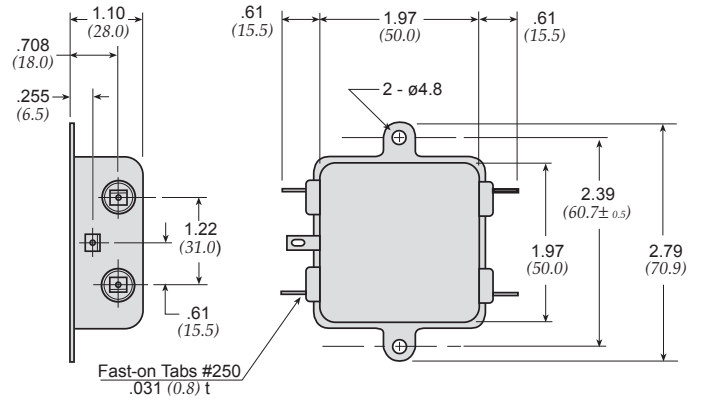

Dimensions in inches (mm)

Common Mode

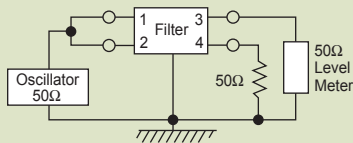

Normal Mode

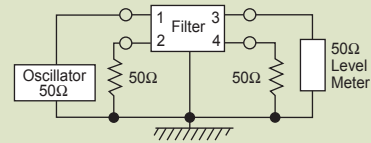

62-LMF & LMB

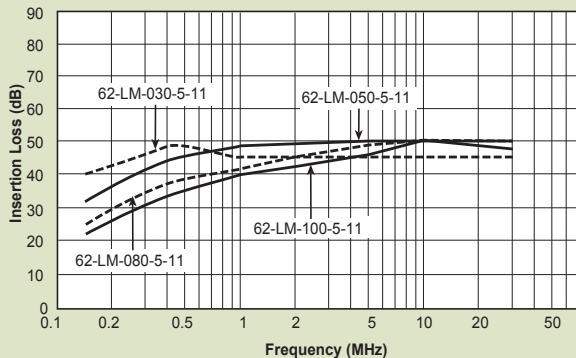

62-LMF & LMB

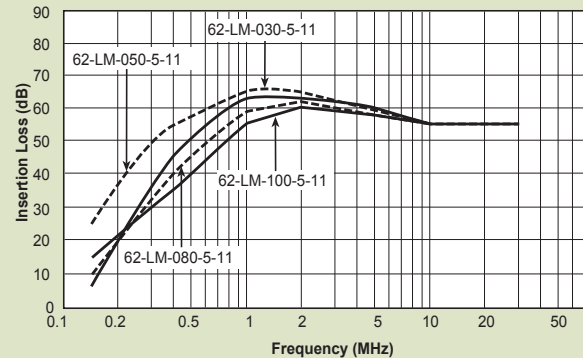

Power Line Filters Single Stage

62-PMF & PMB Series



Tested and found to be
IAW VDE 0565 Part 3

Features

- Space-saving, compact designs
- Suitable for products that must conform to FCC regulations
- Excellent attenuation for high voltage impulse
- Metal case provides effective EMI shielding
- Excellent filtering characteristics for both normal mode and common mode
- Epoxy molded for internal component reliability
- Structure provides effective shielding for noise generated externally and internally
- Operating temperature: -25°C to +85°C (including temperature rise, see graph on page PF63)

Applications

- Digital equipment
- Computers and peripherals
- Measuring instruments
- Medical equipment
- Equipment requiring very high impulse attenuation
- Factory automation equipment
- Industrial equipment such as UPS, inverters and converters
- Telecommunications equipment
- Office automation equipment, such as copy and fax machines



Circuit Diagram

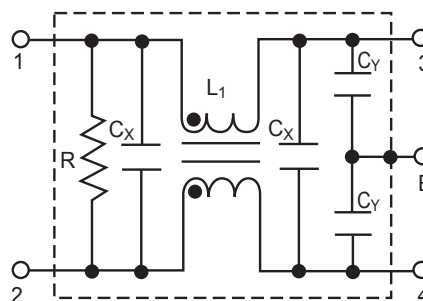

Specifications

| Model* | Rated Voltage (@ 50/60Hz) | Rated Current | Leakage Current (Max.) | Capacitance | | Inductance (L ₁) | Temperature Rise (Max.) |
|-----------------|---------------------------|---------------|------------------------|----------------|----------------|------------------------------|-------------------------|
| | | | | C _Y | C _X | | |
| 62-PMB-050-5-11 | 250VAC | 5A | 0.50mA | 3300pF | 0.1uF | 14mH | 30°C |
| 62-PMF-050-5-11 | | | | | | | |
| 62-PMB-080-5-11 | | 8A | | | .1uF | 7.0mH | |
| 62-PMF-080-5-11 | | | | | | | |
| 62-PMB-100-5-12 | | 10A | | | .22uF | 4.2mH | |
| 62-PMF-100-5-12 | | | | | | | |
| 62-PMB-150-5-13 | | 15A | | | .33uF | 2.2mH | 35°C |
| 62-PMF-150-5-13 | | | | | | | |
| 62-PMB-200-5-13 | | 20A | | | 1.8mH | 45°C** | |
| 62-PMF-200-5-13 | | | | | | | |

Note: Test voltage: 1500VAC one minute, line to ground
Insulation resistance: 300 Mohm min. at 500VDC
Voltage drop: 1V max.
Discharge time: 0.4 sec. max.
Weight: 8.82 ounces (250 grams)

* PMF - designates Fast-on terminals
PMB - designates Bolt-in terminals

** The temperature rise of 20 amp units can be decreased to 30°C by mounting on 200 X 200 x 1.0(mm) steel chassis

Power Line Filters Single Stage

62-PMF & PMB Series

Temperature Characteristics

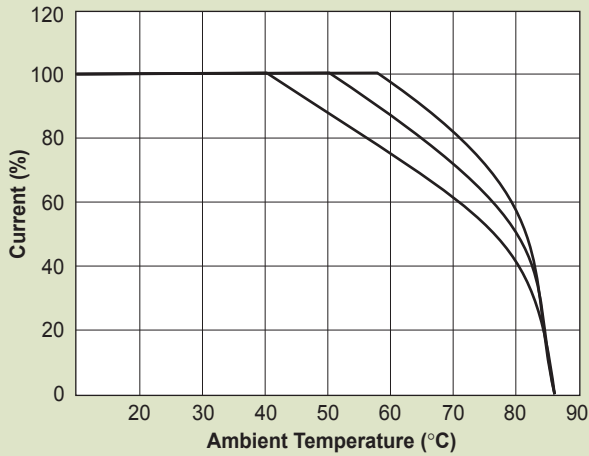

62-PMF

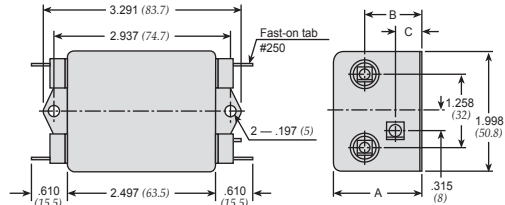

62-PMB

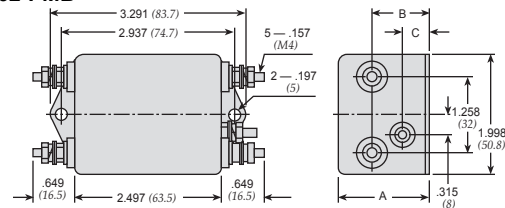

| MODEL | A | B | C |
|--------------------|---------------|--------------|--------------|
| 62-PMF/PMB-100-200 | 1.490 (38) | .944 (24) | .433 (11) |
| 62-PMF/PMB-050-080 | 1.258 (32) | .786 (20) | 0 (0) |

Dimensions in inches (mm)

Common Mode

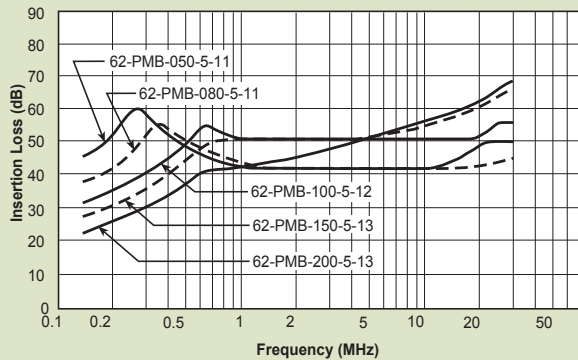
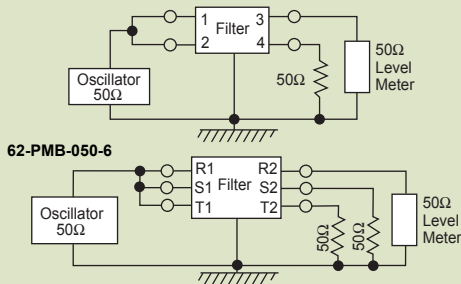

Normal Mode

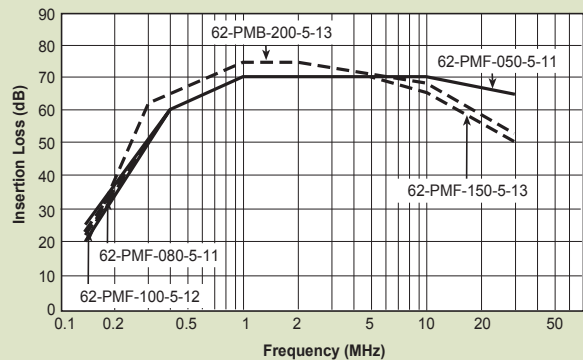
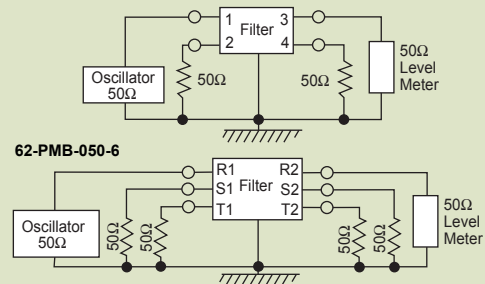

Power Line Filters Single Stage



12-PMF Series



Features

- Space-saving, compact designs
- Suitable for products that must conform to FCC regulations
- Excellent attenuation for high voltage impulse
- Metal case provides effective EMI shielding
- Excellent filtering characteristics for both normal mode and common mode
- Epoxy molded for internal component reliability
- Structure provides effective shielding for noise generated externally and internally
- Operating temperature: -25°C to +85°C

Applications

- Digital equipment
- Computers and peripherals
- Measuring instruments
- Medical equipment
- Equipment requiring very high impulse attenuation
- Factory automation equipment
- Industrial equipment such as UPS, inverters and converters
- Telecommunications equipment
- Office automation equipment, such as copy and fax machines

Circuit Diagram

Circuit 1

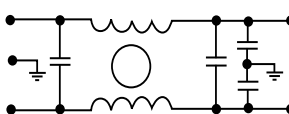

Circuit 2

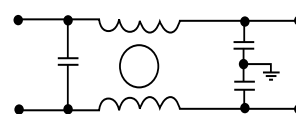

Circuit 3

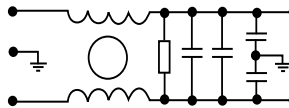

Circuit 4

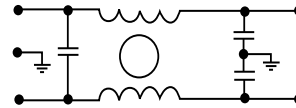

Circuit 5

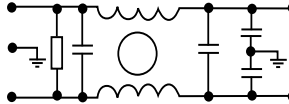

Circuit 6

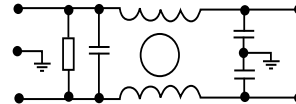

Specifications

| Model | Rated Voltage (@ 50/60Hz) | Rated Current | Leakage Current (Max.) | Circuit Diagram | Figure | Temperature Rise (Max.) |
|----------------|---------------------------|---------------|------------------------|-----------------|--------|-------------------------|
| 12-PMF-001-5-A | 120/250VAC | 1A | 0.5mA | 1 | A | 30°C |
| 12-PMF-002-5-B | | 2A | | 2 | B | |
| 12-PMF-003-5-A | | 3A | | 4 | A | |
| 12-PMF-003-5-B | | 2 | | B | | |
| 12-PMF-006-5-A | | 6A | | 4 | A | |
| 12-PMF-006-5-C | | 1 | | C | | |
| 12-PMF-006-5-D | | 6 | | D | | |
| 12-PMF-010-5-A | | 10A | | 2 | A | |
| 12-PMF-010-5-C | | 3 | | C | | |
| 12-PMF-015-5-C | | 15A | | 5 | E | |
| 12-PMF-015-5-E | | C | | | | |
| 12-PMF-020-5-C | | 20A | | | D | |
| 12-PMF-020-5-D | | D | | | | |
| 12-PMF-020-5-E | | E | | | | |

Note: Test voltage: 1500VAC one minute, line to ground
 Insulation resistance: 300 Mohm min. at 500VDC
 Voltage drop: 1V max.
 Discharge time: 0.4 sec. max.

Power Line Filters Single Stage

12-PMF Series

Figure A

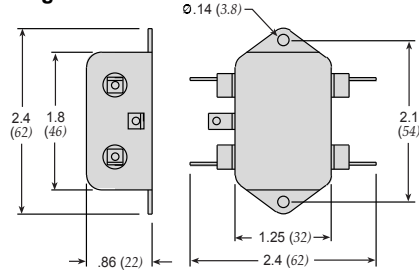

Figure B

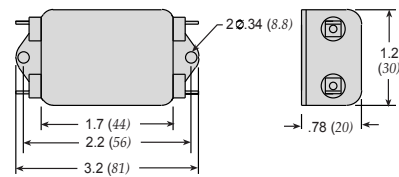

Figure C

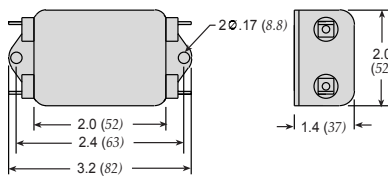

Figure D

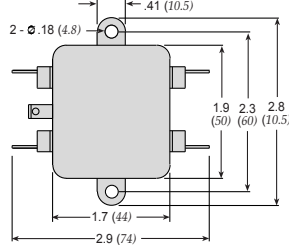
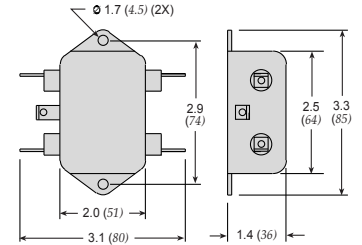
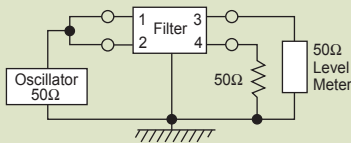

Figure E



Dimensions in inches (mm)

Common Mode



12-PMF-001;-002;-003;-006

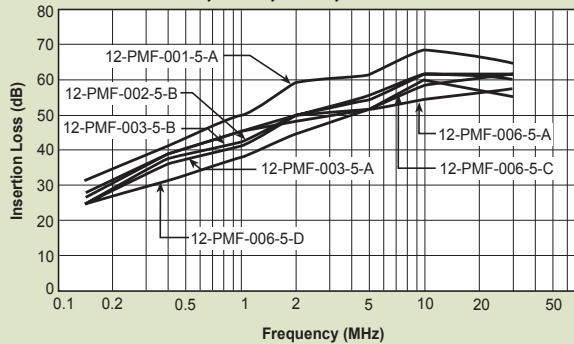

12-PMF-001;-002;-003;-006

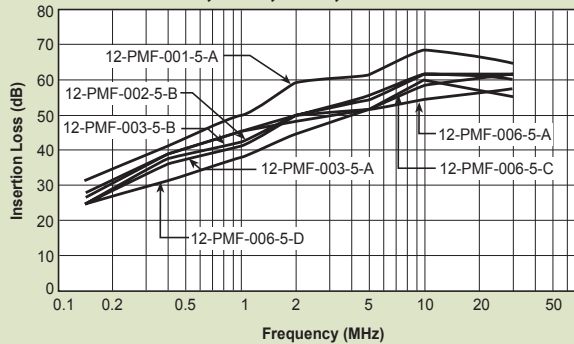

Normal Mode

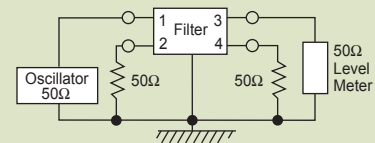

12-PMF-001;-002;-003;-006

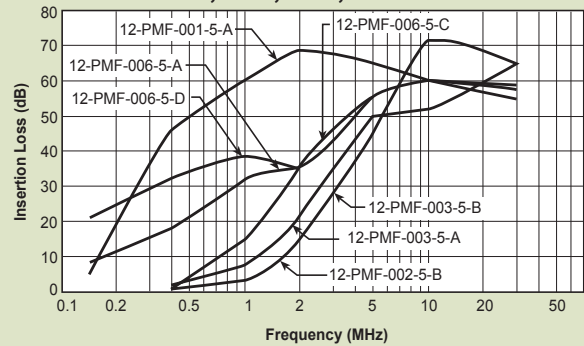

12-PMF-010;-015;-020

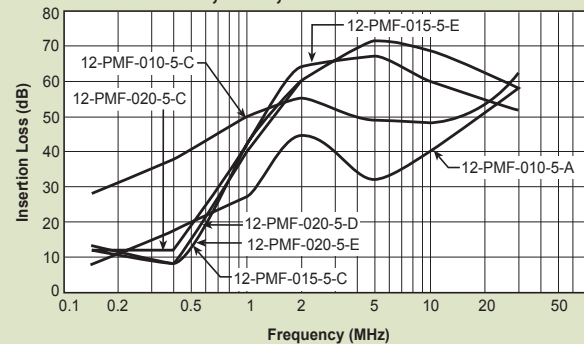

Power Line Filters Single Stage - Higher Current



62-PMB Series

Features

- Space-saving, compact designs
- Suitable for products that must conform to FCC regulations
- Excellent attenuation for high voltage impulse
- Metal case provides effective shielding
- Excellent filtering characteristics for both normal mode and common mode
- Epoxy molded for internal component reliability
- Structure provides effective shielding for noise generated externally and internally
- Safety agency approvals pending
- Designed to be in accordance with VDE 0565 Part 3
- Operating temperature: -25°C to +85°C (including temperature rise)

Applications

- Digital equipment
- Computers and peripherals
- Measuring instruments
- Medical equipment
- Equipment requiring very high impulse attenuation
- Factory automation equipment
- Industrial equipment such as UPS, inverters and converters
- Telecommunications equipment
- Office automation equipment, such as copy and fax machines

Circuit Diagram

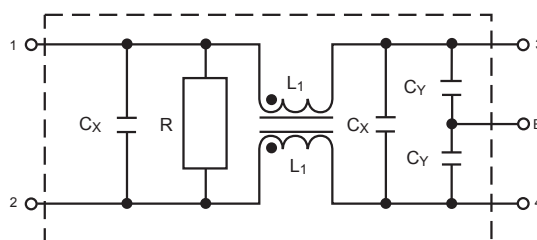

Specifications

| Model | Rated Voltage (@ 50/60Hz) | Rated Current | Leakage Current (Max.) | Capacitance | | Inductance (L ₁) | Temperature Rise (Max.) |
|-----------------|---------------------------|---------------|------------------------|----------------|----------------|------------------------------|-------------------------|
| | | | | C _Y | C _X | | |
| 62-PMB-300-5-14 | 250VAC | 30A | 0.50mA | 3300pF | .47uF | 1.6mH | 45°C |
| 62-PMB-400-5-14 | | 40A | | | | 0.8mH | |

Note: Test voltage: 1500VAC one minute, line to earth
 Insulation resistance: 300 Mohm min. at 500VDC
 Voltage drop: 1V max.
 Discharge time: 0.4 sec. max.
 Weight: 8.82 ounces (250 grams)

Power Line Filters Single Stage - Higher Current

62-PMB Series

62-PMB-300-5-14 and 62-PMB-400-5-14

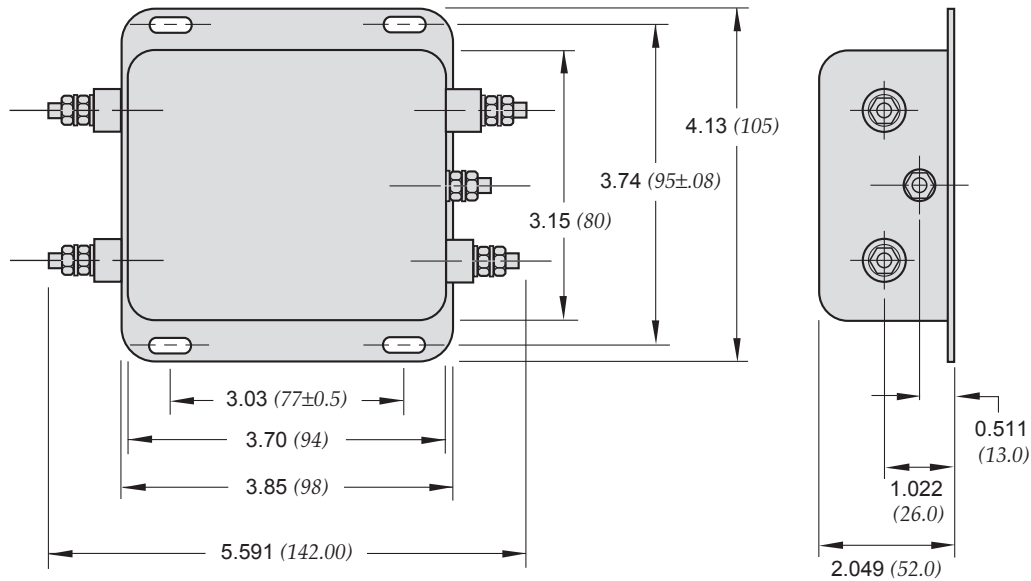

Dimensions in inches (mm)

Normal Mode

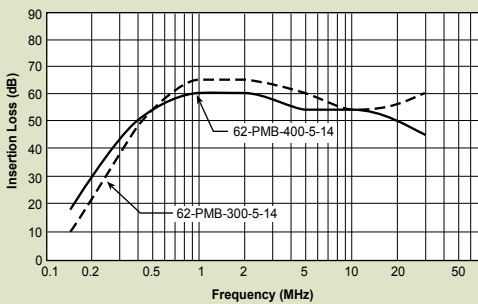
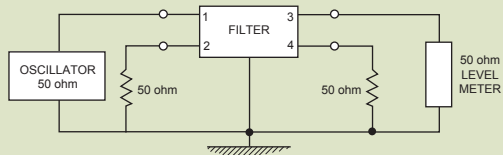

Common Mode

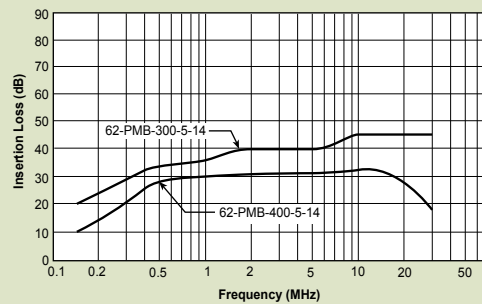
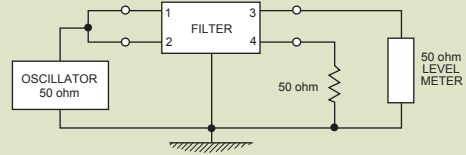

Power Line Filters Single Stage - Higher Current



12-PMB Series

Features

- Space-saving, compact designs
- Suitable for products that must conform to FCC regulations
- Excellent attenuation for high voltage impulse
- Metal case provides effective shielding
- Excellent filtering characteristics for both normal mode and common mode
- Epoxy molded for internal component reliability
- Structure provides effective shielding for noise generated externally and internally
- Designed to be in accordance with VDE 0565 Part 3
- Operating temperature: -25°C to +85°C

Applications

- Digital equipment
- Computers and peripherals
- Measuring instruments
- Medical equipment
- Equipment requiring very high impulse attenuation
- Factory automation equipment
- Industrial equipment such as UPS, inverters and converters
- Telecommunications equipment
- Office automation equipment, such as copy and fax machines

Circuit Diagram

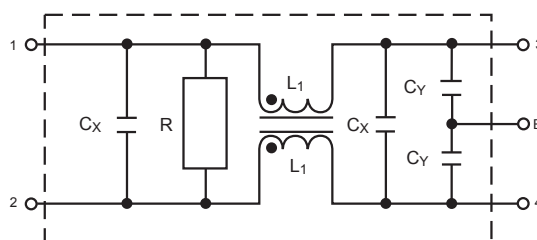

Specifications

| Model | Rated Voltage (@ 50/60Hz) | Rated Current | Leakage Current (Max.) | Circuit Diagram | Figure | Temperature Rise (Max.) |
|----------------|---------------------------|---------------|------------------------|-----------------|--------|-------------------------|
| 12-PMB-025-5-A | 120/250VAC | 25A | 0.5mA | 1 | A | 30°C |
| 12-PMB-030-5-A | | 30A | | | | |
| 12-PMB-035-5-B | | 35A | | | | |
| 12-PMB-050-5-B | | 50A | 1.0mA | | | |
| 12-PMB-100-8-C | | 100A | | | | |
| 12-PMB-120-8-C | | 120A | | | | |

Note: Test voltage: 1500VAC one minute, line to earth
 Insulation resistance: 300 Mohm min. at 500VDC
 Voltage drop: 1V max.
 Discharge time: 0.4 sec. max.
 Weight: 8.82 ounces (250 grams)

Power Line Filters Single Stage - Higher Current

12-PMB Series

Figure A

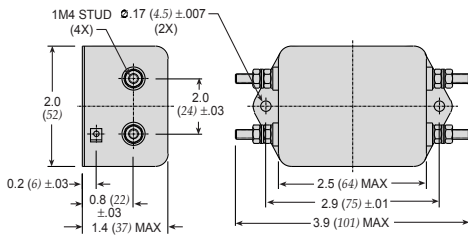

Figure B

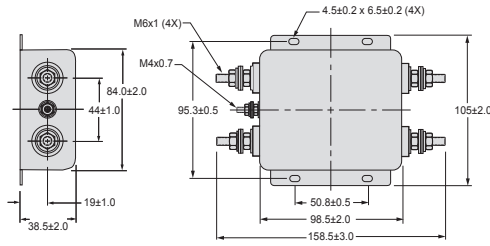
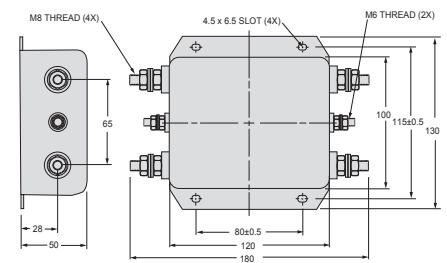
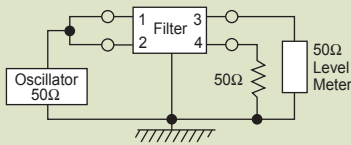

Figure C



Dimensions in inches (mm)

Common Mode



12-PMB-025;-030;-035

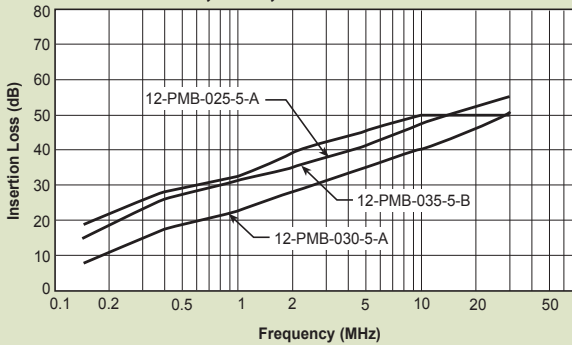

12-PMB-050;-100;-120

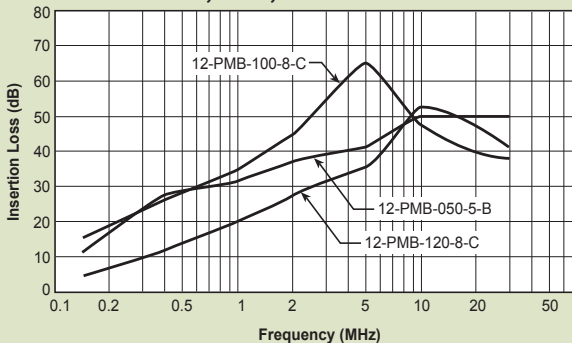

Normal Mode

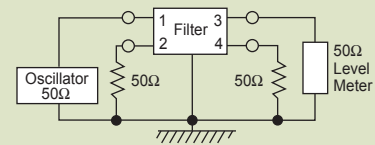

12-PMB-025;-030;-035

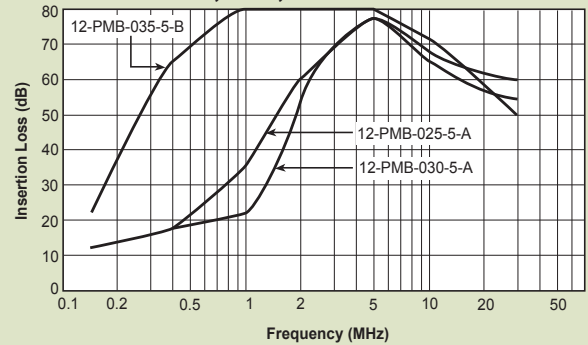

12-PMB-050;-100;-120

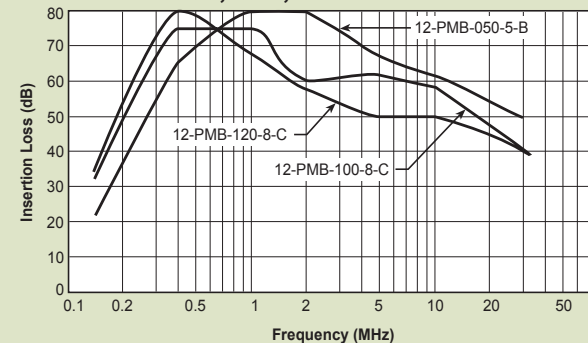

Power Line Filters DC - Higher Current



12-PMF & 12 PMB DC Series

Features

- Space-saving, compact designs
- Suitable for products that must conform to FCC regulations
- Excellent attenuation for high voltage impulse
- Metal case provides effective shielding
- Excellent filtering characteristics for both normal mode and common mode
- Epoxy molded for internal component reliability
- Structure provides effective shielding for noise generated externally and internally
- Designed to be in accordance with VDE 0565 Part 3
- Operating temperature: -40°C to +85°C

Applications

- Digital equipment
- Computers and peripherals
- Measuring instruments
- Equipment requiring very high impulse attenuation
- Factory automation equipment
- Industrial equipment such as UPS, inverters and converters
- Telecommunications equipment

Circuit Diagram

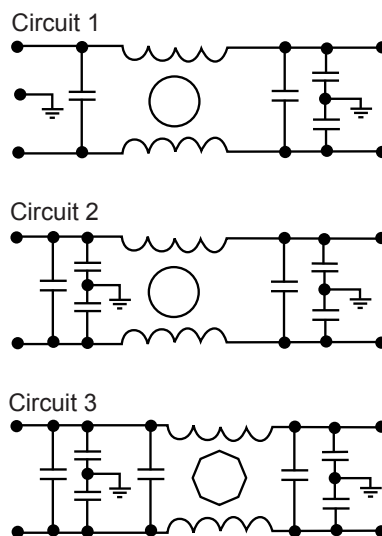

Specifications

| Model | Rated Voltage (@ 50/60Hz) | Rated Current | Circuit Diagram | Figure | Temperature Rise (Max.) |
|-----------------|---------------------------|---------------|-----------------|--------|-------------------------|
| 12-PMF-006-DC-C | 48/250 VDC | 6A | 1 | A | 30°C |
| 12-PMF-010-DC-C | | 10A | | | |
| 12-PMF-015-DC-C | | 15A | | | |
| 12-PMF-020-DC-C | | 20A | | | |
| 12-PMF-025-DC-D | | 25A | | | |
| 12-PMB-025-DC-F | | | | | |
| 12-PMB-030-DC-F | | 30A | | C | |
| 12-PMB-035-DC-F | | 35A | | | |
| 12-PMB-040-DC-F | | 40A | | | |
| 12-PMB-040-DC-B | | 50A | | D | |
| 12-PMB-050-DC-B | | | | | |
| 12-PMB-060-DC-B | | 60A | E | | |
| 12-PMB-080-DC-G | | 80A | | | |
| 12-PMB-080-DC-C | | 100A | 3 | F | |
| 12-PMB-100-DC-C | | | | | |
| 12-PMB-120-DC-C | | | | | |
| 12-PMB-140-DC-C | | 140A | 2 | G | |
| 12-PMB-180-DC-E | | 180A | | | |
| 12-PMB-200-DC-E | | 200A | | | |
| 12-PMB-260-DC-E | | 260A | | | |

Note: Test voltage: 1500VAC one minute, line to earth
Insulation resistance: 300 Mohm min. at 500VDC
Voltage drop: 1V max.

Discharge time: 0.4 sec. max.
Weight: 8.82 ounces (250 grams)

Power Line Filters DC - Higher Current

12-PMF & 12-PMB DC Series

Figure B

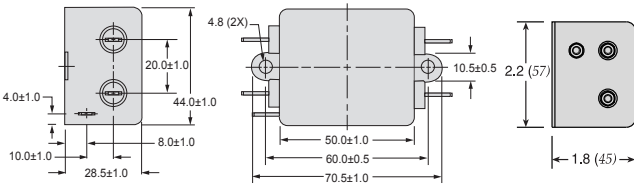

Figure C



Figure A

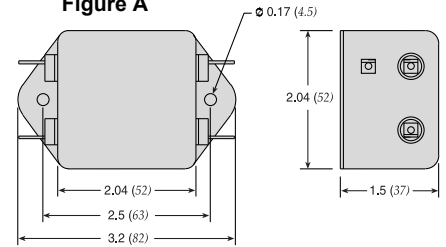

Figure D



Figure E

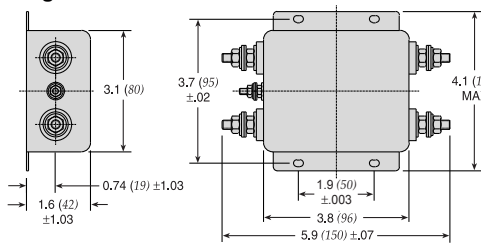

Figure F

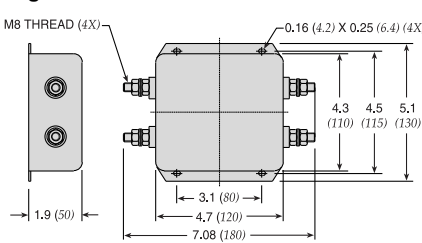
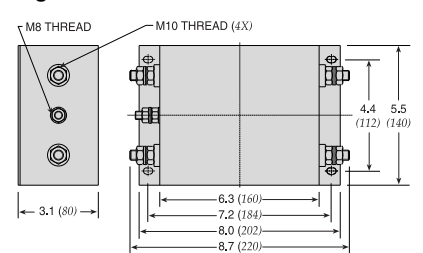
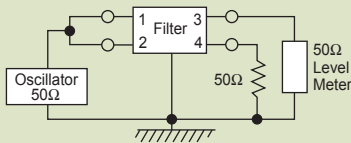

Figure G



Dimensions in inches (mm)

Common Mode



12-PMF-006;-010;-015;-020;-025

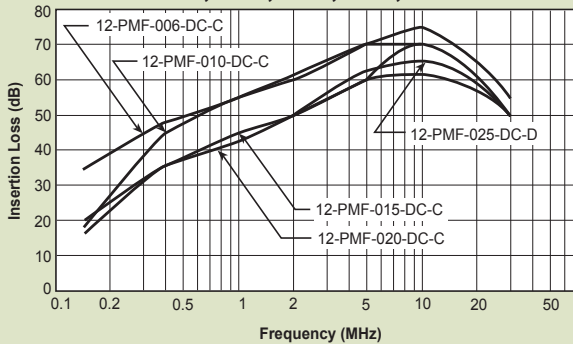

12-PMB-025; thru -260

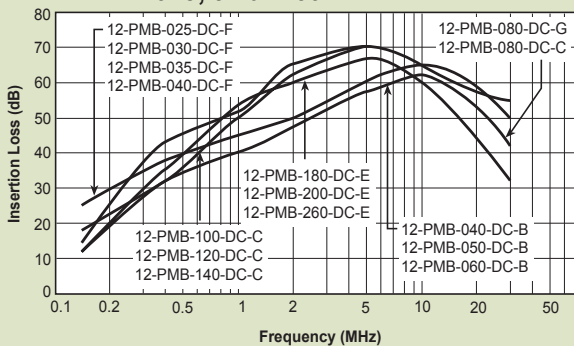

Normal Mode

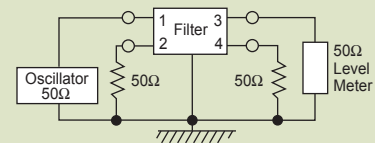

12-PMF-006;-010;-015;-020;-025

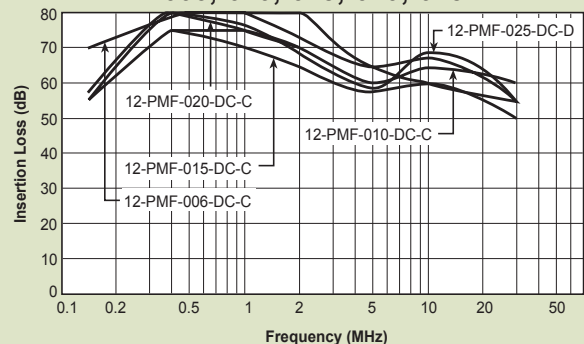

12-PMB-025; thru -260

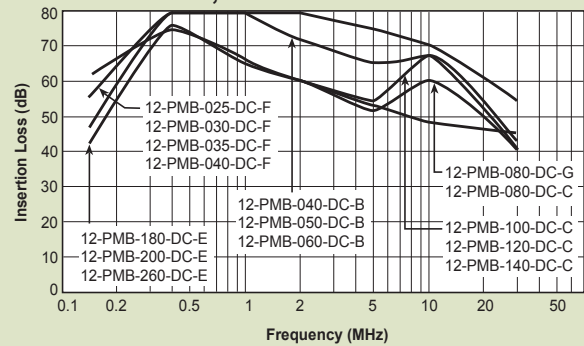

Power Line Filters Dual Stage



62-MMF Series

Features

- Suitable for products that must conform to FCC regulations
- Excellent attenuation for high voltage impulse
- Metal case provides effective EMI shielding
- Two stages for excellent filtering characteristics
- Epoxy molded for reliability
- Structure provides effective shielding for noise generated both externally and internally
- Operating temperature: -25°C to +85°C (including temperature rise, see graph on page PF73)

Applications

- Digital equipment
- Personal computers and peripherals
- Measuring instruments and medical equipment
- Telecommunications equipment
- Equipment requiring very high noise attenuation

Circuit Diagram

62-MMF-XXX-7-11

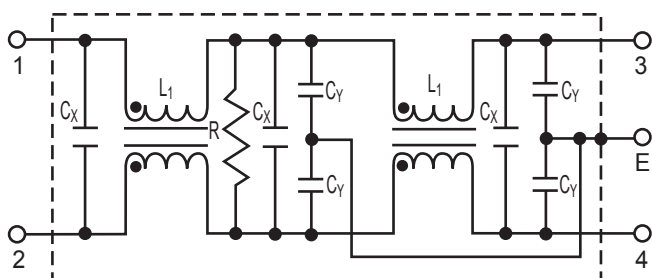

Specifications

| Model | Rated Voltage (@ 50/60Hz) | Rated Current | Leakage Current (Max.) | Capacitance | | | Inductance (L ₁) (2X) | Temperature Rise (Max.) |
|-----------------|------------------------------|---------------|---------------------------|-----------------|-----------------|----------------|--------------------------------------|----------------------------|
| | | | | C _{Y1} | C _{Y2} | C _X | | |
| 62-MMF-030-7-11 | 250VAC | 3A | .7mA | 3300pF | 1000pF | 0.1uF | 3.7mH | 30°C |
| 62-MMF-050-7-11 | 250VAC | 5A | .7mA | 3300pF | 1000pF | 0.1uF | 2.9mH | 30°C |

Note: All types are designed to meet the requirement of UL 1283, CSA 22.2, VDE 0565-3

Test voltage: 1500VAC one minute, line to ground

Insulation resistance: 300 Mohm min. at 500VDC

Leakage current: 0.7 mA max.

Voltage drop: 1V max.

Discharge time: 0.4 sec. max.

Weight: 6.0 ounces (170 grams)

Power Line Filters Dual Stage

62-MMF Series

Temperature Characteristics

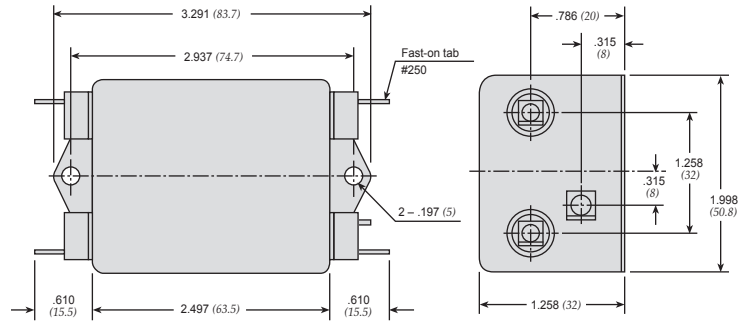
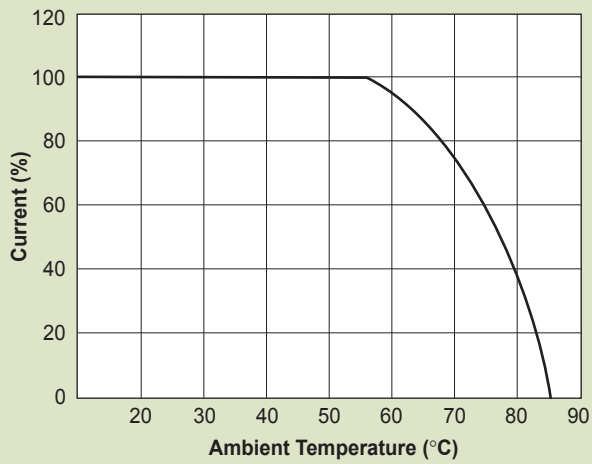

Common Mode

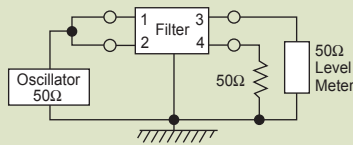

62-MMF

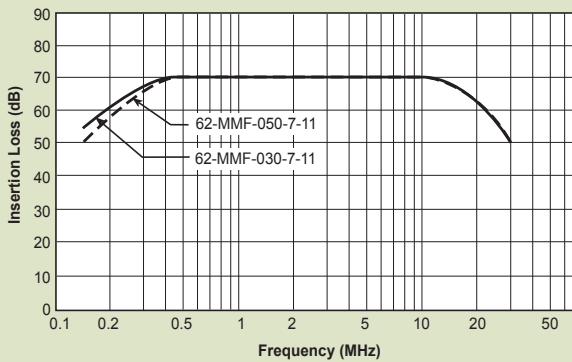

Normal Mode

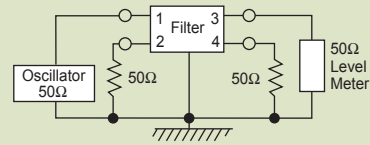

62-MMF

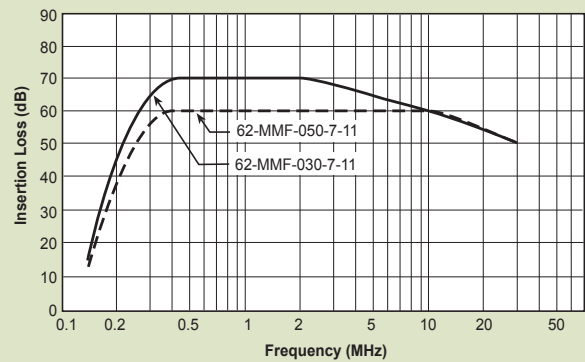

Power Line Filters Dual Stage



12-MMF & 12-MMB Series

Features

- Suitable for products that must conform to FCC regulations
- Excellent attenuation for high voltage impulse
- Metal case provides effective EMI shielding
- Two stages for excellent filtering characteristics
- Structure provides effective shielding for noise generated both externally and internally
- Operating temperature: -40°C to +85°C
- High performance
- Low leakage current

Applications

- Digital equipment
- Switching power supplies
- Personal computers and peripherals
- Measuring instruments and medical equipment
- Telecommunications equipment
- Equipment requiring very high noise attenuation

Circuit Diagram

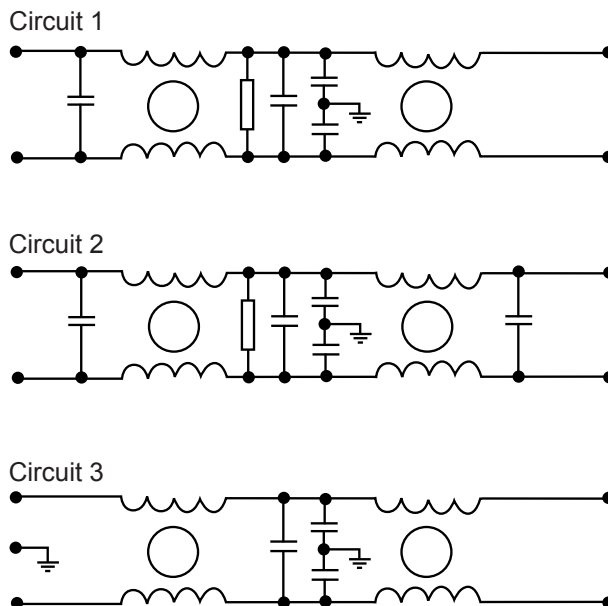

Specifications

| Model | Rated Voltage (@ 50/60Hz) | Rated Current | Leakage Current (Max.) | Circuit Diagram | Figure | Temperature Rise (Max.) |
|----------------|---------------------------|---------------|--------------------------------|-----------------|--------|-------------------------|
| 12-MMF-002-5-F | 120/250VAC | 2A | 0.25mA@120VAC/ 0.5mA@250VAC | 1 | A | 30°C |
| 12-MMF-003-5-F | | 3A | | | A | |
| 12-MMF-003-5-A | | | | | B | |
| 12-MMF-006-5-F | | 6A | | A | | |
| 12-MMF-006-5-G | | | | C | | |
| 12-MMF-008-5-B | | 8A | | | | |
| 12-MMF-010-5-F | | 10A | | A | | |
| 12-MMF-010-5-G | | | | A1 | | |
| 12-MMF-010-5-B | | | | C | | |
| 12-MMF-012-5-B | | | | 12A | | |
| 12-MMB-015-5-E | | | | 15A | D | |
| 12-MMB-020-5-F | | | | 20A | G | |
| 12-MMB-030-5-D | | | | 30A | E | |
| 12-MMB-050-5-C | | | | 50A | F | |

Note: All types are designed to meet the requirement of UL 1283, CSA 22.2, VDE 0565-3
 Test voltage: 1500VAC one minute, line to ground
 Insulation resistance: 300 Mohm min. at 500VDC
 Voltage drop: 1V max.
 Discharge time: 0.4 sec. max.

Power Line Filters Dual Stage

12-MMF & 12-MMB Series

Figure B

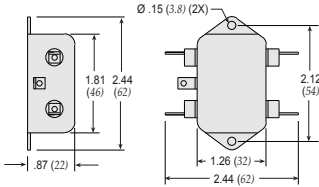

Figure C

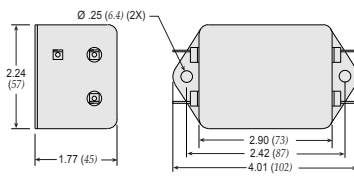

Figure E

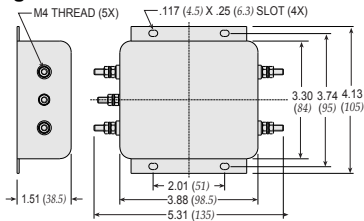

Figure F

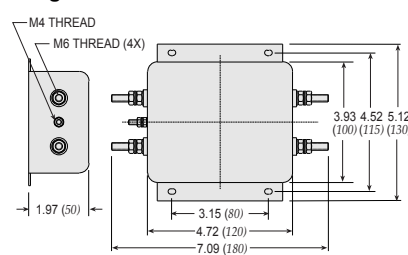

Figure A

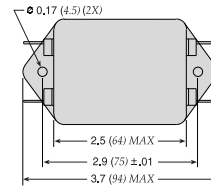

Figure A1

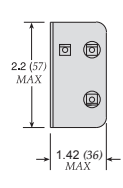

Figure D

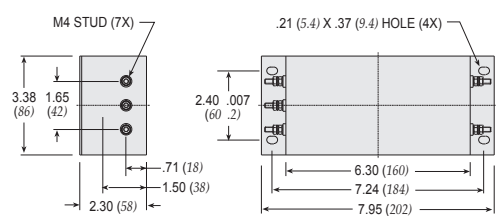
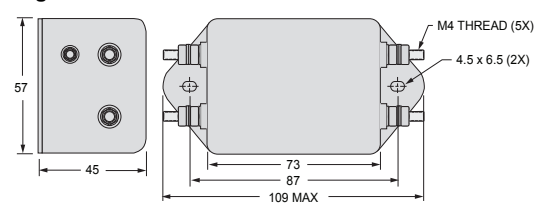
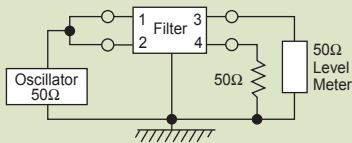

Figure G



Dimensions in inches (mm)

Common Mode



12-MMF-002;-003;-006;-008

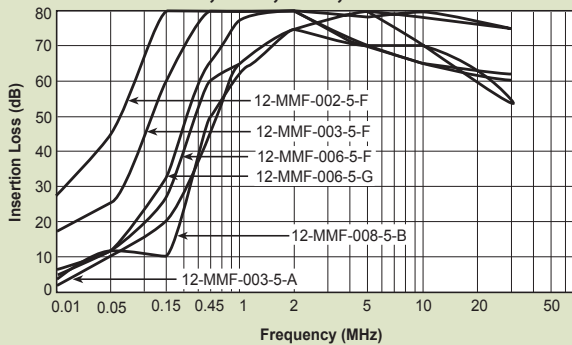

12-MMF-010;-012;-015;-020;-030;-050

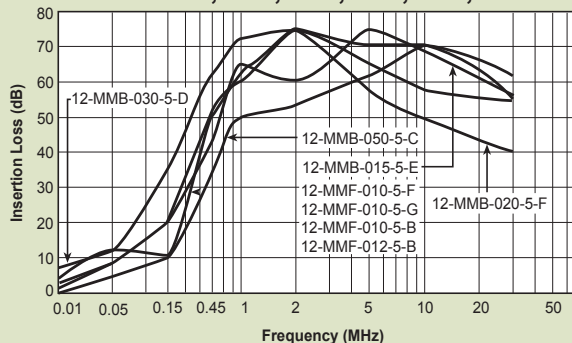

Normal Mode

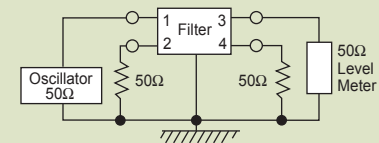

12-MMF-002;-003;-006;-008

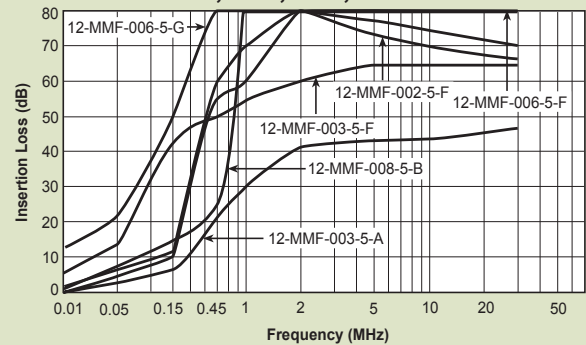

12-MMF-010;-012;-015;-020;-030;-050

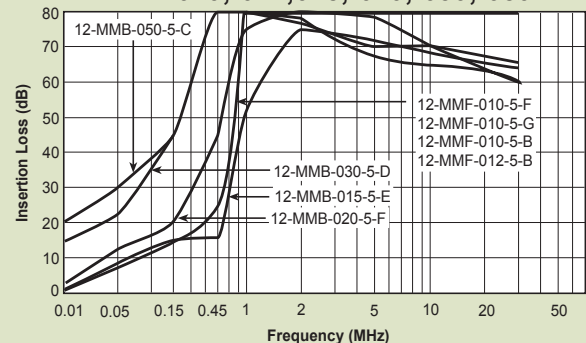

Power Line Filters Dual Stage



12-MMF & 12-MMB Series

Features

- Suitable for products that must conform to FCC regulations
- Excellent attenuation for high voltage impulse
- Metal case provides effective EMI shielding
- Two stages for excellent filtering characteristics
- Structure provides effective shielding for noise generated both externally and internally
- Operating temperature: -40°C to +85°C
- High performance

Applications

- Digital equipment
- Personal computers and peripherals
- Measuring instruments and medical equipment
- Telecommunications equipment
- Equipment requiring very high noise attenuation

Circuit Diagram

Circuit 1

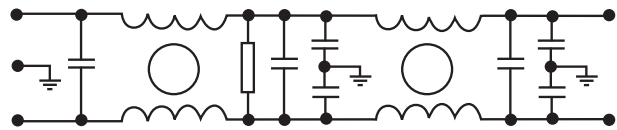

Circuit 2

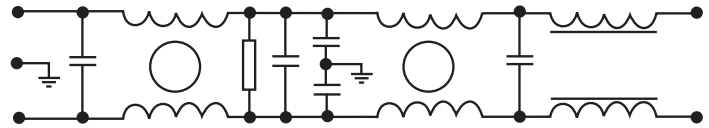

Specifications

| Model | Rated Voltage (@ 50/60Hz) | Rated Current | Leakage Current (Max.) | Circuit Diagram | Figure | Temperature Rise (Max.) |
|-----------------|---------------------------|---------------|------------------------|-----------------|--------|-------------------------|
| 12-MMF-003-11-F | 120/250VAC | 3A | 1.5mA | 1 | A | 30°C |
| 12-MMF-006-11-F | | 6A | | | C | |
| 12-MMF-010-11-F | | 10A | | | B | |
| 12-MMB-015-11-G | | 15A | | 2 | D | |
| 12-MMB-020-11-D | | 20A | | | E | |
| 12-MMB-030-11-D | | 30A | | | F | |
| 12-MMB-040-11-B | | 40A | | 1 | | |
| 12-MMB-040-11-E | | | | | | |
| 12-MMB-050-11-H | | 50A | | | | |

Note: All types are designed to meet the requirement of UL 1283, CSA 22.2. VDE 0565-3
 Test voltage: 1500VAC one minute, line to ground
 Insulation resistance: 300 Mohm min. at 500VDC
 Leakage current: 0.7 mA max.
 Voltage drop: 1V max.
 Discharge time: 0.4 sec. max.
 Weight: 6.0 ounces (170 grams)

Power Line Filters Dual Stage

12-MMF & 12-MMB Series

Figure A

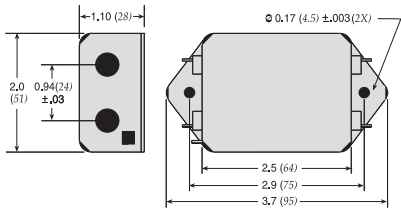

Figure B

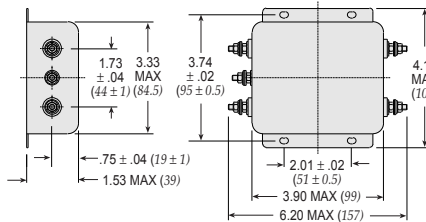

Figure C

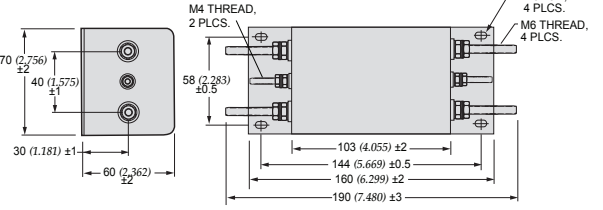

Figure D

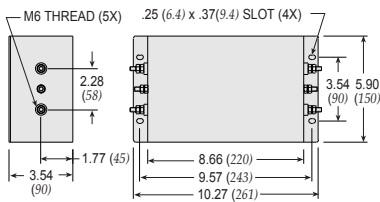

Figure E

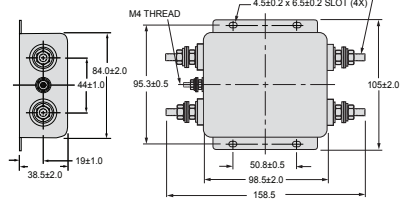
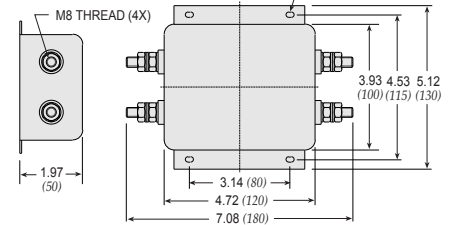
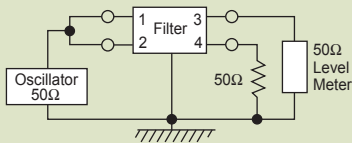

Figure F



Dimensions in inches (mm)

Common Mode



12-MMF-003;-006;-010;-012;-015

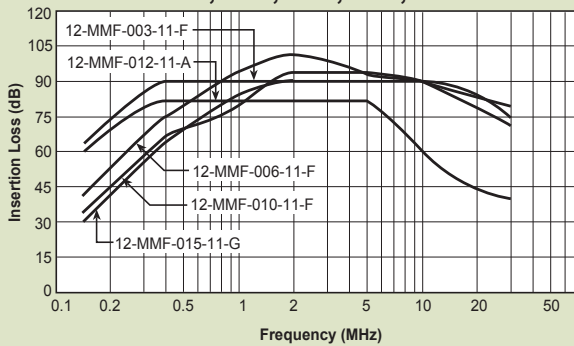

12-MMF-020;-030;-040;-050

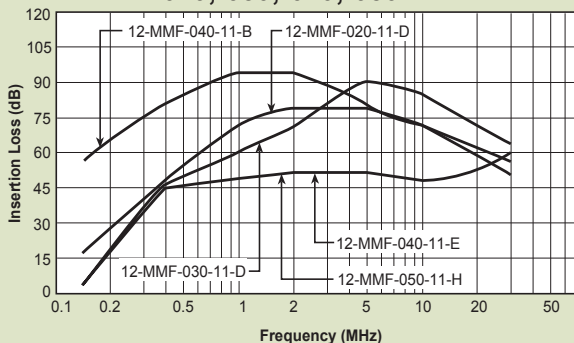

Normal Mode

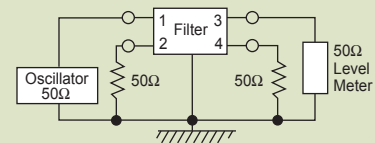

12-MMF-003;-006;-010;-012;-015

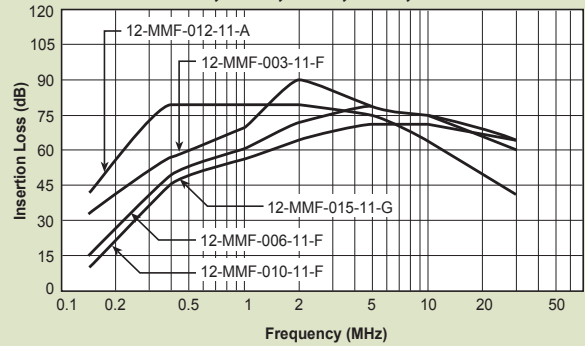

12-MMF-020;-030;-040;-050

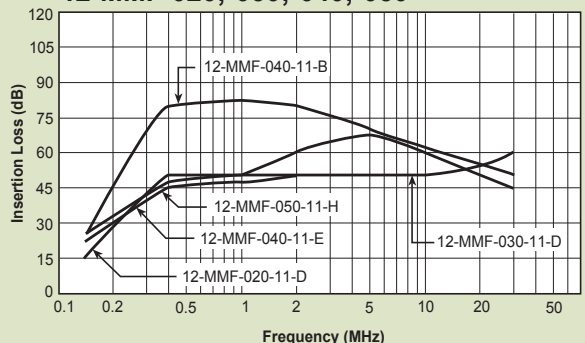

Power Line Filters Dual Stage



12-MMF & 12-MMB Series

Features

- Suitable for products that must conform to FCC regulations
- Excellent attenuation for high voltage impulse
- Metal case provides effective EMI shielding
- Two stages for excellent filtering characteristics
- Epoxy molded for reliability
- Structure provides effective shielding for noise generated both externally and internally
- Operating temperature: -25°C to +85°C

Applications

- Digital equipment
- Personal computers and peripherals
- Measuring instruments and medical equipment
- Telecommunications equipment
- Equipment requiring very high noise attenuation

Circuit Diagram

Circuit 1

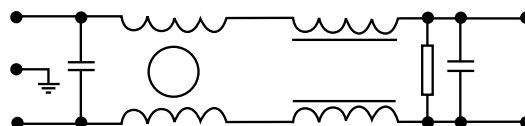

Circuit 2

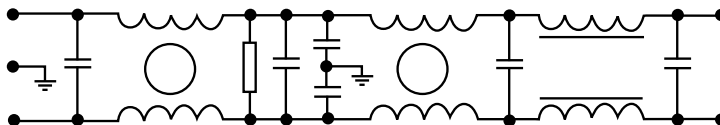

Circuit 3

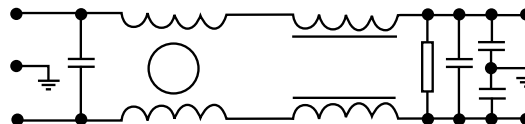

Specifications

| Model | Rated Voltage (@ 50/60Hz) | Rated Current | Leakage Current (Max.) | Circuit Diagram | Figure | Temperature Rise (Max.) | |
|----------------|---------------------------|---------------|------------------------|-----------------|--------|-------------------------|---|
| 12-MMF-001-5-F | 120/250VAC | 1A | 0.5mA | 3 | A | 30°C | |
| 12-MMF-003-5-G | | 3A | | | 5uA | | 1 |
| 12-MMF-003-2-G | | | 6A | | | | |
| 12-MMF-006-5-G | | 10A | 0.5mA | 2 | D | | |
| 12-MMB-010-5-D | | 15A | | | | | |
| 12-MMB-015-5-E | | 20A | | | | | |
| 12-MMB-020-5-E | | 30A | | | | | |
| 12-MMB-030-5-E | | | | | | | |

Note: All types are designed to meet the requirement of UL 1283, CSA 22.2. VDE 0565-3
 Test voltage: 1500VAC one minute, line to ground
 Insulation resistance: 300 Mohm min. at 500VDC
 Leakage current: 0.7 mA max.
 Voltage drop: 1V max.
 Discharge time: 0.4 sec. max.
 Weight: 6.0 ounces (170 grams)

Power Line Filters Dual Stage

12-MMF & 12-MMB Series

Figure A

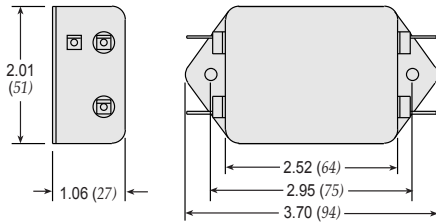

Figure B

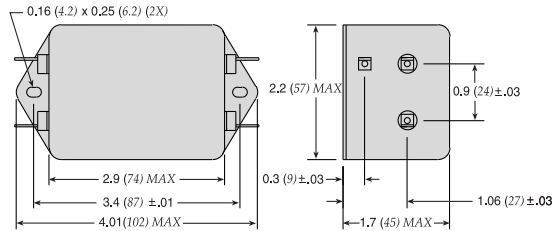

Figure C

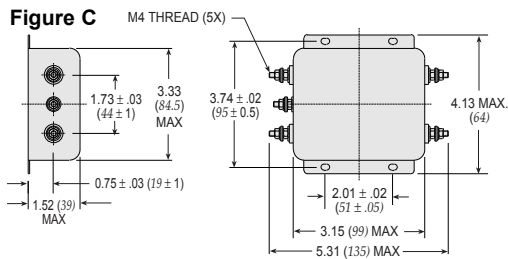
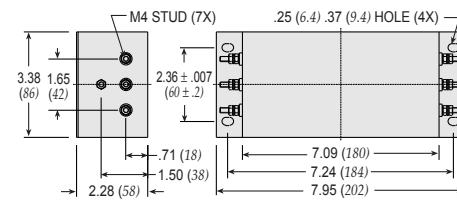
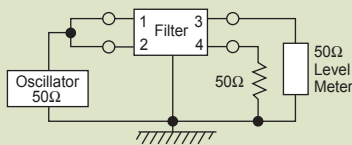

Figure D



Dimensions in inches (mm)

Common Mode



12-MMF-001;-003;-006

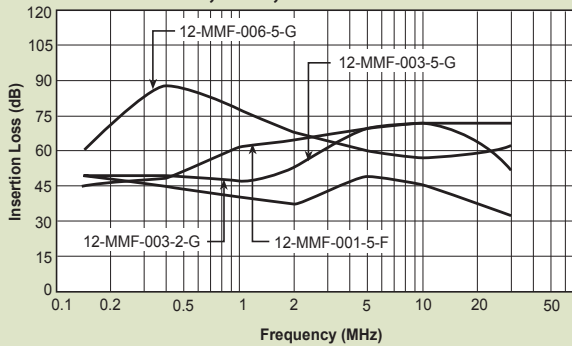

12-MMB-010;-015;-020;-030

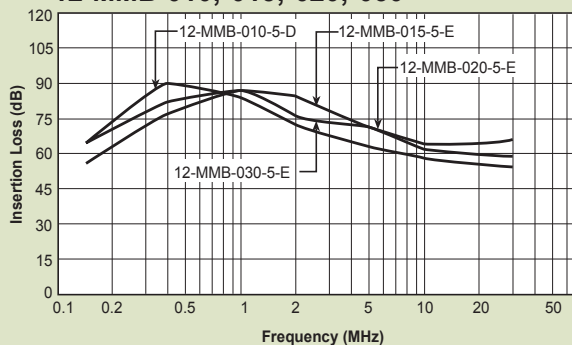

Normal Mode

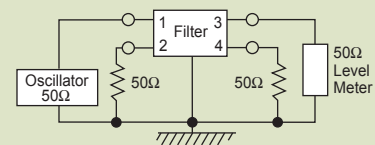

12-MMF-001;-003;-006

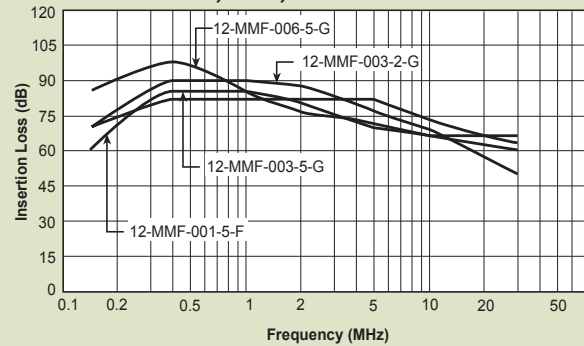

12-MMB-010;-015;-020;-030

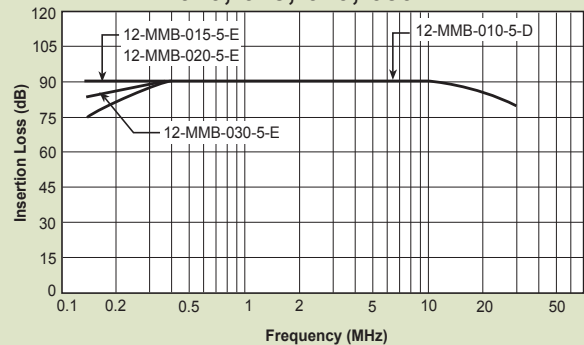

Power Line Filters Three Phase

Low Current/High Performance



62-PMB/63-PMF Series

Features

- Excellent attenuation for high voltage impulse
- Effective for both balanced and unbalanced three-phase loads
- Metal case provides effective EMI shielding
- Epoxy molded for internal component reliability
- Compact and economical
- Excellent filtering characteristics for both normal and common mode
- Various current ratings available: 3, 5, 8 and 16 Amps
- Safety agency approvals pending
- Operating temperature: -25°C to +85°C (including temperature rise, see graph on page PF81)

Applications

- Digital equipment
- Industrial equipment (UPS, inverters and converters)
- Automation equipment
- Computerized washing machines

Circuit Diagram

62-PMB-050-6-12 (5 Amp Delta)

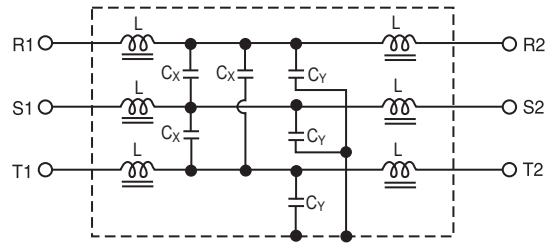

63-PMF-030-8-14 and 63-PMF-080-8-14 (3 and 8 Amp Wye)

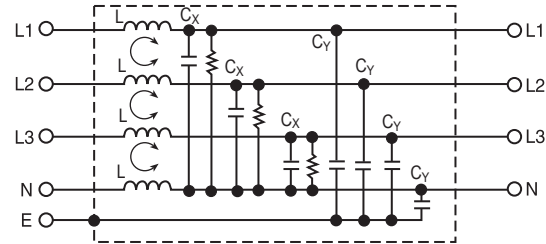

63-PMF-160-9-21 (16 Amp Wye)

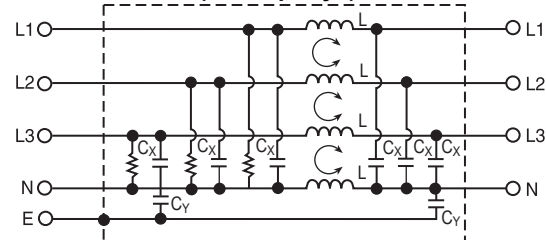

Specifications

| Model | Rated Voltage (@ 50/60Hz) | Rated Current | Leakage Current (Max.) | Capacitance | | Inductance (L ₁) | Temperature Rise (Max.) |
|-----------------|---------------------------|---------------|------------------------|----------------|----------------|------------------------------|-------------------------|
| | | | | C _Y | C _X | | |
| 62-PMB-050-6-12 | 250VAC | 5A | 0.6mA | 2200pF | 0.22uF | 115mH | 45°C |
| 63-PMF-030-8-14 | 480VAC | 3A | 1.0mA | 4700pF (4X) | 470uF (3X) | 1.0mH (4X) | 30°C |
| 63-PMF-080-8-14 | | 8A | | | | 0.74mH (4X) | 40°C |
| 63-PMF-160-9-21 | | 16A | 3.0mA | 0.015uF (2X) | 1.0uF (6X) | 1.2mH (4X) | 45°C |

Note: Test Voltage 1500VAC one minute, line to ground.
 Insulation Resistance: 300 MΩ min. at 500VDC.
 Voltage Drop: 1V max. at rated current.
 Weight: 8.82 ounces (250 grams) for 63-PMF-030-8-14 and 63-PMF-080-8-14
 19.4 ounces (550 grams) for 62-PMB-050-6-12
 51.5 ounces (1450 grams) for 63-PMF-160-9-21

Power Line Filters Three Phase

Low Current/High Performance

62-PMB/63-PMF Series

62-PMB-050-6-12 (5 Amp)

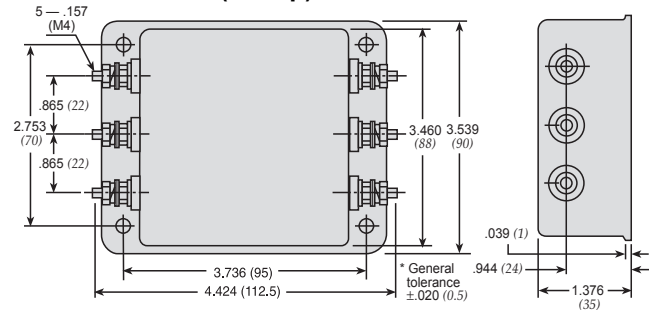

63-PMF-030-8-14 and 63-PMF-080-8-14 (3 and 8 Amp)

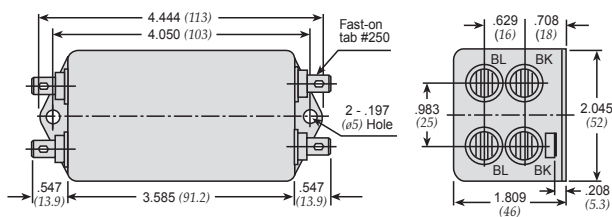

Dimensions in inches (mm)

63-PMF-160-9-21 (16 Amp)

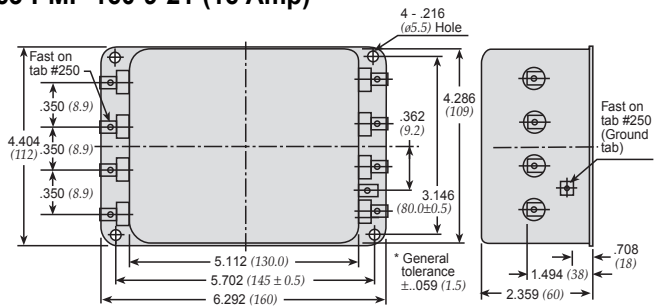

Normal Mode

62-PMB-050-6-12 (5 Amp)

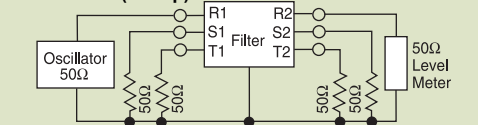

63-PMF (3, 8 and 16 Amp)

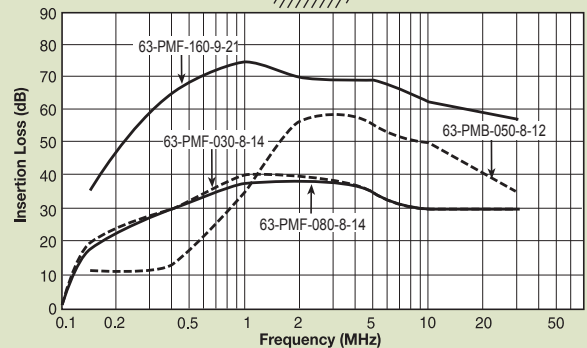
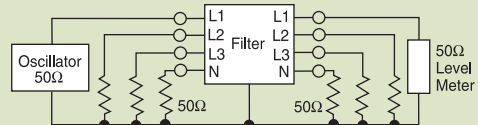

Common Mode

62-PMB-050-6-12 (5 Amp)

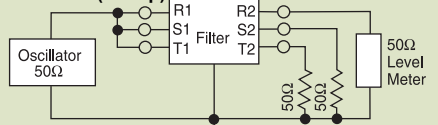

63-PMF (3, 8 and 16 Amp)

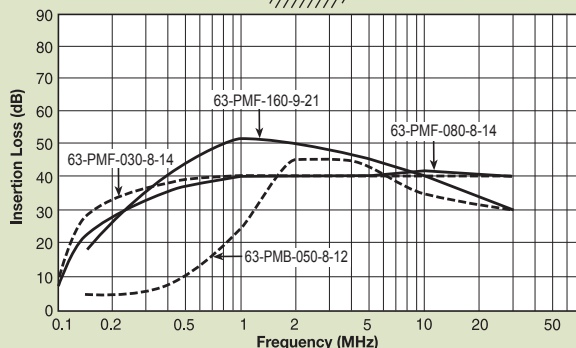
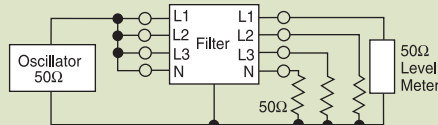

Power Line Filters Three Phase



13-PWF/PWL/PWB Series

Features

- Excellent attenuation for high voltage impulse
- Effective for both balanced and unbalanced three-phase loads
- Metal case provides effective EMI shielding
- Epoxy molded for internal component reliability
- Suitable for both Wye and Delta connection
- Excellent filtering characteristics for both normal and common mode
- Operating temperature: -40°C to +85°C
- Designed for 3-phase 4-line power supply systems

Applications

- Digital equipment
- Industrial equipment (UPS, inverters and converters)
- Automation equipment
- Computerized washing machines

Circuit Diagram

Circuit 1

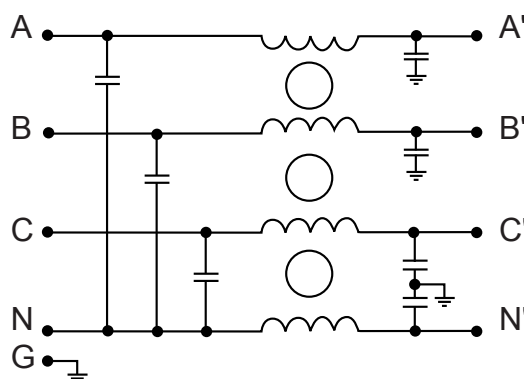

Circuit 2

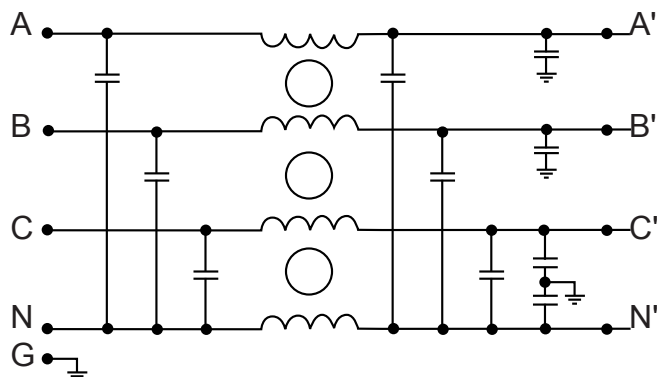

Specifications

| Model | Rated Voltage (@ 50/60Hz) | Rated Current | Leakage Current (Max.) | Circuit Diagram | Figure | Temperature Rise (Max.) | |
|-----------------|---------------------------|---------------|------------------------|-----------------|--------|-------------------------|-----|
| 13-PWF-005-12-H | 440/250VAC | 5A | 1.5mA | 1 | A | 30°C | |
| 13-PWL-005-12-C | | | | | B | | |
| 13-PWF-010-12-H | | | | | A | | |
| 13-PWL-010-12-C | | B | | | | | |
| 13-PWB-010-12-D | | 10A | | 2 | C | | |
| 13-PWB-015-12-D | | | | | | | 15A |
| 13-PWB-020-12-D | | | | | | | 20A |
| 13-PWB-025-12-D | | | | | | | 25A |
| 13-PWB-030-12-D | | | | | | | 30A |

Note: Test Voltage 1500VAC one minute, line to ground.
Insulation Resistance: 300 MΩ min. at 500VDC.
Voltage Drop: 1V max. at rated current.

Power Line Filters Three Phase

13-PWF/PWL/PWB Series

Figure A

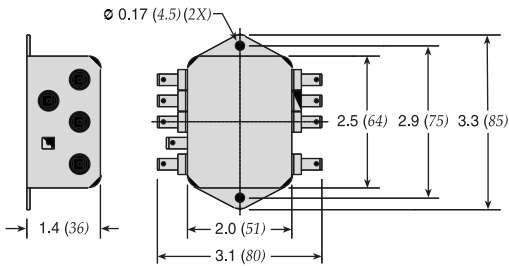

Dimensions in inches (mm)

Figure B

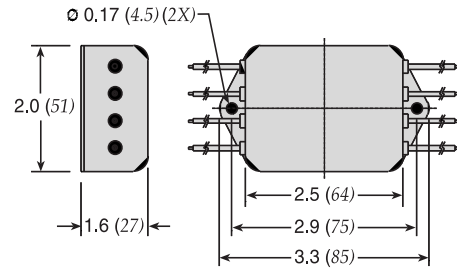
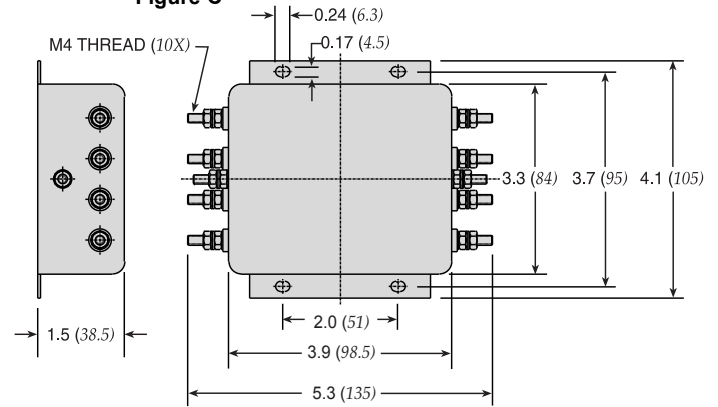
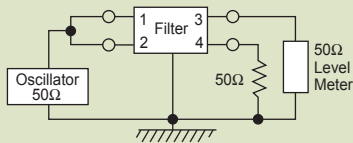

Figure C



Common Mode



13-PWF-005;-010;-PWL-005;-010;-PWB-010

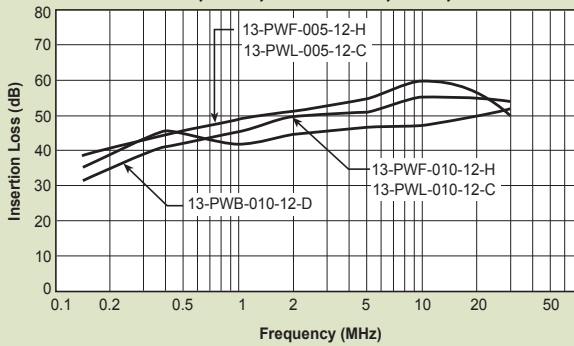

13-PWB-015;-020;-025;-030

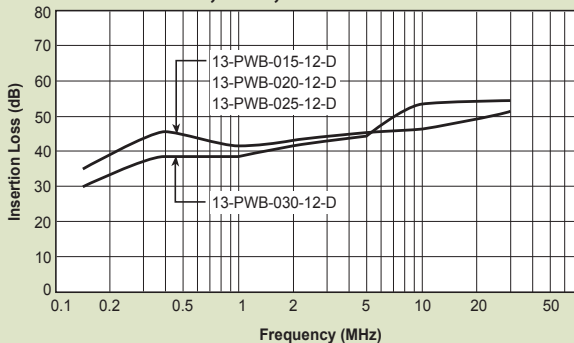

Normal Mode

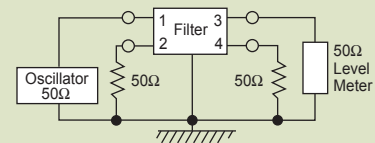

13-PWF-005;-010;-PWL-005;-010;-PWB-010

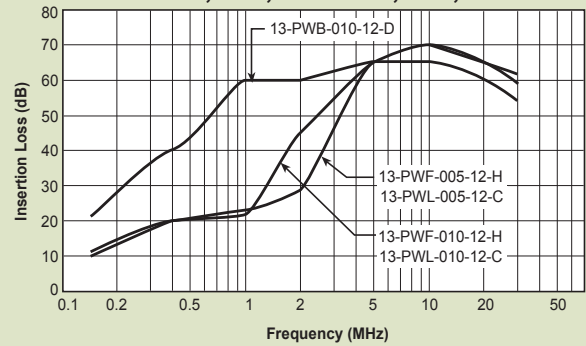

13-PWB-015;-020;-025;-030

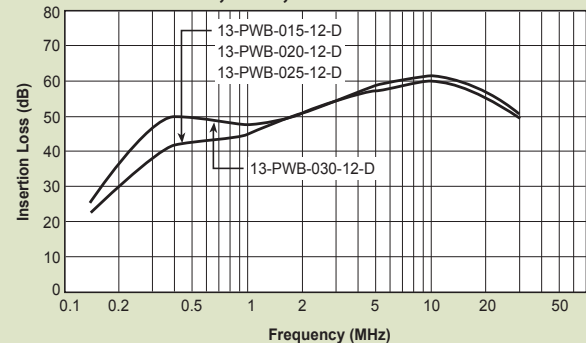

Power Line Filters Three Phase

High Performance

13-PDF/PDL/PDB Series

Features

- Excellent attenuation for high voltage impulse
- Effective for both balanced and unbalanced three-phase loads
- Metal case provides effective EMI shielding
- Epoxy molded for internal component reliability
- Compact and economical
- Excellent filtering characteristics for both normal and common mode
- Operating temperature: -40°C to +85°C
- Designed for 3-phase, 3-Delta connection system

Applications

- Digital equipment
- Industrial equipment (UPS, inverters and converters)
- Automation equipment
- Switching power supplies



Circuit Diagram

Circuit 1

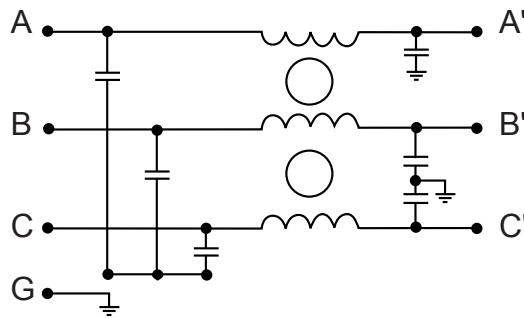

Circuit 2

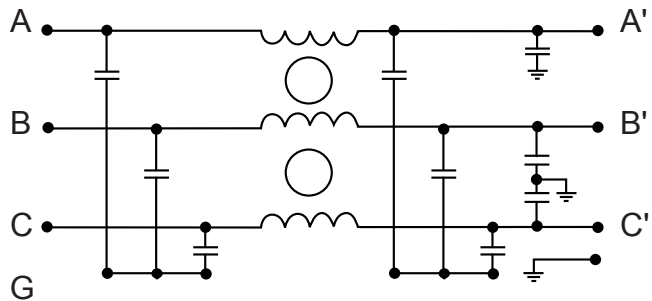

Specifications

| Model | Rated Voltage (@ 50/60Hz) | Rated Current | Leakage Current (Max.) | Circuit Diagram | Figure | Temperature Rise (Max.) | |
|-----------------|---------------------------|---------------|------------------------|-----------------|--------|-------------------------|-----|
| 13-PDF-005-11-J | 440/250VAC | 5A | 1.5mA | 1 | A | 30°C | |
| 13-PDL-005-11-D | | | | | B | | |
| 13-PDF-010-11-J | | 10A | | | A | | |
| 13-PDL-010-11-D | | | | | B | | |
| 13-PDB-010-11-D | | 2 | | 30A | C | | |
| 13-PDB-015-11-D | | | | | | | 15A |
| 13-PDB-020-11-D | | | | | | | 20A |
| 13-PDB-025-11-D | | | | | | | 25A |
| 13-PDB-030-11-D | | | | | | | |

Note: Test Voltage 1500VAC one minute, line to ground.
Insulation Resistance: 300 MΩ min. at 500VDC.
Voltage Drop: 1V max. at rated current.

Power Line Filters Three Phase

13-PDF/PDL/PDB Series

Figure A

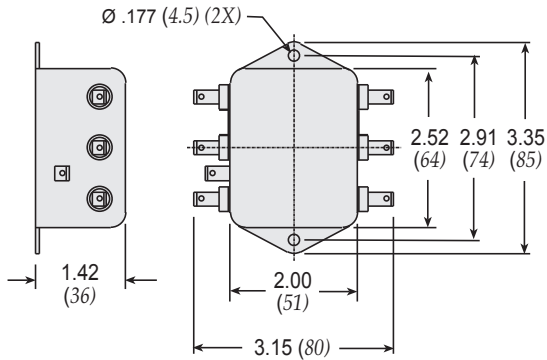

Figure B

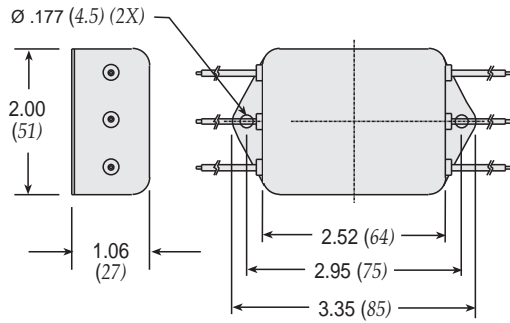
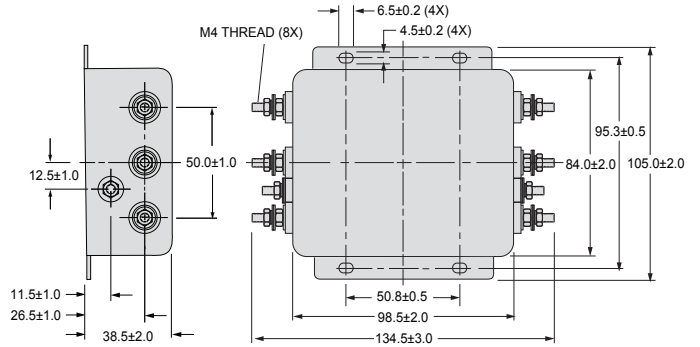
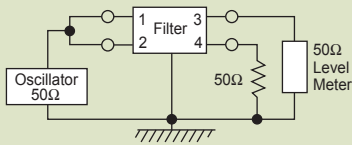

Figure C



Dimensions in inches (mm)

Common Mode



13-PDF-005;-010; PDL-005;-010 PDB-010

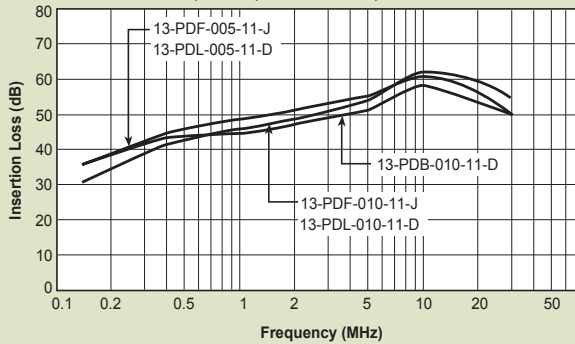

13-PDB-015;-020;-025;-030

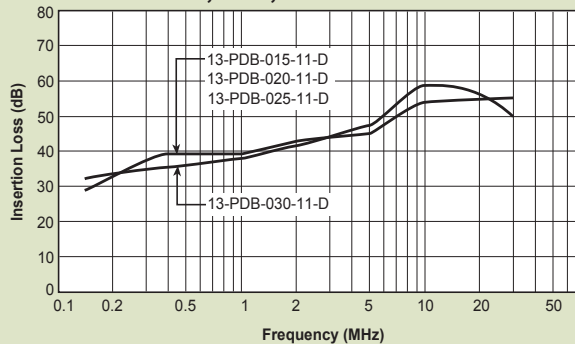

Normal Mode

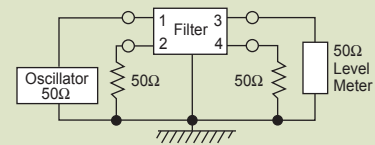

13-PDF-005;-010; PDL-005;-010 PDB-010

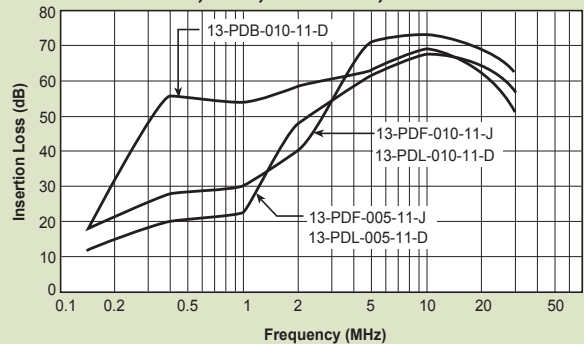

13-PDB-015;-020;-025;-030

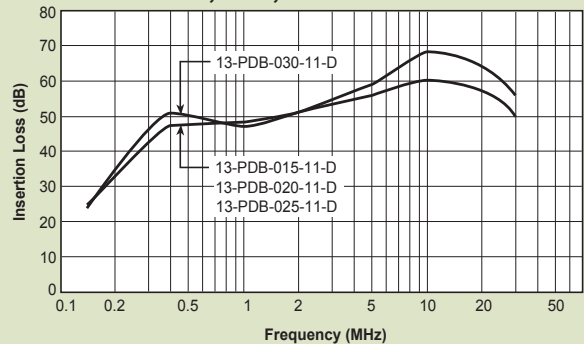

Power Line Filters Three Phase

High Performance



13-PWB Series

Features

- Excellent attenuation for high voltage impulse
- Metal case provides effective EMI shielding
- Epoxy molded for internal component reliability
- Excellent filtering characteristics for both normal and common mode
- Various current ratings available: from 5 to 150 Amps
- Operating temperature: -40°C to +85°C
- Designed for 3-phase, 4-line power systems

Applications

- Power supplies for data systems
- Industrial equipment (UPS, inverters and converters)
- Automation equipment
- Telecommunications systems and equipment

Circuit Diagram

Circuit 1

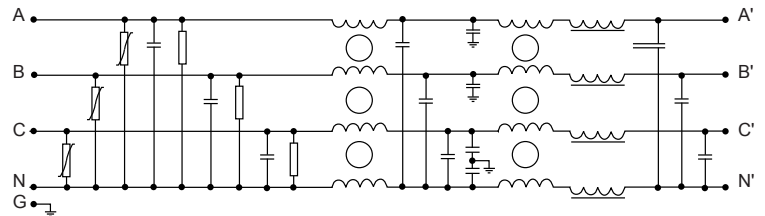

Circuit 2

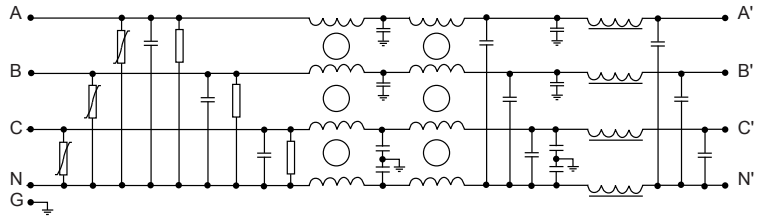

Specifications

| Model | Rated Voltage (@ 50/60Hz) | Rated Current | Leakage Current (Max.) | Circuit Diagram | Temperature Rise (Max.) |
|-----------------|---------------------------|---------------|------------------------|-----------------|-------------------------|
| 13-PWB-005-12-A | 480/277VAC | 5A | 4.5mA | 1 | 30°C |
| 13-PWB-010-12-B | | 10A | | | |
| 13-PWB-020-12-B | | 20A | | | |
| 13-PWB-035-12-C | | 35A | | | |
| 13-PWB-050-13-C | | 50A | 9.0mA | 2 | |
| 13-PWB-080-14-D | | 80A | 20mA | | |
| 13-PWB-100-14-D | | 100A | | | |
| 13-PWB-150-14-E | | 150A | | | |

Note: Test Voltage 1500VAC one minute, line to ground.
Insulation Resistance: 300 MΩ min. at 500VDC.
Voltage Drop: 1V max. at rated current.

Power Line Filters Three Phase

High Performance

13-PWB Series

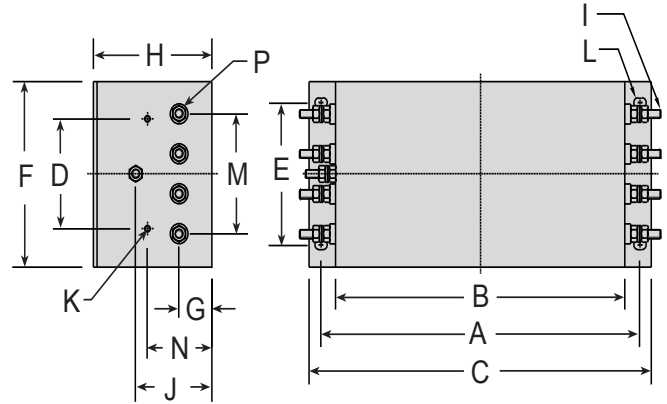

Dimensions

Dimensions in inches (mm)

| Model | A | B | C | D | E | F | G | H | I | J | K | M | N | P | L |
|-----------------|------------|------------|------------|----------|-----------|-----------|----------|----------|-----------------------|----------|----------|----------|----|------------------------|-----------------------|
| 13-PWB-005-12-A | 7.2 (184) | 6.3 (160) | 7.9 (202) | 2.4 (60) | 1.7 (44) | 3.5 (86) | .70 (18) | 2.3 (58) | M4 | 1.5 (38) | - | - | - | M4 | .25 x .37 (6.4 x 9.4) |
| 13-PWB-010-12-B | 9.6 (243) | 8.7 (220) | 10.3 (261) | | | 3.9 (100) | .98 (25) | | | 3.5 (90) | | | | | 1.8 (45) |
| 13-PWB-020-12-B | | | | 2.3 (58) | 2.9 (74) | 1.9 (49) | | M6 | .25 x .38 (6.4 x 9.6) | | | | | | |
| 13-PWB-035-12-C | | | | 2.4 (62) | 3.4 (86) | 2.2 (56) | | M8 | .25 x .38 (6.4 x 9.7) | | | | | | |
| 13-PWB-050-13-C | 13.9 (354) | 12.6 (320) | 15.1 (384) | 3.9 (99) | 6.1 (155) | 7.3 (185) | 1.2 (30) | M8 | M4 | 2.4 (61) | 2.4 (61) | 2.4 (61) | M8 | .25 x .38 (6.4 x 9.8) | |
| 13-PWB-080-14-D | | | | | | | | | | | | | | .25 x .39 (6.4 x 9.9) | |
| 13-PWB-100-14-D | | | | | | | | | | | | | | .25 x .36 (6.4 x 9.10) | |
| 13-PWB-150-14-E | | | | | | | | | | | | | | .25 x .36 (6.4 x 9.11) | |

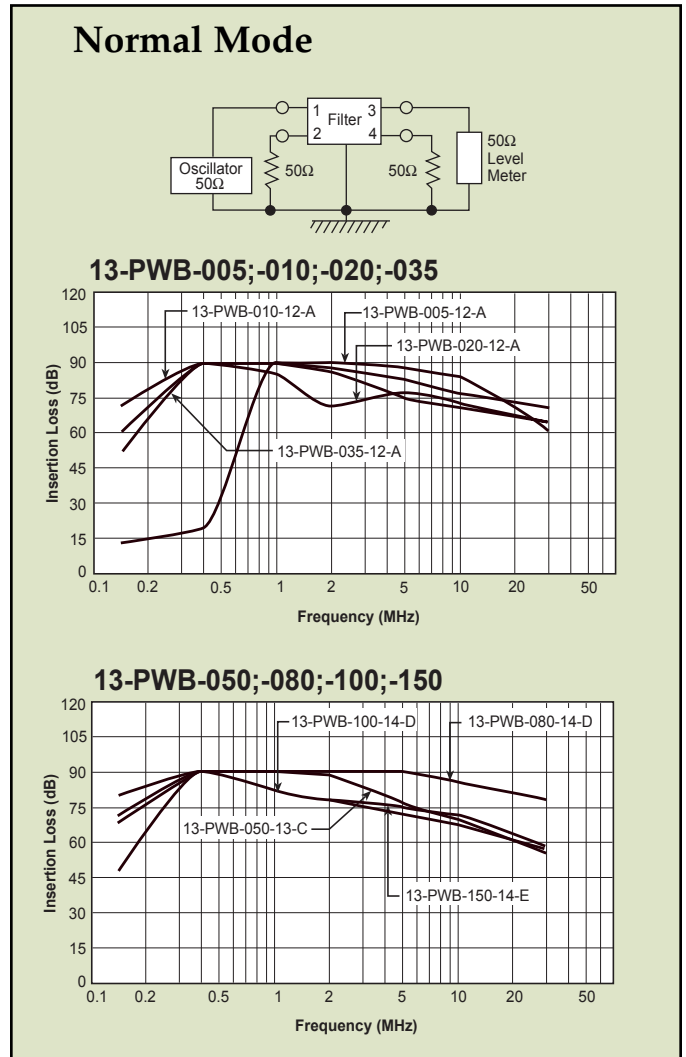
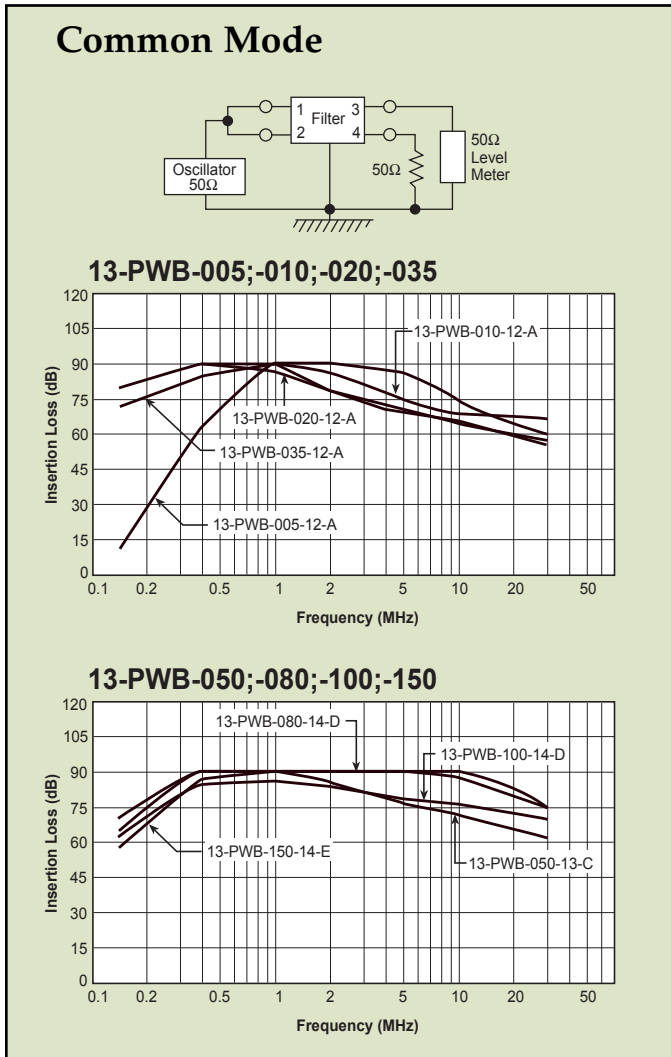

Power Line Filters Three Phase

High Performance



13-PDB Series

Features

- Excellent attenuation for high voltage impulse
- Metal case provides effective EMI shielding
- Epoxy molded for internal component reliability
- Excellent filtering characteristics for both normal and common mode
- Various current ratings available: from 5 to 200 Amps
- Operating temperature: -40°C to +85°C
- Designed for 3-phase, 3-line connection systems

Applications

- Digital equipment
- Industrial equipment (UPS, inverters and converters)

Circuit Diagram

Circuit 1

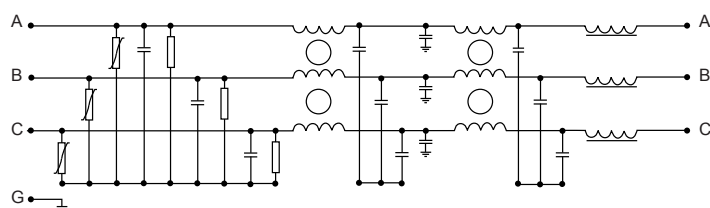

Circuit 2

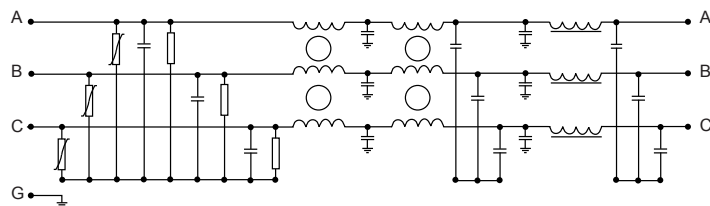

Specifications

| Model | Rated Voltage (@ 50/60Hz) | Rated Current | Leakage Current (Max.) | Circuit Diagram | Temperature Rise (Max.) |
|-----------------|---------------------------|---------------|------------------------|-----------------|-------------------------|
| 13-PDB-005-12-A | 480/277VAC | 5A | 4.5mA | 1 | 30°C |
| 13-PDB-010-12-A | | 10A | | | |
| 13-PDB-020-12-B | | 20A | | | |
| 13-PDB-035-12-B | | 35A | | | |
| 13-PDB-050-12-B | | 50A | 9.0mA | 1 | |
| 13-PDB-080-13-C | | 80A | | | |
| 13-PDB-100-14-C | | 100A | 20mA | 2 | |
| 13-PDB-150-14-C | | 150A | | | |
| 13-PDB-200-14-D | | 200A | | | |

Note: Test Voltage 2250VDC one minute, line to ground.
Insulation Resistance: 500MΩ.

Power Line Filters Three Phase

High Performance

13-PDB Series

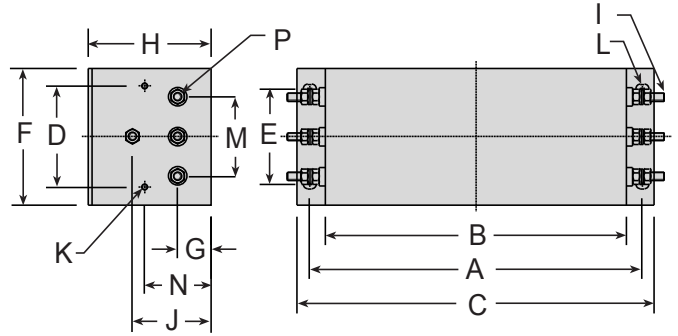

Dimensions

Dimensions in inches (mm)

| Model | A | B | C | D | E | F | G | H | I | J | K | M | N | P | L | | | | | | | |
|-----------------|---------------|---------------|---------------|-------------|--------------|--------------|-------------|-------------|----|-------------|----|-------------|-------------|----|-----------------------|--|--|--|--|-------------|-----------------------|------------------------|
| 13-PDB-005-12-A | 7.2 (184) | 6.3 (160) | 7.9 (202) | 1.6 (42) | 2.4 (60) | 3.3 (86) | .70 (18) | 2.3 (58) | M4 | 1.5 (38) | - | - | - | M4 | .25 x .37 (6.4 x 9.4) | | | | | | | |
| 13-PDB-010-12-A | | | | | | | | | M4 | | | | | M4 | .25 x .37 (6.4 x 9.5) | | | | | | | |
| 13-PDB-020-12-B | | | | | | | | | M6 | 2.3 (58) | - | 2.9 (74) | 1.9 (49) | M6 | .25 x .38 (6.4 x 9.6) | | | | | | | |
| 13-PDB-035-12-B | 9.6 (243) | 8.7 (220) | 10.3 (261) | 2.3 (58) | 2.7 (70) | 3.9 (100) | .98 (25) | | | | | | | | | | | | | | .25 x .38 (6.4 x 9.7) | |
| 13-PDB-050-12-B | | | | | | | | | | | | | | | | | | | | | .25 x .38 (6.4 x 9.8) | |
| 13-PDB-080-13-C | | | | | | | | 3.5 (90) | M8 | 2.4 (62) | M4 | 3.3 (86) | 2.2 (56) | M8 | .25 x .39 (6.4 x 9.9) | | | | | | | |
| 13-PDB-100-14-C | 13.9 (354) | 12.6 (320) | 15.1 (384) | 2.5 (66) | 6.1 (155) | 7.3 (185) | 1.2 (30) | | | | | | | | | | | | | | | .25 x .36 (6.4 x 9.10) |
| 13-PDB-150-14-C | | | | | | | | | | | | | | | | | | | | | | .25 x .36 (6.4 x 9.11) |
| 13-PDB-200-14-D | | | | | 7.5 (190) | 8.6 (220) | 1.4 (35) | | | | | | | | 3.9 (100) | | | | | 2.4 (61) | | .25 x .36 (6.4 x 9.12) |

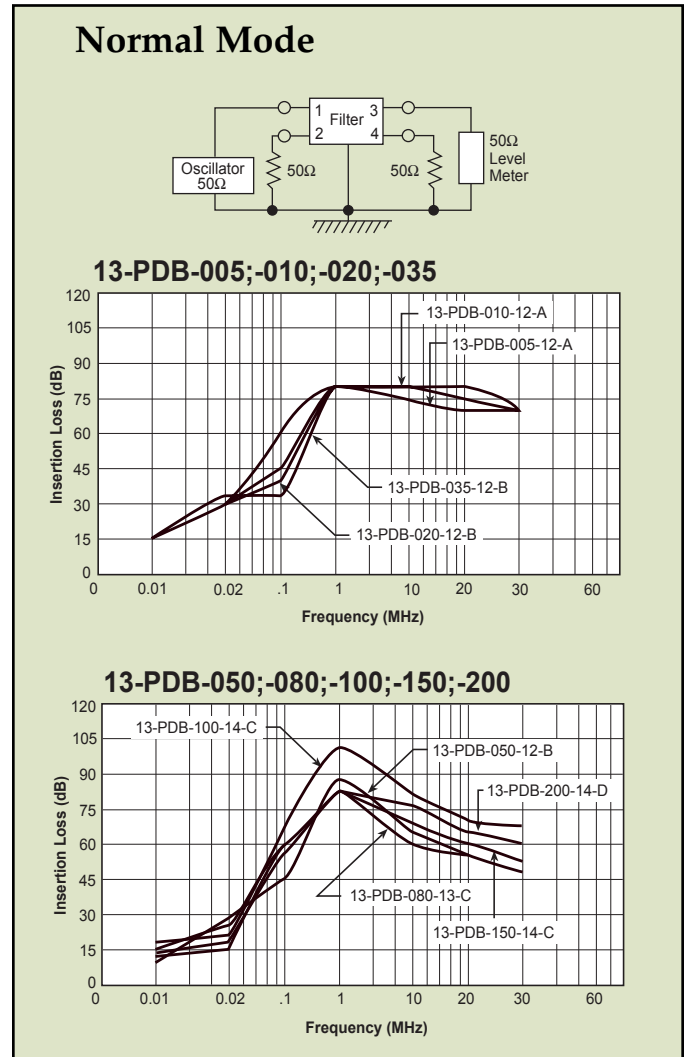
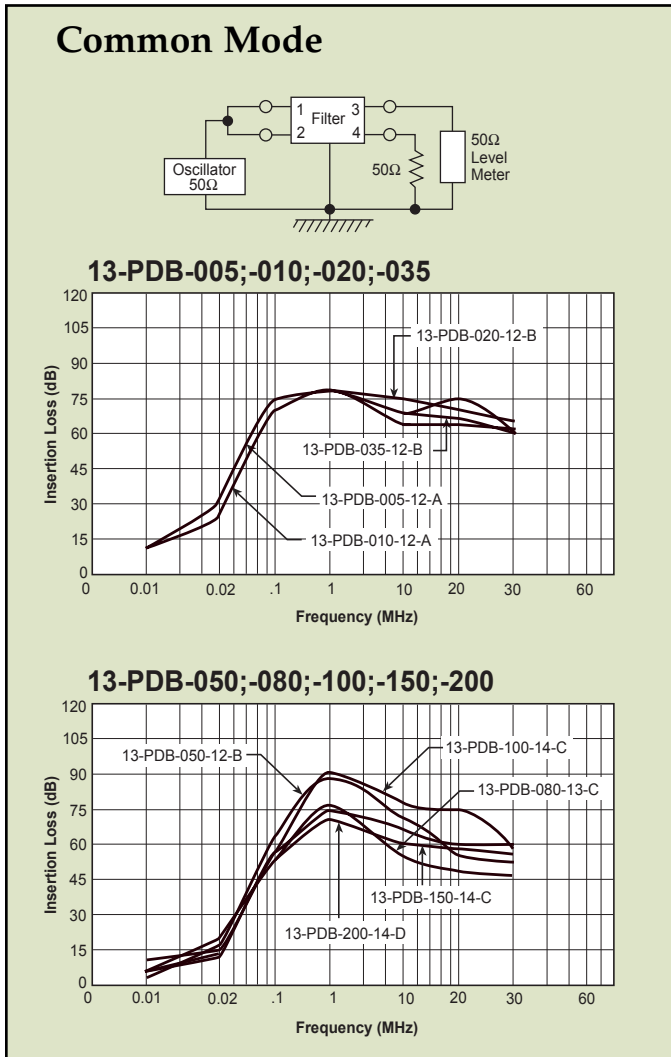

Commercial-Off-The-Shelf (COTS) Filters

API Technologies' Spectrum Control Brand now offers COTS single line feed-through EMI filters that are the commercial equivalent the M15733-PRF/72, M15733-PRF/73 and M15733-PRF/74. These reliable AC and DC high performance filters meet all the requirement of the QPL equivalent. The filters provide an excellent source of filtering in a compact package and are well suited for the military and aerospace industries. They filter up to 500 A with an attenuation of 4 to 90 dB from 1 MHz to 1 GHz and voltage rating of 130 VDC to 250 VAC.



| MIL part M15733/ | Our Commercial Equivalent |
|------------------|---------------------------|
| 72-0034 | 5004-7053-100-A |
| 72-0046 | 5004-7053-100-A |
| 72-0049 | 5004-7059-100-A |
| 72-0053 | 5004-7065-100-A |
| 73-0034 | 5004-7058-125-A |
| 73-0043 | 5004-7053-100-A |
| 73-0043 | 5004-7058-125-A |
| 73-0046 | 5004-7052-125-A |
| 73-0049 | 5004-7058-125-A |
| 73-0051 | 5004-7059-250-A |
| 73-0053 | 5004-7064-125-A |
| 74-0030 | 5004-7041-250-A |
| 74-0036 | 5004-7047-250-A |
| 74-0042 | 5004-7053-250-A |
| 74-0045 | 5004-7059-250-A |



Shielded Filters

API has developed a new MRI filter product line which provides MRI/RF shielding solutions for medical, commercial and government applications. Offers 100 dB insertion loss per MIL-STD 220 from 14 KHz to 10 GHZ.

Shielded Foam Filters

| P/N Series | Configuration* | Description |
|------------|----------------|--------------------|
| 52-1490 | 1 x 5 | 1 x 5 A, 277 VAC |
| | 1 x 30 | 1 x 30 A, 277 VAC |
| | 1 x 100 | 1 x 100 A, 277 VAC |
| | 1 x 150 | 1 x 150 A, 277 VAC |
| | 1 x 200 | 1 x 200 A, 277 VAC |
| | 1 x 225 | 1 x 225 A, 277 VAC |
| | | 2 x 5 |
| 2 x 30 | | 2 x 30 A, 277 VAC |
| 2 x 50 | | 2 x 50 A, 277 VAC |
| 2 x 60 | | 2 x 60 A, 277 VAC |

* Add to P/N series (eg. 52-1490-1x5)

Options are available with or without discharge light "L" at the end of the part (52-1490-1x5L). Custom configurations are available. Consult factory.



Military/Aerospace Multisection Filters



API Technologies' Spectrum Control brand will address virtually any requirement for a military/custom power product. Our engineering expertise and vertical integrations reduce your speed to market as well as saves you money. Our electromagnetic compatibility expertise in the tempest arena can help you meet MIL-F-15733 and MIL-STD 461 standard requirements.

Features

- High common and differential mode attenuation
- Standard designs up to 400 Amps
- Excellent insertion loss characteristics up to 10 GHz
- Voltage rating 115-250VAC and 400VDC up to 400 Hz
- Available to meet TEMPEST and FCC requirements
- Custom designs for application-specific requirements

Applications

- Military
- Commercial and military/aerospace
- Secured communications
- Switching power supplies
- Data processing equipment
- Ruggedized computers
- Radar
- Electronic warfare
- Ground/air weapon systems
- Satellites
- Ship board systems
- Land based vehicles
- Fixed and mobile control stations

Test Specifications

The high performance power line filters shown on pages 59 and 60 are designed to meet the following criteria.

The information shown can be used as a basis for filter specifications. (Contact factory for additional details).

| Test Group | Order of Test | Examination or Test | Test Method (Per MIL-STD-202) | Post Test Requirements |
|------------|---------------|---------------------------|--|---|
| IIA | 1 | Voltage Drop | Paragraph 4.6.8 of MIL-F-15733 | Three percent of rated voltage max. |
| | 2 | Leakage Current | UL 1283 | Per applicable specification |
| | 3 | Temperature Rise | MIL-F-15733 Paragraph 4.6.4 | 25°C max. |
| | 4 | Terminal Strength | Method 211, Condition A | No evidence of loosening or rupture. 5 lb. applied force. Line Cords: 35 Lbs. |
| IIB | 1 | Shock, Medium Impact | Method 213, Condition G | Must pass DWV and Insertion Loss |
| | 2 | Vibration, High Frequency | Method 204, Condition A | Monitor for shorts or open |
| | 3 | Thermal Shock | Method 107, Test Condition A | Pass 90% DWV IR to be 30% of initial |
| | 4 | Humidity | Method 107, Condition B, except temperature equals 25°C | Pass 90% DWV IR to be 30% of initial |
| III | 1 | Life | Method 108, Condition D 1.2 x Rated AC voltage at max. operating temp. or 1.4 x DC voltage | Pass 90% DWV insulation resistance to be 30% of initial. |

Military/Aerospace Multisection Filters

Insertion Loss

52-600-001

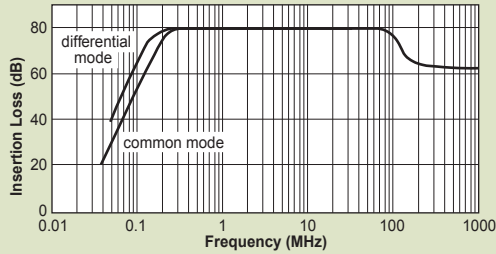

52-600-002

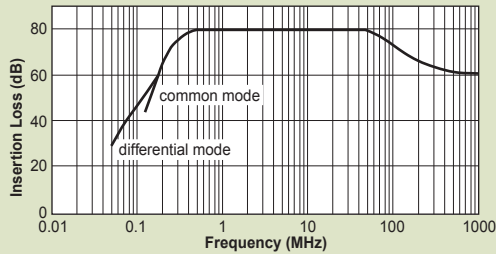

Circuit Schematic

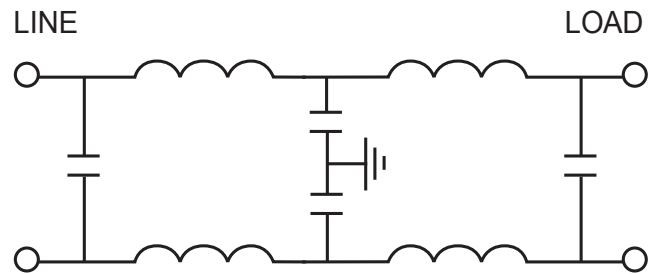

Dimensions

52-600-001
52-600-002

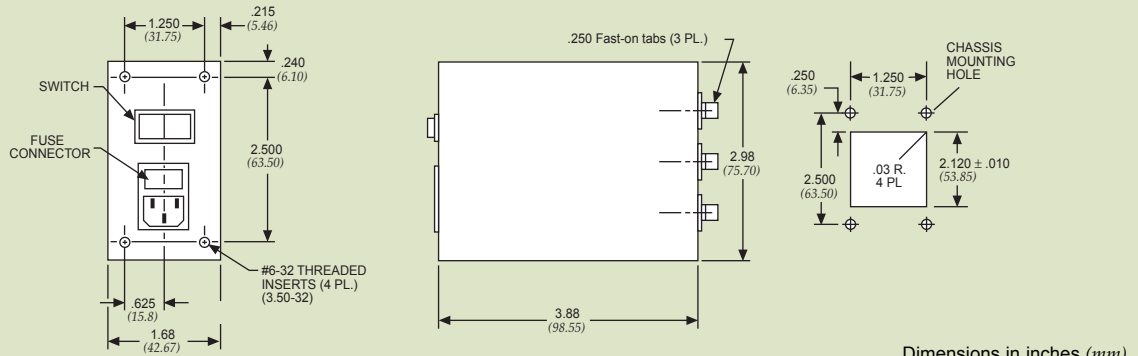

Dimensions in inches (mm)

| Model | Current Rating | Voltage Rating | Temperature Rating | DCR. max. (ohms) | Leakage Current (max.) | Mode (max.) | Minimum Insertion Loss (db) Per MIL-STD-220 | | | | | | |
|------------|----------------|---------------------|--------------------|------------------|------------------------|-------------|---|------|------|----|-----|------|----|
| | | | | | | | 50K | 150K | 300K | 1M | 10M | 100M | 1G |
| 52-600-001 | 5A | 120/240VAC 60 Hz | -40°C to +65°C | .20 | 1 mA | COMM | 33 | 65 | 80 | 80 | 80 | 80 | 60 |
| | | | | | | | 37 | 65 | 80 | 80 | 80 | - | - |
| 52-600-002 | 10A | 120/240VAC 60 Hz | -40°C to +65°C | .10 | 1 mA | COMM | - | 50 | 70 | 80 | 80 | 70 | 60 |
| | | | | | | | 25 | 50 | 75 | 80 | 80 | - | - |

Consult factory for UL/CSA approval availability.

Military/Aerospace Multisection Filters

Insertion Loss
52-523-002

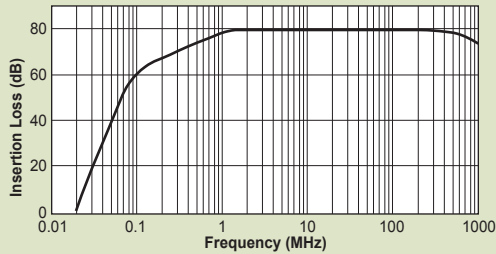

Circuit Schematic

52-523-002

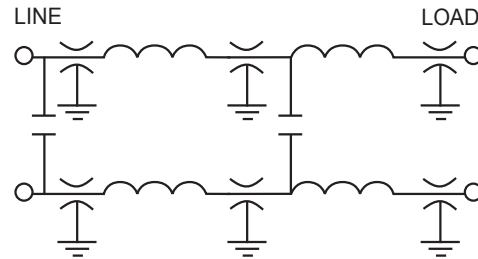

Dimensions

52-523-002

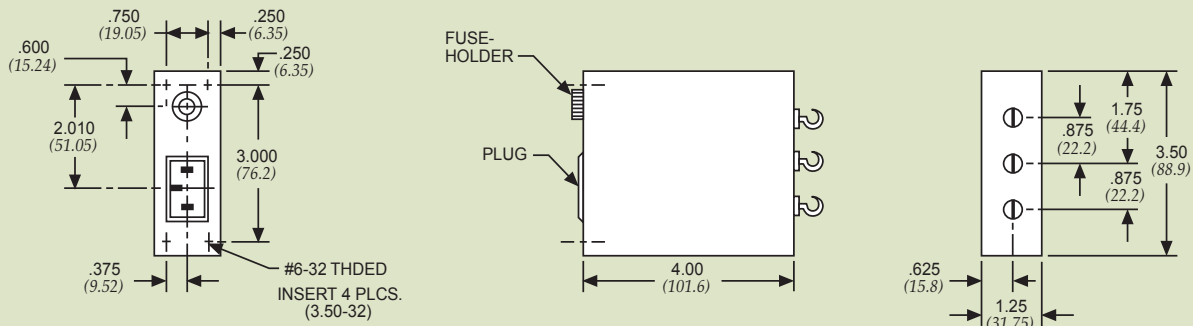

Dimensions in inches (mm)

| Model | Current Rating | Voltage Rating | Temperature Rating | DCR max. (ohms) | Leakage Current (max.) | Mode (max.) | Minimum Insertion Loss (db) Per MIL-STD-220 | | | | | | |
|------------|----------------|---------------------|--------------------|-----------------|------------------------|-------------|---|------|------|----|-----|------|----|
| | | | | | | | 50K | 150K | 300K | 1M | 10M | 100M | 1G |
| 52-523-002 | 5A | 120/240VAC 60 Hz | -40°C to +65°C | .25 | 1 mA | COMM | - | 55 | 60 | 80 | 80 | 70 | 60 |
| | | | | | | | DIFF | - | 50 | 60 | 80 | 80 | - |

Consult factory for UL/CSA approval availability.

Military/Aerospace Multisection Filters

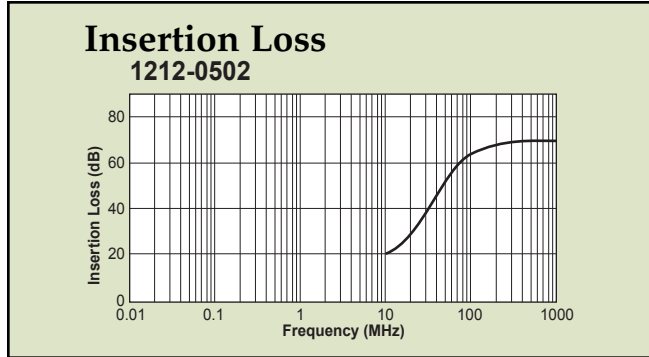

Circuit Schematic

1212-0502

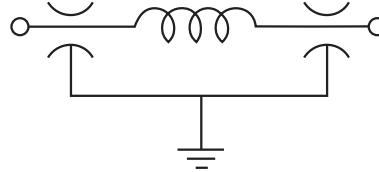

Dimensions

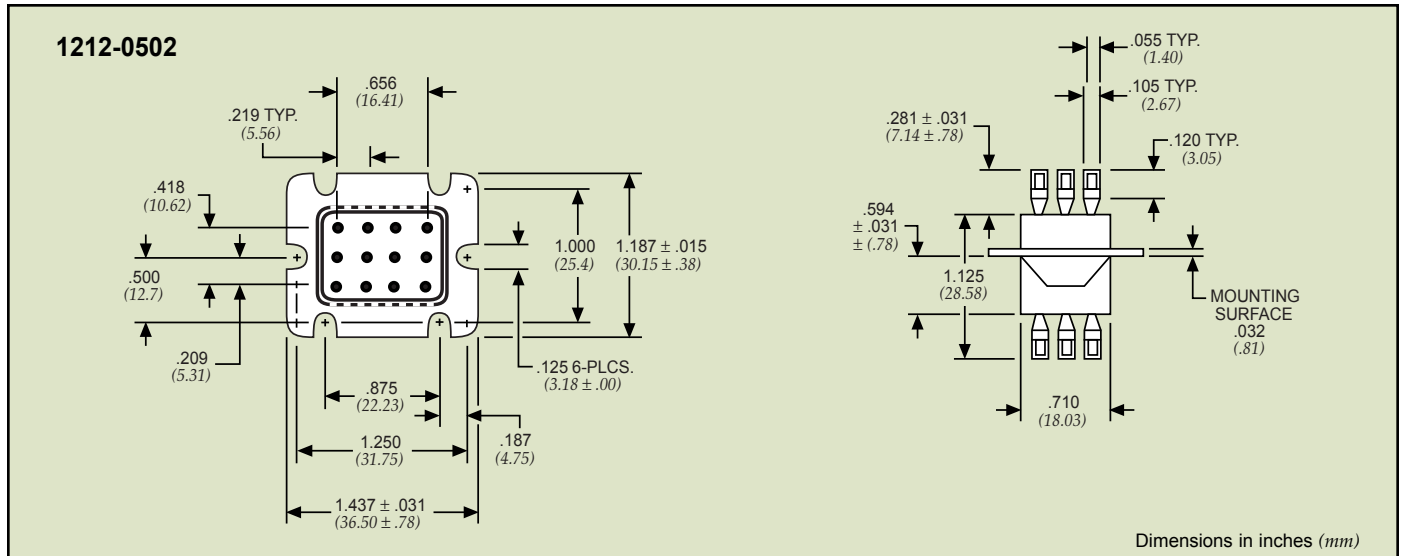

| Model | Current Rating | Voltage Rating | Temperature Rating | DCR max. (ohms) | Leakage Current (max.) | C _x Value | Minimum Insertion Loss (db) Per MIL-STD-220 | | | |
|-----------|----------------|------------------------|--------------------|-----------------|------------------------|----------------------|---|------|------|----|
| | | | | | | | 10M | 100M | 500M | 1G |
| 1212-0502 | 10A | 350VDC 240VAC 60 Hz | -55°C to +125°C | .01 | 1 mA | 5000pF | 20 | 65 | 70 | 70 |

Consult factory for UL/CSA approval availability.

Military/Aerospace Multisection Filters

Secure Communications

API's electromagnetic compatibility expertise in the secure communication or "TEMPEST" arena is represented by this group of high performance filters. These units are especially well suited for use in MIL-STD-461 applications to reduce conducted emissions. The filters are manufactured with glass sealed terminals and connectors.

Features

- Excellent insertion loss profile
- Available for DC & AC applications up to 400 Hz
- Available for 3-14 Amp applications
- Custom systems can be designed to your specific needs



Filter Schematic A

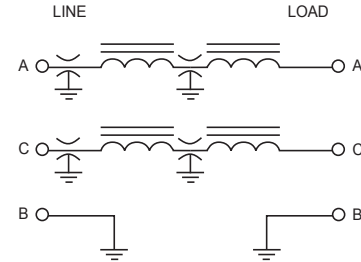

Filter Schematic B

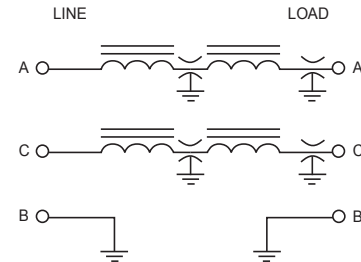

Dimensions

52-378-002

#8-32 UNC THD. INSERTS (4.17-32) .350 DEEP, 2 PLACES (8.89)

CONNECTOR #8001-14S-7P-A3 MATES WITH MS-3106-14S-7S

Dimensions in inches (mm)

Insertion Loss

52-378-002, -004 MIL-STD-220

| Model | Current Rating | Voltage Rating | Temperature Range | DCR max. (ohms) | Leakage Current (max.) | Schematic | Minimum Insertion Loss (db) | | | | | | |
|------------|----------------|---------------------------|-------------------|-----------------|------------------------|-----------|-----------------------------|---------|---------|-------|--------|---------|-------|
| | | | | | | | 50 KHz | 150 KHz | 300 KHz | 1 MHz | 10 MHz | 100 MHz | 1 GHz |
| 52-378-001 | 3 Amps | 240VAC 60 Hz Line to Line | -55°C to 85°C | .3 | 50 mA | A | 30 | 60 | 70 | 80 | 80 | 70 | 70 |
| 52-378-002 | 5 Amps | 240VAC 60 Hz Line to Line | -55°C to 85°C | .2 | 50 mA | B | 24 | 64 | 70 | 80 | 80 | 70 | 70 |
| 52-378-004 | 5 Amps | 240VAC 60 Hz Line to Line | -55°C to 85°C | .2 | 50 mA | A | 34 | 64 | 70 | 80 | 80 | 70 | 70 |
| 52-378-005 | 3 Amps | 240VAC 60 Hz Line to Line | -55°C to 85°C | .3 | 50 mA | B | 40 | 70 | 80 | 80 | 80 | 70 | 60 |

Military/Aerospace Multisection Filters

Insertion Loss

52-387-010, -003 MIL-STD-220
52-409-001 MIL-STD-220

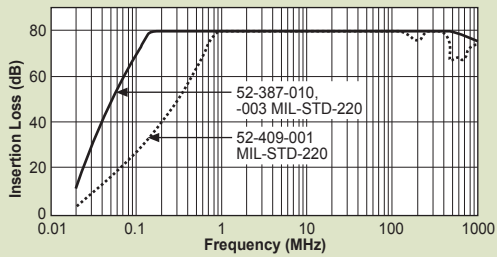

Filter Schematic C

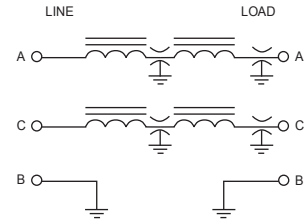

Filter Schematic D

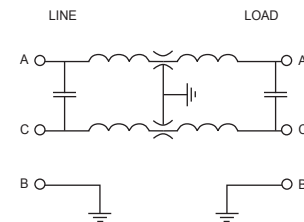

Filter Schematic E

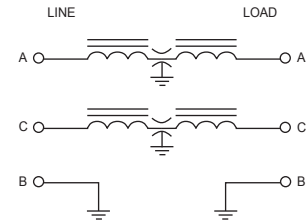

3 Phase and 400 Hz models available.
Please consult the factory.

Dimensions

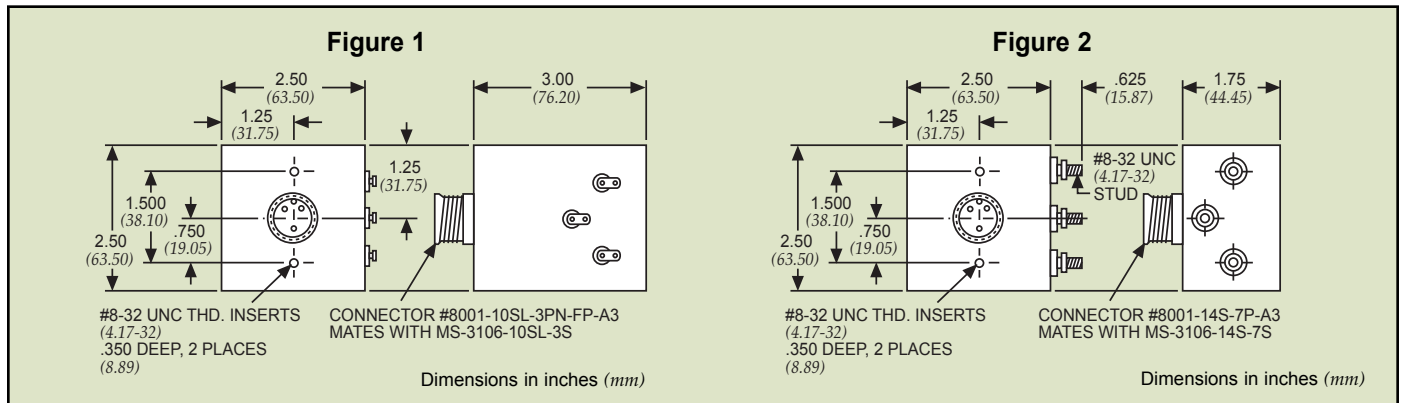

| Model | Fig. | Current Rating | Voltage Rating | Temperature Range | DCR max. (ohms) | Leakage Current (max.) | Sch. | Mode | Minimum Insertion Loss (db) | | | | | | |
|------------|------|----------------|-------------------------------|-------------------|-----------------|------------------------|------|--------------|-----------------------------|---------|---------|---------|--------|---------|-------|
| | | | | | | | | | 50 KHz | 150 KHz | 300 KHz | 1.0 MHz | 10 MHz | 100 MHz | 1 GHz |
| 52-387-010 | 1 | 10 Amps | 240VAC 60 Hz Line to Line | -55°C to 85°C | .2 | 50 mA | C | common | 24 | 60 | 70 | 80 | 80 | 70 | 70 |
| 52-387-012 | 1 | 5 Amps | 240VAC 400 Hz Line to Line | -55°C to 85°C | .2 | 5 mA | D | common | 34 | 64 | 70 | 80 | 80 | 70 | 70 |
| | | | | | | | | differential | 30 | 30 | 70 | 80 | 80 | - | - |
| 52-409-001 | 2 | 14 Amps | 240VAC 60 Hz Line to Line | -55°C to 85°C | .04 | 50 mA | E | common | 14 | 30 | 45 | 80 | 80 | 70 | 60 |

Military/Aerospace Multisection Filters

Secure Communications

Features

- Meets applicable sections of MIL-F-15733
- Excellent performance
- Integral IEC connector
- Available with integral fused IEC connector and two pole switch
- Current ratings to 15 Amps
- Custom designs available

Electrical Specifications

Rated current ranges 3, 6, 10, 15 Amps

Rated voltage..... 115-250VAC

Operating frequency..... 50-60 Hz

Maximum leakage current

 @115VAC 60 Hz..... 1.2 mA

 @250VAC 50 Hz..... 2.5 mA

Test voltage

 Line-to-Line..... 1450VDC

 Line-to-Ground..... 2250VDC



Part Numbering System:

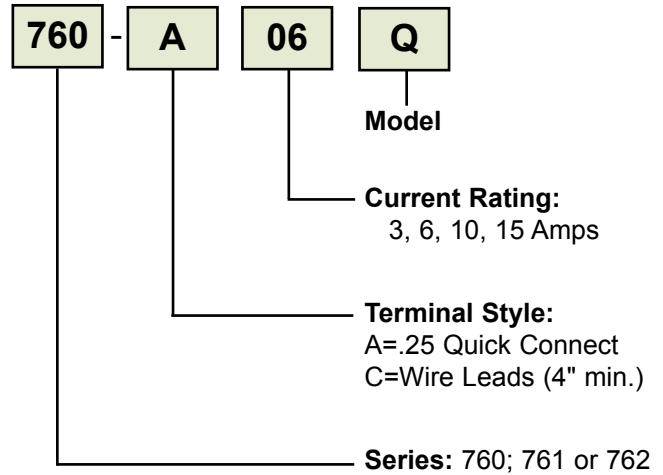

Insertion Loss

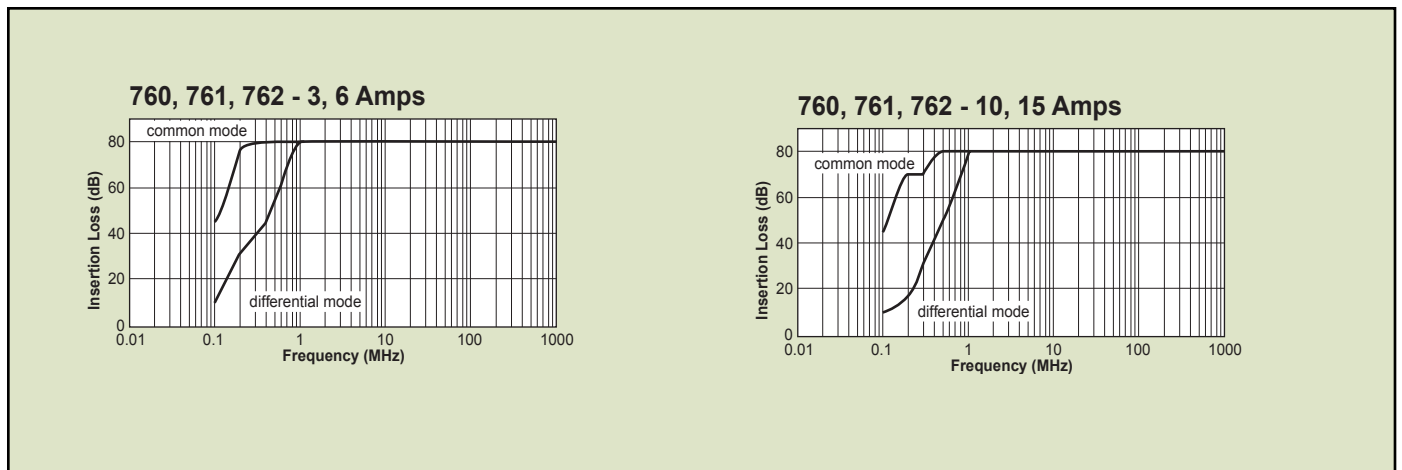

Common Mode (CM) is tested in a 50 ohm system with all lines tied together on the line and load sides of the filter.
Differential Mode (DM) is tested in a 50 ohm system using a 180° phase splitter on both sides of the filter.

Military/Aerospace Multisection Filters

Dimensions - 760 Series

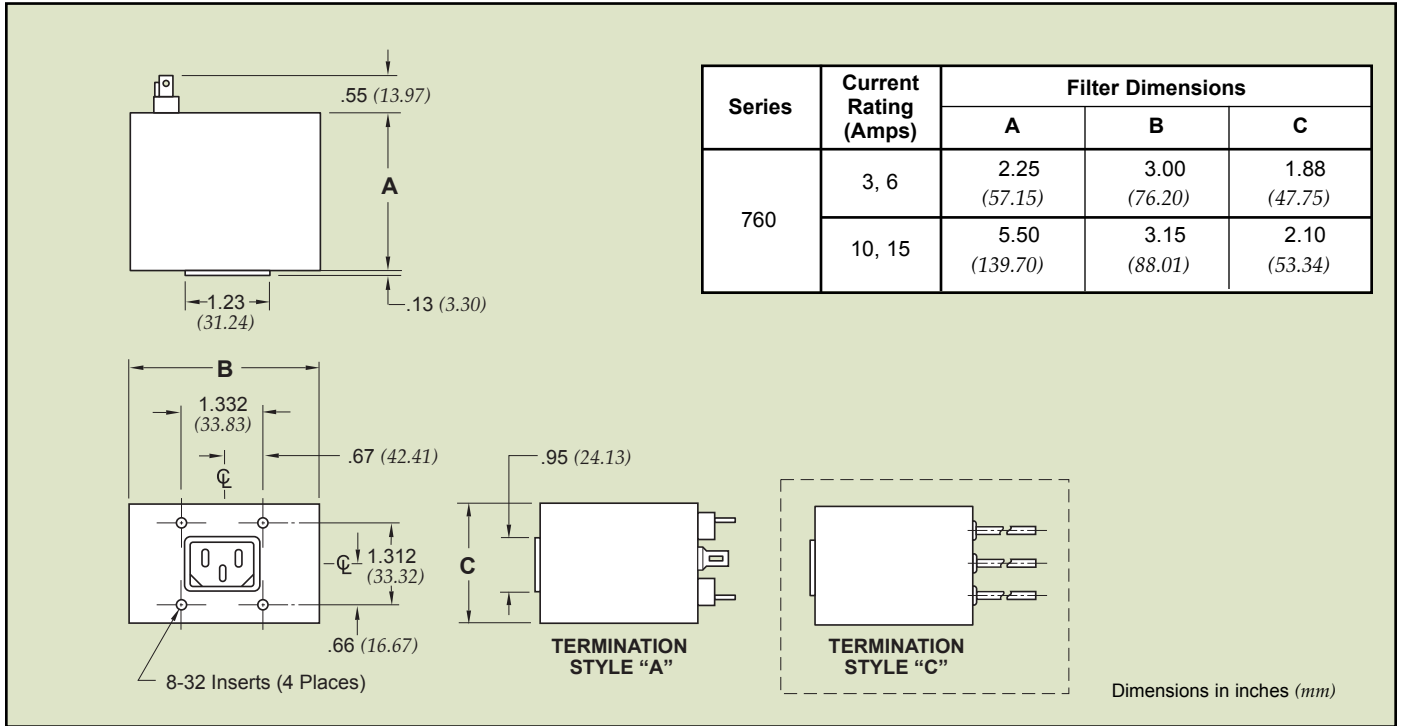

Dimensions - 761, 762 Series

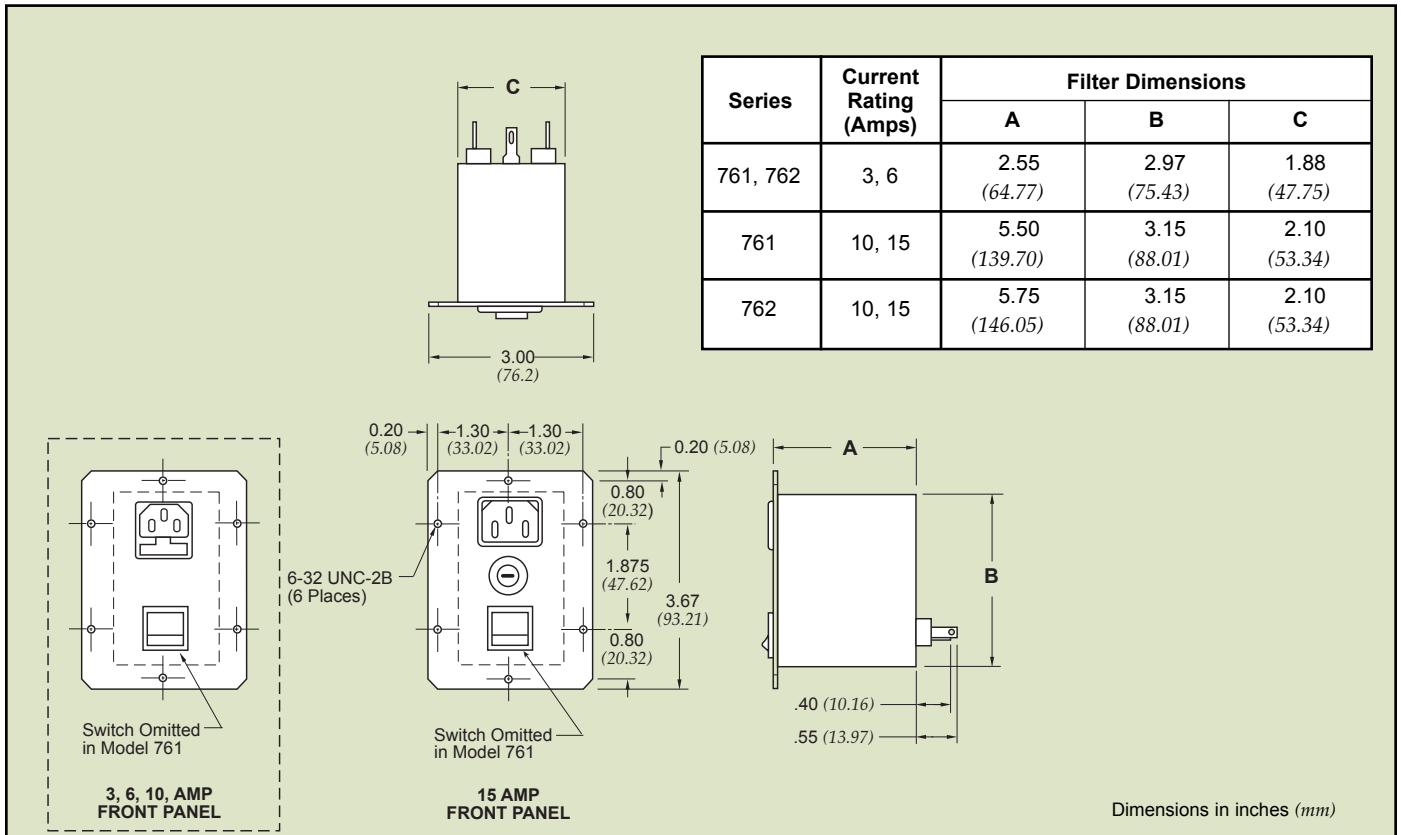

EMI Power Filter Solutions

Military and Aerospace

API Technologies has a long history of partnering with leading suppliers of the defense industry. Our ability to find solutions to suppress or eliminate electromagnetic interference (EMI) allows us to provide the high reliability filters required for military and aerospace applications. API's Spectrum Control brand can design your custom filter with a unique mechanical package for those unusual or tight fitting spaces, higher performance filtering and the voltage rating you need to address all of your AC and DC power issues.

Communications

API's Spectrum line of power filter solutions can create an agency-approved product that will filter and condition the power to your communications infrastructure equipment, as well as eliminate emissions that can contaminate your distributed AC and DC power. Our custom power filters will incorporate all the components and the filtering in one complete package to save you space, time and money. And as a vertically integrated supplier, API offers global low cost manufacturing which allows us to produce fast prototypes and a quicker time to market.

Medical

Our many years of experience in providing EMI/RFI solutions has given us the know-how to design products to meet the specific constraints and requirements of the medical industry. Much of the medical equipment used today requires complete suppression of any and all EMI, as well as low-leakage, nonmagnetic properties to prevent negatively affecting surrounding equipment. We will design and build a high reliability, high performance custom power filter to meet your system and all EN requirements.

Industrial

At API, we do everything from package design and metalworking to EMI filtering to EMC testing, which means a lower cost for you. Our engineers will design and build a custom power filter that will satisfy global EMC regulations, improve speed-to-market times, overcome space constraints and withstand harsh environmental conditions. Our plug-and-play designs cover a range of industrial and instrumentation applications that will address any of your power filtering needs with current ratings as high as 500 Amps.

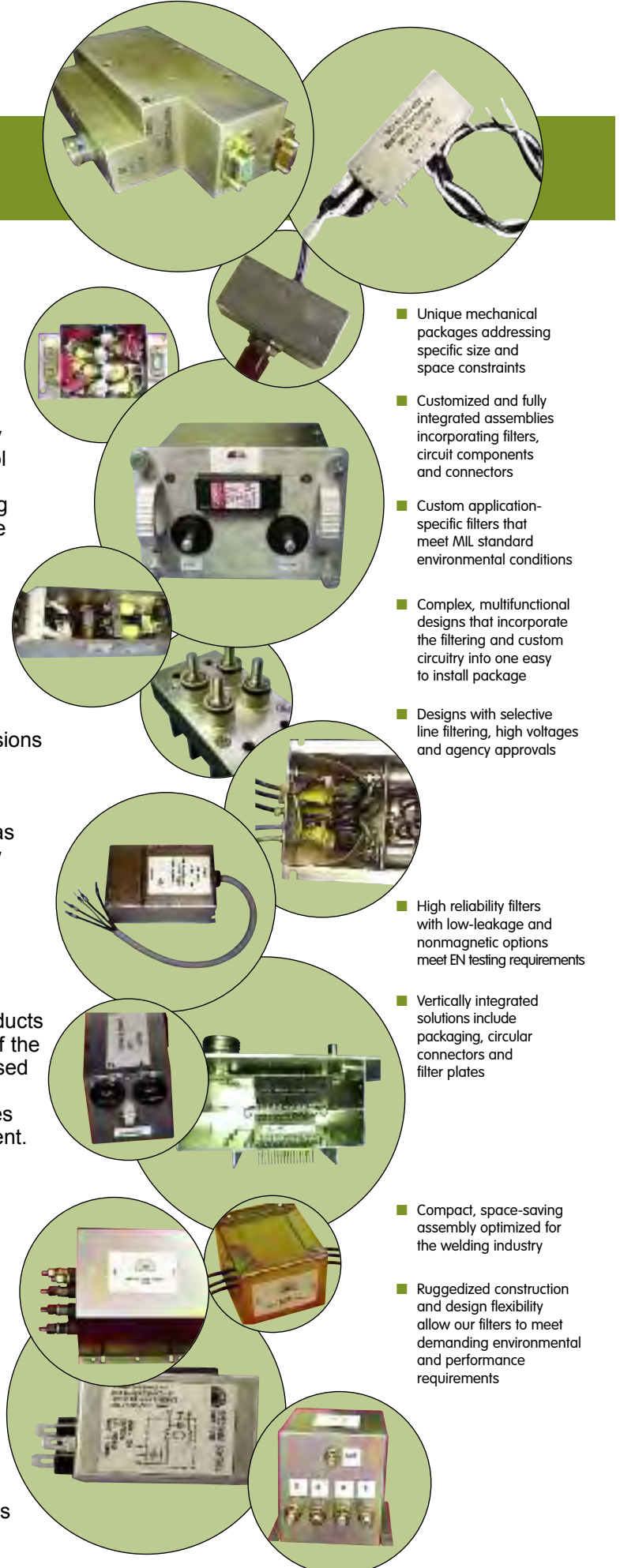

- Unique mechanical packages addressing specific size and space constraints
- Customized and fully integrated assemblies incorporating filters, circuit components and connectors
- Custom application-specific filters that meet MIL standard environmental conditions
- Complex, multifunctional designs that incorporate the filtering and custom circuitry into one easy to install package
- Designs with selective line filtering, high voltages and agency approvals
- High reliability filters with low-leakage and nonmagnetic options meet EN testing requirements
- Vertically integrated solutions include packaging, circular connectors and filter plates
- Compact, space-saving assembly optimized for the welding industry
- Ruggedized construction and design flexibility allow our filters to meet demanding environmental and performance requirements

Power Film Capacitors

API Technologies' Spectrum Control brand introduces its new line of power film capacitors, designed using the latest film technology to achieve maximum capacitance density. Available in application-specific packages and terminations, these new power film capacitors feature rugged construction to withstand even the harshest environments.

Features and Specifications

- Metallized: polyester, polypropylene and polyphenylene sulphide film dielectrics
- Temperature ratings -55°C up to + 150°C
- Low ESR and ESL construction
- Rugged construction for even the harshest environments
- In-house electrical, environmental and reliability testing verification
- Standard designs up to 10,000 VDC/ 750 VAC
- Standard capacitance values up to 10,000 µF
- Ripple currents up to 400 Arms

Model Features & Ordering Information

High Power Capacitor Series

- Metallized polypropylene, low loss
- Flame retardant tape wrap and epoxy end fill
- Axial leads or tab termination
- Low ESL & ESR design for high ripple currents
- Temperature -55°C to +105°C
- Voltages up to 2,000 VDC
- Capacitance 0.015 µF – 3.3 µF



Applications

- Renewable energy inverters – solar converters, wind turbines and fuel cells
- Electric vehicle power conversion and battery chargers
- Aircraft power conversion systems
- Radar systems, laser pulse power
- Industrial welders, elevators, rail traction drives
- High voltage power supplies, switching power supplies
- Medical imaging equipment, defibrillators

Example: **55PP-600-106-K**

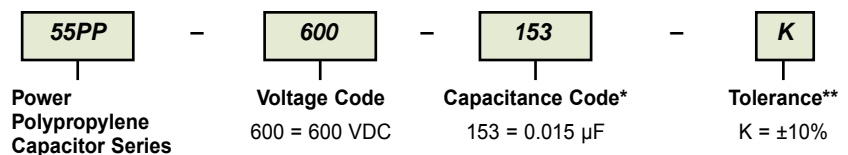

* Capacitance in Picofarads. The first two digits are significant and the third represents the number of zeros.

** Indicates standard tolerance. Others available upon request.

55DC Link Series Power Film Capacitors

API's Spectrum Control line of high reliability DC link capacitors are ideal for power inverter applications which require superior life under harsh operating conditions, such as electric vehicle power conversions, battery chargers, aircraft power conversion systems and radar systems. Featuring a compact and cost-effective design, DC link capacitors are manufactured from segmented, self-healing metallized polypropylene, resulting in longer life expectancy (+100,000 hrs). With high capacitance density and ripple current capabilities, API's DC link capacitors are the ideal replacement for electrolytic capacitors.

Specifications

- Capacitance range: 160 μ F to 680 μ F standard (others available upon request)
- Capacitance tolerance: +/- 10% standard
- Rated voltage: 900 to 1300 VDC
- Operating temperature range: -55°C to +85°C standard (+105°C upon special request)
- Test voltage between terminals: 150% rated voltage for 10 sec
- Test voltage between terminals and housing: 5kVDC for 10 sec
- Enclosure/construction: aluminum housing, brass terminals with dry resin, UL 94V-0 encapsulant
- Low ESR and ESL
- RoHS compliant

55DC Link Series Part Numbering System



Series

Voltage

Capacitance

Terminal Code

901 = 900 VDC
112 = 1100 VDC
132 = 1300 VDC

- = Segmented
S = Standard (non-segmented)

321 = 320 μ F
441 = 440 μ F

- = M12 stud
N = No M12 stud

M = M8 External Thread, 45mm center-center
F = M5 Internal Thread, 45mm center-center
S = M6 Internal Thread, 45mm center-center

MA = M8 External Thread, 32mm center-center
FA = M5 Internal Thread, 32mm center-center
SA = M6 Internal Thread, 32mm center-center

| Part Number | Rated Voltage (VDC) | Capacitance (μ F) | D Diameter (mm) | Height H (mm) | Typ ESR (mOhms) | Typ ESL (nH) | Irms Max. (A) M | Weight (kg) |
|-----------------|---------------------|------------------------|-----------------|---------------|-----------------|--------------|-----------------|-------------|
| 55DC-901-321-XX | 900 | 320 | 90 | 97 | 2.1 | 50 | 60 | 0.80 |
| 55DC-901-441-XX | 900 | 440 | 90 | 120 | 1.8 | 60 | 60 | 1.00 |
| 55DC-901-561-XX | 900 | 560 | 90 | 145 | 2.1 | 60 | 60 | 1.10 |
| 55DC-901-681-XX | 900 | 680 | 90 | 170 | 2.5 | 80 | 60 | 1.30 |
| 55DC-112-221-XX | 1100 | 220 | 90 | 97 | 2.5 | 50 | 60 | 0.90 |
| 55DC-112-281-XX | 1100 | 280 | 90 | 120 | 2.1 | 50 | 60 | 1.20 |
| 55DC-112-361-XX | 1100 | 360 | 90 | 145 | 1.9 | 60 | 60 | 1.30 |
| 55DC-112-421-XX | 1100 | 420 | 90 | 170 | 2.3 | 80 | 60 | 1.30 |
| 55DC-132-161-XX | 1300 | 160 | 90 | 97 | 2.1 | 50 | 60 | 0.80 |
| 55DC-132-211-XX | 1300 | 210 | 90 | 120 | 1.9 | 50 | 60 | 1.00 |
| 55DC-132-251-XX | 1300 | 250 | 90 | 145 | 2.5 | 60 | 50 | 1.20 |
| 55DC-132-321-XX | 1300 | 320 | 90 | 170 | 2.8 | 80 | 53 | 1.30 |



Dimensions

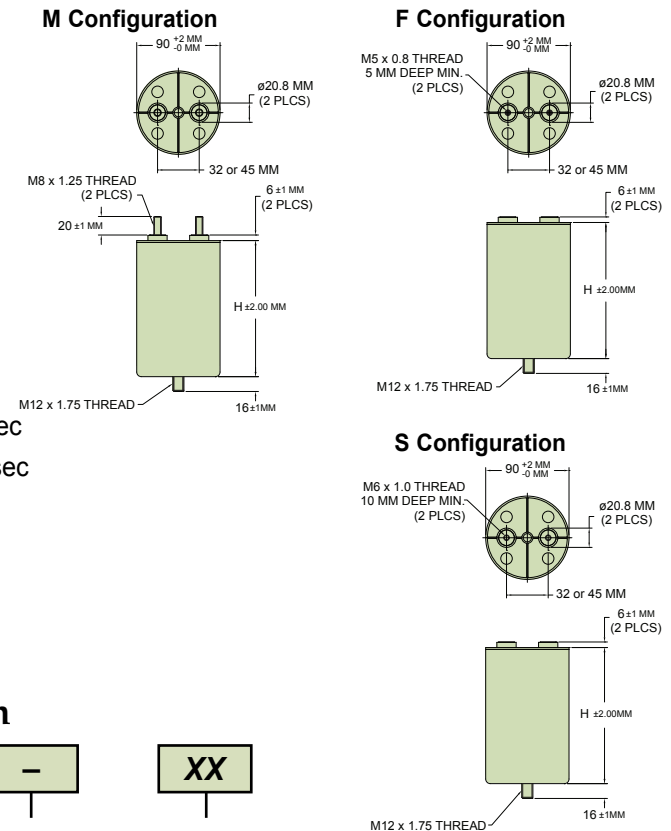

Audio Film Capacitors

Features

- Multiple dielectric options
- Metalized film and film/foil construction
- Wrap and fill, encapsulated and hermetic options
- Multiple lead configurations, tape and epoxy colors
- Ability to wind 2-10 layers in a single pass
- Ability to provide 4-12 micron film
- Wide range of sized up to 2.000" D x 4.250" L
- Custom designs available

Benefits

- Application matching for best performance and cost
- Consistent and repeatable, producing high quality components in smaller package size
- Improved productivity and increased voltage capability
- Excellent performance especially for audio applications
- Tighter tolerance to help meet critical application requirement for capacitance and voltage
- Hermetic option provides enhanced protection for use in harsh environments



| Capacitor Type | Operating Temperature | WVD C | WVAC | Capacitance Range | DF | Insulation Resistance | TC | DA | Key Features |
|----------------------------------|-----------------------|-----------|----------------------------|-------------------|------------|--|------------|-------|--|
| Metallized Film Polyester | -55 to +85°C | 50 - 600 | N/A | 0.001 - 15 µF | 1.0% | 10 - 25 kMΩ • µF or 40 - 60 kMΩ, w/e less | -6 to +15% | 0.6% | Low cost |
| Film - Foil Polyester | -55 to +85°C | 100 - 600 | N/A | 0.001 - 5 µF | 0.5% | 50 kMΩ • µF or 100 kMΩ, w/e less | -6 to +15% | 0.6% | Low cost |
| Metallized Polypropylene | -55 to +85°C | 200 - 600 | 504 @ 60 Hz 115 @ 1 kHz | 0.001 - 8 µF | 0.2% | 200 kMΩ • µF or 400 kMΩ, w/e less | -4 to +2% | 0.1% | Low DF |
| Film-Foil Polypropylene | -55 to +85°C | 100 - 600 | AC Capable | 0.001 - 1 µF | 0.1% | 250 kMΩ • µF or 500 kMΩ, w/e less | -4 to +2% | 0.1% | Low DF |
| Metallized Polyphenylene Sulfide | -55 to +125°C | 50 - 600 | 240 @ 60 Hz 160 @ 1 kHz | 0.001 - 10 µF | 0.3 - 0.5% | 25 - 50 kMΩ • µF or 50 - 100 kMΩ, w/e less | ±2% | 0.2% | High temp capability No voltage derating |
| Metallized Polycarbonate* | -55 to +125°C | 50 - 600 | 240 @ 60 Hz 160 @ 1 kHz | 0.001 - 10 µF | 0.3 - 0.5% | 25 - 50 kMΩ • µF or 50 - 100 kMΩ, w/e less | ±2% | 0.2% | High temp capability No voltage derating |
| Metallized Teflon | -55 to +170°C | 50 - 5000 | AC Capable | 0.0047 - 10 µF | 0.1% | 100 kMΩ • µF or 200 kMΩ, w/e less | -6 to +15% | 0.06% | High temp capability Electrical characteristics |

* Metallized Polycarbonate is being phased out and replaced by Metallized Polyphenylene Sulfide

magnetics



Magnetics

we offer a variety of transformers, inductors, choke, coils and custom solutions to meet your magnetics needs



Custom Magnetic Solutions

We offer extensive design and manufacturing capabilities, including more than two dozen magnetic core materials and winding wire from 6 to 45 gauge with many coatings, leads and terminations. We produce toroids ranging in size from 0.5" to 18" in diameter with up to 4,000 turns and accuracy to +/- 1 turn, and a wide variety of encapsulation and laminate options. Below are some of the critical design criteria we will work with your engineering team to address.

Electrical Characteristics - Identifying the circuit function/application and/or specifying electrical requirements such as amperage, voltage, inductance, frequency response, leakage, and noise reduction often determines selection of materials and components.

Mechanical Constraints - Restrictions on maximum height and available board area and mounting style (surface mount or through-hole) set physical parameters that often are difficult to change. Mechanical size restrictions can strongly affect component temperature rise.

Environmental Conditions - Maximum/minimum operating temperatures and allowed surface and/or internal temperatures of components, including UL compliance, as well as conditions such as air flow, sealing of container, high shock, and vibration will influence material selection and design.

Regulating Requirements - Considerations include safety standards to be met (eg. IEC/UL 60950-1, UL61010-1, UL 1585 etc), listing of the unit with a regulatory agency such as UL, CSA or VDE and requirements for UL thermal insulation system marking.

Qualification Conditions - Identify the qualification process required prior to approval, be it customer standards, or Hi-Rel standards such as MIL-PRF-27 or MIL-STD-981 and whether formal testing or the ability to demonstrate compliance by design is necessary.

Our magnetics group combines the people, products and technologies of several brands, including Filtran and RTI Electronics, in order to satisfy your magnetics requirements. API Technologies is a key supplier to many of the world's leading OEMs, serving the military, aerospace, medical, telecom, transport, RF and industrial/test measurement markets.

Quality Construction

API's commitment to quality begins with a rigorous raw material selection and inspection process and continues through highly trained operators utilizing state-of-the-art equipment. The end result are the highest quality magnetics consistently manufactured to meet some of the industry's most stringent requirements including many MIL, ANSI and ISO certifications.

Magnetics

Current Transformers

Current Sensors

- Measures electrical current (AC & DC) and can transform current from high to low measurable values
- Wide primary current range of 3.5 Amps to 800 Amps
- Apps include advanced fault tolerant computers and workstations, control panels reading current flowing to electric transformer, telecom and communications

High Frequency Current Transformers

- 20 kHz-100 kHz operating frequency
- Available totally encapsulated, with or without wound primary turns and loading resistor
- Built to UL, MIL, VDE, CE specs, EMRL current transformers meet UL1244
- Ideal for ammeters, wattmeters, relays and cross current compensation

Power Inductors/Chokes

- Precision wound heavy-duty toroidal inductors
- Stores energy as a magnetic field, can delay and reshape alternating current
- Up to 100 amps, standard
- Semi or full epoxy molded, horizontal and vertical mounting
- Lighting dimmers – low wattage residential to higher wattage commercial, motor controls, SCR controls and line filters

Switch Mode Power Supply Inductors

- Filter inductors, toroidal current sense transformers and high frequency inverter transformers
- Performance verified in 25kHz power supply
- 10 to 1,000 watts with low power losses
- Switching frequencies from 5 to 100 kHz
- Open winding, semi-encapsulated and encapsulated construction
- Custom designs up to 200 Amps

Lighting Chokes & Inductor/Filters

- Precision wound heavy-duty toroidal inductors
- Rugged design
- 120 volt models from 12.5 to 100 Amps
- 240 volt models from 8.3 to 60 Amps
- High quality noise rejection filter
- Ideal for lighting dimmers, EMI/RFI filters, PWM and PM circuits primarily for motor controls, UPS Systems, differential mode line filters



Load Detector Current Sensors

- Innovative Snap-On load detectors mount on pre-wired systems without disrupting existing connections
- Broad frequency response of 30Hz to 15 kHz
- Measure currents up to 40 Amps RMS continuous and 120 Amps intermittent
- Excellent for economical energy management and automation control



Magnetics

Toroidal Power Transformers

- 50/60HZ, 5-15,000V Power Transformers (Europe ER series)
- 60 Hz 120V Power Transformers (U.S. FR series)
- 400Hz 115-230V Power transformer (Military DR series)
- Convert power-level voltages from one level or phase configuration
- Lower magnetic leakage, lower electrical noise and mechanical hum
- Excellent as isolation step-down and high voltage step-up transformers, autotransformer, ferroresonant transformer and smoothing inductor

Laminate Power Transformers

- Value ranges from 3 VA to 100,000 VA
- Transform line voltage to any other voltage
- Apps include audio power conditioning, low-wattage indoor and outdoor lighting solutions, military and commercial UPS systems, power supplies, mono crystalline and crystalline solar processing

Modem & Module Transformers

- Broadband and voiceband transformers used for datacom and telecom applications
- xDSL, T1/E1, T3/DS3/E3/STS-1, ISDN interface modules
- ADSL / POTS splitter modules
- Impedance and line matching transformers

Air Coils

- Custom and build-to-print air coils for RF power, filter and sensing applications
- Made with specialized custom tooling to meet customer dimensional and electrical requirements

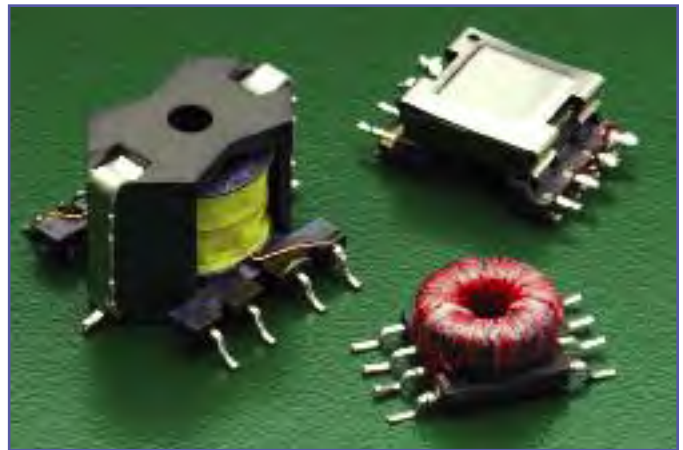

- EMI Filters
- Filtered Interconnects
- Ceramic Capacitors
- Specialty Connectors
- Power Filters & Capacitors
- Magnetics

Sales Offices

NORTH AMERICA

8061 Avonia Road
Fairview, Pennsylvania 16415
Phone: 814-474-1571
Fax: 814-474-3110

EUROPE

Spectrum Control GmbH
Hansastraße 6
91126 Schwabach, Germany
Phone: (49)-9122-795-0
Fax: (49)-9122-795-58

CHINA

Spectrum Control Limited
2nd Industrial Area
Ling Tou Industrial Road
Qiad Tou Town, Dong Guan City
Guang Dong Province 523530
Peoples Republic of China
Phone: (011)-86-769-8343-7761
Fax: (011)-86-769-8343-7760

ISO 9001:2000

AS 9100

RoHS
COMPLIANT



About API Technologies

API Technologies Corp. is a trusted provider of RF/microwave, microelectronics, and security solutions for critical and high-reliability applications. The company designs, develops and manufactures electronic components, modules, systems and products for technically demanding defense, commercial/industrial and aerospace applications. API Technologies' customers include many leading Fortune 500 companies, as well as a majority of NATO governments. While API was founded in 1981, our heritage brands have served the demanding, hi-rel marketplace for more than 60 years. API Technologies trades on the NASDAQ under the symbol ATNY.

Power & Systems Solutions

Sensors Solutions

RF/Microwave & Microelectronics

Electromagnetic Integrated Solutions

Electronics Manufacturing Services

Secure Systems & Information Assurance

+1 855.294.3800
www.apitech.com