

# PROTECTING RECHARGEABLE LI-ION AND LI-POLYMER BATTERIES

in Consumer Portable Electronics

---

Littelfuse offers designers many different protection devices to choose from in an array of form factors and device characteristics that meet the needs of their particular design.

# PROTECTING RECHARGEABLE LI-ION AND LI-POLYMER BATTERIES

## in Consumer Portable Electronics

---

As sleeker designs and thinner portable consumer electronics, such as smart phones, tablets and other advanced handheld electronics, become increasingly popular, Lithium-ion and Lithium-Polymer batteries, known collectively as Li-batteries, have become the “go-to” power sources of choice in these applications. As battery technology and form factors for consumer devices expand beyond traditional cylindrical cells, Li-batteries are in increasing demand due to their high energy density, small form factors and design flexibility. These batteries, in turn, require ever-smaller circuit protection devices to help provide robust protection in thinner, lower-profile and more compact portable products.

### Need for Battery Protection

Li-battery packs are particularly sensitive to faults caused by external shorts, runaway charging conditions and abusive overcharging that can result in potentially damaging overcurrent and overtemperature conditions. The overcharge, deep-discharge, or short circuit conditions that create heat can cause a Li-battery cell to bloat, rupture, or experience other issues.

Although internal cell failures are less common, an adverse event may affect any of the complex electronics on the battery pack’s PCM (Protection Control Module), such as the fuel gauge or charge controller. Because these components are vulnerable to these events, Li-cells using PCMs require many levels of protection against overcharge shutdown, over-discharge shutdown, overtemperature shutdown, and overvoltage/undervoltage lockout of a cell that may lead to thermal runaway and possibly failure.

Organizations such as UL, IEC and IEEE have enforced safety regulations and established test requirements for Li-ion and Li-Polymer packs to demonstrate their resilience to both short circuit and overcharge events. (For additional details refer to UL2054, “Standard for Household and Commercial Batteries”; IEEE 1725-2006 “Standard for Rechargeable

Batteries in Cellular Telephones”; and IEC/EN 60950 and IEC 62133 specifications.). Moreover, certain end product applications require that the power output of a battery be limited to reduce the risk of device failures. The Limited Power Source (LPS) Test described in UL2054 is used to determine whether a cell or battery is suitable in such applications where safety issues may otherwise exist.

This application note discusses the need for protecting Li-batteries against short circuit conditions and shows how devices from Littelfuse’s business unit, Littelfuse, can help designers achieve robust and safe battery solutions. As a pioneer of polymeric positive temperature coefficient (PPTC) resettable devices, Littelfuse has developed several material platforms for protecting battery applications. Each offers different performance characteristics and a range of thermal cut-off, or activation, temperatures PolySwitch PPTC resettable devices offer form factors including strap, disc, surface-mount and weldable/reflowable products. The company’s MHP (metal hybrid PPTC) technology offers a resettable compact device for high-rate-discharge Li-Polymer and prismatic cell applications. Littelfuse also offers non-resettable chip fuses in sizes ranging from 0402 to 1206.

## Short Circuit Conditions

An unprotected battery cell or pack can deliver a very high current when it is “hard shorted” by a low-resistance element. In this case, power dissipated in the battery cell’s internal impedance can lead to a rise in cell temperature. The severity will depend on the pack’s thermal characteristics and the battery cell chemistry. Additionally, accidental short circuits can occur when a metal object, such as a keychain, bridges the exposed terminals of the battery cell/pack. These short circuits can increase temperatures to levels high enough to damage the cell, other components or surrounding materials. At a minimum, pack performance can deteriorate and, with some packs, thermal runaway may occur, and can result in damage. If an unprotected pack is “soft shorted” by an element with even a small amount of resistance, (e.g., a few hundred milliohms), the potential problem changes from being power dissipated in the cell to power being dissipated in the shorting element. Tests have shown that the resistive shorting element can reach temperatures in excess of 600°C during this type of event, which may result in ignition of adjacent combustible materials.

## Overcharge Conditions

Individual battery chemistries require specific charging profiles to optimize performance and minimize safety issues. If this profile is not met, an overcharge condition may occur. A battery pack overcharge condition is most often caused by:

- A runaway charging condition in which the charger fails to stop supplying current to the pack once it is fully charged. This is typically caused by a charger fault.
- Abusive charging that occurs when the pack is charged under the wrong conditions by an incorrect or faulty charger. The most likely cause of this condition occurs when a consumer uses an aftermarket or non-compatible charger. Product reliability or safety issues may arise when using some aftermarket products due to the proprietary nature of cell chemistries and charger designs.

Battery cell overcharge can result from an overcurrent or overvoltage condition or a combination of both. If current or voltage is allowed to exceed prescribed values, a significant rise in cell temperature may result. During a typical overcharge fault, the cell temperature rises when excessive voltage across the fully charged cell causes chemical degradation of the cell components.

## PolySwitch PPTC Resettable Devices vs. Traditional Solutions

During a short circuit fault, Littelfuse’s PolySwitch PPTC resettable device rapidly heats up due to the excess current. As it nears trip temperature, the device increases in resistance by several orders of magnitude and limits the fault current to a low level. When the fault condition is removed and the power is cycled, the device cools and returns to a low-resistance state. If the fault is not cleared and the power is not cycled, the device will remain latched in the high-resistance state. During a typical overcharge fault, cell temperature rises when excessive voltage across the fully charged cell causes chemical degradation of cell components.

When a PolySwitch PPTC device is included in a circuit, as the cell temperature rises, the temperature of the PolySwitch device increases accordingly and less current is required to trip the device. PolySwitch PPTC devices are often used to replace bimetal or thermal fuse protectors since traditional bimetals often result in bulky, high-cost protection solutions. Bimetals normally do not latch in the protected position during a fault condition, which may result in battery pack fault and battery cell damage.

Unlike resettable PolySwitch PPTC devices, one-shot secondary overcurrent protectors, such as thermal fuses, are difficult to set at the low temperatures required for charge protection and may trip at high ambient temperatures. Since they do not reset, they can cause an otherwise functional pack to be disabled, which can result in unnecessary field returns.

Low-temperature PolySwitch PPTC devices help provide overtemperature protection in addition to overcurrent protection. The device’s resettable functionality provides that nuisance tripping caused by exposure to high storage temperatures, such as leaving a cell phone inside a vehicle on a hot day, does not permanently disable the pack.

## PolySwitch Devices for Li-Battery Protection

Li-packs typically include ICs capable of detecting and implementing an overvoltage lockout, undervoltage lockout, overtemperature protection and overcurrent protection. ICs and MOSFETs are often used as the primary pack protection in conjunction with a fuel gauge device to track the battery cell capacity, state-of-charge (%), run-time to empty (minutes), battery voltage (mV) and temperature.

# Protecting Rechargeable Li-Ion and Li-Polymer Batteries

A PolySwitch PPTC device placed in series with the battery helps provide a second level of protection in the event of a control circuit malfunctioning (Figure 1). Although the semiconductor circuitry is considered reliable, there are conditions under which failure of the primary protection may occur, including excessive electrostatic discharge, high temperature or oscillation during a short circuit condition. In these cases, the PolySwitch PPTC device helps provide cell overtemperature protection on charge and discharge, as well as redundant overcurrent protection. When a PolySwitch PPTC device is included in the circuit, the temperature of the device increases accordingly as the cell temperature rises and less current is required to trip the device.

A wide selection of PolySwitch PPTC products is offered for Li-battery protection. The PolySwitch family includes devices offering a range of thermal cutoff (activation temperatures) from 85°C to 125°C. The PolySwitch PPTC device's low resistance helps meet the battery pack's resistance budget requirements, and its low trip temperature helps provide protection against thermal runaway in case of an abusive overcharge. PolySwitch PPTC resettable devices are also available in a variety of form factors and current ratings.

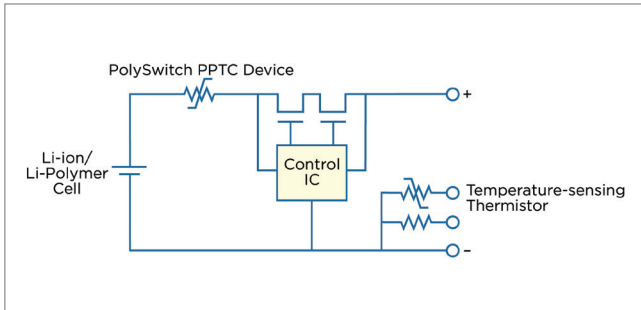

Figure 1. PolySwitch PPTC device in a typical protection circuit for a Li-ion or Li-Polymer cell.

## PolySwitch Strap Products: Installation Method – Spot Weld

PolySwitch strap products offered by Littelfuse include the SRP, LR4, VTP, VLR, VLP, MGP and MXP families. Strap devices, which come in a flat, tab-like form factor, can be incorporated into cylindrical based packs, prismatic cells or even pouch packs and can be applied to specific battery chemistries or usage profiles. Their installation method is to be spot welded to cells or straps in the battery pack (Figure 2).

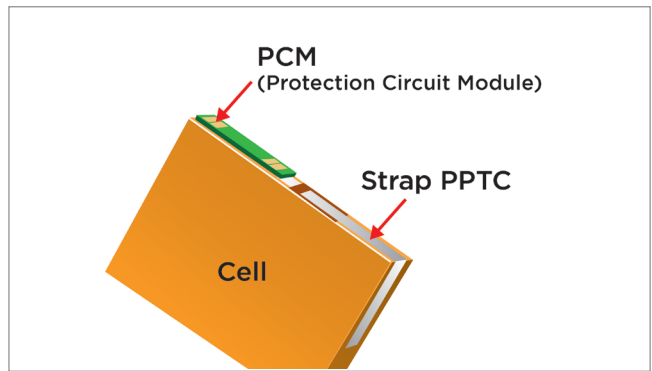

Figure 2. PolySwitch strap devices offer space-saving solution for protecting battery cells.

The evolution of Littelfuse's strap devices has progressed to lower resistance, smaller form factors and increased thermal protection, as shown in Figures 3 and 4.

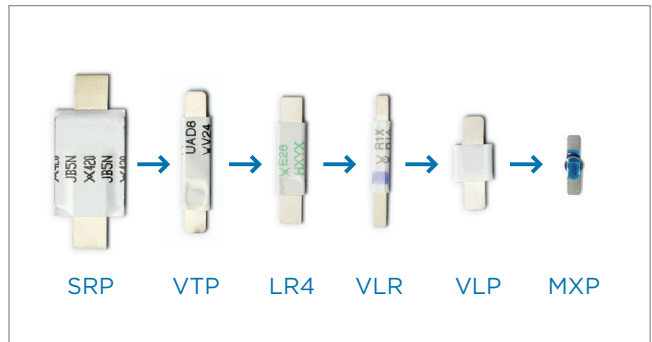

Figure 3. A wide range of PolySwitch strap devices are available for specific pack requirements.

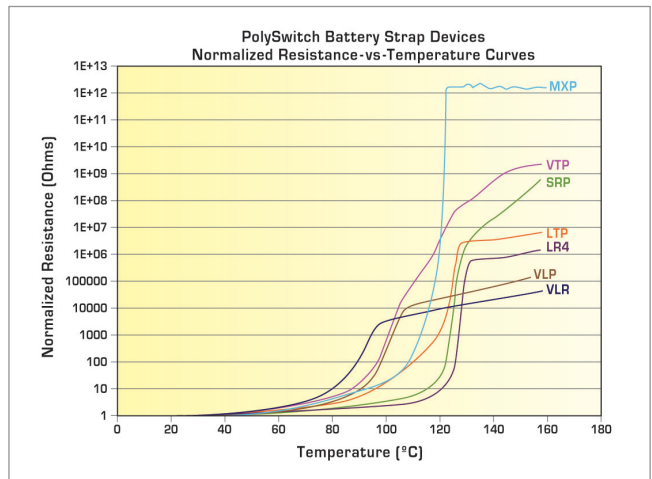

Figure 4. PolySwitch strap device enables current to be interrupted at different ambient temperatures.

# Protecting Rechargeable Li-Ion and Li-Polymer Batteries

The PolySwitch low-resistance (low rho) MXP strap device, shown in Figure 5, incorporates conductive metal particles to achieve lower resistance than traditional carbon black-filled PPTC devices. The MXP device is 88% smaller than the prior-generation VTP strap device (Figure 6), while also providing approximately the same hold current at 60°C. Regardless of the pack chemistry, device hold current is selected on the basis of the maximum average charge or discharge current and takes into account the maximum operating temperature. The form factor will depend on the available space within the pack. PolySwitch PPTC strap devices with activation temperatures (thermal cutoff) from 85°C to 125°C are offered in a wide range of custom and standard configurations.

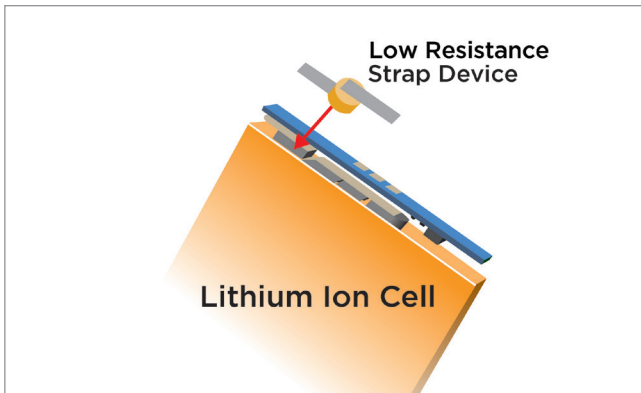

Figure 5. The low rho MXP strap device and surface-mount device are placed under the PCB. (The MXP Strap length and configuration can also be customized per customer requirements.)

## PolySwitch Surface-Mount Products: Installation Method – Reflow Solder

PolySwitch surface-mount products are well suited for battery PCMs since their smaller size helps save board space and eases design complexity. The nano, micro, and miniSMDxxxx and the new nano, micro, and miniSMDxxxLR (low resistance) devices, for example, offer low profiles and small form factors that can be reflow soldered. While many surface-mount PPTC devices are already low resistance, the lower resistance of the miniSMDxxxLR devices help maintain the system impedance budget.

## PolySwitch L-Tab Devices: Installation Methods – Reflow Solder and Spot Weld

The PolySwitch L-Tab device helps provide a weldable and reflowable/solderable device. With operating currents up to of 4A at room temperature, they are suitable for use for battery protection in high-performance tablets. They also offer ultra-low resistance to help maintain the system impedance budget. Locating protection circuitry in close proximity to the cell helps eliminate the need for long metal interconnects and helps improve thermal sensing (Figure 7).

The L-Tab device can be soldered onto the battery PCM and the device's L-shaped tab/terminal can be directly welded to the battery cell tab, therefore providing cost savings. Additionally, its “L” shape assists in reducing manufacturing steps when the PCM is folded into the pack.

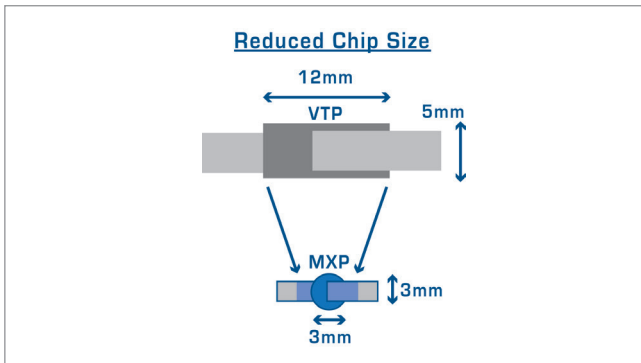

Figure 6. Compared to the prior-generation VTP device, the PolySwitch MXP device has lower resistance in a smaller form factor.

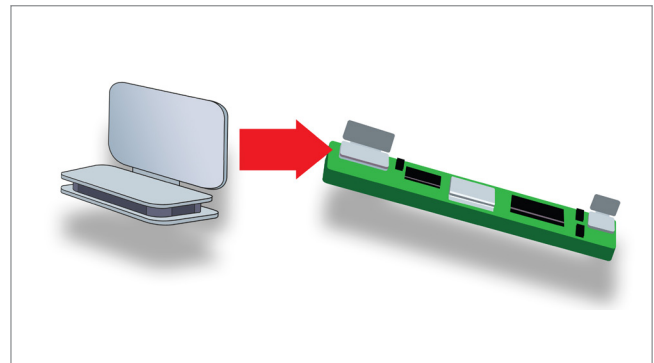

Figure 7. PPTC L-Tab devices occupy the same space as the existing battery terminal block.

### PolySwitch Disc Products: Installation Method – Press Fit

A PolySwitch disc device is a bare disc made of PPTC material that is placed in a Lithium-ion 18650 cylindrical cell header to help protect cells during shipping and handling prior to assembly in packs (Figure 8). The disc device also helps provide protection for cells that are sold individually as AA and AAA-sized, non-rechargeable lithium batteries for consumer use. Each disc device is custom designed for the cell it will be used with.



Figure 8. A PolySwitch disc device's placement on an 18650 battery cell.

### MHP-TA Devices: Installation method – Spot Weld

The MHP-TA devices offer a space-saving solution for protecting higher energy Lithium-polymer and prismatic battery pack applications such as ultra-thin notebooks and tablets. These resettable thermal cut-off (TCO) devices consist of a PolySwitch PPTC device in parallel with a bimetallic protector. They activate thermally at temperatures from 72°C to 90°C, while also offering a high withstand voltage and high hold current. Available in an ultra-low-profile (L: 5.8mm x W: 3.85mm x H: 1.15mm) package (Figure 9), their benefits include their extremely low resistance, ability to open thermally, ability to help provide latched protection and their resettability. The MHP-TA device eliminates the non-latching properties of traditional bimetals because the built-in PPTC keeps the bimetal contacts latched open during a fault condition.

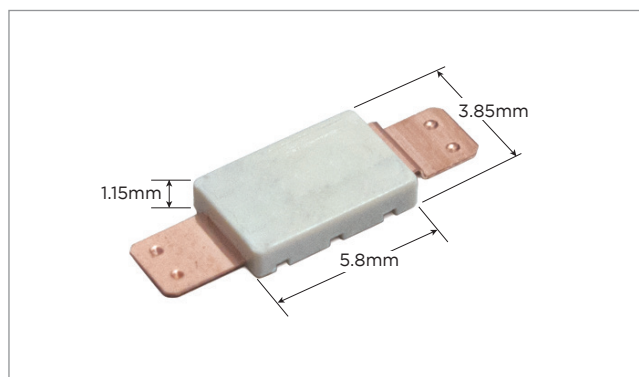

Figure 9. MHP-TA device targets thinner Li-battery cell applications such as ultra-thin notebooks.

### Surface-Mount Fuses: Installation Method – Reflow Solder

Littelfuse surface-mount chip fuses can be used for overcurrent protection in applications where non-resettable protection is desired. These devices are offered in surface-mount package sizes ranging from 0402 to 1206. Most safety standards limit the maximum fuse current rating to five amps. When a failure occurs that clears a fuse, the pack will be permanently disabled. Fuses, rather than resettable PolySwitch PPTC devices, are suitable for applications where a permanent shutdown is desired whenever an overcurrent fault occurs.

# Protecting Rechargeable Li-Ion and Li-Polymer Batteries

## Selecting Circuit Protection Devices

Table 1 shows a selection of Littelfuse PolySwitch devices that are suitable for Li-battery protection: PolySwitch PPTC devices (strap, surface-mount, disc, L-Tab), as well as the MHP-TA device and surface-mount fuses.

When adding protection devices, battery pack designers must decide what level of protection is required for each application. A system test should be used to determine whether or not a specific protection device is appropriate.

The protection requirement is cell chemistry-dependent and precise protection requirements should be obtained from the cell manufacturer. Recommendations from device manufacturers are useful in narrowing protection options and benchmarking other pack protection schemes may help provide a good lead for further investigation. However, specific testing of each protection option is the best way to evaluate its effectiveness.

| Battery Protection Device | Strap   | Surface-Mount  | MHP-TA          | L-Tab                                   | Fuse                      | Disc                                    |
|---------------------------|---|--|-----------------|---|---------------------------|---|
| Installation Method(s):   | Spot Weld   | Reflow Solder  | Spot Weld       | Reflow Solder, Spot Weld                | Reflow Solder             | Press-Fit                               |
| Product Family            | SRP, LR4, VTP, VLP, VLR<br><br><b>low rho</b><br>MGP, MXP | SMD, miniSMD, microSMD, nanoSMD, picoSMD, femtoSMD<br><br><b>low rho</b><br>miniSMDLR, microSMDLR, nanoSMDLR | MHP-TA, MHP-TAM | Contact Littelfuse for more information | O402SFx, O603SFx, 1206SFx | Contact Littelfuse for more information |

Table 1. Selection of Littelfuse PolySwitch products for battery applications.

## Summary

Battery applications designers must respond to the trend toward more space-efficient battery packs that require ever-smaller protection devices. Littelfuse PolySwitch offers them many different protection devices to choose from in an array of form factors and device characteristics that meet the needs of their particular design.

### Notice:

Information furnished is believed to be accurate and reliable. However, users should independently evaluate the suitability of and test each product selected for their own applications. Littelfuse products are not designed for, and shall not be used for, any purpose (including, without limitation, military, aerospace, medical, life-saving, life-sustaining or nuclear facility applications, devices intended for surgical implant into the body, or any other application in which the failure or lack of desired operation of the product may result in personal injury, death, or property damage) other than those expressly set forth in applicable Littelfuse product documentation. Warranties granted by Littelfuse shall be deemed void for products used for any purpose not expressly set forth in applicable Littelfuse documentation. Littelfuse shall not be liable for any claims or damages arising out of products used in applications not expressly intended by Littelfuse as set forth in applicable Littelfuse documentation. The sale and use of Littelfuse products is subject to Littelfuse Terms and Conditions of Sale, unless otherwise agreed by Littelfuse.