

Product Overview

PolyZen Protection Device for USB Applications

A unique feature of the PolyZen device is that the Zener diode is thermally coupled to a resistively non-linear, polymer PTC (Positive Temperature Coefficient) layer. This PTC layer is fully integrated into the device, and is electrically in series between V_{IN} and the diode clamped V_{OUT} .

PolyZen Protection Device for USB Applications

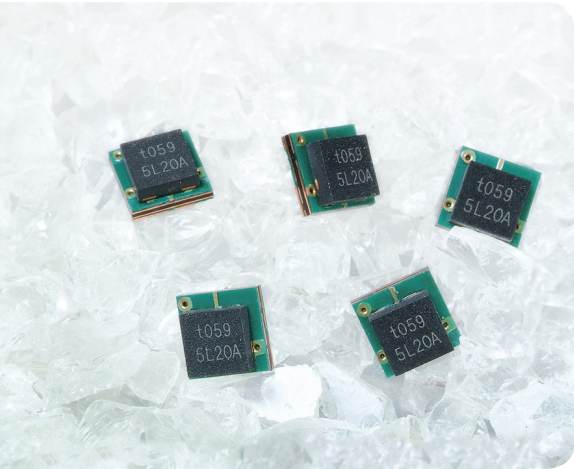

KEY FEATURES

- Meets USB suspend mode current requirement - 500QA (typ) @ 5.0V
- Overvoltage transient suppression
- Stable V_z vs fault current
- Time delayed, overvoltage trip
- Time delayed, reverse bias trip
- Multi-Watt power handling capability
- Integrated device construction
- RoHS compliant and halogen free

Littelfuse PolyZen devices are polymer-enhanced, precision Zener diodes. They offer resettable protection against multi-Watt fault events and spare the need for large heavy heat sinks.

A unique feature of the PolyZen device is that the Zener diode is thermally coupled to a resistively non-linear, polymer PTC (Positive Temperature Coefficient) layer. This PTC layer is fully integrated into the device, and is electrically in series between V_{IN} and the diode clamped V_{OUT} .

This polymer PTC layer responds to either extended diode heating or overcurrent events by transitioning from a low to high resistance state, also known as “tripping”. A tripped PTC will limit current and generate voltage drop. It helps to protect both the Zener diode and the follow-on electronics and effectively increases the diode’s power handling capability.

The Zener diode used for voltage clamping in the PolyZen device was selected due to its relatively flat voltage vs current response. This helps improve output voltage clamping, even when input voltage is high and diode current is large.

The polymer-enhanced Zener diode helps protect sensitive portable electronics from damage caused by inductive voltage spikes, voltage transients, improper power supplies, and reverse bias conditions. The PolyZen ZEN059V130A24LS device is particularly useful for USB 2.0/3.0 powered devices; typically, it draws only 500QA of operating current in USB suspend mode.

APPLICATIONS

- USB 2.0/3.0 powered consumer electronics, external hard disk drives and solid state devices
- DC power port protection in systems using barrel jacks for power input
- DC power port protection in portable electronics and navigation devices
- DC output voltage regulation
- USB 3.0 hubs and adapter cards
- Laptops and desktop PCs

BENEFITS

- Stable Zener diode helps shield downstream electronics from overvoltage and reverse bias
- PTC trip events help to protect the Zener diode and extend its power handling capability
- Analog nature of trip events minimizes upstream inductive spikes
- Minimal power dissipation requirements
- Single component placement

PolyZen Protection Device for USB Applications

TYPICAL USB 2.0/3.0 APPLICATION BLOCK DIAGRAM

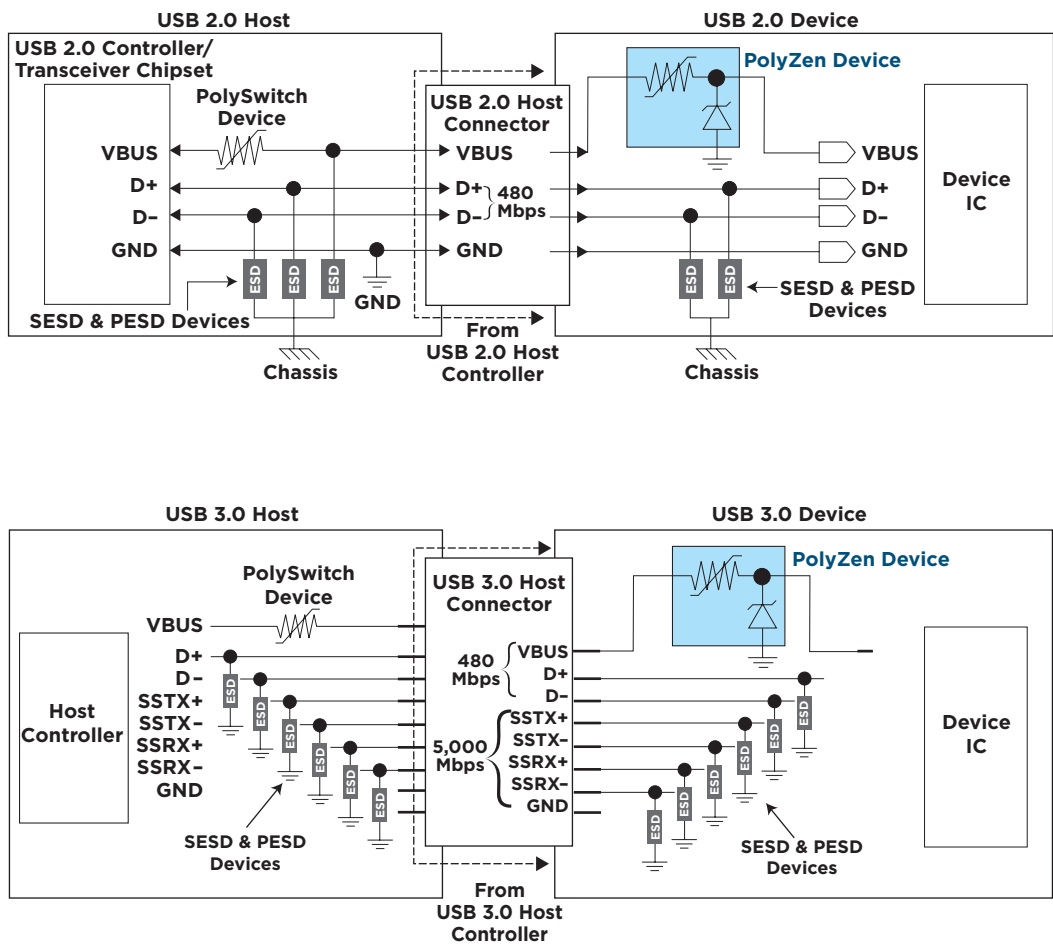

ELECTRICAL CHARACTERISTICS FOR ZEN059V130A24LS

$V_z^{(1)}$ (V)			$I_{z1}^{(1)}$ (A)	$I_{HOLD} @ 20^\circ C$ (A)	Operating ⁽²⁾ Current		R_{Typ} (Ω)	R_{1Max} (Ω)	$V_{INT MAX}$ (V)		$I_{FLT MAX}$		Tripped Power Dissipation Max	
Min.	Typ.	Max.			Test Voltage	Max Current (mA)			$V_{INT MAX}$ (V)	Test Current (A)	$I_{FLT MAX}$ (A)	Test Voltage (V)	Value (W)	Test Voltage (V)
5.8	5.9	6.0	0.1	1.3	5.0	0.65	0.12	0.15	24	3	+6 -40	+24 -16	1.0	24

(1) I_{z1} is the current at which V_z is measured.

(2) Typical operating current is 500QA @ 5.0V which meets USB suspend mode requirement.

PolyZen Protection Device for USB Applications

TYPICAL CHARACTERISTIC

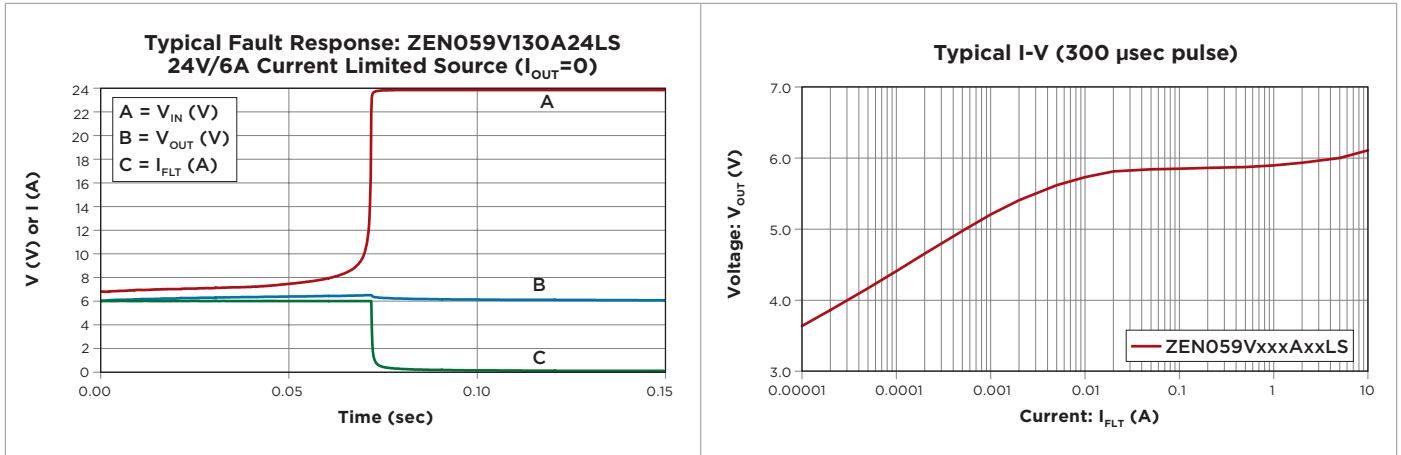

Pin Description

Pin Number	Pin Name	Pin Function
1	V_{IN}	V_{IN} = Protected input to Zener diode
2	GND	GND = Ground
3	V_{OUT}	V_{OUT} = Zener regulated voltage output

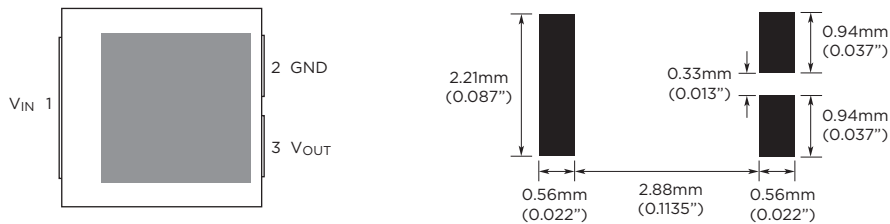

PolyZen Protection Device for USB Applications

Pin Number	Pin Name	Min	Typical	Max
Length	L	3.85 mm (0.152")	4 mm (0.16")	4.15 mm (0.163")
Width	W	3.85 mm (0.152")	4 mm (0.16")	4.15 mm (0.163")
Height	H	1.4mm (0.055")	1.7 mm (0.067")	2.0 mm (0.081")
Length Diode	Ld	-	3.0 mm (0.118")	-
Height Diode	Hd	-	1.0 mm (0.039")	-
Offset	O1	-	0.6 mm (0.024")	-
Offset	O2	-	0.7 mm (0.028")	-

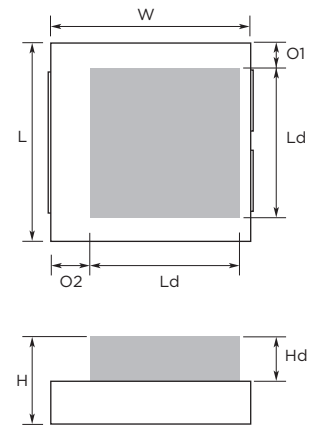

Notice:

Information furnished is believed to be accurate and reliable. However, users should independently evaluate the suitability of and test each product selected for their own applications. Littelfuse products are not designed for, and shall not be used for, any purpose (including, without limitation, military, aerospace, medical, life-saving, life-sustaining or nuclear facility applications, devices intended for surgical implant into the body, or any other application in which the failure or lack of desired operation of the product may result in personal injury, death, or property damage) other than those expressly set forth in applicable Littelfuse product documentation. Warranties granted by Littelfuse shall be deemed void for products used for any purpose not expressly set forth in applicable Littelfuse documentation. Littelfuse shall not be liable for any claims or damages arising out of products used in applications not expressly intended by Littelfuse as set forth in applicable Littelfuse documentation. The sale and use of Littelfuse products is subject to Littelfuse Terms and Conditions of Sale, unless otherwise agreed by Littelfuse.