

A.SCOPE 範疇

This specification applies magnetic buzzer.KLJ-9025-3627

此規格書適用於贴片電磁式蜂鳴器. KLJ-9025-3627

B.SPECIFICATION 规格

NO.	Item	Unit	Specification	Condition
1	Rated Voltage 額定電壓	Vo-p	3.6	
2	Operating Volt 操作電壓	Vo-p	2.5~4.5	
3	Mean Current 平均耗電流	mA	Max. 100	Applying rated voltage. 2731HZ squar wave. 1/2duty 施以額定電壓.2731HZ.方波.50%負載
4	Coil Resistance 直流阻抗	Ω	16 \pm 3	
5	Sound Output 輸出音壓	dBa	Min.85	Distance at 10cm (A-weight). Applying rated voltage 2731HZ.square wave.1/2duty 在 10cm 處, 施以額定電壓。2731HZ.方波.50% 負載
6	Rated Frequency 額定頻率	HZ	2731	
7	Operating Temp 操作溫度	$^{\circ}$ C	-30 ~+70	
8	Storage Temp 儲存溫度	$^{\circ}$ C	-40 ~+80	
9	Dimension 尺寸	mm	L9.0×W9.0×H2.5	See attached drawing. 請參照外觀尺寸圖
10	Weight 重量	gram	0.6	
11	Material 材質		L.C.P (Black)	
12	Terminal 端子		SMD type (鍍全錫/Plating Sn)	See attached drawing. 請參照外觀尺寸圖
13	Environmental Protection Regulation 環保法規		RoHS	
14	Storage life 保存期限	month	6	6 months preservation at room temp.(25 \pm 3 $^{\circ}$ C). Humidity30% 在室溫下 25 \pm 3 $^{\circ}$ C. 湿度 30%以下可保存 6 個月

C.TYPICAL FREQUENCY RESPONSE CURVE 頻率響應曲線

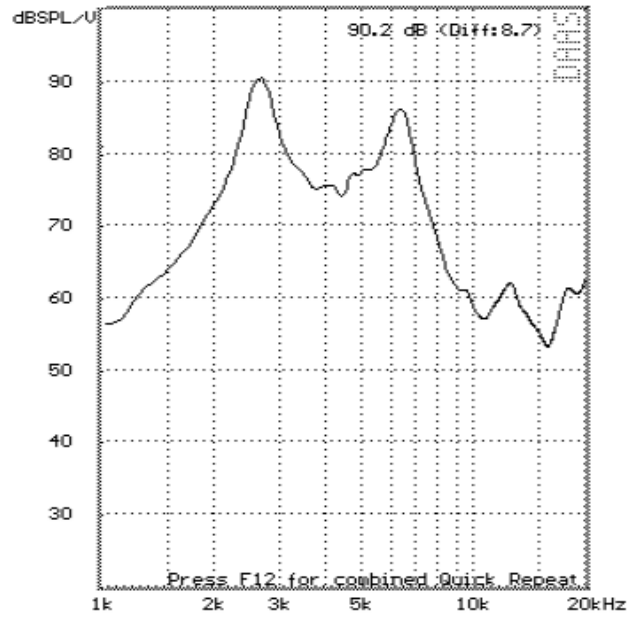

D.APPEARANCE DRAWING 外觀尺寸图

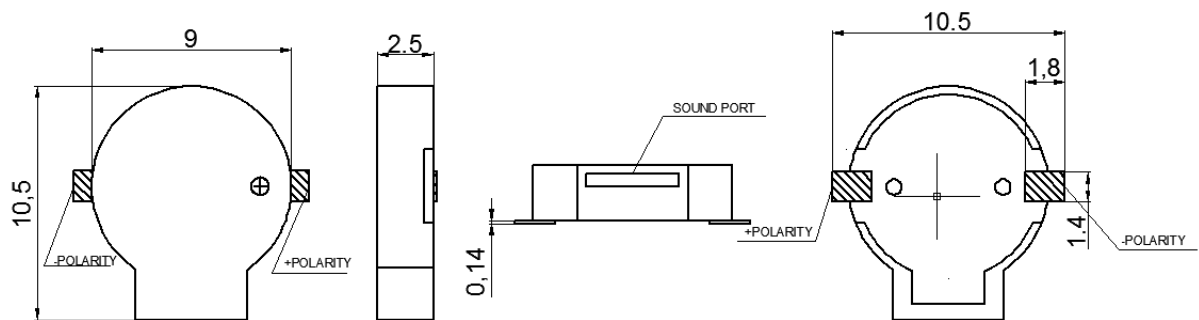

Tol:±0.3

Unit:mm

G.MECHANICAL CHARACTERISTICS 機械特性

NO.	Item	Test condition	Evaluation standard
1	Solderability 焊錫附著性	Lead terminals are immersed in solder bath of +260±5°C for 3±1 Second. 端子置於錫膏內. 錫膏溫度: +260±5°C. 焊接時間: 3±1 秒	95% surface of lead pads must be covered with fresh solder 錫膏需覆蓋端子上方 95%
2	Soldering Heat Resistance 焊錫耐熱性	The product is followed the reflow temperature curve to test its reflow thermostability 產品依照迴焊溫度曲線測試迴焊耐熱性	No interference in operation 操作上无任何不良
3	Terminal Mechanical Strength 端子強度	Lead pads shall be soldered on the pc board.and the force 9.8N (1.0kg) shall be applied behind the part for 10 seconds 將端子焊在 PC 板上后, 對單體施以 9.8N (1.0kg) 拉力 10 秒	No damage and cutting of 端子不鬆動, 不脫落
4	Vibration 震動測試	Buzzer shall be measured after being applied vibration of amplitude of 1.5mm with 10 to 55hz band of vibration frequency to each of 3per-pendicular directions for 6 hours 震動週波數 10~55HZ.全振幅 1.5mm 于 X.Y.Z 3 個方向.各 6 小時	After the test the part shall meet specifications With-out any damage in appearance and the SPL Should be in±10dBA compared with initial one 經測試后, 单体除音壓外外觀及电气特性須符合規格, 輸出音壓变化量須±10dBA 內
5	Drop test 落下測試	The part only shall be dropped from a height of 75cm onto a 40mm thick wooden board 3 times in 3 axes(X.Y.Z).(a total of 9 times). 單體從 75 公分高處.X.Y.Z. 3 個方向.各 3 回.落于 40mm 厚木板上.	

H.ENVIRONMENT TEST 環境測試

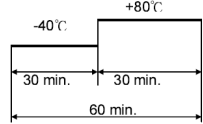
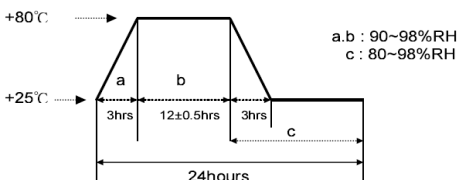
NO.	Item	Test condition	Evaluation standard
1	High temp test 高溫測試	After being placed in a chamber at +80°C for 48 hours. 置于+80°C環境中 48 小時	After the test the part shall meet specifications with-out any degradation in appearance and performance except SPL. After 4 hours at +25°C. the SPL should be in±10dBA compared with initial one 經測試后, 靜置于+25°C (室溫) 環境中 4 小時, 单体除音壓外, 外觀及电气特性須符合規格, 輸出音壓变化量需在±10dBA 內
2	Low temp test 低溫測試	After being placed in a chamber at -40°C for 48 hours. 置于-40°C環境中 48 小時	
3	Therman Shock 熱衝擊實驗	The part shall be subjected to 10 cycles.One cycle shall consist of: 對单体施以熱衝擊實驗 10 次循環.其循環內容如圖示 	
4	Temp./Humidity Cycle 溫度/濕度循環測試	The part shall be subjected to 10 cycles. One cycle shall be 24 hours and consist of 单体承受溫度/濕度循環測試 10 次.其循環內容如圖示 	

I.RELIABILITY TEST 信赖性测试

No.	Item	Test condition	Evaluation standard
1	Operating life test 寿命测试	1. Ordinary temperature 室温寿命测试 The part shall be subjected to 100 hours at room temperature with 3.0V.4000HZ applied (+25±10℃) 下, 输入 3.0V. 4000HZ 连续操作 100 小时 2. High temperature 高温寿命测试 The part shall be subjected to 50 hours at +55℃ with 3.0V. 4000HZ applied 在+55℃环境下, 输入 3.0V. 4000HZ 连续操作 50 小时 3. Low temperature 低温寿命测试 The part shall be subjected to 50 hours at -30℃ with 3.0V. 4000HZ applied 在-30℃环境下, 输入 3.0V. 4000HZ 连续操作 50 小时	After the test the part shall meet Specifications with-out any degradation in appearance and Performance except. SPL. after 4 hours at +25℃. the SPL. should be in +10dBA compared with initial one. 经测试后, 静置于+25℃(室温)环境中 4 小时后, 单体除音压外, 外观及电气特性须符合规格, 输出音压变化量需在±10dBA 内

TEST CONDITION.

Standard Test Condition : a) Temperature:+5~+35℃ b) Humidity:45-85% c) Pressure:860-1060mbar

一般测试条件 : a) 温度: +5~+35℃ b) 湿度:45-85% c) 气压: 860-1060mbar

Judament Test Condition: a) Temperature:+25±2℃ b) Humidity:60-70% c) Pressure:860-1060mbar

爭議时测试条件 : a) 温度: +25±2℃ b) 湿度: 60-70% c) 气压: 860-1060mbar

J.Recommended Temperature Profile For Reflow Oven 建議回焊爐溫度曲线

焊接区温度设置在 245 度左右, 选择挥发性成份少的锡膏

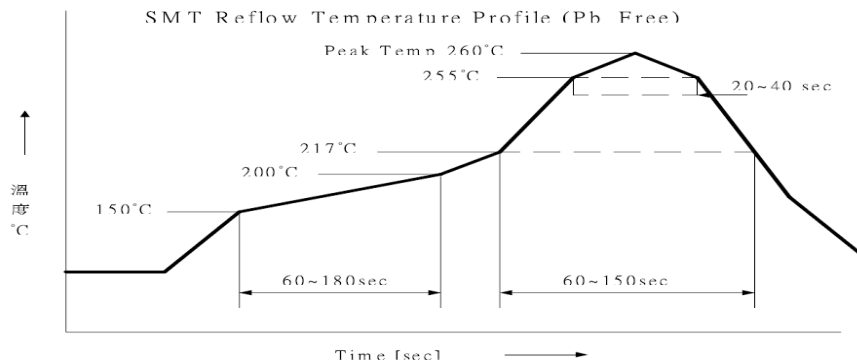

K.Recommended land pattern 建議基板設計尺寸圖

