

## 极低功耗、负电源轨输入、轨到轨输出、 完全差分放大器

 查询样品: **THS4524-EP**

### 特性

- 完全差分架构
- 带宽: **145MHz**
- 转换速率: **490V/μs**
- **HD<sub>2</sub>: 10kHz 时为 -133dBc (1 V<sub>RMS</sub>, R<sub>L</sub>=1kΩ)**
- **HD<sub>3</sub>: 10kHz 时为 -140dBc (1 V<sub>RMS</sub>, R<sub>L</sub>=1kΩ)**
- 输入电压噪声: **4.6nV/√Hz(f=100kHz)**
- 总谐波失真 (THD)+N: **1kHz 时为 -112dBc (0.00025%) (22kHz BW, G=1, 5 V<sub>PP</sub>)**
- 开环路增益: **119dB**
- **NRI** — 负电源轨输入
- **RRO** — 轨到轨输出
- 输出共模控制 (具有低偏移和漂移)
- 电源:
  - 电压: **2.5V (±1.25V) 至 5.5V (±2.75V)**
  - 电流: **1.14 mA/通道(ch)**
- 省电功能: **20μA** (典型值)

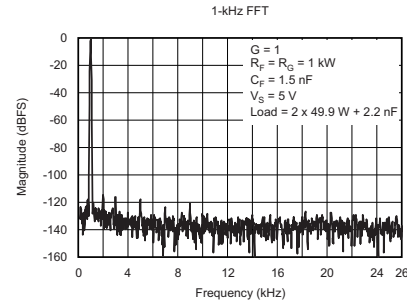
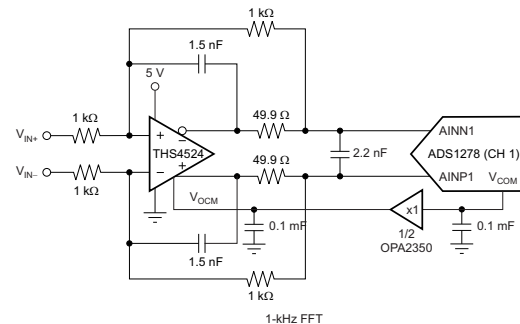
### 应用范围

- 低功耗逐次逼近 (**SAR**) 和三角积分 (**ΔΣ**) 模数转换器 (**ADC**) 驱动器
- 低功耗差分驱动器
- 低功耗差分信号调节
- 低功耗、高性能差分音频放大器

### 支持国防、航空航天、和医疗应用

- 受控基线
- 一个组装/测试场所
- 一个制造场所
- 军用温度范围 (**-55°C/125°C**) 内可用 <sup>(1)</sup>
- 延长的产品生命周期
- 延长的产品变更通知
- 产品可追溯性

THS4524 and ADS1278 Combined Performance



Tone (Hz)	Signal (dBFS)	SNR (dBc)	THD (dBc)	SINAD (dBc)	SFDR (dBc)
1 k	-0.50	109.1	-107.9	105.5	113.7

(1) 可提供额外温度范围-请与厂家联系

### 说明

THS4524 是一款低功耗、完全差分运算放大器，此放大器带有轨到轨输出和一个包括负电源轨在内的输入共模范围。这个放大器设计用于低功耗数据采集系统和高密度应用，在此类应用中功率耗散是一个关键参数，此放大器还在音频应用中提供出色的性能。



Please be aware that an important notice concerning availability, standard warranty, and use in critical applications of Texas Instruments semiconductor products and disclaimers thereto appears at the end of this data sheet.

I<sup>2</sup>S is a trademark of NXP Semiconductor.

All other trademarks are the property of their respective owners.

PRODUCTION DATA information is current as of publication date. Products conform to specifications per the terms of the Texas Instruments standard warranty. Production processing does not necessarily include testing of all parameters.

## THS4524-EP

ZHCS944A – JUNE 2012 – REVISED AUGUST 2013

[www.ti.com.cn](http://www.ti.com.cn)

这个完全差分运算放大器特有精准的输出共模控制，此控制可在驱动模数转换器 (ADC) 时实现 dc 耦合。与一个低于负电源轨和轨到轨输出的输入共模范围相耦合，这个控制可以很容易的实现与单端、地面基准信号源对接。除此之外，THS4524 非常适合用于驱动逐次逼近寄存器 (SAR) 和只使用一个单 +2.5V 至 +5V 和地面电源的三角积分 ( $\Delta\Sigma$ ) ADC。

THS4524 完全差分运算放大器可在  $-55^{\circ}\text{C}$  至  $125^{\circ}\text{C}$  的完全工业温度范围内运行。

### 相关 产品

器件	带宽 (BW) (MHz)	$I_Q$ (mA)	100kHz 时的 THD (dBc)	$V_N$ (nV/ $\sqrt{\text{Hz}}$ )	轨到轨
<a href="#">THS4520</a>	570	15.3	-114	2	输出
<a href="#">THS4121</a>	100	16	-79	5.4	输入/输出
<a href="#">THS4130</a>	150	16	-107	1.3	否



This integrated circuit can be damaged by ESD. Texas Instruments recommends that all integrated circuits be handled with appropriate precautions. Failure to observe proper handling and installation procedures can cause damage.

ESD damage can range from subtle performance degradation to complete device failure. Precision integrated circuits may be more susceptible to damage because very small parametric changes could cause the device not to meet its published specifications.

### PACKAGE/ORDERING INFORMATION<sup>(1)</sup>

T <sub>A</sub>	PACKAGE-LEAD	PACKAGE DESIGNATOR	ORDERABLE PART NUMBER	TOP-SIDE MARKING	VID NUMBER	
-55°C to 125°C	TSSOP - 38	DBT	Tape and reel, 2000	THS4524MDBTREP	THS4524EP	V62/12612-01XE
			Rails, 50	THS4524MDBTEP	THS4524EP	V62/12612-01XE-T

(1) For the most current package and ordering information, see the Package Option Addendum at the end of this document, or visit the device product folder at [www.ti.com](http://www.ti.com).

### ABSOLUTE MAXIMUM RATINGS<sup>(1)</sup>

Over operating free-air temperature range (unless otherwise noted).

		THS4524	UNIT
Supply Voltage, V <sub>S-</sub> to V <sub>S+</sub>		5.5	V
Input/Output Voltage, V <sub>I</sub> (V <sub>IN±</sub> , V <sub>OUT±</sub> , V <sub>OCM</sub> pins)		(V <sub>S-</sub> ) – 0.7 to (V <sub>S+</sub> ) + 0.7V	V
Differential Input Voltage, V <sub>ID</sub>		1	V
Output Current, I <sub>O</sub>		100	mA
Input Current, I <sub>I</sub> (V <sub>IN±</sub> , V <sub>OCM</sub> pins)		10	mA
Continuous Power Dissipation		See Thermal Characteristic Specifications	
Maximum Junction Temperature, T <sub>J</sub>		+150	°C
Maximum Junction Temperature, T <sub>J</sub> (continuous operation, long-term reliability)		+125	°C
Operating Free-air Temperature Range, T <sub>A</sub>		–55 to 125	°C
Storage Temperature Range, T <sub>STG</sub>		–65 to +150	°C
ESD Rating:	Human Body Model (HBM)	1300	V
	Charge Device Model (CDM)	1000	V
	Machine Model (MM)	50	V

(1) Stresses beyond those listed under *Absolute Maximum Ratings* may cause permanent damage to the device. These are stress ratings only, and functional operation of the device at these or any other conditions beyond those indicated is not implied. Exposure to absolute-maximum-rated conditions for extended periods may affect device reliability.

**THERMAL INFORMATION**

THERMAL METRIC <sup>(1)</sup>		THS4524	UNITS
		DBT	
		38 PINS	
$\theta_{JA}$	Junction-to-ambient thermal resistance <sup>(2)</sup>	106.9	°C/W
$\theta_{JCTop}$	Junction-to-case (top) thermal resistance <sup>(3)</sup>	59.8	
$\theta_{JB}$	Junction-to-board thermal resistance <sup>(4)</sup>	66.5	
$\psi_{JT}$	Junction-to-top characterization parameter <sup>(5)</sup>	17.1	
$\psi_{JB}$	Junction-to-board characterization parameter <sup>(6)</sup>	66.1	
$\theta_{JCbott}$	Junction-to-case (bottom) thermal resistance <sup>(7)</sup>	N/A	

- (1) 有关传统和全新热度的更多信息，请参阅 *IC 封装热量度* 应用报告（文献号：ZHCA543）。
- (2) 在 JESD51-2a 描述的环境中，按照 JESD51-7 的规定，在一个 JEDEC 标准高 K 电路板上进行仿真，从而获得自然对流条件下的结至环境热阻。
- (3) 通过在封装顶部模拟一个冷板测试来获得结至芯片外壳（顶部）的热阻。不存在特定的 JEDEC 标准测试，但可在 ANSI SEMI 标准 G30-88 中找到内容接近的说明。
- (4) 按照 JESD51-8 中的说明，通过在配有用于控制 PCB 温度的环形冷板夹具的环境中进行仿真，以获得结至电路板的热阻。
- (5) 结至顶部的特征参数，( $\psi_{JT}$ )，估算真实系统中器件的结温，并使用 JESD51-2a（第 6 章和第 7 章）中描述的程序从仿真数据中提取出该参数以便获得  $\theta_{JA}$ 。
- (6) 结至电路板特征参数，( $\psi_{JB}$ )，估算真实系统中器件的结温，并使用 JESD51-2a（第 6 章和第 7 章）中描述的程序从仿真数据中提取出该参数以便获得  $\theta_{JA}$ 。
- (7) 通过在外露（电源）焊盘上进行冷板测试仿真来获得结至芯片外壳（底部）热阻。不存在特定的 JEDEC 标准测试，但可在 ANSI SEMI 标准 G30-88 中找到了内容接近的说明。

**ELECTRICAL CHARACTERISTICS:  $V_{S+} - V_{S-} = 3.3\text{ V}$** 

At  $V_{S+} = +3.3\text{ V}$ ,  $V_{S-} = 0\text{ V}$ ,  $V_{OCM} = \text{open}$ ,  $V_{OUT} = 2\text{ V}_{PP}$  (differential),  $R_L = 1\text{ k}\Omega$  differential,  $G = 1\text{ V/V}$ , single-ended input, differential output, and input and output referenced to midsupply, unless otherwise noted.

PARAMETER	CONDITIONS	$T_A = -55^\circ\text{C to } 125^\circ\text{C}$			UNIT	TEST LEVEL <sup>(1)</sup>
		MIN	TYP	MAX		
<b>AC PERFORMANCE</b>						
Small-Signal Bandwidth	$V_{OUT} = 100\text{ mV}_{PP}$ , $G = 1$		135		MHz	C
	$V_{OUT} = 100\text{ mV}_{PP}$ , $G = 2$		49		MHz	C
	$V_{OUT} = 100\text{ mV}_{PP}$ , $G = 5$		18.6		MHz	C
	$V_{OUT} = 100\text{ mV}_{PP}$ , $G = 10$		9.3		MHz	C
Gain Bandwidth Product	$V_{OUT} = 100\text{ mV}_{PP}$ , $G = 10$		93		MHz	C
Large-Signal Bandwidth	$V_{OUT} = 2\text{ V}_{PP}$ , $G = 1$		95		MHz	C
Bandwidth for 0.1-dB Flatness	$V_{OUT} = 2\text{ V}_{PP}$ , $G = 1$		20		MHz	C
Rising Slew Rate (Differential)	$V_{OUT} = 2\text{-V Step}$ , $G = 1$ , $R_L = 200\ \Omega$		420		V/ $\mu\text{s}$	C
Falling Slew Rate (Differential)	$V_{OUT} = 2\text{-V Step}$ , $G = 1$ , $R_L = 200\ \Omega$		460		V/ $\mu\text{s}$	C
Overshoot	$V_{OUT} = 2\text{-V Step}$ , $G = 1$ , $R_L = 200\ \Omega$		1.2		%	C
Undershoot	$V_{OUT} = 2\text{-V Step}$ , $G = 1$ , $R_L = 200\ \Omega$		2.1		%	C
Rise Time	$V_{OUT} = 2\text{-V Step}$ , $G = 1$ , $R_L = 200\ \Omega$		4		ns	C
Fall Time	$V_{OUT} = 2\text{-V Step}$ , $G = 1$ , $R_L = 200\ \Omega$		3.5		ns	C
Settling Time to 1%	$V_{OUT} = 2\text{-V Step}$ , $G = 1$ , $R_L = 200\ \Omega$		13		ns	C
Harmonic Distortion						
2nd harmonic	$f = 1\text{ kHz}$ , $V_{OUT} = 1\text{ V}_{RMS}$ , $G = 1$ <sup>(2)</sup> , differential input		-122		dBc	C
	$f = 1\text{ MHz}$ , $V_{OUT} = 2\text{ V}_{PP}$ , $G = 1$		-85		dBc	C
3rd harmonic	$f = 1\text{ kHz}$ , $V_{OUT} = 1\text{ V}_{RMS}$ , $G = 1$ <sup>(2)</sup> , differential input		-141		dBc	C
	$f = 1\text{ MHz}$ , $V_{OUT} = 2\text{ V}_{PP}$ , $G = 1$		-90		dBc	C
Second-Order Intermodulation Distortion	Two-tone, $f_1 = 2\text{ MHz}$ , $f_2 = 2.2\text{ MHz}$ , $V_{OUT} = 2\text{-V}_{PP}$ envelope		-83		dBc	C

- (1) Test levels: **(A)** 100% tested. **(B)** Limits set by characterization and simulation. **(C)** Typical value only for information.
- (2) Not directly measurable; calculated using noise gain of 101 as described in the Applications section, [Audio Performance](#).

**ELECTRICAL CHARACTERISTICS:  $V_{S+} - V_{S-} = 3.3\text{ V}$  (continued)**

At  $V_{S+} = +3.3\text{ V}$ ,  $V_{S-} = 0\text{ V}$ ,  $V_{OCM} = \text{open}$ ,  $V_{OUT} = 2\text{ V}_{PP}$  (differential),  $R_L = 1\text{ k}\Omega$  differential,  $G = 1\text{ V/V}$ , single-ended input, differential output, and input and output referenced to midsupply, unless otherwise noted.

PARAMETER	CONDITIONS	$T_A = -55^\circ\text{C to } 125^\circ\text{C}$			UNIT	TEST LEVEL <sup>(1)</sup>
		MIN	TYP	MAX		
Third-Order Intermodulation Distortion	Two-tone, $f_1 = 2\text{ MHz}$ , $f_2 = 2.2\text{ MHz}$ , $V_{OUT} = 2\text{-}V_{PP}$ envelope		-90		dBc	C
Input Voltage Noise	$f > 10\text{ kHz}$		4.6		$\text{nV}/\sqrt{\text{Hz}}$	C
Input Current Noise	$f > 100\text{ kHz}$		0.6		$\text{pA}/\sqrt{\text{Hz}}$	C
Overdrive Recovery Time	Overdrive = $\pm 0.5\text{ V}$		80		ns	C
Output Balance Error	$V_{OUT} = 100\text{ mV}$ , $f \leq 2\text{ MHz}$ (differential input)		-57		dB	C
Closed-Loop Output Impedance	$f = 1\text{ MHz}$ (differential)		0.3		$\Omega$	C
Channel-to-Channel Crosstalk	$f = 10\text{ kHz}$ , measured differentially		-125		dB	C
<b>DC PERFORMANCE</b>						
Open-Loop Voltage Gain ( $A_{OL}$ )		80	116		dB	A
Input-Referred Offset Voltage			$\pm 0.5$	$\pm 7$	mV	A
Input offset voltage drift <sup>(3)</sup>			$\pm 2$		$\mu\text{V}/^\circ\text{C}$	C
Input Bias Current			0.75	3.8	$\mu\text{A}$	A
Input bias current drift <sup>(3)</sup>			$\pm 1.75$		$\text{nA}/^\circ\text{C}$	C
Input Offset Current			$\pm 0.03$	$\pm 2.0$	$\mu\text{A}$	A
Input offset current drift <sup>(3)</sup>			$\pm 0.1$		$\text{nA}/^\circ\text{C}$	C

(3) Input Offset Voltage Drift, Input Bias Current Drift, and Input Offset Current Drift are average values calculated by taking data at  $-55^\circ\text{C}$  and  $+125^\circ\text{C}$ , computing the difference, and dividing by 180.

# THS4524-EP

ZHCS944A – JUNE 2012 – REVISED AUGUST 2013

[www.ti.com.cn](http://www.ti.com.cn)

## ELECTRICAL CHARACTERISTICS: $V_{S+} - V_{S-} = 3.3 \text{ V}$ (continued)

 At  $V_{S+} = +3.3 \text{ V}$ ,  $V_{S-} = 0 \text{ V}$ ,  $V_{OCM} = \text{open}$ ,  $V_{OUT} = 2 V_{PP}$  (differential),  $R_L = 1 \text{ k}\Omega$  differential,  $G = 1 \text{ V/V}$ , single-ended input, differential output, and input and output referenced to midsupply, unless otherwise noted.

PARAMETER	CONDITIONS	$T_A = -55^\circ\text{C to } 125^\circ\text{C}$			UNIT	TEST LEVEL <sup>(1)</sup>
		MIN	TYP	MAX		
<b>INPUT</b>						
Common-Mode Input Voltage Low			-0.1	0	V	A
Common-Mode Input Voltage High		1.8	1.9		V	A
Common-Mode Rejection Ratio (CMRR)		73.8	100		dB	A
Input Resistance			110  1.5		k  pF	C
<b>OUTPUT</b>						
Output Voltage Low			0.09	0.2	V	A
Output Voltage High		2.95	3.05		V	A
Output Current Drive (for linear operation)	$R_L = 50 \Omega$		$\pm 35$		mA	C
<b>POWER SUPPLY</b>						
Specified Operating Voltage		2.5		5.5	V	A
Quiescent Operating Current, per channel		0.85	1.0	1.25	mA	A
Power-Supply Rejection Ratio ( $\pm$ PSRR)		65	100		dB	A
<b>POWER DOWN</b>						
Enable Voltage Threshold	Assured on above 2.1 V		1.6	2.1	V	A
Disable Voltage Threshold	Assured off below 0.7 V	0.7	1.6		V	A
Disable Pin Bias Current			1		$\mu$ A	C
Power Down Quiescent Current			10		$\mu$ A	C
Turn-On Time Delay	Time to $V_{OUT} = 90\%$ of final value, $V_{IN} = 2 \text{ V}$ , $R_L = 200 \Omega$		108		ns	C
Turn-Off Time Delay	Time to $V_{OUT} = 10\%$ of original value, $V_{IN} = 2 \text{ V}$ , $R_L = 200 \Omega$		88		ns	C
<b><math>V_{OCM}</math> VOLTAGE CONTROL</b>						
Small-Signal Bandwidth			23		MHz	C
Slew Rate			55		V/ $\mu$ s	C
Gain		0.98	0.99	1.021	V/V	A
Common-Mode Offset Voltage from $V_{OCM}$ Input	Measured at $V_{OUT}$ with $V_{OCM}$ input driven, $V_{OCM} = 1.65 \text{ V} \pm 0.5 \text{ V}$		$\pm 2.5$	$\pm 7$	mV	A
Input Bias Current	$V_{OCM} = 1.65 \text{ V} \pm 0.5 \text{ V}$		$\pm 5$	$\pm 8$	$\mu$ A	A
$V_{OCM}$ Voltage Range			0.8 to 2.5		V	C
Input Impedance			72  1.5		k  pF	C
Default Output Common-Mode Voltage Offset from $(V_{S+} - V_{S-})/2$	Measured at $V_{OUT}$ with $V_{OCM}$ input open		$\pm 1.5$	$\pm 5$	mV	A

**ELECTRICAL CHARACTERISTICS:  $V_{S+} - V_{S-} = 5\text{ V}$** 

At  $V_{S+} = +5\text{ V}$ ,  $V_{S-} = 0\text{ V}$ ,  $V_{OCM} = \text{open}$ ,  $V_{OUT} = 2\text{ V}_{PP}$  (differential),  $R_F = 1\text{ k}\Omega$ ,  $R_L = 1\text{ k}\Omega$  differential,  $G = 1\text{ V/V}$ , single-ended input, differential output, input and output referenced to midsupply, unless otherwise noted.

PARAMETER	CONDITIONS	$T_A = -55^\circ\text{C to } 125^\circ\text{C}$			UNIT	TEST LEVEL <sup>(1)</sup>
		MIN	TYP	MAX		
<b>AC PERFORMANCE</b>						
Small-Signal Bandwidth	$V_{OUT} = 100\text{ mV}_{PP}$ , $G = 1$		145		MHz	C
	$V_{OUT} = 100\text{ mV}_{PP}$ , $G = 2$		50		MHz	C
	$V_{OUT} = 100\text{ mV}_{PP}$ , $G = 5$		20		MHz	C
	$V_{OUT} = 100\text{ mV}_{PP}$ , $G = 10$		9.5		MHz	C
Gain Bandwidth Product	$V_{OUT} = 100\text{ mV}_{PP}$ , $G = 10$		95		MHz	C
Large-Signal Bandwidth	$V_{OUT} = 2\text{ V}_{PP}$ , $G = 1$		145		MHz	C
Bandwidth for 0.1-dB Flatness	$V_{OUT} = 2\text{ V}_{PP}$ , $G = 1$		30		MHz	C
Rising Slew Rate (Differential)	$V_{OUT} = 2\text{-V Step}$ , $G = 1$ , $R_L = 200\ \Omega$		490		V/ $\mu\text{s}$	C
Falling Slew Rate (Differential)	$V_{OUT} = 2\text{-V Step}$ , $G = 1$ , $R_L = 200\ \Omega$		600		V/ $\mu\text{s}$	C
Overshoot	$V_{OUT} = 2\text{-V Step}$ , $G = 1$ , $R_L = 200\ \Omega$		1		%	C
Undershoot	$V_{OUT} = 2\text{-V Step}$ , $G = 1$ , $R_L = 200\ \Omega$		2.6		%	C
Rise Time	$V_{OUT} = 2\text{-V Step}$ , $G = 1$ , $R_L = 200\ \Omega$		3.4		ns	C
Fall Time	$V_{OUT} = 2\text{-V Step}$ , $G = 1$ , $R_L = 200\ \Omega$		3		ns	C
Settling Time to 1%	$V_{OUT} = 2\text{-V Step}$ , $G = 1$ , $R_L = 200\ \Omega$		10		ns	C
Harmonic Distortion						
2nd harmonic	$f = 1\text{ kHz}$ , $V_{OUT} = 1\text{ V}_{RMS}$ , $G = 1^{(2)}$ , differential input		-122		dBc	C
	$f = 1\text{ MHz}$ , $V_{OUT} = 2\text{ V}_{PP}$ , $G = 1$		-85		dBc	C
3rd harmonic	$f = 1\text{ kHz}$ , $V_{OUT} = 1\text{ V}_{RMS}$ , $G = 1^{(2)}$ , differential input		-141		dBc	C
	$f = 1\text{ MHz}$ , $V_{OUT} = 2\text{ V}_{PP}$ , $G = 1$		-91		dBc	C
Second-Order Intermodulation Distortion	Two-tone, $f_1 = 2\text{ MHz}$ , $f_2 = 2.2\text{ MHz}$ , $V_{OUT} = 2\text{-V}_{PP}$ envelope		-86		dBc	C
Third-Order Intermodulation Distortion	Two-tone, $f_1 = 2\text{ MHz}$ , $f_2 = 2.2\text{ MHz}$ , $V_{OUT} = 2\text{-V}_{PP}$ envelope		-93		dBc	C
Input Voltage Noise	$f > 10\text{ kHz}$		4.6		nV/ $\sqrt{\text{Hz}}$	C
Input Current Noise	$f > 100\text{ kHz}$		0.6		pA/ $\sqrt{\text{Hz}}$	C
SNR	$V_{OUT} = 5\text{ V}_{PP}$ , 20 Hz to 22 kHz BW, differential input		114		dBc	C
THD+N	$f = 1\text{ kHz}$ , $V_{OUT} = 5\text{ V}_{PP}$ , 20 Hz to 22 kHz BW, differential input		112		dBc	C
Overdrive Recovery Time	Overdrive = $\pm 0.5\text{ V}$		75		ns	C
Output Balance Error	$V_{OUT} = 100\text{ mV}$ , $f < 2\text{ MHz}$ , $V_{IN}$ differential		-57		dB	C
Closed-Loop Output Impedance	$f = 1\text{ MHz}$ (differential)		0.3		$\Omega$	C
Channel-to-Channel Crosstalk	$f = 10\text{ kHz}$ , measured differentially		-125		dB	C
<b>DC PERFORMANCE</b>						
Open-Loop Voltage Gain ( $A_{OL}$ )		83	119		dB	A
Input-Referred Offset Voltage			$\pm 0.5$	$\pm 8$	mV	A
Input offset voltage drift <sup>(3)</sup>			$\pm 2$		$\mu\text{V}/^\circ\text{C}$	C
Input Bias Current			0.9	5.5	$\mu\text{A}$	A
Input bias current drift <sup>(3)</sup>			$\pm 1.8$		nA/ $^\circ\text{C}$	C

(1) Test levels: **(A)** 100% tested. **(B)** Limits set by characterization and simulation. **(C)** Typical value only for information.

(2) Not directly measurable; calculated using noise gain of 101 as described in the Applications section, [Audio Performance](#).

(3) Input Offset Voltage Drift, Input Bias Current Drift, and Input Offset Current Drift are average values calculated by taking data at  $-55^\circ\text{C}$  and  $+125^\circ\text{C}$ , computing the difference, and dividing by 180.

# THS4524-EP

ZHCS944A – JUNE 2012 – REVISED AUGUST 2013

[www.ti.com.cn](http://www.ti.com.cn)

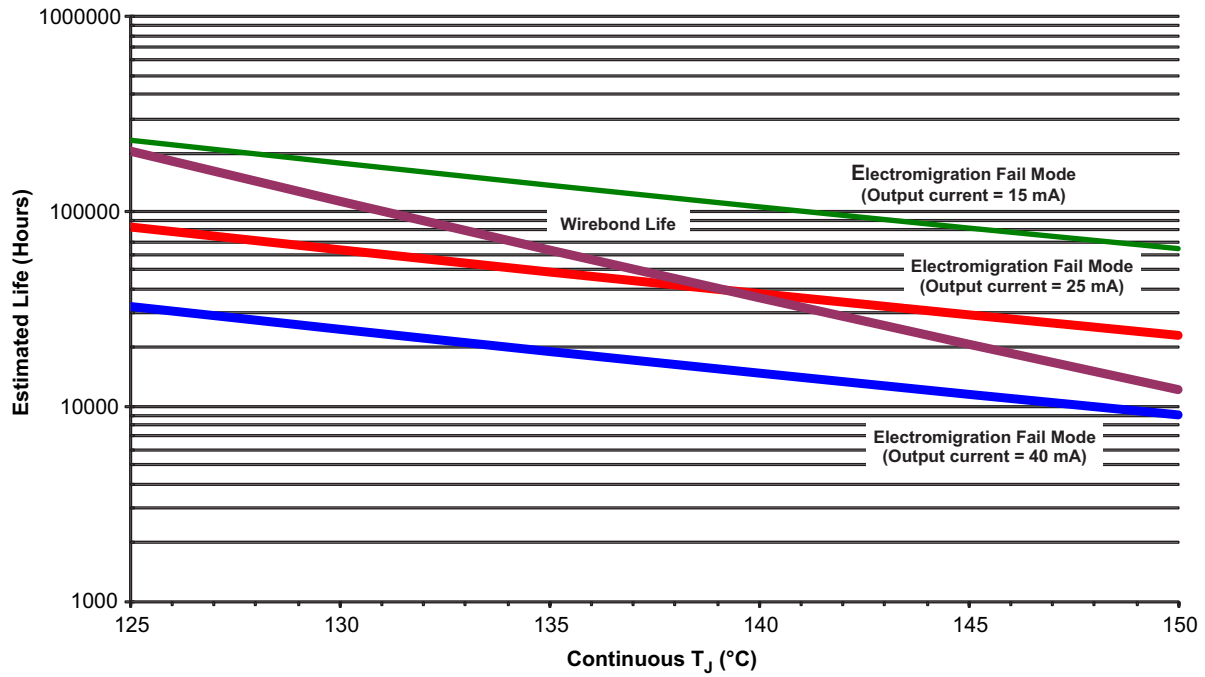
## ELECTRICAL CHARACTERISTICS: $V_{S+} - V_{S-} = 5\text{ V}$ (continued)

At  $V_{S+} = +5\text{ V}$ ,  $V_{S-} = 0\text{ V}$ ,  $V_{OCM} = \text{open}$ ,  $V_{OUT} = 2\text{ V}_{PP}$  (differential),  $R_F = 1\text{ k}\Omega$ ,  $R_L = 1\text{ k}\Omega$  differential,  $G = 1\text{ V/V}$ , single-ended input, differential output, input and output referenced to midsupply, unless otherwise noted.

PARAMETER	CONDITIONS	$T_A = -55^\circ\text{C to } 125^\circ\text{C}$			UNIT	TEST LEVEL <sup>(1)</sup>
		MIN	TYP	MAX		
Input Offset Current			$\pm 0.03$	$\pm 1.7$	$\mu\text{A}$	A
Input offset current drift <sup>(4)</sup>			$\pm 0.1$		$\text{nA}/^\circ\text{C}$	C
<b>INPUT</b>						
Common-Mode Input Voltage Low			-0.1	0	V	A
Common-Mode Input Voltage High		3.5	3.6		V	A
Common-Mode Rejection Ratio (CMRR)		80	102		dB	A
Input Impedance			100  0.7		$\text{k}\Omega  \mu\text{F}$	C
<b>OUTPUT</b>						
Output Voltage Low			0.115	0.2	V	A
Output Voltage High		4.65	4.7		V	A
Output Current Drive (for linear operation)	$R_L = 50\ \Omega$		$\pm 55$		mA	C
<b>POWER SUPPLY</b>						
Specified Operating Voltage		2.5		5.5	V	A
Quiescent Operating Current, per channel		0.9	1.15	1.4	mA	A
Power-Supply Rejection Ratio ( $\pm\text{PSRR}$ )		62	100		dB	A
<b>POWER DOWN</b>						
Enable Voltage Threshold	Ensured on above 2.1 V		1.6	2.1	V	A
Disable Voltage Threshold	Ensured off below 0.7 V	0.7	1.6		V	A
Disable Pin Bias Current			1		$\mu\text{A}$	C
Power Down Quiescent Current			20		$\mu\text{A}$	C
Turn-On Time Delay	Time to $V_{OUT} = 90\%$ of final value, $V_{IN} = 2\text{ V}$ , $R_L = 200\ \Omega$		70		ns	C
Turn-Off Time Delay	Time to $V_{OUT} = 10\%$ of original value, $V_{IN} = 2\text{ V}$ , $R_L = 200\ \Omega$		60		ns	C
<b><math>V_{OCM}</math> VOLTAGE CONTROL</b>						
Small-Signal Bandwidth			23		MHz	C
Slew Rate			55		$\text{V}/\mu\text{s}$	C
Gain		0.98	0.99	1.021	V/V	A
Common-Mode Offset Voltage from $V_{OCM}$ Input	Measured at $V_{OUT}$ with $V_{OCM}$ input driven, $V_{OCM} = 2.5\text{ V} \pm 1\text{ V}$		$\pm 5$	$\pm 12.5$	mV	A
Input Bias Current	$V_{OCM} = 2.5\text{ V} \pm 1\text{ V}$		$\pm 20$	$\pm 25$	$\mu\text{A}$	A
$V_{OCM}$ Voltage Range			0.8 to 4.2		V	C
Input Impedance			46  1.5		$\text{k}\Omega  \mu\text{F}$	C
Default Output Common-Mode Voltage Offset from $(V_{S+} - V_{S-})/2$	Measured at $V_{OUT}$ with $V_{OCM}$ input open		$\pm 1$	$\pm 8$	mV	A

(4) Input Offset Voltage Drift, Input Bias Current Drift, and Input Offset Current Drift are average values calculated by taking data at  $-55^\circ\text{C}$  and  $+125^\circ\text{C}$ , computing the difference, and dividing by 180.



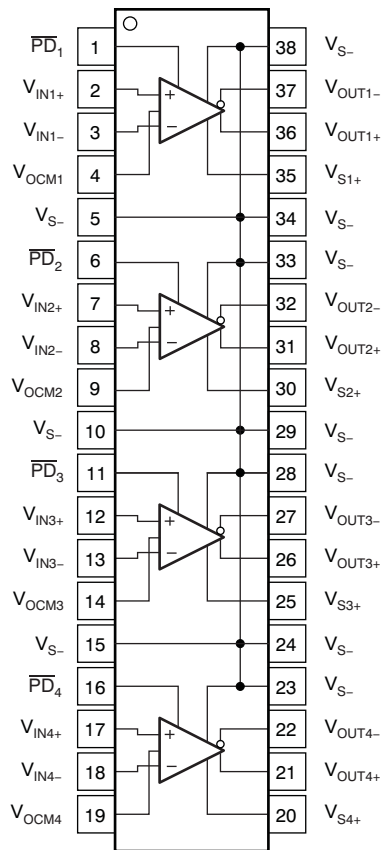


- A. See datasheet for absolute maximum and minimum recommended operating conditions.
- B. Silicon operating life design goal is 10 years at 105°C junction temperature (does not include package interconnect life).

**Figure 1. Electromigration Fail Mode/Wirebond Life Derating Chart**

**DEVICE INFORMATION**

**TSSOP-38 (DBT PACKAGE)  
(TOP VIEW)**



**TERMINAL FUNCTIONS**

TSSOP-38		DESCRIPTION
PIN NO.	NAME	
1	$\overline{\text{PD}}_1$	Power down 1. $\overline{\text{PD}}$ = logic low puts channel into low-power mode. $\overline{\text{PD}}$ = logic high or open for normal operation.
2	$V_{\text{IN}1+}$	Noninverting amplifier 1 input
3	$V_{\text{IN}1-}$	Inverting amplifier 1 input
4	$V_{\text{OCM}1}$	Common-mode voltage input 1
5	$V_{\text{S}-}$	Negative power-supply input. Note that $V_{\text{S}-}$ is tied together on multi-channel devices.
6	$\overline{\text{PD}}_2$	Power down 2. $\overline{\text{PD}}$ = logic low puts channel into low-power mode. $\overline{\text{PD}}$ = logic high or open for normal operation.
7	$V_{\text{IN}2+}$	Noninverting amplifier 2 input
8	$V_{\text{IN}2-}$	Inverting amplifier 2 input
9	$V_{\text{OCM}2}$	Common-mode voltage input 2
10	$V_{\text{S}-}$	Negative power-supply input. Note that $V_{\text{S}-}$ is tied together on multi-channel devices.
11	$\overline{\text{PD}}_3$	Power down 3. $\overline{\text{PD}}$ = logic low puts channel into low-power mode. $\overline{\text{PD}}$ = logic high or open for normal operation.
12	$V_{\text{IN}3+}$	Noninverting amplifier 3 input
13	$V_{\text{IN}3-}$	Inverting amplifier 3 input
14	$V_{\text{OCM}3}$	Common-mode voltage input 3
15	$V_{\text{S}-}$	Negative power-supply input. Note that $V_{\text{S}-}$ is tied together on multi-channel devices.
16	$\overline{\text{PD}}_4$	Power down 4. $\overline{\text{PD}}$ = logic low puts channel into low-power mode. $\overline{\text{PD}}$ = logic high or open for normal operation.
17	$V_{\text{IN}4+}$	Noninverting amplifier 4 input
18	$V_{\text{IN}4-}$	Inverting amplifier 4 input
19	$V_{\text{OCM}4}$	Common-mode voltage input 4
20	$V_{\text{S}4+}$	Amplifier 4 positive power-supply input
21	$V_{\text{OUT}4+}$	Noninverting amplifier 4 output
22	$V_{\text{OUT}4-}$	Inverting amplifier 4 output
23	$V_{\text{S}-}$	Negative power-supply input. Note that $V_{\text{S}-}$ is tied together on multi-channel devices.
24	$V_{\text{S}-}$	Negative power-supply input. Note that $V_{\text{S}-}$ is tied together on multi-channel devices.
25	$V_{\text{S}3+}$	Amplifier 3 positive power-supply input
26	$V_{\text{OUT}3+}$	Noninverting amplifier3 output
27	$V_{\text{OUT}3-}$	Inverting amplifier3 output
28	$V_{\text{S}-}$	Negative power-supply input. Note that $V_{\text{S}-}$ is tied together on multi-channel devices.
29	$V_{\text{S}-}$	Negative power-supply input. Note that $V_{\text{S}-}$ is tied together on multi-channel devices.
30	$V_{\text{S}2+}$	Amplifier 2 positive power-supply input
31	$V_{\text{OUT}2+}$	Noninverting amplifier 2 output
32	$V_{\text{OUT}2-}$	Inverting amplifier 2 output
33	$V_{\text{S}-}$	Negative power-supply input. Note that $V_{\text{S}-}$ is tied together on multi-channel devices.
34	$V_{\text{S}-}$	Negative power-supply input. Note that $V_{\text{S}-}$ is tied together on multi-channel devices.
35	$V_{\text{S}1+}$	Amplifier 1 positive power-supply input
36	$V_{\text{OUT}1+}$	Noninverting amplifier 1 output
37	$V_{\text{OUT}1-}$	Inverting amplifier 1 output
38	$V_{\text{S}-}$	Negative power-supply input. Note that $V_{\text{S}-}$ is tied together on multi-channel devices.

**TYPICAL CHARACTERISTICS**
**Table of Graphs:  $V_{S+} - V_{S-} = 3.3\text{ V}$** 

TITLE	FIGURE
Small-Signal Frequency Response	<a href="#">Figure 2</a>
Large-Signal Frequency Response	<a href="#">Figure 3</a>
Large- and Small-Signal Pulse Response	<a href="#">Figure 4</a>
Slew Rate vs $V_{OUT}$ Step	<a href="#">Figure 5</a>
Overdrive Recovery	<a href="#">Figure 6</a>
10-kHz Output Spectrum on AP Analyzer	<a href="#">Figure 7</a>
Harmonic Distortion vs Frequency	<a href="#">Figure 8</a>
Harmonic Distortion vs Output Voltage at 1 MHz	<a href="#">Figure 9</a>
Harmonic Distortion vs Gain at 1 MHz	<a href="#">Figure 10</a>
Harmonic Distortion vs Load at 1 MHz	<a href="#">Figure 11</a>
Harmonic Distortion vs $V_{OCM}$ at 1 MHz	<a href="#">Figure 12</a>
Two-Tone, Second- and Third-Order Intermodulation Distortion vs Frequency	<a href="#">Figure 13</a>
Single-Ended Output Voltage Swing vs Load Resistance	<a href="#">Figure 14</a>
Main Amplifier Differential Output Impedance vs Frequency	<a href="#">Figure 15</a>
Frequency Response vs $C_{LOAD}$ ( $R_{LOAD} = 1\text{ k}\Omega$ )	<a href="#">Figure 16</a>
$R_O$ vs $C_{LOAD}$ ( $R_{LOAD} = 1\text{ k}\Omega$ )	<a href="#">Figure 17</a>
Rejection Ratio vs Frequency	<a href="#">Figure 18</a>
Crosstalk (Measured Differentially)	<a href="#">Figure 19</a>
Turn-on Time	<a href="#">Figure 20</a>
Turn-off Time	<a href="#">Figure 21</a>
Input-Referred Voltage Noise and Current Noise Spectral Density	<a href="#">Figure 22</a>
Main Amplifier Differential Open-Loop Gain and Phase	<a href="#">Figure 23</a>
Output Balance Error vs Frequency	<a href="#">Figure 24</a>
$V_{OCM}$ Small-Signal Frequency Response	<a href="#">Figure 25</a>
$V_{OCM}$ Large-Signal Frequency Response	<a href="#">Figure 26</a>
$V_{OCM}$ Input Impedance vs Frequency	<a href="#">Figure 27</a>

**Table of Graphs:  $V_{S+} - V_{S-} = 5\text{ V}$** 

TITLE	FIGURE
Small-Signal Frequency Response	<a href="#">Figure 28</a>
Large-Signal Frequency Response	<a href="#">Figure 29</a>
Large- and Small-Signal Pulse Response	<a href="#">Figure 30</a>
Slew Rate vs $V_{OUT}$ Step	<a href="#">Figure 31</a>
Overdrive Recovery	<a href="#">Figure 32</a>
10-kHz Output Spectrum on AP Analyzer	<a href="#">Figure 33</a>
Harmonic Distortion vs Frequency	<a href="#">Figure 34</a>
Harmonic Distortion vs Output Voltage at 1 MHz	<a href="#">Figure 35</a>
Harmonic Distortion vs Gain at 1 MHz	<a href="#">Figure 36</a>
Harmonic Distortion vs Load at 1 MHz	<a href="#">Figure 37</a>
Harmonic Distortion vs $V_{OCM}$ at 1 MHz	<a href="#">Figure 38</a>
Two-Tone, Second- and Third-Order Intermodulation Distortion vs Frequency	<a href="#">Figure 39</a>
Single-Ended Output Voltage Swing vs Load Resistance	<a href="#">Figure 40</a>
Main Amplifier Differential Output Impedance vs Frequency	<a href="#">Figure 41</a>
Frequency Response vs $C_{LOAD}$ ( $R_{LOAD} = 1\text{ k}\Omega$ )	<a href="#">Figure 42</a>
$R_O$ vs $C_{LOAD}$ ( $R_{LOAD} = 1\text{ k}\Omega$ )	<a href="#">Figure 43</a>
Rejection Ratio vs Frequency	<a href="#">Figure 44</a>
Crosstalk (Measured Differentially)	<a href="#">Figure 45</a>
Turn-on Time	<a href="#">Figure 46</a>
Turn-off Time	<a href="#">Figure 47</a>
Input-Referred Voltage Noise and Current Noise Spectral Density	<a href="#">Figure 48</a>
Main Amplifier Differential Open-Loop Gain and Phase	<a href="#">Figure 49</a>
Output Balance Error vs Frequency	<a href="#">Figure 50</a>
$V_{OCM}$ Small-Signal Frequency Response	<a href="#">Figure 51</a>
$V_{OCM}$ Large-Signal Frequency Response	<a href="#">Figure 52</a>
$V_{OCM}$ Input Impedance vs Frequency	<a href="#">Figure 53</a>

**TYPICAL CHARACTERISTICS:  $V_{S+} - V_{S-} = 3.3\text{ V}$**

At  $V_{S+} = +3.3\text{ V}$ ,  $V_{S-} = 0\text{ V}$ ,  $V_{OCM} = \text{open}$ ,  $V_{OUT} = 2\text{ V}_{PP}$  (differential),  $R_L = 1\text{ k}\Omega$  differential,  $G = 1\text{ V/V}$ , single-ended input, differential output, and input and output referenced to midsupply, unless otherwise noted.

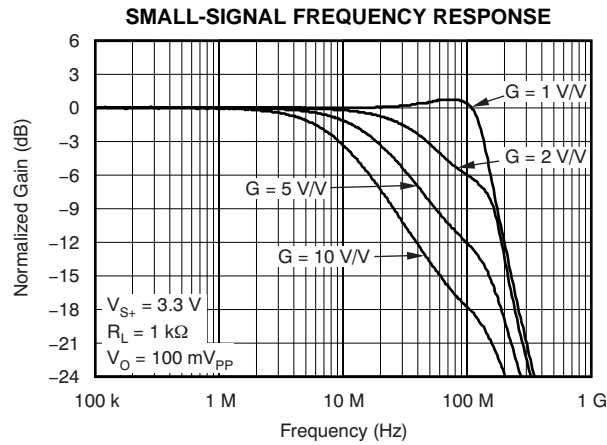


Figure 2.

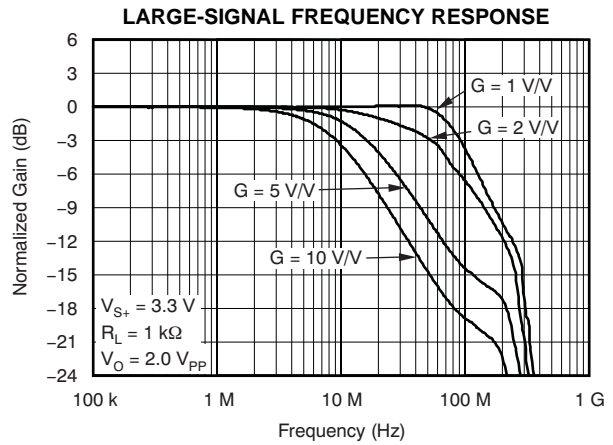


Figure 3.

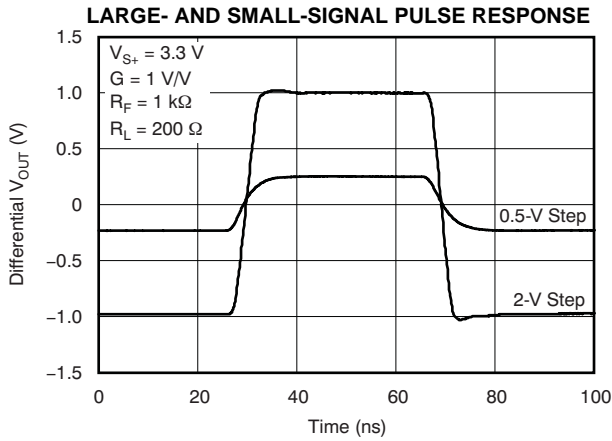


Figure 4.

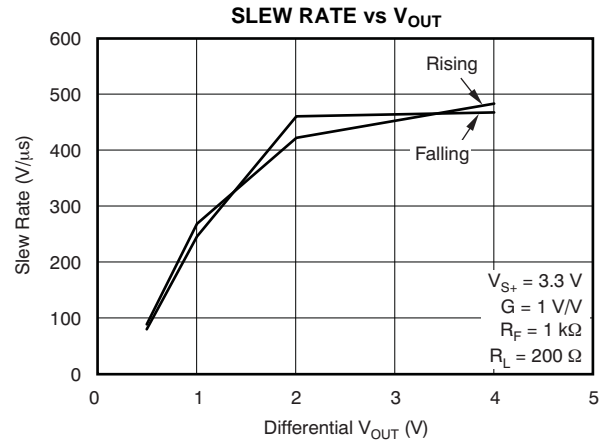


Figure 5.

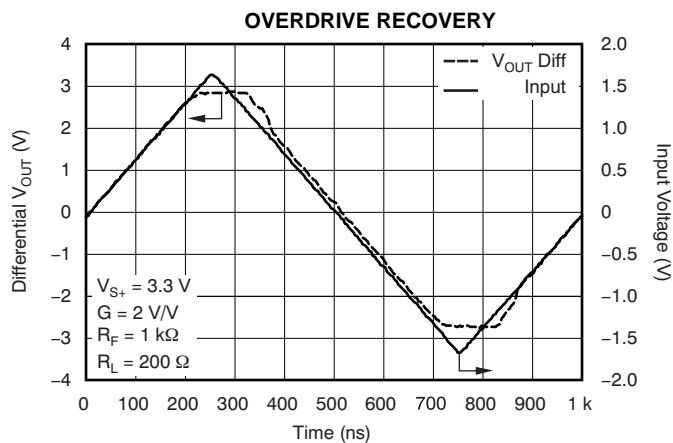


Figure 6.

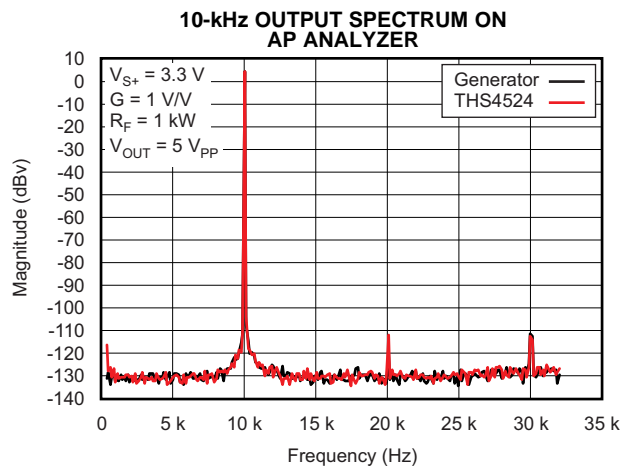


Figure 7.

**TYPICAL CHARACTERISTICS:  $V_{S+} - V_{S-} = 3.3\text{ V}$  (continued)**

At  $V_{S+} = +3.3\text{ V}$ ,  $V_{S-} = 0\text{ V}$ ,  $V_{OCM} = \text{open}$ ,  $V_{OUT} = 2\text{ V}_{PP}$  (differential),  $R_L = 1\text{ k}\Omega$  differential,  $G = 1\text{ V/V}$ , single-ended input, differential output, and input and output referenced to midsupply, unless otherwise noted.

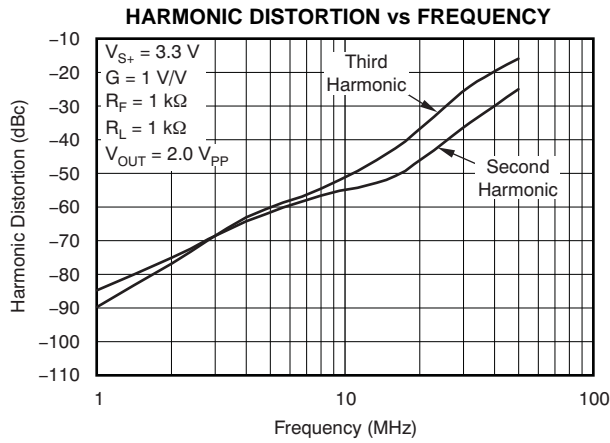


Figure 8.

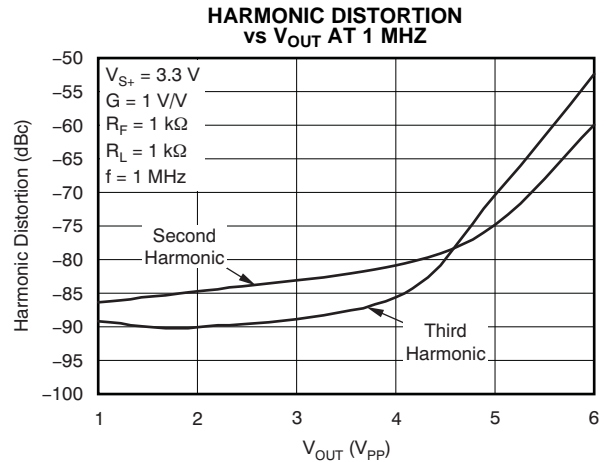


Figure 9.

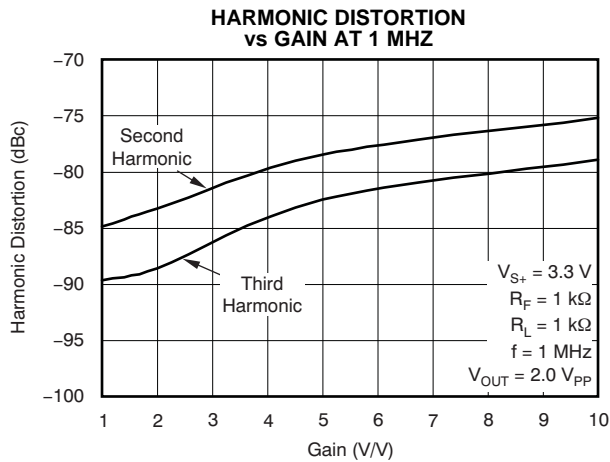


Figure 10.

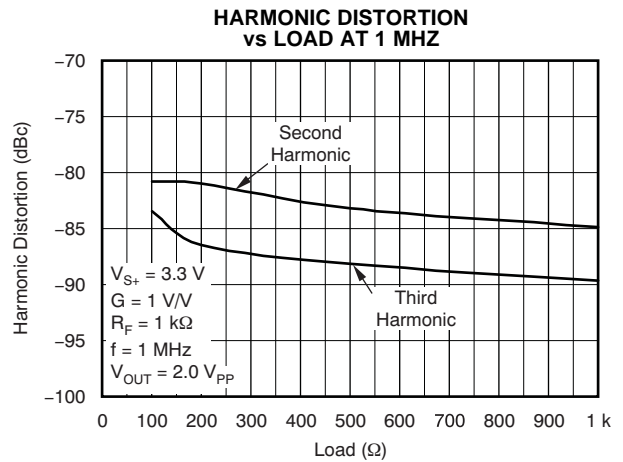


Figure 11.

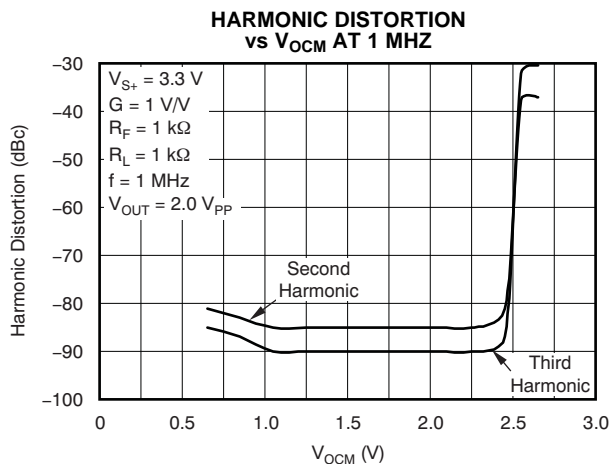


Figure 12.

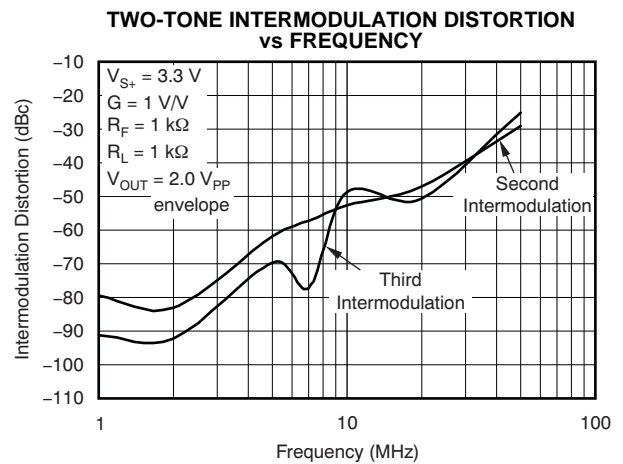


Figure 13.

**TYPICAL CHARACTERISTICS:  $V_{S+} - V_{S-} = 3.3\text{ V}$  (continued)**

At  $V_{S+} = +3.3\text{ V}$ ,  $V_{S-} = 0\text{ V}$ ,  $V_{OCM} = \text{open}$ ,  $V_{OUT} = 2\text{ V}_{PP}$  (differential),  $R_L = 1\text{ k}\Omega$  differential,  $G = 1\text{ V/V}$ , single-ended input, differential output, and input and output referenced to midsupply, unless otherwise noted.

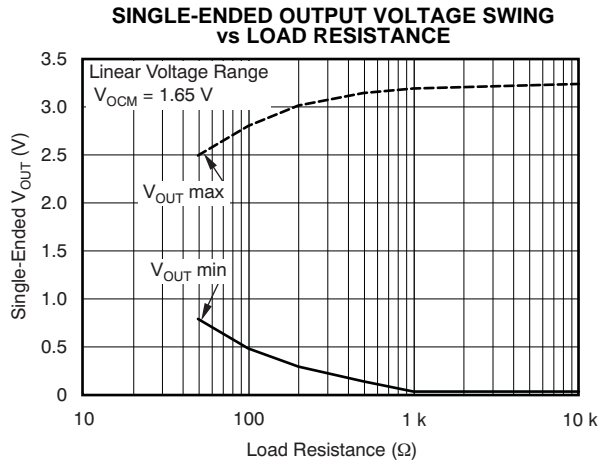


Figure 14.

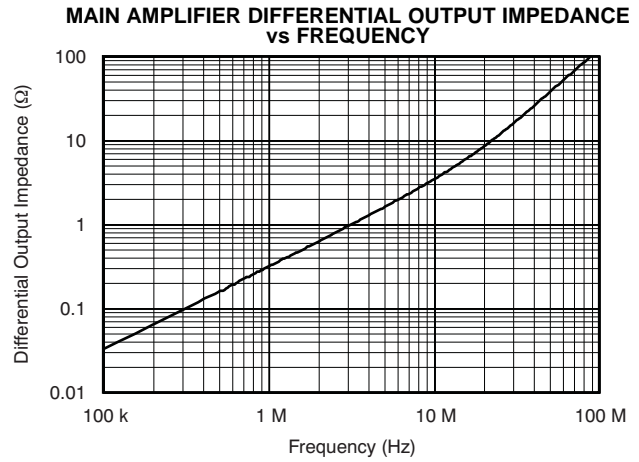


Figure 15.

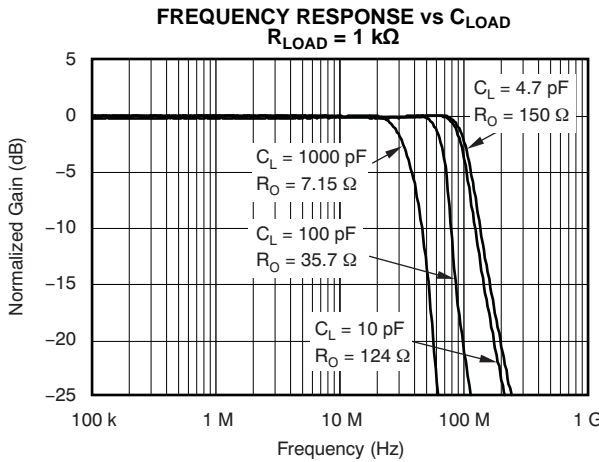


Figure 16.

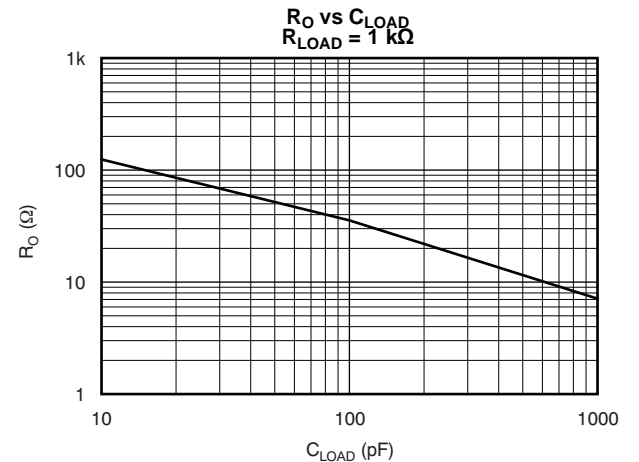


Figure 17.

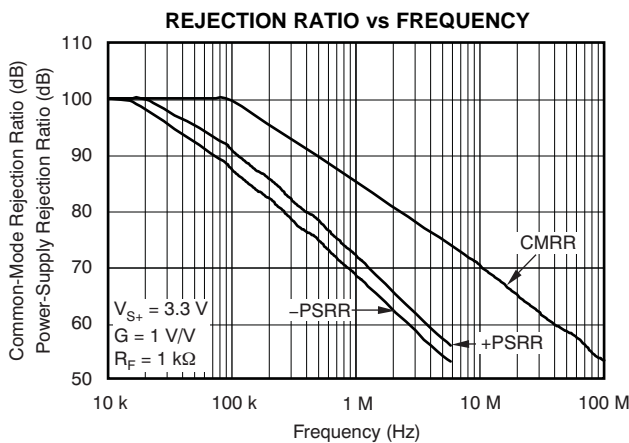


Figure 18.

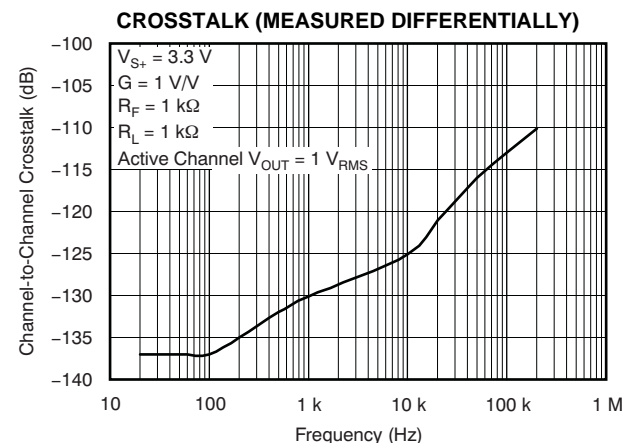


Figure 19.



**TYPICAL CHARACTERISTICS:  $V_{S+} - V_{S-} = 3.3\text{ V}$  (continued)**

At  $V_{S+} = +3.3\text{ V}$ ,  $V_{S-} = 0\text{ V}$ ,  $V_{OCM} = \text{open}$ ,  $V_{OUT} = 2\text{ V}_{PP}$  (differential),  $R_L = 1\text{ k}\Omega$  differential,  $G = 1\text{ V/V}$ , single-ended input, differential output, and input and output referenced to midsupply, unless otherwise noted.

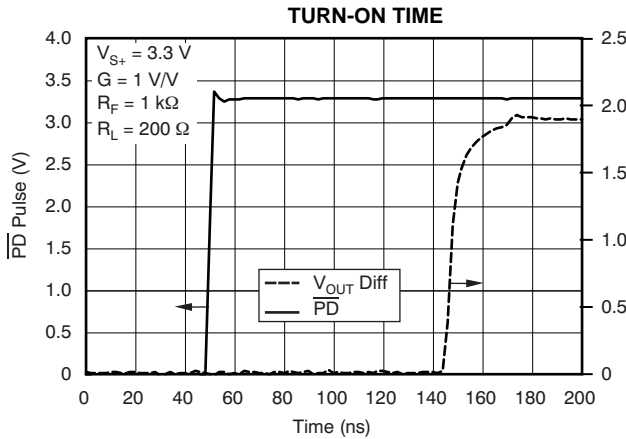


Figure 20.

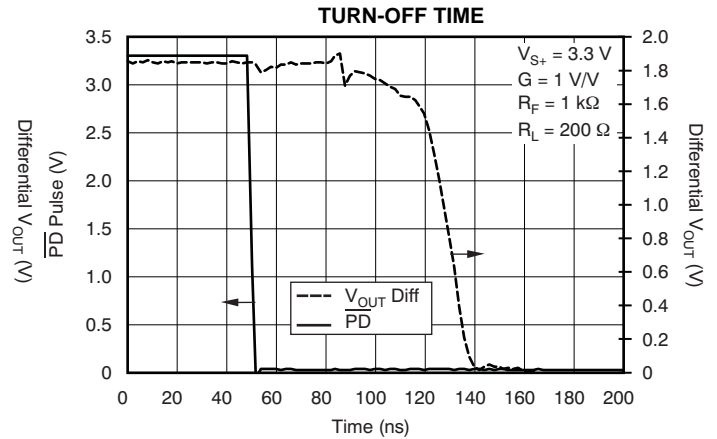


Figure 21.

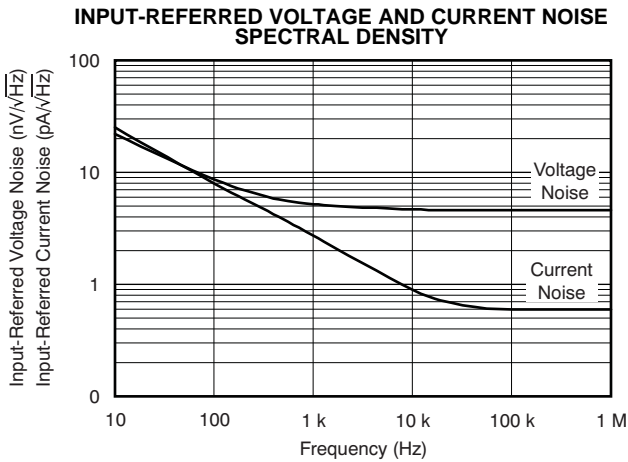


Figure 22.

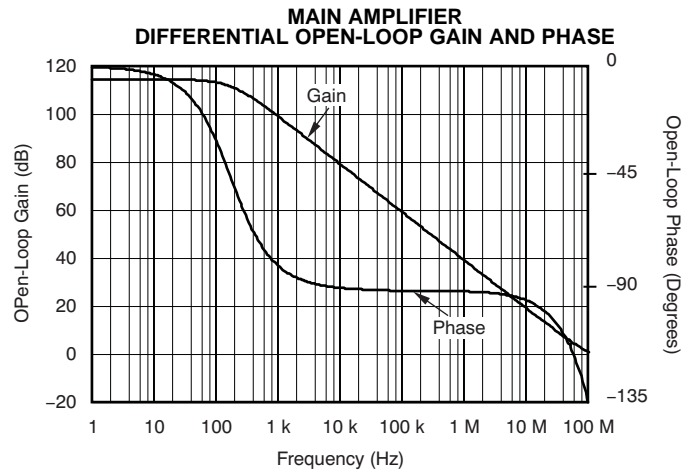


Figure 23.

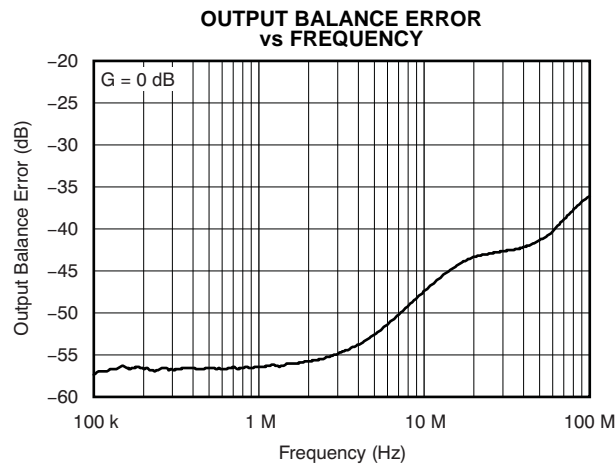


Figure 24.

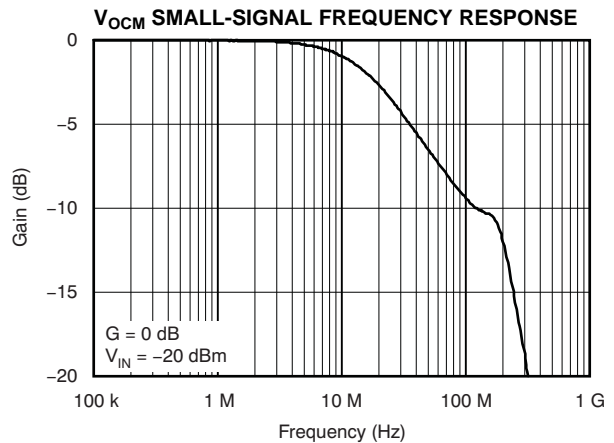
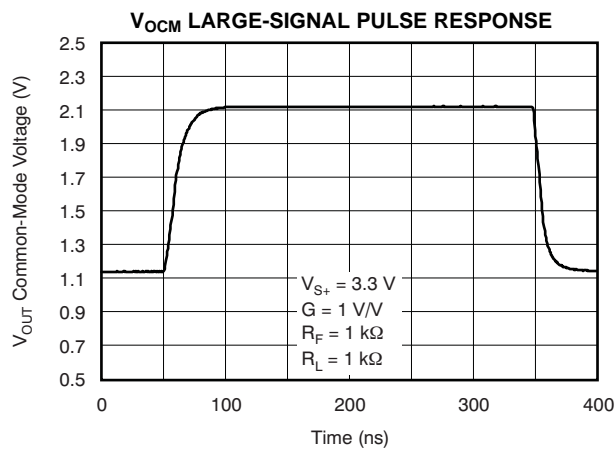
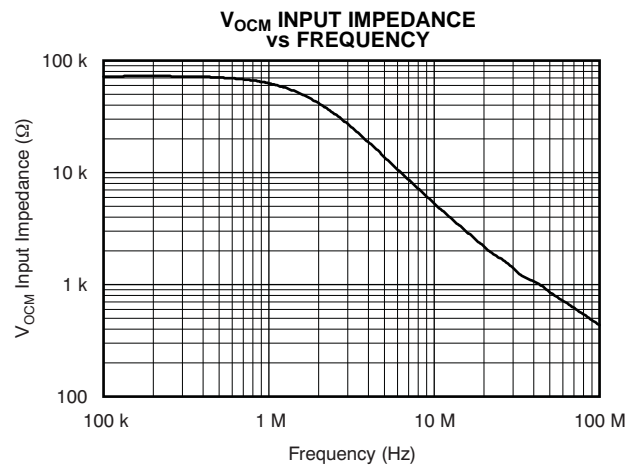


Figure 25.

**TYPICAL CHARACTERISTICS:  $V_{S+} - V_{S-} = 3.3\text{ V}$  (continued)**

At  $V_{S+} = +3.3\text{ V}$ ,  $V_{S-} = 0\text{ V}$ ,  $V_{OCM} = \text{open}$ ,  $V_{OUT} = 2\text{ V}_{PP}$  (differential),  $R_L = 1\text{ k}\Omega$  differential,  $G = 1\text{ V/V}$ , single-ended input, differential output, and input and output referenced to midsupply, unless otherwise noted.


**Figure 26.**

**Figure 27.**

**TYPICAL CHARACTERISTICS: 5 V**

At  $V_{S+} = +5\text{ V}$ ,  $V_{S-} = 0\text{ V}$ ,  $V_{OCM} = \text{open}$ ,  $V_{OUT} = 2\text{ V}_{PP}$  (differential),  $R_F = 1\text{ k}\Omega$ ,  $R_L = 1\text{ k}\Omega$  differential,  $G = 1\text{ V/V}$ , single-ended input, differential output, and input and output referenced to midsupply, unless otherwise noted.

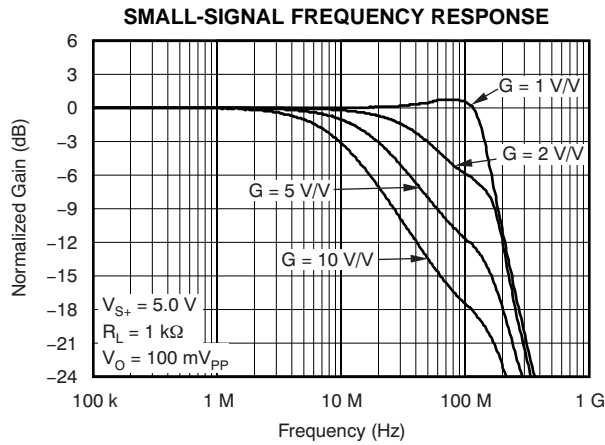


Figure 28.

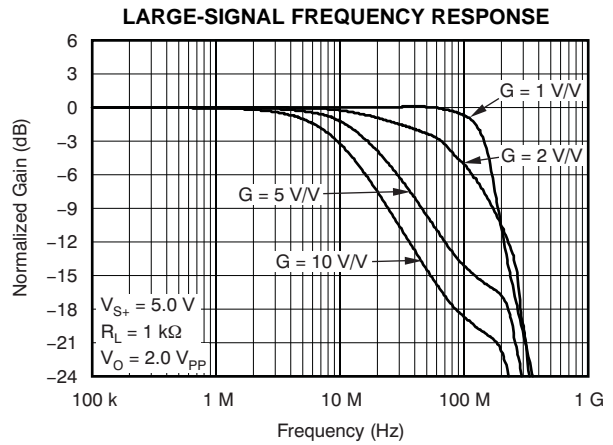


Figure 29.

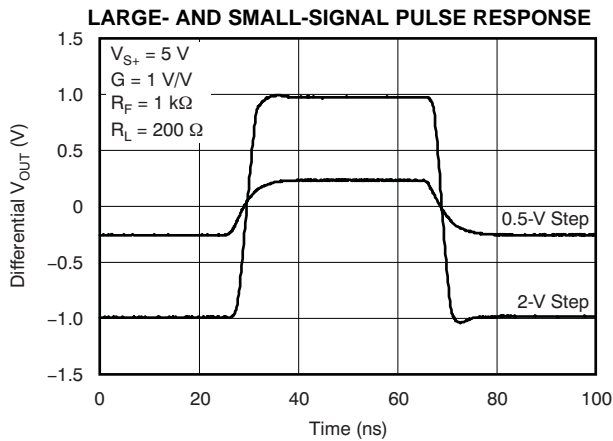


Figure 30.

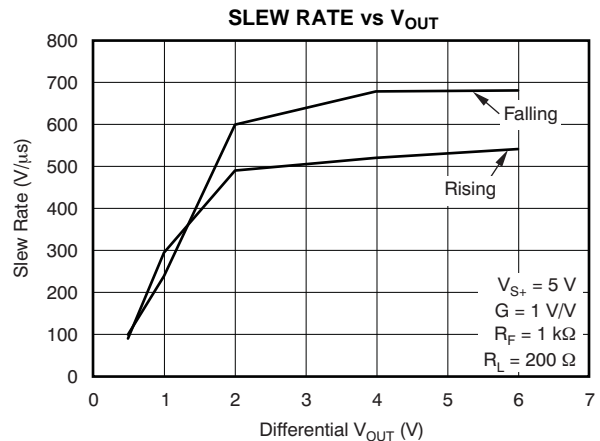


Figure 31.

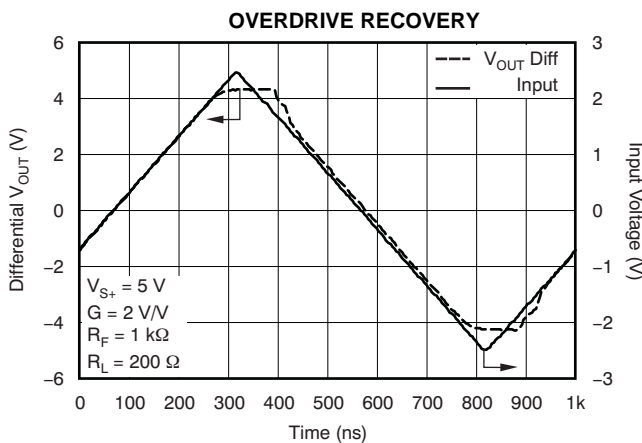


Figure 32.

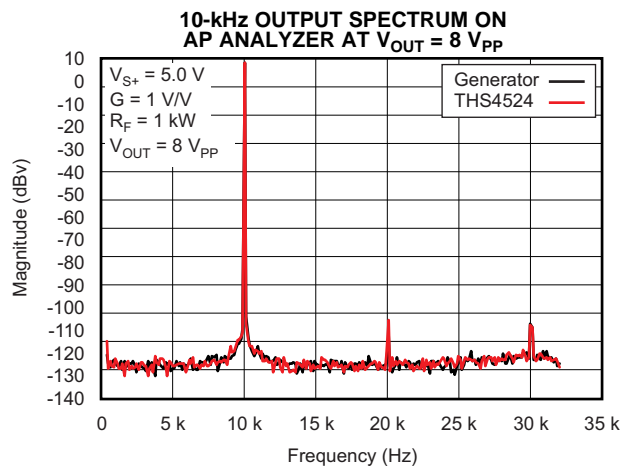


Figure 33.

**TYPICAL CHARACTERISTICS: 5 V (continued)**

At  $V_{S+} = +5\text{ V}$ ,  $V_{S-} = 0\text{ V}$ ,  $V_{OCM} = \text{open}$ ,  $V_{OUT} = 2\text{ V}_{PP}$  (differential),  $R_F = 1\text{ k}\Omega$ ,  $R_L = 1\text{ k}\Omega$  differential,  $G = 1\text{ V/V}$ , single-ended input, differential output, and input and output referenced to midsupply, unless otherwise noted.

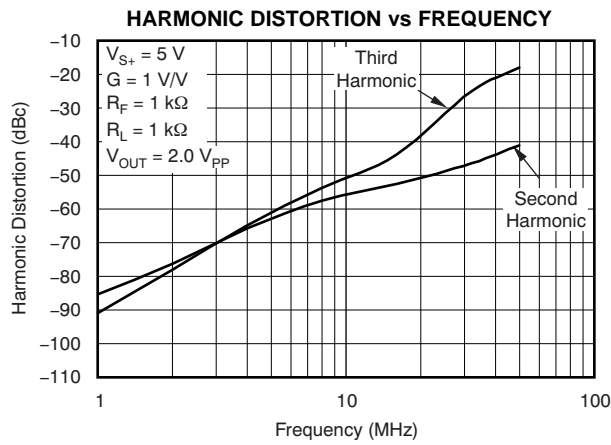


Figure 34.

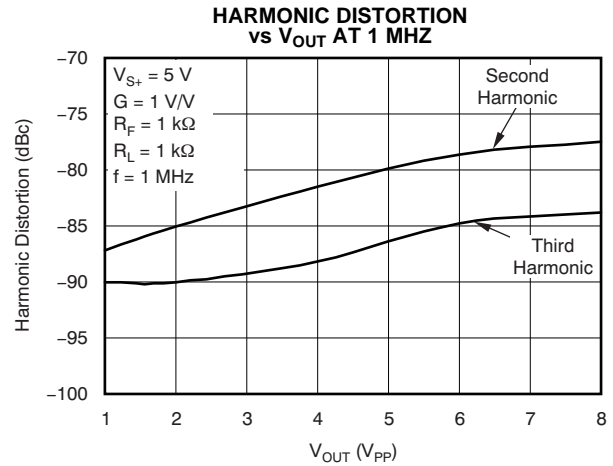


Figure 35.

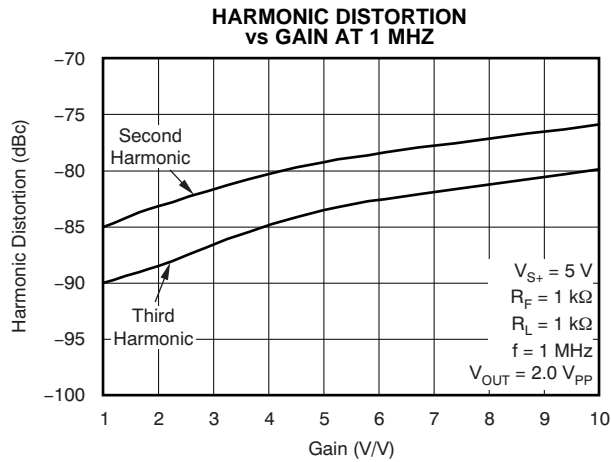


Figure 36.

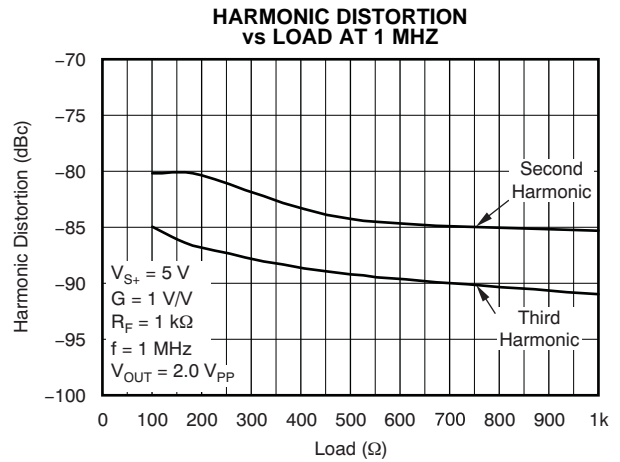


Figure 37.

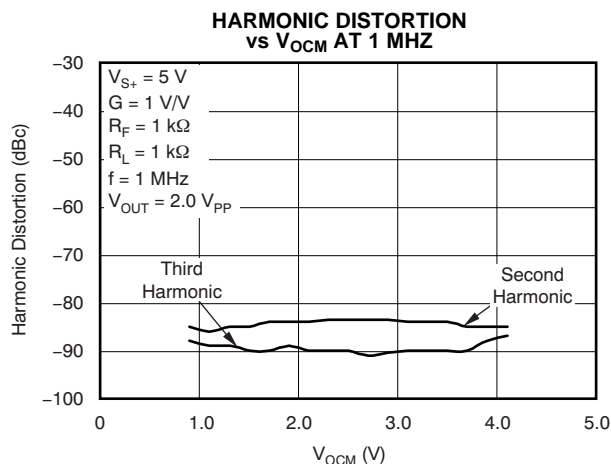


Figure 38.

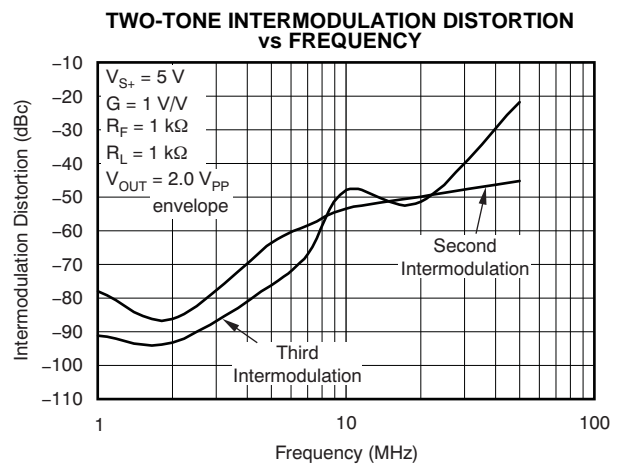


Figure 39.

**TYPICAL CHARACTERISTICS: 5 V (continued)**

At  $V_{S+} = +5\text{ V}$ ,  $V_{S-} = 0\text{ V}$ ,  $V_{OCM} = \text{open}$ ,  $V_{OUT} = 2\text{ V}_{PP}$  (differential),  $R_F = 1\text{ k}\Omega$ ,  $R_L = 1\text{ k}\Omega$  differential,  $G = 1\text{ V/V}$ , single-ended input, differential output, and input and output referenced to midsupply, unless otherwise noted.

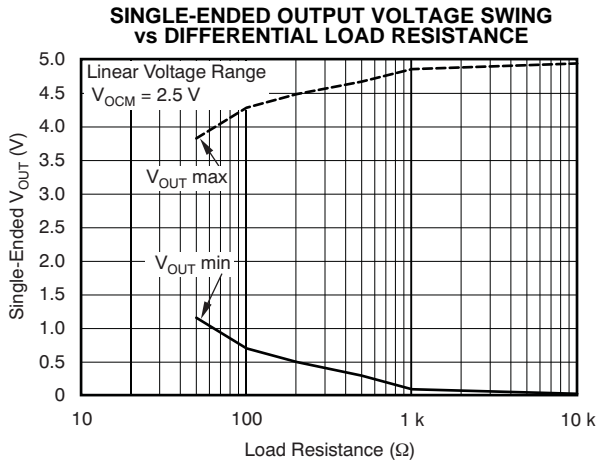


Figure 40.

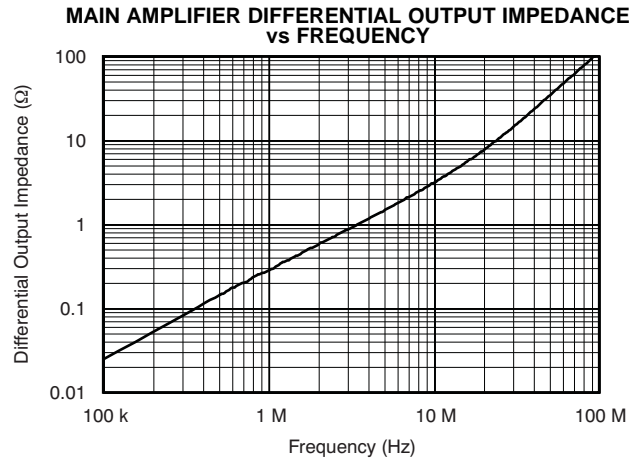


Figure 41.

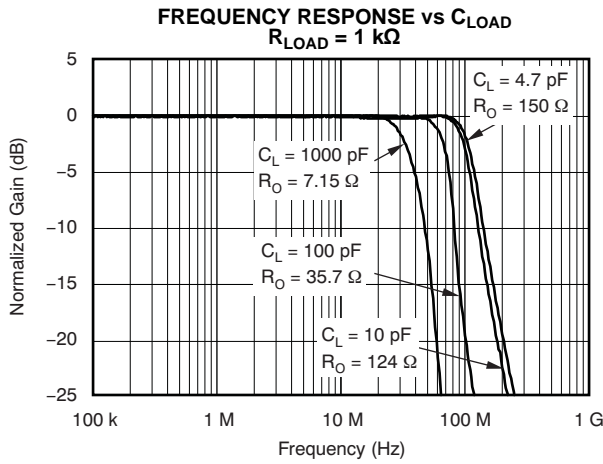


Figure 42.

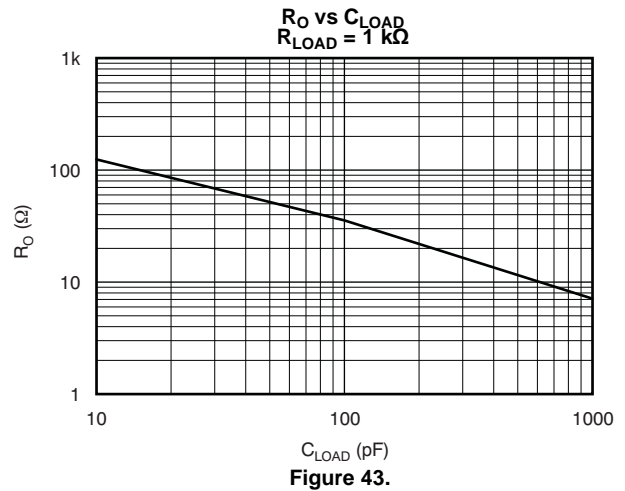


Figure 43.

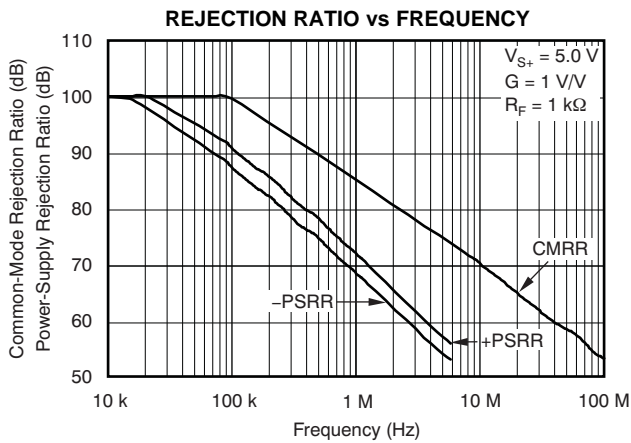


Figure 44.

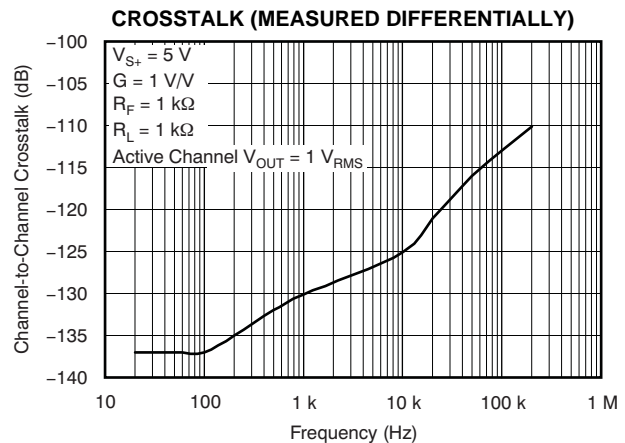


Figure 45.

**TYPICAL CHARACTERISTICS: 5 V (continued)**

At  $V_{S+} = +5\text{ V}$ ,  $V_{S-} = 0\text{ V}$ ,  $V_{OCM} = \text{open}$ ,  $V_{OUT} = 2\text{ V}_{PP}$  (differential),  $R_F = 1\text{ k}\Omega$ ,  $R_L = 1\text{ k}\Omega$  differential,  $G = 1\text{ V/V}$ , single-ended input, differential output, and input and output referenced to midsupply, unless otherwise noted.

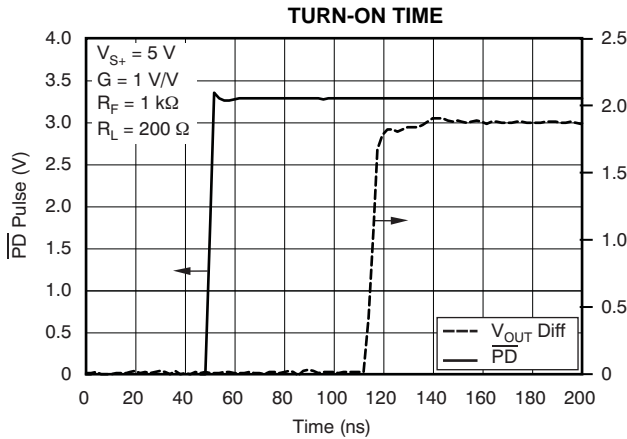


Figure 46.

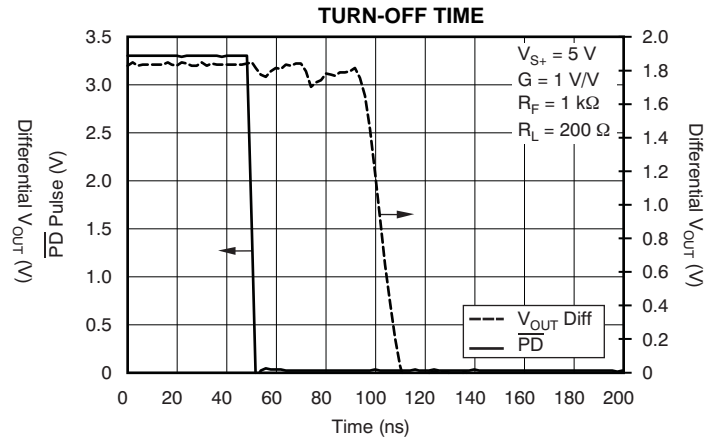


Figure 47.

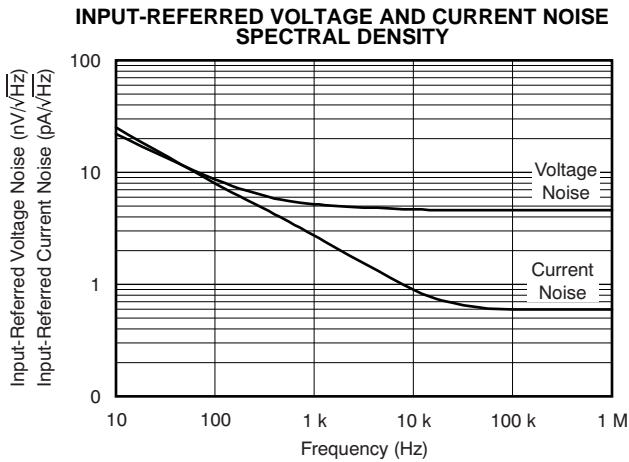


Figure 48.

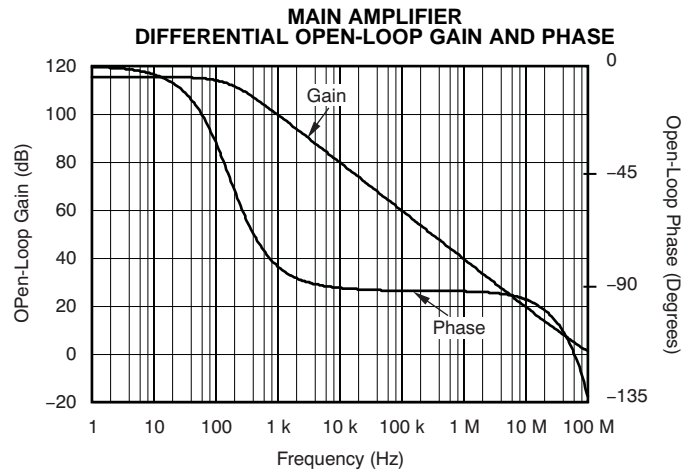


Figure 49.

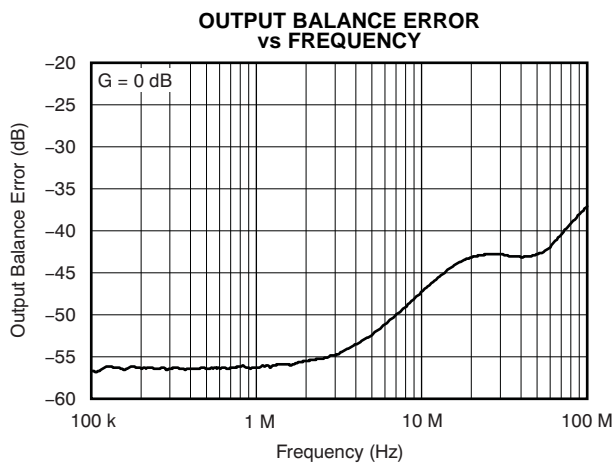


Figure 50.

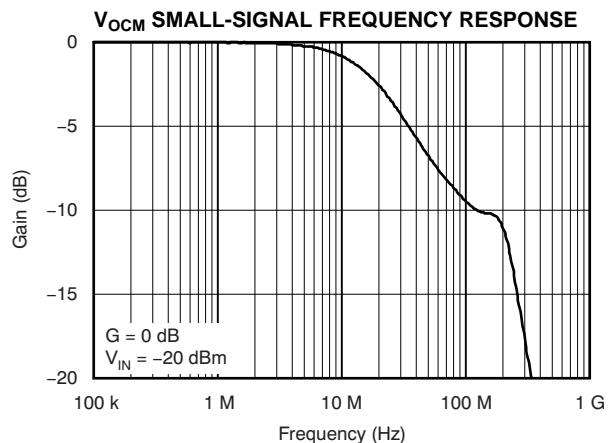
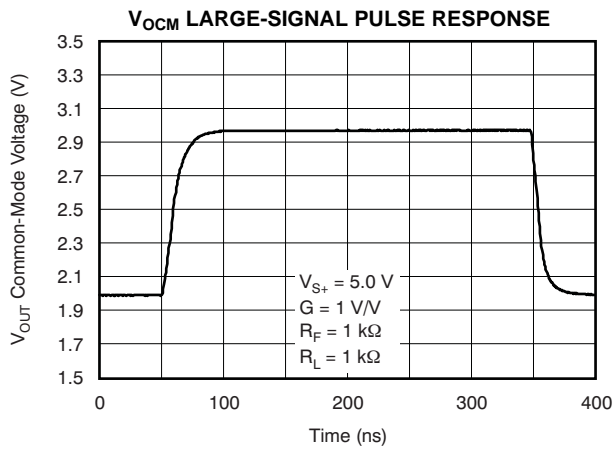


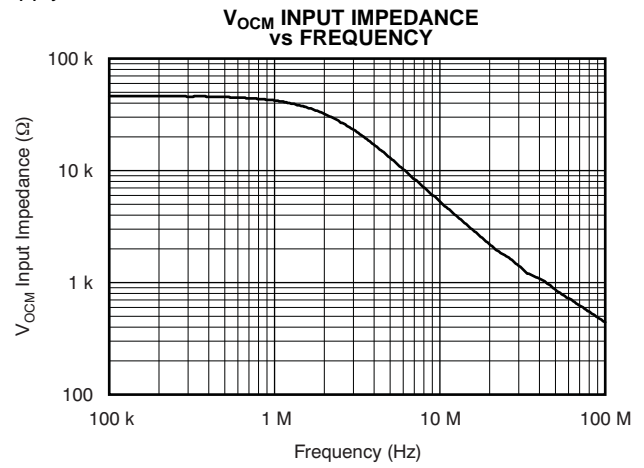
Figure 51.

**TYPICAL CHARACTERISTICS: 5 V (continued)**

At  $V_{S+} = +5\text{ V}$ ,  $V_{S-} = 0\text{ V}$ ,  $V_{OCM} = \text{open}$ ,  $V_{OUT} = 2\text{ V}_{PP}$  (differential),  $R_F = 1\text{ k}\Omega$ ,  $R_L = 1\text{ k}\Omega$  differential,  $G = 1\text{ V/V}$ , single-ended input, differential output, and input and output referenced to midsupply, unless otherwise noted.



**Figure 52.**



**Figure 53.**

## TEST CIRCUITS

### Overview

The THS4524 is tested with the test circuits shown in this section; all circuits are built using the available THS4524 evaluation module (EVM). For simplicity, power-supply decoupling is not shown; see the layout in the [Applications](#) section for recommendations. Depending on the test conditions, component values change in accordance with [Table 1](#) and [Table 2](#), or as otherwise noted. In some cases the signal generators used are ac-coupled and in others they dc-coupled 50-Ω sources. To balance the amplifier when ac-coupled, a 0.22-μF capacitor and 49.9-Ω resistor to ground are inserted across  $R_{IT}$  on the alternate input; when dc-coupled, only the 49.9-Ω resistor to ground is added across  $R_{IT}$ . A split power supply is used to ease the interface to common test equipment, but the amplifier can be operated in a single-supply configuration as described in the [Applications](#) section with no impact on performance. Also, for most of the tests, except as noted, the devices are tested with single-ended inputs and a transformer on the output to convert the differential output to single-ended because common lab test equipment has single-ended inputs and outputs. Similar or better performance can be expected with differential inputs and outputs.

As a result of the voltage divider on the output formed by the load component values, the amplifier output is attenuated. The **Atten** column in [Table 2](#) shows the attenuation expected from the resistor divider. When using a transformer at the output (as shown in [Figure 55](#)), the signal sees slightly more loss because of transformer and line loss; these numbers are approximate.

**Table 1. Gain Component Values for Single-Ended Input<sup>(1)</sup>**

Gain	$R_F$	$R_G$	$R_{IT}$
1 V/V	1 kΩ	1 kΩ	52.3 Ω
2 V/V	1 kΩ	487 Ω	53.6 Ω
5 V/V	1 kΩ	187 Ω	59.0 Ω
10 V/V	1 kΩ	86.6 Ω	69.8 Ω

- Gain setting includes 50-Ω source impedance. Components are chosen to achieve gain and 50-

Ω input termination.

**Table 2. Load Component Values For 1:1 Differential to Single-Ended Output Transformer<sup>(1)</sup>**

$R_L$	$R_O$	$R_{OT}$	Atten
100 Ω	24.9 Ω	Open	6 dB
200 Ω	86.6 Ω	69.8 Ω	16.8 dB
499 Ω	237 Ω	56.2 Ω	25.5 dB
1 kΩ	487 Ω	52.3 Ω	31.8 dB

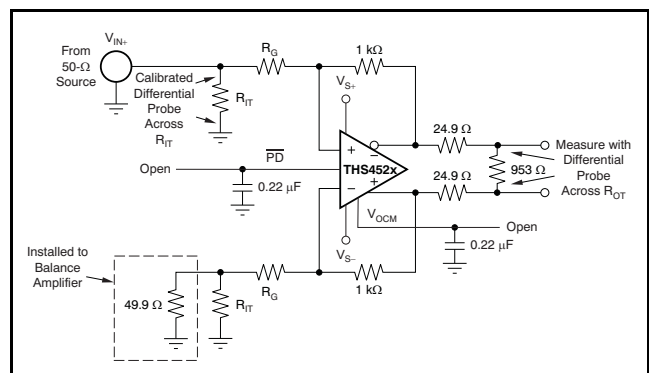
- Total load includes 50-Ω termination by the test equipment. Components are chosen to achieve load and 50-Ω line termination through a 1:1 transformer.

### Frequency Response

The circuit shown in [Figure 54](#) is used to measure the frequency response of the circuit.

An HP network analyzer is used as the signal source and the measurement device. The output impedance of the HP network analyzer is dc-coupled and is 50 Ω.  $R_{IT}$  and  $R_G$  are chosen to impedance-match to 50 Ω and maintain the proper gain. To balance the amplifier, a 49.9-Ω resistor to ground is inserted across  $R_{IT}$  on the alternate input.

The output is probed using a Tektronix high-impedance differential probe across the 953-Ω resistor and referred to the amplifier output by adding back the 0.42-dB because of the voltage divider on the output.



**Figure 54. Frequency Response Test Circuit**



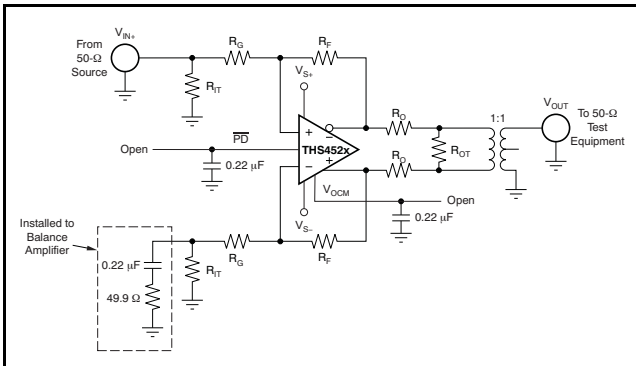
**Distortion**

The circuit shown in Figure 55 is used to measure harmonic and intermodulation distortion of the amplifier.

An HP signal generator is used as the signal source and the output is measured with a Rhode and Schwarz spectrum analyzer. The output impedance of the HP signal generator is ac-coupled and is 50 Ω.  $R_{IT}$  and  $R_G$  are chosen to impedance match to 50 Ω and maintain the proper gain. To balance the amplifier, a 0.22-μF capacitor and 49.9-Ω resistor to ground are inserted across  $R_{IT}$  on the alternate input.

A low-pass filter is inserted in series with the input to reduce harmonics generated at the signal source. The level of the fundamental is measured and then a high-pass filter is inserted at the output to reduce the fundamental so it does not generate distortion in the input of the spectrum analyzer.

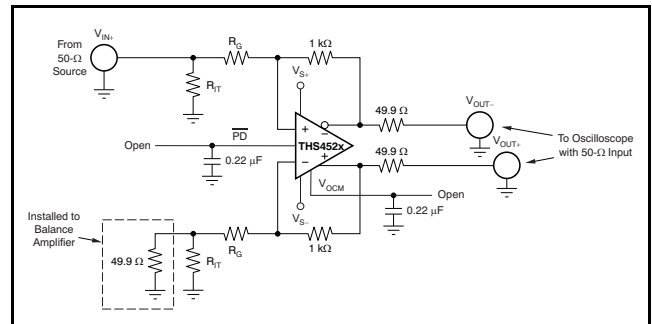
The transformer used in the output to convert the signal from differential to single-ended is an ADT1-1WT. It limits the frequency response of the circuit so that measurements cannot be made below approximately 1 MHz.



**Figure 55. Distortion Test Circuit**

**Slew Rate, Transient Response, Settling Time, Output Impedance, Overdrive, Output Voltage, and Turn-On/Turn-Off Time**

The circuit shown in Figure 56 is used to measure slew rate, transient response, settling time, output impedance, overdrive recovery, output voltage swing, and amplifier turn-on/turn-off time. Turn-on and turn-off time are measured with the same circuit modified for 50-Ω input impedance on the PD input by replacing the 0.22-μF capacitor with a 49.9-Ω resistor. For output impedance, the signal is injected at  $V_{OUT}$  with  $V_{IN}$  open; the drop across the 2x 49.9-Ω resistors is then used to calculate the impedance seen looking into the amplifier output.



**Figure 56. Slew Rate, Transient Response, Settling Time, Output Impedance, Overdrive Recovery,  $V_{OUT}$  Swing, and Turn-On/Turn-Off Test Circuit**

### Common-Mode and Power-Supply Rejection

The circuit shown in Figure 57 is used to measure the CMRR. The signal from the network analyzer is applied common-mode to the input. Figure 58 is used to measure the PSRR of  $V_{S+}$  and  $V_{S-}$ . The power supply under test is applied to the network analyzer dc offset input. For both CMRR and PSRR, the output is probed using a Tektronix high-impedance differential probe across the 953- $\Omega$  resistor and referred to the amplifier output by adding back the 0.42-dB as a result of the voltage divider on the output. For these tests, the resistors are matched for best results.

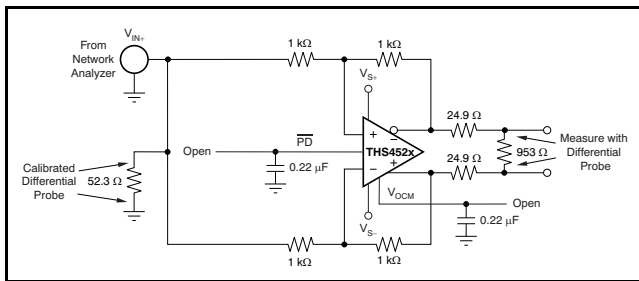


Figure 57. CMRR Test Circuit

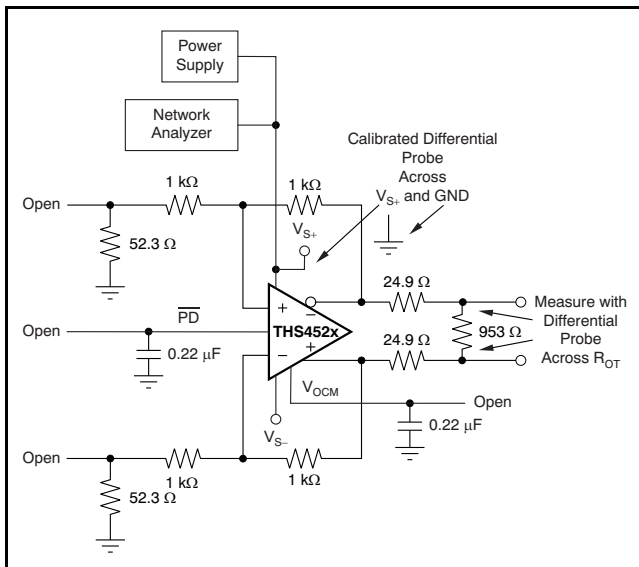


Figure 58. PSRR Test Circuit

### $V_{OCM}$ Input

The circuit illustrated in Figure 59 is used to measure the frequency response and input impedance of the  $V_{OCM}$  input. Frequency response is measured using a Tektronix high-impedance differential probe, with  $R_{CM} = 0 \Omega$  at the common point of  $V_{OUT+}$  and  $V_{OUT-}$ , formed at the summing junction of the two matched 499- $\Omega$  resistors, with respect to ground. The input impedance is measured using a Tektronix high-impedance differential probe at the  $V_{OCM}$  input with  $R_{CM} = 10 \text{ k}\Omega$  and the drop across the 10-k $\Omega$  resistor is used to calculate the impedance seen looking into the amplifier  $V_{OCM}$  input.

The circuit shown in Figure 60 measures the transient response and slew rate of the  $V_{OCM}$  input. A 1-V step input is applied to the  $V_{OCM}$  input and the output is measured using a 50- $\Omega$  oscilloscope input referenced back to the amplifier output.

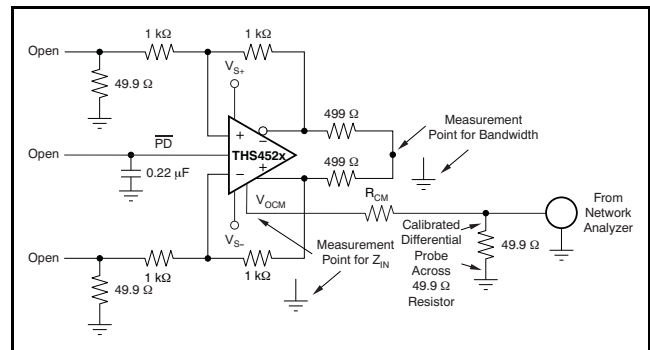


Figure 59.  $V_{OCM}$  Input Test Circuit

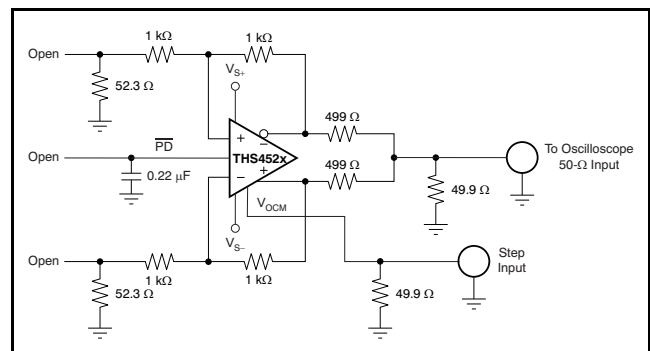


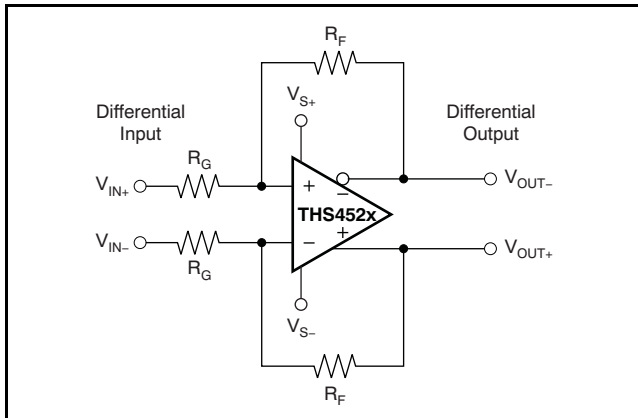
Figure 60.  $V_{OCM}$  Transient Response and Slew Rate Test Circuit

## APPLICATION INFORMATION

The following circuits show application information for the THS4524. For simplicity, power-supply decoupling capacitors are not shown in these diagrams; see the [EVM and Layout Recommendations](#) section for suggested guidelines. For more details on the use and operation of fully differential op amps, refer to the Application Report [Fully-Differential Amplifiers \(SLOA054\)](#), available for download from the TI web site at [www.ti.com](http://www.ti.com).

### Differential Input to Differential Output Amplifier

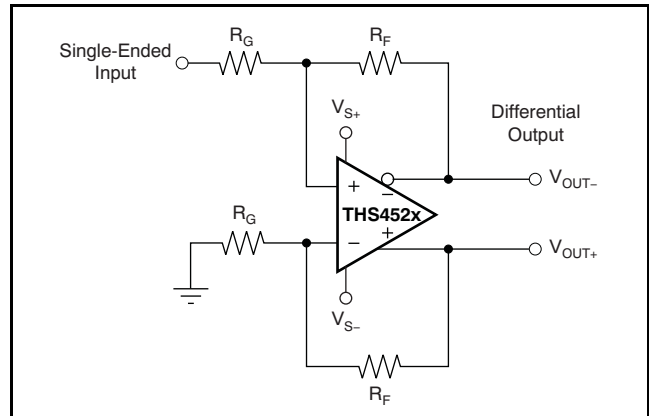
The THS4524 is a fully-differential operational amplifier that can be used to amplify differential input signals to differential output signals. [Figure 61](#) shows a basic block diagram of the circuit ( $V_{OCM}$  and  $\overline{PD}$  inputs not shown). The gain of the circuit is set by  $R_F$  divided by  $R_G$ .



**Figure 61. Differential Input to Differential Output Amplifier**

### Single-Ended Input to Differential Output Amplifier

The THS4524 can also amplify and convert single-ended input signals to differential output signals. [Figure 62](#) illustrates a basic block diagram of the circuit ( $V_{OCM}$  and  $\overline{PD}$  inputs not shown). The gain of the circuit is again set by  $R_F$  divided by  $R_G$ .



**Figure 62. Single-Ended Input to Differential Output Amplifier**

### Input Common-Mode Voltage Range

The input common-mode voltage of a fully-differential op amp is the voltage at the + and – input pins of the device.

It is important to not violate the input common-mode voltage range ( $V_{ICR}$ ) of the op amp. Assuming the op amp is in linear operation, the voltage across the input pins is only a few millivolts at most. Therefore, finding the voltage at one input pin determines the input common-mode voltage of the op amp.

Treating the negative input as a summing node, the voltage is given by [Equation 1](#):

$$\left( V_{OUT+} \times \frac{R_G}{R_G + R_F} \right) + \left( V_{IN-} \times \frac{R_F}{R_G + R_F} \right) \quad (1)$$

To determine the  $V_{ICR}$  of the op amp, the voltage at the negative input is evaluated at the extremes of  $V_{OUT+}$ . As the gain of the op amp increases, the input common-mode voltage becomes closer and closer to the input common-mode voltage of the source.

### Setting the Output Common-Mode Voltage

The output common-mode voltage is set by the voltage at the  $V_{OCM}$  pin. The internal common-mode control circuit maintains the output common-mode voltage within 5-mV offset (typ) from the set voltage. If left unconnected, the common-mode set point is set to midsupply by internal circuitry, which may be overdriven from an external source.

# THS4524-EP

ZHCS944A – JUNE 2012 – REVISED AUGUST 2013

www.ti.com.cn

Figure 63 represents the  $V_{OCM}$  input. The internal  $V_{OCM}$  circuit has typically 23 MHz of  $-3$  dB bandwidth, which is required for best performance, but it is intended to be a dc bias input pin. A  $0.22\text{-}\mu\text{F}$  bypass capacitor is recommended on this pin to reduce noise. The external current required to overdrive the internal resistor divider is given approximately by the formula in Equation 2:

$$I_{EXT} = \frac{2V_{OCM} - (V_{S+} - V_{S-})}{50\text{ k}\Omega}$$

where:

- $V_{OCM}$  is the voltage applied to the  $V_{OCM}$  pin (2)

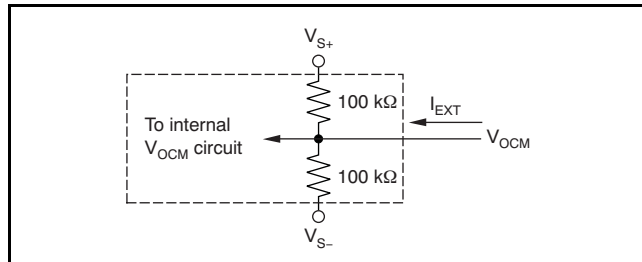


Figure 63.  $V_{OCM}$  Input Circuit

## Typical Performance Variation with Supply Voltage

The THS4524 provides excellent performance across the specified power-supply range of 2.5 V to 5.5 V with only minor variations. The input and output voltage compliance ranges track with the power supply in nearly a 1:1 correlation. Other changes can be observed in slew rate, output current drive, open-loop gain, bandwidth, and distortion. Table 3 shows the typical variation to be expected in these key performance parameters.

Table 3. Typical Performance Variation versus Power-Supply Voltage

PARAMETER	$V_S = 5\text{ V}$	$V_S = 3.3\text{ V}$	$V_S = 2.5\text{ V}$
$-3$ -dB Small-signal bandwidth	145 MHz	135 MHz	125 MHz
Slew rate (2-V step)	490 V/ $\mu$ s	420 V/ $\mu$ s	210 V/ $\mu$ s
Harmonic distortion at 1 MHz, $2 V_{PP}$ , $R_L = 1\text{ k}\Omega$			
Second harmonic	$-85$ dBc	$-85$ dBc	$-84$ dBc
Third harmonic	$-91$ dBc	$-90$ dBc	$-88$ dBc
Open-loop gain	119 dB	116 dB	115 dB
Linear output current drive	55 mA	35 mA	24 mA

## Single-Supply Operation

To facilitate testing with common lab equipment, the THS4524EVM allows for split-supply operation; most of the characterization data presented in this data sheet is measured using split-supply power inputs. The device can easily be used with a single-supply power input without degrading performance.

Figure 64 shows a dc-coupled single-supply circuit with single-ended inputs. This circuit can also be applied to differential input sources.

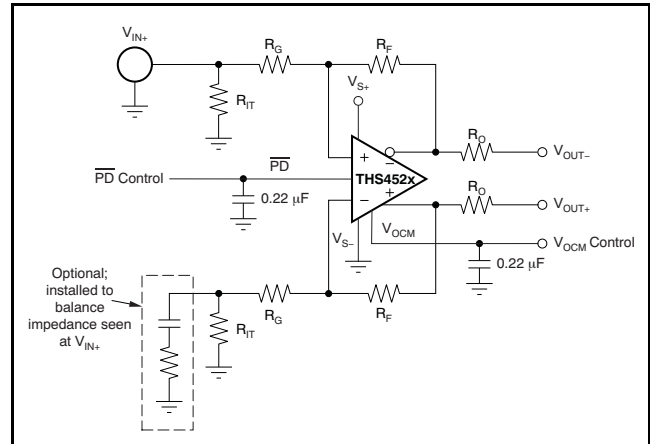


Figure 64. THS4524 DC-Coupled Single-Supply with Single-Ended Inputs

The input common-mode voltage range of the THS4524 is designed to include the negative supply voltage. In the circuit shown in Figure 64, the signal source is referenced to ground.  $V_{OCM}$  is set by an external control source or, if left unconnected, the internal circuit defaults to midsupply. Together with the input impedance of the amplifier circuit,  $R_{IT}$  provides input termination, which is also referenced to ground.

Note that  $R_{IT}$  and optional matching components are added to the alternate input to balance the impedance at signal input.

### Low-Power Applications and the Effects of Resistor Values on Bandwidth

For low-power operation, it may be necessary to increase the gain setting resistors values to limit current consumption and not load the source. Using larger value resistors lowers the bandwidth of the THS4524 as a result of the interactions between the resistors, the device parasitic capacitance, and printed circuit board (PCB) parasitic capacitance. Figure 65 shows the small-signal frequency response with 1-k $\Omega$ , 10-k $\Omega$ , and 100-k $\Omega$  resistors for R<sub>F</sub>, R<sub>G</sub>, and R<sub>L</sub> (impedance is assumed to typically increase for all three resistors in low-power applications).

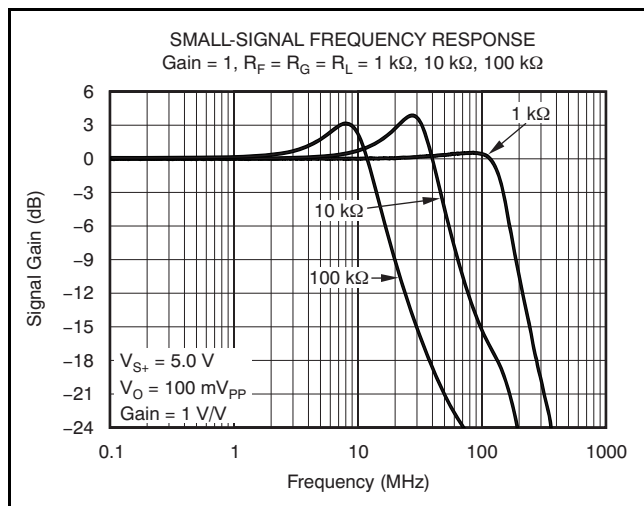


Figure 65. THS4524 Frequency Response with Various Gain Setting and Load Resistor Values

### Frequency Response Variation due to Package Options

Users can see variations in the small-signal (V<sub>OUT</sub> = 100 mV<sub>PP</sub>) frequency response between the available package options for the THS452x family as a result of parasitic elements associated with each package and board layout changes. Figure 66 shows the variance measured in the lab; this variance is to be expected even when using a good layout.

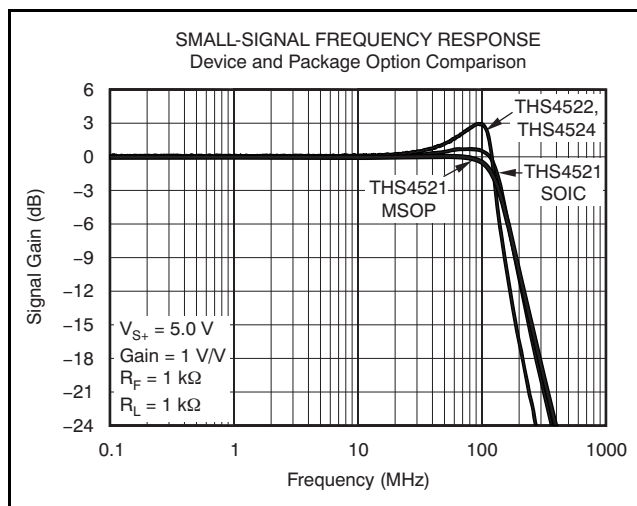


Figure 66. Small-Signal Frequency Response: Package Variations

# THS4524-EP

ZHCS944A – JUNE 2012 – REVISED AUGUST 2013

www.ti.com.cn

## Driving Capacitive Loads

The THS4524 is designed for a nominal capacitive load of 1 pF on each output to ground. When driving capacitive loads greater than 1 pF, it is recommended to use small resistors ( $R_O$ ) in series with the output, placed as close to the device as possible. Without  $R_O$ , capacitance on the output interacts with the output impedance of the amplifier and causes phase shift in the loop gain of the amplifier that reduces the phase margin. This reduction in phase margin results in frequency response peaking; overshoot, undershoot, and/or ringing when a step or square-wave signal is applied; and may lead to instability or oscillation. Inserting  $R_O$  isolates the phase shift from the loop gain path and restores the phase margin, but it also limits bandwidth. Figure 67 shows the recommended values of  $R_O$  versus capacitive loads ( $C_L$ ), and Figure 68 shows an illustration of the frequency response with various values.

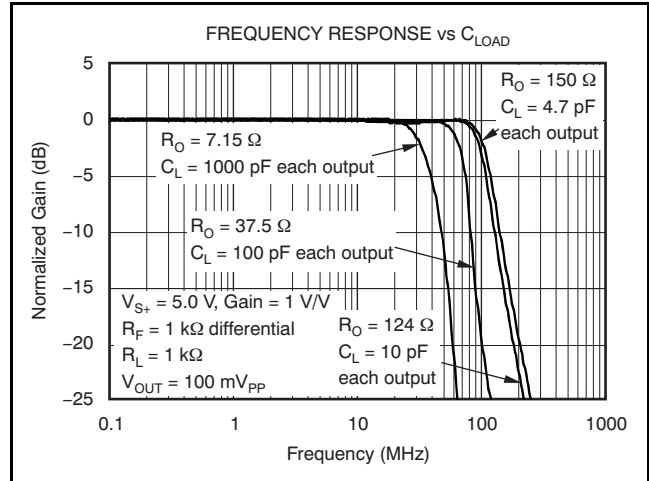


Figure 68. Frequency Response for Various  $R_O$  and  $C_L$  Values, with  $R_{LOAD} = 1\text{ k}\Omega$

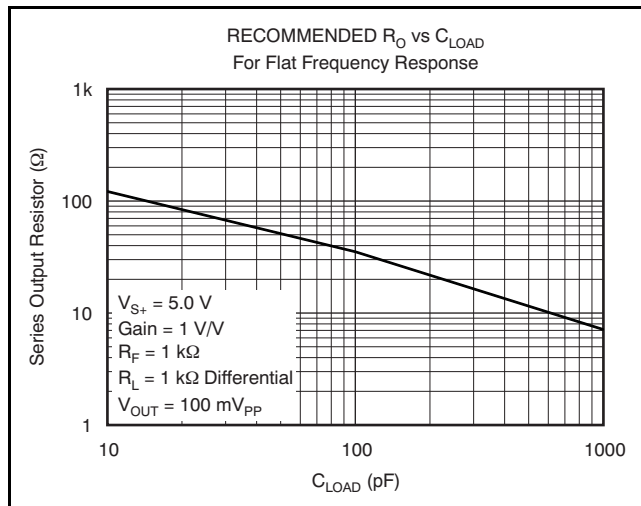


Figure 67. Recommended Series Output Resistor versus Capacitive Load for Flat Frequency Response, with  $R_{LOAD} = 1\text{ k}\Omega$

## Audio Performance

The THS4524 provides excellent audio performance with very low quiescent power. To show performance in the audio band, the device was tested with a SYS-2722 audio analyzer from Audio Precision. THD+N and FFT tests were performed at  $1\text{-}V_{RMS}$  output voltage. Performance is the same on both 3.3-V and 5-V supplies. Figure 69 shows the test circuit used; see Figure 70 and Figure 71 for the performance of the analyzer using internal loopback mode (generator) together with the THS4524.

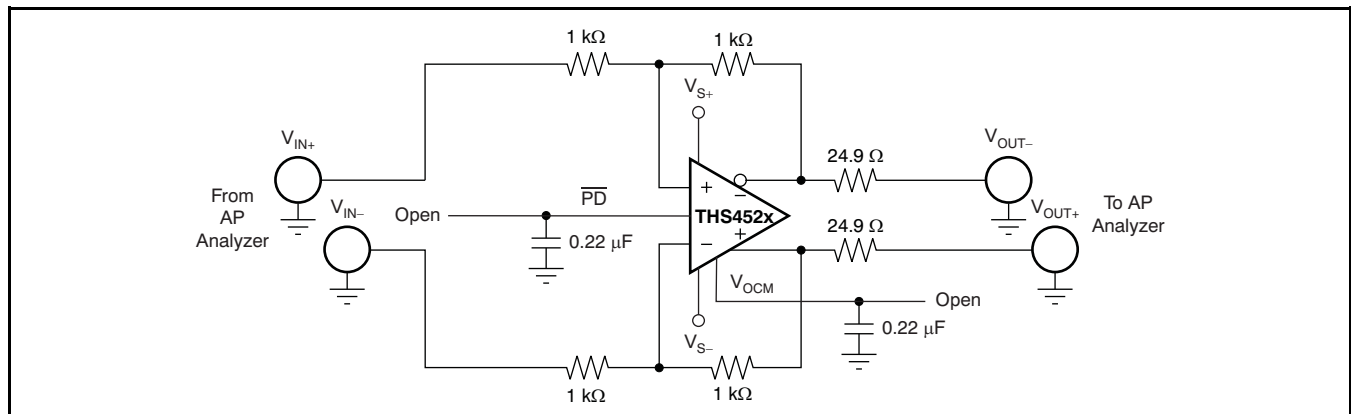


Figure 69. THS4524 AP Analyzer Test Circuit

Note that the harmonic distortion performance is very close to the same with and without the device meaning the THS4524 performance is actually much better than can be directly measured by this method. The actual device performance can be estimated by placing the device in a large noise gain and using the reduction in loop gain correction. The THS4524 is placed in a noise gain of 101 by adding a 10-Ω resistor directly across the input terminals of the circuit shown in Figure 69. This test was performed using the AP instrument as both the signal source and the analyzer. The second-order harmonic distortion at 1 kHz is estimated to be -122 dBc with  $V_O = 1V_{RMS}$ ; third-order harmonic distortion is estimated to be -141 dBc. The third-order harmonic distortion result matches exactly with design simulations, but the second-order harmonic distortion is about 10 dB worse. This result is not unexpected because second-order harmonic distortion performance with a differential signal depends heavily on cancellation as a result of the differential nature of the signal, which depends on board layout, bypass capacitors, external cabling, and so forth. Note that the circuit of Figure 69 is also used to measure crosstalk between channels.

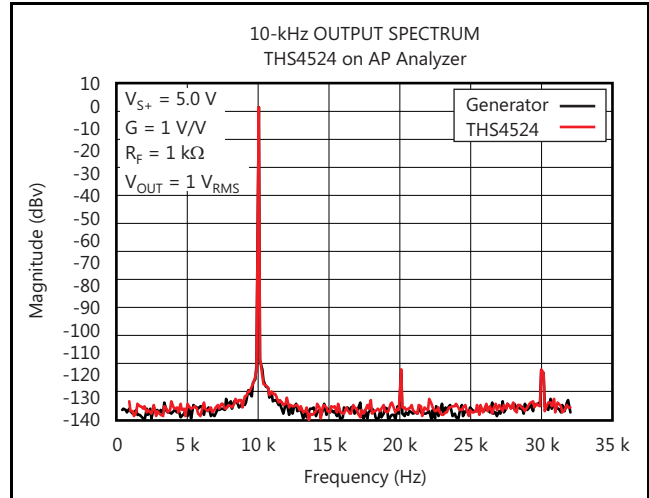


Figure 71. THS4524 1- $V_{RMS}$  10-kHz FFT Plot

The THS4524 shows even better THD+N performance when driving higher amplitude output, such as 5  $V_{PP}$  that is more typical when driving an ADC. To show performance with an extended frequency range, higher gain, and higher amplitude, the device was tested with 5  $V_{PP}$  up to 80 kHz with the AP. Figure 72 shows the resulting THD+N graph with no weighting.

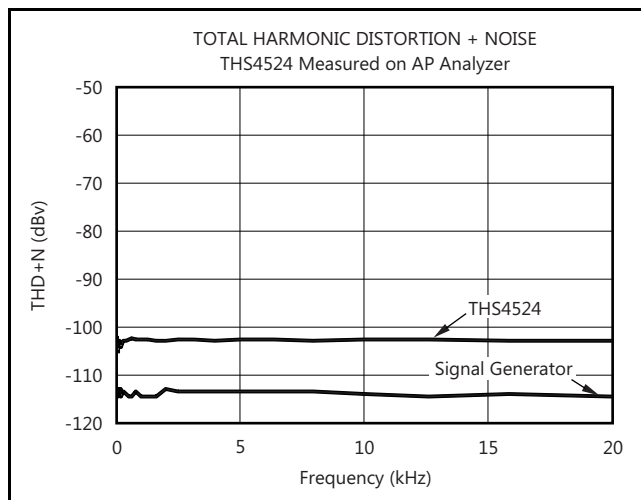


Figure 70. THS4524 1- $V_{RMS}$  20-Hz to 20-kHz THD+N

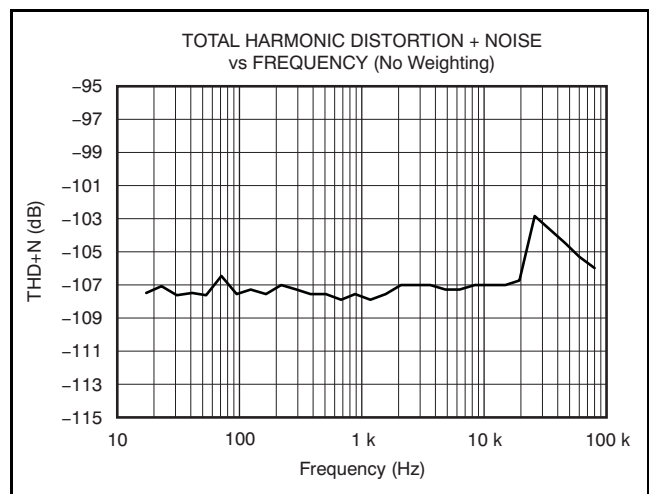


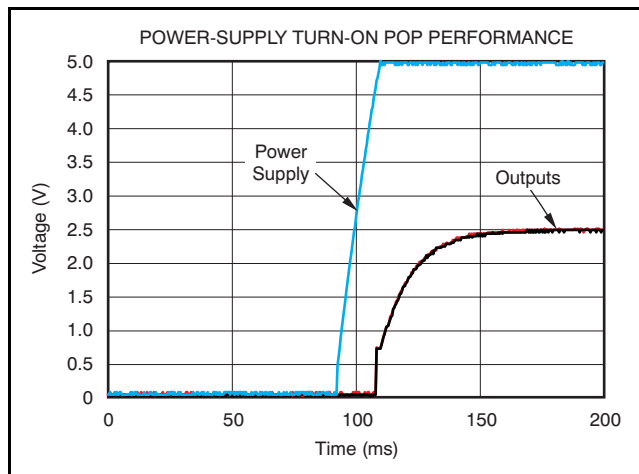
Figure 72. THD+N (No Weighting) on AP, 80-kHz Bandwidth at  $G = 1$  with 5- $V_{PP}$  Output



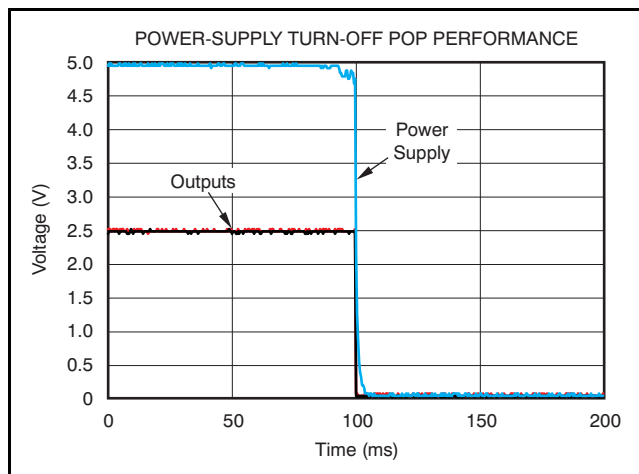
## Audio On/Off Pop Performance

The THS4524 was tested to show on and off pop performance by connecting a speaker between the differential outputs and switching the power supply on and off, and also by using the PD function of the THS4524. Testing was done with and without tones. During these tests, no audible pop could be heard.

With no tone input, Figure 73 shows the pop performance when switching power on to the THS4524 and Figure 74 shows the device performance when turning the power off. The transients during power on and off illustrate that no audible pop should be heard.

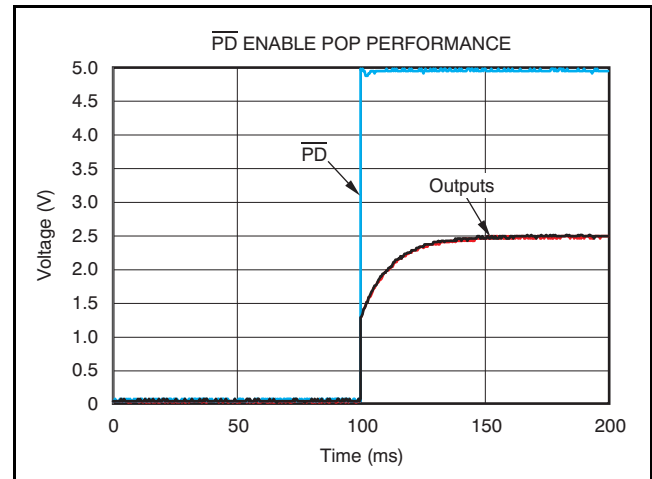


**Figure 73. THS4524 Power-Supply Turn-On Pop Performance**

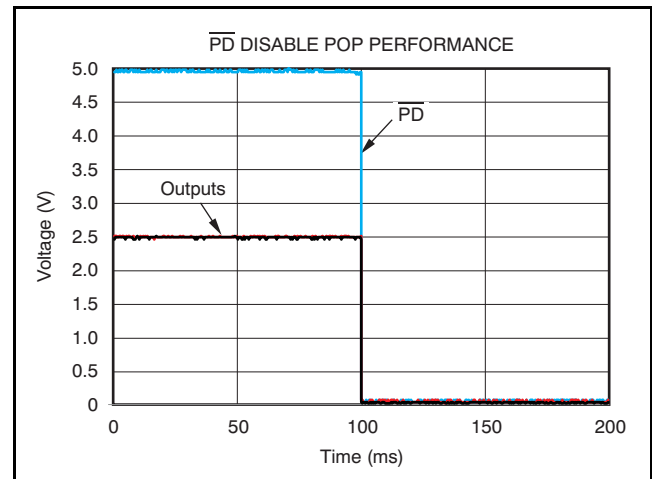


**Figure 74. THS4524 Power-Supply Turn-Off Pop Performance**

With no tone input, Figure 75 shows the pop performance using the PD pin to enable the THS4524, and Figure 76 shows performance using the PD pin to disable the device. Again, the transients during power on and off show that no audible pop should be heard. It should also be noted that the turn on/off times are faster using the PD pin technique.



**Figure 75. THS4524 PD Pin Enable Pop Performance**



**Figure 76. THS4524 PD Pin Disable Pop Performance**

The power on/off pop performance of the THS4524, whether by switching the power supply or when using the power-down function built into the chip, shows that no special design should be required to prevent an audible pop.



### Audio ADC Driver Performance: THS4524 and PCM4204 Combined Performance

To show achievable performance with a high-performance audio ADC, the THS4524 is tested as the drive amplifier for the PCM4204. The PCM4204 is a high-performance, four-channel ADC designed for professional and broadcast audio applications. The PCM4204 architecture uses a 1-bit delta-sigma ( $\Delta\Sigma$ ) modulator per channel that incorporates an advanced dither scheme for improved dynamic performance, and supports PCM output data. The PCM4204 provides a flexible serial port interface and many other advanced features. Refer to the [PCM4204 product data sheet](#) for more information.

The PCM4204EVM can test the audio performance of the THS4524 as a drive amplifier. The standard PCM4204EVM is provided with four OPA1632 fully-differential amplifiers, which use the same device pinout as the THS4524. For testing, one of these amplifiers is replaced with a THS4524 device in same package (MSOP), and the power supply changes to a single-supply +5V. [Figure 79](#) shows the modifications made to the circuit. Note the resistor connecting the  $V_{OCM}$  input of the THS4524 to the input common-mode drive from the PCM4204 is shown removed and is optional; no performance change was noted with it connected or removed. The THS4524 is operated with a +5-V single-supply so the output common-mode defaults to +2.5 V as required at the input of the PCM4204. The EVM power connections were modified by connecting positive supply inputs,

+15 V, +5 VA and +5 VD, to a +5-V external power supply (EXT +3.3 was not used) and connecting -15 V and all ground inputs to ground on the external power supply. Note only one external +5-V supply was needed to power all devices on the EVM.

A SYS-2722 Audio Analyzer from Audio Precision (AP) provides an analog audio input to the EVM; the PCM-formatted digital output is read by the digital input on the AP.

Data were taken using a 256- $f_s$  system clock to achieve  $f_s = 48$ -kHz measurements, and audio output uses PCM format. Other data rates and formats are expected to show similar performance in line with that shown in the product data sheet.

[Figure 77](#) shows the THD+N vs Frequency response with no weighting; [Figure 78](#) shows an FFT of the output with 1-kHz input tone. Input signals to the PCM4204 for these tests is 0.5 dBFS. Dynamic range is also tested at -60 dBFS,  $f_{IN} = 1$  kHz, and A-weighted. [Table 4](#) summarizes testing results using the THS4524 together with the PCM4204 versus typical data sheet performance measurements, and show that it make an excellent drive amplifier for this ADC.

The test circuit shown in [Figure 79](#) has a gain = 0.27 and attenuates the input signal. For applications that require higher gain, the circuit was modified to gains of  $G = 1$ ,  $G = 2$ , and  $G = 5$  by replacing the feedback resistors (R33 and R34) and re-tested to show performance.

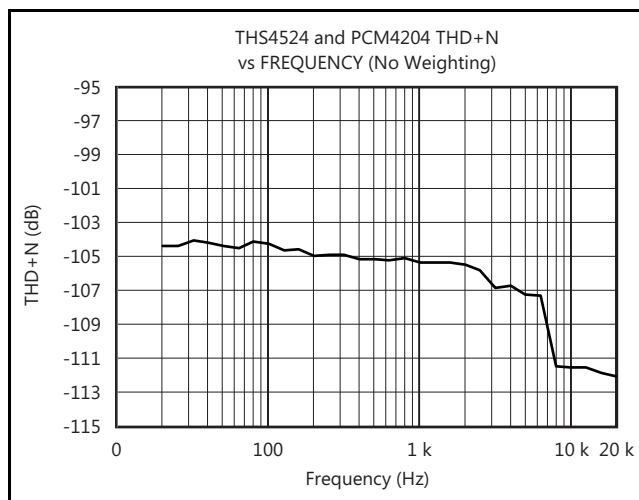


Figure 77. THS4524 and PCM4204: THD+N versus Frequency with No Weighting

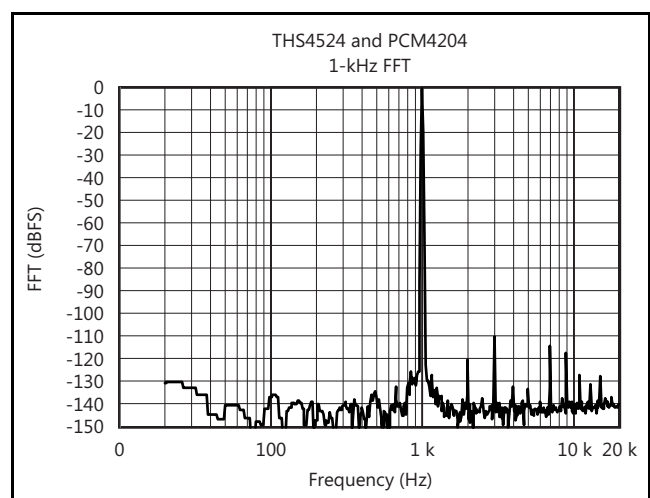


Figure 78. THS4524 and PCM4204 1-kHz FFT

THS4524-EP

ZHCS944A – JUNE 2012 – REVISED AUGUST 2013

www.ti.com.cn

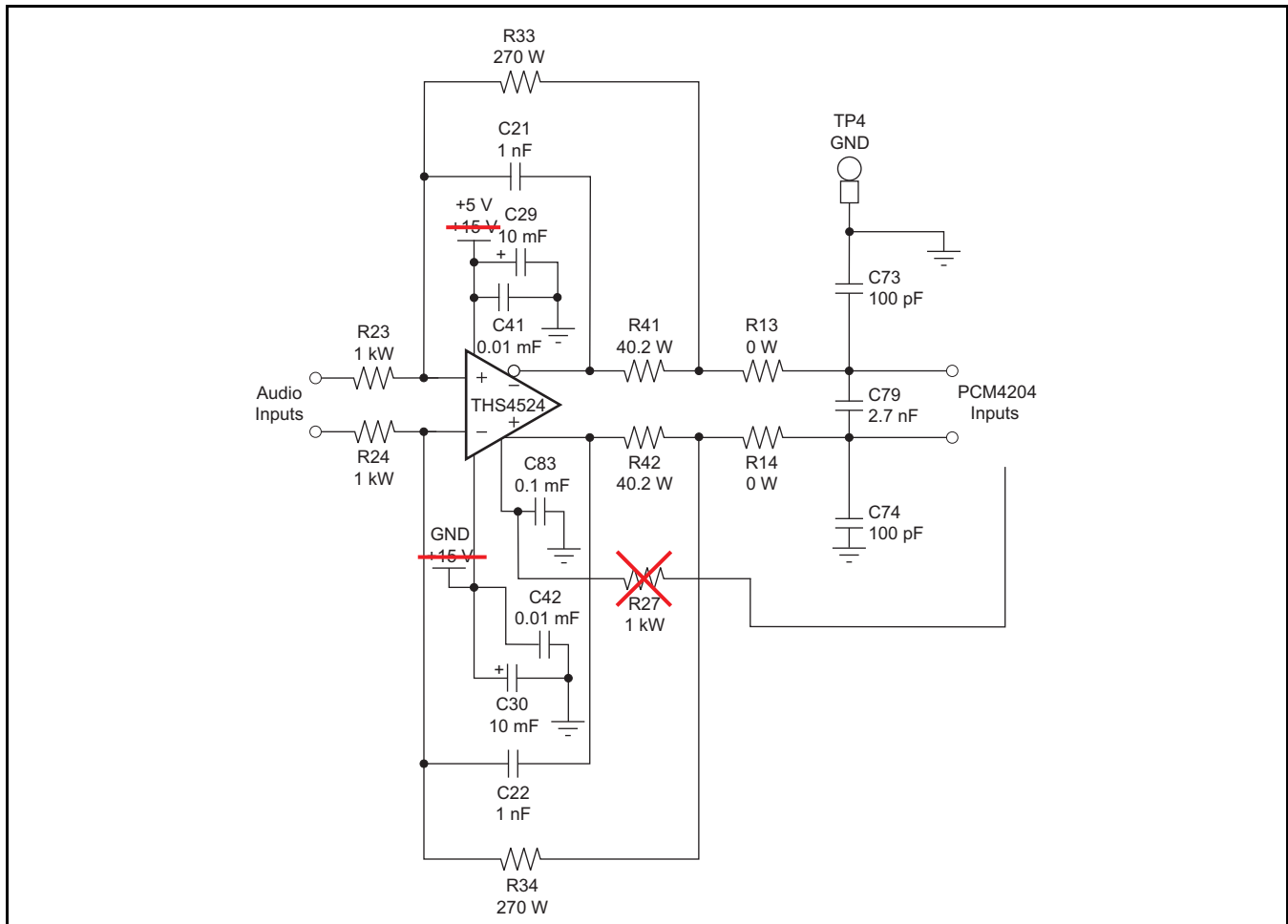


Figure 79. THS4524 and PCM4204 Test Circuit

Table 4. 1-kHz AC Analysis: Test Circuit versus PCM4204 Data Sheet Typical Specifications (f<sub>s</sub> = 48 kSPS)

Configuration	Tone	THD+N	Dynamic Range
THS4524 and PCM4204	1 kHz	-106 dBc	117 dB
<a href="#">PCM4204 Data sheet</a> (typ)	1 kHz	-105 dBc	118 dB

Figure 80 shows the THS4524 and PCM4204 THD+N versus frequency with no weighting at higher gains.

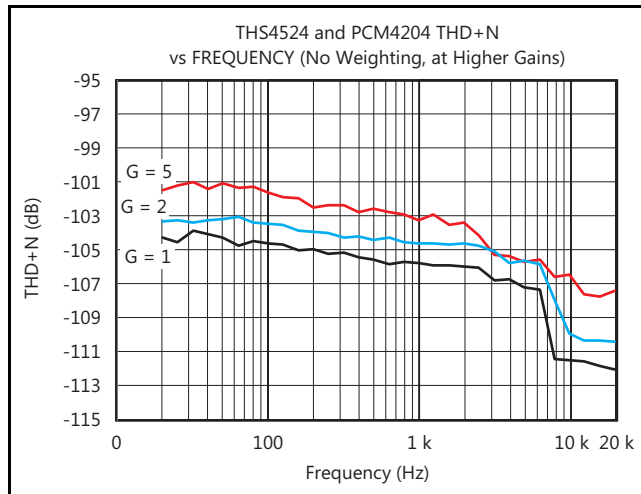


Figure 80. THS4524 and PCM4204: THD+N versus Frequency with No Weighting at Higher Gains

### Audio ADC Driver Performance: THS4524 and PCM3168 Combined Performance

The THS4524 is also tested as the drive amplifier for the PCM3168A ADC input. The PCM3168A is a high-performance, single-chip, 24-bit, 6-in/8-out, audio coder/decoder (codec) with single-ended and differential selectable analog inputs and differential outputs. The six-channel, 24-bit ADC employs a  $\Delta\Sigma$  modulator and supports 8-kHz to 96-kHz sampling rates and a 16-bit/24-bit width digital audio output word on the audio interface. The eight-channel, 24-bit digital-to-analog converter (DAC) employs a  $\Delta\Sigma$  modulator and supports 8-kHz to 192-kHz sampling rates and a 16-bit/24-bit width digital audio input word on the audio interface. Each audio interface supports I<sup>2</sup>S™, left/right-justified, and DSP formats with 16-bit/24-bit word width. In addition, the PCM3168A supports the time-division-multiplexed (TDM) format. The PCM3168A provides flexible serial port interface and many other advanced features. Refer to the PCM3168A product data sheet for more information.

The PCM3168A EVM is used to test the audio performance of the THS4524 as a drive amplifier. The standard PCM3168A EVM is provided with OPA2134 op amps that are used to convert single-ended inputs to differential to drive the ADC. For testing, the op amp output series resistors are removed from one of the channels and a THS4524, mounted on its standard EVM, is connected to the ADC inputs via short coaxial cables. The THS4524

EVM is configured for both differential inputs as shown in Figure 61 and for single-ended input as shown in Figure 62 with 1-k $\Omega$  resistors for R<sub>F</sub> and R<sub>G</sub>, and 24.9- $\Omega$  resistors in series with each output to isolate the outputs from the reactive load of the coaxial cables. To limit the noise from the external EVM and cables, a 2.7-nF capacitor is placed differentially across the PCM3168A inputs. The THS4524 is operated with a single-supply +5-V supply so the output common-mode of the THS4524 defaults to +2.5 V as required at the input of the PCM3168A. The PCM3168A EVM is configured and operated as described in the PCM3168A EVM User Guide. The ADC was tested with an external THS4524 EVM with both single-ended input and differential inputs. In both configurations, the results are the same. Figure 81 shows the THD+N versus frequency and Table 5 compares the result to the PCM3168 data sheet typical specification at 1 kHz. Both graphs show that it makes an excellent drive amplifier for this ADC. **Note:** a 2700 series Audio Analyzer from Audio Precision is used to generate the input signals to the THS4524 and to analyze the digital data from the PCM3168.

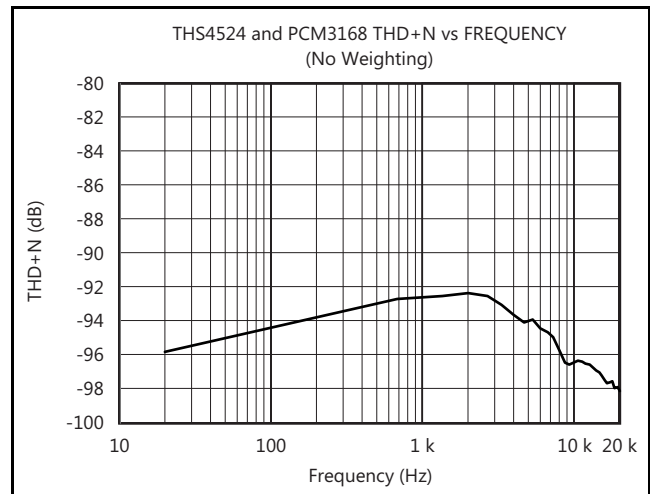


Figure 81. THS4524 and PCM3168: THD+N versus Frequency with No Weighting

Table 5. 1-kHz AC Analysis: Test Circuit vs PCM3168 Data Sheet Typical Specifications (f<sub>s</sub> = 48 kSPS)

Configuration	Tone	THD+N
THS4524 and PCM3168	1 kHz	-92.6 dBc
PCM3168 Data sheet (typ)	1 kHz	-93 dBc

# THS4524-EP

ZHCS944A – JUNE 2012 – REVISED AUGUST 2013

www.ti.com.cn

## ADC Driver Performance: THS4524 and ADS1278 Combined Performance

The THS4524 provides excellent performance when driving high-performance  $\Delta\Sigma$  and successive approximation register (SAR) ADCs in audio and industrial applications using a single 3-V to 5-V power supply. To show achievable performance, the THS4524 is tested as the drive amplifier for the ADS1278 24-bit ADC. The ADS1278 offers excellent ac and dc performance, with four selectable operating

modes from 10 kSPS to 128 kSPS to enable the user to fine-tune performance and power for specific application needs. The circuit shown in Figure 82 was used to test the performance. Data were taken using the High-Resolution mode (52 kSPS) of the ADS1278 with input frequencies at 1 kHz and 10 kHz and signal levels 1/2 dB below full-scale (–0.5 dBFS). FFT plots showing the spectral performance are given in Figure 83 and Figure 84; tabulated ac analysis results are shown in Table 6 and compared to the ADS1278 data sheet typical performance specifications.

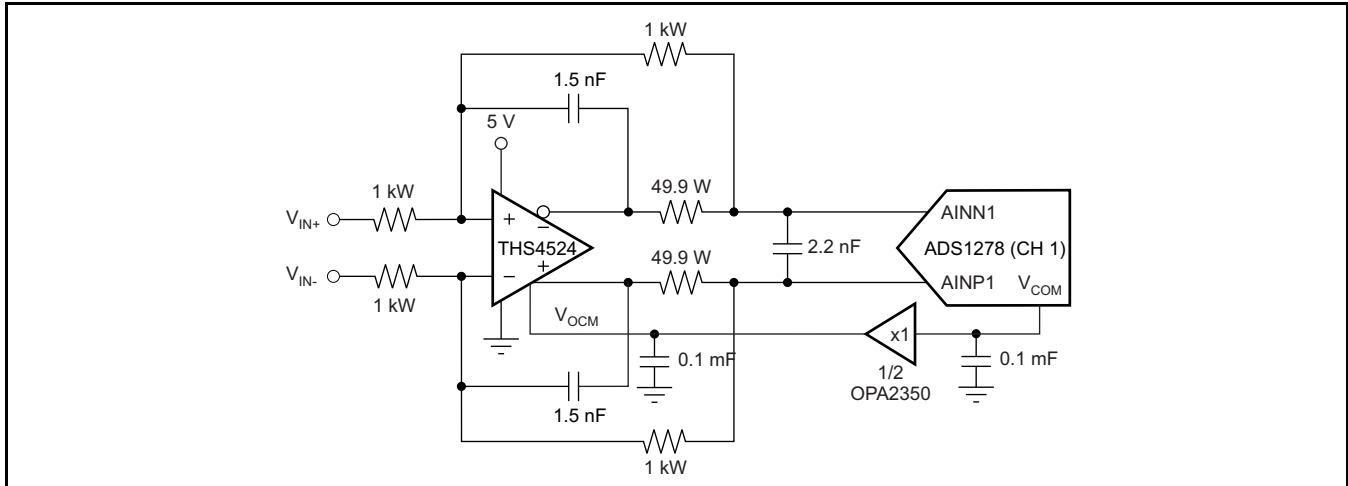


Figure 82. THS4524 and ADS1278 (Ch 1) Test Circuit

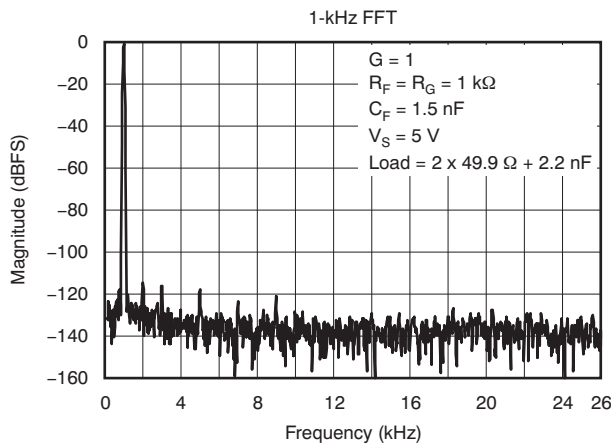


Figure 83. 1-kHz FFT

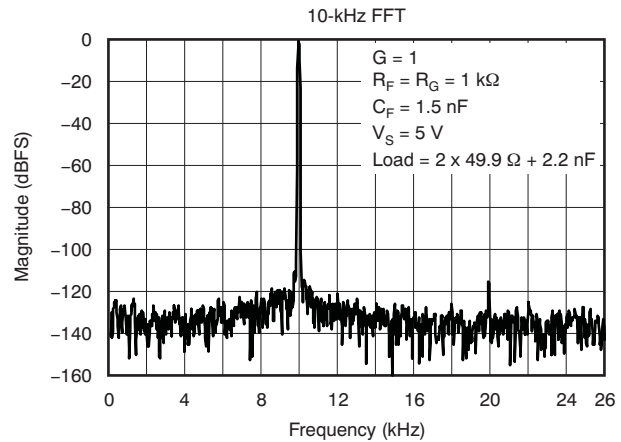


Figure 84. 10-kHz FFT

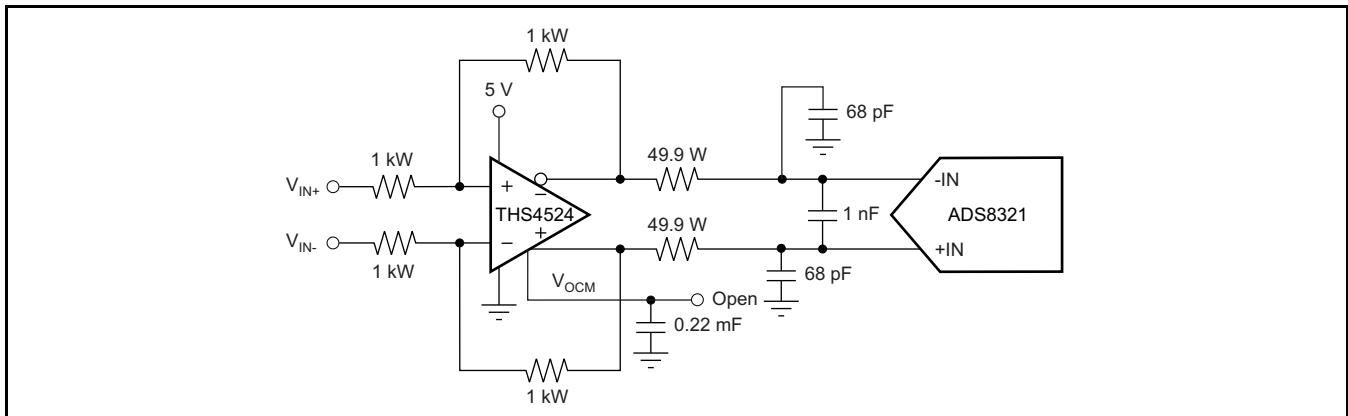
Table 6. AC Analysis

Configuration	Tone	Signal (dBFS)	SNR (dBc)	THD (dBc)	SINAD (dBc)	SFDR (dBc)
THS4524 and ADS1278	1 kHz	–0.5	109	–108	105	114
	10 kHz	–0.5	102	–110	101	110
ADS1278 Data sheet (typ)	1 kHz	–0.5	110	–108	—	109

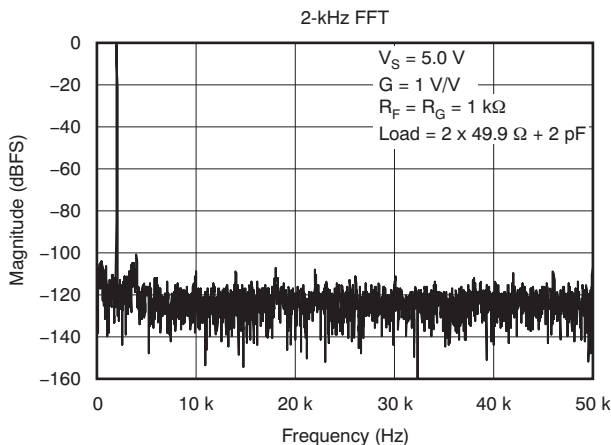
**ADC Driver Performance:  
THS4524 and ADS8321 Combined  
Performance**

To demonstrate achievable performance, the THS4524 is tested as the drive amplifier for the ADS8321 16-bit SAR ADC. The ADS8321 offers excellent ac and dc performance, with ultra-low power and small size. The circuit shown in Figure 85 was used to test the performance.

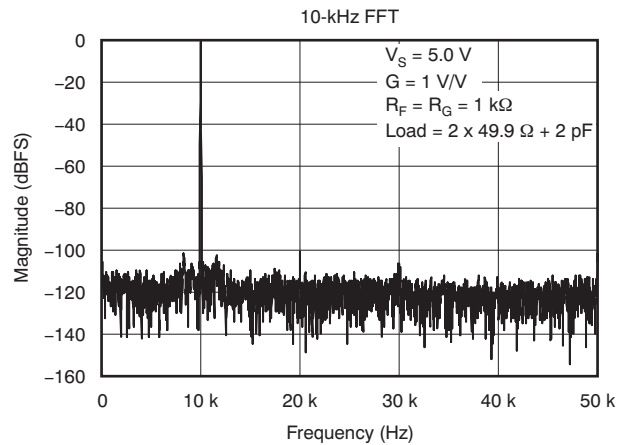
Data were taken using the ADS8321 at 100 kSPS with input frequencies of 2 kHz and 10 kHz and signal levels that were -0.5 dBFS. FFT plots that illustrate the spectral performance are given in Figure 86 and Figure 87. Tabulated ac analysis results are listed in Table 7 and compared to the ADS8321 data sheet typical performance.



**Figure 85. THS4524 and ADS8321 Test Circuit**



**Figure 86. 2-kHz FFT**



**Figure 87. 10-kHz FFT**

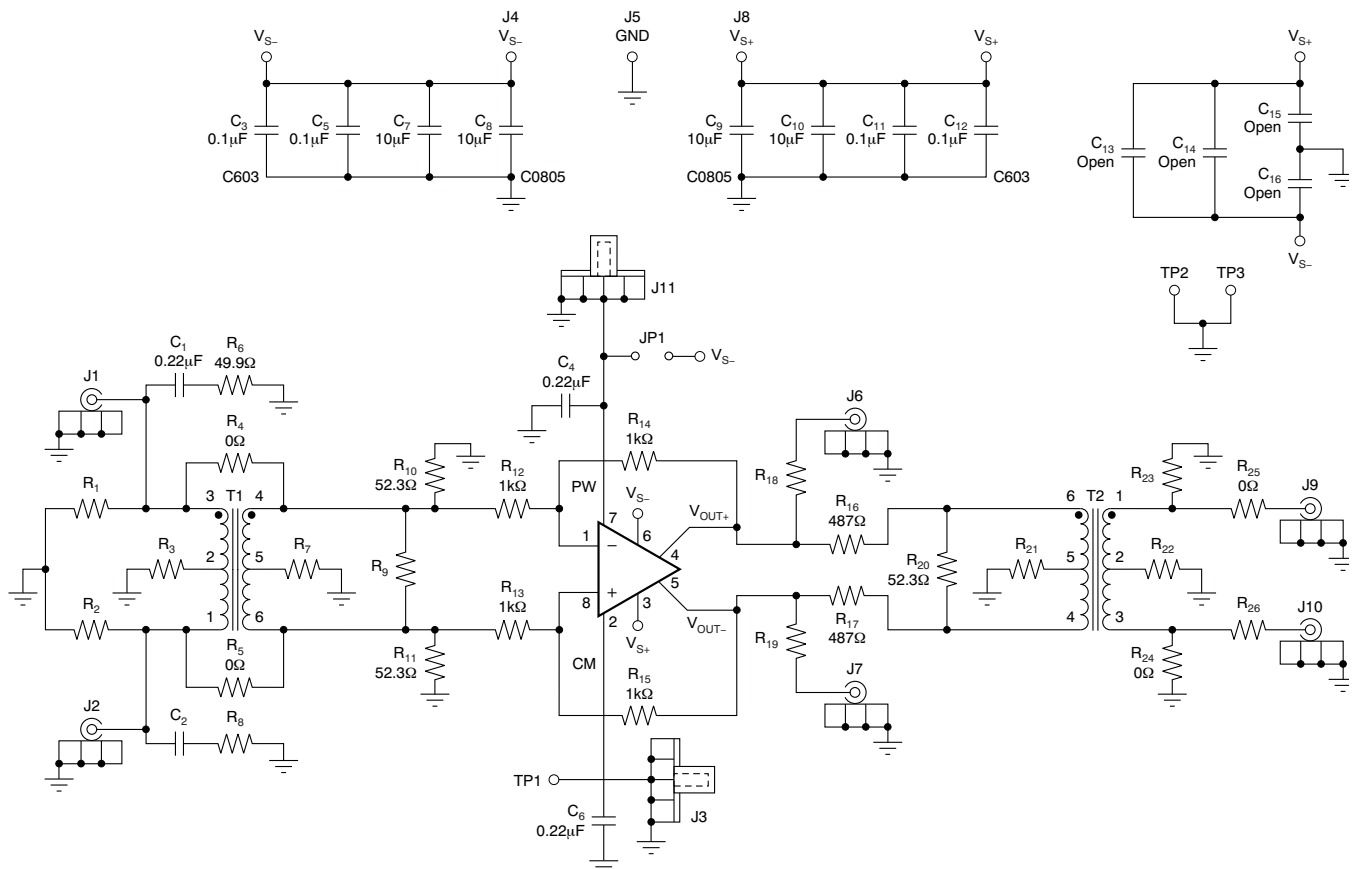
**Table 7. AC Analysis**

Configuration	Tone	Signal (dBFS)	SNR (dBc)	THD (dBc)	SINAD (dBc)	SFDR (dBc)
THS4524 and ADS8321	2 kHz	-0.5	86.7	-97.8	86.4	100.7
	10 kHz	-0.5	85.2	-98.1	85.2	102.2
ADS8321 Data sheet (typ)	10 kHz	-0.5	87	-86	84	86

## EVM AND LAYOUT RECOMMENDATIONS

Figure 88 shows the THS4524EVM schematic. PCB layers 1 through 4 are shown in Figure 89; Table 8 lists the bill of materials for the THS4524EVM as supplied from TI. It is recommended to follow the layout of the external components near to the amplifier, ground plane construction, and power routing as closely as possible. Follow these general guidelines:

1. Signal routing should be direct and as short as possible into and out of the op amp circuit.
2. The feedback path should be short and direct.
3. Ground or power planes should be removed from directly under the amplifier input and output pins.
4. An output resistor is recommended in each output lead, placed as near to the output pins as possible.
5. Two 0.1- $\mu\text{F}$  power-supply decoupling capacitors should be placed as near to the power-supply pins as possible.
6. Two 10- $\mu\text{F}$  power-supply decoupling capacitors should be placed within 1 inch of the device and can be shared among multiple analog devices.
7. A 0.22- $\mu\text{F}$  capacitor should be placed between the  $V_{\text{OCM}}$  input pin and ground near to the pin. This capacitor limits noise coupled into the pin.
8. The  $\overline{\text{PD}}$  pin uses TTL logic levels; a bypass capacitor is not necessary if actively driven, but can be used for robustness in noisy environments whether driven or not.
9. If input termination resistors  $R_{10}$  and  $R_{11}$  are used, a single point connection to ground on L2 is recommended.



**Figure 88. THS4524EVM: Schematic**

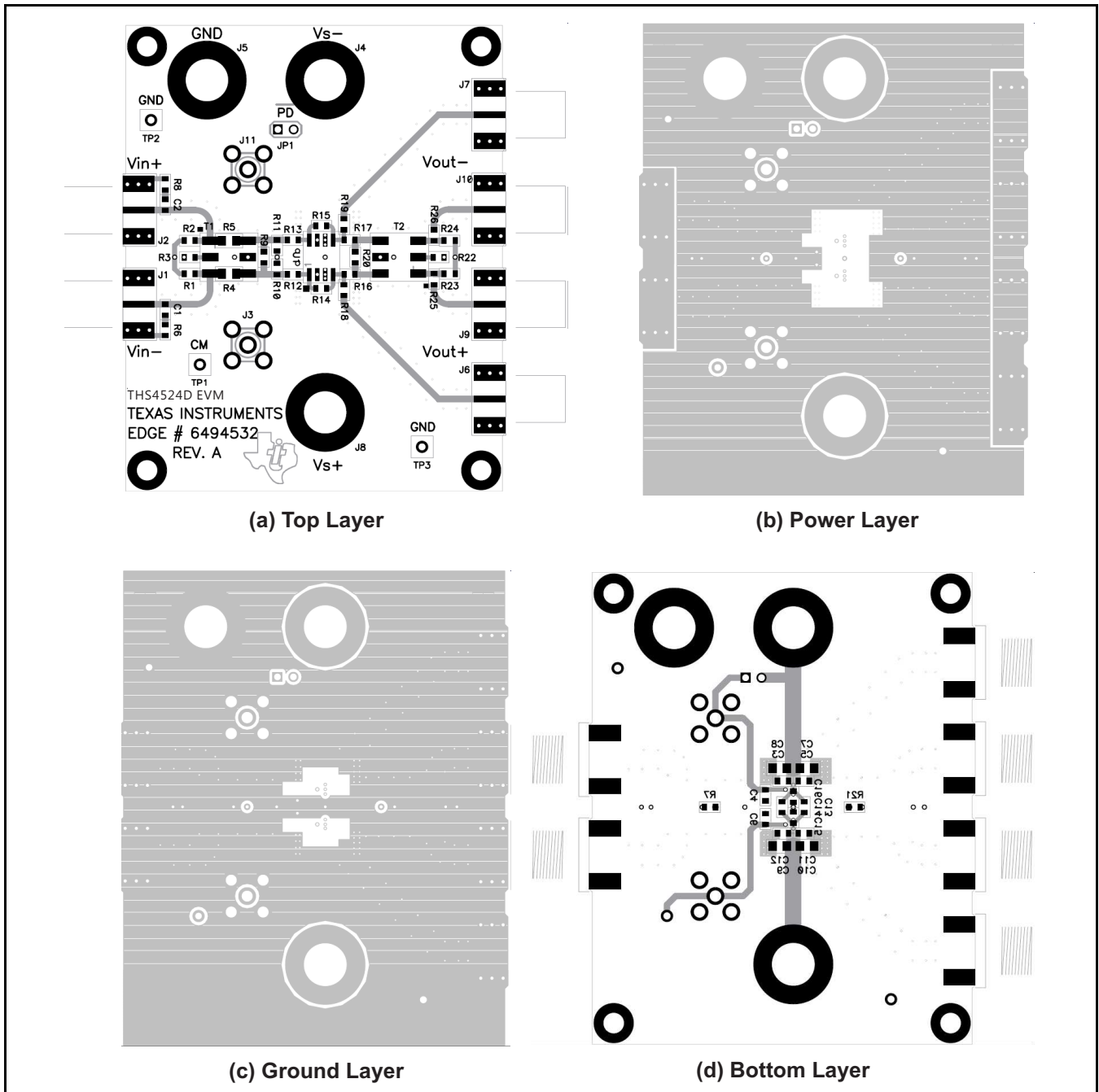


Figure 89. THS4524EVM: Layer 1 to Layer 4 Images

**Table 8. THS4524EVM Parts List**

ITEM	DESCRIPTION	SMD SIZE	REFERENCE DESIGNATOR	QTY	MANUFACTURER PART NUMBER
1	Capacitor, 10.0 $\mu$ F, ceramic, X5R, 6.3 V	0805	C7, C8, C9, C10	4	(AVX) 08056D106KAT2A
2	Capacitor, 0.1 $\mu$ F, ceramic, X7R, 16 V	0603	C3, C5, C11, C12	4	(AVX) 0603YC104KAT2A
3	Capacitor, 0.22 $\mu$ F, ceramic, X7R, 10 V	0603	C1, C4, C6	3	(AVX) 0603ZC224KAT2A
4	Open	0603	C2, C13, C14, C15, C16	5	
5	Open	0603	R1, R2, R3, R7, R8, R9, R18, R19, R21, R22, R23, R26	12	
6	Resistor, 0 $\Omega$	0603	R24, R25	2	(ROHM) MCR03EZPJ000
7	Resistor, 49.9 $\Omega$ , 1/10W, 1%	0603	R6	1	(ROHM) MCR03EZPFX49R9
8	Resistor, 52.3 $\Omega$ , 1/10W, 1%	0603	R10, R11, R20	3	(ROHM) MCR03EZPFX52R3
9	Resistor, 487 $\Omega$ , 1/10W, 1%	0603	R16, R17	2	(ROHM) MCR03EZPFX4870
10	Resistor, 1k $\Omega$ , 1/10W, 1%	0603	R12, R13, R14, R15	4	(ROHM) MCR03EZPFX1001
11	Resistor, 0 $\Omega$	0805	R4, R5	2	(ROHM) MCR10EZPJ000
12	Open		T1	1	
13	Transformer, RF		T2	1	(MINI-CIRCUITS) ADT1-1WT
14	Jack, Banana receptance, 0.25-in dia. hole		J4, J5, J8	3	(SPC) 813
15	Open		J1, J3, J6, J7, J10, J11	6	
16	Connector, edge, SMA PCB jack		J2, J9	2	(JOHNSON) 142-0701-801
17	Header, 0.1 in CTRS, 0.025-in sq. pins	2 POS.	JP1	1	(SULLINS) PBC36SAAN
18	Shunts		JP1	1	(SULLINS) SSC02SYAN
19	Test point, Red		TP1	1	(KEYSTONE) 5000
20	Test point, Black		TP2, TP3	2	(KEYSTONE) 5001
21	IC, THS4524		U1	1	(TI) THS4524D
22	Standoff, 4-40 hex, 0.625 in length			4	(KEYSTONE) 1808
23	Screw, Phillips, 4-40, .250 in			4	SHR-0440-016-SN
24	Board, printed circuit			1	(TI) EDGE# 6494532



## Evaluation Board/Kit Important Notice

Texas Instruments (TI) provides the enclosed product(s) under the following conditions:

This evaluation board/kit is intended for use for **ENGINEERING DEVELOPMENT, DEMONSTRATION, OR EVALUATION PURPOSES ONLY** and is not considered by TI to be a finished end-product fit for general consumer use. Persons handling the product(s) must have electronics training and observe good engineering practice standards. As such, the goods being provided are not intended to be complete in terms of required design-, marketing-, and/or manufacturing-related protective considerations, including product safety and environmental measures typically found in end products that incorporate such semiconductor components or circuit boards. This evaluation board/kit does not fall within the scope of the European Union directives regarding electromagnetic compatibility, restricted substances (RoHS), recycling (WEEE), FCC, CE or UL, and therefore may not meet the technical requirements of these directives or other related directives.

Should this evaluation board/kit not meet the specifications indicated in the User's Guide, the board/kit may be returned within 30 days from the date of delivery for a full refund. **THE FOREGOING WARRANTY IS THE EXCLUSIVE WARRANTY MADE BY SELLER TO BUYER AND IS IN LIEU OF ALL OTHER WARRANTIES, EXPRESSED, IMPLIED, OR STATUTORY, INCLUDING ANY WARRANTY OF MERCHANTABILITY OR FITNESS FOR ANY PARTICULAR PURPOSE.**

The user assumes all responsibility and liability for proper and safe handling of the goods. Further, the user indemnifies TI from all claims arising from the handling or use of the goods. Due to the open construction of the product, it is the user's responsibility to take any and all appropriate precautions with regard to electrostatic discharge.

**EXCEPT TO THE EXTENT OF THE INDEMNITY SET FORTH ABOVE, NEITHER PARTY SHALL BE LIABLE TO THE OTHER FOR ANY INDIRECT, SPECIAL, INCIDENTAL, OR CONSEQUENTIAL DAMAGES.**

TI currently deals with a variety of customers for products, and therefore our arrangement with the user **is not exclusive**.

TI assumes **no liability for applications assistance, customer product design, software performance, or infringement of patents or services described herein.**

Please read the User's Guide and, specifically, the Warnings and Restrictions notice in the User's Guide prior to handling the product. This notice contains important safety information about temperatures and voltages. For additional information on TI's environmental and/or safety programs, please contact the TI application engineer or visit [www.ti.com/esh](http://www.ti.com/esh).

No license is granted under any patent right or other intellectual property right of TI covering or relating to any machine, process, or combination in which such TI products or services might be or are used.

## FCC Warning

This evaluation board/kit is intended for use for **ENGINEERING DEVELOPMENT, DEMONSTRATION, OR EVALUATION PURPOSES ONLY** and is not considered by TI to be a finished end-product fit for general consumer use. It generates, uses, and can radiate radio frequency energy and has not been tested for compliance with the limits of computing devices pursuant to part 15 of FCC rules, which are designed to provide reasonable protection against radio frequency interference. Operation of this equipment in other environments may cause interference with radio communications, in which case the user at his own expense will be required to take whatever measures may be required to correct this interference.

## EVM Warnings and Restrictions

It is important to operate this EVM within the input voltage range of 3 V to 5.5 V and the output voltage range of 3 V to 5.5 V.

Exceeding the specified input range may cause unexpected operation and/or irreversible damage to the EVM. If there are questions concerning the input range, please contact a TI field representative prior to connecting the input power.

Applying loads outside of the specified output range may result in unintended operation and/or possible permanent damage to the EVM. Please consult the EVM User's Guide prior to connecting any load to the EVM output. If there is uncertainty as to the load specification, please contact a TI field representative.

During normal operation, some circuit components may have case temperatures greater than 125°C. The EVM is designed to operate properly with certain components above 125°C as long as the input and output ranges are maintained. These components include but are not limited to linear regulators, switching transistors, pass transistors, and current sense resistors. These types of devices can be identified using the EVM schematic located in the EVM User's Guide. When placing measurement probes near these devices during operation, please be aware that these devices may be very warm to the touch.

邮寄地址: 上海市浦东新区世纪大道1568号, 中建大厦32楼 邮政编码: 200122  
Copyright © 2013, 德州仪器半导体技术(上海)有限公司

**PACKAGING INFORMATION**

Orderable Device	Status (1)	Package Type	Package Drawing	Pins	Package Qty	Eco Plan (2)	Lead/Ball Finish	MSL Peak Temp (3)	Op Temp (°C)	Device Marking (4/5)	Samples
THS4524MDBTEP	PREVIEW	TSSOP	DBT	38	50	Green (RoHS & no Sb/Br)	CU NIPDAU	Level-2-260C-1 YEAR	-55 to 125	THS4524EP	
THS4524MDBTREP	ACTIVE	TSSOP	DBT	38	2000	Green (RoHS & no Sb/Br)	CU NIPDAU	Level-2-260C-1 YEAR	-55 to 125	THS4524EP	<a href="#">Samples</a>
V62/12612-01XE	ACTIVE	TSSOP	DBT	38	2000	Green (RoHS & no Sb/Br)	CU NIPDAU	Level-2-260C-1 YEAR	-55 to 125	THS4524EP	<a href="#">Samples</a>

(1) The marketing status values are defined as follows:

**ACTIVE:** Product device recommended for new designs.

**LIFEBUY:** TI has announced that the device will be discontinued, and a lifetime-buy period is in effect.

**NRND:** Not recommended for new designs. Device is in production to support existing customers, but TI does not recommend using this part in a new design.

**PREVIEW:** Device has been announced but is not in production. Samples may or may not be available.

**OBSELETE:** TI has discontinued the production of the device.

(2) Eco Plan - The planned eco-friendly classification: Pb-Free (RoHS), Pb-Free (RoHS Exempt), or Green (RoHS & no Sb/Br) - please check <http://www.ti.com/productcontent> for the latest availability information and additional product content details.

**TBD:** The Pb-Free/Green conversion plan has not been defined.

**Pb-Free (RoHS):** TI's terms "Lead-Free" or "Pb-Free" mean semiconductor products that are compatible with the current RoHS requirements for all 6 substances, including the requirement that lead not exceed 0.1% by weight in homogeneous materials. Where designed to be soldered at high temperatures, TI Pb-Free products are suitable for use in specified lead-free processes.

**Pb-Free (RoHS Exempt):** This component has a RoHS exemption for either 1) lead-based flip-chip solder bumps used between the die and package, or 2) lead-based die adhesive used between the die and leadframe. The component is otherwise considered Pb-Free (RoHS compatible) as defined above.

**Green (RoHS & no Sb/Br):** TI defines "Green" to mean Pb-Free (RoHS compatible), and free of Bromine (Br) and Antimony (Sb) based flame retardants (Br or Sb do not exceed 0.1% by weight in homogeneous material)

(3) MSL, Peak Temp. -- The Moisture Sensitivity Level rating according to the JEDEC industry standard classifications, and peak solder temperature.

(4) There may be additional marking, which relates to the logo, the lot trace code information, or the environmental category on the device.

(5) Multiple Device Markings will be inside parentheses. Only one Device Marking contained in parentheses and separated by a "~" will appear on a device. If a line is indented then it is a continuation of the previous line and the two combined represent the entire Device Marking for that device.

**Important Information and Disclaimer:** The information provided on this page represents TI's knowledge and belief as of the date that it is provided. TI bases its knowledge and belief on information provided by third parties, and makes no representation or warranty as to the accuracy of such information. Efforts are underway to better integrate information from third parties. TI has taken and continues to take reasonable steps to provide representative and accurate information but may not have conducted destructive testing or chemical analysis on incoming materials and chemicals. TI and TI suppliers consider certain information to be proprietary, and thus CAS numbers and other limited information may not be available for release.

In no event shall TI's liability arising out of such information exceed the total purchase price of the TI part(s) at issue in this document sold by TI to Customer on an annual basis.

**OTHER QUALIFIED VERSIONS OF THS4524-EP :**

- Catalog: [THS4524](#)

NOTE: Qualified Version Definitions:

- Catalog - TI's standard catalog product

## TAPE AND REEL INFORMATION



### QUADRANT ASSIGNMENTS FOR PIN 1 ORIENTATION IN TAPE



\*All dimensions are nominal

Device	Package Type	Package Drawing	Pins	SPQ	Reel Diameter (mm)	Reel Width W1 (mm)	A0 (mm)	B0 (mm)	K0 (mm)	P1 (mm)	W (mm)	Pin1 Quadrant
THS4524MDBTREP	TSSOP	DBT	38	2000	330.0	16.4	6.9	10.2	1.8	12.0	16.0	Q1

**TAPE AND REEL BOX DIMENSIONS**



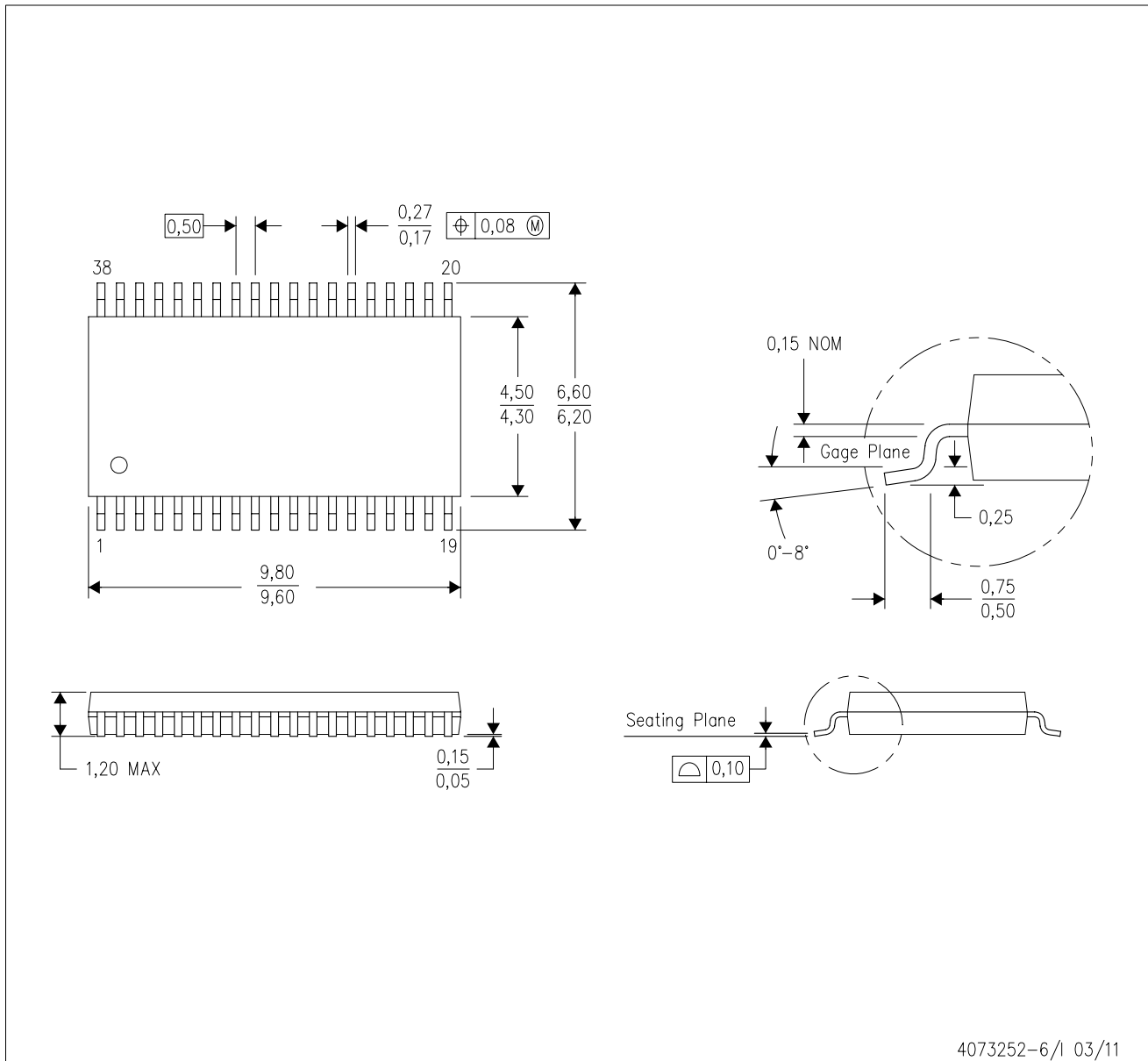
\*All dimensions are nominal

Device	Package Type	Package Drawing	Pins	SPQ	Length (mm)	Width (mm)	Height (mm)
THS4524MDBTREP	TSSOP	DBT	38	2000	367.0	367.0	38.0

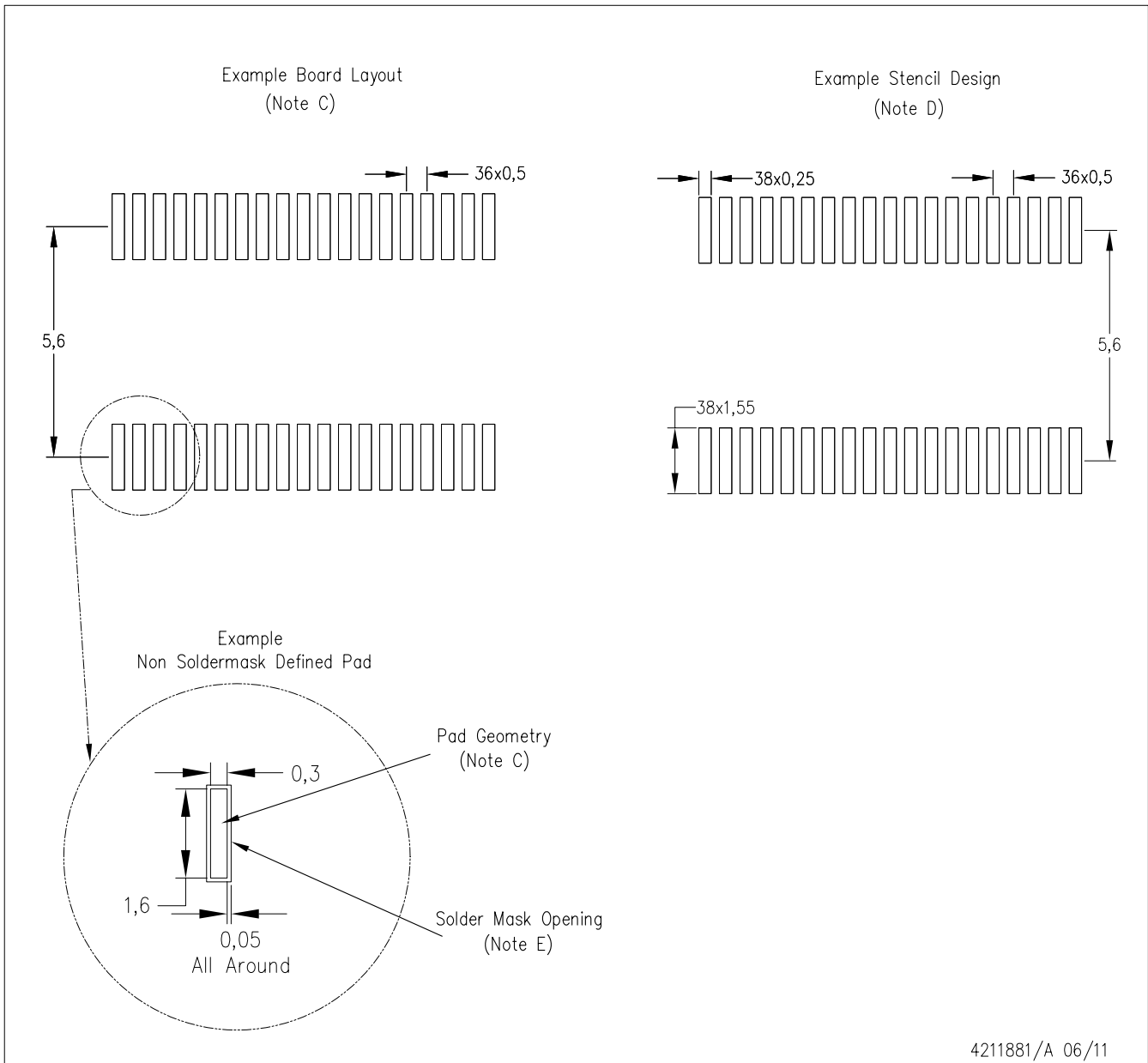
# MECHANICAL DATA

DBT (R-PDSO-G38)

PLASTIC SMALL OUTLINE



- NOTES:
- All linear dimensions are in millimeters. Dimensioning and tolerancing per ASME Y14.5M-1994.
  - This drawing is subject to change without notice.
  - Body dimensions do not include mold flash or protrusion.
  - Falls within JEDEC MO-153.



- NOTES:
- A. All linear dimensions are in millimeters.
  - B. This drawing is subject to change without notice.
  - C. Publication IPC-7351 is recommended for alternate designs.
  - D. Laser cutting apertures with trapezoidal walls and also rounding corners will offer better paste release. Customers should contact their board assembly site for stencil design recommendations. Refer to IPC-7525.
  - E. Customers should contact their board fabrication site for solder mask tolerances between and around signal pads.

## 重要声明

德州仪器(TI) 及其下属子公司有权根据 JESD46 最新标准, 对所提供的产品和服务进行更正、修改、增强、改进或其它更改, 并有权根据 JESD48 最新标准中止提供任何产品和服务。客户在下订单前应获取最新的相关信息, 并验证这些信息是否完整且是最新的。所有产品的销售都遵循在订单确认时所提供的TI 销售条款与条件。

TI 保证其所销售的组件的性能符合产品销售时 TI 半导体产品销售条件与条款的适用规范。仅在 TI 保证的范围内, 且 TI 认为有必要时才会使用测试或其它质量控制技术。除非适用法律做出了硬性规定, 否则没有必要对每种组件的所有参数进行测试。

TI 对应用帮助或客户产品设计不承担任何义务。客户应对其使用 TI 组件的产品和应用自行负责。为尽量减小与客户产品和应用相关的风险, 客户应提供充分的设计与操作安全措施。

TI 不对任何 TI 专利权、版权、屏蔽作品权或其它与使用了 TI 组件或服务的组合设备、机器或流程相关的 TI 知识产权中授予的直接或隐含权作出任何保证或解释。TI 所发布的与第三方产品或服务有关的信息, 不能构成从 TI 获得使用这些产品或服务的许可、授权、或认可。使用此类信息可能需要获得第三方的专利权或其它知识产权方面的许可, 或是 TI 的专利权或其它知识产权方面的许可。

对于 TI 的产品手册或数据表中 TI 信息的重要部分, 仅在没有对内容进行任何篡改且带有相关授权、条件、限制和声明的情况下才允许进行复制。TI 对此类篡改过的文件不承担任何责任或义务。复制第三方的信息可能需要服从额外的限制条件。

在转售 TI 组件或服务时, 如果对该组件或服务参数的陈述与 TI 标明的参数相比存在差异或虚假成分, 则会失去相关 TI 组件或服务的所有明示或暗示授权, 且这是不正当的、欺诈性商业行为。TI 对任何此类虚假陈述均不承担任何责任或义务。

客户认可并同意, 尽管任何应用相关信息或支持仍可能由 TI 提供, 但他们将独力负责满足与其产品及其应用中使用的 TI 产品相关的所有法律、法规和安全相关要求。客户声明并同意, 他们具备制定与实施安全措施所需的全部专业技术和知识, 可预见故障的危险后果、监测故障及其后果、降低有可能造成人身伤害的故障的发生机率并采取适当的补救措施。客户将全额赔偿因在此类安全关键应用中使用任何 TI 组件而对 TI 及其代理造成的任何损失。

在某些场合中, 为了推进安全相关应用有可能对 TI 组件进行特别的促销。TI 的目标是利用此类组件帮助客户设计和创立其特有的可满足适用的功能安全性标准和要求的终端产品解决方案。尽管如此, 此类组件仍然服从这些条款。

TI 组件未获得用于 FDA Class III (或类似的生命攸关医疗设备) 的授权许可, 除非各方授权官员已经达成了专门管控此类使用的特别协议。

只有那些 TI 特别注明属于军用等级或“增强型塑料”的 TI 组件才是设计或专门用于军事/航空应用或环境的。购买者认可并同意, 对并非指定面向军事或航空航天用途的 TI 组件进行军事或航空航天方面的应用, 其风险由客户单独承担, 并且由客户独力负责满足与此类使用相关的所有法律和法规要求。

TI 已明确指定符合 ISO/TS16949 要求的产品, 这些产品主要用于汽车。在任何情况下, 因使用非指定产品而无法达到 ISO/TS16949 要求, TI 不承担任何责任。

	产品		应用
数字音频	<a href="http://www.ti.com.cn/audio">www.ti.com.cn/audio</a>	通信与电信	<a href="http://www.ti.com.cn/telecom">www.ti.com.cn/telecom</a>
放大器和线性器件	<a href="http://www.ti.com.cn/amplifiers">www.ti.com.cn/amplifiers</a>	计算机及周边	<a href="http://www.ti.com.cn/computer">www.ti.com.cn/computer</a>
数据转换器	<a href="http://www.ti.com.cn/dataconverters">www.ti.com.cn/dataconverters</a>	消费电子	<a href="http://www.ti.com.cn/consumer-apps">www.ti.com.cn/consumer-apps</a>
DLP® 产品	<a href="http://www.dlp.com">www.dlp.com</a>	能源	<a href="http://www.ti.com.cn/energy">www.ti.com.cn/energy</a>
DSP - 数字信号处理器	<a href="http://www.ti.com.cn/dsp">www.ti.com.cn/dsp</a>	工业应用	<a href="http://www.ti.com.cn/industrial">www.ti.com.cn/industrial</a>
时钟和计时器	<a href="http://www.ti.com.cn/clockandtimers">www.ti.com.cn/clockandtimers</a>	医疗电子	<a href="http://www.ti.com.cn/medical">www.ti.com.cn/medical</a>
接口	<a href="http://www.ti.com.cn/interface">www.ti.com.cn/interface</a>	安防应用	<a href="http://www.ti.com.cn/security">www.ti.com.cn/security</a>
逻辑	<a href="http://www.ti.com.cn/logic">www.ti.com.cn/logic</a>	汽车电子	<a href="http://www.ti.com.cn/automotive">www.ti.com.cn/automotive</a>
电源管理	<a href="http://www.ti.com.cn/power">www.ti.com.cn/power</a>	视频和影像	<a href="http://www.ti.com.cn/video">www.ti.com.cn/video</a>
微控制器 (MCU)	<a href="http://www.ti.com.cn/microcontrollers">www.ti.com.cn/microcontrollers</a>		
RFID 系统	<a href="http://www.ti.com.cn/rfidsys">www.ti.com.cn/rfidsys</a>		
OMAP应用处理器	<a href="http://www.ti.com.cn/omap">www.ti.com.cn/omap</a>		
无线连通性	<a href="http://www.ti.com.cn/wirelessconnectivity">www.ti.com.cn/wirelessconnectivity</a>	德州仪器在线技术支持社区	<a href="http://www.deyisupport.com">www.deyisupport.com</a>

邮寄地址: 上海市浦东新区世纪大道 1568 号, 中建大厦 32 楼 邮政编码: 200122  
Copyright © 2013 德州仪器 半导体技术 (上海) 有限公司