

INA333 低功耗 (50 μ A)、零漂移、轨到轨输出仪表放大器

1 特性

- 低偏移电压: 25 μ V (最大值), $G \geq 100$
- 低漂移: 0.1 μ V/ $^{\circ}$ C, $G \geq 100$
- 低噪声: 50nV/ $\sqrt{\text{Hz}}$, $G \geq 100$
- 高共模抑制比 (CMRR): 100dB (最小值), $G \geq 10$
- 低输入偏置电流: 200pA (最大值)
- 电源范围: 1.8V 至 5.5V
- 输入电压: (V-) + 0.1V 至 (V+) - 0.1V
- 输出电压: (V-) + 0.05V 至 (V+) - 0.05V
- 低静态电流: 50 μ A
- 工作温度范围: -40 $^{\circ}$ C 至 +125 $^{\circ}$ C
- 已过滤射频干扰 (RFI) 的输入
- 8 引脚 VSSOP 和 8 引脚 WSON 封装

2 应用范围

- 桥式放大器
- 心电图 (ECG) 放大器
- 压力传感器
- 医疗仪表
- 便携式仪表
- 衡器
- 热电偶放大器
- 电阻式温度检测器 (RTD) 传感器放大器
- 数据采集

3 说明

INA333 器件是一款低功耗的精密仪表放大器, 具有出色的精度。该器件采用通用的三运算放大器设计, 并且拥有小巧尺寸和低功耗特性, 非常适合各类便携式应用。

可通过单个外部电阻在 1 到 1000 范围内设置增益。

INA333 设计为采用符合行业标准的增益公式: $G = 1 + (100\text{k}\Omega/R_G)$ 。

INA333 器件拥有超低的偏移电压 (25 μ V, $G \geq 100$), 出色的偏移电压漂移 (0.1 μ V/ $^{\circ}$ C, $G \geq 100$), 以及较高的共模抑制比 (100dB, $G \geq 10$)。该器件可由低至 1.8V (± 0.9 V) 的电源供电运行, 静态电流仅为 50 μ A, 因此非常适合电池供电类系统。INA333 器件采用自动校准技术在扩展工业温度范围内保证了出色的精度, 同时还提供了向下扩展至直流的超低噪声密度 (50nV/ $\sqrt{\text{Hz}}$)。

INA333 器件采用 8 引脚 VSSOP 和 WSON 表面贴装封装, 额定温度范围 $T_A = -40^{\circ}\text{C}$ 至 +125 $^{\circ}\text{C}$ 。

器件信息⁽¹⁾

器件型号	封装	封装尺寸 (标称值)
INA333	VSSOP (8)	3.00mm x 3.00mm
	WSON (8)	3.00mm x 3.00mm

(1) 要了解所有可用封装, 请见数据表末尾的可订购产品附录。

简化电路原理图

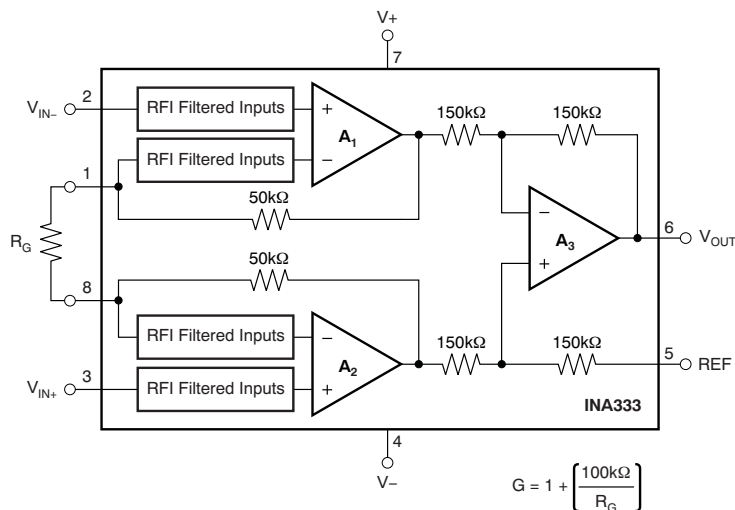

目录

1	特性	1	7.4	Device Functional Modes.....	13
2	应用范围.....	1	8	Application and Implementation	14
3	说明	1	8.1	Application Information.....	14
4	修订历史记录	2	8.2	Typical Application	14
5	Pin Configuration and Functions	3	9	Power Supply Recommendations	19
6	Specifications.....	4	10	Layout.....	20
6.1	Absolute Maximum Ratings	4	10.1	Layout Guidelines	20
6.2	ESD Ratings.....	4	10.2	Layout Example	20
6.3	Recommended Operating Conditions.....	4	11	器件和文档支持	21
6.4	Thermal Information	4	11.1	器件支持	21
6.5	Electrical Characteristics.....	5	11.2	文档支持	22
6.6	Typical Characteristics.....	7	11.3	商标	22
7	Detailed Description	13	11.4	静电放电警告.....	22
7.1	Overview	13	11.5	Glossary	23
7.2	Functional Block Diagram	13	12	机械、封装和可订购信息.....	23
7.3	Feature Description.....	13			

4 修订历史记录

注：之前版本的页码可能与当前版本有所不同。

Changes from Revision B (October 2008) to Revision C

Page

- | | |
|---|----------|
| • 已添加 ESD 额定值表，特性描述部分，器件功能模式，应用和实施部分，电源相关建议部分，布局部分，器件和文档支持部分以及机械、封装和可订购信息部分 | 1 |
|---|----------|

5 Pin Configuration and Functions

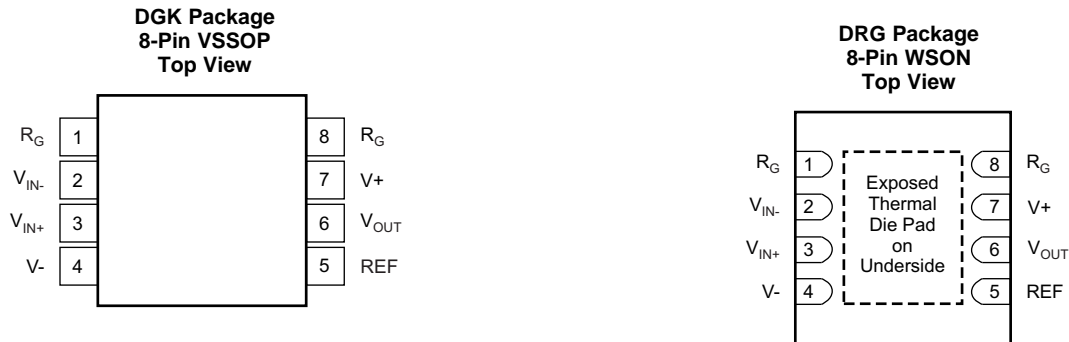

Pin Functions

PIN		I/O	DESCRIPTION
NAME	NO.		
REF	5	I	Reference input. This pin must be driven by low impedance or connected to ground.
RG	1, 8	—	Gain setting pins. For gains greater than 1, place a gain resistor between pins 1 and 8.
V ⁺	7	—	Positive supply
V ⁻	4	—	Negative supply
V _{IN+}	3	I	Positive input
V _{IN-}	2	I	Negative input
V _{OUT}	6	O	Output

6 Specifications

6.1 Absolute Maximum Ratings

 over operating free-air temperature range (unless otherwise noted) ⁽¹⁾

	MIN	MAX	UNIT
Supply voltage	7		V
Analog input voltage ⁽²⁾	(V ₋) - 0.3	(V ₊) + 0.3	V
Output short-circuit ⁽³⁾	Continuous		
Operating temperature, T _A	-40	150	°C
Junction temperature, T _J		150	°C
Storage temperature, T _{stg}	-65	150	°C

- (1) Stresses beyond those listed under *Absolute Maximum Ratings* may cause permanent damage to the device. These are stress ratings only, which do not imply functional operation of the device at these or any other conditions beyond those indicated under *Recommended Operating Conditions*. Exposure to absolute-maximum-rated conditions for extended periods may affect device reliability.
- (2) Input pins are diode-clamped to the power-supply rails. Input signals that can swing more than 0.3 V beyond the supply rails should be current limited to 10 mA or less.
- (3) Short-circuit to ground.

6.2 ESD Ratings

		VALUE	UNIT
V _(ESD) Electrostatic discharge	Human-body model (HBM), per ANSI/ESDA/JEDEC JS-001 ⁽¹⁾	±4000	V
	Charged-device model (CDM), per JEDEC specification JESD22-C101 ⁽²⁾	±1000	
	Machine model (MM)	±200	

- (1) JEDEC document JEP155 states that 500-V HBM allows safe manufacturing with a standard ESD control process.
- (2) JEDEC document JEP157 states that 250-V CDM allows safe manufacturing with a standard ESD control process.

6.3 Recommended Operating Conditions

over operating free-air temperature range (unless otherwise noted)

		MIN	MAX	UNIT
V _S	Supply voltage	1.8	5.5	V
	Specified temperature	-40	125	°C

6.4 Thermal Information

THERMAL METRIC ⁽¹⁾		INA333		UNIT
		DGK (VSSOP)	DRG (WSON)	
		8 PINS	8 PINS	
R _{θJA}	Junction-to-ambient thermal resistance	169.5	60	°C/W
R _{θJC(top)}	Junction-to-case (top) thermal resistance	62.7	60	°C/W
R _{θJB}	Junction-to-board thermal resistance	90.3	50	°C/W
ψ _{JT}	Junction-to-top characterization parameter	7.6	—	°C/W
ψ _{JB}	Junction-to-board characterization parameter	88.7	—	°C/W
R _{θJC(bot)}	Junction-to-case (bottom) thermal resistance	—	6	°C/W

- (1) For more information about traditional and new thermal metrics, see the *Semiconductor and IC Package Thermal Metrics* application report, [SPRA953](http://www.ti.com/lit/zip/Spra953).

6.5 Electrical Characteristics

for $V_S = 1.8\text{ V to }5.5\text{ V}$ at $T_A = 25^\circ\text{C}$, $R_L = 10\text{ k}\Omega$, $V_{REF} = V_S / 2$, and $G = 1$ (unless otherwise noted)

PARAMETER		TEST CONDITIONS	MIN	TYP	MAX	UNIT
INPUT⁽¹⁾						
V_{OSI}	Offset voltage, RTI ⁽²⁾			$\pm 10 \pm 25/G$	$\pm 25 \pm 75/G$	μV
	vs temperature	$T_A = -40^\circ\text{C to }+125^\circ\text{C}$			$\pm 0.1 \pm 0.5 / G$	$\mu\text{V}/^\circ\text{C}$
PSR	vs power supply	$1.8\text{ V} \leq V_S \leq 5.5\text{ V}$		$\pm 1 \pm 5/G$	$\pm 5 \pm 15/G$	$\mu\text{V}/\text{V}$
	Long-term stability			See ⁽³⁾		
	Turnon time to specified V_{OSI}	$T_A = -40^\circ\text{C to }+125^\circ\text{C}$		See Typical Characteristics		
	Impedance					
Z_{IN}	Differential			100 3		$\text{G}\Omega \parallel \text{pF}$
Z_{IN}	Common-mode			100 3		$\text{G}\Omega \parallel \text{pF}$
V_{CM}	Common-mode voltage range	$V_O = 0\text{ V}$	$(V-) + 0.1$		$(V+) - 0.1$	V
CMR	Common-mode rejection	DC to 60 Hz				
	$G = 1$	$V_{CM} = (V-) + 0.1\text{ V}$ to $(V+) - 0.1\text{ V}$	80	90		dB
	$G = 10$	$V_{CM} = (V-) + 0.1\text{ V}$ to $(V+) - 0.1\text{ V}$	100	110		dB
	$G = 100$	$V_{CM} = (V-) + 0.1\text{ V}$ to $(V+) - 0.1\text{ V}$	100	115		dB
	$G = 1000$	$V_{CM} = (V-) + 0.1\text{ V}$ to $(V+) - 0.1\text{ V}$	100	115		dB
INPUT BIAS CURRENT						
I_B	Input bias current			± 70	± 200	pA
	vs temperature	$T_A = -40^\circ\text{C to }+125^\circ\text{C}$		See Figure 26		$\text{pA}/^\circ\text{C}$
I_{OS}	Input offset current			± 50	± 200	pA
	vs temperature	$T_A = -40^\circ\text{C to }+125^\circ\text{C}$		See Figure 28		$\text{pA}/^\circ\text{C}$
INPUT VOLTAGE NOISE						
e_{NI}	Input voltage noise	$G = 100, R_S = 0\ \Omega, f = 10\text{ Hz}$		50		$\text{nV}/\sqrt{\text{Hz}}$
		$G = 100, R_S = 0\ \Omega, f = 100\text{ Hz}$		50		$\text{nV}/\sqrt{\text{Hz}}$
		$G = 100, R_S = 0\ \Omega, f = 1\text{ kHz}$		50		$\text{nV}/\sqrt{\text{Hz}}$
		$G = 100, R_S = 0\ \Omega, f = 0.1\text{ Hz to }10\text{ Hz}$		1		μV_{PP}
i_N	Input current noise	$f = 10\text{ Hz}$		100		$\text{fA}/\sqrt{\text{Hz}}$
		$f = 0.1\text{ Hz to }10\text{ Hz}$		2		pA_{PP}
GAIN						
G	Gain equation			$1 + (100\text{ k}\Omega/R_G)$		V/V
	Range of gain		1		1000	V/V
Gain error		$V_S = 5.5\text{ V}, (V-) + 100\text{ mV}$ $\leq V_O \leq (V+) - 100\text{ mV}$				
		$G = 1$		$\pm 0.01\%$	$\pm 0.1\%$	
		$G = 10$		$\pm 0.05\%$	$\pm 0.25\%$	
		$G = 100$		$\pm 0.07\%$	$\pm 0.25\%$	
	$G = 1000$		$\pm 0.25\%$	$\pm 0.5\%$		
	Gain vs temperature, $G = 1$	$T_A = -40^\circ\text{C to }+125^\circ\text{C}$		± 1	± 5	$\text{ppm}/^\circ\text{C}$
	Gain vs temperature, $G > 1$ ⁽⁴⁾	$T_A = -40^\circ\text{C to }+125^\circ\text{C}$		± 15	± 50	$\text{ppm}/^\circ\text{C}$
	Gain nonlinearity	$V_S = 5.5\text{ V}, (V-) + 100\text{ mV}$ $\leq V_O \leq (V+) - 100\text{ mV}$				
	Gain nonlinearity, $G = 1$ to 1000	$R_L = 10\text{ k}\Omega$		10		ppm
OUTPUT						
	Output voltage swing from rail	$V_S = 5.5\text{ V}, R_L = 10\text{ k}\Omega$		See Figure 29		50 mV
	Capacitive load drive			500		pF
I_{SC}	Short-circuit current	Continuous to common		-40, +5		mA

(1) Total V_{OS} , referred-to-input = $(V_{OSI}) + (V_{OSO} / G)$

(2) RTI = Referred-to-input

(3) 300-hour life test at 150°C demonstrated randomly distributed variation of approximately $1\ \mu\text{V}$

(4) Does not include effects of external resistor R_G

Electrical Characteristics (continued)

 for $V_S = 1.8\text{ V to }5.5\text{ V}$ at $T_A = 25^\circ\text{C}$, $R_L = 10\text{ k}\Omega$, $V_{REF} = V_S / 2$, and $G = 1$ (unless otherwise noted)

PARAMETER		TEST CONDITIONS	MIN	TYP	MAX	UNIT
FREQUENCY RESPONSE						
Bandwidth, -3dB		$G = 1$		150		kHz
		$G = 10$		35		kHz
		$G = 100$		3.5		kHz
		$G = 1000$		350		Hz
SR	Slew rate	$V_S = 5\text{ V}$, $V_O = 4\text{-V step}$, $G = 1$		0.16		V/ μs
		$V_S = 5\text{ V}$, $V_O = 4\text{-V step}$, $G = 100$		0.05		V/ μs
t_S	Settling time to 0.01%	$V_{STEP} = 4\text{ V}$, $G = 1$		50		μs
		$V_{STEP} = 4\text{ V}$, $G = 100$		400		μs
t_S	Settling time to 0.001%	$V_{STEP} = 4\text{ V}$, $G = 1$		60		μs
		$V_{STEP} = 4\text{ V}$, $G = 100$		500		μs
	Overload recovery	50% overdrive		75		μs
REFERENCE INPUT						
	R_{IN}			300		k Ω
	Voltage range		V-		V+	V
POWER SUPPLY						
Voltage range	Single voltage range		+1.8		+5.5	V
	Dual voltage range		± 0.9		± 2.75	V
I_Q	Quiescent current	$V_{IN} = V_S / 2$		50	75	μA
	vs temperature	$T_A = -40^\circ\text{C to }+125^\circ\text{C}$			80	μA
TEMPERATURE RANGE						
	Specified temperature range		-40		125	$^\circ\text{C}$
	Operating temperature range		-40		150	$^\circ\text{C}$

6.6 Typical Characteristics

at $T_A = 25^\circ\text{C}$, $V_S = 5\text{ V}$, $R_L = 10\text{ k}\Omega$, $V_{REF} = \text{midsupply}$, and $G = 1$ (unless otherwise noted)

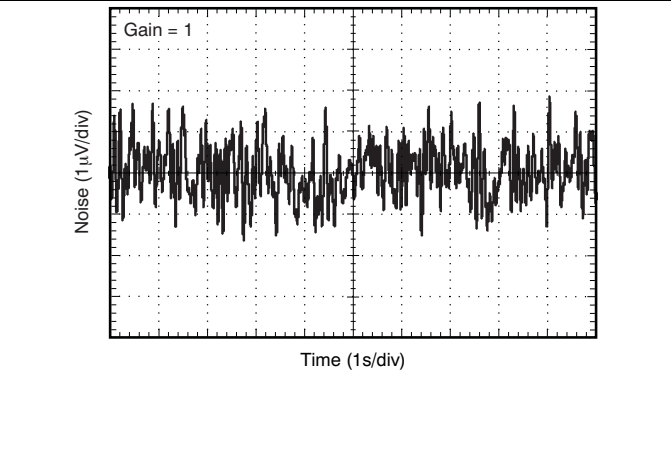
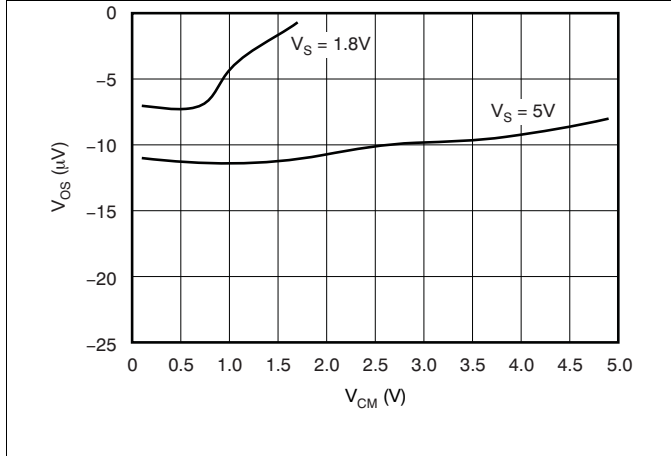
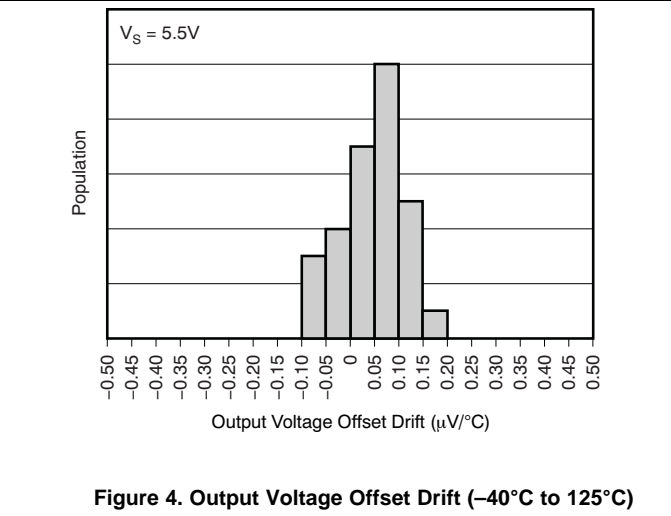
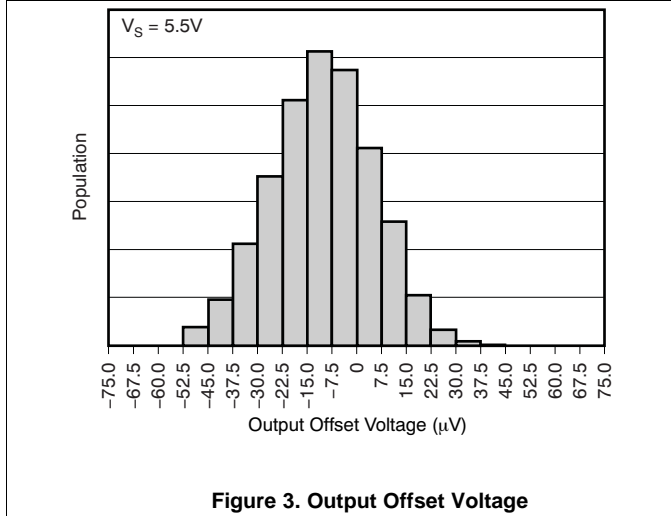
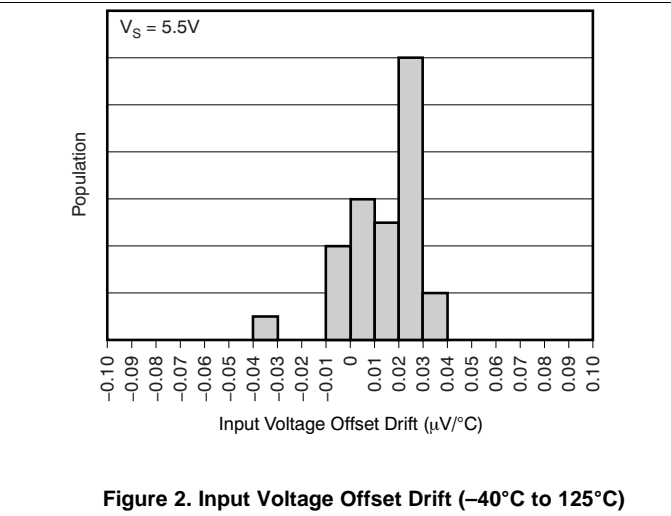
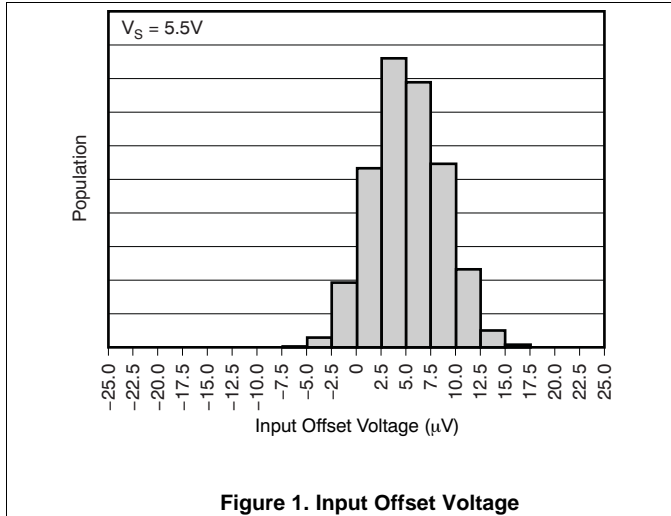

Typical Characteristics (continued)

at $T_A = 25^\circ\text{C}$, $V_S = 5\text{ V}$, $R_L = 10\text{ k}\Omega$, $V_{REF} = \text{midsupply}$, and $G = 1$ (unless otherwise noted)

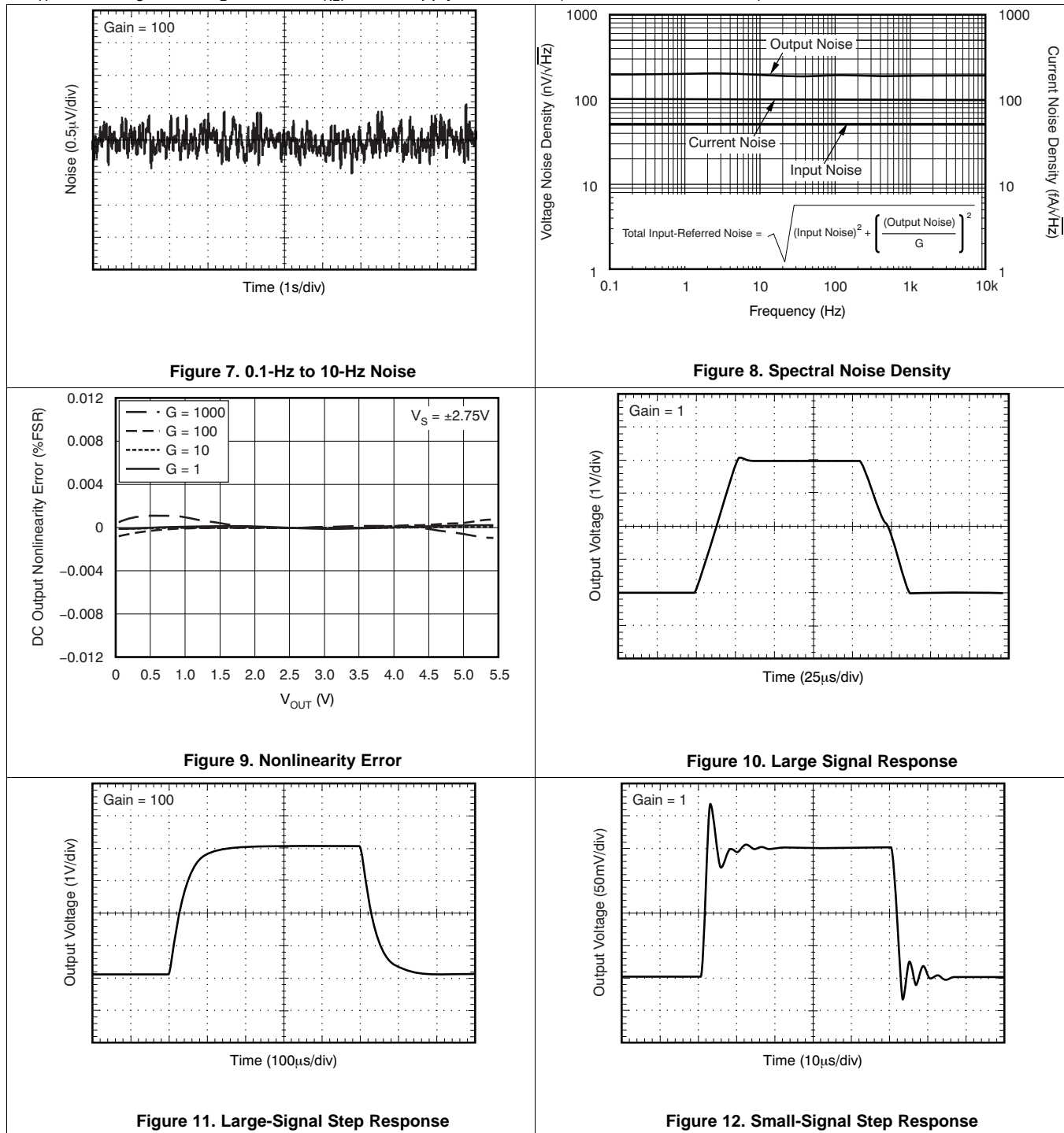

Typical Characteristics (continued)

at $T_A = 25^\circ\text{C}$, $V_S = 5\text{ V}$, $R_L = 10\text{ k}\Omega$, $V_{REF} = \text{mid supply}$, and $G = 1$ (unless otherwise noted)

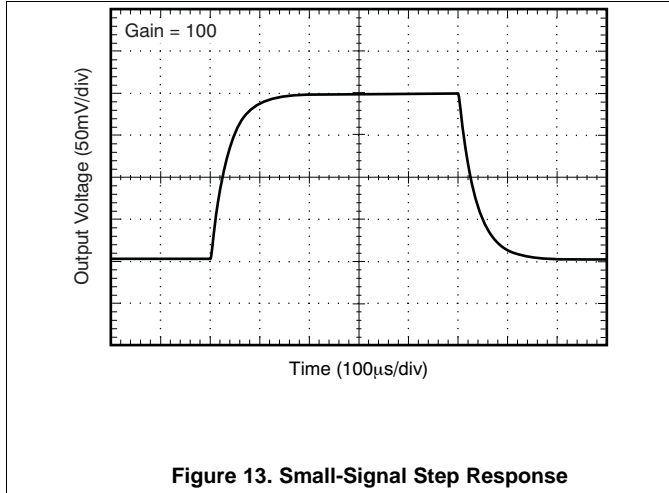

Figure 13. Small-Signal Step Response

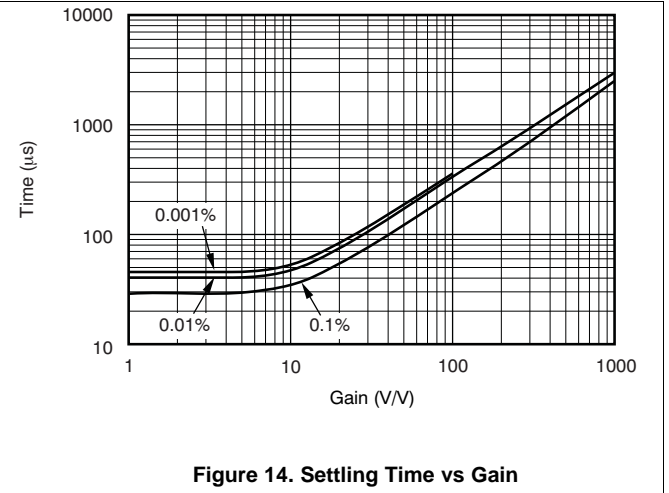

Figure 14. Settling Time vs Gain

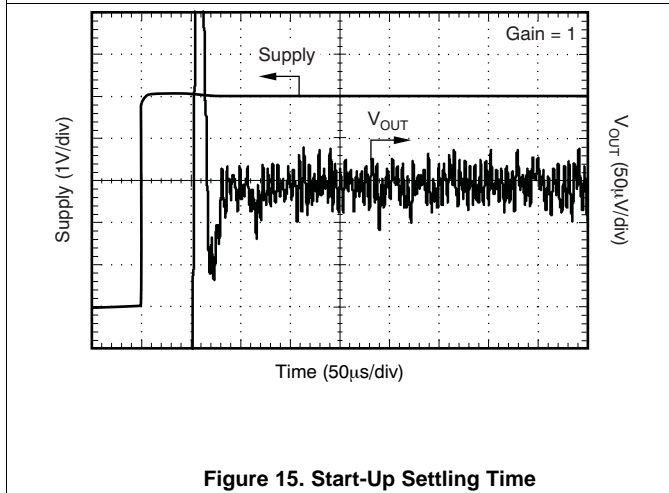

Figure 15. Start-Up Settling Time

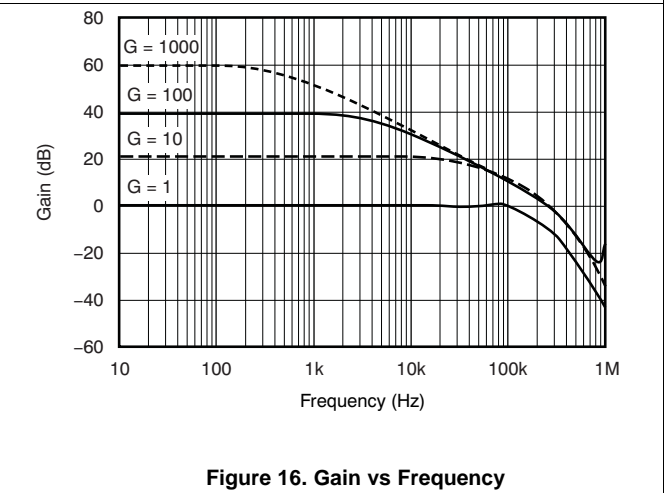

Figure 16. Gain vs Frequency

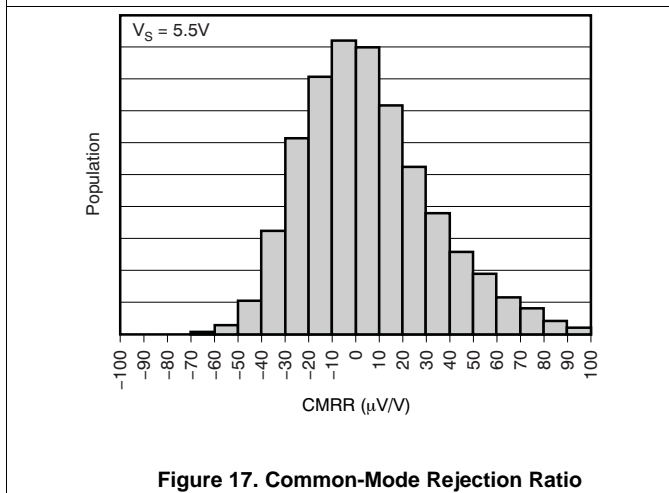

Figure 17. Common-Mode Rejection Ratio

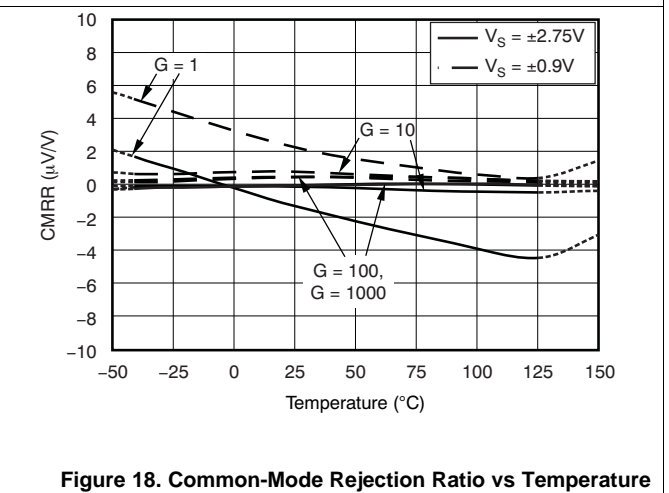

Figure 18. Common-Mode Rejection Ratio vs Temperature

Typical Characteristics (continued)

at $T_A = 25^\circ\text{C}$, $V_S = 5\text{ V}$, $R_L = 10\text{ k}\Omega$, $V_{REF} = \text{mid supply}$, and $G = 1$ (unless otherwise noted)

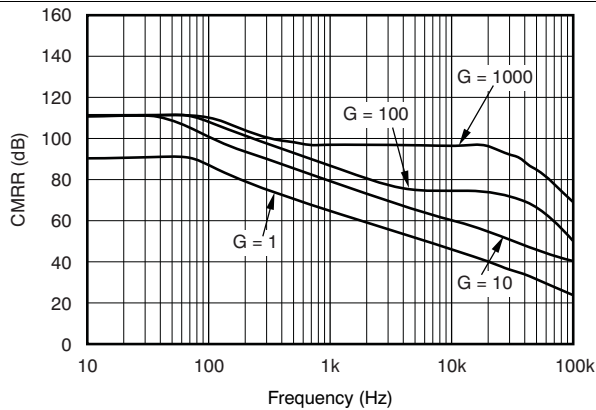

Figure 19. Common-Mode Rejection Ratio vs Frequency

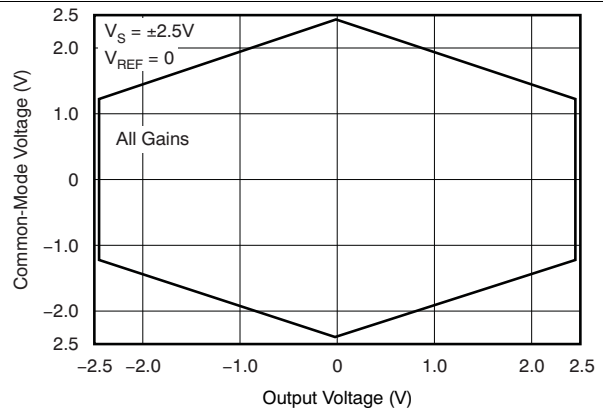

Figure 20. Typical Common-Mode Range vs Output Voltage

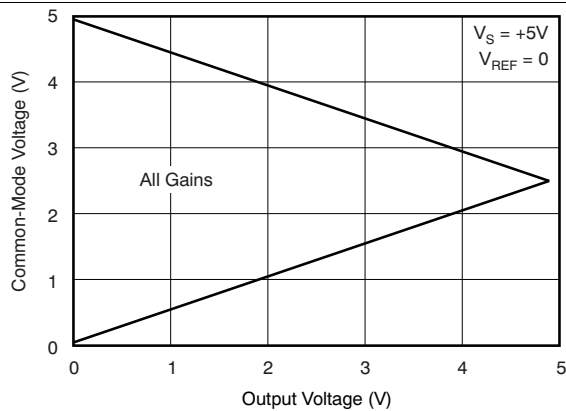

Figure 21. Typical Common-Mode Range vs Output Voltage

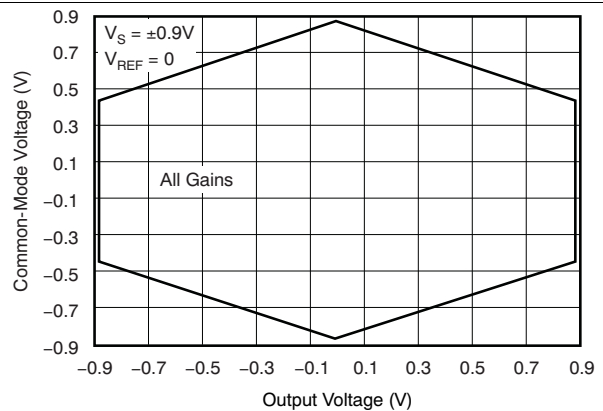

Figure 22. Typical Common-Mode Range vs Output Voltage

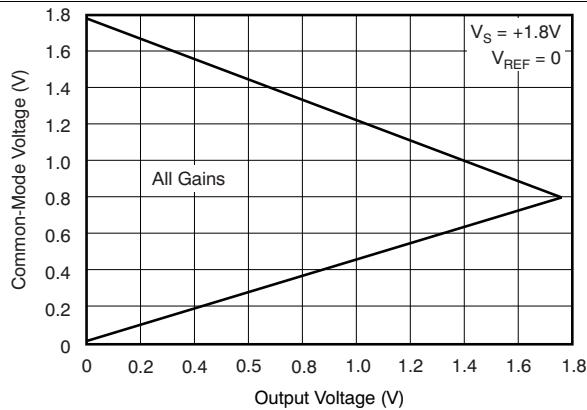

Figure 23. Typical Common-Mode Range vs Output Voltage

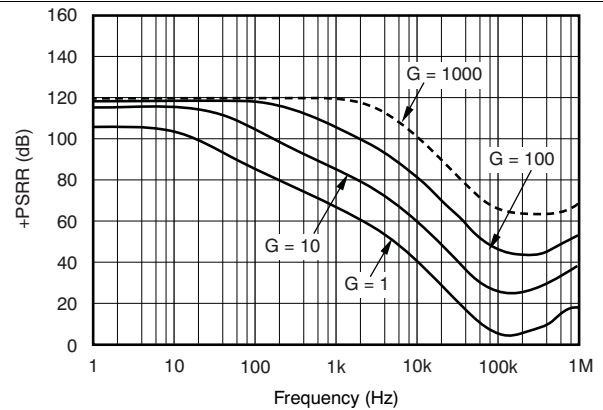

Figure 24. Positive Power-Supply Rejection Ratio

Typical Characteristics (continued)

at $T_A = 25^\circ\text{C}$, $V_S = 5\text{ V}$, $R_L = 10\text{ k}\Omega$, $V_{REF} = \text{mid supply}$, and $G = 1$ (unless otherwise noted)

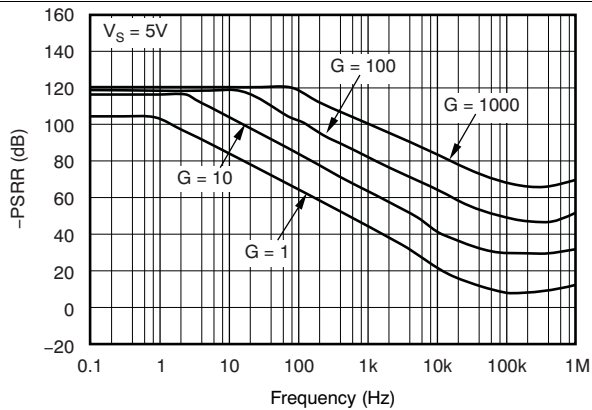

Figure 25. Negative Power-Supply Rejection Ratio

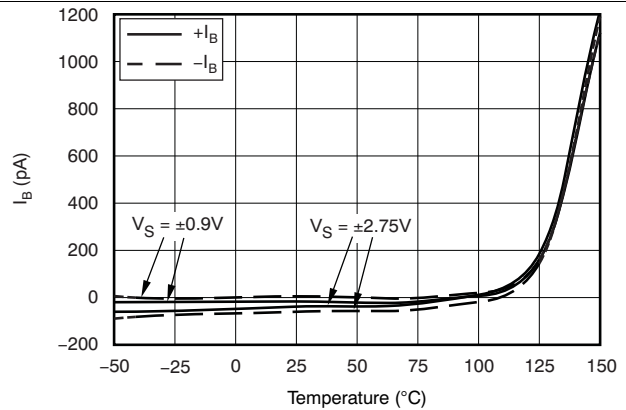

Figure 26. Input Bias Current vs Temperature

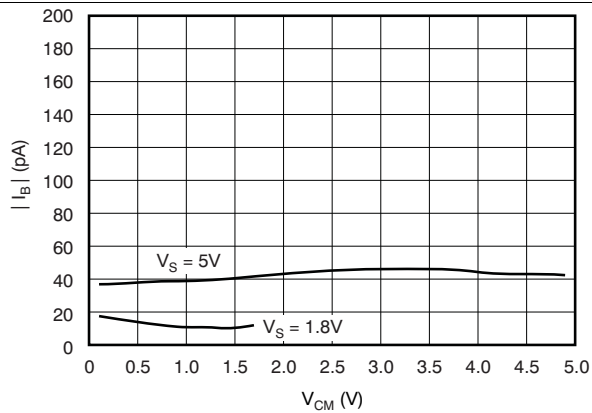

Figure 27. Input Bias Current vs Common-Mode Voltage

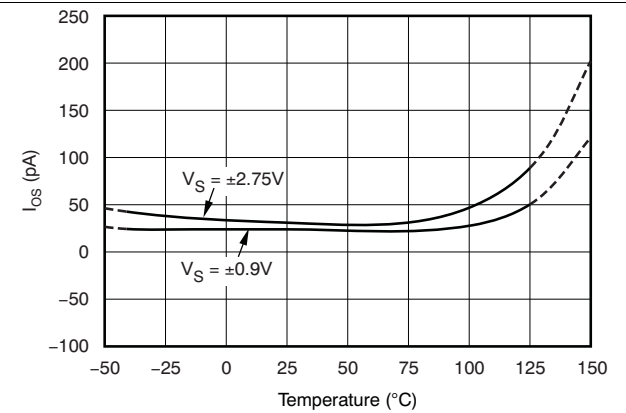

Figure 28. Input Offset Current vs Temperature

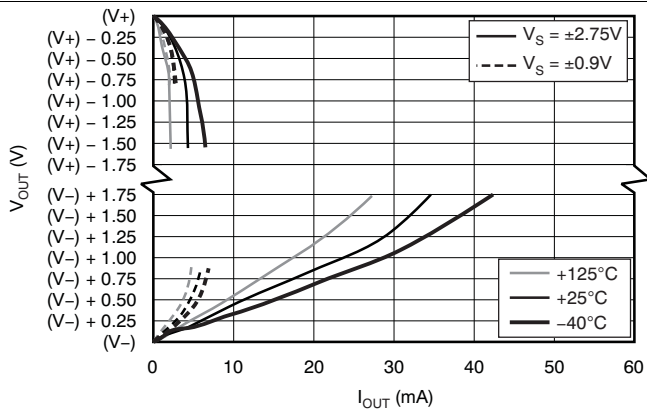

Figure 29. Output Voltage Swing vs Output Current

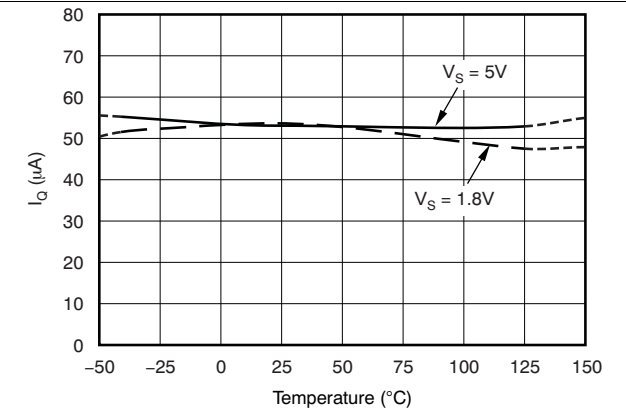
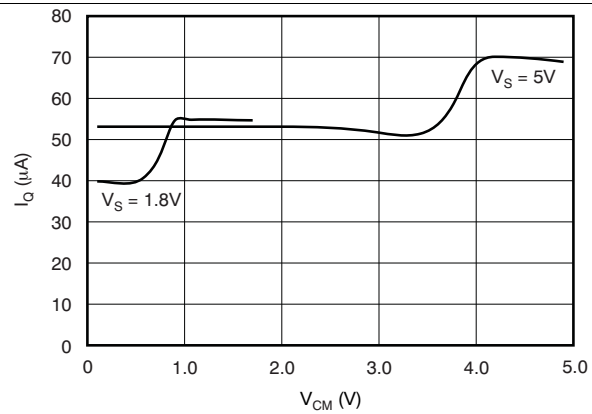

Figure 30. Quiescent Current vs Temperature

Typical Characteristics (continued)

 at $T_A = 25^\circ\text{C}$, $V_S = 5\text{ V}$, $R_L = 10\text{ k}\Omega$, $V_{\text{REF}} = \text{midsupply}$, and $G = 1$ (unless otherwise noted)

Figure 31. Quiescent Current vs Common-Mode Voltage

7 Detailed Description

7.1 Overview

The INA333 is a monolithic instrumentation amplifier (INA) based on the precision zero-drift OPA333 (operational amplifier) core. The INA333 also integrates laser-trimmed resistors to ensure excellent common-mode rejection and low gain error. The combination of the zero-drift amplifier core and the precision resistors allows this device to achieve outstanding DC precision and makes the INA333 ideal for many 3.3-V and 5-V industrial applications.

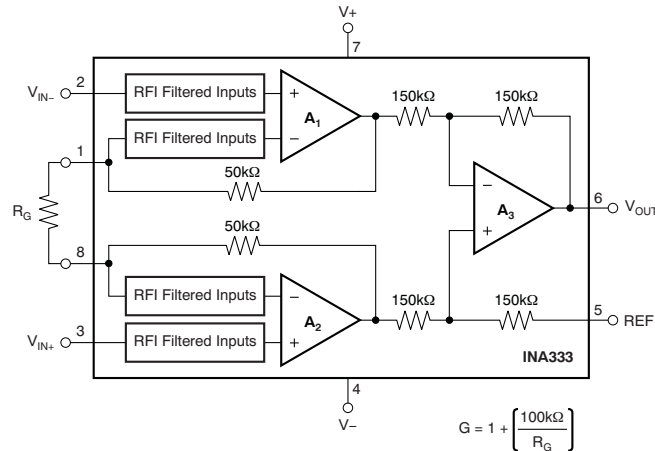
7.2 Functional Block Diagram



7.3 Feature Description

The INA333 is a low-power, zero-drift instrumentation amplifier offering excellent accuracy. The versatile three-operational-amplifier design and small size make the amplifiers ideal for a wide range of applications. Zero-drift chopper circuitry provides excellent DC specifications. A single external resistor sets any gain from 1 to 10,000. The INA333 is laser trimmed for very high common-mode rejection (100 dB at $G \geq 100$). This devices operate with power supplies as low as 1.8 V, and quiescent current of 50 μA , typically.

7.4 Device Functional Modes

7.4.1 Internal Offset Correction

INA333 internal operational amplifiers use an auto-calibration technique with a time-continuous 350-kHz operational amplifier in the signal path. The amplifier is zero-corrected every 8 μs using a proprietary technique. Upon power up, the amplifier requires approximately 100 μs to achieve specified VOS accuracy. This design has no aliasing or flicker noise.

7.4.2 Input Common-Mode Range

The linear input voltage range of the input circuitry of the INA333 is from approximately 0.1 V below the positive supply voltage to 0.1 V above the negative supply. As a differential input voltage causes the output voltage to increase, however, the linear input range is limited by the output voltage swing of amplifiers A1 and A2. Thus, the linear common-mode input range is related to the output voltage of the complete amplifier. This behavior also depends on supply voltage—see [Figure 20](#).

Input overload conditions can produce an output voltage that appears normal. For example, if an input overload condition drives both input amplifiers to the respective positive output swing limit, the difference voltage measured by the output amplifier is near zero. The output of the INA333 is near 0 V even though both inputs are overloaded.

8 Application and Implementation

NOTE

Information in the following applications sections is not part of the TI component specification, and TI does not warrant its accuracy or completeness. TI's customers are responsible for determining suitability of components for their purposes. Customers should validate and test their design implementation to confirm system functionality.

8.1 Application Information

The INA333 measures small differential voltage with high common-mode voltage developed between the noninverting and inverting input. The high input impedance makes the INA333 suitable for a wide range of applications. The ability to set the reference pin to adjust the functionality of the output signal offers additional flexibility that is practical for multiple configurations.

8.2 Typical Application

Figure 32 shows the basic connections required for operation of the INA333 device. Good layout practice mandates the use of bypass capacitors placed close to the device pins as shown.

The output of the INA333 device is referred to the output reference (REF) pin, which is normally grounded. This connection must be low-impedance to assure good common-mode rejection. Although 15 Ω or less of stray resistance can be tolerated while maintaining specified CMRR, small stray resistances of tens of Ωs in series with the REF pin can cause noticeable degradation in CMRR.

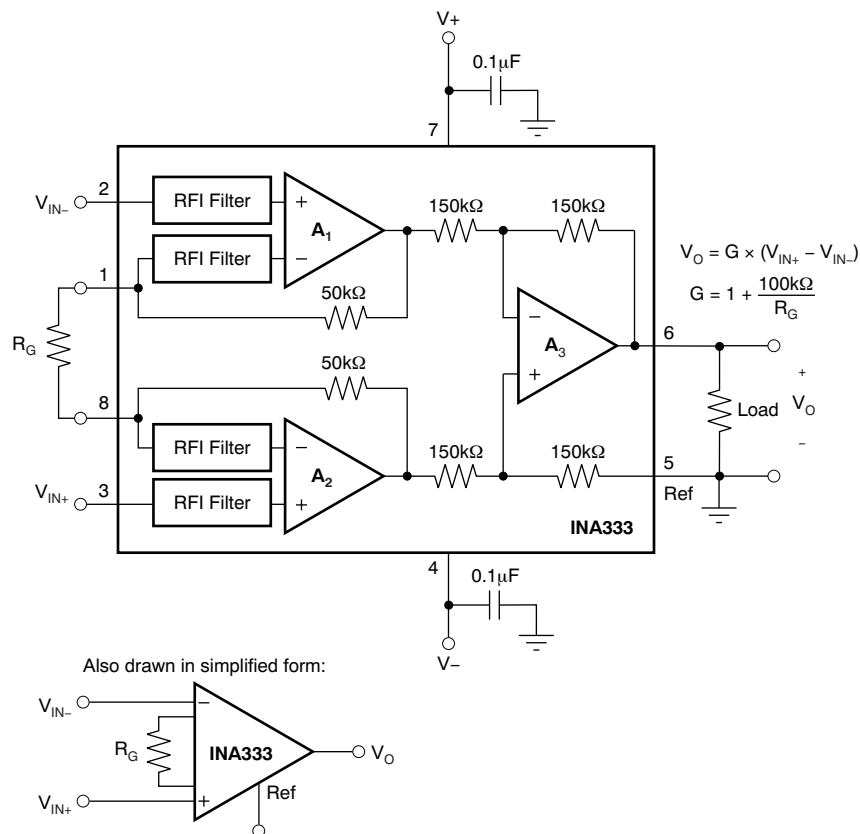

Figure 32. Basic Connections

Typical Application (continued)

8.2.1 Design Requirements

The device can be configured to monitor the input differential voltage when the gain of the input signal is set by the external resistor R_G . The output signal references to the Ref pin. The most common application is where the output is referenced to ground when no input signal is present by connecting the Ref pin to ground. When the input signal increases, the output voltage at the OUT pin increases, too.

8.2.2 Detailed Design Procedure

8.2.2.1 Setting the Gain

Gain of the INA333 device is set by a single external resistor, R_G , connected between pins 1 and 8. The value of R_G is selected according to [Equation 1](#):

$$G = 1 + (100 \text{ k}\Omega / R_G) \quad (1)$$

[Table 1](#) lists several commonly-used gains and resistor values. The 100 k Ω in [Equation 1](#) comes from the sum of the two internal feedback resistors of A_1 and A_2 . These on-chip resistors are laser trimmed to accurate absolute values. The accuracy and temperature coefficient of these resistors are included in the gain accuracy and drift specifications of the INA333 device.

The stability and temperature drift of the external gain setting resistor, R_G , also affects gain. The contribution of R_G to gain accuracy and drift can be directly inferred from the gain [Equation 1](#). Low resistor values required for high gain can make wiring resistance important. Sockets add to the wiring resistance and contribute additional gain error (possibly an unstable gain error) in gains of approximately 100 or greater. To ensure stability, avoid parasitic capacitance of more than a few picofarads at the R_G connections. Careful matching of any parasitics on both R_G pins maintains optimal CMRR over frequency.

Table 1. Commonly-Used Gains and Resistor Values

DESIRED GAIN	R_G (Ω)	NEAREST 1% R_G (Ω)
1	NC ⁽¹⁾	NC
2	100k	100k
5	25k	24.9k
10	11.1k	11k
20	5.26k	5.23k
50	2.04k	2.05
100	1.01k	1k
200	502.5	499
500	200.4	200
1000	100.1	100

(1) NC denotes no connection. When using the SPICE model, the simulation will not converge unless a resistor is connected to the R_G pins; use a very large resistor value.

8.2.2.2 Internal Offset Correction

The INA333 device internal operational amplifiers use an auto-calibration technique with a time-continuous 350-kHz operational amplifier in the signal path. The amplifier is zero-corrected every 8 μ s using a proprietary technique. Upon power-up, the amplifier requires approximately 100 μ s to achieve specified V_{OS} accuracy. This design has no aliasing or flicker noise.

8.2.2.3 Offset Trimming

Most applications require no external offset adjustment; however, if necessary, adjustments can be made by applying a voltage to the REF pin. [Figure 33](#) shows an optional circuit for trimming the output offset voltage. The voltage applied to REF pin is summed at the output. The operational amplifier buffer provides low impedance at the REF pin to preserve good common-mode rejection.

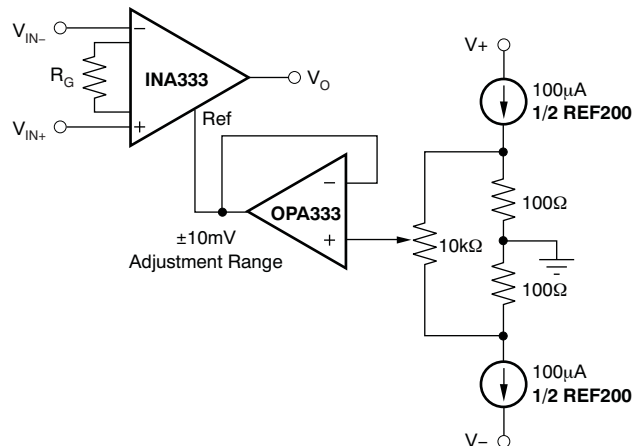

Figure 33. Optional Trimming of Output Offset Voltage

8.2.2.4 Noise Performance

The auto-calibration technique used by the INA333 device results in reduced low frequency noise, typically only $50 \text{ nV}/\sqrt{\text{Hz}}$, ($G = 100$). The spectral noise density can be seen in detail in [Figure 8](#). Low frequency noise of the INA333 device is approximately $1 \mu\text{V}_{\text{PP}}$ measured from 0.1 Hz to 10 Hz, ($G = 100$).

8.2.2.5 Input Bias Current Return Path

The input impedance of the INA333 device is extremely high—approximately 100 GΩ. However, a path must be provided for the input bias current of both inputs. This input bias current is typically $\pm 70 \text{ pA}$. High input impedance means that this input bias current changes very little with varying input voltage.

Input circuitry must provide a path for this input bias current for proper operation. [Figure 34](#) shows various provisions for an input bias current path. Without a bias current path, the inputs float to a potential that exceeds the common-mode range of the INA333 device, and the input amplifiers will saturate. If the differential source resistance is low, the bias current return path can be connected to one input (see the thermocouple example in [Figure 34](#)). With higher source impedance, using two equal resistors provides a balanced input with possible advantages of lower input offset voltage as a result of bias current and better high-frequency common-mode rejection.

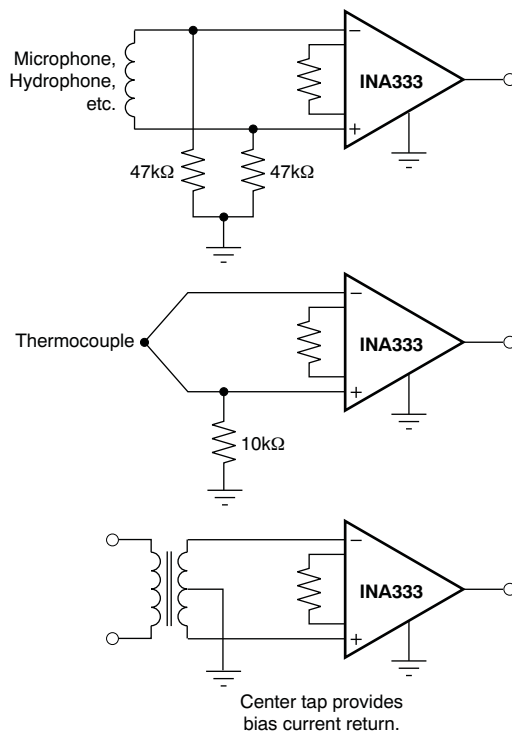

Figure 34. Providing an Input Common-Mode Current Path

8.2.2.6 Input Common-Mode Range

The linear input voltage range of the input circuitry of the INA333 device is from approximately 0.1 V below the positive supply voltage to 0.1 V above the negative supply. As a differential input voltage causes the output voltage to increase, however, the linear input range is limited by the output voltage swing of amplifiers A_1 and A_2 . Thus, the linear common-mode input range is related to the output voltage of the complete amplifier. This behavior also depends on supply voltage—see Figure 20 to Figure 23 in the *Typical Characteristics* section.

Input overload conditions can produce an output voltage that appears normal. For example, if an input overload condition drives both input amplifiers to the respective positive output swing limit, the difference voltage measured by the output amplifier is near zero. The output of the INA333 is near 0 V even though both inputs are overloaded.

8.2.2.7 Operating Voltage

The INA333 operates over a power-supply range of 1.8 V to 5.5 V (± 0.9 V to ± 2.75 V). Supply voltages higher than 7 V (absolute maximum) can permanently damage the device. Parameters that vary over supply voltage or temperature are shown in the *Typical Characteristics* section of this data sheet.

8.2.2.8 Low Voltage Operation

The INA333 device can be operated on power supplies as low as ± 0.9 V. Most parameters vary only slightly throughout this supply voltage range—see the *Typical Characteristics* section. Operation at very low supply voltage requires careful attention to assure that the input voltages remain within the linear range. Voltage swing requirements of internal nodes limit the input common-mode range with low power-supply voltage. Figure 20 to Figure 23 show the range of linear operation for various supply voltages and gains.

8.2.2.9 Single-Supply Operation

The INA333 device can be used on single power supplies of 1.8 V to 5.5 V. Figure 35 shows a basic single-supply circuit. The output REF pin is connected to mid-supply. Zero differential input voltage demands an output voltage of mid-supply. Actual output voltage swing is limited to approximately 50 mV more than ground, when the load is referred to ground as shown. Figure 29 shows how the output voltage swing varies with output current.

With single-supply operation, V_{IN+} and V_{IN-} must both be 0.1 V more than ground for linear operation. For instance, the inverting input cannot be connected to ground to measure a voltage connected to the noninverting input.

To show the issues affecting low voltage operation, consider the circuit in [Figure 35](#). It shows the INA333 device operating from a single 3-V supply. A resistor in series with the low side of the bridge assures that the bridge output voltage is within the common-mode range of the amplifier inputs.

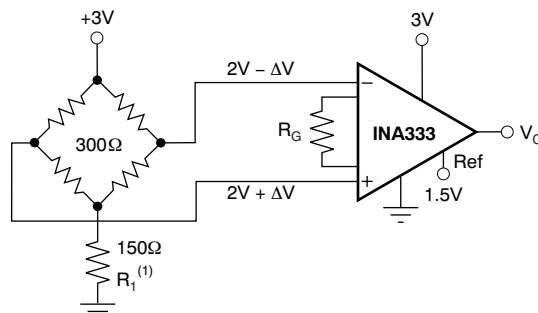

- (1) R_1 creates proper common-mode voltage, only for low-voltage operation—see [Single-Supply Operation](#).

Figure 35. Single-Supply Bridge Amplifier

8.2.2.10 Input Protection

The input pins of the INA333 device are protected with internal diodes connected to the power-supply rails. These diodes clamp the applied signal to prevent it from damaging the input circuitry. If the input signal voltage can exceed the power supplies by more than 0.3 V, the input signal current should be limited to less than 10 mA to protect the internal clamp diodes. This current limiting can generally be done with a series input resistor. Some signal sources are inherently current-limited and do not require limiting resistors.

8.2.3 Application Curves

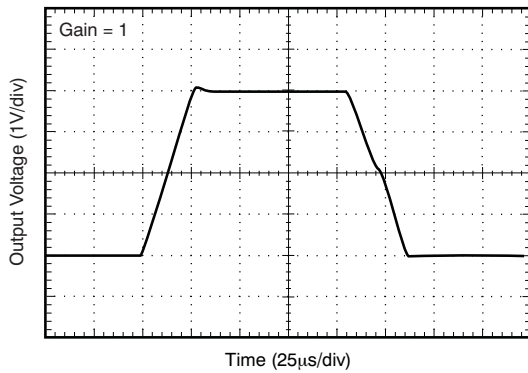

Figure 36. Large Signal Response

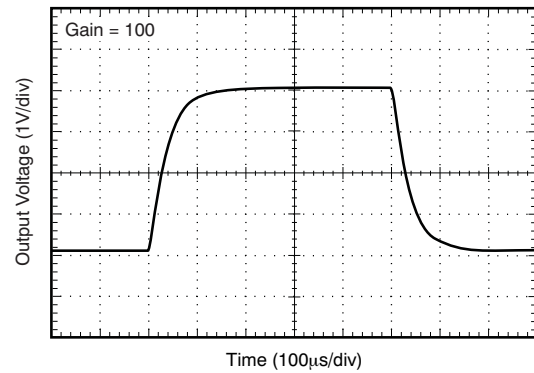

Figure 37. Large-Signal Step Response

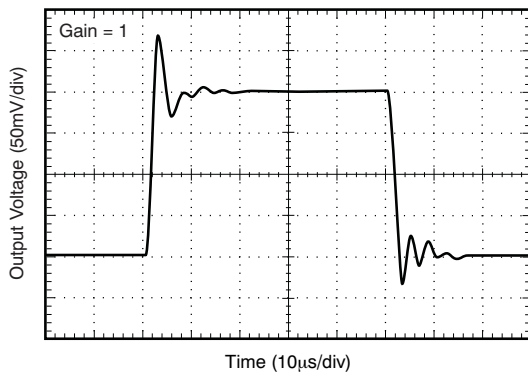

Figure 38. Small-Signal Step Response

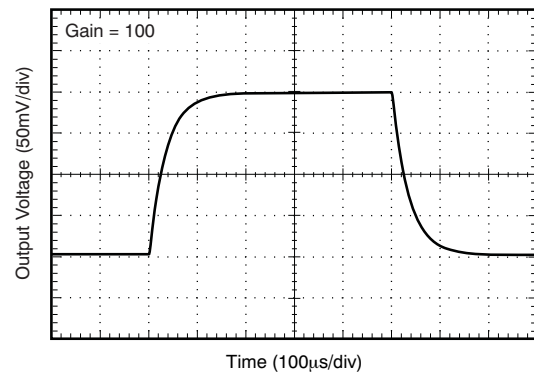

Figure 39. Small-Signal Step Response

9 Power Supply Recommendations

The minimum power supply voltage for INA333 is 1.8 V and the maximum power supply voltage is 5.5 V. For optimum performance, 3.3 V to 5 V is recommended. TI recommends adding a bypass capacitor at the input to compensate for the layout and power supply source impedance.

10 Layout

10.1 Layout Guidelines

Attention to good layout practices is always recommended. Keep traces short and, when possible, use a printed-circuit-board (PCB) ground plane with surface-mount components placed as close to the device pins as possible. Place a 0.1- μ F bypass capacitor closely across the supply pins. These guidelines should be applied throughout the analog circuit to improve performance and provide benefits such as reducing the electromagnetic-interference (EMI) susceptibility.

Instrumentation amplifiers vary in the susceptibility to radio-frequency interference (RFI). RFI can generally be identified as a variation in offset voltage or DC signal levels with changes in the interfering RF signal. The INA333 device has been specifically designed to minimize susceptibility to RFI by incorporating passive RC filters with an 8-MHz corner frequency at the V_{IN+} and V_{IN-} inputs. As a result, the INA333 device demonstrates remarkably low sensitivity compared to previous generation devices. Strong RF fields may continue to cause varying offset levels, however, and may require additional shielding.

10.2 Layout Example

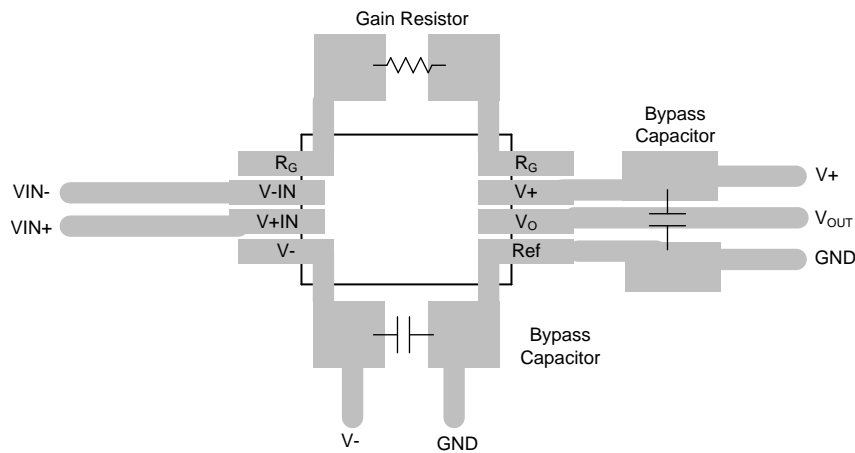

Figure 40. INA333 Layout

11 器件和文档支持

11.1 器件支持

11.1.1 开发支持

11.1.1.1 TINA-TI (免费下载软件)

TINA-TI 基于 SPICE 的模拟仿真程序 (适用于 INA333)

TINA 是一款简单、功能强大且易于使用的电路仿真程序，此程序基于 SPICE 引擎。TINA-TI 是 TINA 软件的一款免费全功能版本，除了一系列无源和有源模型外，此版本软件还预先载入了一个宏模型库。它提供所有传统的 SPICE 直流 (DC)、瞬态和频域分析以及其他设计功能。

TINA-TI 可从 [Analog eLab Design Center \(模拟电子实验室设计中心\)](#) 免费下载，它提供全面的后续处理能力，使得用户能够以多种方式形成结果。

虚拟仪器为用户提供选择输入波形和探测电路节点、电压和波形的功能，从而创建一个动态的快速入门工具。

图 41 和图 42 给出了适用于 INA333 器件的 TINA-TI 电路示例，这些电路可用于开发、修改和评估特定用途的电路设计。下面给出了这些仿真文件的下载链接。

注

必须安装 TINA 软件 (从 DesignSoft) 或者 TINA-TI 软件后才能使用这些文件。请从 TINA-TI 文件夹中下载免费的 TINA-TI 软件。

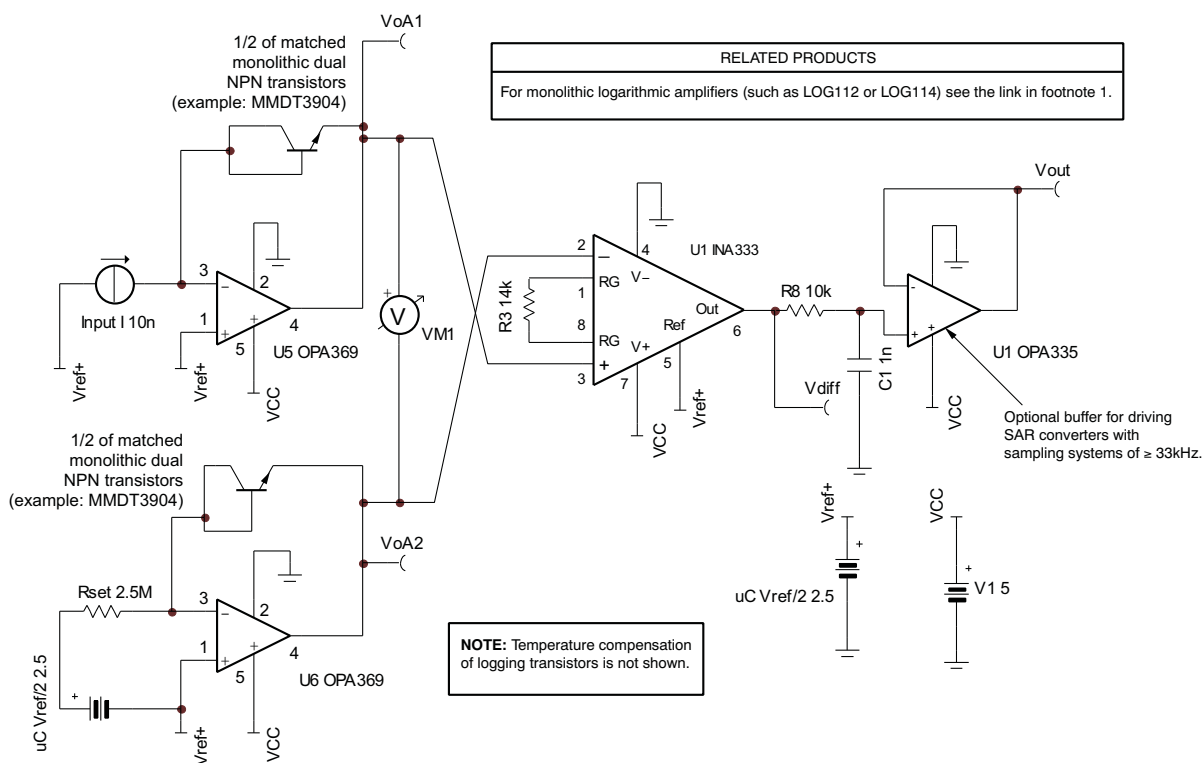

(1) 如下链接会打开 TI 对数放大器网页：对数放大器产品主页

图 41. 便携式电池供电类系统的低功耗对数函数电路 (例如血糖仪)

要下载包含此电路 TINA-TI 仿真文件的压缩文件，请点击如下链接：[对数电路](#)。

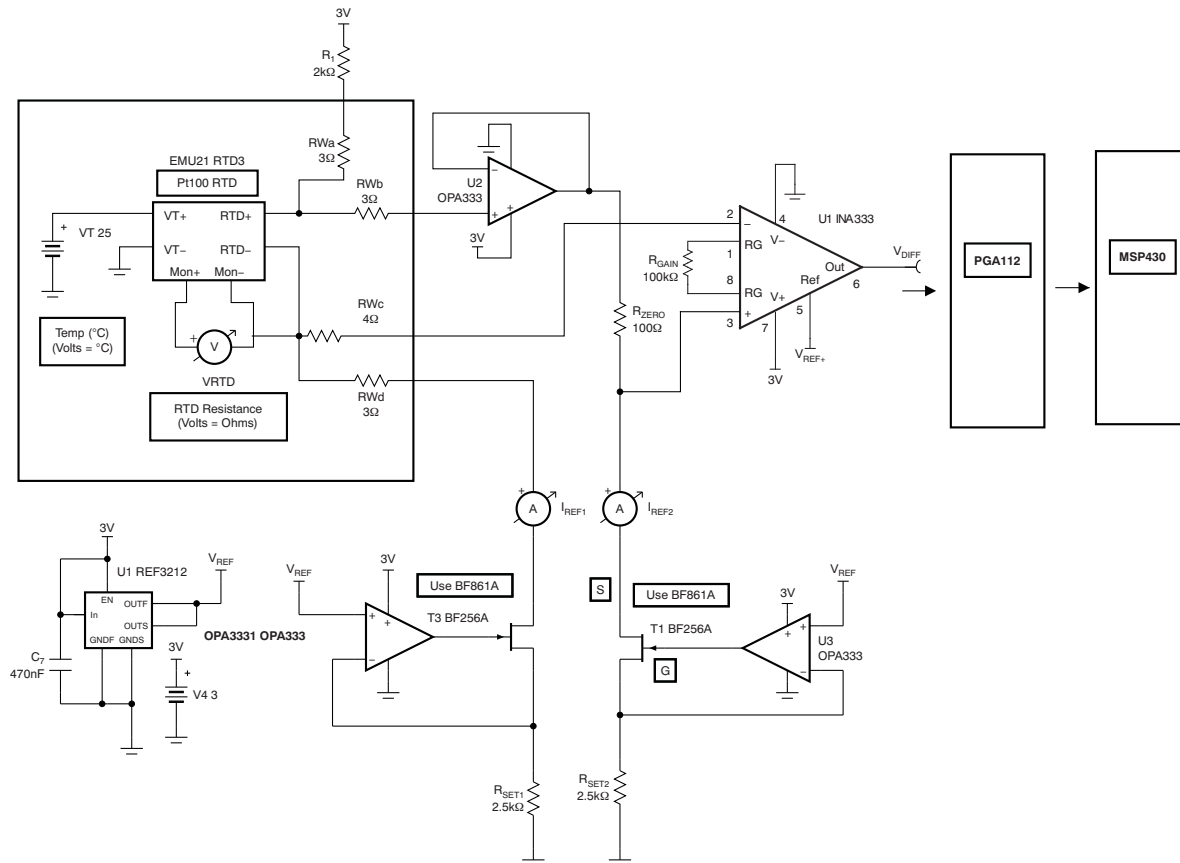
器件支持 (接下页)

RWa、RWb、RWc 和 RWd 用于仿真线电阻。包含这些电阻是为了展示四线传感技术对线不匹配问题的抗扰性。此方法假定使用四线 RTD。

图 42. 具有可编程增益采集系统的四线、3V PT100 RTD 调节器

要下载包含此电路 TINA-TI 仿真文件的压缩文件，请点击如下链接：[PT100 RTD](#)。

11.2 文档支持

11.2.1 相关文档

相关文档如下：

- 《高精度、低噪声、轨到轨输出、36V、零漂移运算放大器》，[SBOS642](#)
- 《50μV VOS、0.25μV/°C、35μA CMOS 运算放大器零漂移系列》，[SBOS432](#)
- 《4ppm/°C、100μA、SOT23-6 系列电压基准》，[SBVS058](#)
- 《电路板布局布线技巧》，[SLOA089](#)

11.3 商标

All trademarks are the property of their respective owners.

11.4 静电放电警告



这些装置包含有限的内置 ESD 保护。存储或装卸时，应将导线一起截短或将装置放置于导电泡棉中，以防止 MOS 门极遭受静电损伤。

11.5 Glossary

[SLYZ022](#) — *TI Glossary*.

This glossary lists and explains terms, acronyms, and definitions.

12 机械、封装和可订购信息

以下页中包括机械、封装和可订购信息。这些信息是针对指定器件可提供的最新数据。这些数据会在无通知且不对本文档进行修订的情况下发生改变。欲获得该数据表的浏览器版本，请查阅左侧的导航栏。

重要声明

德州仪器(TI)及其下属子公司有权根据 JESD46 最新标准,对所提供的产品和服务进行更正、修改、增强、改进或其它更改,并有权根据 JESD48 最新标准中止提供任何产品和服务。客户在下订单前应获取最新的相关信息,并验证这些信息是否完整且是最新的。所有产品的销售都遵循在订单确认时所提供的TI 销售条款与条件。

TI 保证其所销售的组件的性能符合产品销售时 TI 半导体产品销售条件与条款的适用规范。仅在 TI 保证的范围内,且 TI 认为有必要时才会使用测试或其它质量控制技术。除非适用法律做出了硬性规定,否则没有必要对每种组件的所有参数进行测试。

TI 对应用帮助或客户产品设计不承担任何义务。客户应对其使用 TI 组件的产品和应用自行负责。为尽量减小与客户产品和应用相关的风险,客户应提供充分的设计与操作安全措施。

TI 不对任何 TI 专利权、版权、屏蔽作品权或其它与使用了 TI 组件或服务的组合设备、机器或流程相关的 TI 知识产权中授予的直接或隐含权限作出任何保证或解释。TI 所发布的与第三方产品或服务有关的信息,不能构成从 TI 获得使用这些产品或服务的许可、授权、或认可。使用此类信息可能需要获得第三方的专利权或其它知识产权方面的许可,或是 TI 的专利权或其它知识产权方面的许可。

对于 TI 的产品手册或数据表中 TI 信息的重要部分,仅在没有对内容进行任何篡改且带有相关授权、条件、限制和声明的情况下才允许进行复制。TI 对此类篡改过的文件不承担任何责任或义务。复制第三方的信息可能需要服从额外的限制条件。

在转售 TI 组件或服务时,如果对该组件或服务参数的陈述与 TI 标明的参数相比存在差异或虚假成分,则会失去相关 TI 组件或服务的所有明示或暗示授权,且这是不正当的、欺诈性商业行为。TI 对任何此类虚假陈述均不承担任何责任或义务。

客户认可并同意,尽管任何应用相关信息或支持仍可能由 TI 提供,但他们将独立负责满足与其产品及其在应用中使用的 TI 产品相关的所有法律、法规和安全相关要求。客户声明并同意,他们具备制定与实施安全措施所需的全部专业技术和知识,可预见故障的危险后果、监测故障及其后果、降低有可能造成人身伤害的故障的发生机率并采取适当的补救措施。客户将全额赔偿因在此类安全关键应用中使用任何 TI 组件而对 TI 及其代理造成的任何损失。

在某些场合中,为了推进安全相关应用有可能对 TI 组件进行特别的促销。TI 的目标是利用此类组件帮助客户设计和创立其特有的可满足适用的功能安全性标准和要求的终端产品解决方案。尽管如此,此类组件仍然服从这些条款。

TI 组件未获得用于 FDA Class III (或类似的生命攸关医疗设备)的授权许可,除非各方授权官员已经达成了专门管控此类使用的特别协议。

只有那些 TI 特别注明属于军用等级或“增强型塑料”的 TI 组件才是设计或专门用于军事/航空应用或环境的。购买者认可并同意,对并非指定面向军事或航空航天用途的 TI 组件进行军事或航空航天方面的应用,其风险由客户单独承担,并且由客户独立负责满足与此类使用相关的所有法律和法规要求。

TI 已明确指定符合 ISO/TS16949 要求的产品,这些产品主要用于汽车。在任何情况下,因使用非指定产品而无法达到 ISO/TS16949 要求, TI 不承担任何责任。

	产品		应用
数字音频	www.ti.com.cn/audio	通信与电信	www.ti.com.cn/telecom
放大器和线性器件	www.ti.com.cn/amplifiers	计算机及周边	www.ti.com.cn/computer
数据转换器	www.ti.com.cn/dataconverters	消费电子	www.ti.com.cn/consumer-apps
DLP® 产品	www.dlp.com	能源	www.ti.com.cn/energy
DSP - 数字信号处理器	www.ti.com.cn/dsp	工业应用	www.ti.com.cn/industrial
时钟和计时器	www.ti.com.cn/clockandtimers	医疗电子	www.ti.com.cn/medical
接口	www.ti.com.cn/interface	安防应用	www.ti.com.cn/security
逻辑	www.ti.com.cn/logic	汽车电子	www.ti.com.cn/automotive
电源管理	www.ti.com.cn/power	视频和影像	www.ti.com.cn/video
微控制器 (MCU)	www.ti.com.cn/microcontrollers		
RFID 系统	www.ti.com.cn/rfidsys		
OMAP应用处理器	www.ti.com/omap		
无线连通性	www.ti.com.cn/wirelessconnectivity	德州仪器在线技术支持社区	www.deyisupport.com

邮寄地址: 上海市浦东新区世纪大道1568号, 中建大厦32楼邮政编码: 200122
Copyright © 2016, 德州仪器半导体技术(上海)有限公司

PACKAGING INFORMATION

Orderable Device	Status (1)	Package Type	Package Drawing	Pins	Package Qty	Eco Plan (2)	Lead/Ball Finish (6)	MSL Peak Temp (3)	Op Temp (°C)	Device Marking (4/5)	Samples
INA333AIDGKR	ACTIVE	VSSOP	DGK	8	2500	Green (RoHS & no Sb/Br)	CU NIPDAU CU NIPDAUAG	Level-2-260C-1 YEAR	-40 to 125	I333	Samples
INA333AIDGKRG4	ACTIVE	VSSOP	DGK	8	2500	Green (RoHS & no Sb/Br)	CU NIPDAUAG	Level-2-260C-1 YEAR	-40 to 125	I333	Samples
INA333AIDGKT	ACTIVE	VSSOP	DGK	8	250	Green (RoHS & no Sb/Br)	CU NIPDAU CU NIPDAUAG	Level-2-260C-1 YEAR	-40 to 125	I333	Samples
INA333AIDGKTG4	ACTIVE	VSSOP	DGK	8	250	Green (RoHS & no Sb/Br)	CU NIPDAUAG	Level-2-260C-1 YEAR	-40 to 125	I333	Samples
INA333AIDRGR	ACTIVE	SON	DRG	8	3000	Green (RoHS & no Sb/Br)	CU NIPDAU	Level-2-260C-1 YEAR	-40 to 125	I333A	Samples
INA333AIDRGT	ACTIVE	SON	DRG	8	250	Green (RoHS & no Sb/Br)	CU NIPDAU	Level-2-260C-1 YEAR	-40 to 125	I333A	Samples

(1) The marketing status values are defined as follows:

ACTIVE: Product device recommended for new designs.

LIFEBUY: TI has announced that the device will be discontinued, and a lifetime-buy period is in effect.

NRND: Not recommended for new designs. Device is in production to support existing customers, but TI does not recommend using this part in a new design.

PREVIEW: Device has been announced but is not in production. Samples may or may not be available.

OBSOLETE: TI has discontinued the production of the device.

(2) **RoHS:** TI defines "RoHS" to mean semiconductor products that are compliant with the current EU RoHS requirements for all 10 RoHS substances, including the requirement that RoHS substance do not exceed 0.1% by weight in homogeneous materials. Where designed to be soldered at high temperatures, "RoHS" products are suitable for use in specified lead-free processes. TI may reference these types of products as "Pb-Free".

RoHS Exempt: TI defines "RoHS Exempt" to mean products that contain lead but are compliant with EU RoHS pursuant to a specific EU RoHS exemption.

Green: TI defines "Green" to mean the content of Chlorine (Cl) and Bromine (Br) based flame retardants meet JS709B low halogen requirements of <=1000ppm threshold. Antimony trioxide based flame retardants must also meet the <=1000ppm threshold requirement.

(3) MSL, Peak Temp. - The Moisture Sensitivity Level rating according to the JEDEC industry standard classifications, and peak solder temperature.

(4) There may be additional marking, which relates to the logo, the lot trace code information, or the environmental category on the device.

(5) Multiple Device Markings will be inside parentheses. Only one Device Marking contained in parentheses and separated by a "~" will appear on a device. If a line is indented then it is a continuation of the previous line and the two combined represent the entire Device Marking for that device.

⁽⁶⁾ Lead/Ball Finish - Orderable Devices may have multiple material finish options. Finish options are separated by a vertical ruled line. Lead/Ball Finish values may wrap to two lines if the finish value exceeds the maximum column width.

Important Information and Disclaimer:The information provided on this page represents TI's knowledge and belief as of the date that it is provided. TI bases its knowledge and belief on information provided by third parties, and makes no representation or warranty as to the accuracy of such information. Efforts are underway to better integrate information from third parties. TI has taken and continues to take reasonable steps to provide representative and accurate information but may not have conducted destructive testing or chemical analysis on incoming materials and chemicals. TI and TI suppliers consider certain information to be proprietary, and thus CAS numbers and other limited information may not be available for release.

In no event shall TI's liability arising out of such information exceed the total purchase price of the TI part(s) at issue in this document sold by TI to Customer on an annual basis.

OTHER QUALIFIED VERSIONS OF INA333 :

NOTE: Qualified Version Definitions:

TAPE AND REEL INFORMATION

QUADRANT ASSIGNMENTS FOR PIN 1 ORIENTATION IN TAPE

*All dimensions are nominal

Device	Package Type	Package Drawing	Pins	SPQ	Reel Diameter (mm)	Reel Width W1 (mm)	A0 (mm)	B0 (mm)	K0 (mm)	P1 (mm)	W (mm)	Pin1 Quadrant
INA333AIDGKR	VSSOP	DGK	8	2500	330.0	12.4	5.3	3.4	1.4	8.0	12.0	Q1
INA333AIDGKT	VSSOP	DGK	8	250	330.0	12.4	5.3	3.4	1.4	8.0	12.0	Q1
INA333AIDRGR	SON	DRG	8	3000	330.0	12.4	3.3	3.3	1.1	8.0	12.0	Q2
INA333AIDRGT	SON	DRG	8	250	180.0	12.4	3.3	3.3	1.1	8.0	12.0	Q2

TAPE AND REEL BOX DIMENSIONS

*All dimensions are nominal

Device	Package Type	Package Drawing	Pins	SPQ	Length (mm)	Width (mm)	Height (mm)
INA333AIDGKR	VSSOP	DGK	8	2500	366.0	364.0	50.0
INA333AIDGKT	VSSOP	DGK	8	250	366.0	364.0	50.0
INA333AIDRGR	SON	DRG	8	3000	367.0	367.0	35.0
INA333AIDRGT	SON	DRG	8	250	210.0	185.0	35.0

DGK (S-PDSO-G8)

PLASTIC SMALL-OUTLINE PACKAGE

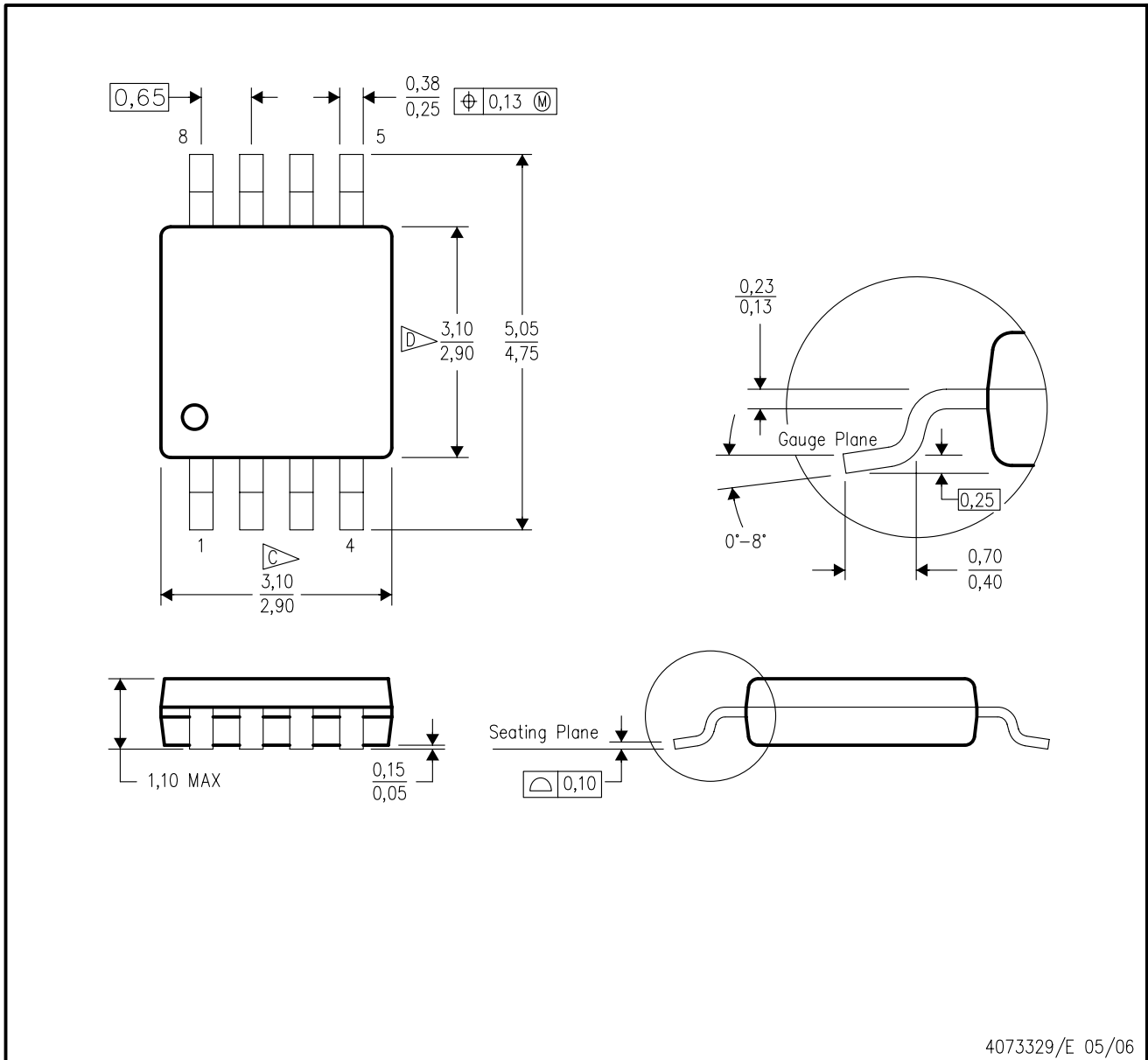

4073329/E 05/06

- NOTES:
- A. All linear dimensions are in millimeters.
 - B. This drawing is subject to change without notice.
 - C. Body length does not include mold flash, protrusions, or gate burrs. Mold flash, protrusions, or gate burrs shall not exceed 0.15 per end.
 - D. Body width does not include interlead flash. Interlead flash shall not exceed 0.50 per side.
 - E. Falls within JEDEC MO-187 variation AA, except interlead flash.



- NOTES:
- A. All linear dimensions are in millimeters.
 - B. This drawing is subject to change without notice.
 - C. Publication IPC-7351 is recommended for alternate designs.
 - D. Laser cutting apertures with trapezoidal walls and also rounding corners will offer better paste release. Customers should contact their board assembly site for stencil design recommendations. Refer to IPC-7525 for other stencil recommendations.
 - E. Customers should contact their board fabrication site for solder mask tolerances between and around signal pads.

DRG (S-PWSON-N8)

PLASTIC SMALL OUTLINE NO-LEAD

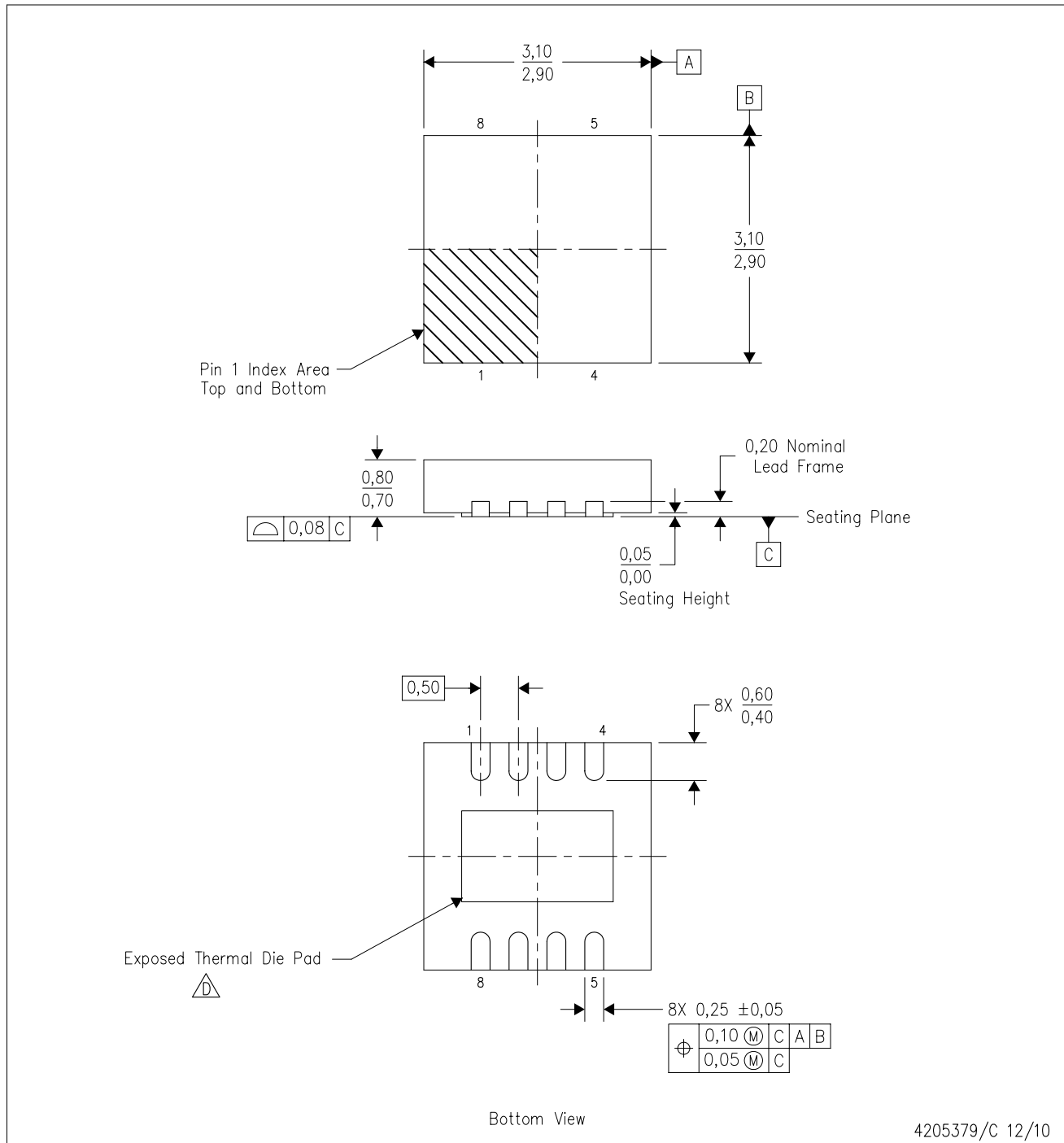

- NOTES:
- A. All linear dimensions are in millimeters. Dimensioning and tolerancing per ASME Y14.5M-1994.
 - B. This drawing is subject to change without notice.
 - C. SON (Small Outline No-Lead) package configuration.
 - D. The package thermal pad must be soldered to the board for thermal and mechanical performance. See the Product Data Sheet for details regarding the exposed thermal pad dimensions.
 - E. JEDEC MO-229 package registration pending.

THERMAL PAD MECHANICAL DATA

DRG (S-PWSON-N8)

PLASTIC SMALL OUTLINE NO-LEAD

THERMAL INFORMATION

This package incorporates an exposed thermal pad that is designed to be attached directly to an external heatsink. The thermal pad must be soldered directly to the printed circuit board (PCB). After soldering, the PCB can be used as a heatsink. In addition, through the use of thermal vias, the thermal pad can be attached directly to the appropriate copper plane shown in the electrical schematic for the device, or alternatively, can be attached to a special heatsink structure designed into the PCB. This design optimizes the heat transfer from the integrated circuit (IC).

For information on the Quad Flatpack No-Lead (QFN) package and its advantages, refer to Application Report, QFN/SON PCB Attachment, Texas Instruments Literature No. SLUA271. This document is available at www.ti.com.

The exposed thermal pad dimensions for this package are shown in the following illustration.

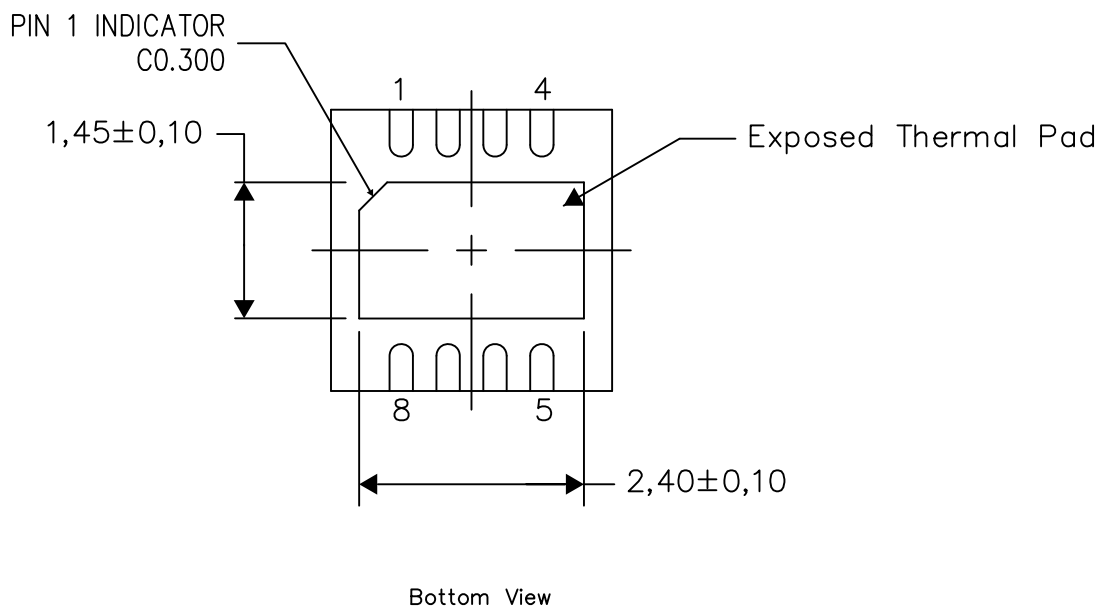

Exposed Thermal Pad Dimensions

4206881-3/1 03/15

NOTE: All linear dimensions are in millimeters

DRG (S-PWSON-N8)

PLASTIC SMALL OUTLINE NO-LEAD

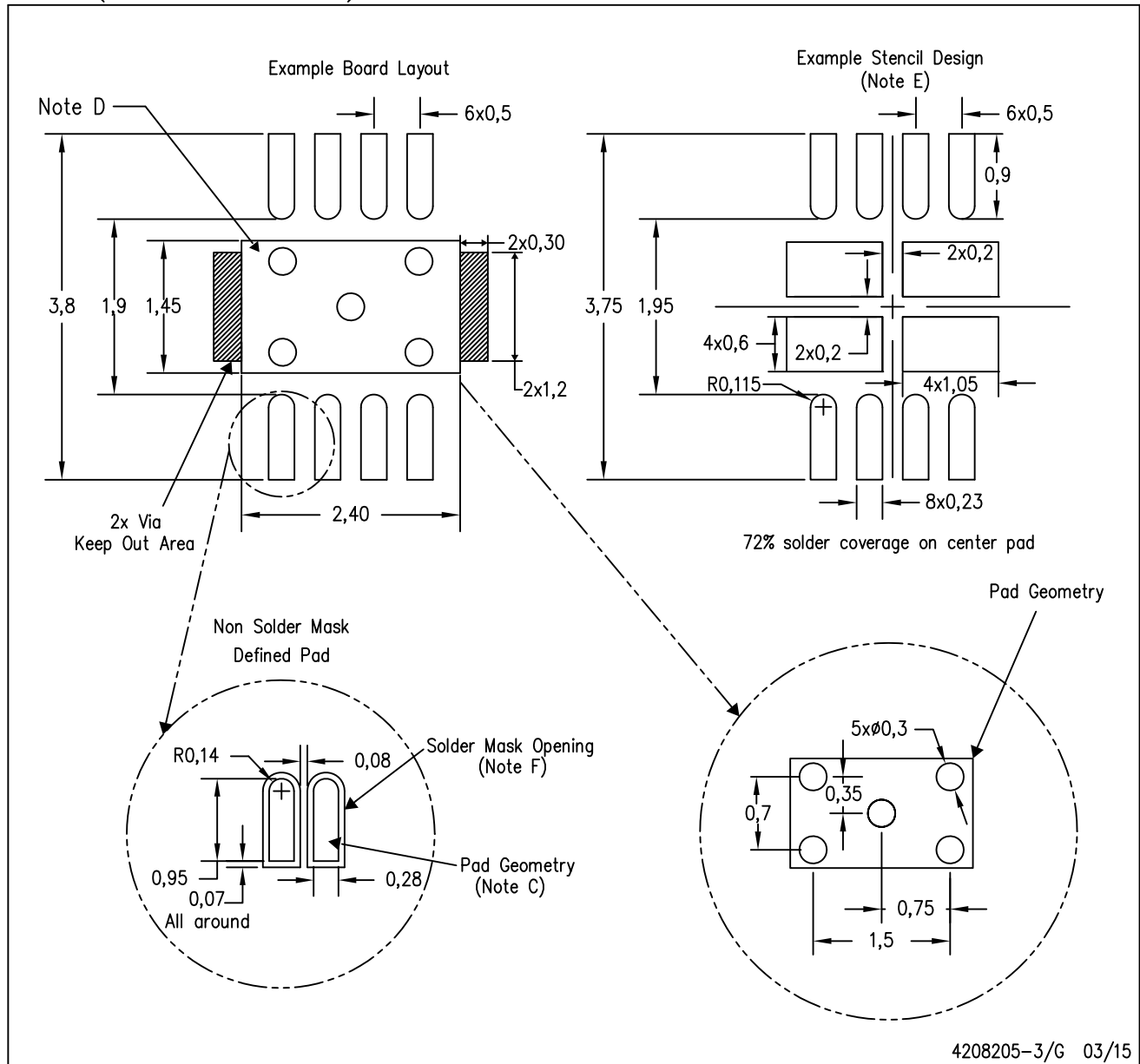

4208205-3/G 03/15

- NOTES:
- All linear dimensions are in millimeters.
 - This drawing is subject to change without notice.
 - Publication IPC-SM-782 is recommended for alternate designs.
 - This package is designed to be soldered to a thermal pad on the board. Refer to Application Note, Quad Flat-Pack Packages, Texas Instruments Literature No. SLUA271, and also the Product Data Sheets for specific thermal information, via requirements, and recommended board layout. These documents are available at www.ti.com <<http://www.ti.com>>.
 - Laser cutting apertures with trapezoidal walls and also rounding corners will offer better paste release. Customers should contact their board assembly site for stencil design recommendations. Refer to IPC 7525 for stencil design considerations.
 - Customers should contact their board fabrication site for minimum solder mask web tolerances between signal pads.

重要声明

德州仪器 (TI) 公司有权按照最新发布的 JESD46 对其半导体产品和服务进行纠正、增强、改进和其他修改，并不再按最新发布的 JESD48 提供任何产品和服务。买方在下订单前应获取最新的相关信息，并验证这些信息是否完整且是最新的。

TI 公布的半导体产品销售条款 (<http://www.ti.com/sc/docs/stdterms.htm>) 适用于 TI 已认证和批准上市的已封装集成电路产品的销售。另有其他条款可能适用于其他类型 TI 产品及服务的使用或销售。

复制 TI 数据表上 TI 信息的重要部分时，不得变更该等信息，且必须随附所有相关保证、条件、限制和通知，否则不得复制。TI 对该等复制文件不承担任何责任。第三方信息可能受到其它限制条件的制约。在转售 TI 产品或服务时，如果存在对产品或服务参数的虚假陈述，则会失去相关 TI 产品或服务的明示或暗示保证，且构成不公平的、欺诈性商业行为。TI 对此类虚假陈述不承担任何责任。

买方和在系统中整合 TI 产品的其他开发人员（总称“设计人员”）理解并同意，设计人员在设计应用时应自行实施独立的分析、评价和判断，且应全权负责并确保应用的安全性，及设计人员的应用（包括应用中使用的 TI 产品）应符合所有适用的法律法规及其他相关要求。设计人员就自己设计的应用声明，其具备制订和实施下列保障措施所需的一切必要专业知识，能够 (1) 预见故障的危险后果，(2) 监视故障及其后果，以及 (3) 降低可能导致危险的故障几率并采取适当措施。设计人员同意，在使用或分发包含 TI 产品的任何应用前，将彻底测试该等应用和该等应用中所用 TI 产品的功能。

TI 提供技术、应用或其他设计建议、质量特点、可靠性数据或其他服务或信息，包括但不限于与评估模块有关的参考设计和材料（总称“TI 资源”），旨在帮助设计人员开发整合了 TI 产品的应用，如果设计人员（个人，或如果是代表公司，则为设计人员的公司）以任何方式下载、访问或使用任何特定的 TI 资源，即表示其同意仅为该等目标，按照本通知的条款使用任何特定 TI 资源。

TI 所提供的 TI 资源，并未扩大或以其他方式修改 TI 对 TI 产品的公开适用的质保及质保免责声明；也未导致 TI 承担任何额外的义务或责任。TI 有权对其 TI 资源进行纠正、增强、改进和其他修改。除特定 TI 资源的公开文档中明确列出的测试外，TI 未进行任何其他测试。

设计人员只有在开发包含该等 TI 资源所列 TI 产品的应用时，才被授权使用、复制和修改任何相关 TI 资源。但并未依据禁止反言原则或其他法律授予您任何 TI 知识产权的任何其他明示或暗示的许可，也未授予您 TI 或第三方的任何技术或知识产权的许可，该等许可包括但不限于任何专利权、版权、屏蔽作品权或与美国 TI 产品或服务的任何整合、机器制作、流程相关的其他知识产权。涉及或参考了第三方产品或服务的信息不构成使用此类产品或服务的许可或与其相关的保证或认可。使用 TI 资源可能需要您向第三方获得对该等第三方专利或其他知识产权的许可。

TI 资源系“按原样”提供。TI 兹免除对资源及其使用作出所有其他明确或默认为的保证或陈述，包括但不限于对准确性或完整性、产权保证、无屡发故障保证，以及适销性、适合特定用途和不侵犯任何第三方知识产权的任何默认保证。TI 不负责任何申索，包括但不限于因组合产品所致或与之有关的申索，也不为或对设计人员进行辩护或赔偿，即使该等产品组合已列于 TI 资源或其他地方。对因 TI 资源或其使用引起或与之有关的任何实际的、直接的、特殊的、附带的、间接的、惩罚性的、偶发的、从属或惩戒性损害赔偿，不管 TI 是否获悉可能会产生上述损害赔偿，TI 概不负责。

除 TI 已明确指出特定产品已达到特定行业标准（例如 ISO/TS 16949 和 ISO 26262）的要求外，TI 不对未达到任何该等行业标准要求而承担任何责任。

如果 TI 明确宣称产品有助于功能安全或符合行业功能安全标准，则该等产品旨在帮助客户设计和创作自己的符合相关功能安全标准和要求的的应用。在应用内使用产品的行为本身不会配有安全特性。设计人员必须确保遵守适用于其应用的相关安全要求和标准。设计人员不可将任何 TI 产品用于关乎性命的医疗设备，除非已由各方获得授权的管理人员签署专门的合同对此类应用专门作出规定。关乎性命的医疗设备是指出现故障会导致严重身体伤害或死亡的医疗设备（例如生命保障设备、心脏起搏器、心脏除颤器、人工心脏泵、神经刺激器以及植入设备）。此类设备包括但不限于，美国食品药品监督管理局认定为 III 类设备的设备，以及在美国以外的其他国家或地区认定为同等类别设备的所有医疗设备。

TI 可能明确指定某些产品具备某些特定资格（例如 Q100、军用级或增强型产品）。设计人员同意，其具备一切必要专业知识，可以为自己的应用选择适合的产品，并且正确选择产品的风险由设计人员承担。设计人员单方面负责遵守与该等选择有关的所有法律或监管要求。

设计人员同意向 TI 及其代表全额赔偿因其不遵守本通知条款和条件而引起的任何损害、费用、损失和/或责任。

邮寄地址：上海市浦东新区世纪大道 1568 号中建大厦 32 楼，邮政编码：200122
Copyright © 2017 德州仪器半导体技术（上海）有限公司