

Schematic:

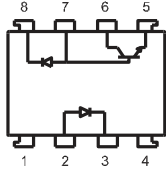

For dimensions and pin-outs, see the last page of this document.

Features:

1. High speed response t_{PLH} , t_{PHL} (MAX.1.5us at $R_L=4.1k\Omega$)
2. High common mode rejection voltage (CM:TYP.1kV/us)
3. Standard dual-in-line package

Ordering:

Suffix to Standard Part Number

- V = VDE Approved
- G = 10mm Lead Spread
- S = Surface Mount Lead-form
- T = Tape & Reel

Applications:

- Computers,measuring instruments, control equipment.
- High speed line receivers high speed logic.
- Telephone sets.
- Signal transmission between circuits of different potentials and impedances.

Absolute Maximum Ratings:

($T_a=25^\circ\text{C}$)

Parameter		Symbol	Rating	Unit
Input	Forward current	I_F	25	mA
	*1 Peak forward current	I_F	50	mA
	*2 Peak transient forward current	I_{FM}	1	A
	Reverse voltage	V_R	5	V
	Power dissipation	P	45	mW
Output	Supply voltage	V_{CC}	-0.5 to 15	V
	Output voltage	V_O	-0.5 to 15	V
	Emitter-base reverse with-stand voltage (Pin 5 to 7)	V_{EBO}	5	V
	Average output current	I_O	8	mA
	Peak output current	I_{OP}	16	mA
	Base current (Pin 7)	I_B	5	mA
	Power dissipation	P_O	100	mW
*3 Isolation voltage 1 minute		V_{ISO}	2500	V _{rms}
Operating temperature		T_{OPR}	-55 to +100	$^\circ\text{C}$
Storage temperature		T_{STG}	-55 to +125	$^\circ\text{C}$
*4 Soldering temperature		T_{SOL}	260	$^\circ\text{C}$

*1 50% duty cycle,Pulse width : 1mS
Decreases at the rate of 1.6mA/ $^\circ\text{C}$ if the external temperature is 70 $^\circ\text{C}$ or more.

*2 Pulse width<=1uS,300pulse/sec

*3 40 to 60% RH,AC for 1 minute

*4 For 10 seconds



Electrical Characteristics:

(Ta=0 to +70°C unless otherwise specified)

Parameter	Symbol	Conditions	MIN.	TYP.	MAX.	Unit
*5 Current transfer ratio	CTR (1)	Ta= 25°C , I _F =16mA Vo = 0.4V , Vcc = 4.5V	7	40	-	%
	CTR (2)	I _F =16mA Vo = 0.5V , Vcc = 4.5V	5	43	-	%
Logic (0) output voltage	VoL	*6 Vcc = 4.5V, I _F =16mA	-	0.1	0.4	V
Logic (1) output current	I _{OH} (1)	Ta= 25°C , I _F =0 Vo = Vcc = 5.5V	-	3.0	500	nA
	I _{OH} (2)	Ta= 25°C , I _F =0 Vo = Vcc = 15V	-	0.01	1.0	uA
	I _O (8)	Vcc = Vo = 15V, I _F = 0	-	-	50	uA
Logic (0) supply current	I _{CCL}	I _F = 16mA Vo = open , Vcc = 15V	-	200	-	uA
Logic (1) supply current	I _{CCH} (1)	Ta= 25°C , I _O =0 Vf = open , Vcc = 15V	-	0.02	1.0	uA
	I _{CCH} (2)	I _O =0 Vo = open , Vcc = 15V	-	-	2.0	uA
Input forward voltage	V _F	Ta= 25°C , I _F = 16mA	-	1.7	1.95	V
Input forward voltage temperature coefficient	ΔV _F /ΔTa	I _F = 16mA	-	-1.9	-	mV/°C
Input reverse voltage	BAR	Ta=25°C , I _R =10uA	5.0	-	-	V
Input capacitance	C _{IN}	V _F =0 , f=1MHz	-	60	-	pF
*7 Leak current(input-output)	I _{LO}	Ta= 25°C , 45 % RH V _{LO} =3kVDC , t = 5s	-	-	1.0	uA
*7 Isolation resistance(input-output)	R _{LO}	V _{LO} =500VDC	-	10 ¹²	-	Ω
*7 Capacitance(input-output)	C _{LO}	f=1MHz	-	0.6	-	pF
Transistor current amplification factor	h _{FE}	Vo = 5V , Io = 3mA	-	70	-	

*5 Current transfer ratio is the ratio of input current and output current expressed in %

*6 Io = 1.1mA

*7 Measured as 2-pin element (Short 1,2,3,4 and 5,6,7,8)

Switching Characteristics

(Ta=25°C, Vcc=5V, I_F=16mA)

Parameter	Symbol	Conditions	MIN.	TYP.	MAX.	Unit
*8 *9 Propagation delay time Output (1)→(0)	t _{PHL}	R _L = 4.1kΩ	-	0.3	1.5	uS
*8 *9 Propagation delay time Output (0)→(1)	t _{PLH}	R _L = 4.1kΩ	-	0.4	1.5	uS
*10 *11 Instantaneous common mode rejection voltage "Output (1)"	CMH	I _F =0, V _C =10V _{pp}	-	1000	-	V/uS
*10 *11 Instantaneous common mode rejection voltage "Output (0)"	CM _L	I _F =16mA, V _{CM} =10V _{pp}	-	-1000	-	V/uS
*12 Bandwidth	BW	R _L = 100Ω	-	2.0	-	MHz

*8 R_L = 4.1kΩ is equivalent to one LSTTL and 6.1kΩ pull-up resistor.

*10 Instantaneous common mode rejection voltage "output(1)" represents a common mode voltage variation that can hold the output above (1) level (Vo > 2.0V)
Instantaneous common mode rejection voltage "output(0)" represents a common mode voltage variation that can hold the output above (0) level (Vo < 0.8V)

*12 Bandwidth represents a point where AC input goes down by 3dB.

*9 Tset Circuit Propagation Delay Time

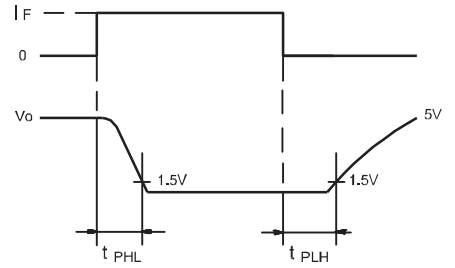
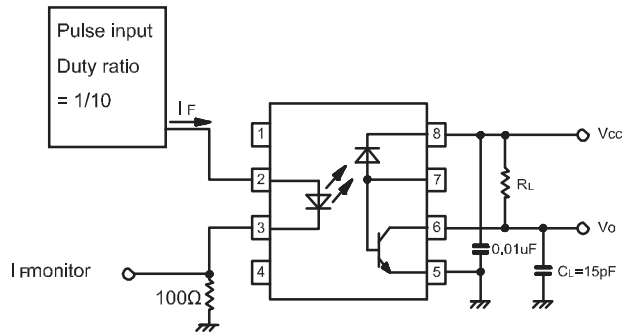

*11 Tset Circuit for Instantaneous Common Mode Rejection Voltage

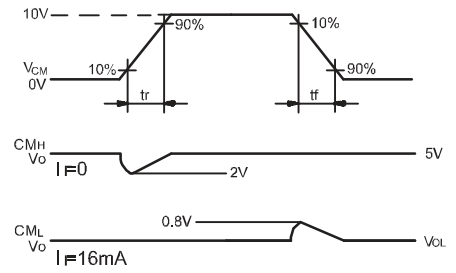
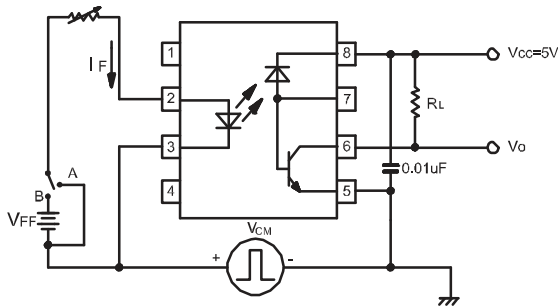

Fig.7 : 8-pin DIP type

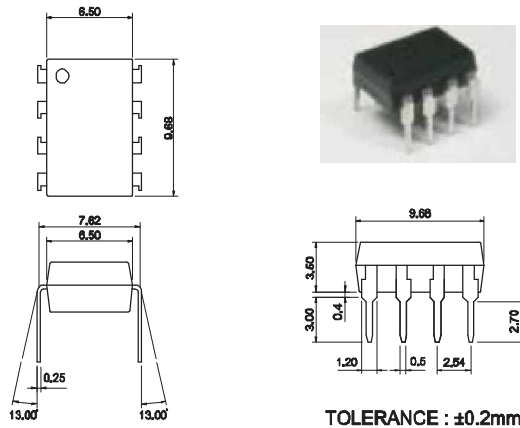

Fig.8 : 8-pin SMD type

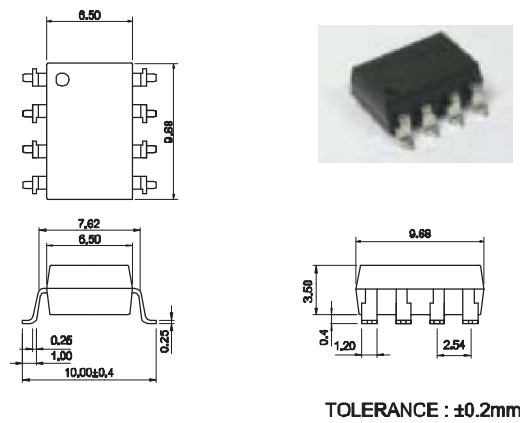
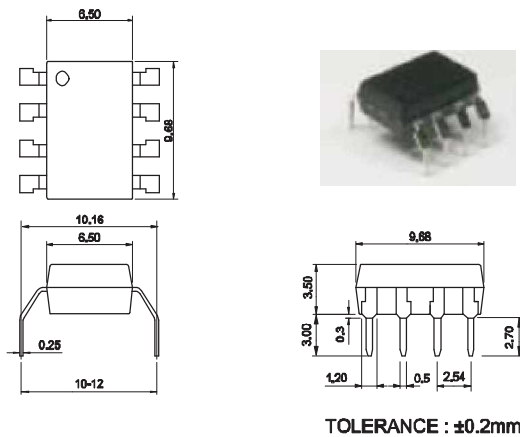

Fig.9 : 8-pin G type



This datasheet has been downloaded from:

www.EEworld.com.cn

Free Download

Daily Updated Database

100% Free Datasheet Search Site

100% Free IC Replacement Search Site

Convenient Electronic Dictionary

Fast Search System

www.EEworld.com.cn