



±2g/±4g/±8g Three Axis Low-g Digital Output Accelerometer

The MMA7455L is a Digital Output (I²C/SPI), low power, low profile capacitive micromachined accelerometer featuring signal conditioning, a low pass filter, temperature compensation, self test, configurable to detect 0g through interrupt pins (INT1 or INT2), and pulse (click) detect for quick motion detection. The 0g offset can be customer calibrated using assigned 0g registers and g-Select which allows for command selection for 3 sensitivities (2g/4g/8g). Zero-g offset and sensitivity are factory set and require no external devices. The MMA7455L includes a Standby Mode that makes it ideal for handheld battery powered electronics.

Features

- Digital Output (I²C/SPI) - 10-Bit at 8g Mode
- 3mm x 5mm x 1mm LGA-14 Package
- Low Current Consumption: 400 µA
- Self Test for Z-Axis
- Low Voltage Operation: 2.4 V – 3.6 V
- User Assigned Registers for Offset Calibration
- Programmable Threshold Interrupt Output
- Level/Click Detection for Motion Recognition (Shock, Vibration, Freefall)
- Pulse Detection for Single or Double Pulse Recognition
- Sensitivity (64 LSB/g @ 2g and @ 8g in 10-Bit Mode)
- Selectable Sensitivity (±2g, ±4g, ±8g)
- Robust Design, High Shocks Survivability (10,000 g)
- RoHS Compliant
- Environmentally Preferred Product
- Low Cost

Typical Applications

- Cell Phone/PMP/PDA: Image Stability, Text Scroll, Motion Dialing, E-Compass, Tap to Mute
- HDD: Freefall Detection
- Laptop PC: Freefall Detection, Anti-Theft
- Navigation and Dead Reckoning: Position Detection, Pedometer
- E-Compass Tilt Compensation
- 3D Gaming: Tilt and Motion Sensing, Event Recorder

ORDERING INFORMATION			
Part Number	Temperature Range	Package	Shipping
MMA7455LT	-40 to +85°C	LGA-14	Tray
MMA7455LR1	-40 to +85°C	LGA-14	Tape & Reel (7" Reel)
MMA7455LR2	-40 to +85°C	LGA-14	Tape & Reel (13" Reel)

MMA7455L

MMA7455L: XYZ AXIS ACCELEROMETER ±2G/±4G/±8G

Bottom View

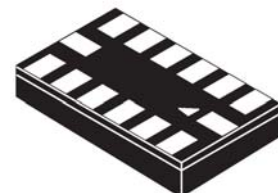

14 LEAD
 LGA
 CASE 1977-01

Top View

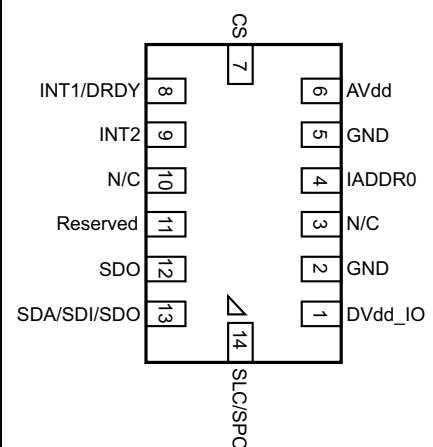

Figure 1. Pin Connections

This document contains certain information on a new product. Specifications and information herein are subject to change without notice.

PIN DESCRIPTIONS			
Pin #	Pin Name	Description	Pin Status
1	DVDD_IO	Digital Power for I/O pads	Input
2	GND	Ground	Input
3	N/C	No Connection or Connect to Ground	Input
4	IADDR0	I ² C Address Bit 0	Input
5	GND	Ground (optional)	Input
6	AVDD	Analog Power	Input
7	CS	SPI Enable (0), I ² C Enable (1)	Input
8	INT1/ DRDY	Interrupt 1/ Data Ready	Output
9	INT2	Interrupt 2	Output
10	N/C	Rev 1: No Connection or Ground	Input
11	Reserved	Ground	Input
12	SDO	SPI Serial Data Output	Output
13	SD(A/I/O)	I ² C Serial Data (SDA), SPI Serial Data Input (SDI), 3-wire interface Serial Data Output (SDO)	Open Drain/Input/ Output
14	SCL/SPC	I ² C Serial Clock (SCL), SPI Serial Clock (SPC)	Input

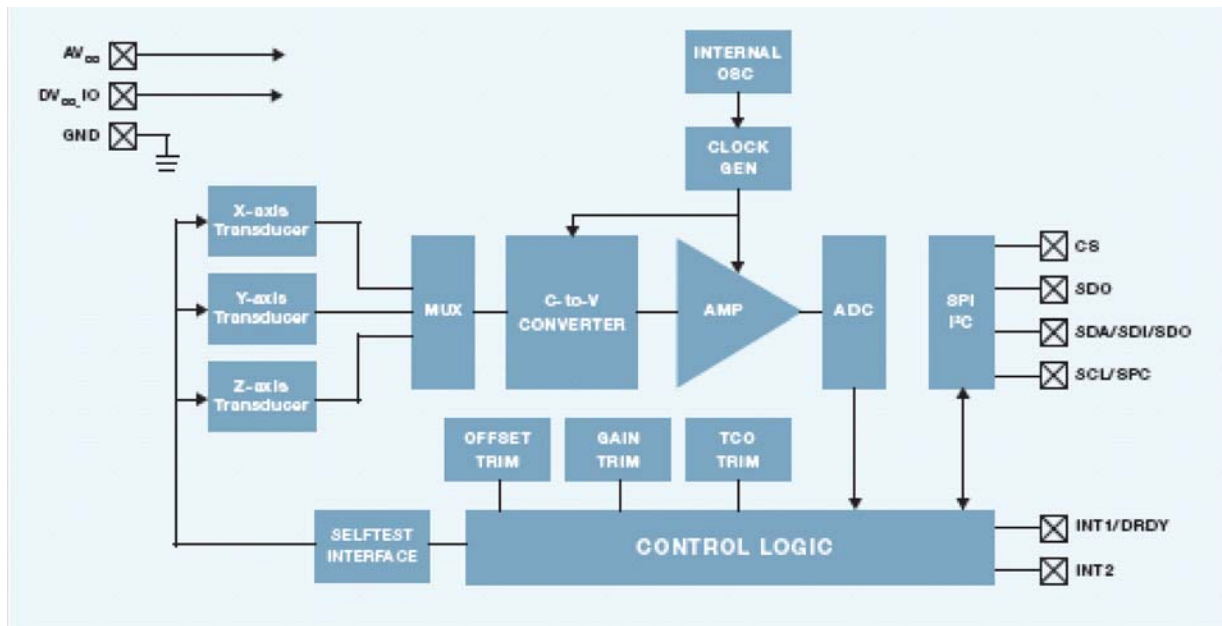

Figure 2. Simplified Accelerometer Functional Block Diagram

Table 1. Maximum Ratings

(Maximum ratings are the limits to which the device can be exposed without causing permanent damage.)

Rating	Symbol	Value	Unit
Maximum Acceleration (all axes)	g_{max}	5,000	g
Analog Supply Voltage	V_{DD}	-0.3 to +3.6	V
Digital I/O pins Supply Voltage	DV_{DD_IO}	-0.3 to +3.6	V
Drop Test	D_{drop}	1.8	m
Storage Temperature Range	T_{stg}	-40 to +125	°C

ELECTRO STATIC DISCHARGE (ESD)

WARNING: This device is sensitive to electrostatic discharge.

Although the Freescale accelerometer contains internal 2000V ESD protection circuitry, extra precaution must be taken by the user to protect the chip from ESD. A charge of over 2000 volts can accumulate on the human body or associated test equipment. A charge of this magnitude can

alter the performance or cause failure of the chip. When handling the accelerometer, proper ESD precautions should be followed to avoid exposing the device to discharges which may be detrimental to its performance.

Table 2. Operating CharacteristicsUnless otherwise noted: $-40^{\circ}\text{C} \leq T_A \leq 85^{\circ}\text{C}$, $2.4\text{ V} \leq AV_{DD} \leq 3.6\text{ V}$, Acceleration = 0g, Loaded output

Characteristic	Symbol	Min	Typ	Max	Unit
Analog Supply Voltage					
Standby/Operation Mode	AV_{DD}	2.4	2.8	3.6	V
Enable Bus Mode	AV_{DD}		0		V
Digital I/O Pins Supply Voltage					
Standby/Operation Mode	DV_{DD_IO}	1.71	1.8	AV_{DD}	V
Enable Bus Mode	DV_{DD_IO}	1.71	1.8	3.6	V
Supply Current Drain (AV_{DD}/GND)					
Operation Mode	I_{DD}	—	400	490	μA
Pulse Detect Function Mode	I_{DD}	—	400	490	μA
Standby Mode (except data loading and I ² C/SPI communication period)	I_{DD}	—	2.5	10	μA
Operating Temperature Range	T_A	-40	25	85	$^{\circ}\text{C}$
Acceleration Range	gFS	—	± 2	—	g
X-Axis, Y-Axis, Z-Axis	gFS	—	± 4	—	g
	gFS	—	± 8	—	g
Output Signal ($T_A=25^{\circ}\text{C}$, $AV_{DD} = 2.8\text{ V}$) GLVL [1:0]					
Zero g					
±2g range (25°C) 8bit 0 1	V_{OFF}	107	128	149	count
±4g range (25°C) 8bit 1 0	V_{OFF}		—		count
±8g range (25°C) 8bit 0 0	V_{OFF}		—		count
±8g range (25°C) 10bit 0 0	V_{OFF}	491	512	533	count
Resolution ($T_A=25^{\circ}\text{C}$, $AV_{DD} = 2.8\text{ V}$)					
±2g range (25°C) 8bit		13.9	15.6	17.3	count/g
±4g range (25°C) 8bit		—	31.2	—	count/g
±8g range (25°C) 8bit		—	62.4	—	count/g
±8g range (25°C) 10bit		13.9	15.6	17.3	count/g
Sensitivity ($T_A=25^{\circ}\text{C}$, $AV_{DD} = 2.8\text{ V}$)					
±2g range (25°C) 8bit	ΔV_{OUT}	58	64	70	LSB/g
±4g range (25°C) 8bit	ΔV_{OUT}	—	32	—	LSB/g
±8g range (25°C) 8bit	ΔV_{OUT}	—	16	—	LSB/g
±8g range (25°C) 10bit	ΔV_{OUT}	58	64	70	LSB/g
Self Test Output Response					
Zout	ΔST_Z	+48	+64	+80	LSB
Input High Voltage	V_{IH}	$0.7 \times V_{DD}$	—	—	V
Input Low Voltage	V_{IL}	—	—	$0.35 \times V_{DD}$	V
Internal Clock Frequency	t_{CLK}	140	150	160	kHz
SPI Frequency					
$DV_{DD_IO} < 2.4\text{ V}$		—	4	—	MHz
$DV_{DD_IO} > 2.4\text{ V}$		—	8	—	MHz
Bandwidth for Data Measurement (User Selectable)					
DFBW 0		—	62.5	—	Hz
DFBW 1		—	125	—	Hz
Output Data Rate					
Output Data Rate is 125 Hz when 62.5 bandwidth is selected.		—	125	—	Hz
Output Data rate is 250 Hz when 125Hz bandwidth is selected.		—	250	—	Hz

Table 2. Operating Characteristics (Continued)Unless otherwise noted: $-40^{\circ}\text{C} \leq T_A \leq 85^{\circ}\text{C}$, $2.4\text{ V} \leq AV_{DD} \leq 3.6\text{ V}$, Acceleration = 0g, Loaded output

Characteristic	Symbol	Min	Typ	Max	Unit
Control Timing					
Wait Time for IIC/SPI ready after power on	t_{su}		1		ms
Turn On Response Time (Standby to Normal Mode)	t_{ru}			20	ms
Turn Off Response Time (Normal to Standby Mode)	t_{rd}			20	ms
Self Test Response Time	t_{st}				ms
Sensing Element Resonant Frequency					
XY	$f_{GCELLXY}$		6.0		kHz
Z	f_{GCELLZ}		3.4		kHz
Nonlinearity (2 g range)		-1	—	+1	%FS
Cross Axis Sensitivity		-5		+5	%

Table 3. Function Parameters for Detection $V_L \leq V_{DD} \leq V_H$; $T_L \leq T_A \leq T_H$ unless otherwise specified

Characteristic	Symbol	Min	Typ	Max	Unit
Level Detection					
Detection Threshold Range		0		FS	g
Pulse Detection					
Pulse detection range (Adjustable range)		0.5		127	ms
Time step for pulse detection			0.5		ms
Threshold range for pulses		0		FS	g
Detection levels for threshold (5)			127		Levels
Latency timer (Adjustable range)		1		150	ms
Time Window (Adjustable range)		1		250	ms
Measurement bandwidth for detecting interrupt			600		Hz
Time step for latency timer and time window			1		ms

Note: The response time is between 10% of full scale Vdd input voltage and 90% of the final operating output voltage.

PRINCIPLE OF OPERATION

The Freescale accelerometer is a surface-micromachined integrated-circuit accelerometer. The device consists of a surface micromachined capacitive sensing cell (g-cell) and a signal conditioning ASIC contained in a single package. The sensing element is sealed hermetically at the wafer level using a bulk micromachined cap wafer. The g-cell is a mechanical structure formed from semiconductor materials (polysilicon) using semiconductor processes (masking and etching). It can be modeled as a set of beams attached to a movable central mass that move between fixed beams. The movable beams can be deflected from their rest position by subjecting the system to an acceleration (Figure 3).

As the beams attached to the central mass move, the distance from them to the fixed beams on one side will increase by the same amount that the distance to the fixed beams on the other side decreases. The change in distance is a measure of acceleration. The g-cell beams form two back-to-back capacitors (Figure 3). As the center beam moves with acceleration, the distance between the beams changes and each capacitor's value will change, ($C = A\epsilon/D$). Where A is the area of the beam, ϵ is the dielectric constant, and D is the distance between the beams.

The ASIC uses switched capacitor techniques to measure the g-cell capacitors and extract the acceleration data from the difference between the two capacitors. The ASIC also signal conditions and filters (switched capacitor) the signal, providing a high level digital output voltage that is proportional to acceleration.

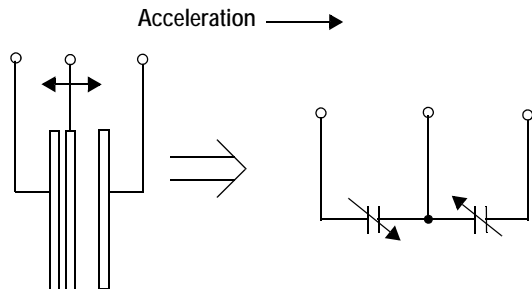

Figure 3. Simplified Transducer Physical Model

FEATURES

Self Test

The sensor provides a self test feature that allows the verification of the mechanical and electrical integrity of the accelerometer at any time before or after installation. This feature is critical in applications such as hard disk drive protection where system integrity must be ensured over the life of the product. Customers can use self test to verify the solderability to confirm that the part was mounted to the PCB correctly. When the self test function is initiated through the mode control register, accessing the “self test” bit, an electrostatic force is applied to each axis to cause it to deflect. The z-axis is trimmed to deflect 1g. This procedure assures that both the mechanical (g-cell) and electronic sections of the accelerometer are functioning.

g-Select

The g-Select feature enables the selection between 3 sensitivities for measurement. Depending on the values in the Mode control register (\$16), the MMA7455L's internal gain will be changed allowing it to function with a 2g, 4g or 8g measurement sensitivity. This feature is ideal when a product has applications requiring two or more sensitivities for optimum performance and for enabling multiple functions. The sensitivity can be changed during the operation by modifying the two GLVL bits located in the mode control register.

\$16: Mode control register (Read/Write)

D7	D6	D5	D4	D3	D2	D1	D0	Bit
--	DRPD	SPI3W	STON	GLVL[1]	GLVL[0]	MODE[1]	MODE[0]	Function
0	0	0	0	0	0	0	0	Default

Table 4. g-Select Description for 8-Bit Mode

GLVL [1:0]	g-Range	Sensitivity
00	8g	16 LSB/g
10	4g	32 LSB/g
01	2g	64 LSB/g

Standby Mode

This digital output 3-axis accelerometer provides a standby mode that is ideal for battery operated products. When standby mode is active, the device outputs are turned off, providing significant reduction of operating current. When the device is in standby mode the current will be reduced to 2.5 μ A typical. In standby mode the device can read and write to the registers with the I²C/SPI available, but no new measurements can be taken in this mode as all current consuming parts are off. The mode of the device is controlled through the mode control register by accessing the two mode bits as shown in Table 5.

Table 5. Mode Descriptions

MODE [0:1]	Function
00	Standby Mode
01	Measurement Mode
10	Level Detection Mode
11	Pulse Detection Mode

Measurement Mode

During measurement mode, continuous measurements on all three axes enabled. The g-range for 2g, 4g, or 8g are selectable with 8-bit data and the g-range of 8g is selectable with 10-bit data. The sample rate during measurement mode is 125 Hz with 62.5 BW filter selected. The sample rate is 250 Hz with the 125 Hz filter selected. Therefore, when a conversion is complete (signaled by the DRDY flag), the next measurement will be ready.

When measurements on all three axes are completed, a logic high level is output to the DRDY pin, indicating "Measurement data is ready." The DRDY status can be monitored by the DRDY bit in Status Register (Address: \$09). The DRDY pin is kept high until one of the three Output Value Registers are read. If the next measurement data is written before the previous data is read, the DOVR bit in the Status Register will be set. Also note that in measurement mode, level detection mode and pulse detection mode are not available.

LEVEL DETECTION MODE

Level Detection Mode

In level detection mode, the measurements for x, y and z are all enabled with 2g/4g and 8g range available. The detection of thresholds for an acceleration signal level for the combinations of one, two or all three axes can be enabled. This is typically used for motion detection where the threshold can be user set depending on the application or user specific requirements. When a motion event is detected, one of the interrupt pins (INT1 or INT2) will output a logic high output signaling the event is detected.

Setting for Motion Detection

To configure the MMA7455L for motion detection, after all three axes are enabled for detection, set the LDPL bit in Control Register 2 (Address: \$19) to 0. When the output value of one of the enabled axes exceeds the threshold limit value, either INT1 or INT2 pin will output a logic High indicating the event was detected.

- If LDPL = 0 and all three axes are enabled for detection
- When the specified motion condition is detected, INT1 or INT2 will output a Logic high
- "XOUT \geq Threshold" or "YOUT \geq Threshold" or "ZOUT \geq Threshold"

Threshold limit value is common for all three axes. Positive/negative and absolute value option is available

\$19	CTL2	—	—	—	—	—	DRVO	PDPL	LDPL
------	------	---	---	---	---	---	------	------	------



Setting for Freefall Detection

LDPL bit in Control Register 2 (Address: \$19) should be "1" for freefall detection. When the output values of all enabled axes are below the threshold limit value, logic high level is output to INT1 or INT2 pin and indicates the event was detected.

- If LDPL = 1 and all three axes are enabled for detection
- When the condition below was detected, Logic high level output to INT1 or INT2
- "XOUT \leq Threshold" and "YOUT \leq Threshold" and "ZOUT \leq Threshold"
- Threshold limit value is common for all three axes. Positive/negative and absolute value option is available.
- INT1/INT2 pin assignment for level detection is controlled by Control Register 1 (Address: \$18). Detection status is also able to be monitored by Detection source Register (Address: \$0A). Once the event was detected, INT pin or register bit will not be cleared until clear bit in Interrupt Latch Reset Register (Address: \$17) is set.

For a more detailed description of the Threshold Detect please refer to application note AN3571, "Threshold and Pulse Detect Using the MMA745xL".

Assigning and Clearing the Interrupt Pins

INT1/INT2 pin assignment for level detection is controlled by Control Register 1 (Address:\$18).

\$18	CTL1	—	THOPT	ZDA	YDA	XDA	INTRG[1]	INTRG[0]	INTPIN
------	------	---	-------	-----	-----	-----	----------	----------	--------

INTPIN:

- 0:INT1 will be used for event
- 1:INT2 will be used for event



Detection status is able to be monitored by Detection Source Register (Address:\$0A). Once the configured event is detected, INT pin or register bit will not be cleared until the respective clear bit (CLRINT1 or CLRINT2) in Interrupt Latch Reset Register (Address: \$17) is set. **CLRINT1 and CLRINT2 should be cleared before starting next detection. Otherwise, INT pin or register will not set.**

\$17	INTRS	—	—	—	—	—	—]	CLRINT2	CLRINT1
------	-------	---	---	---	---	---	----	---------	---------



NOTE: Measurement period and bandwidth for level detection is different from data output rate and the bandwidth of “measurement.” Please refer to Functional Parameter for Detection for more information.

PULSE DETECTION MODE

Pulse Detection Mode

In pulse detection mode, only 8g range is available. It is independent from measurement g-range. Therefore if the measurement range is in the 2g or 4g mode, the pulse detection range will still be 8g. Measurements for x, y and z in 2g/4g or 8g mode are enabled. The level detection is also enabled in this mode. The pulse detected by the acceleration signal is enabled with single pulse and double pulse detection allowing the choice of either positive, negative or absolute value pulse detection.

Setting for Motion Detection

For the PDPL bit in Control Register 2 (Address: \$19) the register should be set to “0” for motion detection. When the output value of one of the enabled axes exceeds the threshold limit value, logic high level is output to INT1 or INT2 pin and indicates the event was detected.

- If PDPL = 0 and all three axes are enabled for detection
- When the condition below was detected, logic high level outputs to INT1 or INT2
- “XOUT ≥Threshold” or “YOUT ≥Threshold” or “ZOUT ≥Threshold”

Setting for Freefall Detection

To configure the MMA7455L for freefall detection, set the PDPL bit in Control Register 2 (Address: \$19) to 1 and Time Window for 2nd pulse value should be “0” for freefall detection. When the output values of all enabled axes are below the threshold limit continuously during the period specified in Latency Timer Value register, logic high level is output to INT1 or INT2 pin and indicates the event was detected.

- If PDPL = 1, TW[7:0] = 0 and all three axes are enabled for detection
- When the condition below was detected, Logic high level output to INT1 or INT2
- “XOUT ≤Threshold” and “YOUT ≤Threshold” and “ZOUT ≤Threshold”
- INT1/INT2 pin assignment for pulse detection is controlled by Control Register 1 (Address: \$18). Detection status is also able to be monitored by Interrupt Source Register. Once the event was detected, INT pin or register bit will not be cleared until clear bit in Interrupt Latch Reset Register (Address: \$17) is set.

\$19	CTL2	—	—	—	—	—	DRVO	PDPL	LDPL
------	------	---	---	---	---	---	------	------	------



\$1E	TW	TW[7]	TW[6]	TW[5]	TW[4]	TW[3]	TW[2]	TW[1]	TW[0]
------	----	-------	-------	-------	-------	-------	-------	-------	-------

When the output values of all enabled axes are below the threshold limit continuously during the period specified in Latency Timer Value Register, logic high level is output to INT1 or INT2 pin indicating freefall was detected.

For a more detailed description of the Threshold Detect please refer to application note AN3571, “Threshold and Pulse Detect Using the MMA745xL”.

MMA7455L

PULSE DETECTION

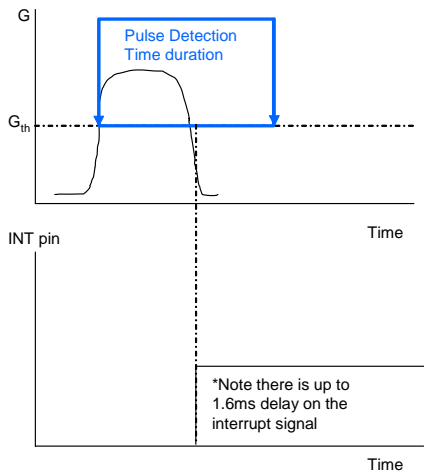

Single Pulse Detection (\$19 PDPL=0 indicating motion detection)
Time Window for 2nd pulse \$1E TW=0 indicating single pulse

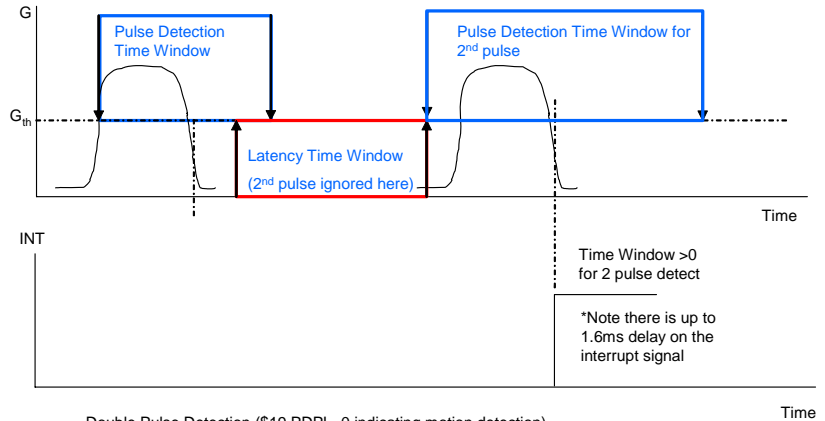

Double Pulse Detection (\$19 PDPL=0 indicating motion detection)
Time Window for 2nd pulse \$1E TW>0 indicating double pulse

Figure 4. Single Pulse Detection

Figure 5. Double Pulse Detection

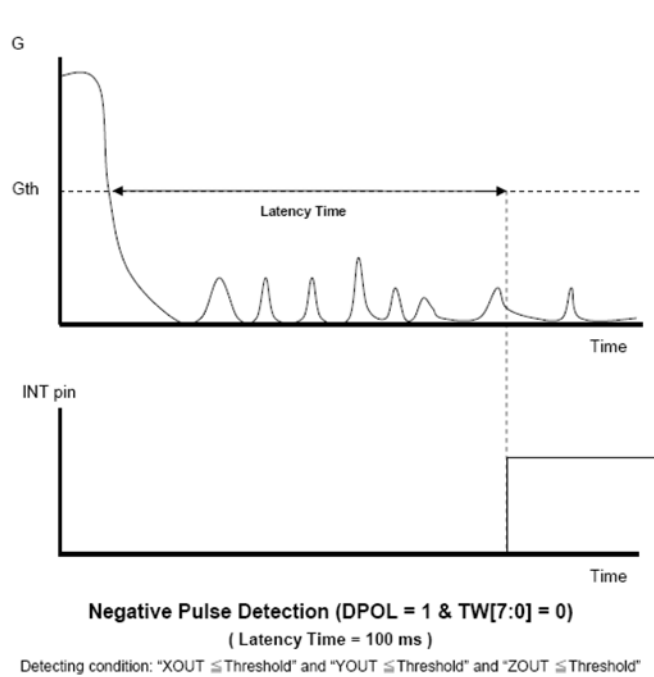

Figure 6. Negative Pulse Detection

DIGITAL INTERFACE

The MMA7455L has both an I²C and SPI digital output available for a communication interface. When CS pin is used for Slave Select, SPI communication is selected. When CS is high, I²C communication is selected and SPI is disabled.

NOTE: It is recommended to disable I²C during SPI communication to avoid communication errors between devices using a different SPI communication protocol. To disable I²C, set the I2CDIS bit in I²C Device Address register using SPI.

I²C SLAVE INTERFACE

I²C is a synchronous serial communication between a master device and one or more slave devices. The master is typically a microcontroller, which provides the serial clock signal and addresses the slave device(s) on the bus. The MMA7455L communicates only in slave operation where the device address is \$1D. Multiple read and write modes are available. The protocol supports slave only operation. It does not support Hs mode, "10-bit addressing", "general call" and "START byte".

SINGLE BYTE READ

The MMA7455L has an 8-bit ADC that can sample, convert and return sensor data on request. The transmission of an 8-bit command begins on the falling edge of SCL. After the eight clock cycles are used to send the command, note that the data returned is sent with the MSB first once the data is received. Figure 7 shows the timing diagram for the accelerometer 8-bit I²C read operation. The Master (or MCU) transmits a start condition (ST) to the MMA7455L, slave address (\$1D), with the R/W bit set to "0" for a write, and the

MMA7455L sends an acknowledgement. Then the Master (or MCU) transmits the 8-bit address of the register to read and the MMA7455L sends an acknowledgement. The Master (or MCU) transmits a repeated start condition (SR) and then addresses the MMA7455L (\$1D) with the R/W bit set to "1" for a read from the previously selected register. The Slave then acknowledges and transmits the data from the requested register. The Master does not acknowledge (NACK) it received the transmitted data, but transmits a stop condition to end the data transfer.

MULTIPLE BYTES READ

The MMA7455L automatically increments the received register address commands after a read command is received. Therefore, after following the steps of a single byte read, multiple bytes of data can be read from sequential registers after each MMA7455L acknowledgment (ACK) is received until a NACK is received from the Master followed by a stop condition (SP) signalling an end of transmission. See Figure 8.

SINGLE BYTE WRITE

To start a write command, the Master transmits a start condition (ST) to the MMA7455L, slave address (\$1D) with the R/W bit set to "0" for a write, the MMA7455L sends an acknowledgement. Then the Master (MCU) transmits the 8-bit address of the register to write to, and the MMA7455L sends an acknowledgement. Then the Master (or MCU) transmits the 8-bit data to write to the designated register and the MMA7455L sends an acknowledgement that it has received the data. Since this transmission is complete, the Master transmits a stop condition (SP) to the data transfer. The data sent to the MMA7455L is now stored in the appropriate register. See Figure 9.

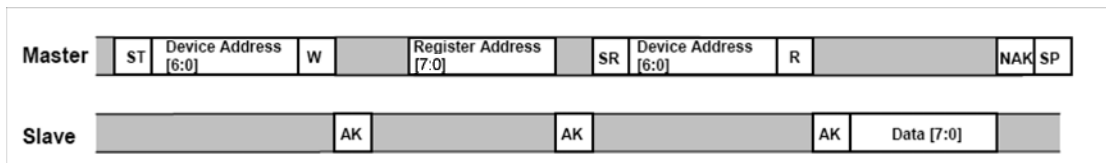

Figure 7. Single Byte Read - The Master is reading one address from the MMA7455L

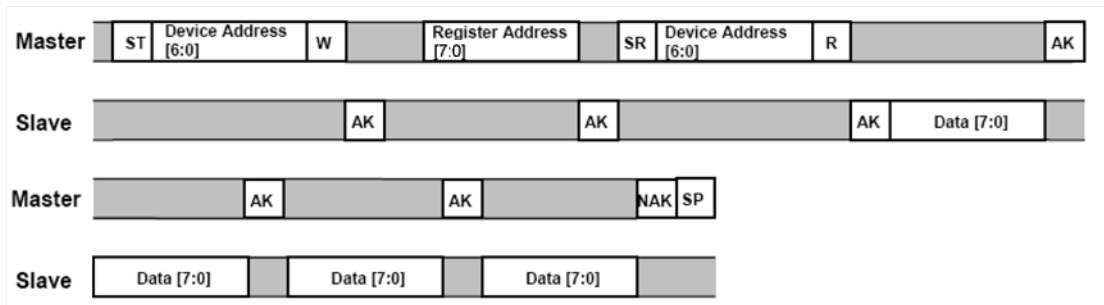

Figure 8. Multiple Bytes Read - The Master is reading multiple sequential registers from the MMA7455L

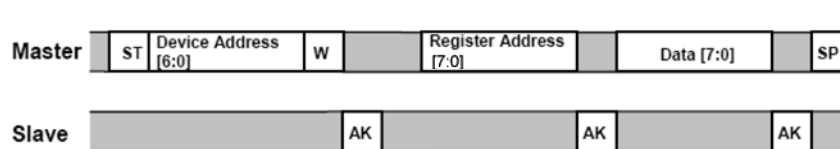

Figure 9. Single Byte Write - The Master (MCU) is writing to a single register of the MMA7455L

MULTIPLE BYTES WRITE

The MMA7455L automatically increments the received register address commands after a write command is received. Therefore, after following the steps of a single byte

write, multiple bytes of data can be written to sequential registers after each MMA7455L acknowledgment (ACK) is received. See [Figure 10](#).

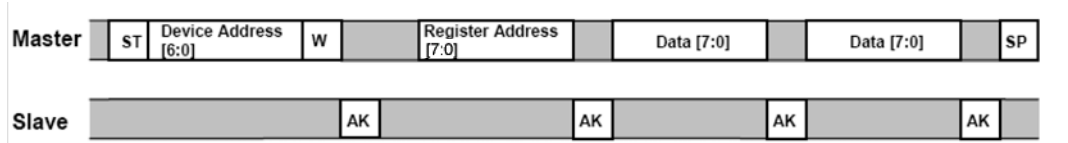

Figure 10. Multiple Byte Writes - The Master (MCU) is writing to multiple sequential registers of the MMA7455L

SPI SLAVE INTERFACE

The MMA7455L also uses serial peripheral interface communication as a digital communication. The SPI communication is primarily used for synchronous serial communication between a master device and one or more slave devices. See [Figure 16](#) for an example of how to configure one master with two MMA7455L devices. The MMA7455L is always operated as a slave device. Typically, the master device would be a microcontroller which would drive the clock (SPC) and chip select (CS) signals.

The SPI interface consists of two control lines and two data lines: CS, SPC, SDI, and SDO. The CS, also known as Chip Select, is the slave device enable which is controlled by the SPI master. CS is driven low at the start of a transmission. CS is then driven high at the end of a transmission. SPC is the Serial Port Clock which is also controlled by the SPI master. SDI and SDO are the Serial Port Data Input and the Serial Port Data Output. The SDI and SDO data lines are driven at the falling edge of the SPC and should be captured at the rising edge of the SPC.

Read and write register commands are completed in 16 clock pulses or in multiples of 8, in the case of a multiple byte read/write.

SPI READ OPERATION

A SPI read transfer consists of a 1-bit Read/Write signal, a 6-bit address, and 1-bit don't care bit. (1-bit R/W=0 + 6-bits address + 1-bit don't care). The data to read is sent by the SPI interface during the next transfer. See [Figure 11](#) and [Figure 12](#) for the timing diagram for an 8-bit read in 4 wire and 3 wire modes, respectively.

SPI WRITE OPERATION

In order to write to one of the 8-bit registers, an 8-bit write command must be sent to the MMA7455L. The write command consists of an MSB (0=read, 1=write) to indicate writing to the MMA7455L register, followed by a 6-bit address and 1 don't care bit.

The command should then be followed the 8-bit data transfer. See [Figure 13](#) for the timing diagram for an 8-bit data write.

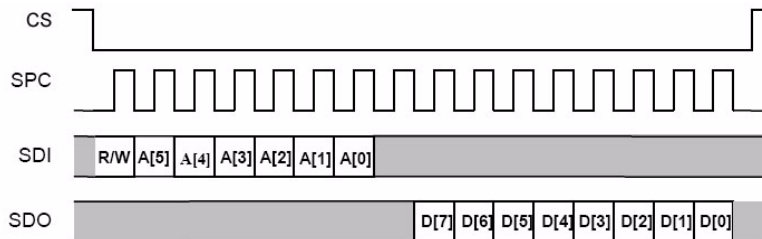

Figure 11. SPI Timing Diagram for 8-Bit Register Read (4 Wire Mode)

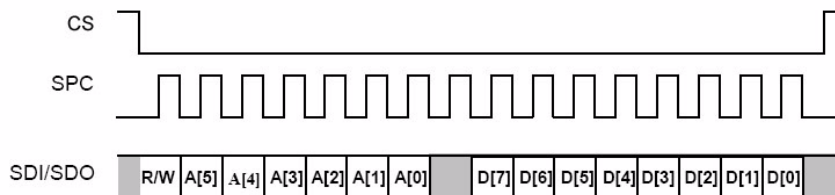

Figure 12. SPI Timing Diagram for 8-Bit Register Read (3 Wire Mode)

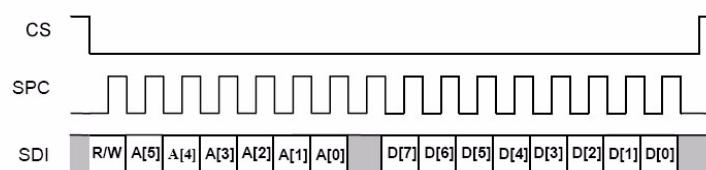

Figure 13. SPI Timing Diagram for 8-Bit Register Write (3 Wire Mode)

BASIC CONNECTIONS

Pin Descriptions

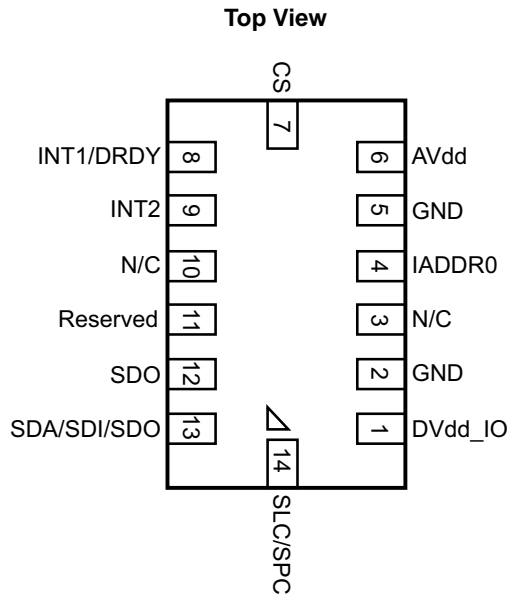

Figure 14. Pinout Description

PIN DESCRIPTIONS			
1	DVDD_IO	Digital Power for I/O pads	Input
2	GND	Ground	Input
3	N/C	No Connection or Connect to Ground	Input
4	IADDR0	I ² C Address Bit 0	Input
5	GND	Ground (optional)	Input
6	AVDD	Analog Power	Input
7	CS	SPI Enable (0), I ² C Enable (1)	Input
8	INT1/DRDY	Interrupt 1/ Data Ready	Output
9	INT2	Interrupt 2	Output
10	N/C	Rev 1: No Connection or Ground	Input
11	Reserved	Ground	Input
12	SDO	SPI Serial Data Output	Output
13	SD(A/I/O)	I ² C Serial Data (SDA), SPI Serial Data Input (SDI), 3-wire interface Serial Data Output (SDO)	Open Drain/ Input/ Output
14	SCL/SPC	I ² C Serial Clock (SCL), SPI Serial Clock (SPC)	Input

Recommended PCB Layout for Interfacing Accelerometer to Microcontroller

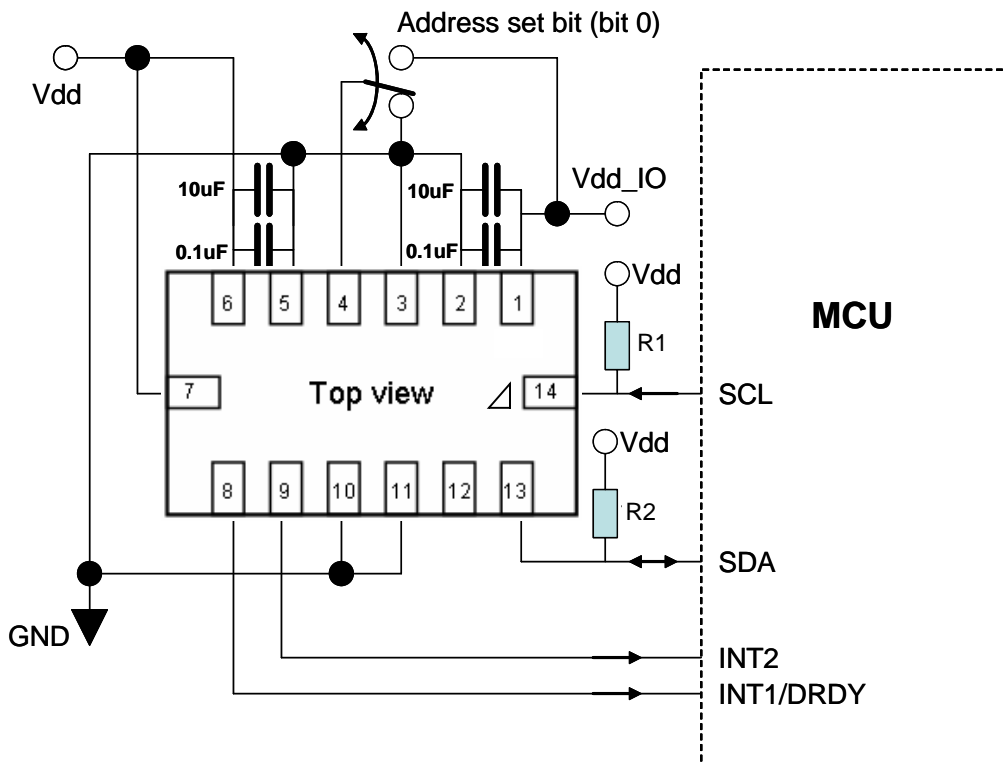

Figure 15. I²C Connection to MCU

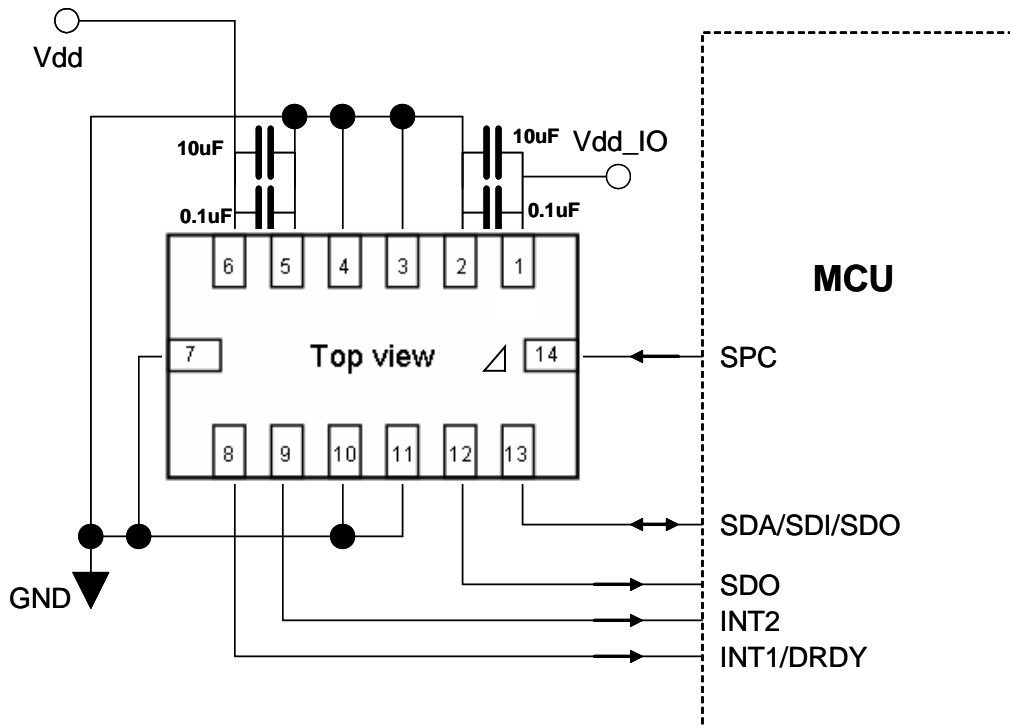

Figure 16. SPI Connection to MCU

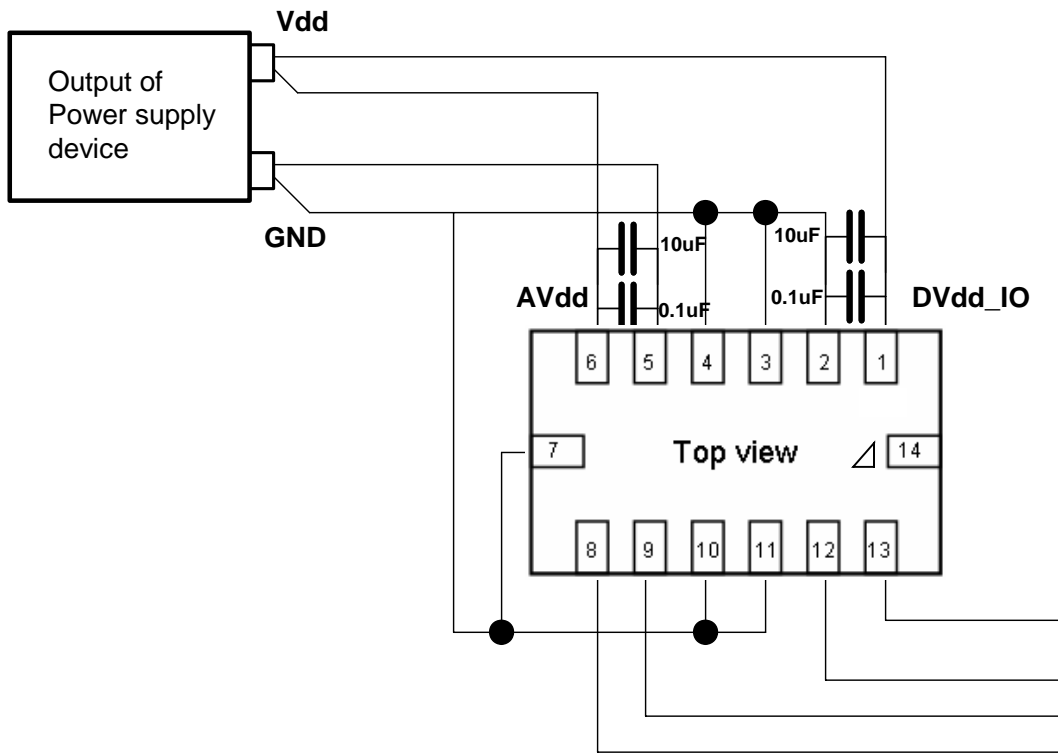

Figure 17. In case of same supply between AVdd(6) and DVdd_IO(1)

NOTES:

1. Use a 1 μ F and a 10 μ F capacitor on AV_{DD} to and DV_{DD_IO} to decouple the power source.
2. Physical coupling distance of the accelerometer to the microcontroller should be minimal.
3. Place a ground plane beneath the accelerometer to reduce noise, the ground plane should be attached to all of the open ended terminals shown in [Figure 15](#) and [Figure 16](#).
4. PCB layout of power and ground should not couple power supply noise.
5. Accelerometer and microcontroller should not be a high current path.
6. Any external power supply switching frequency should be selected such that they do not interfere with the internal accelerometer sampling frequency (sampling frequency). This will prevent aliasing errors.

Table 6. User Register Summary

Address	Name	Definition	Bit 7	Bit 6	Bit 5	Bit 4	Bit 3	Bit 2	Bit 1	Bit 0
\$00	XOUTL	10 bits output value X LSB	XOUT[7]	XOUT[6]	XOUT[5]	XOUT[4]	XOUT[3]	XOUT[2]	XOUT[1]	XOUT[0]
\$01	XOUTH	10 bits output value X MSB	--	--	--	--	--	--	XOUT[9]	XOUT[8]
\$02	YOUTL	10 bits output value Y LSB	YOUT[7]	YOUT[6]	YOUT[5]	YOUT[4]	YOUT[3]	YOUT[2]	YOUT[1]	YOUT[0]
\$03	YOUTH	10 bits output value Y MSB	--	--	--	--	--	--	YOUT[9]	YOUT[8]
\$04	ZOUTL	10 bits output value Z LSB	ZOUT[7]	ZOUT[6]	ZOUT[5]	ZOUT[4]	ZOUT[3]	ZOUT[2]	ZOUT[1]	ZOUT[0]
\$05	ZOUTH	10 bits output value Z MSB	--	--	--	--	--	--	ZOUT[9]	ZOUT[8]
\$06	XOUT8	8 bits output value X	XOUT[7]	XOUT[6]	XOUT[5]	XOUT[4]	XOUT[3]	XOUT[2]	XOUT[1]	XOUT[0]
\$07	YOUT8	8 bits output value Y	YOUT[7]	YOUT[6]	YOUT[5]	YOUT[4]	YOUT[3]	YOUT[2]	YOUT[1]	YOUT[0]
\$08	ZOUT8	8 bits output value Z	ZOUT[7]	ZOUT[6]	ZOUT[5]	ZOUT[4]	ZOUT[3]	ZOUT[2]	ZOUT[1]	ZOUT[0]
\$09	STATUS	Status registers	--	--	--	--	--	PERR	DOVR	DRDY
\$0A	DETSRC	Detection source registers	LDX	LDY	LDZ	PDX	PDY	PDZ	INT1	INT2
\$0B	TOUT	"Temperature output value" (Optional)	TMP[7]	TMP[6]	TMP[5]	TMP[4]	TMP[3]	TMP[2]	TMP[1]	TMP[0]
\$0C		(Reserved)	--	--	--	--	--	--	--	--
\$0D	I2CAD	I ² C device address	I2CDIS	DAD[6]	DAD[5]	DAD[4]	DAD[3]	DAD[2]	DAD[1]	DAD[0]
\$0E	USRINF	User information (Optional)	UI[7]	UI[6]	UI[5]	UI[4]	UI[3]	UI[2]	UI[1]	UI[0]
\$0F	WHOAMI	"Who am I" value (Optional)	ID[7]	ID[6]	ID[5]	ID[4]	ID[3]	ID[2]	ID[1]	ID[0]
\$10	XOFFL	Offset drift X value (LSB)	XOFF[7]	XOFF[6]	XOFF[5]	XOFF[4]	XOFF[3]	XOFF[2]	XOFF[1]	XOFF[0]
\$11	XOFFH	Offset drift X value (MSB)	--	--	--	--	--	XOFF[10]	XOFF[9]	XOFF[8]
\$12	YOFFL	Offset drift Y value (LSB)	YOFF[7]	YOFF[6]	YOFF[5]	YOFF[4]	YOFF[3]	YOFF[2]	YOFF[1]	YOFF[0]
\$13	YOFFH	Offset drift Y value (MSB)	--	--	--	--	--	YOFF[10]	YOFF[9]	YOFF[8]
\$14	ZOFFL	Offset drift Z value (LSB)	ZOFF[7]	ZOFF[6]	ZOFF[5]	ZOFF[4]	ZOFF[3]	ZOFF[2]	ZOFF[1]	ZOFF[0]
\$15	ZOFFH	Offset drift Z value (MSB)	--	--	--	--	--	ZOFF[10]	ZOFF[9]	ZOFF[8]
\$16	MCTL	Mode control	LPEN	DRPD	SPI3W	STON	GLVL[1]	GLVL[0]	MOD[1]	MOD[0]
\$17	INTRST	Interrupt latch reset	--	--	--	--	--	--	CLRINT2	CLRINT1
\$18	CTL1	Control 1	--	THOPT	ZDA	YDA	XDA	INTRG[1]	INTRG[0]	INTPIN
\$19	CTL2	Control 2	--	--	--	--	--	DRVO	PDPL	LDPL
\$1A	LDTH	Level detection threshold limit value	LDTH[7]	LDTH[6]	LDTH[5]	LDTH[4]	LDTH[3]	LDTH[2]	LDTH[1]	LDTH[0]
\$1B	PDTH	Pulse detection threshold limit value	PDTH[7]	PDTH[6]	PDTH[5]	PDTH[4]	PDTH[3]	PDTH[2]	PDTH[1]	PDTH[0]
\$1C	PW	Pulse duration value	PD[7]	PD[6]	PD[5]	PD[4]	PD[3]	PD[2]	PD[1]	PD[0]
\$1D	LT	Latency time value	LT[7]	LT[6]	LT[5]	LT[4]	LT[3]	LT[2]	LT[1]	LT[0]
\$1E	TW	Time window for 2 nd pulse value	TW[7]	TW[6]	TW[5]	TW[4]	TW[3]	TW[2]	TW[1]	TW[0]
\$1F		(Reserved)	--	--	--	--	--	--	--	--

REGISTER DEFINITIONS

\$00: 10bits output value X LSB (Read only)

D7	D6	D5	D4	D3	D2	D1	D0	Bit
XOUT [7]	XOUT [6]	XOUT [5]	XOUT [4]	XOUT [3]	XOUT [2]	XOUT [1]	XOUT[0]	Function
0	0	0	0	0	0	0	0	Default

Signed byte data (2's compliment): Zero G = 10'h000

Reading low byte XOUTL latches high byte XOUTH to allow 10-bit reads.

XOUTH should be read directly following XOUTL read.

\$01: 10bits output value X MSB (Read only)

D7	D6	D5	D4	D3	D2	D1	D0	Bit
--	--	--	--	--	--	XOUT [9]	XOUT[8]	Function
0	0	0	0	0	0	0	0	Default

Signed byte data (2's compliment): Zero G = 10'h000

Reading low byte XOUTL latches high byte XOUTH to allow 10-bit reads.

XOUTH should be read directly following XOUTL read.

\$02: 10bits output value Y LSB (Read only)

D7	D6	D5	D4	D3	D2	D1	D0	Bit
YOUT [7]	YOUT [6]	YOUT [5]	YOUT [4]	YOUT [3]	YOUT [2]	YOUT [1]	YOUT[0]	Function
0	0	0	0	0	0	0	0	Default

Signed byte data (2's compliment): Zero G = 10'h000

Reading low byte YOUTL latches high byte YOUTH to allow coherent 10-bit reads.

YOUTH should be read directly following YOUTL.

\$03: 10bits output value Y MSB (Read only)

D7	D6	D5	D4	D3	D2	D1	D0	Bit
--	--	--	--	--	--	YOUT [9]	YOUT[8]	Function
0	0	0	0	0	0	0	0	Default

Signed byte data (2's compliment): Zero G = 10'h000

Reading low byte ZOUTL latches high byte ZOUTH to allow coherent 10-bit reads.

ZOUTH should be read directly following ZOUTL.

\$04: 10bits output value Z LSB (Read only)

D7	D6	D5	D4	D3	D2	D1	D0	Bit
ZOUT [7]	ZOUT [6]	ZOUT [5]	ZOUT [4]	ZOUT [3]	ZOUT [2]	ZOUT [1]	ZOUT[0]	Function
0	0	0	0	0	0	0	0	Default

Signed byte data (2's compliment): Zero G = 10'h000

Reading low byte ZOUTL latches high byte ZOUTH to allow coherent 10-bit reads.

ZOUTH should be read directly following ZOUTL.

\$05: 10bits output value X MSB (Read only)

D7	D6	D5	D4	D3	D2	D1	D0	Bit
--	--	--	--	--	--	ZOUT [9]	ZOUT[8]	Function
0	0	0	0	0	0	0	0	Default

\$06: 8bits output value X (Read only)

D7	D6	D5	D4	D3	D2	D1	D0	Bit
XOUT[7]	XOUT [6]	XOUT [5]	XOUT [4]	XOUT [3]	XOUT [2]	XOUT [1]	XOUT [0]	Function
0	0	0	0	0	0	0	0	Default

Signed byte data (2's compliment): Zero G = 8'h00

\$07: 8bits output value Y (Read only)

D7	D6	D5	D4	D3	D2	D1	D0	Bit
YOUT[7]	YOUT [6]	YOUT [5]	YOUT [4]	YOUT [3]	YOUT [2]	YOUT [1]	YOUT [0]	Function
0	0	0	0	0	0	0	0	Default

Signed byte data (2's compliment): Zero G = 8'h00

\$08: 8bits output value Z (Read only)

D7	D6	D5	D4	D3	D2	D1	D0	Bit
ZOUT[7]	ZOUT [6]	ZOUT [5]	ZOUT [4]	ZOUT [3]	ZOUT [2]	ZOUT [1]	ZOUT [0]	Function
0	0	0	0	0	0	0	0	Default

Signed byte data (2's compliment): Zero G = 8'h00

\$09: Status register (Read only)

D7	D6	D5	D4	D3	D2	D1	D0	Bit
--	--	--	--	--	PERR	DOVR	DRDY	Function
0	0	0	0	0	0	0	0	Default

DRDY

1: Data is ready
 0: Data is not ready

DOVR

1: Data is over written
 0: Data is not over written

PERR

1: Parity error is detected in trim data. Then, self test is disabled
 0: Parity error is not detected in trim data

\$0A: Detection source register (Read only)

D7	D6	D5	D4	D3	D2	D1	D0	Bit
LDX	LDY	LDZ	PDX	PDY	PDZ	INT2	INT1	Function
0	0	0	0	0	0	0	0	Default

LDX

1: Level detection detected on X axis
 0: Level detection not detected on X axis

LDY

1: Level detection detected on Y axis
 0: Level detection not detected on Y axis

LDZ

1: Level detection detected on Z axis
 0: Level detection not detected on Z axis

PDX *Note

1: Pulse is detected on X axis at single pulse detection
 0: Pulse is not detected on X axis at single pulse detection

PDY *Note

1: Pulse is detected on Y axis at single pulse detection
 0: Pulse is not detected on Y axis at single pulse detection

PDZ *Note

1: Pulse is detected on Z axis at single pulse detection
 0: Pulse is not detected on Z axis at single pulse detection

Note: This bit value is not valid at double pulse detection**INT1**

1: Interrupt assigned by "Detection control" register is detected

0: Interrupt assigned by "Detection control" register is not detected

INT2

1: Interrupt assigned by "Detection control" register is detected

0: Interrupt assigned by "Detection control" register is not detected

Note:** Must define DRDY to be an output to either INT1 or not.**Note: Bit weight is for 2g 8 bit data output. Typical value for reference only. Variation is specified in "Electrical Characteristics" section.*\$0D: I²C Device Address (Bit 6-0: Read only, Bit 7: Read/Write)**

D7	D6	D5	D4	D3	D2	D1	D0	Bit
I2CDIS	DVAD[6]	DVAD[5]	DVAD[4]	DVAD[3]	DVAD[2]	DVAD[1]	DVAD[0]	Function
0	0	0	1	1	1	0	1	Default

I2CDIS

0: I²C and SPI are available.

1: I²C is disabled.

DVAD[6:0]: I²C device address

\$0E: User Information (Read Only: Optional)

D7	D6	D5	D4	D3	D2	D1	D0	Bit
UI[7]	UI[6]	UI[5]	UI[4]	UI[3]	UI[2]	UI[1]	UI[0]	Function
0/OTP	0/OTP	0/OTP	0/OTP	0/OTP	0/OTP	0/OTP	0/OTP	Default

UI2[7:0]: User information

\$0F: “Who Am I” value (Read only: Optional)

D7	D6	D5	D4	D3	D2	D1	D0	Bit
ID[7]	ID [6]	ID [5]	ID [4]	ID [3]	ID [2]	ID [1]	ID [0]	Function
0/OTP	0/OTP	0/OTP	0/OTP	0/OTP	0/OTP	0/OTP	0/OTP	Default

\$10: Offset drift X LSB (Read/Write)

D7	D6	D5	D4	D3	D2	D1	D0	Bit
XOFF[7]	XOFF [6]	XOFF [5]	XOFF [4]	XOFF [3]	XOFF [2]	XOFF [1]	XOFF [0]	Function
0	0	0	0	0	0	0	0	Default

Signed byte data (2's compliment): User level offset trim value for X axis

Bit	XOFF[7]	XOFF[6]	XOFF[5]	XOFF[4]	XOFF[3]	XOFF[2]	XOFF[1]	XOFF[0]
Weight (*Note)	64 LSB	32 LSB	16 LSB	8 LSB	4 LSB	2 LSB	1 LSB	0.5 LSB

***Note:** Bit weight is for 2g 8bit data output. Typical value for reference only. Variation is specified in “Electrical Characteristics” section.

\$11: Offset drift X MSB (Read/Write)

D7	D6	D5	D4	D3	D2	D1	D0	Bit
--	--	--	--	--	XOFF [10]	XOFF [9]	XOFF [8]	Function
0	0	0	0	0	0	0	0	Default

Signed byte data (2's compliment): User level offset trim value for X axis

\$12: Offset drift Y LSB (Read/Write)

D7	D6	D5	D4	D3	D2	D1	D0	Bit
YOFF[7]	YOFF [6]	YOFF [5]	YOFF [4]	YOFF [3]	YOFF [2]	YOFF [1]	YOFF [0]	Function
0	0	0	0	0	0	0	0	Default

Signed byte data (2's compliment): User level offset trim value for Y axis

Bit	YOFF[7]	YOFF[6]	YOFF[5]	YOFF[4]	YOFF[3]	YOFF[2]	YOFF[1]	YOFF[0]
Weight (*Note)	64 LSB	32 LSB	16 LSB	8 LSB	4 LSB	2 LSB	1 LSB	0.5 LSB

***Note:** Bit weight is for 2g 8bit data output. Typical value for reference only. Variation is specified in “Electrical Characteristics” section.

\$13: Offset drift Y MSB (Read/Write)

D7	D6	D5	D4	D3	D2	D1	D0	Bit
--	--	--	--	--	YOFF [10]	YOFF [9]	YOFF [8]	Function
0	0	0	0	0	0	0	0	Default

Signed byte data (2's compliment): User level offset trim value for Y axis

Bit	YOFF[10]	YOFF[9]	YOFF[8]
Weight (*Note)	Polarity	256 LSB	128 LSB

***Note:** Bit weight is for 2g 8bit data output. Typical value for reference only. Variation is specified in “Electrical Characteristics” section.

\$14: Offset drift Z LSB (Read/Write)

D7	D6	D5	D4	D3	D2	D1	D0	Bit
ZOFF[7]	ZOFF[6]	ZOFF[5]	ZOFF[4]	ZOFF[3]	ZOFF[2]	ZOFF[1]	ZOFF[0]	Function
0	0	0	0	0	0	0	0	Default

Signed byte data (2's complement): User level offset trim value for Z axis

Bit	ZOFF[7]	ZOFF[6]	ZOFF[5]	ZOFF[4]	ZOFF[3]	ZOFF[2]	ZOFF[1]	ZOFF[0]
Weight (*Note)	64 LSB	32 LSB	16 LSB	8 LSB	4 LSB	2 LSB	1 LSB	0.5 LSB

***Note:** Bit weight is for 2g 8bit data output. Typical value for reference only. Variation is specified in "Electrical Characteristics" section.

\$15: Offset drift Z MSB (Read/Write)

D7	D6	D5	D4	D3	D2	D1	D0	Bit
--	--	--	--	--	ZOFF[10]	ZOFF[9]	ZOFF[8]	Function
0	0	0	0	0	0	0	0	Default

Signed byte data (2's complement): User level offset trim value for Z axis

Bit	ZOFF[10]	ZOFF[9]	ZOFF[8]
Weight (*Note)	Polarity	256 LSB	128 LSB

***Note:** Bit weight is for 2g 8bit data output. Typical value for reference only. Variation is specified in "Electrical Characteristics" section.

\$16: Mode control register (Read/Write)

D7	D6	D5	D4	D3	D2	D1	D0	Bit
--	DRPD	SPI3W	STON	GLVL[1]	GLVL[0]	MODE[1]	MODE[0]	Function
0	0	0	0	0	0	0	0	Default

MODE[1:0]	Function
00	Standby Mode
01	Measurement Mode
10	Level Detection Mode
11	Pulse Detection Mode

GLVL [1:0]

00: 8g is selected for measurement range.

10: 4g is selected for measurement range.

01: 2g is selected for measurement range.

STON

0: Self test is not enabled

1: Self test is enabled

SPI3W

0: SPI is 4 wire mode

1: SPI is 3 wire mode

DRPD

0: Data ready status is output to INT1/DRDY PIN

1: Data ready status is not output to INT1/DRDY PIN

\$17: Interrupt latch reset (Read/Write)

D7	D6	D5	D4	D3	D2	D1	D0	Bit
--	--	--	--	--	--	CLR_INT2	CLR_INT1	Function
0	0	0	0	0	0	0	0	Default

CLR_INT1

1: Clear "INT1" and LDX/LDY/LDZ or PDX/PDY/PDZ bits in "Detection source" register depending on "Detection control" register setting.

0: Do not clear "INT1" LDX/LDY/LDZ or PDX/PDY/PDZ bits in "Detection source" register.

CLR_INT2

1: Clear "INT2" and LDX/LDY/LDZ or PDX/PDY/PDZ bits in "Detection source" register depending on "Detection control" register setting.

0: Do not clear "INT2" and LDX/LDY/LDZ or PDX/PDY/PDZ bits in "Detection source" register.

EXAMPLE: How to clear both interrupt flags

This example is to show how to reset the interrupt flags

```
void ClearIntLatch(void)
{
    IIC_ByteWrite(INTRST, 0x03);
    IIC_ByteWrite(INTRST, 0x00);
}
```

To clear the interrupts you must first write a logic 1 into both registers and then a logic 0.

\$18: Control 1 (Read/Write)

D7	D6	D5	D4	D3	D2	D1	D0	Bit
DFBW	THOPT	ZDA	YDA	XDA	INTREG[1]	INTREG[0]	INTPIN	Function
0	0	0	0	0	0	0	0	Default

INTPIN

0: INT1 pin is routed to "INT1" register and INT2 pin is routed to "INT2" register.

1: INT2 pin is routed to "INT1" register and INT1 pin is routed to "INT2" register.

INTREG[1:0]	"INT1" register bit	"INT2" register bit
00	Level Detection	Pulse Detection
01	Pulse Detection	Level Detection
10	Single pulse detection (*Note)	Pulse Detection

Note: Assigned to single pulse detection even if double pulse detection is selected. "Double pulse detection selected" means "Time window for 2nd pulse" is not equal to zero. When double pulse detection is selected, INT1 register bit is not able to be cleared by setting CLR_INT1 bit. It's cleared by setting CLR_INT2 bit. In this case, setting CLR_INT2 clears both INT1 and INT2 register bits and reset detecting operation itself.

XDA

1: X axis is disabled for detection.

0: X axis is enabled for detection.

YDA

1: Y axis is disabled for detection.

0: Y axis is enabled for detection.

ZDA

1: Z axis is disabled for detection.

0: Z axis is enabled for detection.

THOPT (This bit is valid for level detection only, not valid for pulse detection)

0: Threshold value is absolute only

1: Positive/Negative threshold value is available.

DFBW

0: Digital filter band width is 62.5 Hz

1: Digital filter band width is 125 Hz

\$19: Control 2 (Read/Write)

D7	D6	D5	D4	D3	D2	D1	D0	Bit
					DRVO	PDPL	LDPL	Function
0	0	0	0	0	0	0	0	Default

LDPL

0: Level detection polarity is positive and detecting condition is OR 3 axes.

1: Level detection polarity is negative detecting condition is AND 3 axes.

PDPL

0: Pulse detection polarity is positive and detecting condition is OR 3 axes.

1: Pulse detection polarity is negative and detecting condition is AND 3 axes.

DRVO

0: Standard drive strength on SDA/SDO pin

1: Strong drive strength on SDA/SDO pin

\$1A: Level detection threshold limit value (Read/Write)

D7	D6	D5	D4	D3	D2	D1	D0	Bit
LDTH[7]	LDTH[6]	LDTH[5]	LDTH[4]	LDTH[3]	LDTH[2]	LDTH[1]	LDTH[0]	Function
0	0	0	0	0	0	0	0	Default

LDTH[7:0]: Level detection threshold value. If THOPT bit in Detection Control Register is "0", it is unsigned 7 bits value and LDTH[7] should be "0". If THOPT bit is "1", it is signed 8 bits value.

\$1B: Pulse detection threshold limit value (Read/Write)

D7	D6	D5	D4	D3	D2	D1	D0	Bit
XPDTH	PDTH[6]	PDTH[5]	PDTH[4]	PDTH[3]	PDTH[2]	PDTH[1]	PDTH[0]	Function
0	0	0	0	0	0	0	0	Default

PDTH[6:0]: Pulse detection threshold value (unsigned 7 bits).

XPDTH: This bit should be "0".

\$1C: Pulse duration value (Read/Write)

D7	D6	D5	D4	D3	D2	D1	D0	Bit
PD[7]	PD[6]	PD[5]	PD[4]	PD[3]	PD[2]	PD[1]	PD[0]	Function
0	0	0	0	0	0	0	0	Default

Min: PD[7:0] = 4'h01 = 0.5 ms

Max: PD[7:0] = 4'hFF = 127 ms

1 LSB = 0.5 ms

\$1D: Latency time value (Read/Write)

D7	D6	D5	D4	D3	D2	D1	D0	Bit
LT[7]	LT[6]	LT[5]	LT[4]	LT[3]	LT[2]	LT[1]	LT[0]	Function
0	0	0	0	0	0	0	0	Default

Min: LT[7:0] = 8'h01 = 1 ms

Max: LT[7:0] = 8'hFF = 255 ms

1 LSB = 1 ms

\$1E: Time window for 2nd pulse value (Read/Write)

D7	D6	D5	D4	D3	D2	D1	D0	Bit
TW[7]	TW[6]	TW[5]	TW[4]	TW[3]	TW[2]	TW[1]	TW[0]	Function
0	0	0	0	0	0	0	0	Default

Min: TW[7:0] = 8'h01 = 1 ms (Single pulse detection)

Max: TW[7:0] = 8'hFF = 255 ms

1 LSB = 1 ms

SENSING DIRECTION AND OUTPUT RESPONSE

The following figure shows sensing direction and the output response for 2g mode.

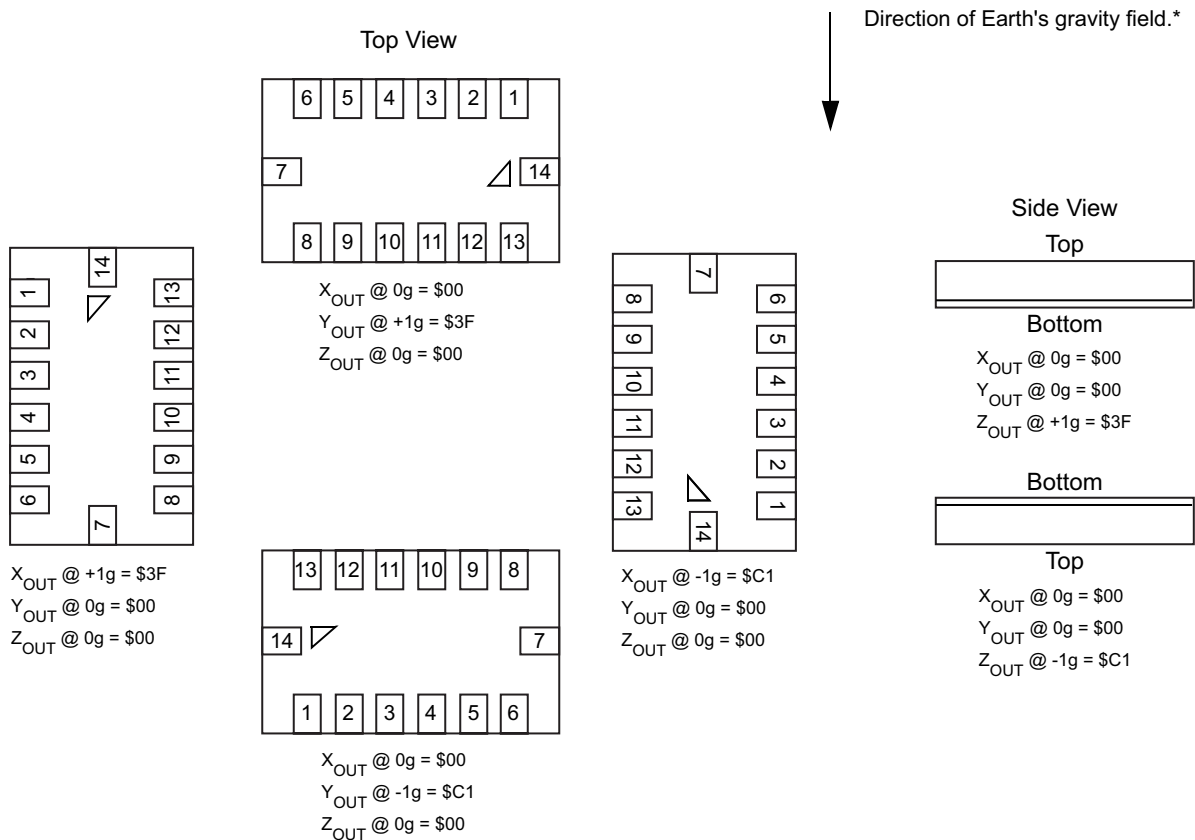

* When positioned as shown, the Earth's gravity will result in a positive 1g output.

Figure 18. Sensing Direction and Output Response at 2g Mode

Table 7. Acceleration vs. Output

FS Mode	Acceleration	Output
2g Mode	-2g	\$80
	-1g	\$C1
	0g	\$00
	+1g	\$3F
	+2g	\$7F
4g Mode	-4g	\$80
	-1g	\$E1
	0g	\$00
	+1g	\$1F
	+4g	\$7F
8g Mode	-8g	\$80
	-1g	\$F1
	0g	\$00
	+1g	\$0F
	+8g	\$7F

MINIMUM RECOMMENDED FOOTPRINT FOR SURFACE MOUNTED APPLICATIONS

Surface mount board layout is a critical portion of the total design. The footprint for the surface mount packages must be the correct size to ensure proper solder connection interface between the board and the package.

With the correct footprint, the packages will self-align when subjected to a solder reflow process. It is always recommended to design boards with a solder mask layer to avoid bridging and shorting between solder pads.

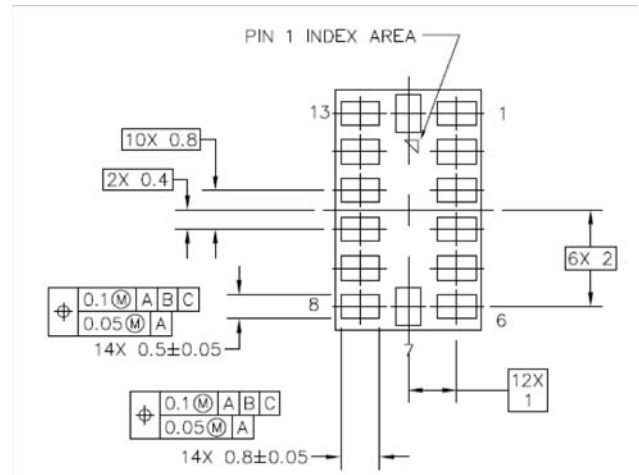

SOLDERING AND MOUNTING GUIDELINES FOR THE LGA ACCELEROMETER SENSOR TO A PC BOARD

These guideline are for soldering and mounting the LGA package inertial sensors to printed circuit boards (PCBs). The purpose is to minimize the stress on the package after board mounting. Both the MMA73x0L 3 axis analog output family of accelerometers and the MMA7455L digital output accelerometer use the Land Grid Array (LGA) package platform. This section describes suggested methods of soldering these devices to the PC board for consumer applications. Figure 19 shows the recommended PCB land pattern for the package.

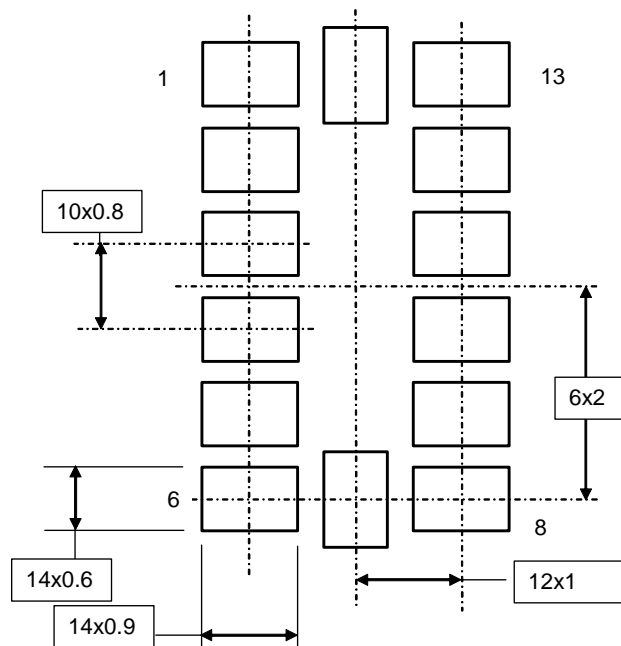

Figure 19. Recommended PCB Land Pattern for the 5 x 3 mm LGA Package

OVERVIEW OF SOLDERING CONSIDERATIONS

Information provided here is based on experiments executed on LGA devices. They do not represent exact conditions present at a customer site. Hence, information herein should be used as a guidance only and process and design optimizations are recommended to develop an application specific solution. It should be noted that with the proper PCB footprint and solder stencil designs the package will self-align during the solder reflow process.

The following are the recommended guidelines to follow for mounting LGA sensors for consumer applications.

PCB MOUNTING RECOMMENDATIONS

1. The PCB land should be designed with Non Solder Mask Defined (NSMD) as shown in Figure 22.
2. No additional metal pattern underneath package as shown in Figure 21.
3. PCB land pad is 0.9mm x 0.6mm which is the size of the package pad plus 0.1mm as shown in Figure 22.
4. The solder mask opening is equal to the size of the PCB land pad plus an extra 0.1mm as shown in Figure 22.
5. The stencil aperture size is equal to the PCB land pad – 0.025mm. Also note that for the 4 corner pads the aperture size must be larger for solder balancing as shown in Figure 23 and Figure 24. A 6mil thick stencil is recommended.

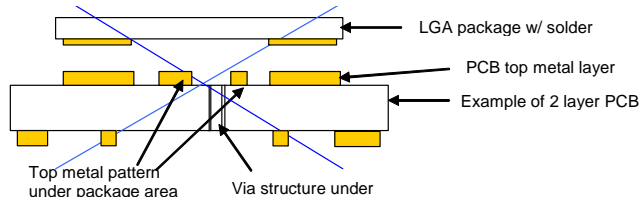
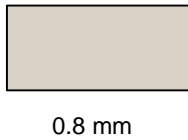

Figure 20. Incorrect PCB Top Metal Pattern Under Package

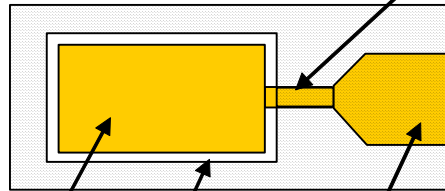

Figure 21. Correct PCB Top Metal Pattern Under Package

Package



PCB land pattern -



Signal trace near package: 0.1mm width and min. 0.5mm length are recommended. Wider trace can be continued after these.

Cu: 0.9 x 0.6 mm sq.

Wider trace

SM opening = PCB land pad + 0.1mm
= 1.0 x 0.7mm sq.

Figure 22. Recommended PCB Land Pad, Solder Mask, and Signal Trace Near Package Design

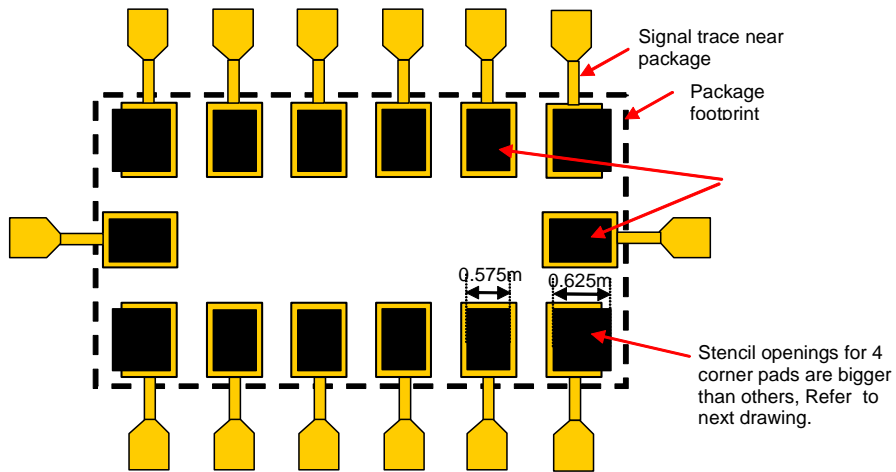

Figure 23. Stencil Design Guidelines

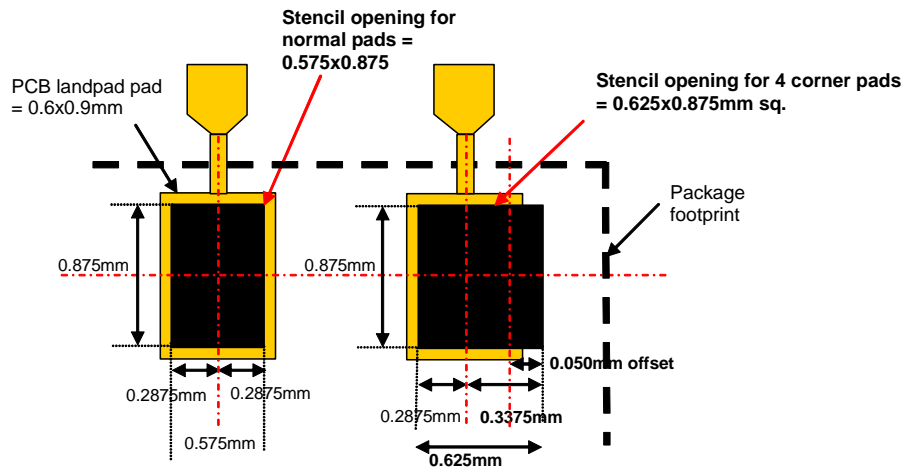

Figure 24. Stencil Design Guidelines (detailed dimensions for corner pads)

6. Do not place any components or vias at a distance less than 2mm from the package land area. This may cause additional package stress if it is too close to the package land area.
7. Signal traces connected to pads should be as symmetric as possible. Put dummy traces on NC pads in order to have same length of exposed trace for all pads. Signal traces with 0.1mm width and min. 0.5mm length for all PCB land pads near the package are recommended as shown in [Figure 22](#), [Figure 23](#), and [Figure 24](#). Wider trace can be continued after the 0.5mm zone.
8. Use a standard pick and place process and equipment. Do not use a hand soldering process.
9. It is recommended to use a cleanable solder paste with an additional cleaning step after SMT mount.
10. Do not use a screw down or stacking to fix the PCB into an enclosure because this could bend the PCB putting stress on the package.
11. The PCB should be rated for the multiple lead-free reflow condition with max 260°C temperature.

Please cross reference with the device data sheet for mounting guidelines specific to the exact device used.

Freescale LGA sensors are compliant with Restrictions on Hazardous Substances (RoHS), having halide free molding compound (green) and lead-free terminations. These terminations are compatible with tin-lead (Sn-Pb) as well as tin-silver-copper (Sn-Ag-Cu) solder paste soldering processes. Reflow profiles applicable to those processes can be used successfully for soldering the devices.

PACKAGE DIMENSIONS

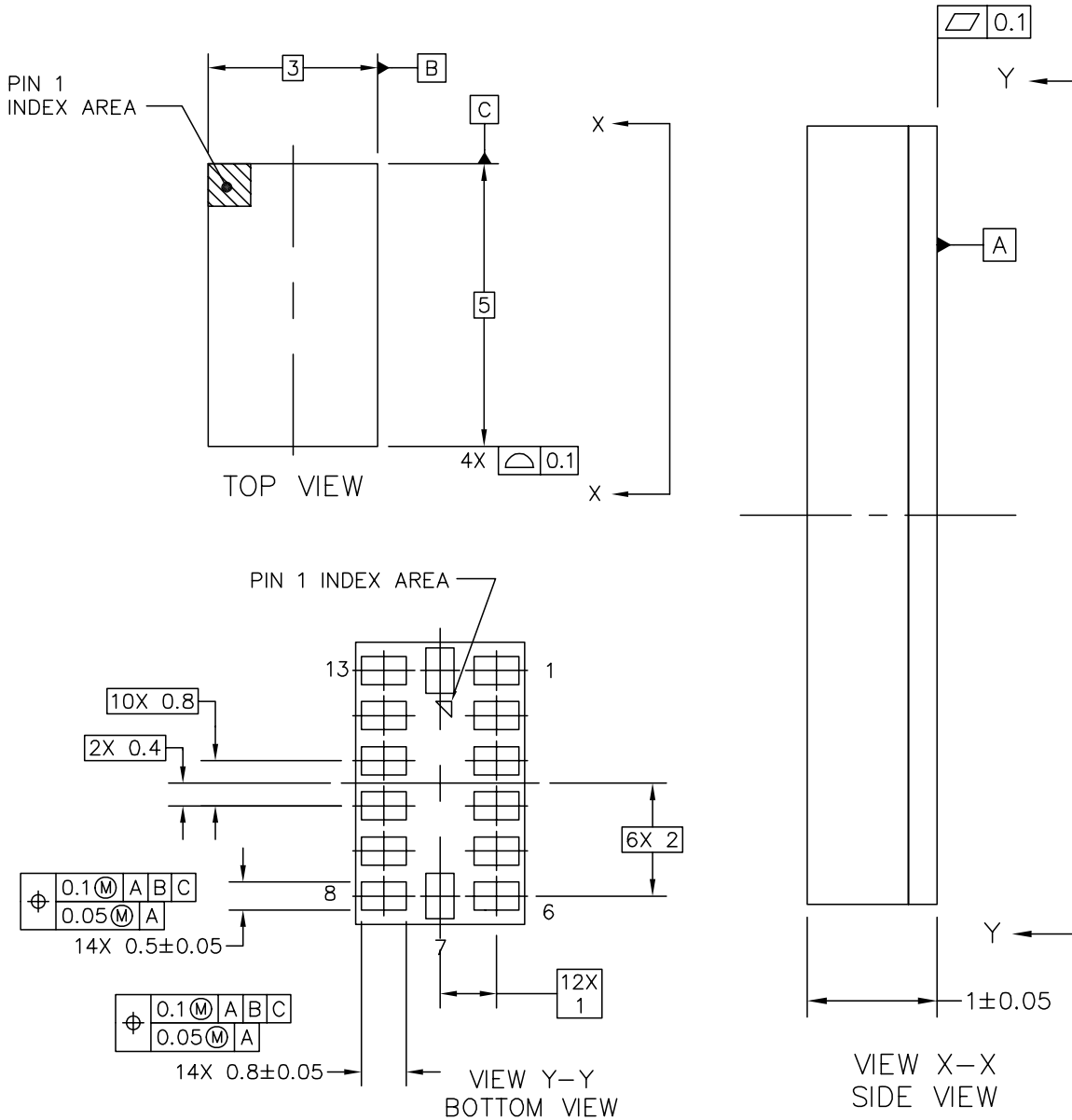

© FREESCALE SEMICONDUCTOR, INC. ALL RIGHTS RESERVED.	MECHANICAL OUTLINE	PRINT VERSION NOT TO SCALE	
TITLE: LGA 14 I/O, 3 X 5 X 1 PITCH 0.8, ION 1.0MM PKG	DOCUMENT NO: 98ASA10801D	REV: 0	
	CASE NUMBER: 1977-01	30 OCT 2007	
	STANDARD: NON-JEDEC		

**CASE 1977-01
ISSUE 0
14-LEAD LGA**

MMA7455L

PACKAGE DIMENSIONS

NOTES:

1. ALL DIMENSIONS IN MILLIMETERS.
2. DIMENSIONING AND TOLERANCING PER ASME Y14.5M-1994.

© FREESCALE SEMICONDUCTOR, INC. ALL RIGHTS RESERVED.	MECHANICAL OUTLINE	PRINT VERSION NOT TO SCALE	
TITLE: LGA 14 I/O, 3 X 5 X 1 PITCH 0.8, ION 1.0MM PKG	DOCUMENT NO: 98ASA10801D	REV: 0	
	CASE NUMBER: 1977-01	30 OCT 2007	
	STANDARD: NON-JEDEC		

**CASE 1977-01
ISSUE 0
14-LEAD LGA**

How to Reach Us:

Home Page:

www.freescale.com

Web Support:

<http://www.freescale.com/support>

USA/Europe or Locations Not Listed:

Freescale Semiconductor, Inc.
Technical Information Center, EL516
2100 East Elliot Road
Tempe, Arizona 85284
+1-800-521-6274 or +1-480-768-2130
www.freescale.com/support

Europe, Middle East, and Africa:

Freescale Halbleiter Deutschland GmbH
Technical Information Center
Schatzbogen 7
81829 Muenchen, Germany
+44 1296 380 456 (English)
+46 8 52200080 (English)
+49 89 92103 559 (German)
+33 1 69 35 48 48 (French)
www.freescale.com/support

Japan:

Freescale Semiconductor Japan Ltd.
Headquarters
ARCO Tower 15F
1-8-1, Shimo-Meguro, Meguro-ku,
Tokyo 153-0064
Japan
0120 191014 or +81 3 5437 9125
support.japan@freescale.com

Asia/Pacific:

Freescale Semiconductor Hong Kong Ltd.
Technical Information Center
2 Dai King Street
Tai Po Industrial Estate
Tai Po, N.T., Hong Kong
+800 2666 8080
support.asia@freescale.com

For Literature Requests Only:

Freescale Semiconductor Literature Distribution Center
P.O. Box 5405
Denver, Colorado 80217
1-800-441-2447 or 303-675-2140
Fax: 303-675-2150
LDCForFreescaleSemiconductor@hibbertgroup.com

Information in this document is provided solely to enable system and software implementers to use Freescale Semiconductor products. There are no express or implied copyright licenses granted hereunder to design or fabricate any integrated circuits or integrated circuits based on the information in this document.

Freescale Semiconductor reserves the right to make changes without further notice to any products herein. Freescale Semiconductor makes no warranty, representation or guarantee regarding the suitability of its products for any particular purpose, nor does Freescale Semiconductor assume any liability arising out of the application or use of any product or circuit, and specifically disclaims any and all liability, including without limitation consequential or incidental damages. "Typical" parameters that may be provided in Freescale Semiconductor data sheets and/or specifications can and do vary in different applications and actual performance may vary over time. All operating parameters, including "Typicals", must be validated for each customer application by customer's technical experts. Freescale Semiconductor does not convey any license under its patent rights nor the rights of others. Freescale Semiconductor products are not designed, intended, or authorized for use as components in systems intended for surgical implant into the body, or other applications intended to support or sustain life, or for any other application in which the failure of the Freescale Semiconductor product could create a situation where personal injury or death may occur. Should Buyer purchase or use Freescale Semiconductor products for any such unintended or unauthorized application, Buyer shall indemnify and hold Freescale Semiconductor and its officers, employees, subsidiaries, affiliates, and distributors harmless against all claims, costs, damages, and expenses, and reasonable attorney fees arising out of, directly or indirectly, any claim of personal injury or death associated with such unintended or unauthorized use, even if such claim alleges that Freescale Semiconductor was negligent regarding the design or manufacture of the part.

Freescale™ and the Freescale logo are trademarks of Freescale Semiconductor, Inc. All other product or service names are the property of their respective owners.

© Freescale Semiconductor, Inc. 2007. All rights reserved.

RoHS-compliant and/or Pb-free versions of Freescale products have the functionality and electrical characteristics of their non-RoHS-compliant and/or non-Pb-free counterparts. For further information, see <http://www.freescale.com> or contact your Freescale sales representative.

For information on Freescale's Environmental Products program, go to <http://www.freescale.com/epp>.