

Programmable NiCd/NiMH Fast-Charge Management Device

Features

- Safe management of fast charge for NiCd and NiMH
- High-frequency switching controller for efficient and simple charger design
- Pre-charge qualification for detecting shorted, damaged, or overheated cells
- Fast-charge termination by $\Delta T/\Delta t$ maximum temperature, and maximum charge time
- Selectable top-off mode for achieving maximum capacity in NiMH batteries
- Programmable trickle-charge mode for reviving deeply discharged batteries and for post-charge maintenance
- Built-in battery removal and insertion detection
- Sleep mode for low power consumption

General Description

The bq24401 is a programmable, monolithic IC for fast-charge management of nickel cadmium (NiCd) and nickel metal-hydride (NiMH).

Depending on the chemistry, the bq24401 provides a number of charge termination criteria:

- Rate of temperature rise, $\Delta T/\Delta t$ (for NiCd and NiMH)
- Maximum temperature
- Maximum charge time

For safety, the bq24401 inhibits fast charge until the battery voltage and temperature are within user-defined limits. If the battery voltage is below the low-voltage threshold, the bq24401 uses trickle-charge to condition the battery. For NiMH batteries, the bq24401 provides an optional top-off charge to maximize the battery capacity.

The integrated high-frequency comparator allows the bq24401 to be the basis for a complete, high-efficiency power-conversion circuit.

Pin Connections

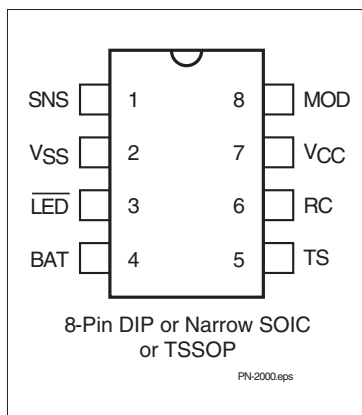

Pin Names

SNS	Current-sense input	TS	Temperature-sense input
VSS	System ground	RC	Timer-program input
$\overline{\text{LED}}$	Charge-status output	VCC	Supply-voltage input
BAT	Battery-voltage input	MOD	Modulation-control output

bq24401

Pin Descriptions

<p>SNS Current-sense input</p> <p>Enables the bq24401 to sense the battery current via the voltage developed on this pin by an external sense-resistor connected in series with the battery pack</p> <p>Vss System Ground</p> <p>$\overline{\text{LED}}$ Charge-status output</p> <p>Open-drain output that indicates the charging status by turning on, turning off, or flashing an external LED</p> <p>BAT Battery-voltage input</p> <p>Battery-voltage sense input. A simple resistive divider, across the battery terminals, generates this input.</p> <p>TS Temperature-sense input</p> <p>Input for an external battery-temperature monitoring circuit. An external resistive divider network with a negative temperature-coefficient thermistor sets the lower and upper temperature thresholds.</p>	<p>RC Timer-program input</p> <p>RC input used to program the maximum charge-time, hold-off period, and trickle rate during the charge cycle, and to disable or enable top-off charge</p> <p>VCC Supply-voltage input</p> <p>MOD Modulation-control output</p> <p>Push-pull output that controls the charging current to the battery. MOD switches high to enable charging current to flow and low to inhibit charging-current flow.</p>
---	---

Functional Description

The bq24401 is a versatile, NiCd, NiMH battery-charge control device. See Figure 1 for a functional block diagram and Figure 2 for the state diagram.

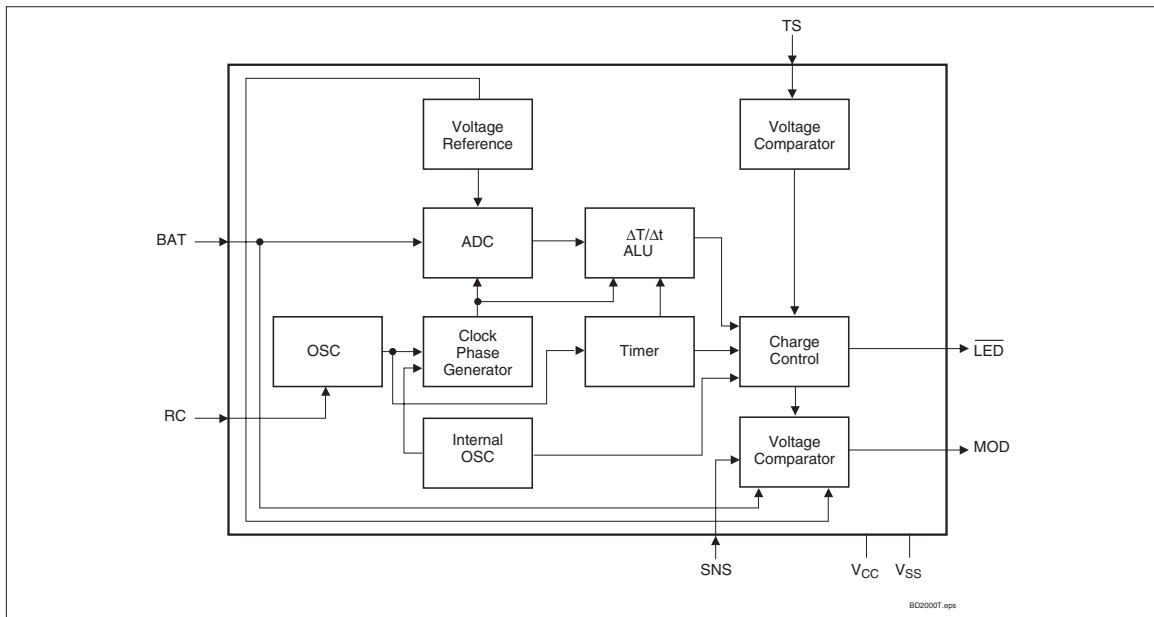

Figure 1. Functional Block Diagram

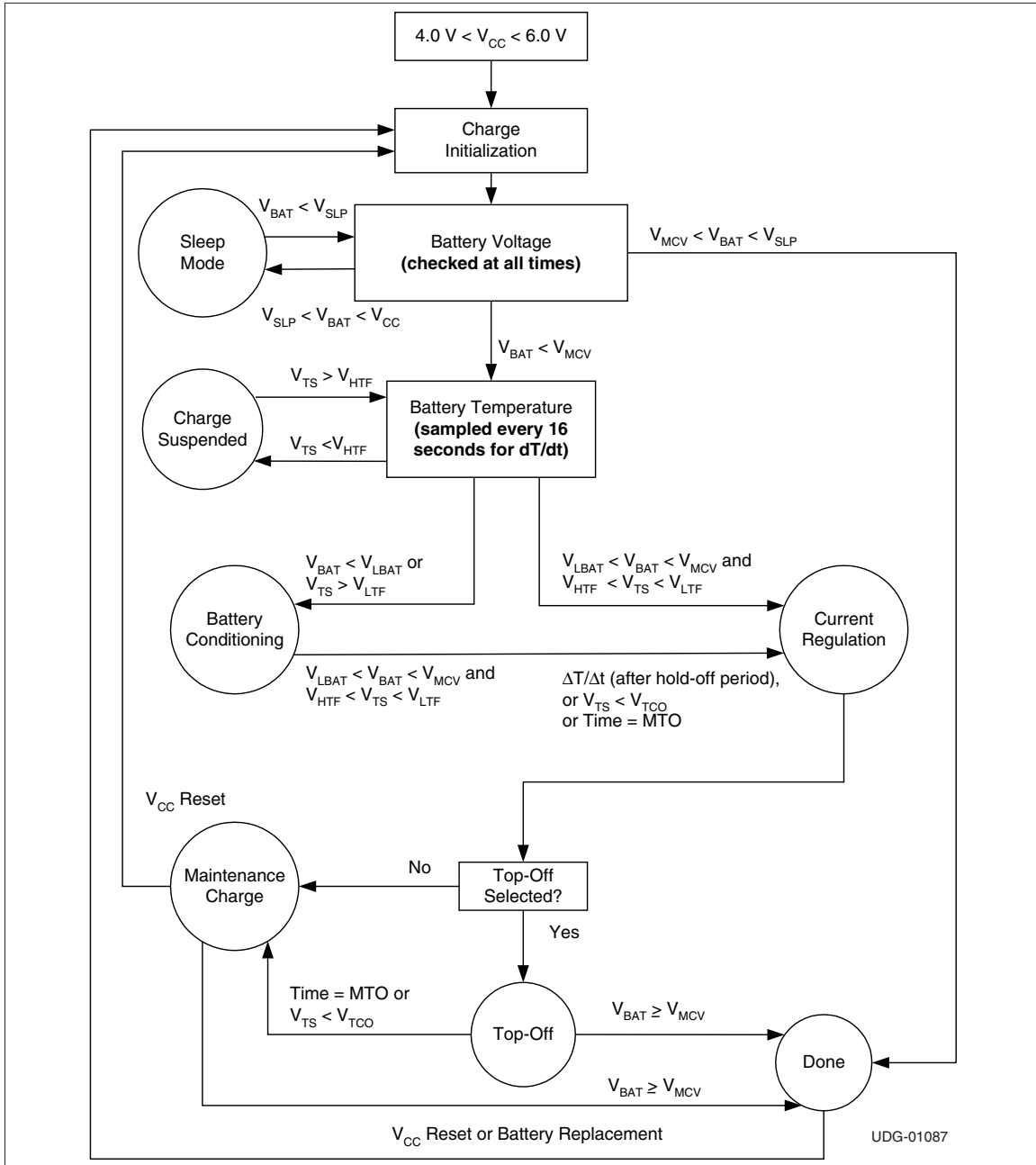

Figure 2. State Diagram

bq24401

Initiation and Charge Qualification

The bq24401 initiates a charge cycle when it detects

- Application of power to V_{CC}
- Battery replacement
- Exit from sleep mode

Immediately following initiation, the IC enters a charge-qualification mode. The bq24401 charge qualification is based on battery voltage and temperature. If voltage on pin BAT is less than the internal threshold, V_{LBAT} , the bq24401 enters the charge-pending state. This condition indicates the possibility of a defective or shorted battery pack. In an attempt to revive a fully depleted pack, the bq24401 enables the MOD pin to trickle-charge at a rate of once every 1.0s. As explained in the section “Top-Off and Pulse-Trickle Charge,” the trickle pulse-width is user-selectable and is set by the value of the resistance connected to pin RC.

During this period, the \overline{LED} pin blinks at a 1Hz rate, indicating the pending status of the charger.

Similarly, the bq24401 suspends fast charge if the battery temperature is outside the V_{LTF} to V_{HTF} range. (See Table 4.) For safety reasons, however, it disables the pulse trickle, in the case of a battery over-temperature condition (i.e., $V_{TS} < V_{HTF}$). Fast charge begins when the battery temperature and voltage are valid.

NiCd and NiMH Batteries

Following qualification, the bq24401 fast-charges NiCd or NiMH batteries using a current-limited algorithm. During the fast-charge period, it monitors charge time, temperature, and voltage for adherence to the termination criteria. This monitoring is further explained in later sections. Following fast charge, the battery is topped off, if top-off is selected. The charging cycle ends with a trickle maintenance-charge that continues as long as the voltage on pin BAT remains below V_{MCV} .

Charge Termination

Maximum Charge Time

The bq24401 sets the maximum charge-time through pin RC. With the proper selection of external resistor and capacitor, various time-out values may be achieved. Figure 3 shows a typical connection.

The following equation shows the relationship between the R_{MTO} and C_{MTO} values and the maximum charge time (MTO) for the bq24401:

$$MTO = R_{MTO} * C_{MTO} * 35,988$$

MTO is measured in minutes, R_{MTO} in ohms, and C_{MTO} in farads.

(**Note:** R_{MTO} and C_{MTO} values also determine other features of the device. See Tables 2 and 3 for details.)

Maximum Temperature

A negative-coefficient thermistor, referenced to V_{SS} and placed in thermal contact with the battery, may be used as a temperature-sensing device. Figure 4 shows a typical temperature-sensing circuit.

During fast charge, the bq24401 compares the battery temperature to an internal high-temperature cutoff threshold, V_{TCO} . As shown in Table 4, high-temperature termination occurs when voltage at pin TS is less than this threshold.

$\Delta T/\Delta t$

When fast charging, the bq24401 monitors the voltage at pin TS for rate of temperature change detection, $\Delta T/\Delta t$. The bq24401 samples the voltage at the TS pin every 16s and compares it to the value measured 2 samples earlier. This feature terminates fast charge if this voltage declines at a rate of

$$\frac{V_{CC}}{161} \left(\frac{V}{\text{Min}} \right)$$

Figure 4 shows a typical connection diagram.

Table 1. Charge Algorithm

Battery Chemistry	Charge Algorithm
NiCd or NiMH	<ol style="list-style-type: none"> 1. Charge qualification 2. Trickle charge, if required 3. Fast charge (constant current) 4. Charge termination ($\Delta T/\Delta t$, time) 5. Top-off (optional) 6. Trickle charge

Table 2. Summary of NiCd or NiMH Charging Characteristics

Parameter	Value
Maximum cell voltage (V_{MCV})	2V
Minimum pre-charge qualification voltage (V_{LBAT})	950mV
High-temperature cutoff voltage (V_{TCO})	$0.225 * V_{CC}$
High-temperature fault voltage (V_{HTF})	$0.25 * V_{CC}$
Low-temperature fault voltage (V_{LTF})	$0.5 * V_{CC}$
bq24401 fast-charge maximum time out (MTO)	$R_{MTO} * C_{MTO} * 35,988$
Fast-charge charging current (I_{MAX})	$0.05/R_{SNS}$
Hold-off period	$MTO/32$
Top-off charging current (optional)	$I_{MAX}/16$
Top-off period (optional)	MTO
Trickle-charge frequency	1Hz
Trickle-charge pulse-width	See Figure 6

Table 3. Temperature-Monitoring Conditions

Temperature	Condition	Action
$V_{TS} > V_{LTF}$	Cold battery—checked at all times	Suspends fast charge or top-off and timer Allows trickle charge—LED flashes at 1Hz rate during pre-charge qualification and fast charge
$V_{HTF} < V_{TS} < V_{LTF}$	Optimal operating range	Allows charging
$V_{TS} < V_{HTF}$	Hot battery—checked during charge qualification and top-off and trickle-charge	Suspends fast-charge initiation, does not allow trickle charge—LED flashes at 1Hz rate during pre-charge qualification
$V_{TS} < V_{TCO}$	Battery exceeding maximum allowable temperature—checked at all times	Terminates fast charge or top-off

Initial Hold-Off Period

The values of the external resistor and capacitor connected to pin RC set the initial hold-off period. During this period, the bq24401 avoids early termination by disabling the $\Delta T/\Delta t$ feature. This period is fixed at the programmed value of the maximum charge time divided by 32.

$$\text{hold-off period} = \frac{\text{maximum time - out}}{32}$$

Table 4. Charge Status Display

Charge Action State	LED Status
Battery absent	High impedance
Pre-charge qualification	1Hz flash
Trickle charge (before fast charge)	1Hz flash
Fast charging	Low
Top-off or trickle	High impedance
Charge complete	High impedance
Sleep mode	High impedance
Charge suspended ($V_{TS} > V_{LTF}$)	1Hz flash

bq24401

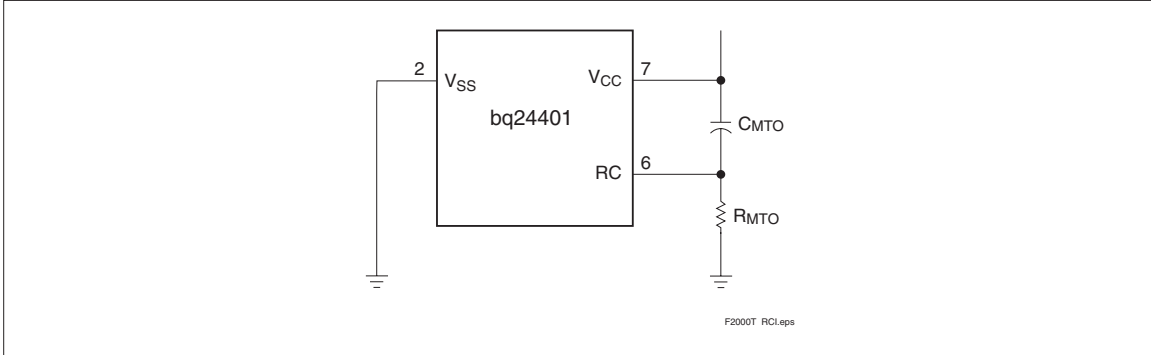

Figure 3. Typical Connection for the RC Input

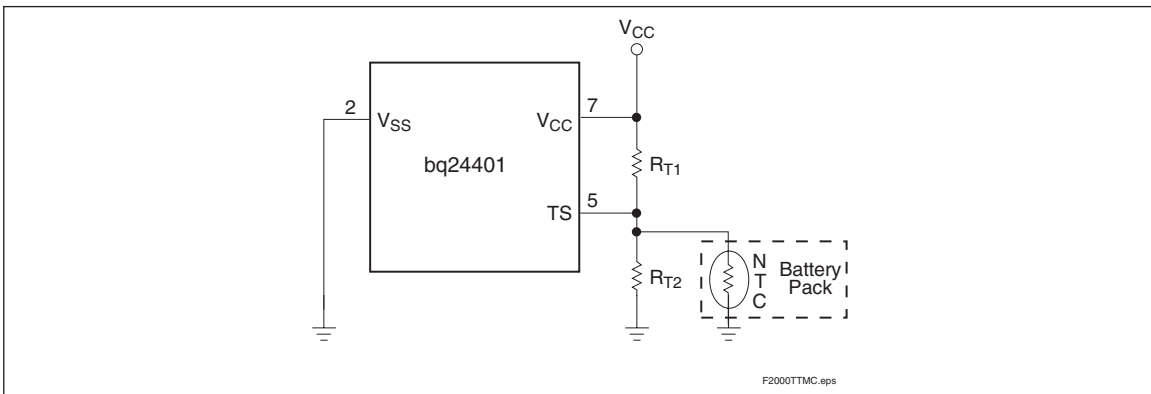

Figure 4. Temperature Monitoring Configuration

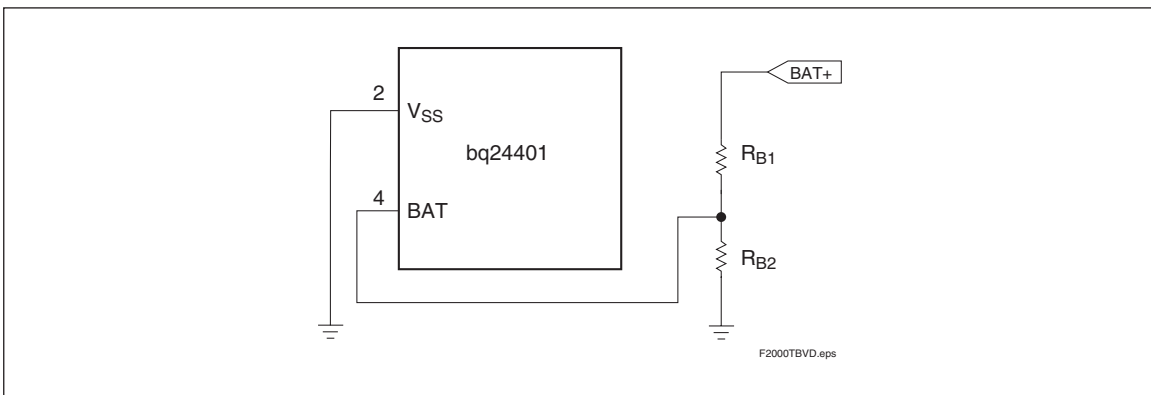

Figure 5. Battery Voltage Divider

Top-Off and Pulse-Trickle Charge

Top-off may be desirable on batteries that have a tendency to terminate charge before reaching full capacity. To enable this option, the capacitance value of C_{MTO} connected to pin RC (Figure 3) should be greater than $0.13\mu\text{F}$, and the value of the resistor connected to this pin should be less than $15\text{k}\Omega$. To disable top-off, the capacitance value should be less than $0.07\mu\text{F}$. The tolerance of the capacitor needs to be taken into account in component selection.

Once enabled, the top-off is performed over a period equal to the maximum charge time at a rate of $1/16$ that of fast charge.

Following top-off, the bq24401 trickle-charges the battery by enabling the MOD to charge at a rate of once every 1.0 second. The trickle pulse-width is user-selectable and is set by the value of the resistor R_{MTO} , which is on pin RC. Figure 6 shows the relationship between the trickle pulse-width and the value of R_{MTO} . The typical tolerance of the pulsewidth below $150\text{k}\Omega$ is $\pm 10\%$.

During top-off and trickle-charge, the bq24401 monitors battery voltage and temperature. These functions are suspended if the battery voltage rises above the maximum cell voltage (V_{MCV}) or if the temperature exceeds the high-temperature fault threshold (V_{HTF}).

Charge Current Control

The bq24401 controls the charge current through the MOD output pin. The current-control circuit supports a switching-current regulator with frequencies up to 500kHz . The bq24401 monitors charge current at the SNS input by the voltage drop across a sense-resistor, R_{SNS} , in series with the battery pack. See Figure 8 for a typical current-sensing circuit. R_{SNS} is sized to provide the desired fast-charge current (I_{MAX}):

$$I_{MAX} = \frac{0.05}{R_{SNS}}$$

If the voltage at the SNS pin is greater than V_{SNSHI} or less than V_{SNSLO} , the bq24401 switches the MOD output high to pass charge current to the battery. When the SNS voltage is less than V_{SNSLO} or greater than V_{SNSHI} , the bq24401 switches the MOD output low to shut off charging current to the battery. Figure 7 shows a typical multi-chemistry charge circuit.

Voltage Input

As shown in Figure 5, a resistor voltage-divider between the battery pack's positive terminal and V_{SS} scales the battery voltage measured at pin BAT.

The resistor values R_{B1} and R_{B2} are calculated by the following equation:

$$\frac{R_{B1}}{R_{B2}} = N - 1$$

where N is the number of cells in series. The end-to-end input impedance of this resistive divider network should be at least $200\text{k}\Omega$ and no more than $1\text{M}\Omega$.

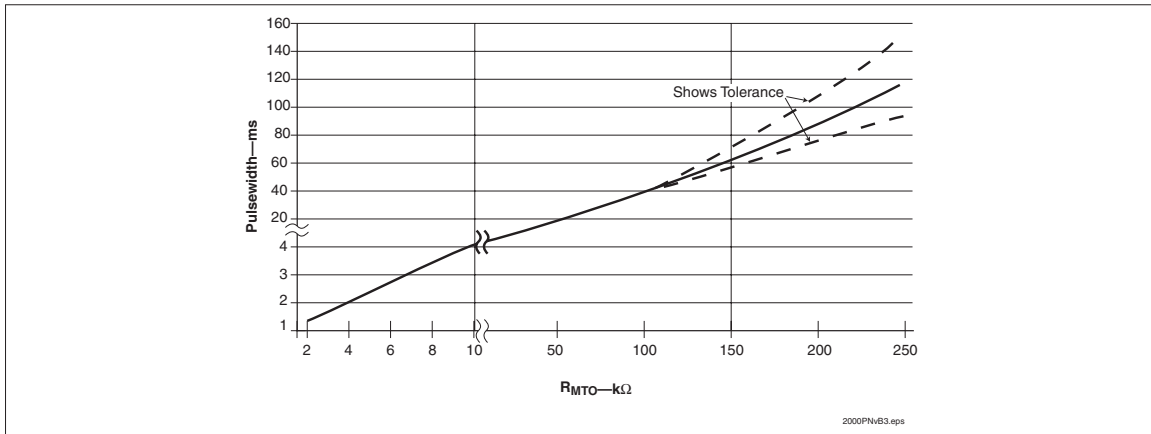

Figure 6. Relationship Between Trickle Pulse-Width and Value of R_{MTO}

bq24401

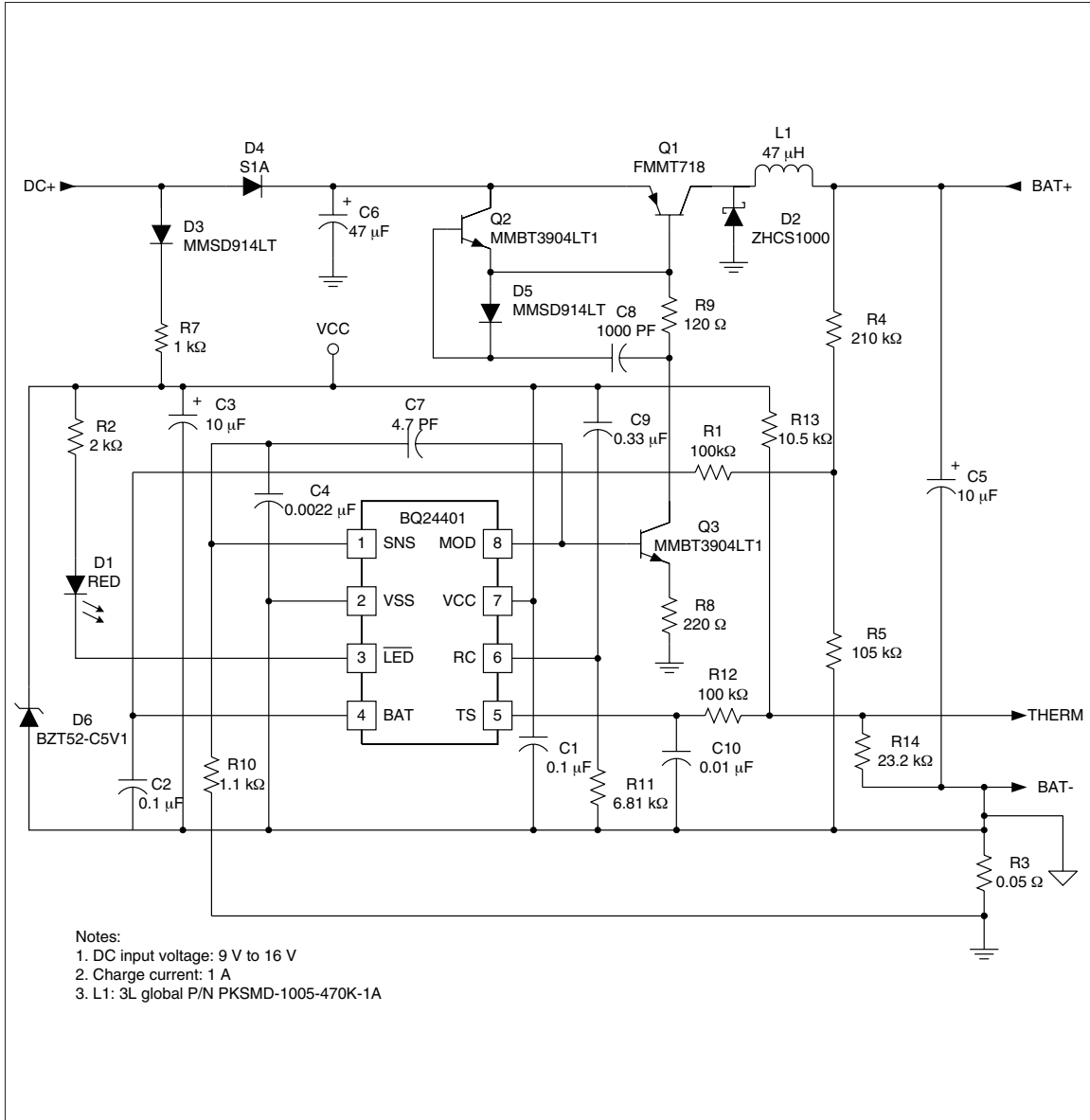

Figure 7. Three-Cell NiCd/NiMH 1A Charger

Temperature Monitoring

The bq24401 measures the temperature by the voltage at the TS pin. This voltage is typically generated by a negative-temperature-coefficient thermistor. The bq24401 compares this voltage against its internal threshold voltages to determine if charging is safe.

These thresholds are the following:

- High-temperature cutoff voltage: $V_{TCO} = 0.225 * V_{CC}$
This voltage corresponds to the maximum temperature (TCO) at which fast charging is allowed. The bq24401 terminates fast charge if the voltage on pin TS falls below V_{TCO} .
- High-temperature fault voltage: $V_{HTF} = 0.25 * V_{CC}$
This voltage corresponds to the temperature (HTF) at which fast charging is allowed to begin.
- Low-temperature fault voltage: $V_{LTF} = 0.5 * V_{CC}$
This voltage corresponds to the minimum temperature (LTF) at which fast charging or top-off is allowed. If the voltage on pin TS rises above V_{LTF} , the bq24401 suspends fast charge or top-off but does not terminate charge. When the voltage falls back below V_{LTF} , fast charge or top-off resumes from the point where suspended. Trickle-charge is allowed during this condition.

Table 3 summarizes these various conditions.

Charge Status Display

The charge status is indicated by open-drain output LED. Table 4 summarizes the display output of the bq24401.

Sleep Mode

The bq24401 features a sleep mode for low power consumption. This mode is enabled when the voltage at pin BAT is above the low-power-mode threshold, V_{SLP} . During sleep mode, the bq24401 shuts down all internal circuits, drives the LED output to high-impedance state, and drives pin MOD to low. Restoring BAT below the V_{MCV} threshold initiates the IC and starts a fast-charge cycle.

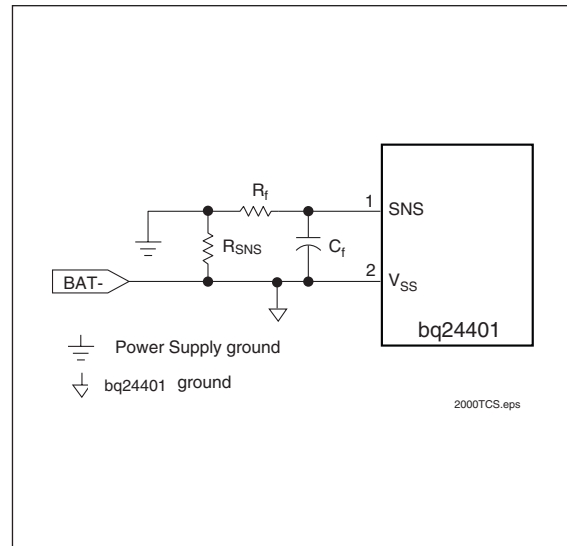

Figure 8. Current-Sensing Circuit

Absolute Maximum Ratings

Symbol	Parameter	Minimum	Maximum	Unit	Notes
V_{CC}	V_{CC} relative to V_{SS}	-0.3	+7.0	V	
V_T	DC voltage applied on any pin, excluding V_{CC} relative to V_{SS}	-0.3	+7.0	V	
T_{OPR}	Operating ambient temperature	-20	+70	°C	
T_{STG}	Storage temperature	-40	+125	°C	
T_{SOLDER}	Soldering temperature	-	+260	°C	10s max.

Note: Permanent device damage may occur if Absolute Maximum Ratings are exceeded. Functional operation should be limited to the Recommended DC Operating Conditions detailed in this data sheet. Exposure to conditions beyond the operational limits for extended periods of time may affect device reliability.

DC Thresholds ($T_A = T_{OPR}$; $V_{CC} = 5V \pm 20\%$ unless otherwise specified)

Symbol	Parameter	Rating	Tolerance	Unit	Notes
V_{TCO}	Temperature cutoff	$0.225 * V_{CC}$	$\pm 5\%$	V	Voltage at pin TS
V_{HTF}	High-temperature fault	$0.25 * V_{CC}$	$\pm 5\%$	V	Voltage at pin TS
V_{LTF}	Low-temperature fault	$0.5 * V_{CC}$	$\pm 5\%$	V	Voltage at pin TS
V_{MCV}	Maximum cell voltage	2.00	$\pm 2.5\%$	V	$V_{BAT} > V_{MCV}$ inhibits fast charge
V_{LBAT}	Minimum cell voltage	950	$\pm 5\%$	mV	Voltage at pin BAT
V_{THERM}	TS input change for $\Delta T/\Delta t$ detection	$-\frac{V_{CC}}{161}$	$\pm 25\%$	V/Min	
V_{SNSHI}	High threshold at SNS, resulting in MOD-low	50	± 10	mV	Voltage at pin SNS
V_{SNSLO}	Low threshold at SNS, resulting in MOD-high	-50	± 10	mV	Voltage at pin SNS
V_{SLP}	Sleep-mode input threshold	$V_{CC} - 1$	± 0.5	V	Applied to pin BAT
V_{RCH}	Recharge threshold	$V_{MCV} - 0.1$	± 0.02	V	At pin BAT

Impedance

Symbol	Parameter	Minimum	Typical	Maximum	Unit
R_{BAT}	Battery input impedance	10	-	-	$M\Omega$
R_{TS}	TS input impedance	10	-	-	$M\Omega$
R_{SNS}	SNS input impedance	10	-	-	$M\Omega$

Timing ($T_A = T_{OPR}$; $V_{CC} = 5V \pm 20\%$ unless otherwise specified)

Symbol	Parameter	Minimum	Typical	Maximum	Unit
d_{MTO}	MTO time-base variation	-5	-	+5	%
f_{TRKL}	Pulse-trickle frequency	0.9	1.0	1.1	Hz

bq24401

Recommended DC Operating Conditions (TA = TOPR)

Symbol	Condition	Minimum	Typical	Maximum	Unit	Notes
V _{CC}	Supply voltage	4.0	5.0	6.0	V	
I _{CC}	Supply current	-	0.5	1	mA	Exclusive of external loads
I _{CCS}	Sleep current	-	-	5	μA	V _{BAT} = V _{SLP}
V _{TS}	Thermistor input	0.5	-	V _{CC}	V	V _{TS} < 0.5V prohibited
V _{OH}	Output high	V _{CC} - 0.2	-	-	V	MOD, I _{OH} = 20mA
V _{OL}	Output low	-	-	0.2	V	MOD, LED, I _{OL} = 20mA
I _{OZ}	High-impedance leakage current	-	-	5	μA	LED
I _{snk}	Sink current	-	-	20	mA	MOD, LED
R _{MTO}	Charge timer resistor	2	-	250	kΩ	
C _{MTO}	Charge timer capacitor	0.001	-	1.0	μF	

Note: All voltages relative to V_{SS} except as noted.

Ordering Information

bq24401

Package Option:

P = 8-pin narrow plastic DIP

D = 8-pin narrow SOIC

PW = 8-pin TSSOP

Device:

bq24401 NiCd/NiMH Fast-Charge IC with ΔT/Δt Detection

8-Pin DIP (P)

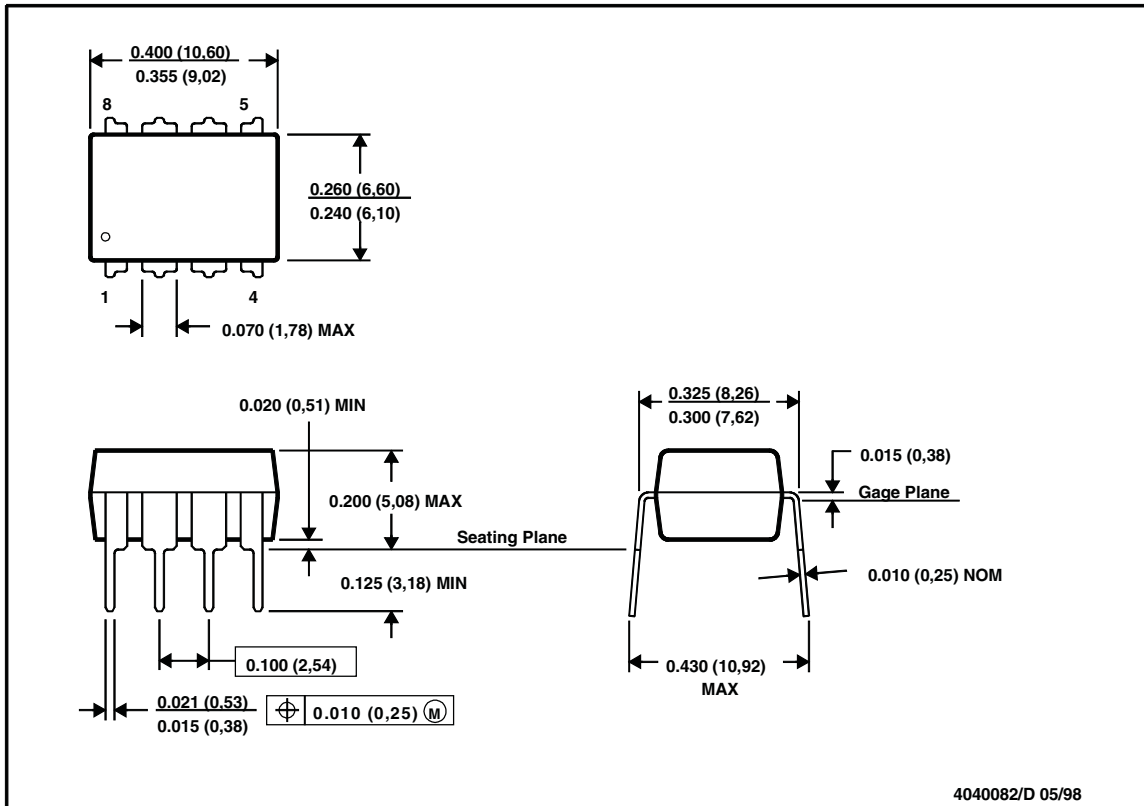

NOTES:

- A. All linear dimensions are in inches (millimeters).
- B. This drawing is subject to change without notice.
- C. Falls within JEDEC MS-001

bq24401

8-Pin SOIC Narrow (D)

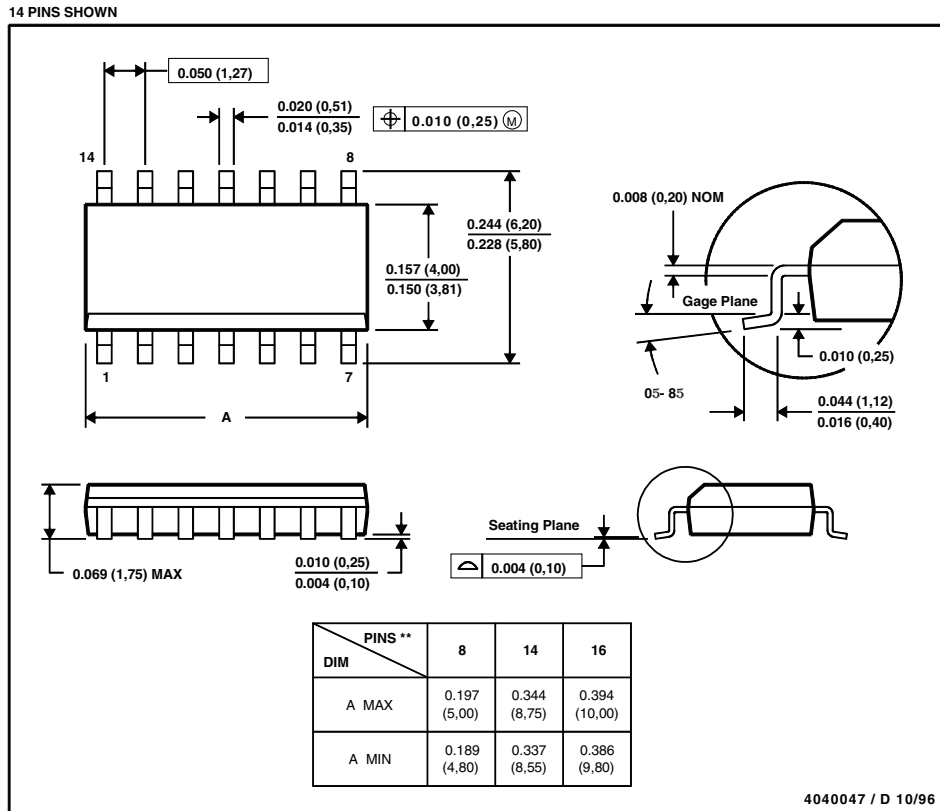

NOTES:

- A. All linear dimensions are in inches (millimeters).
- B. This drawing is subject to change without notice.
- C. Body dimensions do not include mold flash or protrusion, not to exceed 0.006 (0,15).
- D. Falls within JEDEC MS-012

bq24401

8-Pin TSSOP ~ PW Package Suffix

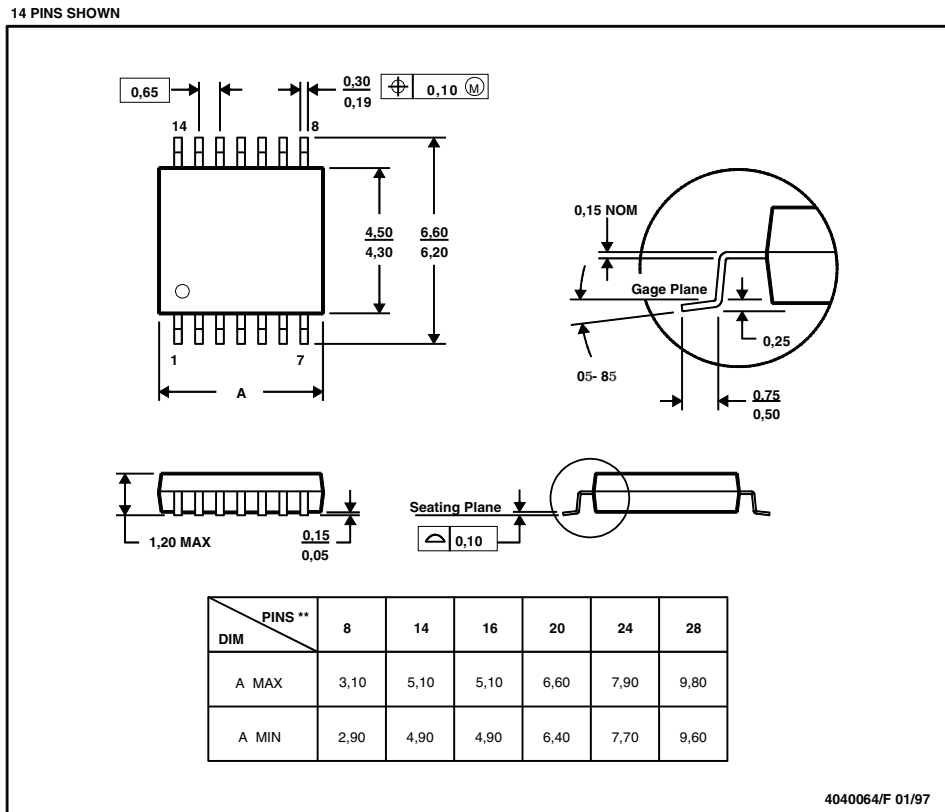

NOTES:

- A. All linear dimensions are in millimeters.
- B. This drawing is subject to change without notice.
- C. Body dimensions do not include mold flash or protrusion not to exceed 0,15.
- D. Falls within JEDEC MO-153

IMPORTANT NOTICE

Texas Instruments and its subsidiaries (TI) reserve the right to make changes to their products or to discontinue any product or service without notice, and advise customers to obtain the latest version of relevant information to verify, before placing orders, that information being relied on is current and complete. All products are sold subject to the terms and conditions of sale supplied at the time of order acknowledgement, including those pertaining to warranty, patent infringement, and limitation of liability.

TI warrants performance of its semiconductor products to the specifications applicable at the time of sale in accordance with TI's standard warranty. Testing and other quality control techniques are utilized to the extent TI deems necessary to support this warranty. Specific testing of all parameters of each device is not necessarily performed, except those mandated by government requirements.

CERTAIN APPLICATIONS USING SEMICONDUCTOR PRODUCTS MAY INVOLVE POTENTIAL RISKS OF DEATH, PERSONAL INJURY, OR SEVERE PROPERTY OR ENVIRONMENTAL DAMAGE ("CRITICAL APPLICATIONS"). TI SEMICONDUCTOR PRODUCTS ARE NOT DESIGNED, AUTHORIZED, OR WARRANTED TO BE SUITABLE FOR USE IN LIFE-SUPPORT DEVICES OR SYSTEMS OR OTHER CRITICAL APPLICATIONS. INCLUSION OF TI PRODUCTS IN SUCH APPLICATIONS IS UNDERSTOOD TO BE FULLY AT THE CUSTOMER'S RISK.

In order to minimize risks associated with the customer's applications, adequate design and operating safeguards must be provided by the customer to minimize inherent or procedural hazards.

TI assumes no liability for applications assistance or customer product design. TI does not warrant or represent that any license, either express or implied, is granted under any patent right, copyright, mask work right, or other intellectual property right of TI covering or relating to any combination, machine, or process in which such semiconductor products or services might be or are used. TI's publication of information regarding any third party's products or services does not constitute TI's approval, warranty or endorsement thereof.