

NO.	MATERIAL	FINISH . REMARKS	NO.	MATERIAL	FINISH . REMARKS
3	BRASS	SURFACE:TIN PLATING 1μmMIN UNDER PLATING: NICKEL PLATING 0.5μmMIN	6	PS	REEL . BLACK
2	BRASS	SURFACE:TIN PLATING 1μmMIN UNDER PLATING: NICKEL PLATING 0.5μmMIN	5	POLYESTER	CLEAR (COVER TAPE)
1	LCP	UL94V-0, BLACK	4	PS	CLEAR (EMBOSSED CARRIER TAPE)

UNITS	SCALE	COUNT	DESCRIPTION OF REVISIONS	DESIGNED	CHECKED	DATE
mm	FREE	2	DIS-H-007104	TS. KUMAZAWA	HK. UMEHARA	12. 08. 06

APPROVED	DATE	DRAWING NO.
HIROSE ELECTRIC CO., LTD.	12. 03. 19	EDC3-343904-01
	12. 03. 19	PART NO. DF57H-2P-1. 2V(21)
	12. 03. 19	CODE NO. CL666-0104-7-21
	12. 03. 19	

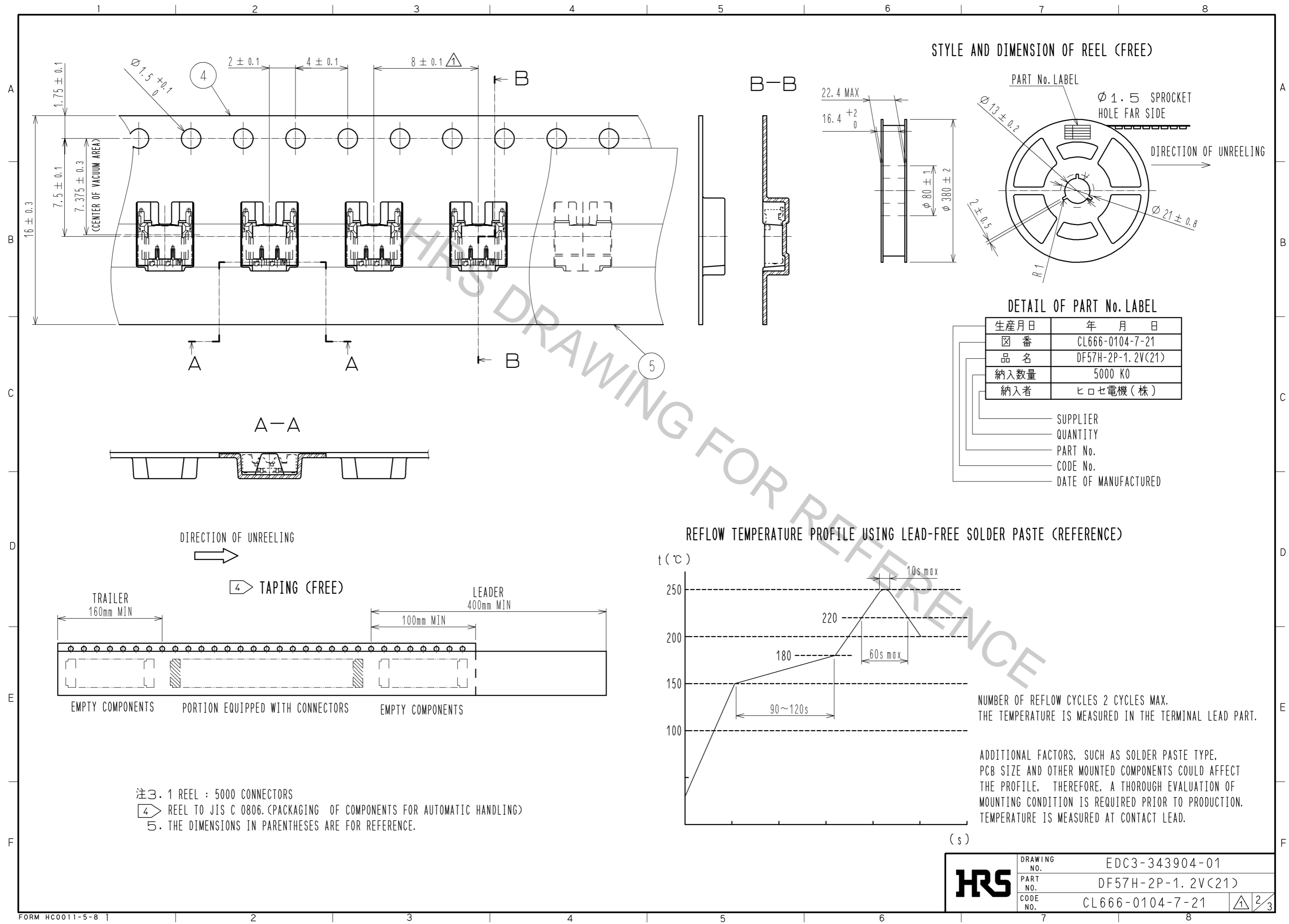

<b>HRS</b>	DRAWING NO.	EDC3-343904-01
	PART NO.	DF57H-2P-1.2V(21)
	CODE NO.	CL666-0104-7-21
		2/3

# DF57 Series Mating / Unmating Operation Instruction

## Mating

① By positioning the convexity of the socket sides to the header concavity, align the centers of the socket and the header in pitch direction.

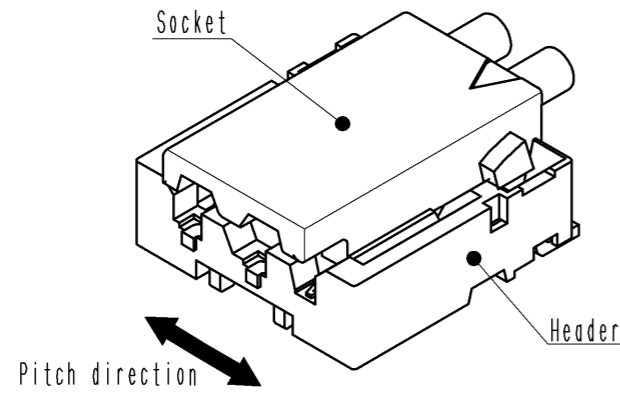

② Slightly press the socket down at cable side to tilted angle.

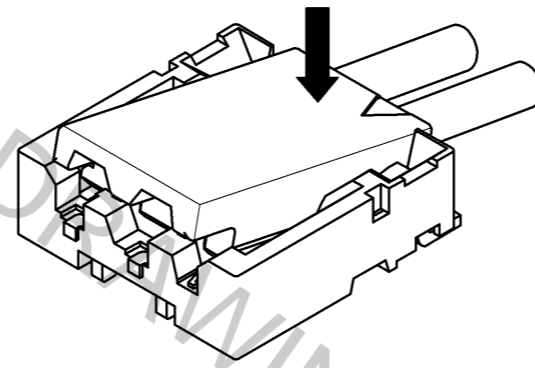

③ Press down at the lever side with stabilizing the cable side to insert. Mating completes.

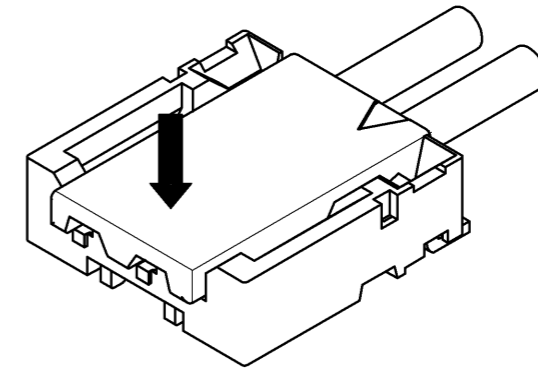

## Unmating

① Hook the lever with finger nail.

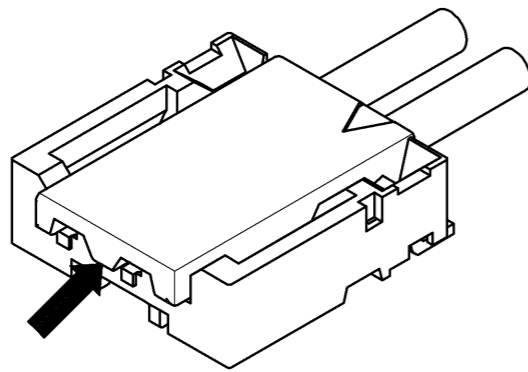

② Lift up to the upper direction and friction lock is released.

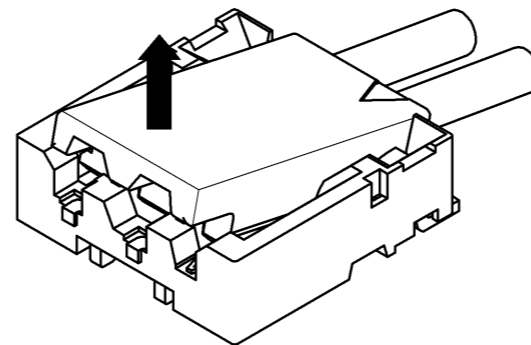

③ Lift up to the upper direction and positive lock is released. Removal completes.

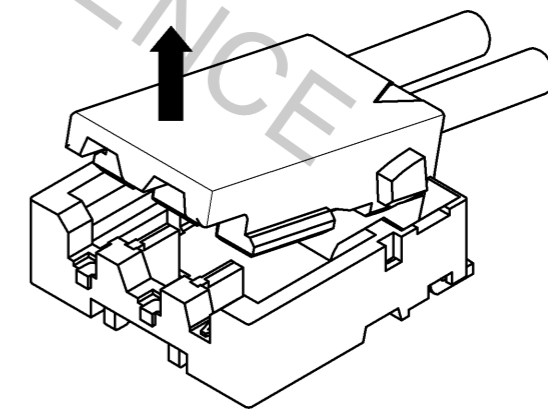

**HRS**

DRAWING NO.	EDC3-343904-01
PART NO.	DF57H-2P-1.2V(21)
CODE NO.	CL666-0104-7-21

3/3