

LBAV99LT1G

S-LBAV99LT1G

Dual Series Switching Diode

1. FEATURES

- We declare that the material of product compliance with RoHS requirements and Halogen Free.
- S- prefix for automotive and other applications requiring unique site and control change requirements; AEC-Q101 qualified and PPAP capable.

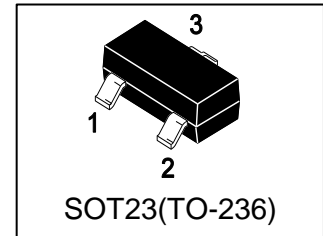

2. DEVICE MARKING AND ORDERING INFORMATION

Device	Marking	Shipping
LBAV99LT1G	A7	3000/Tape&Reel
LBAV99LT3G	A7	10000/Tape&Reel

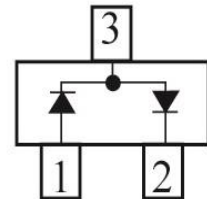

3. MAXIMUM RATINGS(Ta = 25°C)

Parameter	Symbol	Limits	Unit
Reverse Voltage	VR	75	V
Forward Current	IF	215	mA
Peak Forward Surge Current	IFM(surge)	500	mA
Repetitive Peak Reverse Voltage	VRRM	70	V
Average Rectified Forward Current (averaged over any 20 ms period)	IF(AV)	715	mA
Repetitive Peak Forward Current	IFRM	500	mA
Non-Repetitive Peak Forward Current	IFSM		A
t=1μs		2	
t=1ms		1	
t=1s		0.5	

4. THERMAL CHARACTERISTICS

Parameter	Symbol	Limits	Unit
Total Device Dissipation, FR-4 Board (Note 1) @ TA = 25°C Derate above 25°C	PD	225 1.8	mW mW/°C
Thermal Resistance, Junction-to-Ambient(Note 1)	RθJA	556	°C/W
Junction and Storage temperature	TJ,Tstg	-65~+150	°C

1. FR-4 = 1.0×0.75×0.062 in.

5. ELECTRICAL CHARACTERISTICS (Ta= 25°C)

Characteristic	Symbol	Min.	Typ.	Max.	Unit
Reverse Breakdown Voltage (I(BR)=100μA)	VBR	70	-	-	V
Forward Voltage (IF = 1.0 mAdc)	VF	-	-	715	mV
(IF = 10 mAdc)		-	-	855	
(IF = 50 mAdc)		-	-	1000	
(IF = 150 mAdc)		-	-	1250	
Reverse Voltage Leakage Current (VR = 70Vdc)	IR	-	-	2.5	μA
(VR = 70Vdc, TJ = 150°C)		-	-	50	
(VR = 25Vdc, TJ = 150°C)		-	-	30	
Diode Capacitance (VR = 0V, f = 1.0 MHz)	CD	-	-	2.0	pF
Reverse Recovery Time (IF=IR=10mAd,RL =50Ω)	trr	-	-	6.0	ns
Forward Recovery Voltage (IF = 10 mAdc, tr = 20 ns)	VFR	-	-	1.75	V

6. ELECTRICAL CHARACTERISTICS CURVES

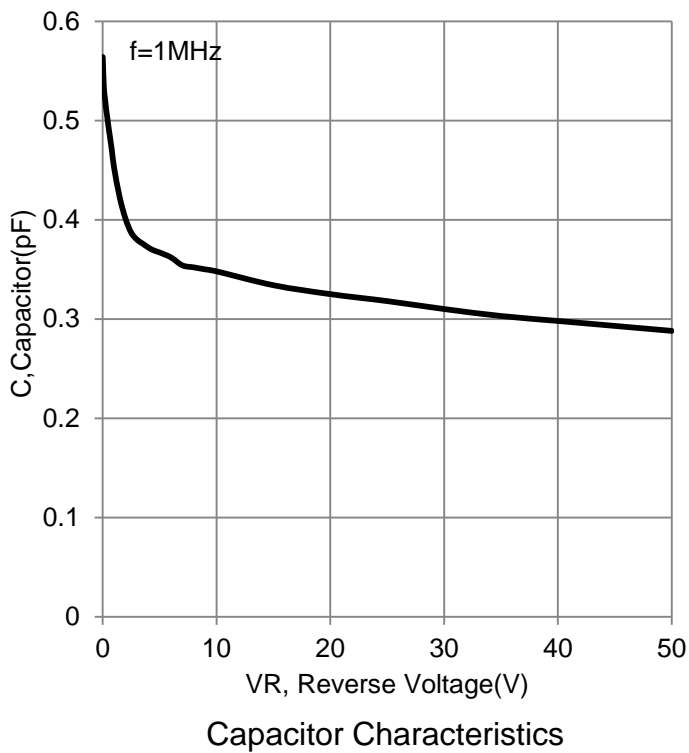
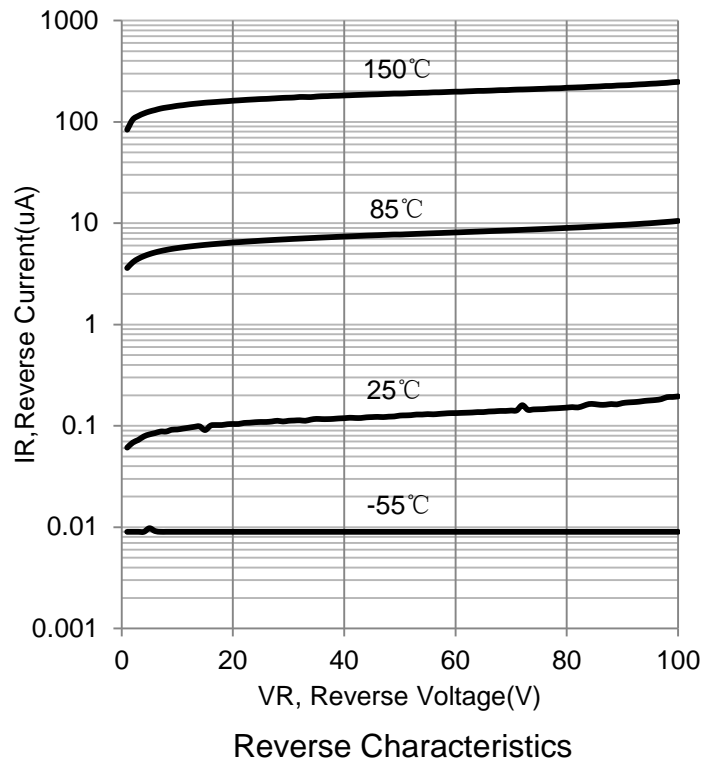
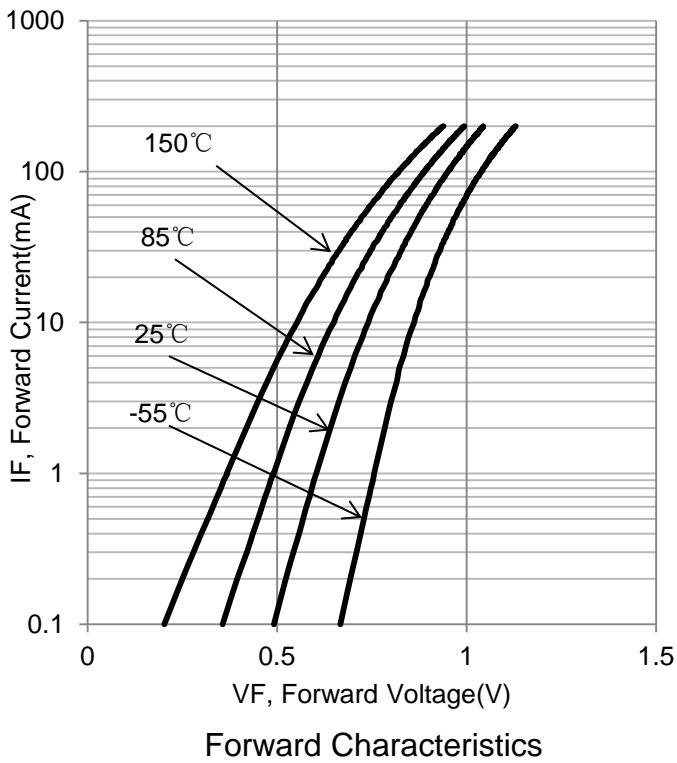

7. OUTLINE AND DIMENSIONS

Notes:

1. DIMENSIONING AND TOLERANCING PER ANSI Y14.5M, 1982.
2. CONTROLLING DIMENSION: MILLIMETERS.
3. MAXIMUM LEAD THICKNESS INCLUDES LEAD FINISH. MINIMUM LEAD THICKNESS IS THE MINIMUM THICKNESS OF BASE MATERIAL.
4. DIMENSIONS D AND E DO NOT INCLUDE MOLD FLASH, PROTRUSIONS OR GATE BURRS.

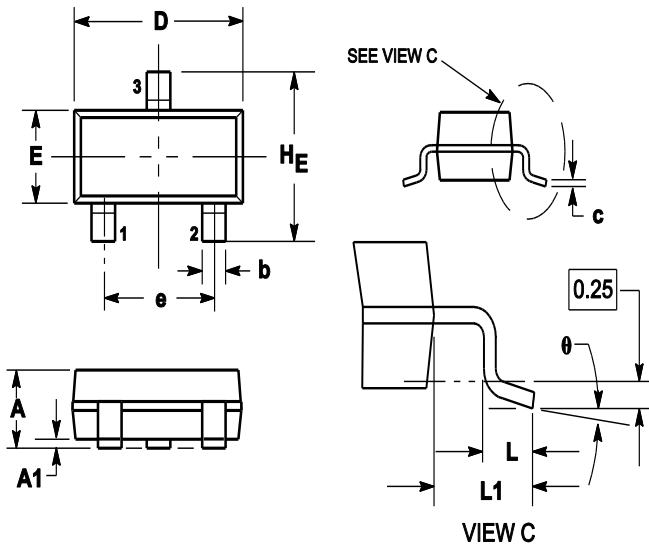

DIM	MILLIMETERS			INCHES		
	MIN	NOM	MAX	MIN	NOM	MAX
A	0.89	1	1.11	0.035	0.04	0.044
A1	0.01	0.06	0.1	0.001	0.002	0.004
b	0.37	0.44	0.5	0.015	0.018	0.02
c	0.09	0.13	0.18	0.003	0.005	0.007
D	2.80	2.9	3.04	0.11	0.114	0.12
E	1.20	1.3	1.4	0.047	0.051	0.055
e	1.78	1.9	2.04	0.07	0.075	0.081
L	0.10	0.2	0.3	0.004	0.008	0.012
L1	0.35	0.54	0.69	0.014	0.021	0.029
HE	2.10	2.4	2.64	0.083	0.094	0.104
θ	0°	---	10°	0°	---	10°

8. SOLDERING FOOTPRINT

