

MAPX	MODIFICATION	DATE
------	--------------	------

SPECIFICATIONS:

Contact current Rating:
 1.8 Amperes for pin1&pin4.
 0.25 Amperes other contacts
 Dielectric Withstanding Voltage:AC 100V(RMS)
 Insulation resistance:100Megohms Minimum.
 Contact Resistance:
 30mΩ Max for pin1&pin4
 50mΩ Max for other contacts
 Mechanical Characteristics:
 Mating Force:35 Newtons,Maximum
 Unmating Force:10 Newtons,Minimum.
MATERIAL:
 8N Min After Durability
 Housing: PBT+30%GF 94V-0 COLOR:SEE TABLE
 Contact: copper alloy (T=0.25mm)
 Shell: SEE TABLE
 PLATING:
 Contact: Au Plated(SEE TABLE) on contact area
 Tin Plated on solder area
 Nickel underplating over all
 Shell: Nickel Plated
 operating Temperature:-55° to+85°

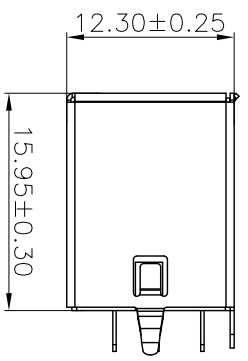
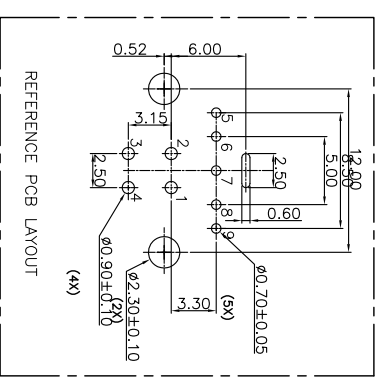
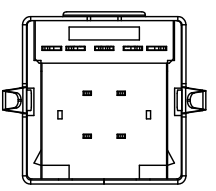
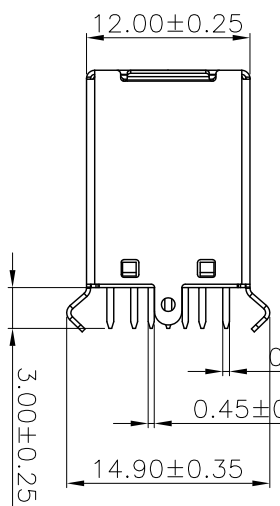
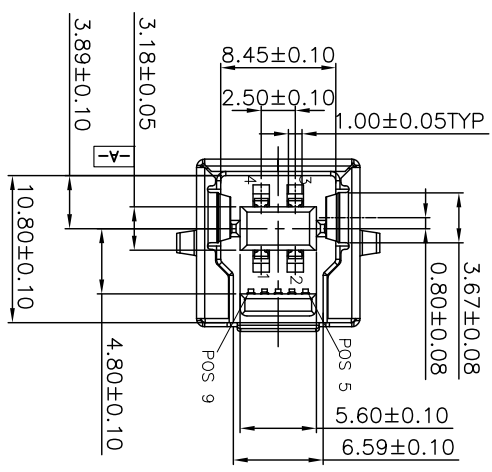
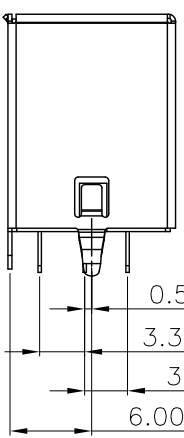
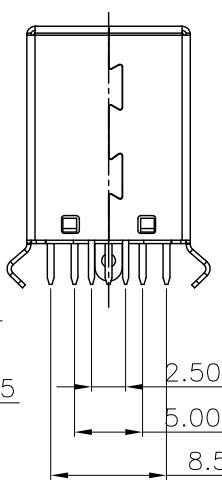
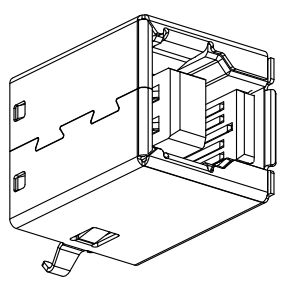

产品图
 PRODUCT CHART DWG
 公差一览表
 TOLERANCE UNLESS OTHERWISE

X	±0.35	X	±5°	单位	MM	制图	Gavin	制料号	USB 3.0 BF 180° DIP
X	±0.30	X	±2°	比例	1:1	审核	郭治富	产品名称	USB 3.0 BF 180° DIP
XX	±0.20	.XX	±1°	日期	2016-06-10	核准	黄国荣	角法	版本
XXX	±0.10	.XXX	±0.5°	DATE		APPD		VIEW	AD

