

# 南京拓微集成电路有限公司

**NanJing Top Power ASIC Corp.**

## DATASHEET

(TP83 Series : Step-up)

## Step-up DC/DC converter —TP83 Series

### Outline

The TP83 series are VFM mode Step-up DC/DC converter with ultra low supply current by CMOS process.

The IC consists of an oscillator,a VFM control circuit,a driver transistor(Lx switch),a reference voltage unit,resistors for voltage detection,an error amplifier,and a Lx switch protection circuit.TP83 series step-up DC/DC converters use VFM mode,comparing to the other congeneric products,it has lower ripple voltage,better driving ability,and higher efficiency.It only needs three external components for application,that is,an inductor,a diode,and a capacitor.

Minimum input voltage is 0.8V, output voltage can be adjusted from 3V to 6V,with a 0.1V step.

### Features /parameters

- I Few external components for application:  
a schottky diode,an inductor,and a capacitor are needed.we strongly advised that,a 20~220uH inductor with low value DC parasitic resistor, a 47~200uF tantalum capacitor,and a schottky diode be used.
- I Ultra low supply current : 4uA
- I Low ripple voltage and low noise : 100mV (typ.)
- I High driving capability : V<sub>typ</sub>=3.3V, V<sub>in</sub>=1.0V, I<sub>out</sub>=100mA  
V<sub>typ</sub>=3.3V, V<sub>in</sub>=3.0V, I<sub>out</sub>=750mA
- I Low start-up voltage : 0.8V
- I High efficiency : 85%(Typ.)
- I Small package : SOT89 / SOT23

### Applications

- I TP83 series are suitable for application where the supply requires low noise and low electromagnetism radiation.
- I Supply portion for battery power supply
- I Power supply portion for toy,camera,VCR,PDA,and portable phone ,etc.
- I Power supply voltage higher than the battery voltage

### Selection Guide

External MOS :

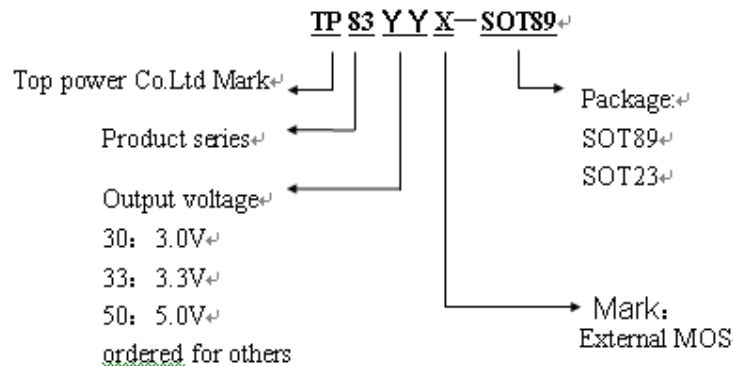

internal MOS :

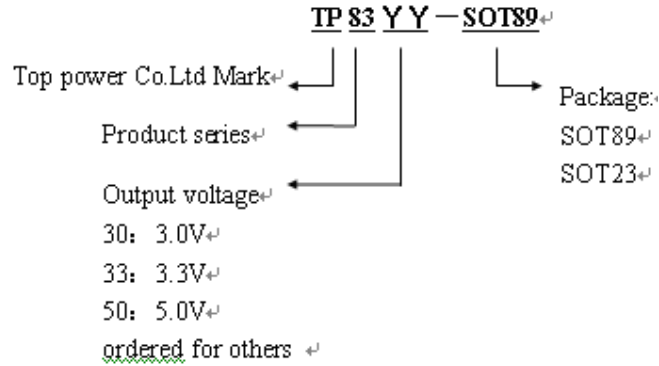

### Pin configuration /Pin description

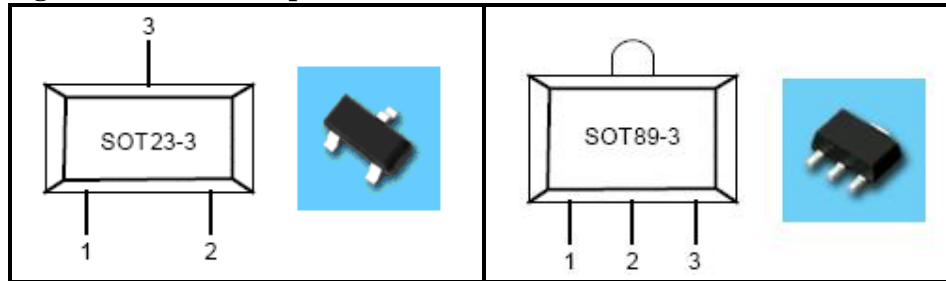

Pin description:

Vss:Ground Pin Lx:Switch Pin(or EXT External MOS) OUT: Output voltage Pin

package	PIN1	PIN2	PIN3
SOT89	Vss	OUT	Lx (EXT)
SOT23	Vss	LX (EXT)	OUT

### Absolute maximum ratings

Symbol	Item	Rating	Unit
VIN	Input Pin Voltage	10	V
Iout	Output Pin Current	800	mA
Pd	Power Dissipation	SOT-23	mW
		SOT-89	
Topt	Operation Temperature	-40~125	°C
Tsolder	Lead Temperature (Soldering 10mS)	260	°C

### Operation of Step-up DC/DC converter

Step-up DC/DC Converter charges energy into the inductor when Lx transistor is on, discharges energy with the addition of the energy from Input Power Source. By this mean, a higher output voltage than the input is obtained.

As follows:

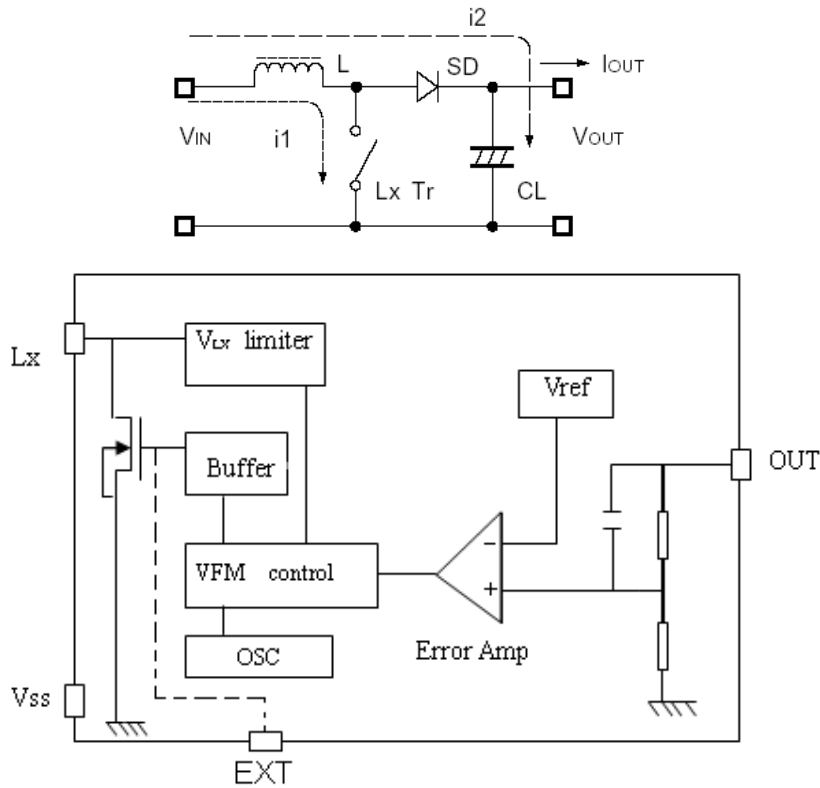

### Electical Characteristics

Test condition:  $V_{IN}=2.2V$ ,  $V_{SS}=0V$ ,  $I_{load}=10mA$ ,  $T_{opt}=25^{\circ}C$ ,  $C=100\mu F$  and  $0.1\mu F$ ,  $L=47\mu H$  (Except especially explained)

TP8330 ( for Fig.1 ) :

Item	Symbol	Conditons	Minimum	Typical	Maximum	Unit
Output Voltage	Vout		2.925	3.000	3.075	V
Start-up Voltage	Vstart	$I_L=1mA$ $V_{IN}: 0 \rightarrow 0.98V$	0.5	0.8	0.9	V
Hold-on Voltage	Vhold	$I_L=1mA$ $V_{IN}: 0.98 \rightarrow 0V$	0.3	0.5	0.6	V
Input Current1	IIN1	$V_{IN}=2.2V$	6	10	25	$\mu A$
Input Current2	IIN2		2	4	8	$\mu A$
Lx Switching Current	ILX	$V_{LX}=0.4V$		450		mA
Lx Leakage Current	ILxleak	$V_{LX}=6V$			1	$\mu A$
Osc Frequency	FOSC		150	200	250	kHz
Duty	Dty			80		%
Efficiency	$\eta$			85		%

TP8333:

Item	Symbol	Conditons	Minimum	Typical	Maximum	Unit
Output Voltage	Vout		3.217	3.300	3.383	V
Start-up Voltage	Vstart	IL=1mA VIN: 0→0.98V	0.5	0.8	0.9	V
Hold-on Voltage	Vhold	IL=1mA VIN: 0.98→0V	0.3	0.5	0.6	V
Input Current1	IIN1	VIN=2.2V	8	10	25	μA
Input Current2	IIN2		2	4	8	μA
Lx Switching Current	ILX	VLX=0.4V		450		mA
Lx Leakage Current	ILxleak	VLX=6V			1	μA
Osc Frequency	FOSC		150	200	250	kHz
Duty	Dty			80		%
Efficiency	η			85		%

TP8350:

Item	Symbol	Conditons	Minimum	Typical	Maximum	Unit
Output Voltage	Vout		4.875	5.000	5.125	V
Start-up Voltage	Vstart	IL=1mA VIN: 0→0.98V	0.5	0.8	0.9	V
Hold-on Voltage	Vhold	IL=1mA VIN: 0.98→0V	0.3	0.5	0.6	V
Input Current1	IIN1	VIN=2.2V	8	15	25	μA
Input Current2	IIN2		2	4		μA
Lx Switching Current	ILX	VLX=0.4V		570		mA
Lx Leakage Current	ILxleak	VLX=6V			1	μA
Osc Frequency	FOSC		150	200	250	kHz
Duty	Dty			80		%
Efficiency	η			85		%

TP8356X(for Fig.2)

Item	Symb ol	Conditons	Minimu m	Typical	Maximu m	Unit
Output Voltage	Vout		5.460	5.600	5.740	V
Input Current1	I <sub>IN1</sub>	V <sub>IN</sub> =2.2V 空载	8	15	25	μA
Input Current2	I <sub>IN2</sub>		1	4	8	μA
CMOS Switching Current	I <sub>EXT N</sub>	V <sub>DS</sub> =0.4V		22		mA
	I <sub>EXT P</sub>	V <sub>DS</sub> =-0.4V		20		mA
Osc Frequency	F <sub>OSC</sub>		150	200	250	kHz
Duty	Dty			80		%

**Typical Characteristics (take TP8330 for example) :**

Test Conditions:  $L=47\mu\text{H}(\text{Ron}=0.1\text{ ohms})$   $C=100\mu\text{F}$  and  $0.1\mu\text{F}$

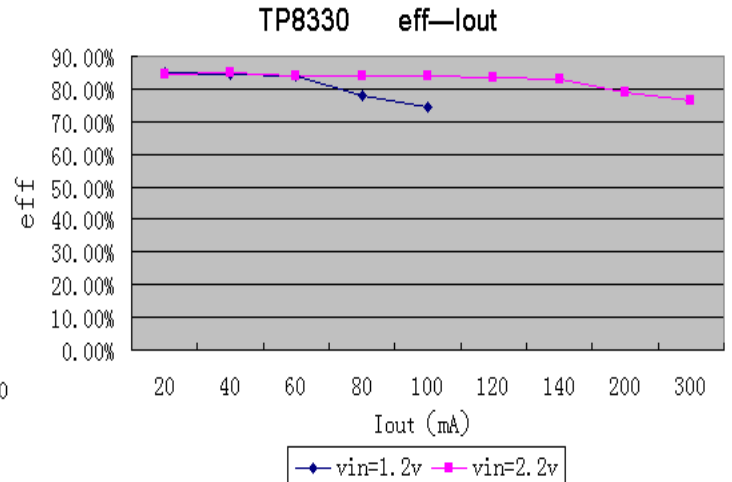
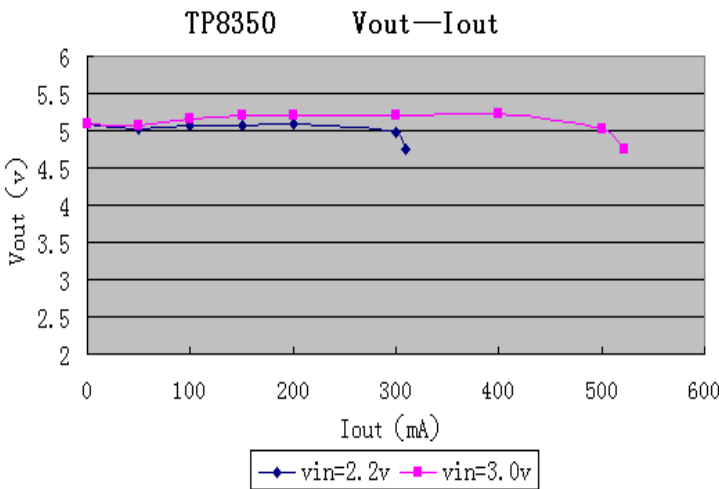
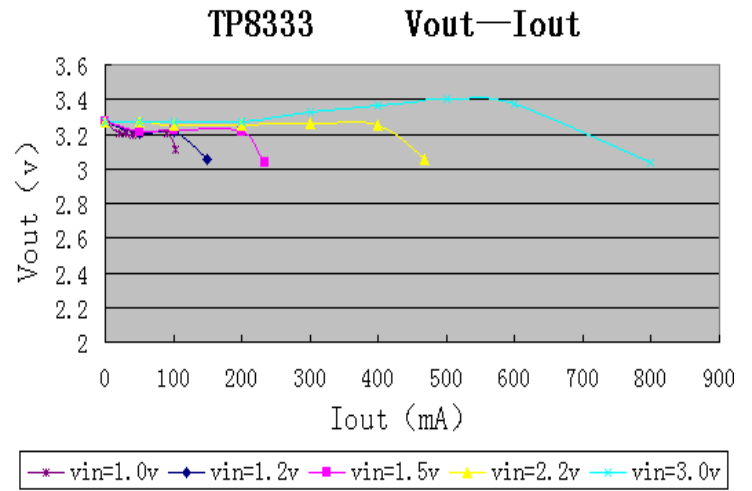
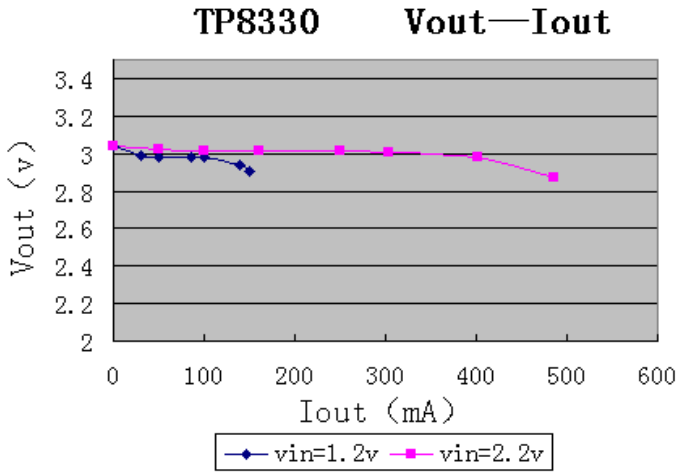

**TP83 series Step-up IC application instance**

Take TP8330 for example:

$L=47\mu\text{H}(\text{Ron}=0.1\text{ohm}), C_{\text{out}}=100\mu\text{F}$  and  $0.1\mu\text{F}$ , Diode: 1N5819

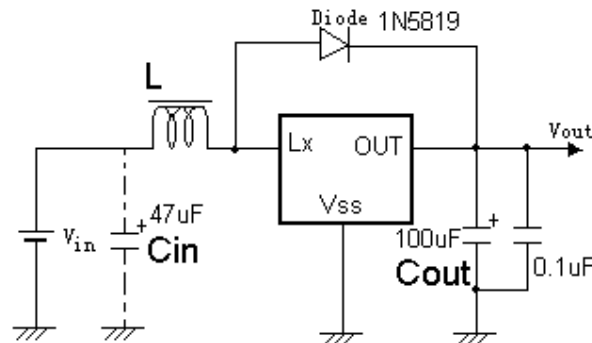

Fig.1:TP8330 application circuit

Take TP8356X for example:

$L=47\mu\text{H}$ ( $R_{on}=0.1\Omega$ ),  $C_{out}=100\mu\text{F}$  and  $0.1\mu\text{F}$ , Diode: 1N5819, NMOS low threshold voltage(GE2300)

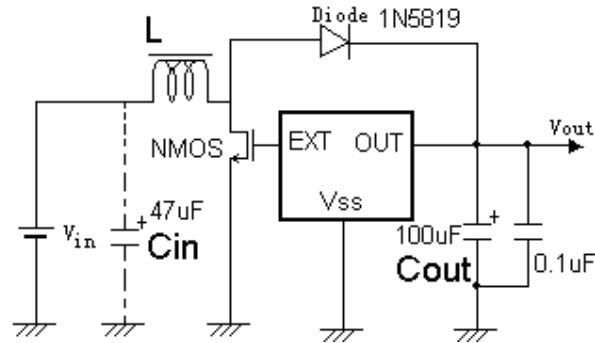
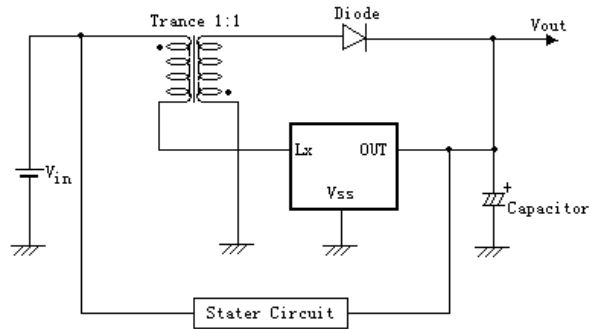
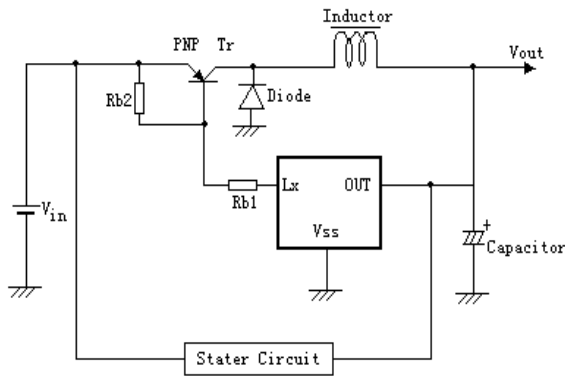

Fig.2: TP8356X application circuit

Step-up circuit:



Step-up/Step-down circuit



Annotate : Start-up circuit for the ascending applications

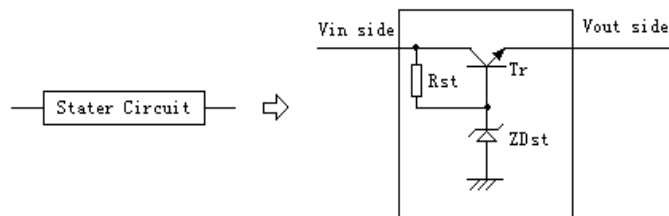

## Attentions

External circuits have great influence on TP83 series Step-up converter IC. Please choose external components carefully following the advice downstairs.

- I External Capacitor  $\geq 47 \mu F$  (Ripple voltage would be very large if the capacitor is too small) . The capacitor should have good frequency response (Tantalum and High frequency capacitor is strongly suggested) . Besides, there will be a Ripple voltage when the Lx switch transistor switches off, so the extreme voltage the capacitor can endure should be no less than three times the design output voltage. (The ESR value of common electrolyze capacitor is too high, so please choose the specified electrolyze capacitor suitable for DC/DC application.
- I External inductor should be small enough in order to store enough energy during the least Lx switch time and lowest input voltage. At the same time, the inductor should be large enough in order not to get ILXMAX out of range during the longest Lx switch time and highest input voltage. Besides, dc resistance of the inductor should be small, the endure current should be high and never get the magnetic saturation.
- I Use a diode of schottky type with high switching speed and also take care of the rated current.
- I The components should be adjacent to the chip, wire should be as short as possible, especially the components connect to the output should have short distance to the capacitor. A 0.1u Ceram capacitor connected between the Output and Ground is strongly suggested.
- I Vss should connect Ground sufficiently, or else the chip's internal Zero voltage would vary by the switch current, and result in instable work state.

## Package

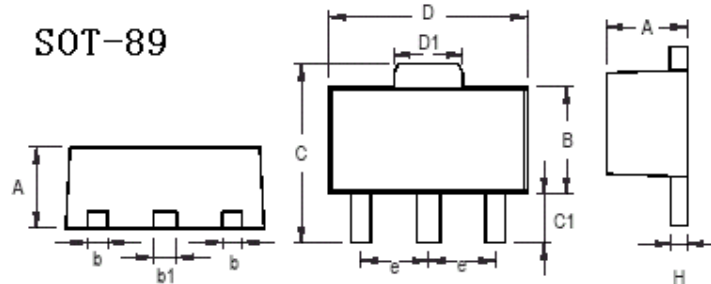

Symbol	Dimensions In Millimeters		Dimensions In Inches	
	Min	Max	Min	Max
A	1.397	1.600	0.055	0.063
b	0.356	0.483	0.014	0.019
B	2.388	2.591	0.094	0.102
b1	0.406	0.533	0.016	0.021
C	--	4.242	--	0.167
C1	0.787	1.194	0.031	0.047
D	4.394	4.597	0.173	0.181
D1	1.397	1.753	0.055	0.069
e	1.448	1.549	0.057	0.061
H	0.355	0.432	0.014	0.017



SOT23

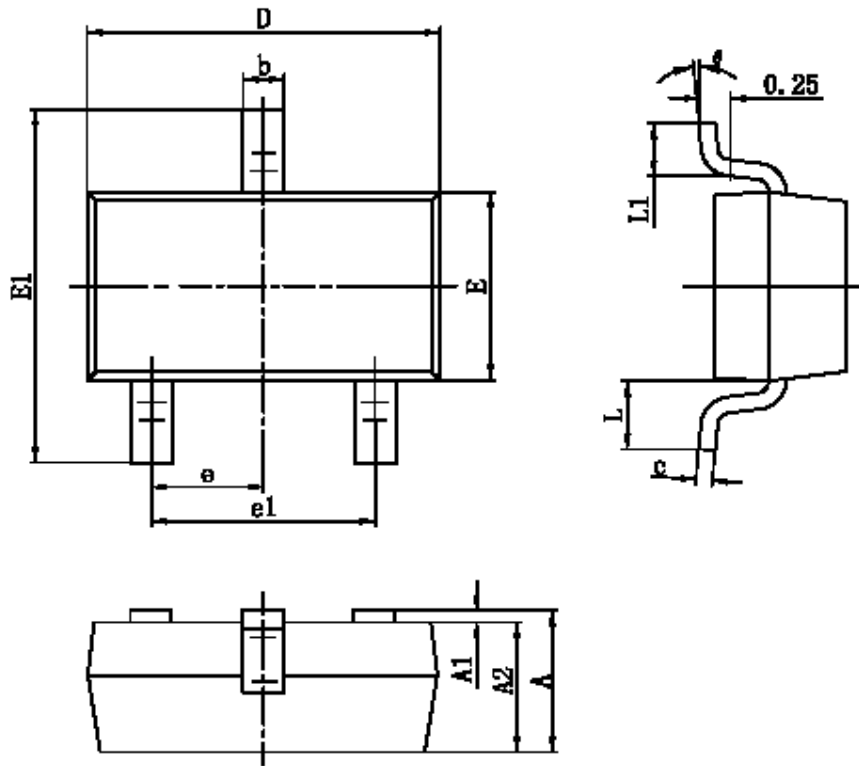

Symbol	Dimensions In Millimeters		Dimensions In Inches	
	Min	Max	Min	Max
A	0.900	1.150	0.035	0.045
A1	0.000	0.100	0.000	0.004
A2	0.900	1.050	0.035	0.041
b	0.300	0.500	0.012	0.020
c	0.080	0.150	0.003	0.006
D	2.800	3.000	0.110	0.118
E	1.200	1.400	0.047	0.055
E1	2.250	2.550	0.089	0.100
e	0.950 TYP		0.037 TYP	
e1	1.800	2.000	0.071	0.079
L	0.550 REF		0.022 REF	
L1	0.300	0.500	0.012	0.020
$\theta$	0°	8°	0°	6°