

规格书 Specification

品名
Model name

HND-2319

PROPRIETARY
Huaneng Electronic co.,Ltd.

CONFIDENTIAL
Huaneng Electronic co.,Ltd.

Version #	Spec V1.0
制作日期 Date	2016/12/16
准备 Prepared	Yang shu yin Acoustic specialist,R&D Dept.
审核 Approved	Zhang chang hua Executive Manager,R&D Dept.



江苏华能电子有限公司

*Components Operating Div.
HuanengElectronic co.,Ltd.*

1.适用范围：本规范适用于HND-2319 9蜂鸣器。

This specifications apply the HND-2319 buzzer.

2.基本规格/General specification

项目/Item	规格/Spec	条件/Condition
1 额定电压 Rated voltage	12VDC	
2 工作电压 Operation voltage	3~24VAC	
3 声压 Sound Pressure Level=SPL	Min 90dB Typical 95dB	测试环境：标准状态，标准驱动电路， 额定电压 测试距离：0.1m Standard State,Standard Drive Circuit. Rated voltage,Distance at 0.1m
4 振荡频率 Oscillation frequency	3700±500Hz	
5 响应时间 Response time	Max 50mS	最低工作电压 Lowest operation voltage
6 工作温度范围 Range of operation temperature	-20~+60°C	声压 ≥90dB SPL ≥90dB
7 保存温度范围 Range of preservation temperature	-30~+70°C	
8 引线强度 Terminal strength	10N	拉负荷方向的终端轴 Pull load on the direction of the terminal axis
9 外部尺寸 Externals size	Φ23x19	参阅附图 Refer to the attached drawing
10 重量 Mass	5g	

☆标准状态：常温（15~35°C），湿度（25~85%相对湿度），空气压力（860~1060hpa）

在假设的情况判断，测试是一基本状态下进行。

Standard State: Ordinary Temp(15~35°C), Humidity(25~85%RH), Air pressure(860~1060hPa)

In case of doubtful judgment, the test is re-performed under Basic State.

☆基本情况：温度。（20±2°C），湿度（60~70%相对湿度），空气压力（860~1060hpa）

Basic State: Temp.(20±2°C), Humidity(60~70%RH), Air pressure(860~1060hPa)

<标准驱动电路>/<Standard Drive Circuit>

<标标测试治具>/<Standard Test Fixture>

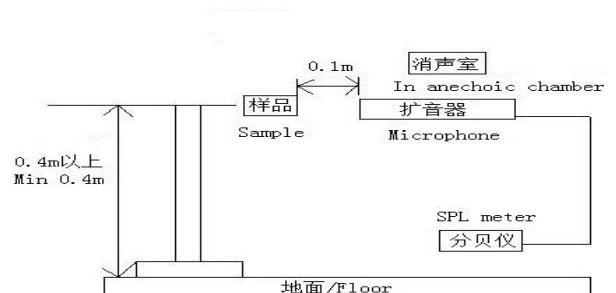
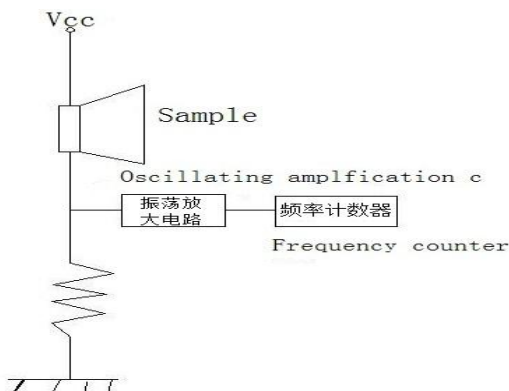

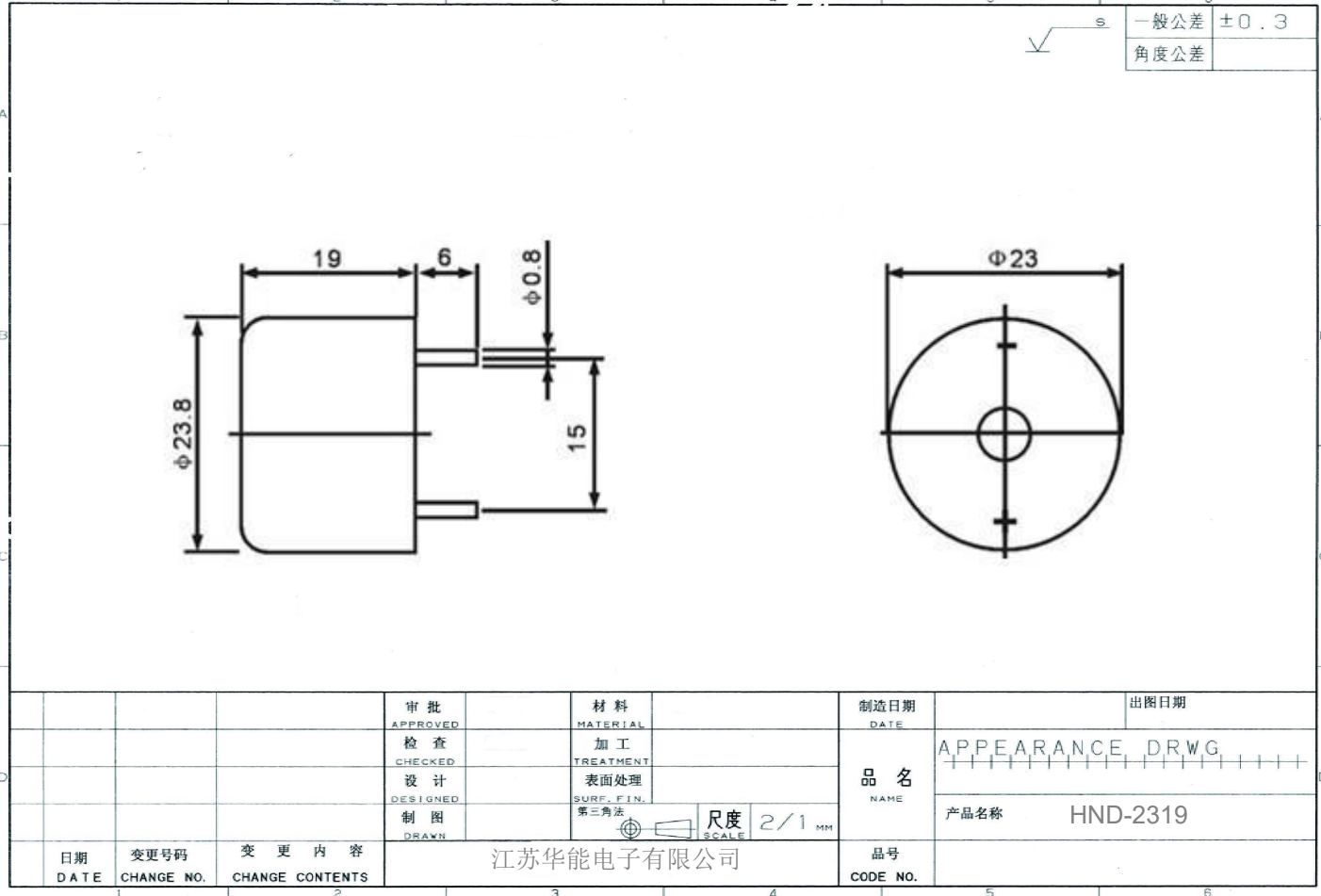

产品频率图

