

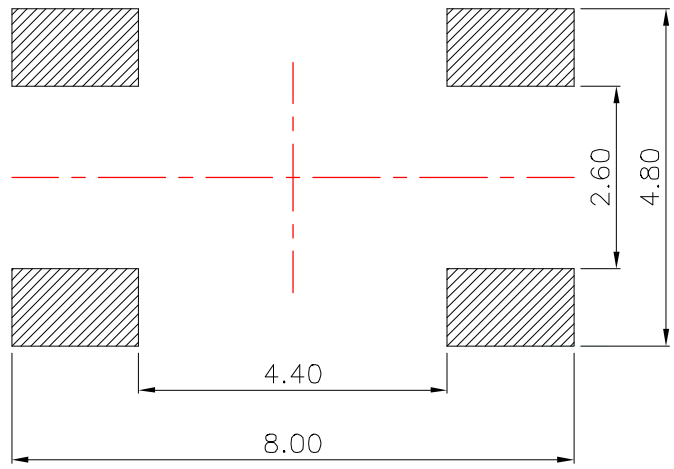

REV.	ECN NO OR DESCRIPTION	REVISED	DATE

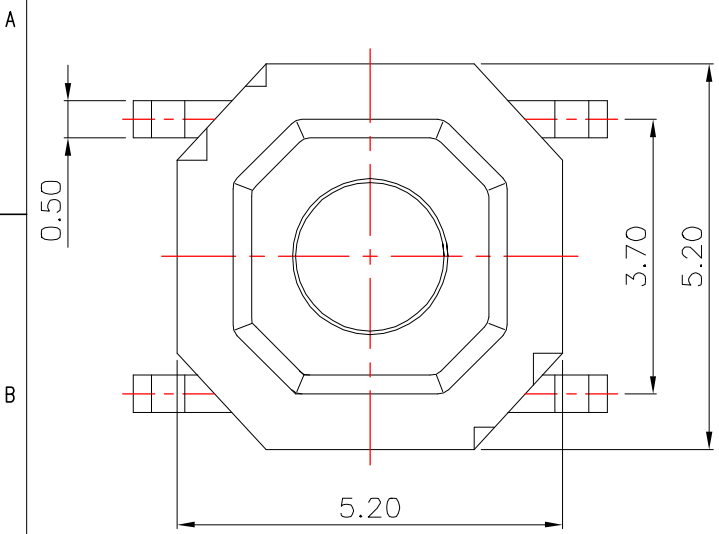

PCB Layout(Pattern side)

product height	
Code	H
15	1.5
16	1.6
17	1.7
20	2.0
25	2.5
30	3.0
35	3.5
43	4.3

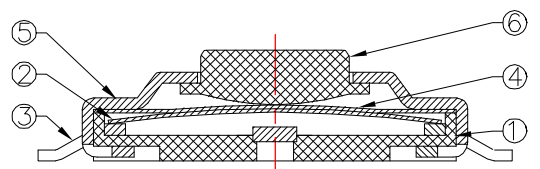
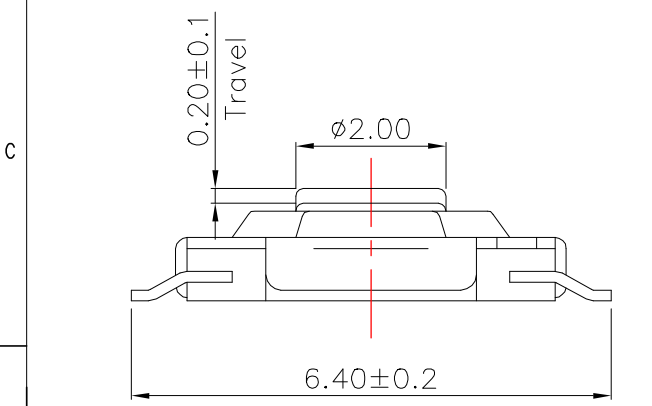

Typical Specifications :  
 1. Rating : DC 12V 50mA  
 2. Life:100,000 Cycles Min.

P/N: TS-KG87S-X X XX X  
 A: 不锈钢  
 B: 覆磷铜  
 T: 编带  
 B: 散装  
 G: 150±50gf  
 F: 250±50gf  
 H: 高度

⑥	Knob	—	1	Brass	Yellow	—
⑤	Cover	—	1	SUS	Natural	—
④	Dust Cover	—	1	Kapton Film	Yellow	—
③	Terminal	—	4	Phosphor Bronze	Plating silver	—
②	Contact	—	1	F.Ag/SUS	Natural	—
①	Base	—	1	Nylon	Black	—
ITEM	PART NAME	ER'NO.	QTY.	MATERIAL	FINISHING	REMAP

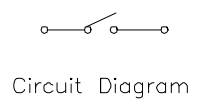
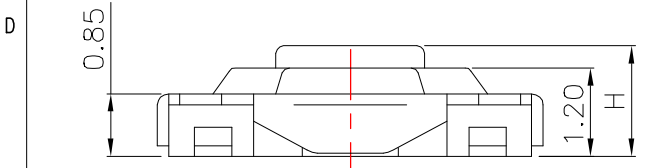

UNLESS OTHERWISE SPECIFIED TOLERANCES

DFCIMALS: 30~以上±0.30  
 10~30±0.20  
 5~10±0.15  
 ~5±0.10

ANGLFS: ±2°

**东莞市汉博电子科技有限公司**  
 DONGGUAN HANBO TECHNOLOGY CO., LTD

TITLE: TACT SWITCH

DWN	xiong	PART NO.	TS-KG87S-XXXXX
CHKD	lee	SCALE: 1:1	UNIT: mm
APVD	wang	SIZE: A4	SHEET: 10F 1
REV:	A4	CUSTOMER COPY	