

4

3

2

1

THIS DRAWING IS UNPUBLISHED. RELEASED FOR PUBLICATION 20
 © COPYRIGHT 20 BY TYCO ELECTRONICS CORPORATION. ALL RIGHTS RESERVED.

LOC	DIST	REVISIONS			
P	LTR	DESCRIPTION	DATE	DWN	APVD
		A	ECO-07-029018 / ECR-07-029589	11DEC2007	DS AT
		A1	ECO-20-008652	22JUN2020	CN AC

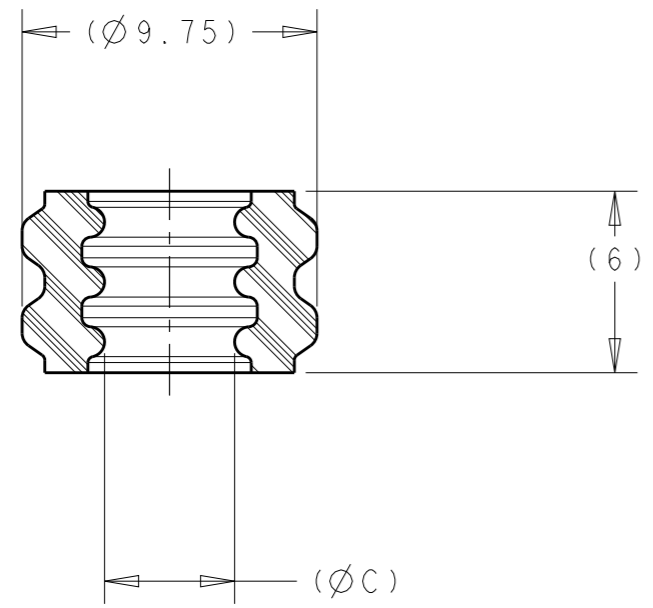
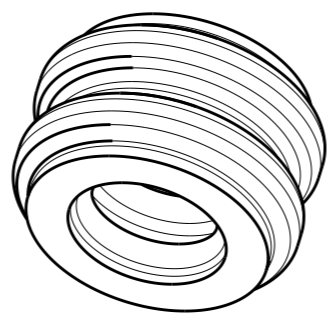
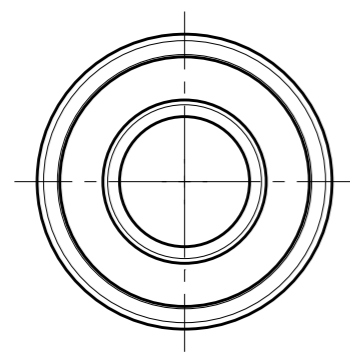

SECTION A - A

- MATERIAL:
 TYPE: INHERENTLY LUBRICATED SILICONE
 COLOR: SEE CHART
 DUROMETER: SEE CHART
- PART DIMENSIONS SHOWN ARE IN FREE STATE CONDITION
- FEATURES DENOTED BY REFERENCE DIMENSIONS MUST BE INSPECTED FOR PRESENCE
- PART MUST BE FREE OF EXCESSIVE FLASH, MIS-MATCH, STAINS, SCORES, SINK MARKS, OR OTHER VISUAL IMPERFECTIONS THAT MAY AFFECT PRODUCT FIT OR FUNCTION

△ 5 REMOVED

BLUE	30	3.60	CABLE SEAL, HVA	1587530-3
GREEN	50	5.20	CABLE SEAL, SIZE C-D, HVA	1587530-2
YELLOW	30	4.30	CABLE SEAL, SIZE A-B, HVA	1587530-1
COLOR	DUROMETER	ØC	DESCRIPTION	PART NO

<small>THIS DRAWING IS A CONTROLLED DOCUMENT FOR TYCO ELECTRONICS CORPORATION. IT IS SUBJECT TO CHANGE AND THE CONTROLLING ENGINEERING ORGANIZATION SHOULD BE CONTACTED FOR THE LATEST REVISION.</small>		DWN 26JAN2007 D SIMPSON CHK 11DEC2007 A TYLER APVD - J BOLEWITZ	Tyco Electronics Harrisburg, PA 17105-3608
DIMENSIONS: mm 	TOLERANCES UNLESS OTHERWISE SPECIFIED: 0 PLC ±. 1 PLC ±0.5 2 PLC ±0.13 3 PLC ±0.013 4 PLC ±0.0001 ANGLES ±.	PRODUCT SPEC - APPLICATION SPEC - WEIGHT -	NAME CABLE SEAL, HVA HVA TERMINATION SIZE CAGE CODE DRAWING NO RESTRICTED TO A300779 C-1587530
MATERIAL NOTED	FINISH -	CUSTOMER DRAWING	SCALE 4:1 SHEET 1 OF 1 REV A1

Mouser Electronics

Authorized Distributor

Click to View Pricing, Inventory, Delivery & Lifecycle Information:

[TE Connectivity:](#)

[1587530-2](#)