

SPECIFICATION FOR APPROVAL

CUSTOMER : _____

PRODUCT TYPE : SMD TCXO 2.5 * 2.0

NOMINAL FREQ. : 26 MHz

TXC P/N : 7L26072002

REVISION : S1

CUSTOMER P/N : _____

PM / SALES : _____

DATE : _____

CUSTOMER SIGNATURE & DATE
: _____

- (1) TXC requires one copy returned with signature and title of authorized individual that signifies acceptance of the attached specifications.
- (2) Orders received and accepted by TXC after return of signed copy of specification will be produced per these specifications.
- (3) Any changes to these specifications must be agreed upon by both parties and new revision of the Product Specification Sheet will be issued.
- (4) Any issuance of purchase order prior to consigning back the Approval page of "Specification Sheets" from customers will be regarded as the agreement on the contents of these specifications.

Attachment(s):

- 1. Product Specification Sheet
- 2. Testing Report(Electrical & Temperature)
- 3. Reliability Report

RoHS Compliant

PRODUCT SPECIFICATION SHEET

CUSTOMER : _____

PRODUCT TYPE : SMD TCXO 2.5 * 2.0

NOMINAL FREQ. : 26 MHz

TXC P/N : 7L26072002

REVISION : S1

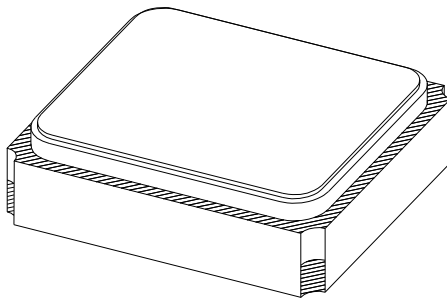

PE/RD	QA	MFG
<i>Kenneth Kao</i>		
2012/11/20		

NOTE:

- (1) Lead Free Products are " Directive 2002 / 95 / EC of The European Parliament of 27 January 2003 on the restriction of the use of certain hazardous substances (RoHS) in electrical and electronic equipment" Compliant (Attachment: SGS Test Report).
- (2) Revision "Sx" is for engineering samples only. PE/RD's approval required.
- (3) Revision "Ax" is production ready. PE, QA and MFG's approval required.

RoHS Compliant

PRODUCT TYPE : SMD TCXO 2.5 * 2.0

P/N : 7L26072002

REVISION : S1

<u>Rev</u>	<u>Revise page</u>	<u>Revise contents</u>	<u>Date</u>	<u>Ref.No.</u>	<u>Reviser</u>
S1	N/A	Initial released	2012/11/20	N/A	Su-Chen Chiang

PRODUCT TYPE : SMD TCXO 2.5 * 2.0

P/N : 7L26072002

REVISION : S1

■ ELECTRICAL SPECIFICATIONS

Item	Parameters		Condition	Electrical Specifications				Note
				MIN	TYP	MAX	UNITS	
1	Nominal Frequency			26.000000			MHz	
2	Operating Temperature Range			-30		+85	°C	
3	Supply Voltage			1.70	1.80	1.90	V	
4	Current Drain		With standard output load			1.5	mA	
5	Output Level(Vp-p)			0.8			V	1
6	Output Type			Clipped Sinewave				
7	Output Load		Resistance	9	10	11	kΩ	
8			Capacitance	9	10	11	pF	
9	Frequency Tolerance		After 2 times reflow			±1.5	ppm	2
10	Frequency Stability	vs. Temperature	Temp: -30 ~ +85 °C			±2.5	ppm	3
11		vs. Load	± 10% output load			±0.2	ppm	
12		vs. Supply Voltage	Vcc: 1.8 V ±0.1 V			±0.2	ppm	
13	Auto-Frequency-Control(AFC)		Vcont = 1.5 V	+9		+15	ppm	
14	Range (Ref : Vcon=0.9 V)		Vcont = 0.3 V	-15		-9	ppm	
15	Input Impedance for AFC pin			500			kΩ	
16	AFC Linearity					±20	%	
17	Storage Temperature			-40		+85	°C	
18	Start-up Time	vs. Frequency	Within ± 1 ppm			2.0	ms	
19		vs. Output Level	To 90% of Vp-p			2.0	ms	
20	Duty Cycle			45	50	55	%	
21	Aging					±1.0	ppm/year	
22	Harmonics					-5	dBc	
23	Phase Noise	@ 1 kHz offset			-130		dBc/Hz	
24		@ 10 kHz offset			-140		dBc/Hz	
25		@ 100 kHz offset			-150		dBc/Hz	
26		@ 1 MHz offset			-152		dBc/Hz	

Note 1 Decoupling capacitor is required in external circuit

Note 2 Refer to nominal frequency

Note 3 Refer to frequency at 25±2°C

TESTING CIRCUIT

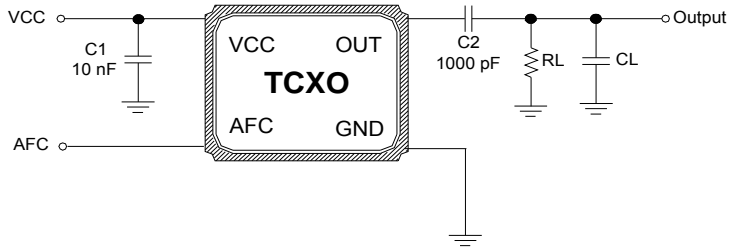

External Components

Name	Function
C1	AC Noise Bypass for VCC
C2	DC Block for Output
RL	Load Resistance
CL	Load Capacitance

Note: Bypass capacitor (C1) and DC blocking capacitor (C2) should be placed.

DIMENSIONS

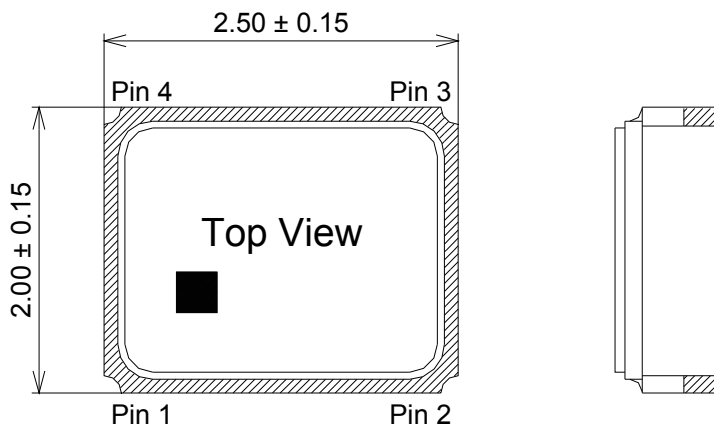

Pin Connection

Name	Function
Pin 1	AFC
Pin 2	GND
Pin 3	OUTPUT
Pin 4	VCC

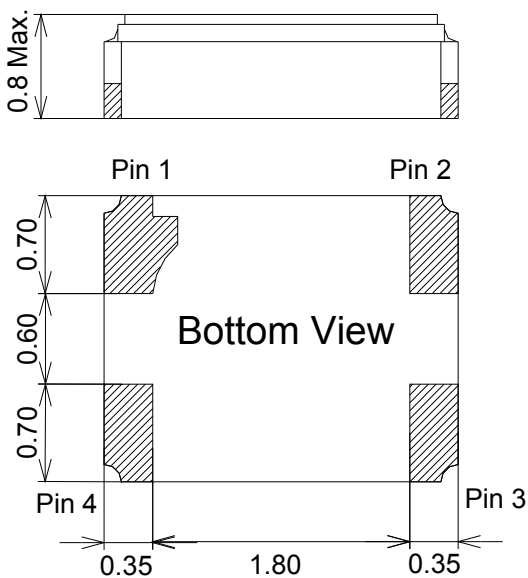

Unit: mm

Recommended Land Pattern

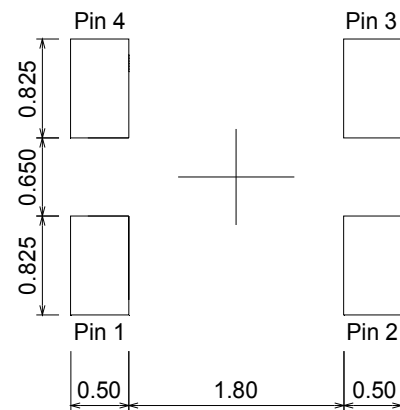

■ SUGGESTED REFLOW PROFILE

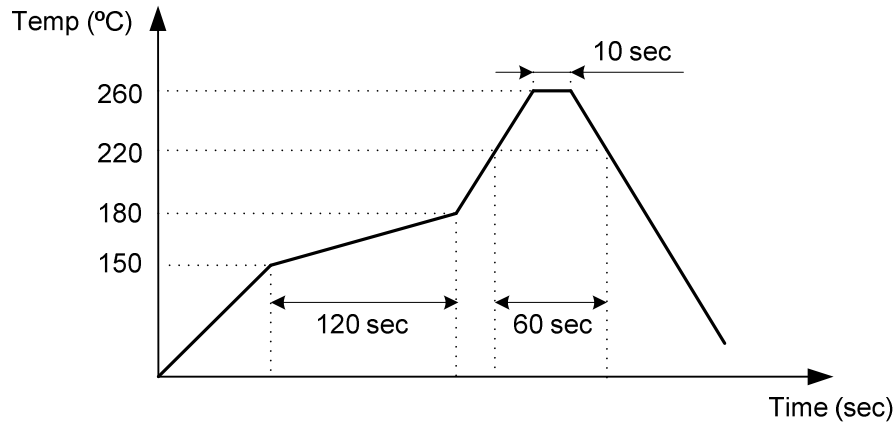

Note : Total Time: 200 sec. Max., Solder Melting Point: 220°C

■ MARKING

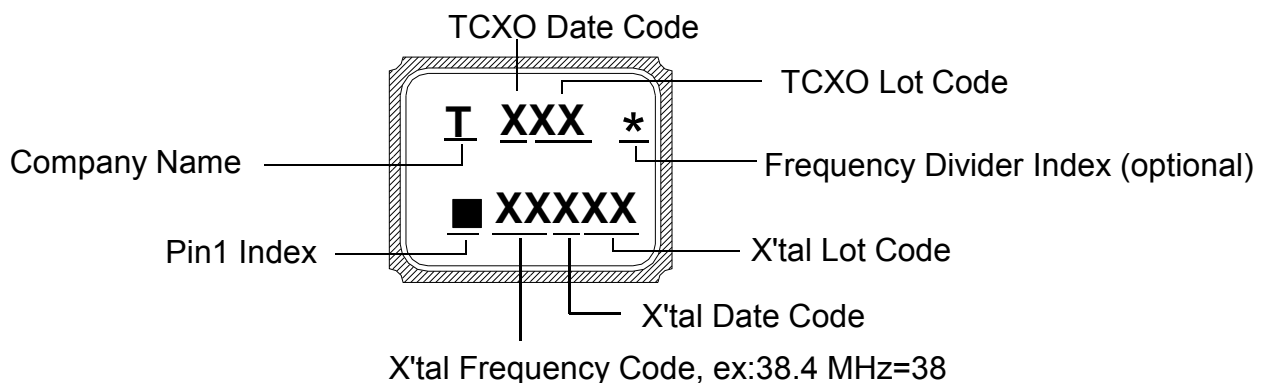

DATE CODE

				MONTH											
YEAR				JAN	FEB	MAR	APR	MAY	JUN	JUL	AUG	SEP	OCT	NOV	DEC
2005	2009	2013	2017	A	B	C	D	E	F	G	H	J	K	L	M
2006	2010	2014	2018	N	P	Q	R	S	T	U	V	W	X	Y	Z
2007	2011	2015	2019	a	b	c	d	e	f	g	h	j	k	l	m
2008	2012	2016	2020	n	p	q	r	s	t	u	v	w	x	y	z

* This date code will be cycled every four years.

Note: If TCXO frequency is X'tal frequency divided by 2, then frequency divider index appears.
 If TCXO frequency is the same as X'tal frequency, then no frequency divider index appears.

■ PACKING : (EIA-481-2)

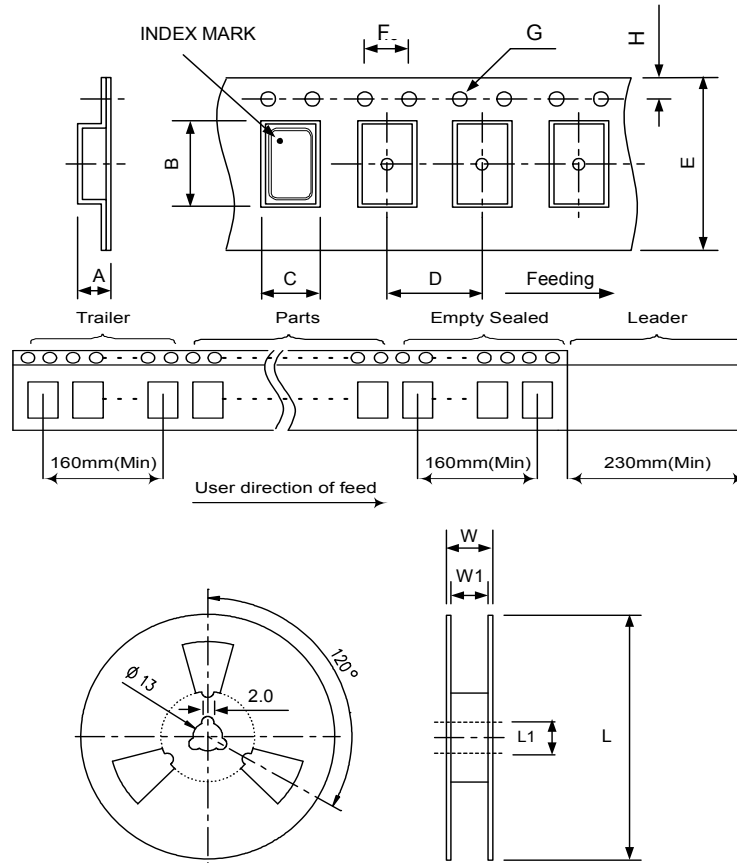

Unit: mm

DIMENSIONS (mm)	A	B	C	D	E	F	G	H	L	L1	W	W1	Standard Reel Quantity is 3,000 pcs per reel
	1.15	2.70	2.25	4.00	8.00	4.00	1.55	1.75	178	13.0	11.6	8.4	

■ WEIGHT

0.0135 g / piece(TYP), 40 ± 2 g / 3 kpcs(regardless of tape weight)

■ **STRUCTURE ILLUSTRATION**

Crystal Enclosure Seal: Seam Welding

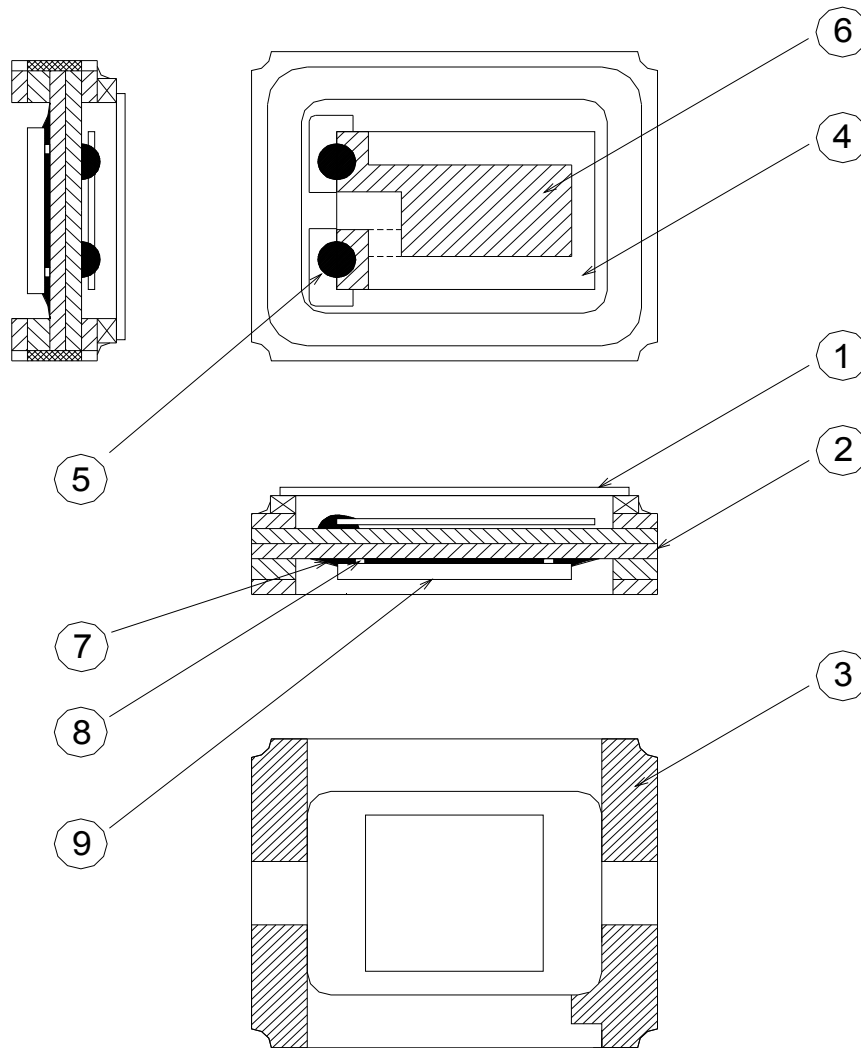

No.	COMPONENTS	MATERIALS	FINISH/SPECIFICATIONS
1	Cap	Metal(Fe + Co + Ni)	-
2	Base	Ceramic	Color Black
3	Pad	Au	Tungsten Metalize + Ni Plating + Au Plating
4	Crystal Blank	SiO ₂	-
5	Conductive Adhesive	Ag	Silicone Resin
6	Electrode	Noble Metal	-
7	Underfill	Organic	Color Black
8	Bump	Au	
9	IC	Si	

■ RELIABILITY SPECIFICATIONS

1. Mechanical Endurance

No.	Test Item	Test Methods	Criteria
1.1	Drop Test	Height : 100 cm height Direction : X,Y,Z 6 directions Test cycles : 3 cycles Fall freely on to concrete floor Mounting on test fixture (total weight=100 g)	+/- 2.0 ppm
1.2	Mechanical Shock	Acceleration : 1000 g Duration : 0.5 ms Test cycles : 3 times for all 3 directions	+/- 2.0 ppm
1.3	Vibration	Frequency range : 10 ~ 2000 Hz Amplitude : 1.52 mm (10 ~ 80 Hz) Acceleration : 20 g (80 ~ 2000 Hz) Sweep speed : 20 minutes/cycle Direction : X,Y,Z 3 directions Duration : 4 hours/each direction	+/- 2.0 ppm
1.4	Gross Leak	Standard sample for automatic gross leak detector. Test Pressure : 2 kg/cm ²	< 1.5 × 10 ⁻⁵ Pa m ³ / sec
1.5	Fine Leak	Helium bombing 4.5 kgf/cm ² for 2 hours	< 1.0 × 10 ⁻⁹ Pa m ³ / sec
1.6	Solderability	Preheate temperature : 125°C ± 5°C Preheate time : 120 sec Soldering temperature : 245°C ± 5 °C Duration : 5 ± 1 sec Method : Solder bath method	90% Coated

[Note] Criteria mean the maximum frequency change after reliability test, frequency shall be measured at 25°C.

2. Environmental Endurance

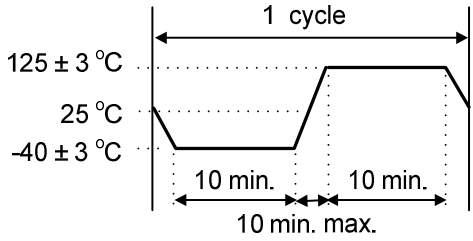
No.	Test Item	Test Methods	Criteria
2.1	High Temp. Storage	Temperature : +125°C ± 3°C Duration : 168 hours	+/- 2.0 ppm
2.2	Low Temp. Storage	Temperature : -40°C ± 3°C Duration : 500 hours	+/- 2.0 ppm
2.3	Thermal Shock (Air to Air)	Total 100 cycles of the following temperature cycle : 	+/- 2.0 ppm
2.4	High Temp & Humidity	Temperature : 85°C ± 3°C Humidity: RH 85% Duration : 168 hours	+/- 2.0 ppm
2.5	Aging	Temperature : 85°C ± 3°C Duration : 500 hours Voltage input by specification	+/- 2.0 ppm

[Note] Criteria mean the maximum frequency change after reliability test, frequency shall be measured after 2 hours at 25°C leaving.