



General Description

The MD70XX series is a set of three-terminal low power voltage detectors implemented in CMOS technology. Each voltage detector in the series detects a particular fixed voltage ranging from 1.2V to 7V. The voltage detectors consist of a high-precision and low power consumption standard voltage source, a comparator, hysteresis circuit, and an output driver. CMOS technology ensures low power consumption. Although designed primarily as fixed voltage detectors, these devices can be used with external components to detect user specified threshold voltages

Features

- Low power consumption
- Low temperature coefficient
- Built-in high-stability reference source
- Open drain types:
 - NMOS: MD70XX
 - CMOS: 70XXC
- Built-in hysteresis characteristic
- TO-92 package
- SOT-89 package
- SOT-23-3/5 package
- SSOT-24 package

Applications

- Battery checkers
- Level selectors
- Power failure detectors
- Microcomputer reset
- Battery memory backup
- Non-volatile RAM signal storage protectors

Absolute Maximum Ratings

Supply Voltage..... -0.3V to 18V
Output Voltage $V_{SS}-0.3V$ to $V_{DD}+0.3V$
Storage Temperature..... $-50^{\circ}C$ to $125^{\circ}C$
Operating Temperature..... $-40^{\circ}C$ to $85^{\circ}C$
Output Current..... 10mA

Power Consumption:
SOT89-3 500mW
TO-92 300mW
SOT23-/5 250mW

Note: These are stress ratings only. Stresses exceeding the range specified under Absolute Maximum Ratings may cause substantial damage to the device. Functional operation of this device at other conditions beyond those listed in the specification is not implied and prolonged exposure to extreme conditions may affect device reliability.

Selection Table

Part No.	Detectable Voltage	Hysteresis Width	Tolerance	Marking		
				TO92/SOT89-3	SOT23-3/5	
MD7015	1.5V	0.075V	±3%	MD70XX	MD 0XX	NMOS Drain output
MD7019	1.9V	0.095V	±3%			
MD7020	2.0V	0.100V	±3%			
MD7021	2.1V	0.105V	±3%			
MD7022	2.2V	0.110V	±3%			
MD7023	2.3V	0.115V	±3%			
MD7024	2.4V	0.120V	±3%			
MD7027	2.7V	0.135V	±3%			
MD7030	3.0V	0.150V	±3%			
MD7033	3.3V	0.165V	±3%			
MD7035	3.5V	0.175V	±3%			
MD7036	3.6V	0.180V	±3%			
MD7039	3.9V	0.195V	±3%			
MD7042	4.2V	0.210V	±3%			
MD7043	4.3V	0.215V	±3%			
MD7044	4.4V	0.220V	±3%			
MD7047	4.7V	0.235V	±3%			
MD7050	5.0V	0.250V	±3%			
MD7070	7.0V	0.350V	±3%	MD70XXC	70XXC	CMOS output
MD7025C	2.5V	0.125V	±3%			
MD7027C	2.7V	0.135V	±3%			
MD7030C	3.0V	0.150V	±3%			
MD7033C	3.3V	0.165V	±3%			

For example: The MD7044 is a 4.4V, NMOS open drain active low output

For semi-custom parts,selectable regulated voltage range is from 1.2V to 12V in 0.1V increment.

For semi-custom parts,selectable output type CMOS .

Block Diagram

N channel open drain output (normal open; active low)

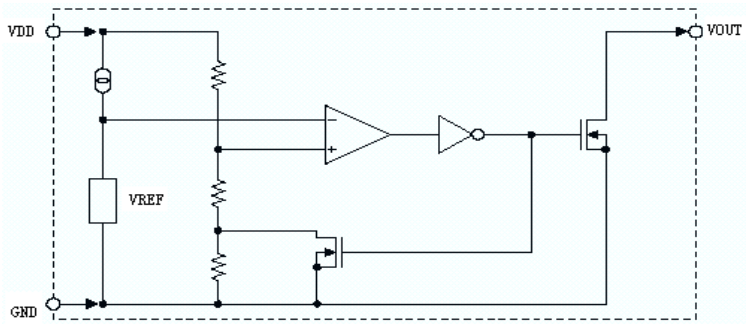

CMOS output (normal high; active low)

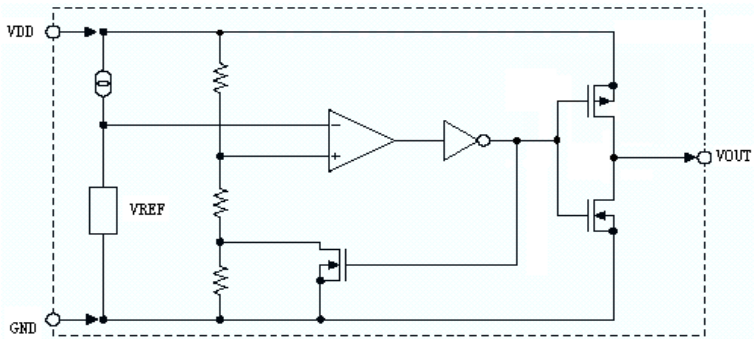

Logical Characteristic(NMOS/CMOS TYPE)

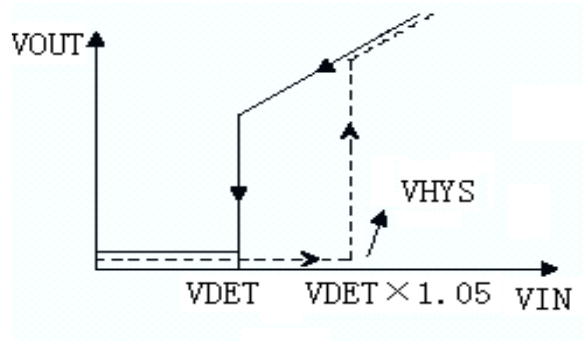

- (1) Solid Line V_{IN} from Hi→Lo
- (2) Dash Line V_{IN} from Lo→Hi

Pin Assignment

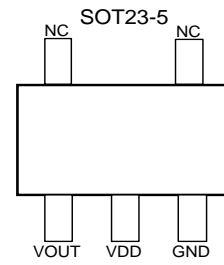
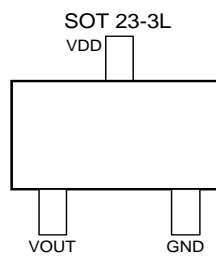
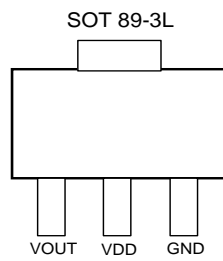
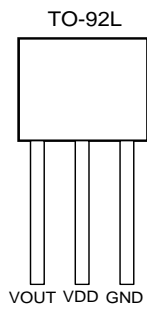

Electrical Characteristic

MD7015

T_A=25°C

Symbol	Parameter	Test Conditions		Min.	Typ.	Max.	Unit
		V _{DD}	Conditions				
V _{DET}	Hi→Lo Detectable Voltage	--	--	1.455	1.5	1.545	V
V _{HYS}	Hysteresis Width	--	--	0.02 V _{DET}	0.05 V _{DET}	0.07 V _{DET}	V
I _{DD}	Operating Current	2.5	No load	--	1.2	3	μA
V _{DD}	Operating Voltage	--	--	1.0	--	15	V
I _{OL}	Output Sink Current	1.4	V _{OUT} =0.2V	1	1.5	--	mA
$\frac{\Delta V_{DET}}{\Delta T_A}$	Temperature Coefficient	--	0°C<T _a <70°C	--	±0.4	--	mV/°C

MD7019

T_A=25°C

Symbol	Parameter	Test Conditions		Min.	Typ.	Max.	Unit
		V _{DD}	Conditions				
V _{DET}	Hi→Lo Detectable Voltage	--	--	1.843	1.9	1.957	V
V _{HYS}	Hysteresis Width	--	--	0.02 V _{DET}	0.05 V _{DET}	0.07 V _{DET}	V
I _{DD}	Operating Current	2.9	No load	--	1.2	3	μA
V _{DD}	Operating Voltage	--	--	1.5	--	15	V
I _{OL}	Output Sink Current	1.8	V _{OUT} =0.2V	1	2	--	mA
$\frac{\Delta V_{DET}}{\Delta T_A}$	Temperature Coefficient	--	0°C<T _a <70°C	--	±0.5	--	mV/°C

MD7020

T_A=25°C

Symbol	Parameter	Test Conditions		Min.	Typ.	Max.	Unit
		V _{DD}	Conditions				
V _{DET}	Hi→Lo Detectable Voltage	--	--	1.94	2.0	2.06	V
V _{HYS}	Hysteresis Width	--	--	0.02 V _{DET}	0.05 V _{DET}	0.07 V _{DET}	V
I _{DD}	Operating Current	3.0	No load	--	1.2	3	μA
V _{DD}	Operating Voltage	--	--	1.5	--	15	V
I _{OL}	Output Sink Current	1.9	V _{OUT} =0.2V	1	2	--	mA
$\frac{\Delta V_{DET}}{\Delta T_A}$	Temperature Coefficient	--	0°C<T _a <70°C	--	±0.5	--	mV/°C

MD7021

T_A=25°C

Symbol	Parameter	Test Conditions		Min.	Typ.	Max.	Unit
		V _{DD}	Conditions				
V _{DET}	Hi→Lo Detectable Voltage	--	--	2.037	2.1	2.163	V
V _{HYS}	Hysteresis Width	--	--	0.02 V _{DET}	0.05 V _{DET}	0.07 V _{DET}	V
I _{DD}	Operating Current	3.1	No load	--	1.2	3	μA
V _{DD}	Operating Voltage	--	--	1.5	--	15	V
I _{OL}	Output Sink Current	2.0	V _{OUT} =0.2V	1	2	--	mA
$\frac{\Delta V_{DET}}{\Delta T_A}$	Temperature Coefficient	--	0°C<T _a <70°C	--	±0.5	--	mV/°C

Low Voltage Detector

MD70XX SERIES

(NMOS/CMOS)

MD7022

T_A=25°C

Symbol	Parameter	Test Conditions		Min.	Typ.	Max.	Unit
		V _{DD}	Conditions				
V _{DET}	Hi→Lo Detectable Voltage	--	--	2.134	2.2	2.266	V
V _{HYS}	Hysteresis Width	--	--	0.02 V _{DET}	0.05 V _{DET}	0.07 V _{DET}	V
I _{DD}	Operating Current	3.2	No load	--	1.2	3	μA
V _{DD}	Operating Voltage	--	--	1.5	--	15	V
I _{OL}	Output Sink Current	2	V _{OUT} =0.2V	1.5	3	--	mA
$\frac{\Delta V_{DET}}{\Delta T_A}$	Temperature Coefficient	--	0°C<T _a <70°C	--	±0.5	--	mV/°C

MD7023

T_A=25°C

Symbol	Parameter	Test Conditions		Min.	Typ.	Max.	Unit
		V _{DD}	Conditions				
V _{DET}	Hi→Lo Detectable Voltage	--	--	2.231	2.3	2.369	V
V _{HYS}	Hysteresis Width	--	--	0.02 V _{DET}	0.05 V _{DET}	0.07 V _{DET}	V
I _{DD}	Operating Current	3.3	No load	--	1.2	3	μA
V _{DD}	Operating Voltage	--	--	1.5	--	15	V
I _{OL}	Output Sink Current	2.1	V _{OUT} =0.2V	1	3	--	mA
$\frac{\Delta V_{DET}}{\Delta T_A}$	Temperature Coefficient	--	0°C<T _a <70°C	--	±0.5	--	mV/°C

MD7024

T_A=25°C

Symbol	Parameter	Test Conditions		Min.	Typ.	Max.	Unit
		V _{DD}	Conditions				
V _{DET}	Hi→Lo Detectable Voltage	--	--	2.328	2.4	2.472	V
V _{HYS}	Hysteresis Width	--	--	0.02 V _{DET}	0.05 V _{DET}	0.07 V _{DET}	V
I _{DD}	Operating Current	3.4	No load	--	1.2	3	μA
V _{DD}	Operating Voltage	--	--	1.5	--	15	V
I _{OL}	Output Sink Current	2.2	V _{OUT} =0.2V	1.5	3	--	mA
$\frac{\Delta V_{DET}}{\Delta T_A}$	Temperature Coefficient	--	0°C<T _a <70°C	--	±0.5	--	mV/°C

MD7025

T_A=25°C

Symbol	Parameter	Test Conditions		Min.	Typ.	Max.	Unit
		V _{DD}	Conditions				
V _{DET}	Hi→Lo Detectable Voltage	--	--	2.425	2.5	2.575	V
V _{HYS}	Hysteresis Width	--	--	0.02 V _{DET}	0.05 V _{DET}	0.07 V _{DET}	V
I _{DD}	Operating Current	3.5	No load	--	1.2	3	μA
V _{DD}	Operating Voltage	--	--	1.5	--	15	V
I _{OL}	Output Sink Current	2.3	V _{OUT} =0.2V	1.5	3	--	mA
$\frac{\Delta V_{DET}}{\Delta T_A}$	Temperature Coefficient	--	0°C<T _a <70°C	--	±0.5	--	mV/°C

Low Voltage Detector

MD70XX SERIES

(NMOS/CMOS)

MD7027

T_A=25°C

Symbol	Parameter	Test Conditions		Min.	Typ.	Max.	Unit
		V _{DD}	Conditions				
V _{DET}	Hi→Lo Detectable Voltage	--	--	2.619	2.7	2.781	V
V _{HYS}	Hysteresis Width	--	--	0.02 V _{DET}	0.05 V _{DET}	0.07 V _{DET}	V
I _{DD}	Operating Current	3.7	No load	--	1.2	3	uA
V _{DD}	Operating Voltage	--	--	1.5	--	15	V
I _{OL}	Output Sink Current	2.5	V _{OUT} =0.2V	2	4	--	mA
$\frac{\Delta V_{DET}}{\Delta T_A}$	Temperature Coefficient	--	0°C<T _a <70°C	--	±0.5	--	mV/°C

MD7030

T_A=25°C

Symbol	Parameter	Test Conditions		Min.	Typ.	Max.	Unit
		V _{DD}	Conditions				
V _{DET}	Hi→Lo Detectable Voltage	--	--	2.91	3.0	3.09	V
V _{HYS}	Hysteresis Width	--	--	0.02 V _{DET}	0.05 V _{DET}	0.07 V _{DET}	V
I _{DD}	Operating Current	4.0	No load	--	1.2	3	uA
V _{DD}	Operating Voltage	--	--	1.5	--	15	V
I _{OL}	Output Sink Current	2.7	V _{OUT} =0.2V	2	4	--	mA
$\frac{\Delta V_{DET}}{\Delta T_A}$	Temperature Coefficient	--	0°C<T _a <70°C	--	±0.5	--	mV/°C

MD7033

T_A=25°C

Symbol	Parameter	Test Conditions		Min.	Typ.	Max.	Unit
		V _{DD}	Conditions				
V _{DET}	Hi→Lo Detectable Voltage	--	--	3.201	3.3	3.399	V
V _{HYS}	Hysteresis Width	--	--	0.02 V _{DET}	0.05 V _{DET}	0.07 V _{DET}	V
I _{DD}	Operating Current	4.3	No load	--	1.2	3	uA
V _{DD}	Operating Voltage	--	--	1.5	--	15	V
I _{OL}	Output Sink Current	3.1	V _{OUT} =0.2V	2	4	--	mA
$\frac{\Delta V_{DET}}{\Delta T_A}$	Temperature Coefficient	--	0°C<T _a <70°C	--	±0.5	--	mV/°C

MD7035

T_A=25°C

Symbol	Parameter	Test Conditions		Min.	Typ.	Max.	Unit
		V _{DD}	Conditions				
V _{DET}	Hi→Lo Detectable Voltage	--	--	3.395	3.5	3.605	V
V _{HYS}	Hysteresis Width	--	--	0.02 V _{DET}	0.05 V _{DET}	0.07 V _{DET}	V
I _{DD}	Operating Current	4.5	No load	--	1.2	3	uA
V _{DD}	Operating Voltage	--	--	1.5	--	15	V
I _{OL}	Output Sink Current	3.2	V _{OUT} =0.2V	2	4	--	mA
$\frac{\Delta V_{DET}}{\Delta T_A}$	Temperature Coefficient	--	0°C<T _a <70°C	--	±0.5	--	mV/°C

MD7036

T_A=25°C

Symbol	Parameter	Test Conditions		Min.	Typ.	Max.	Unit
		V _{DD}	Conditions				
V _{DET}	Hi→Lo Detectable Voltage	--	--	3.492	3.6	3.708	V
V _{HYS}	Hysteresis Width	--	--	0.02 V _{DET}	0.05 V _{DET}	0.07 V _{DET}	V
I _{DD}	Operating Current	4.6	No load	--	1.2	3	μA
V _{DD}	Operating Voltage	--	--	1.5	--	15	V
I _{OL}	Output Sink Current	3.4	V _{OUT} =0.2V	3	6	--	mA
$\frac{\Delta V_{DET}}{\Delta T_A}$	Temperature Coefficient	--	0°C<T _a <70°C	--	±0.5	--	mV/°C

MD7039

T_A=25°C

Symbol	Parameter	Test Conditions		Min.	Typ.	Max.	Unit
		V _{DD}	Conditions				
V _{DET}	Hi→Lo Detectable Voltage	--	--	3.783	3.9	4.017	V
V _{HYS}	Hysteresis Width	--	--	0.02 V _{DET}	0.05 V _{DET}	0.07 V _{DET}	V
I _{DD}	Operating Current	4.9	No load	--	.22	3	μA
V _{DD}	Operating Voltage	--	--	1.5	--	15	V
I _{OL}	Output Sink Current	3.7	V _{OUT} =0.2V	3	6	--	mA
$\frac{\Delta V_{DET}}{\Delta T_A}$	Temperature Coefficient	--	0°C<T _a <70°C	--	±0.5	--	mV/°C

MD7042

T_A=25°C

Symbol	Parameter	Test Conditions		Min.	Typ.	Max.	Unit
		V _{DD}	Conditions				
V _{DET}	Hi→Lo Detectable Voltage	--	--	4.074	4.2	4.326	V
V _{HYS}	Hysteresis Width	--	--	0.02 V _{DET}	0.05 V _{DET}	0.07 V _{DET}	V
I _{DD}	Operating Current	5.2	No load	--	1.2	3	μA
V _{DD}	Operating Voltage	--	--	1.5	--	15	V
I _{OL}	Output Sink Current	3.8	V _{OUT} =0.2V	3	6	--	mA
$\frac{\Delta V_{DET}}{\Delta T_A}$	Temperature Coefficient	--	0°C<T _a <70°C	--	±0.6	--	mV/°C

MD7043

T_A=25°C

Symbol	Parameter	Test Conditions		Min.	Typ.	Max.	Unit
		V _{DD}	Conditions				
V _{DET}	Hi→Lo Detectable Voltage	--	--	4.171	4.3	4.429	V
V _{HYS}	Hysteresis Width	--	--	0.02 V _{DET}	0.05 V _{DET}	0.07 V _{DET}	V
I _{DD}	Operating Current	5.3	No load	--	1.2	3	μA
V _{DD}	Operating Voltage	--	--	1.5	--	15	V
I _{OL}	Output Sink Current	4.0	V _{OUT} =0.2V	4	8	--	mA
$\frac{\Delta V_{DET}}{\Delta T_A}$	Temperature Coefficient	--	0°C<T _a <70°C	--	±0.6	--	mV/°C

Low Voltage Detector

MD70XX SERIES

(NMOS/CMOS)

MD7044

T_A=25°C

Symbol	Parameter	Test Conditions		Min.	Typ.	Max.	Unit
		V _{DD}	Conditions				
V _{DET}	Hi→Lo Detectable Voltage	--	--	4.268	4.4	4.532	V
V _{HYS}	Hysteresis Width	--	--	0.02 V _{DET}	0.05 V _{DET}	0.07 V _{DET}	V
I _{DD}	Operating Current	5.4	No load	--	1.2	3	μA
V _{DD}	Operating Voltage	--	--	1.5	--	15	V
I _{OL}	Output Sink Current	4.0	V _{OUT} =0.2V	4	8	--	mA
$\frac{\Delta V_{DET}}{\Delta T_A}$	Temperature Coefficient	--	0°C<T _a <70°C	--	±0.6	--	mV/°C

MD7047

T_A=25°C

Symbol	Parameter	Test Conditions		Min.	Typ.	Max.	Unit
		V _{DD}	Conditions				
V _{DET}	Hi→Lo Detectable Voltage	--	--	4.559	4.7	4.841	V
V _{HYS}	Hysteresis Width	--	--	0.02 V _{DET}	0.05 V _{DET}	0.07 V _{DET}	V
I _{DD}	Operating Current	5.7	No load	--	1.2	3	μA
V _{DD}	Operating Voltage	--	--	1.5	--	15	V
I _{OL}	Output Sink Current	4.0	V _{OUT} =0.2V	4	8	--	mA
$\frac{\Delta V_{DET}}{\Delta T_A}$	Temperature Coefficient	--	0°C<T _a <70°C	--	±0.6	--	mV/°C

MD7050

T_A=25°C

Symbol	Parameter	Test Conditions		Min.	Typ.	Max.	Unit
		V _{DD}	Conditions				
V _{DET}	Hi→Lo Detectable Voltage	--	--	4.850	5.0	5.150	V
V _{HYS}	Hysteresis Width	--	--	0.02 V _{DET}	0.05 V _{DET}	0.1 V _{DET}	V
I _{DD}	Operating Current	6.0	No load	--	1.2	3	μA
V _{DD}	Operating Voltage	--	--	1.5	--	15	V
I _{OL}	Output Sink Current	4.8	V _{OUT} =0.2V	4	8	--	mA
$\frac{\Delta V_{DET}}{\Delta T_A}$	Temperature Coefficient	--	0°C<T _a <70°C	--	±0.6	--	mV/°C

MD7070

T_A=25°C

Symbol	Parameter	Test Conditions		Min.	Typ.	Max.	Unit
		V _{DD}	Conditions				
V _{DET}	Hi→Lo Detectable Voltage	--	--	6.790	7.0	7.210	V
V _{HYS}	Hysteresis Width	--	--	0.02 V _{DET}	0.05 V _{DET}	0.07 V _{DET}	V
I _{DD}	Operating Current	8.0	No load	--	1.2	3	μA
V _{DD}	Operating Voltage	--	--	1.0	--	15	V
I _{OL}	Output Sink Current	6.7	V _{OUT} =0.2V	5	8	--	mA
$\frac{\Delta V_{DET}}{\Delta T_A}$	Temperature Coefficient	--	0°C<T _a <70°C	--	±0.8	--	mV/°C

Functional Description

The MD70XX series is a set of voltage detectors equipped with a high stability voltage reference which is connected to the negative input of a comparator—denoted as V_{REF} in the following figure for NMOS output voltage detector.

When the voltage drop to the positive input of the comparator (i.e., V_B) is higher than V_{REF} , V_{OUT} goes high, M1 turns off, and V_B is expressed as $V_{BH} = V_{DD} \times (RB + RC) / (RA + RB + RC)$.

If V_{DD} is decreased so that V_B falls to a value less than V_{REF} , the comparator output inverts from high to low, V_{OUT} goes low, V_C is high, M1 turns on, RC is bypassed, and V_B becomes: $V_{BL} = V_{DD} \times RB / (RA + RB)$, which is less than V_{BH} . By so doing, the comparator output will stay low to prevent the circuit from oscillating when $V_B \approx V_{REF}$.

If V_{DD} falls below the minimum operating voltage, the output becomes undefined. When V_{DD}

goes from low to $V_{DD} \times RB / (RA + RB) > V_{REF}$, the comparator output and V_{OUT} goes high.

The detectable voltage is defined as:

$$V_{DET}(-) = \frac{RA + RB + RC}{RB + RC} \times V_{REF}$$

The release voltage is defined as:

$$V_{DET}(+) = \frac{RA + RB}{RB} \times V_{REF}$$

The hysteresis width is:

$$V_{HYS} = V_{DET}(+) - V_{DET}(-)$$

The figure demonstrates the NMOS output type with positive output polarity (V_{OUT} is normally open, active low). The MD70XX series also supplies options for other output types with active high outputs. Application circuits shown are examples of positive output polarity (normally open, active low) unless otherwise specified.

NMOS output voltage detector

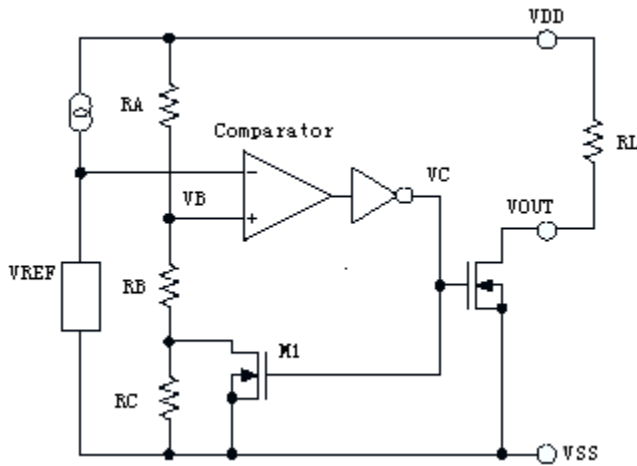

CMOS output voltage detector

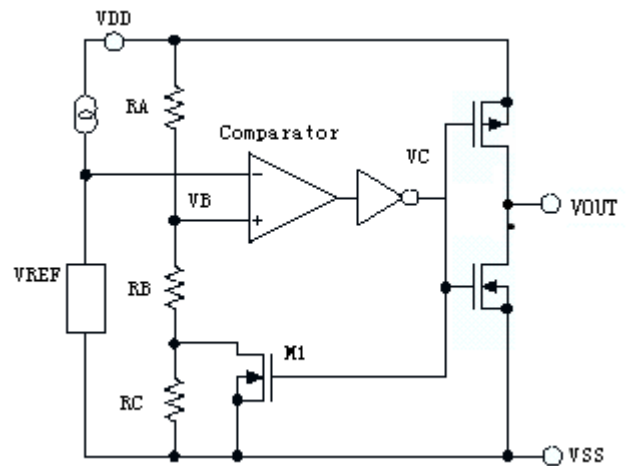

Application Circuits

Microcomputer reset circuit

Normally a reset circuit is required to protect the microcomputer system from malfunctions due to power line interruptions. The following examples show how different output configurations perform a reset function in various systems.

- NMOS open drain output application for separate power supply

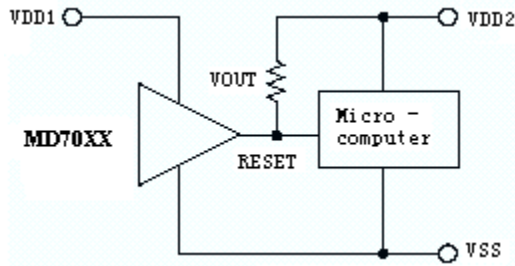

- Power-on reset circuit
With several external components, the NMOS open drain type of the MD70XX series can be used to perform a power-on reset function as shown:

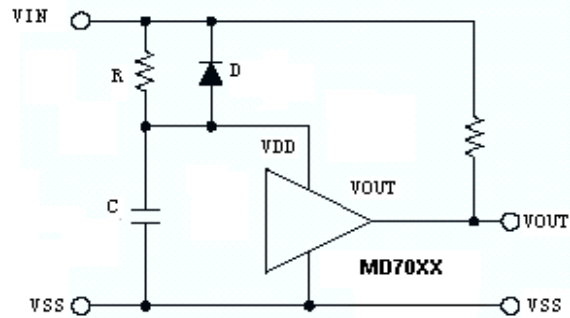

- NMOS open drain output application with R-C delay

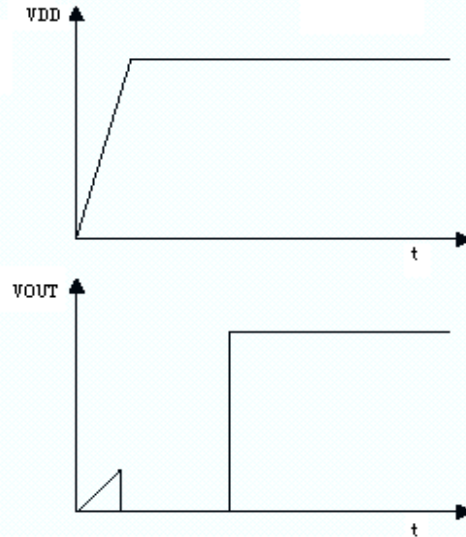
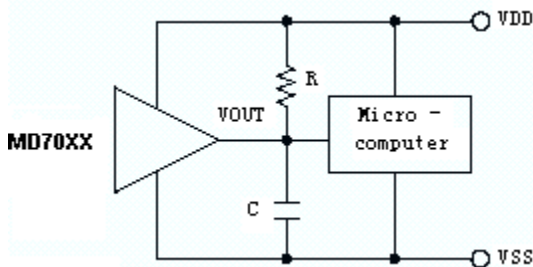

- PMOS open drain output application for separate power supply

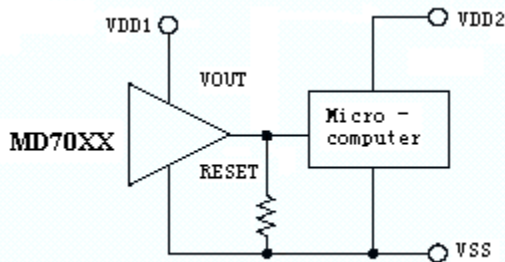

5V power line monitoring circuit

Generally, a minimum operating voltage of 4.5V is guaranteed in a 5V power line system. The MD7044 is recommended for use as 5V power line monitoring circuit.

- 5V power line monitor with power-on reset

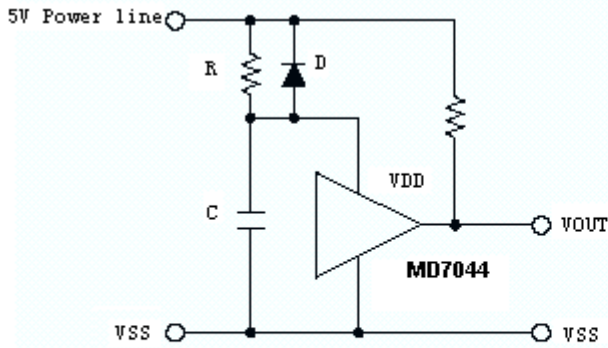

- with 5V voltage regulator

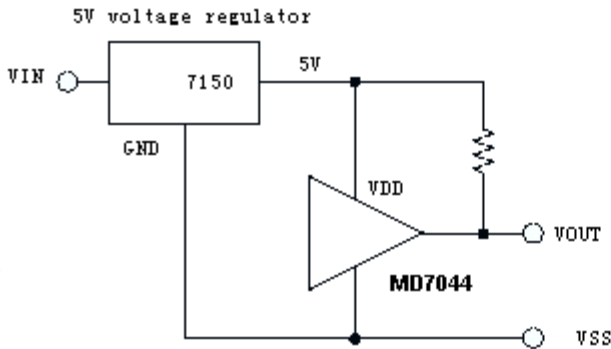

Change of detectable voltage

If the required voltage is not found in the standard product selection table, it is possible to change it by using external resistance dividers or diodes.

- Varying the detectable voltage with a resistance divider

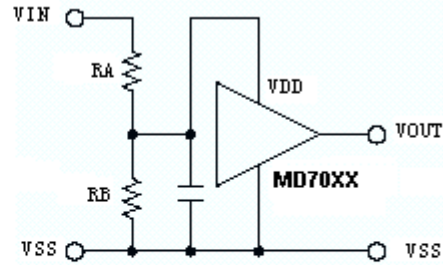

$$\text{Detectable voltage} = \frac{RA + RB}{RB} \times V_{DET}$$

$$\text{Hysteresis width} = \frac{RA + RB}{RB} \times V_{HYS}$$

- Varying the detectable voltage with a diode

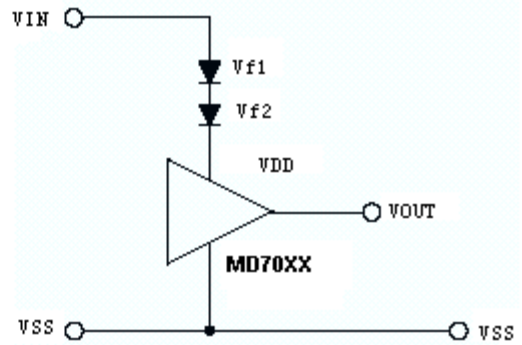

$$\text{Detectable Voltage} = V_{f1} + V_{f2} + V_{DET}$$

Malfunction analysis

The following circuit demonstrates the way a circuit analyzes malfunctions by monitoring the variation or spike noise of power supply voltage.

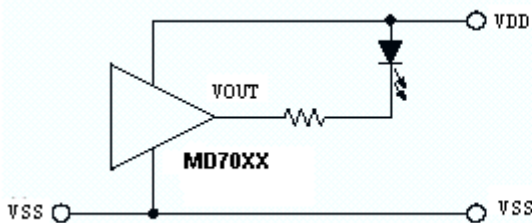

Charge monitoring circuit

The following circuit shows a charged monitor for protection against battery deterioration by overcharging. When the voltage of the battery is higher than the set detectable voltage, the transistor turns on to bypass the charge current, protecting the battery from overcharging.

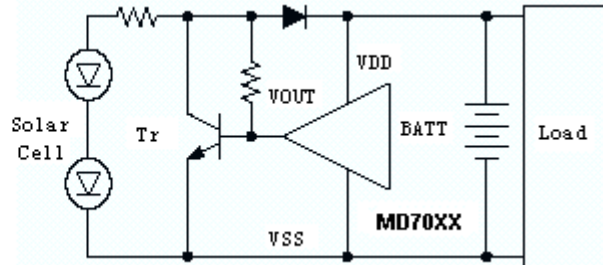

Level selector

The following diagram illustrates a logic level selector.

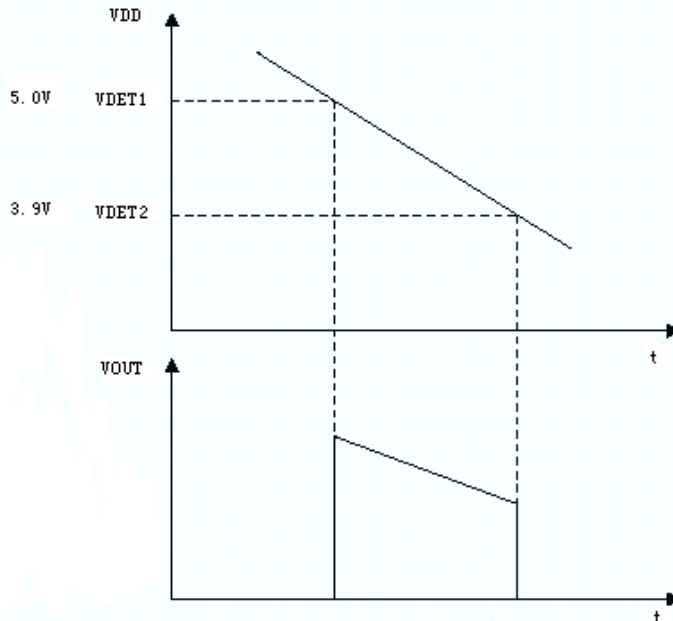
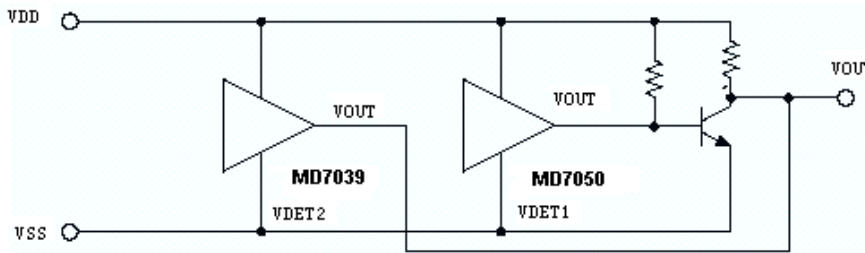

Order Information

MODEL	ORDER NUMBER	PACKAGE DESCRIPTION	PACKAGE OPTION
MD70XX	“XX”express voltage , output default is NMOS Drain Output,,the model is MD70XXC express output type is CMOS,For example MD7033C the detection voltage 3.3V,output type COMS.	SOT89-3	Tape and Reel, 1000
		TO-92	Tape and Bag, 1000
		SOT23-3	Tape and Reel, 3000
		SOT23-5	Tape and Reel, 3000

Package Description

TO92 package outline dimensions

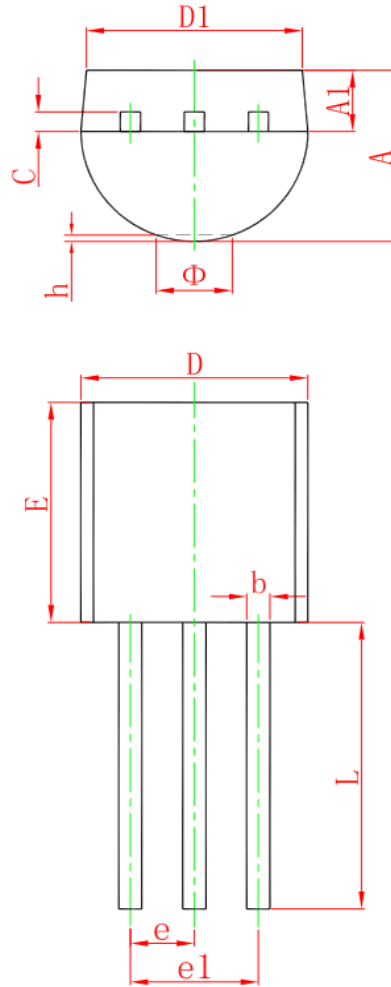

Symbol	Dimensions In Millimeters		Dimensions In Inches	
	Min	Max	Min	Max
A	3.300	3.700	0.130	0.146
A1	1.100	1.400	0.043	0.055
b	0.380	0.550	0.015	0.022
c	0.360	0.510	0.014	0.020
D	4.300	4.700	0.169	0.185
D1	3.430	4.300	0.135	0.169
E	4.300	4.700	0.169	0.185
e	1.270 TYP.		0.050 TYP.	
e1	2.440	2.640	0.096	0.104
L	14.100	14.500	0.555	0.571
Φ		1.600		0.063
h	0.000	0.380	0.000	0.015

SOT89-3L package outline dimensions

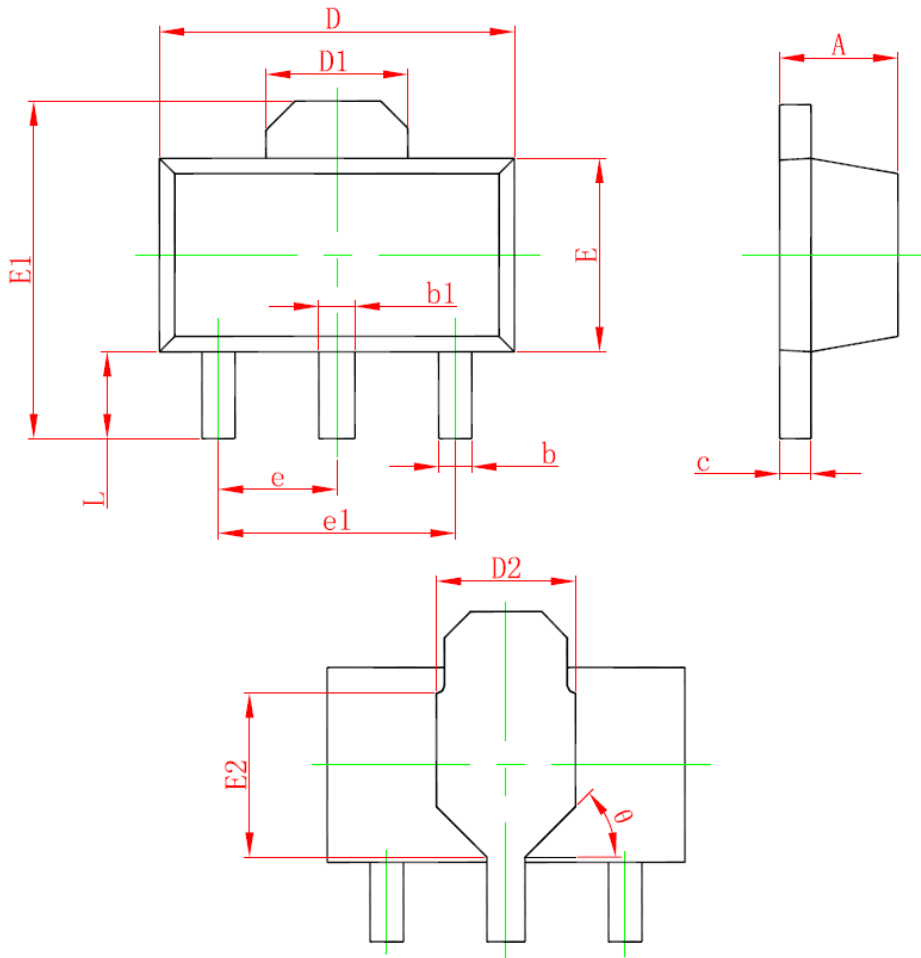

Symbol	Dimensions In Millimeters		Dimensions In Inches	
	Min.	Max.	Min.	Max.
A	1.400	1.600	0.055	0.063
b	0.320	0.520	0.013	0.020
b1	0.400	0.580	0.016	0.023
c	0.350	0.440	0.014	0.017
D	4.400	4.600	0.173	0.181
D1	1.550 REF.		0.061 REF.	
D2	1.750 REF.		0.069 REF.	
E	2.300	2.600	0.091	0.102
E1	3.940	4.250	0.155	0.167
E2	1.900 REF.		0.075 REF.	
e	1.500 TYP.		0.060 TYP.	
e1	3.000 TYP.		0.118 TYP.	
L	0.900	1.200	0.035	0.047
θ	45°		45°	

SOT23-3L package outline dimensions

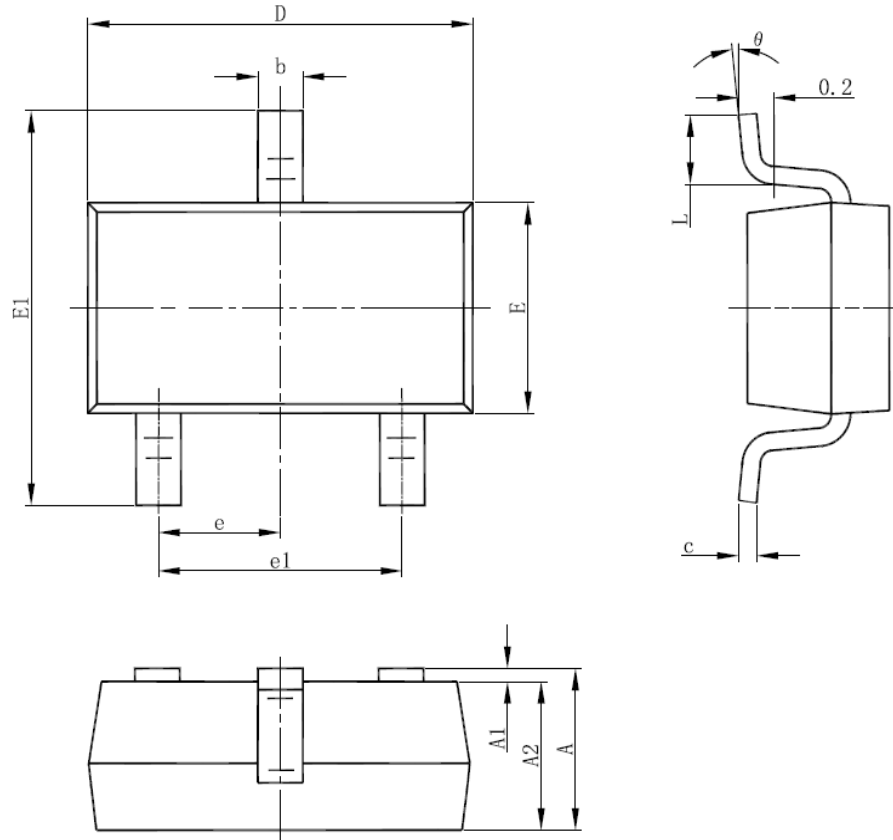

Symbol	Dimensions In Millimeters		Dimensions In Inches	
	Min	Max	Min	Max
A	1.050	1.250	0.041	0.049
A1	0.000	0.100	0.000	0.004
A2	1.050	1.150	0.041	0.045
b	0.300	0.500	0.012	0.020
c	0.100	0.200	0.004	0.008
D	2.820	3.020	0.111	0.119
E	1.500	1.700	0.059	0.067
E1	2.650	2.950	0.104	0.116
e	0.950(BSC)		0.037(BSC)	
e1	1.800	2.000	0.071	0.079
L	0.300	0.600	0.012	0.024
θ	0°	8°	0°	8°

SOT-23-5L package outline dimensions

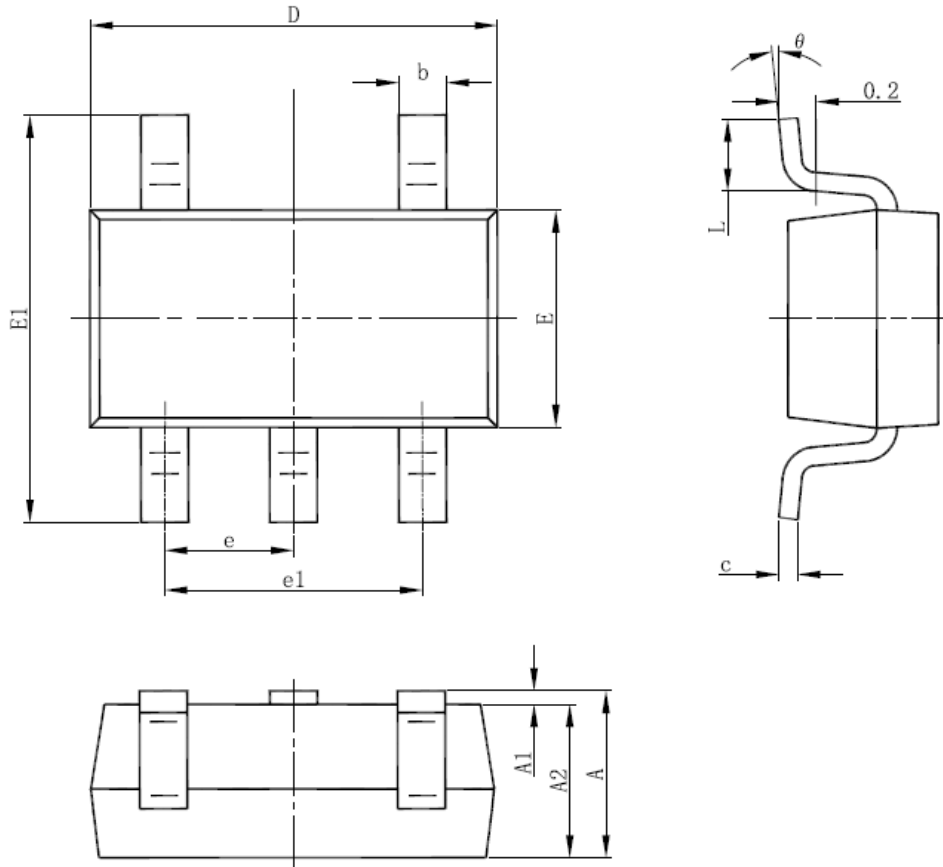

Symbol	Dimensions In Millimeters		Dimensions In Inches	
	Min	Max	Min	Max
A	1.050	1.250	0.041	0.049
A1	0.000	0.100	0.000	0.004
A2	1.050	1.150	0.041	0.045
b	0.300	0.500	0.012	0.020
c	0.100	0.200	0.004	0.008
D	2.820	3.020	0.111	0.119
E	1.500	1.700	0.059	0.067
E1	2.650	2.950	0.104	0.116
e	0.950(BSC)		0.037(BSC)	
e1	1.800	2.000	0.071	0.079
L	0.300	0.600	0.012	0.024
θ	0°	8°	0°	8°