

RoHS Compliant Standard

T-5032-2PIN-GLASS

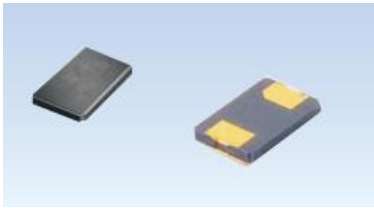

Features 特性

- Nominal Frequency 标称频率: MHz
- Suited for portable devices with low current consumption
適合於低功耗的便攜設備
- For a clock source in electronic equipments 適用於电子設備的時鐘源

Item	Mode	T-5032-2PIN-GLASS	Conditions
Frequency Range	标称频率	16MHz	
Frequency Tolerance	調整頻差	±30ppm Max	at 25°C
Freq. Tol. Over Temp.	溫度頻差	±30ppm Max	-40~+85°C
Operating Temp. Range	工作溫度範圍	-40~+85°C	
Storage Temp. Range	保存溫度範圍	-40~+85°C	
Series Resistance	諧振電阻	50Ω Max	
Load Capacitance	負載電容	20pF	
Shunt Capacitance	靜態電容	7.0pF Max	
Drive Level	激勵電平	100μw Max	
Aging	老化率	±3ppm/year Max	
Insulation Resistance	絕緣阻抗	500Mohm/Min	DC100V±15V

OUTLINE DIMENSIONS (unit: mm)

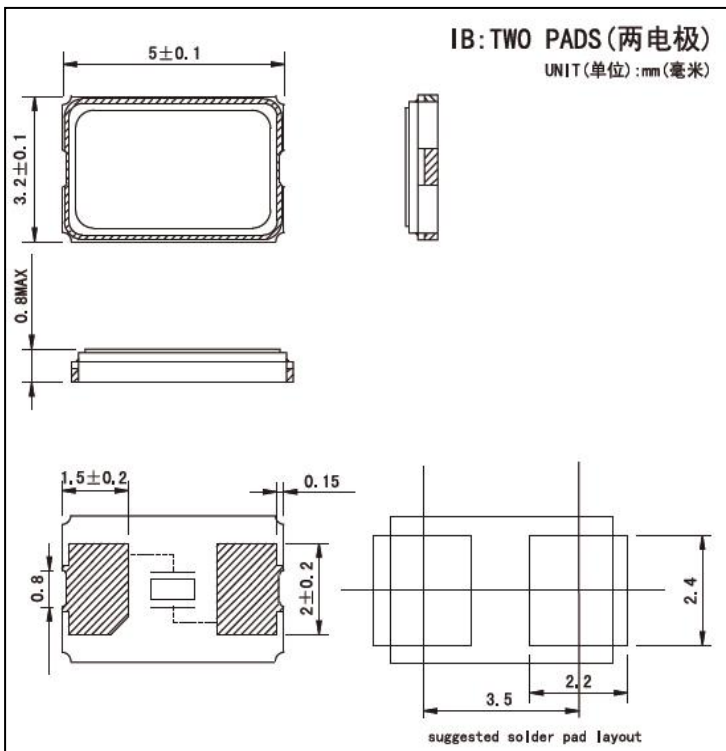

序号 NO	项目 ITEM	条件 CONDITIONS	合格标准 BASIS OF VERDICT
1	跌落 Drop	100cm高处自由跌落到3cm厚硬木板上,3次 High:100cm;Thickness:3cm;3 times	$\Delta FL \leq \pm 5\text{ppm}$ $\Delta RS \leq 5 \Omega \text{ or } \pm 15\%$ (whichever is larger)
2	振动 Vibration	频率 Frequency: 10~2000Hz; 加速度幅度 Acceleration: 100 m/s ² 振动方向 Direction: X, Y, Z 振动时间 Duration: 每个方向30分钟 30 min/direction. 循环次数 Times: 12次	$\Delta FL \leq \pm 5\text{ppm}$ $\Delta RS \leq 5 \Omega \text{ or } \pm 15\%$ (Whichever is Larger)
3	热冲击 Thermal shock	-55℃~+125℃, 1000个循环 最大转换时间: 5分钟; 停留时间: 5分钟 -55℃~+125℃, For 1000 cycles Maximum conversion time: 5 minutes;Remain time:5 minutes	$\Delta FL \leq \pm 10\text{ppm}$ $\Delta RS \leq 5 \Omega \text{ or } \pm 20\%$ (Whichever is Larger)
4	湿热 Humidity	温度:85℃;湿度:85%;时间:1000小时 Temp:85℃;Humidity:85%;Times:1000h	$\Delta FL \leq \pm 10\text{ppm}$ $\Delta RS \leq 5 \Omega \text{ or } \pm 20\%$ (Whichever is Larger)
5	低温 Cold resistance	温度:-40℃;时间:1000小时 Temp:-40℃;Times:1000h	$\Delta FL \leq \pm 10\text{ppm}$ $\Delta RS \leq 5 \Omega \text{ or } \pm 20\%$ (Whichever is Larger)
6	湿度抗性 Humidity resistance	高温: 65℃ (10小时, 含升温), 低温: 25℃ (2小时, 含降温), 湿度90%, 循环10次, 每循环24小时 High-Temperature: 65℃±2℃ (10 hours, including heating), Low-Temperature: 25℃±2℃ (2 hours, including cooling), Humidity: 90%, for 10 cycles (24 hours/cycle)	$\Delta FL \leq \pm 10\text{ppm}$ $\Delta RS \leq 5 \Omega \text{ or } \pm 20\%$ (Whichever is Larger)
7	机械冲击 Mechanical shock	峰值 Peak: 100g's 持续时间 Duration: 6ms 波形 Waveform: 半正弦波 Half-sine 变化速度 Velocity Change: 12.3 ft / sec 振动方向 Direction: +X, -X, +Y, -Y, +Z, -Z 每个方向各3次 3 times/direction	$\Delta FL \leq \pm 5\text{ppm}$ $\Delta RS \leq 5 \Omega \text{ or } \pm 15\%$ (Whichever is Larger)

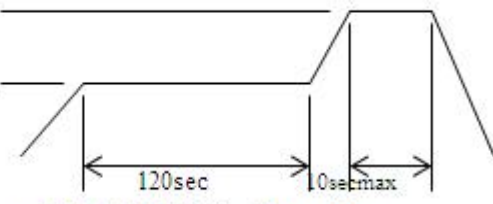
序号 NO	项目 ITEM	条件 CONDITIONS	合格标准 BASIS OF VERDICT
8	回流焊 Reflow	<p>260°C±5°C</p>  <p>150°C±5°C</p> <p>120sec</p> <p>10sec max</p> <p>CYCLE TIME周期: 200 sec Max.</p>	<p>$\Delta FL \leq \pm 5 \text{ ppm}$</p> <p>$\Delta RS \leq 5 \Omega$ or $\pm 15\%$ (Whichever is Larger)</p> <p>No Rusty</p>
9	引脚拉力(SMD型) Pin pull	<p>按照要求分别提供1.8kg的切向推力（60秒）以及1.8kg的垂直拉力（60秒） In accordance with the requirements, offering 1.8kg tangential thrust (60 seconds), and 1.8kg vertical pull (60 seconds) respectively.</p>	<p>电极不断裂 No Rupture Observed</p>
10	老化 Aging	<p>温度:85°C;时间:1000小时 Temp:85°C;Times:1000h</p>	<p>$\Delta FL \leq \pm 10 \text{ ppm}$</p> <p>$\Delta RS \leq 5 \Omega$ or $\pm 10\%$ (Whichever is Larger)</p>
11	可焊性 solderability	<p>温度: 235°C±5°C; 时间: 2秒 Temperature: 235°C±5°C; Time: 2sec</p>	<p>浸锡率≥95% Solder Coverage≥95%</p>
备注	可靠性项目中的4、5、6、10，需在试验结束后24±2小时进行测试。		

T-5032編帶規格TAPE AND REEL SPECIFICATION

- 1.編帶規格符合美國電子工業協會EIA-481-B電子元件編帶標準Tape and Reel form conform to EIA-481-B
- 2.每盤的晶體元件數量為1000只。The quantity of crystal units per reel shall be 1000PCS.
- 3.在包裝盒及載帶盤的表面貼上標籤，注明必需的資訊A "LABEL" on which necessary information is clearly written is on the surface of packing box and the reel.

載帶尺寸圖CARRIER TAPE DIMENSIONS

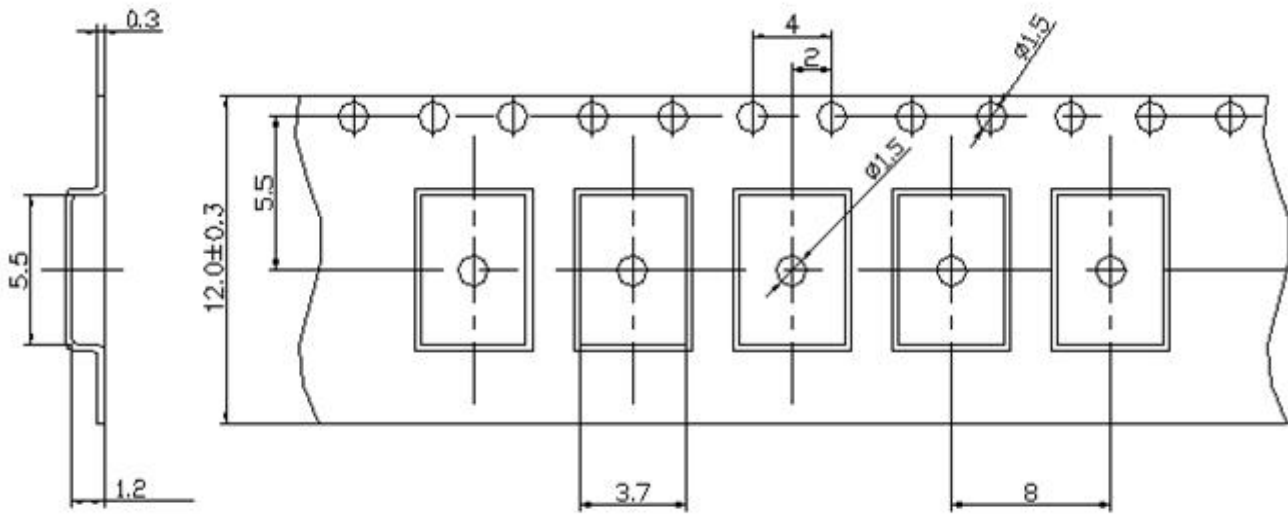

載帶盤尺寸圖REEL DIMENSIONS

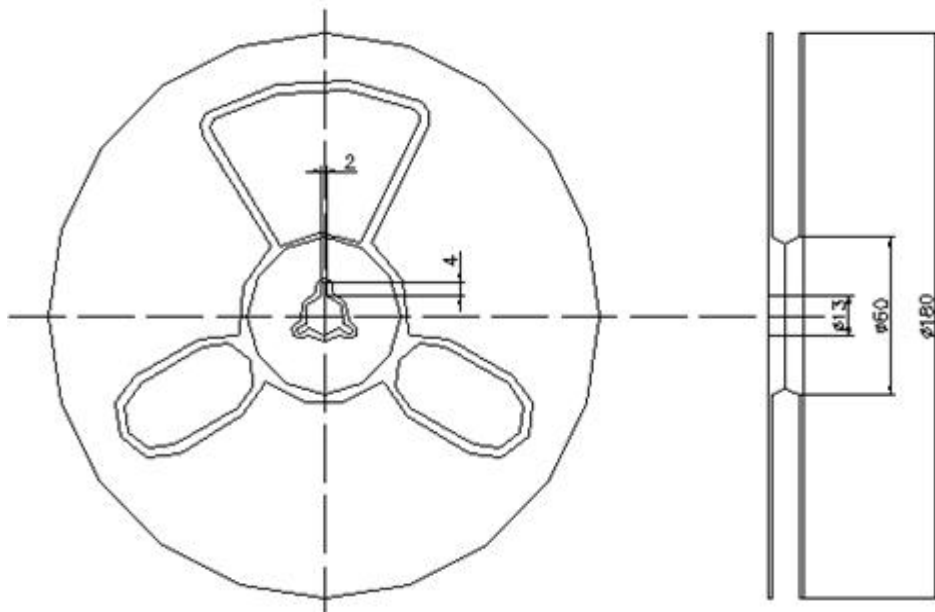

■ 编带方式(TAPING METHOD)

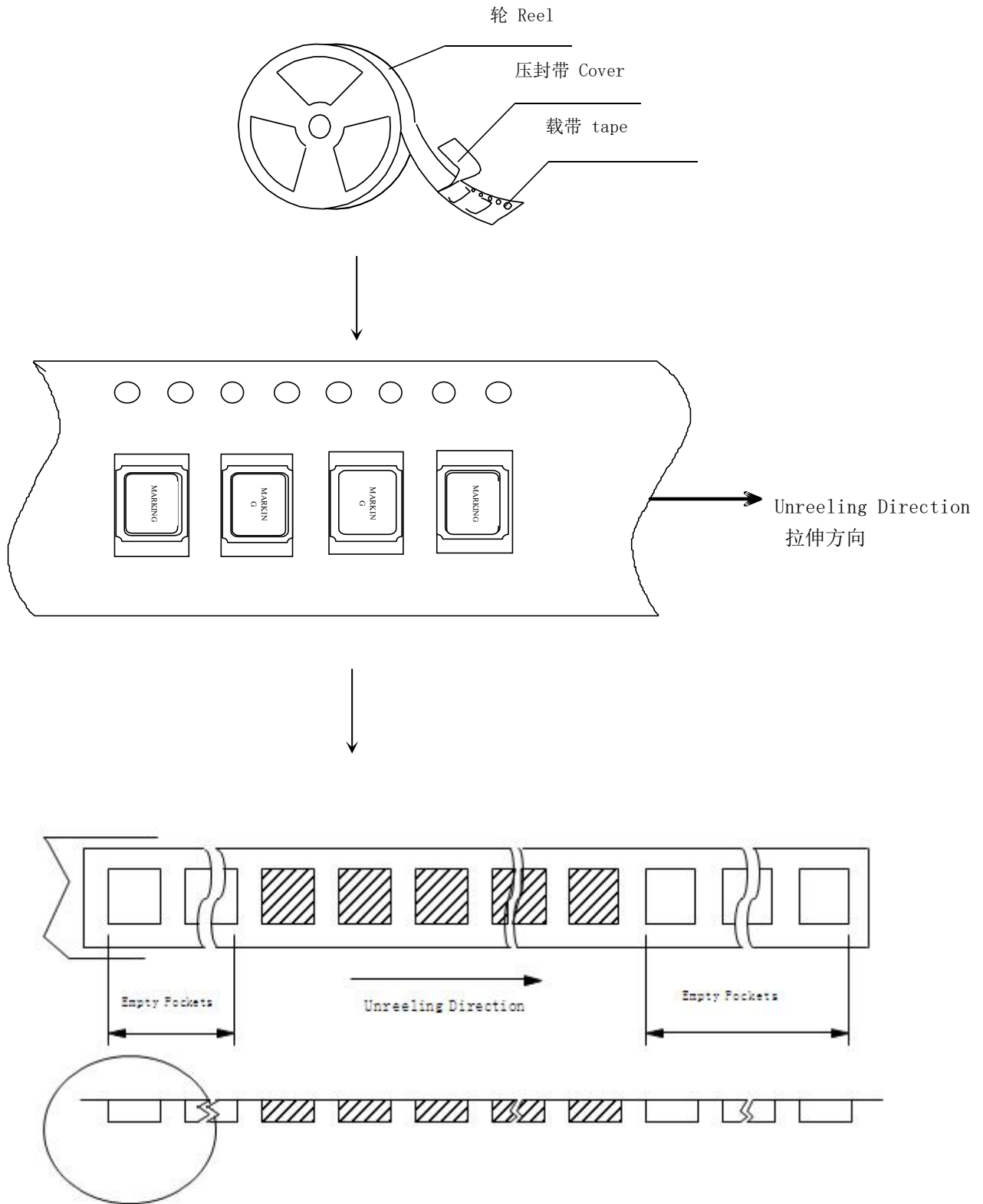

■ 包装(PACKAGE)

1. 自封袋(Bag)

1000只=1 轮

1000pcs=1 Reel

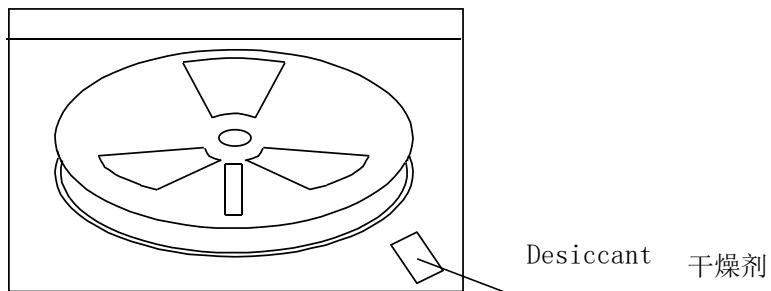

2. 内包装(Inside package)

1 轮=1 盒

1 Reel=1 box

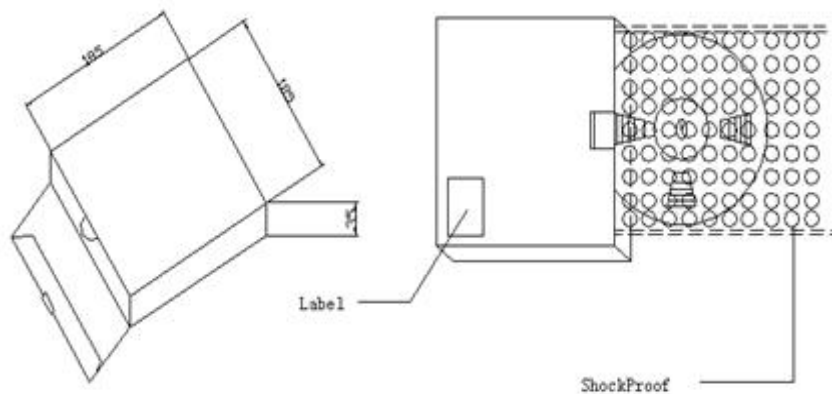

3. 外包装(outside Package)

10 盒=1 箱

10 box=1 carton

