

LP1485WT1G

S-LP1485WT1G

-20V P-Channel Power Mosfet

1. FEATURES

- $V_{(BR)DSS} = -20V$
 $R_{DS(ON)} \leq 250m\Omega @ V_{GS} = -1.8V, I_D = -1.0A$
 $R_{DS(ON)} \leq 140m\Omega @ V_{GS} = -4.5V, I_D = -1.0A$
- We declare that the material of product compliance with RoHS requirements and Halogen Free.
- S- prefix for automotive and other applications requiring unique site and control change requirements; AEC-Q101 qualified and PPAP capable.

2. APPLICATIONS

- Power Management in Note book
- Portable Equipment
- Battery Powered System
- Load Switch
- DSC

3. DEVICE MARKING AND RESISTOR VALUES

Device	Marking	Shipping
LP1485WT1G	W15	3000/Tape&Reel
S-LP1485WT1G	W15	3000/Tape&Reel

4. MAXIMUM RATINGS(Ta = 25°C)

Parameter	Symbol	Limits	Unit
Drain-Source voltage	V _{DS}	-20	V _{dc}
Gate-Source Voltage	V _{GS}	±8	V _{dc}
Continuous Drain Current	Steady-State @t ≤ 5s	-1.4	A
		-1.5	
Pulse Drain Current @T _p =10μs	IDM	-3.0	

5. THERMAL CHARACTERISTICS

Parameter	Symbol	Limits	Unit
Power Dissipation FR-4 Board (Note 1) @ TA = 25°C @ TA = 70°C	PD	0.29 0.19	W
Thermal Resistance, Junction-to-Ambient(Note 1)	RθJA	430	°C/W
Junction and Storage temperature	T _J , T _{stg}	-55~+150	°C

1.1-in2 2oz Cu PCB board.

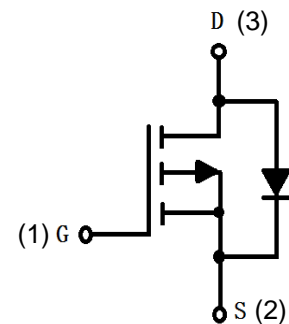
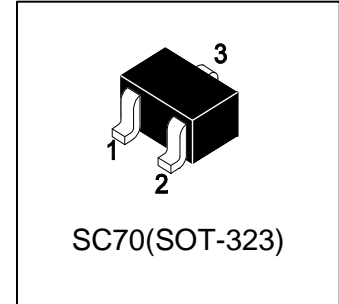

6. ELECTRICAL CHARACTERISTICS (Ta= 25°C)

Characteristic	Symbol	Min.	Typ.	Max.	Unit	
Static						
Drain-Source Voltage (ID = -250μA, VGS = 0V)	V(BR)DSS	-20	-	-	V	
Zero Gate Voltage Drain Current (VDS = -16V, VGS = 0V)	IDSS	-	-	-1	μA	
Gate-body Leakage Current (VDS = 0V, VGS = ±8V)	IGSS	-	-	±100	nA	
Gate Threshold Voltage (VDS = VGS, ID = -250μA)	VGS(th)	-0.4	-0.6	-1.0	V	
Static Drain-Source On resistance (VGS = -1.8V, ID = -1A) (VGS = -2.5V, ID = -1A) (VGS = -4.5V, ID = -1A)	RDS(ON)		180 130 110	250 170 140	mΩ	
Diode Forward Voltage (IS = -1A, VGS = 0V)	VSD	-	-0.79	-1.5	V	
Dynamic						
Input Capacitance	(VDS = -10V, VGS = 0V, f=1MHz)	Ciss	-	400	-	pF
Output Capacitance		Coss	-	41	-	
Reverse Transfer Capacitance		Crss	-	30	-	
Total Gate Charge	(VGS = -4.5V, ID = -1.2A, VDS = -10V)	Qg	-	4	-	nC
Gate Source Charge		Qgs	-	0.6	-	
Gate Drain Charge		Qgd	-	0.85	-	
Turn-On Delay Time	(VGS = -4.5V, VDS = -10V, ID = -1.2A, RGEN = 6Ω)	td(on)	-	5	-	ns
Turn-On Rise Time		tr	-	11	-	
Turn-Off Delay Time		td(off)	-	30	-	
Turn-Off Fall Time		tf	-	18	-	
Gate Resistance (VDS = 0V, VGS = 0V, f=1MHz)	Rg	-	12	-	Ω	
Maximum Body-diode Continuous Current	IS	-	-	-1	A	
Body-diode Reverse Recovery Time (Is = -1.0A, di/dt=100A/μs)	trr	-	30	-	ns	
Body-diode Reverse Recovery Charge (Is = -1.0A, di/dt=100A/μs)	Qrr	-	12	-	nC	

7. ELECTRICAL CHARACTERISTICS CURVES

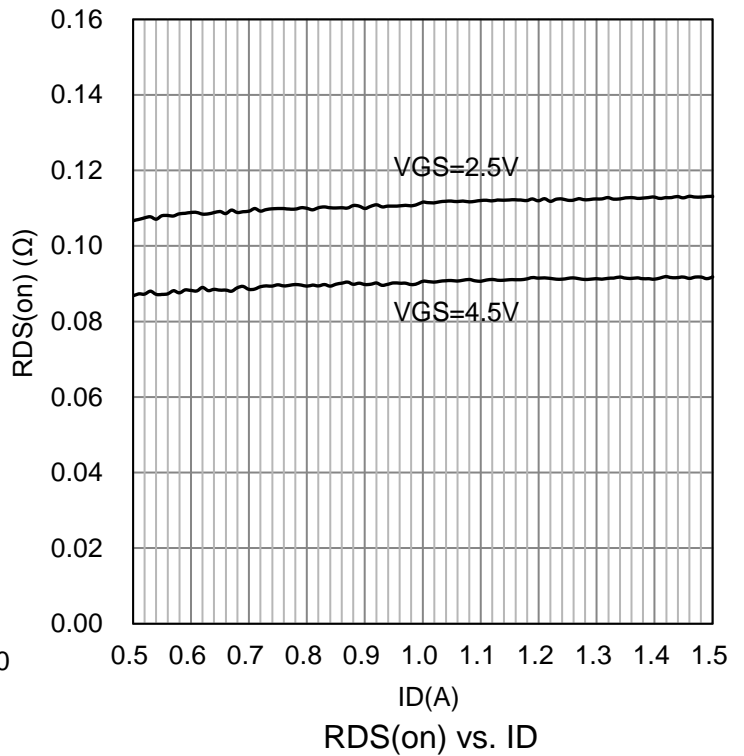
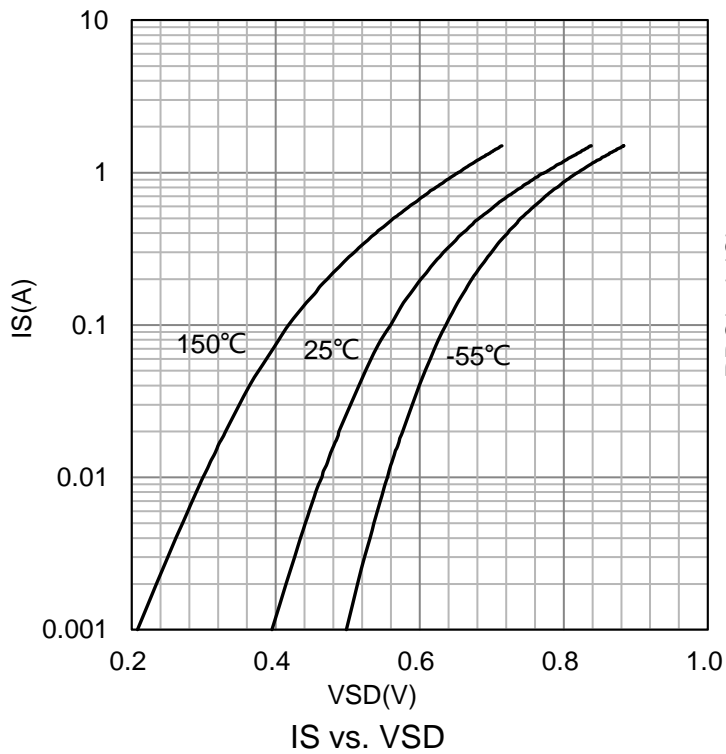
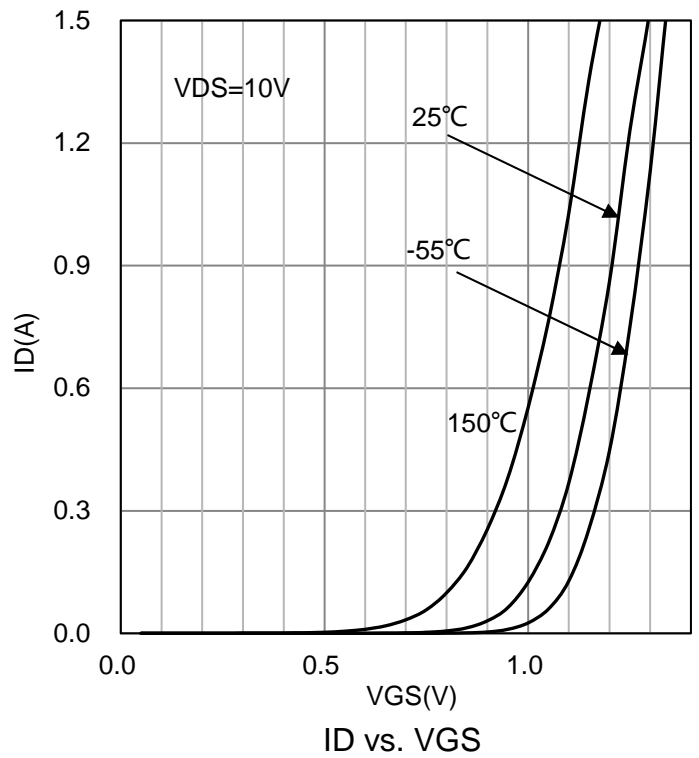
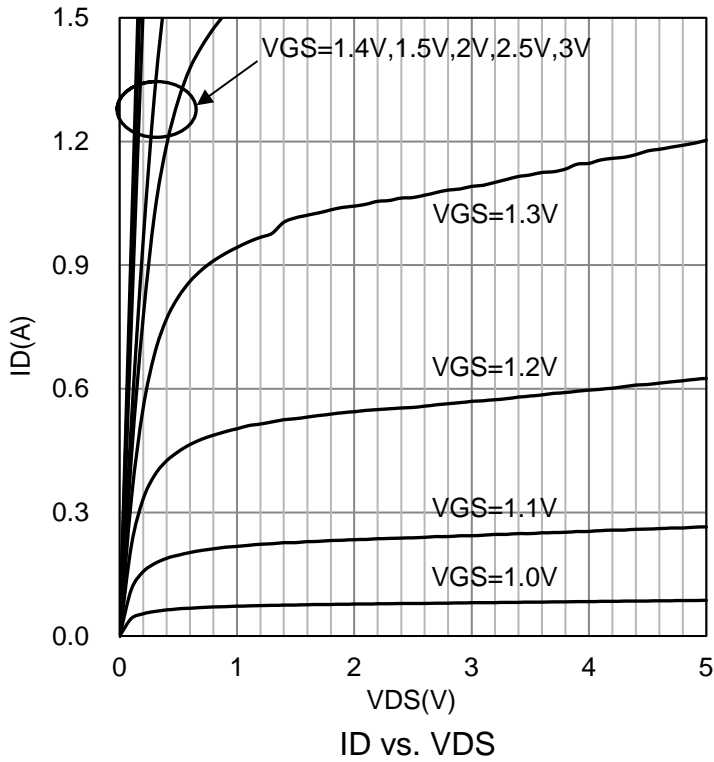

7. ELECTRICAL CHARACTERISTICS CURVES(Con.)

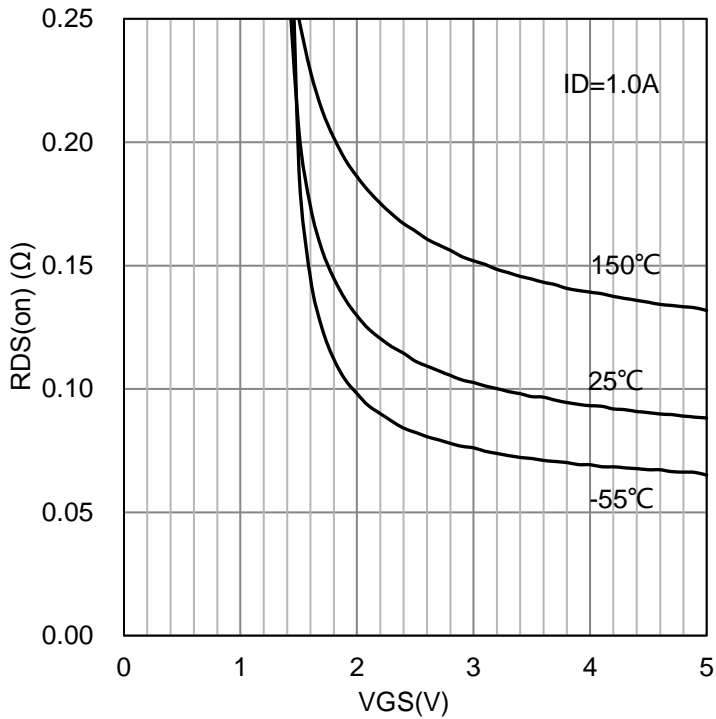

RDS(on) vs. VGS

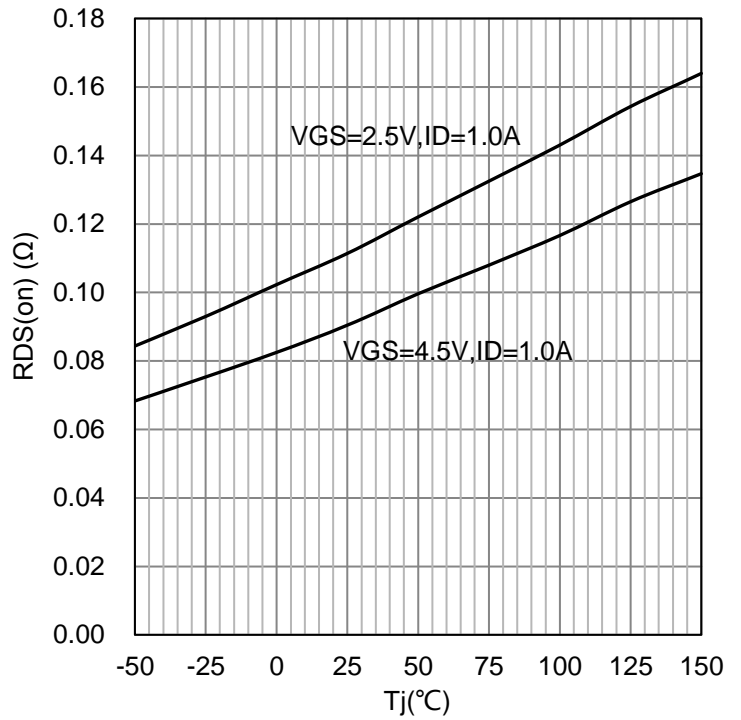

RDS(on) vs. Tj

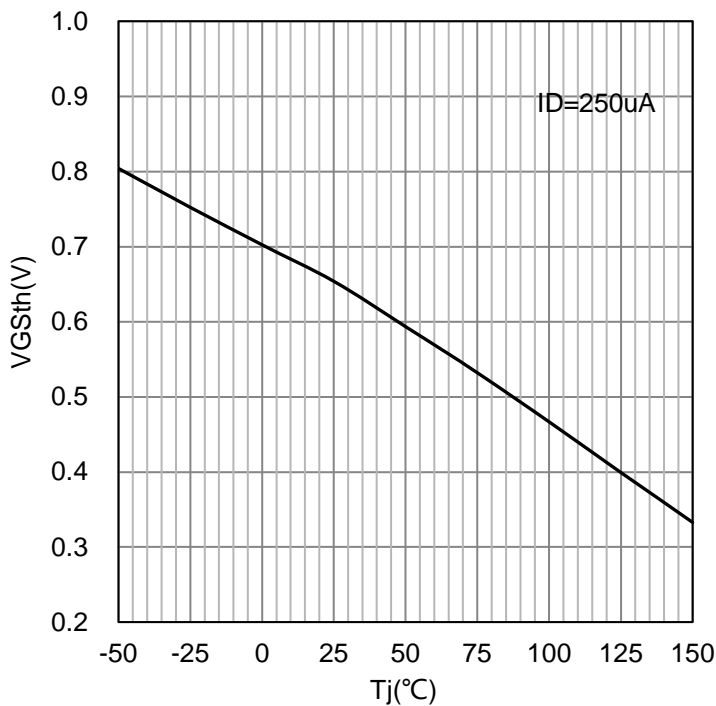

VGSth vs. Tj

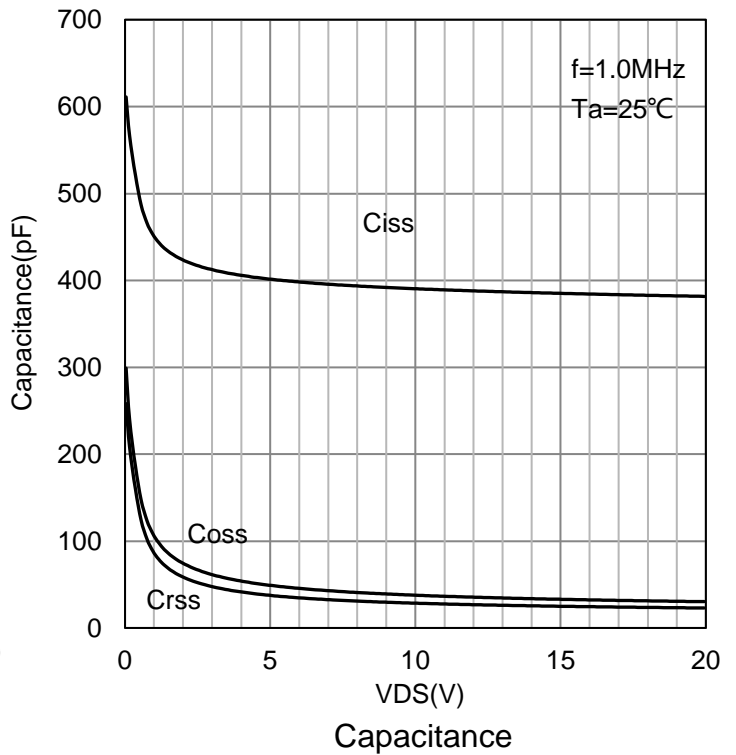

Capacitance

8. OUTLINE AND DIMENSIONS

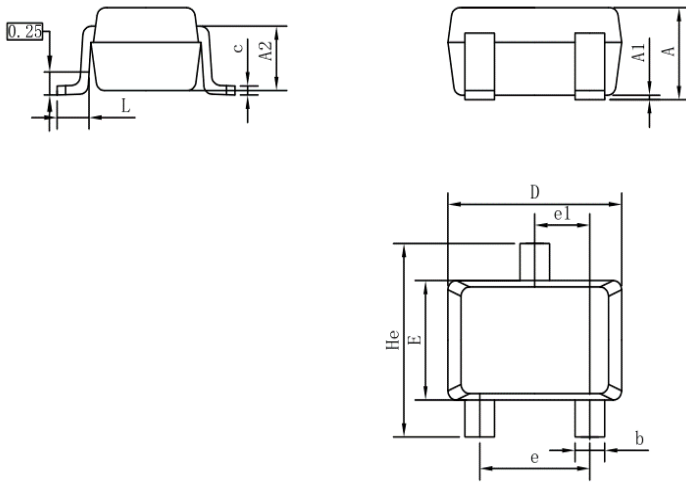

SC70			
DIM	MIN	NOR	MAX
A	0.80	0.95	1.00
A1	0.00	0.05	0.10
A2	0.7 REF		
b	0.30	0.35	0.40
c	0.10	0.15	0.25
D	1.80	2.05	2.20
E	1.15	1.30	1.35
e	1.20	1.30	1.40
e1	0.65 BSC		
L	0.20	0.35	0.56
He	2.00	2.10	2.40
ALL Dimension in mm			

9 SOLDERING FOOTPRINT

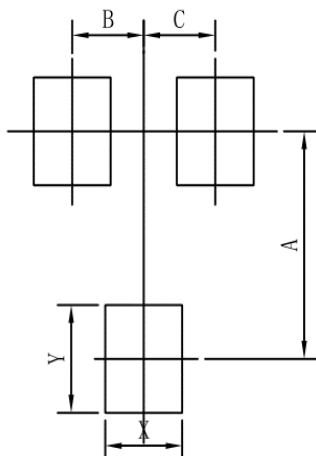

SC70	
DIM	MIN
A	1.90
B	0.65
C	0.65
X	0.70
Y	0.90

DISCLAIMER

- Before you use our Products, you are requested to carefully read this document and fully understand its contents. LRC shall not be in any way responsible or liable for failure, malfunction or accident arising from the use of any LRC's Products against warning, caution or note contained in this document.
- All information contained in this document is current as of the issuing date and subject to change without any prior notice. Before purchasing or using LRC's Products, please confirm the latest information with a LRC sales representative.