

Electronic housing - P 1-EMG 12



2947187

<https://www.phoenixcontact.com/us/products/2947187>

Please be informed that the data shown in this PDF document is generated from our Online Catalog. Please find the complete data in the user documentation. Our General Terms of Use for Downloads are valid.

PCB for assembling electronic components

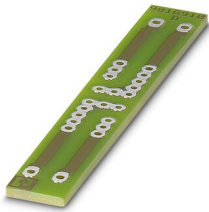

Commercial Data

Item number	2947187
Packing unit	1 pc
Minimum order quantity	5 pc
Note	Made to Order (non-returnable)
Sales Key	A13
Product Key	ACHCBZ
Catalog Page	Page 709 (C-1-2013)
GTIN	4017918082659
Weight per Piece (including packing)	4.6 g
Weight per Piece (excluding packing)	4.6 g
Customs tariff number	85340019
Country of origin	DE

Electronic housing - P 1-EMG 12

2947187

<https://www.phoenixcontact.com/us/products/2947187>



Technical Data

Product properties

Product type	PCB
--------------	-----

Electronic housing - P 1-EMG 12

2947187

<https://www.phoenixcontact.com/us/products/2947187>

Drawings

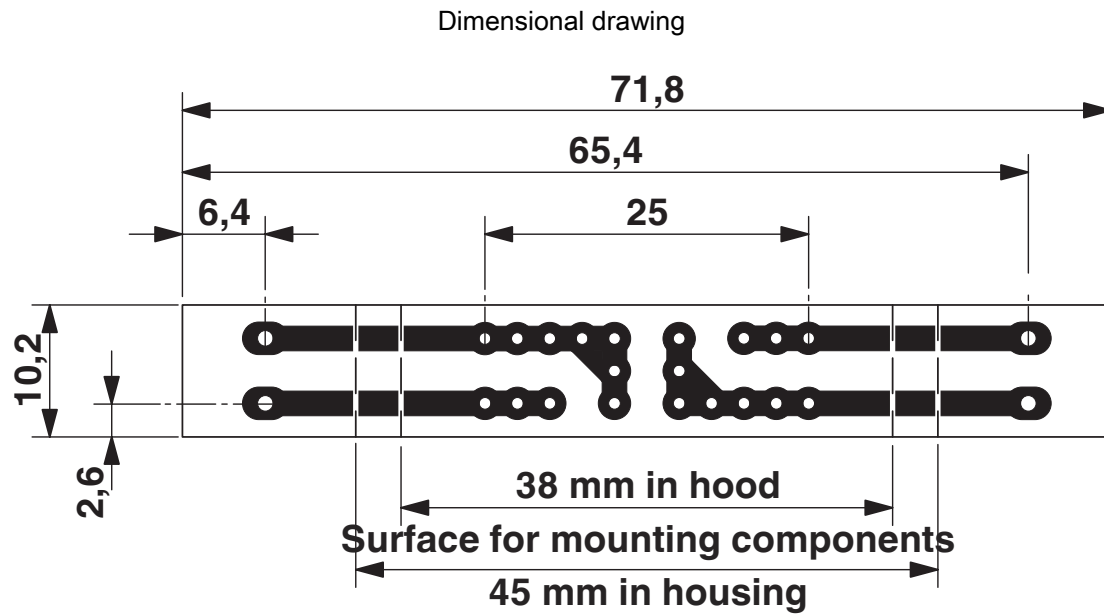

Pitch 5 mm

a = Area for mounting components, 38 mm in the hood

b = Area for mounting components, 45 mm in the housing

Electronic housing - P 1-EMG 12



2947187

<https://www.phoenixcontact.com/us/products/2947187>

Classifications

ECLASS

ECLASS-9.0

27182702

ETIM

ETIM 7.0

EC001031

Electronic housing - P 1-EMG 12



2947187

<https://www.phoenixcontact.com/us/products/2947187>

Environmental Product Compliance

China RoHS	Environmentally friendly use period: unlimited = EFUP-e No hazardous substances above threshold values
------------	---

Phoenix Contact 2022 © - all rights reserved
<https://www.phoenixcontact.com>

Phoenix Contact USA
586 Fulling Mill Road
Middletown, PA 17057, United States
(+717) 944-1300
info@phoenixcon.com