



CrossLink LIF-MD6000 Master Link Board - Revision B

Evaluation Board User Guide

FPGA-EB-02010-1.6

September 2021

Disclaimers

Lattice makes no warranty, representation, or guarantee regarding the accuracy of information contained in this document or the suitability of its products for any particular purpose. All information herein is provided AS IS, with all faults and associated risk the responsibility entirely of the Buyer. Buyer shall not rely on any data and performance specifications or parameters provided herein. Products sold by Lattice have been subject to limited testing and it is the Buyer's responsibility to independently determine the suitability of any products and to test and verify the same. No Lattice products should be used in conjunction with mission- or safety-critical or any other application in which the failure of Lattice's product could create a situation where personal injury, death, severe property or environmental damage may occur. The information provided in this document is proprietary to Lattice Semiconductor, and Lattice reserves the right to make any changes to the information in this document or to any products at any time without notice.

Contents

Acronyms in This Document	5
1. Introduction	6
2. Headers and Test Connections	8
3. Programming Circuit	9
3.1. Bridging Circuit	9
3.2. I ² C Expander	10
4. Power Supply	11
5. Status Indicators	13
6. SMA I/O Link Board	14
7. Breakout I/O Link Board	16
8. Ordering Information	19
Appendix A. LIF-MD6000-ML-EVN-BRD Schematics	20
Appendix B. LIF-MD6000-ML-EVN-BRD Bill of Materials	28
Appendix C. SMA-IOL-EVN-BRD Schematics	37
Appendix D. SMA-IOL-EVN-BRD Bill of Materials	38
Appendix E. B-IOL-EVN-BRD Schematics	39
Appendix F. B-IOL-EVN-BRD Bill of Materials	40
References	41
Technical Support Assistance	42
Revision History	43

Figures

Figure 1.1. Top View of Master Link Rev B Board and its Key Components	6
Figure 1.2. Bottom View of Master Link Rev B Board	7
Figure 3.1. Programming Block	9
Figure 3.2. Bridging Block	10
Figure 3.3. I ² C Expander Block	10
Figure 4.1. Power Supply Block	11
Figure 6.1. Top View of SMA I/O Link Board	15
Figure 6.2. Bottom View of SMA I/O Link Board	15
Figure 7.1. Top View of Breakout I/O Link Board	18
Figure 7.2. Bottom View of Breakout I/O Link Board	18
Figure A.1. LIF-MD6000 Master Link Rev B Board Block Diagram	20
Figure A.2. FTDI Interface	21
Figure A.3. Power Regulator Interface	22
Figure A.4. MIPI Block – MIPI Tx	23
Figure A.5. Bank 1, 2 – LVDS Rx	24
Figure A.6. Bank0, Flash Interface	25
Figure A.7. I ² C Expander	26
Figure A.8. Layout Guidelines	27
Figure C.1. SMA Debug Board	37
Figure E.1. 100MILS_DEBUG Header	39

Tables

Table 2.1. Headers and Test Connectors	8
Table 4.1. Power LEDs	11
Table 4.2. Device Power Rail Summary and Test Points	12
Table 5.1. Status LED I/O Map	13
Table 6.1. Headers and Test Connectors	14
Table 6.2. U1 Connector Description	14
Table 7.1. Headers and Test Connectors	16
Table 7.2. U1 Connector Description	16
Table 7.3. J2 Header Description	17
Table 8.1. Ordering Information	19

Acronyms in This Document

A list of acronyms used in this document.

Acronym	Definition
CMOS	Complementary Metal-Oxide Semiconductor
CSI-2	Camera Serial Interface
DSI	Display Serial Interface
FTDI	Future Technology Devices International
I ² C	Inter-Integrated Circuit
I/O	Input/Output
LVDS	Low-Voltage Differential Signaling
MIPI	Mobile Industry Processor Interface
SPI	Serial Peripheral Interface

1. Introduction

This document describes the Lattice Semiconductor CrossLink™ LIF-MD6000 Master Link Board – Revision B that supports a variety of demos, encompassing different signaling logic standards bridging with MIPI® CSI-2/DSI interface. The board’s key component is the CrossLink Family device that features built in MIPI D-PHY hard blocks to support different bridging solutions.

For the latest information about this board, including optional Tx/Rx Link boards, demo files, further documentation and more, see the Lattice website at: www.latticesemi.com/masterlink.

For details about the CrossLink device, refer to [CrossLink Family Data Sheet \(FPGA-DS-02007\)](#).

The content of this user guide includes descriptions of on-board jumper settings, programming circuit, a complete set of schematics, and bill of materials for LIF-MD6000 Master Link Rev B board.

Refer to Appendix A, B, C, D, E, F for the schematics and BOM of the CrossLink LIF-MD6000 Master Link Rev B board and the schematics and BOMs of the Breakout I/O Link and SMA I/O Link boards that are included in the demo kit.

Circuits on the development kit board:

- Programming Circuit
 - Mini USB Type-B connector to FTDI
 - FTDI to CrossLink using SPI
 - FTDI to XO3LF device using JTAG
- CrossLink
 - MIPI CSI-2/DSI hard block
 - Bridging of multiple signaling standards
 - SPI flash configuration
 - General Purpose Input/Output
 - LED display
- LCMXO3LF-1300E
 - I²C muxing

Figure 1.1 shows the top view of the LIF-MD6000 Master Link Rev B board and its key components. Figure 1.2 shows the bottom view of the board.

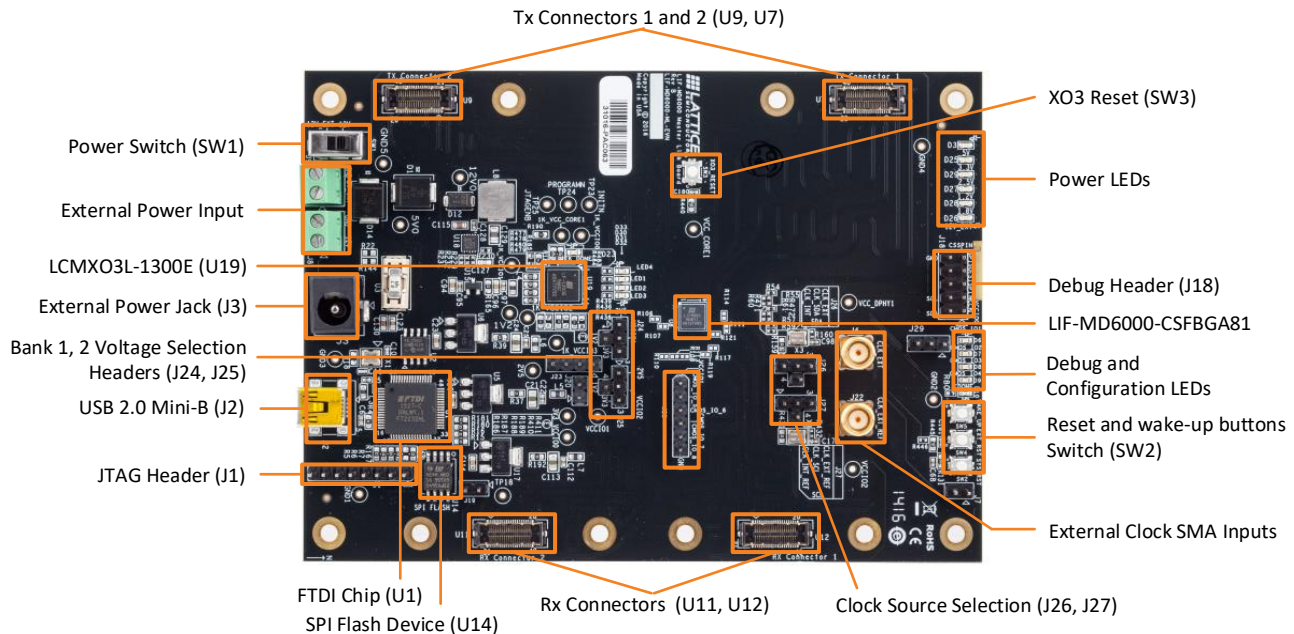

Figure 1.1. Top View of Master Link Rev B Board and its Key Components

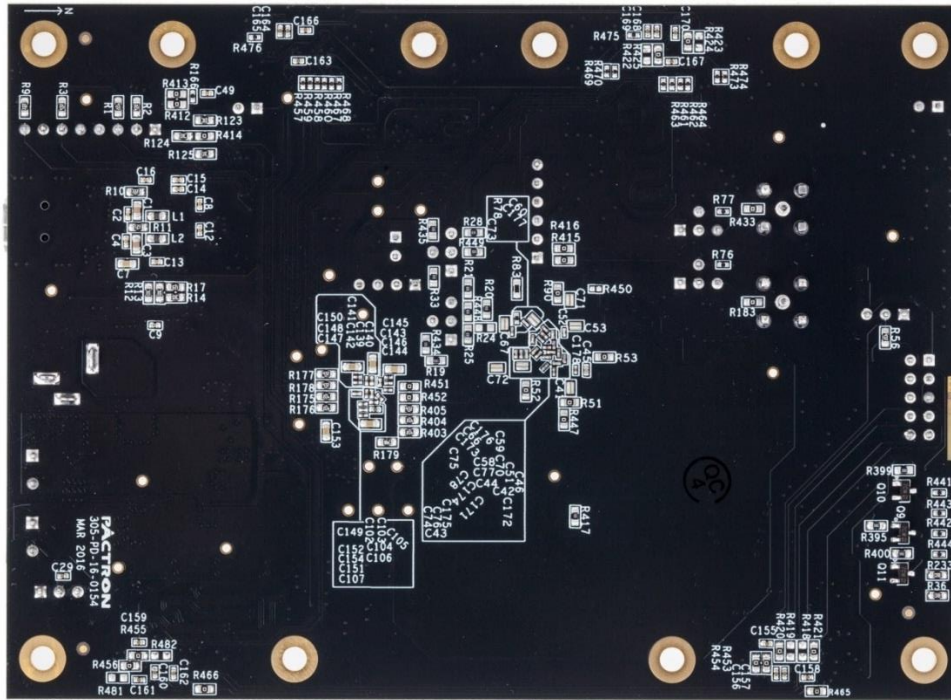

Figure 1.2. Bottom View of Master Link Rev B Board

2. Headers and Test Connections

Figure 1.1 shows the top view of the Master Link Rev B board. The headers and test connections on the board provide access to LIF-MD6000 Master Link demo board circuits. Table 2.1 lists the headers and test connectors.

Table 2.1. Headers and Test Connectors

Part	Description	Setting
J1	External JTAG interface – For LCMXO3 only	—
J2	Mini-B USB connector	—
J3	External power jack	—
J4	External clock input for MIPI D-PHY reference clock	—
J7	SW2 selector	OPEN-NOP, SHORT-CONFIGURATION RESET
J8	External 12 V terminal block	Open
J9	External 5 V terminal block	Open
J18	External SP/I ² C access	—
J19	SPI Flash chip select	OPEN-OFF, SHORT-ON
J20	LIF-MD6000 chip select	OPEN-OFF, SHORT-ON
J22	External reference clock input for MIPI D-PHY reference clock	—
J23	Debug Header for LCMXO3L device	—
J24	VCCIO1 Bank voltage selector	1-2 (2.5 V), 2-3 (3.3 V), 2-4 (1.2 V)
J25	VCCIO2 Bank voltage selector	1-2 (2.5 V), 2-3 (3.3 V), 2-4 (1.2 V)
J26	Internal/External clock and I2C SDA Mux	1-2 (CLK_INT), 2-3 (CLK_EXT), 2-4 (SDA)
J27	Internal/External reference clock and I2C SCL Mux	1-2 (CLK_INT_REF), 2-3 (CLK_EXT_REF), 2-4 (SCL)
J28	Reveal analyzer signal connector	—
J29	Reset signal voltage selector	1-2 (VCCIO2), 2-3 (VCCIO0)
SW1	External adaptor power ON/OFF	—
SW2	Configuration reset for LIF-MD6000	—
SW3	External reset for LCMXO3L device	—
SW4*	External reset for LIF-MD6000 device	—
SW5	PMU WAKEUP Switch	—
U7	Tx Connectors for external interface	—
U9	Tx Connectors for external interface	—
U11	Rx Connectors for external interface	—
U12	Rx Connectors for external interface	—

***Note:** Some CrossLink demos utilize this reset signal to ball G9 of Bank 2 while it is configured as a 1.2 V Bank. However, LVCMOS12 inputs are no longer supported across all 3 Banks. Lattice Diamond® Software 3.9 and later does not allow this signal to be placed on a 1.2 V Bank. If it is necessary to recompile one of these demo projects, the necessary modifications should be made to the project and the board to move this reset signal to a non-1.2 V Bank on CrossLink.

3. Programming Circuit

The Mini-B USB connector is used for programming the board by using Lattice Diamond Programmer software. [Figure 3.1](#) shows the programming block of LIF-MD6000 Master Link Rev B board.

The Mini-B USB connector interfaces to the FTDI FT2232H IC. The FTDI IC works with Diamond programmer software to provide interfaces for:

- JTAG – to program MachXO3 LCMXO3LF-1300E
- SPI – to program both CrossLink, and SPI Flash Memory

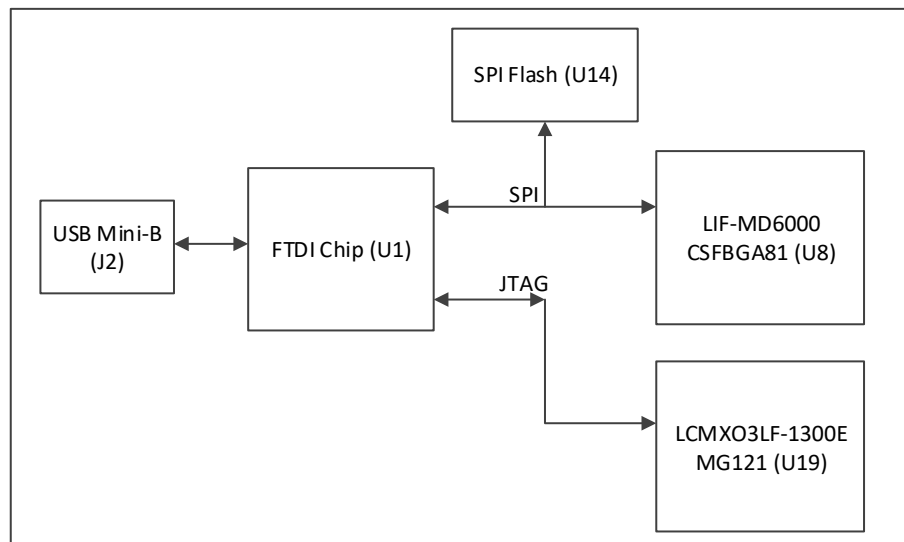

Figure 3.1. Programming Block

3.1. Bridging Circuit

[Figure 3.2](#) shows the block diagram of bridging of different standard interfaces. The CrossLink device is used as a bridging device that supports a variety of I/O standards. This demo board supports development of the following interface bridges:

- 1:1 MIPI DSI Display Interface Bridge
- 1:2 MIPI DSI Display Interface Bridge
- 2:1 MIPI CSI-2 Image Sensor Aggregator Bridge
- CMOS to MIPI CSI-2 Image Sensor Interface Bridge
- MIPI CSI-2 to CMOS Image Sensor Interface Bridge
- MIPI DSI to CMOS Display Interface Bridge
- OpenLDI LVDS to MIPI DSI Display Interface Bridge
- CMOS to MIPI DSI Display Interface Bridge

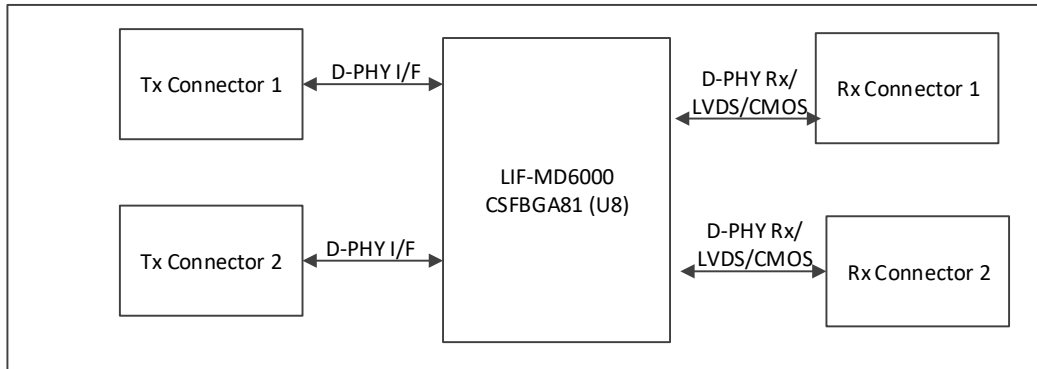

Figure 3.2. Bridging Block

3.2. I²C Expander

Figure 3.3 shows the block diagram of the I²C expander. The LCMXO3LF-1200E device is used as an I²C expander and it supports a single master and multiple slave devices connected to the board. The master I²C interface is connected to the Tx header and the slave device I²C interface is connected to the Rx connectors supporting any slave device access from the master based on the slave address.

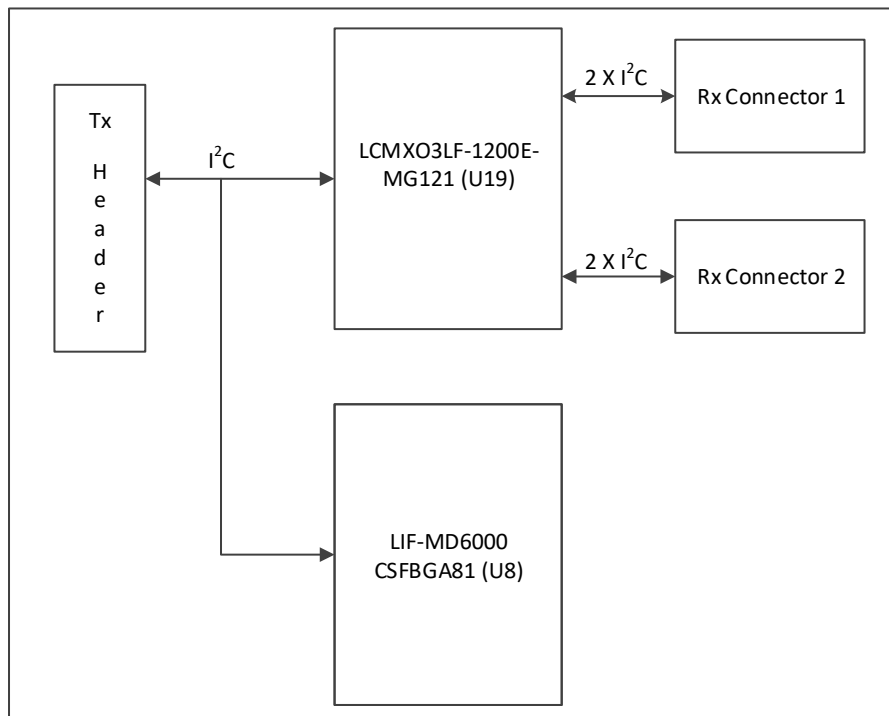

Figure 3.3. I²C Expander Block

4. Power Supply

The power supply to the development kit is provided by the Mini-B USB connector or from an external adaptor.

Figure 4.1 shows the power supply block of the CrossLink LIF-MD6000 Master Link Rev B board. The external adaptor provides 12 V power source through voltage regulators on the board to CrossLink and LCMXO3LF-1300E, as well as to the external boards connected to Tx and Rx Headers. The Mini-B USB connector provides 5 V to the various voltage regulators and is also used for device programming. Each I/O and core voltage rail on the board is accessible by a test point on the board. The current flowing to each rail can be measured using a 1 Ω resistor placed in the path of each voltage rail.

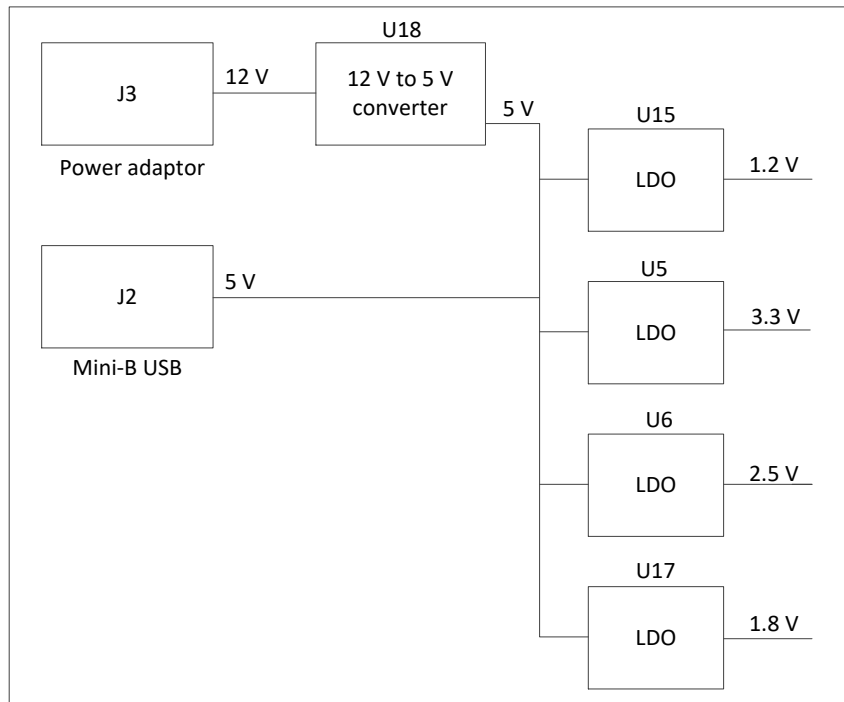

Figure 4.1. Power Supply Block

Table 4.1 lists the device power rails. There are five voltage regulators on the board used to supply the 5 V, 3.3 V, 2.5 V, 1.8 V, and 1.2 V rails. The input to these regulators is either from the Mini-B USB connector (J2), an external 12 V adaptor (J3), or an external power supply to the terminal blocks of J8 or J9. Switch SW1 is used to connect or disconnect the external 12 V adaptor power to the board.

Table 4.1. Power LEDs

Voltage Rail	LEDs	Color
12	D26	Green
5	D3	Green
3.3	D25	Green
2.5	D29	Green
1.8	D28	Green
1.2	D27	Green

Table 4.2 lists the board voltage rails, including the rail source voltage, test point number, and current sense resistor number.

Table 4.2. Device Power Rail Summary and Test Points

Voltage Rail	Source Rail	Current Sense Resistor	Test Points
12 V	—	—	12V0
5 V	12 V	—	5V0
+3.3 V	5 V	—	3V3
+2.5 V	5 V	—	2V5
+1.8 V	5 V	—	—
+1.2 V	5 V	—	1V2
VCCCORE	+1.2 V	R19	VCC_CORE1
VCCIO0	+2.5 V/+3.3 V	R20/R24	VCCIO0
VCCIO1	+1.2 V/+2.5 V/+3.3 V	R21/R25/R434/R448	VCCIO1
VCCIO2	+1.2 V/+2.5 V/+3.3 V	R28/R33/R435/R449	VCCIO2
VCC_DPHY	+1.2 V	R417	VCC_DPHY
1K_VCC_CORE	1.2 V	R190	1K_VCC_CORE1
1K_VCCIO0	+2.5 V/+3.3 V	R410/R411	1K_VCCIO0
1K_VCCIO1	+2.5 V/+3.3 V	R184/R185	1K_VCCIO1
1K_VCCIO2	+2.5 V/+3.3 V	R186/R187	1K_VCCIO2
1K_VCCIO3	+2.5 V/+3.3 V	R188/R189	1K_VCCIO3

5. Status Indicators

The LED status indicators on the board show power, configuration, and application status. [Table 5.1](#) lists the status LED I/O map.

Table 5.1. Status LED I/O Map

Device	LED	Net Name	Color
CrossLink	D6	CMOS_IO_1	Blue
CrossLink	D7	CMOS_IO_2	Blue
CrossLink	D8	CMOS_IO_3	Blue
CrossLink	D9	CMOS_IO_4	Blue
CrossLink	D10	CDONE	Green
LCMXO3LF-1300E	D23	DONE	Red

6. SMA I/O Link Board

The SMA I/O Link board connects to the CrossLink LIF-MD6000 Master Link Rev B board's Tx or Rx connectors (U7, U9, U11 or U12) and transfers signals to the respective SMA connectors.

Table 6.1. Headers and Test Connectors

Part	Description	Mapping to U1
J1	SMA connector for DCK_TX_P	Pin 1
J2	SMA connector for DCK_TX_N	Pin 2
J3	SMA connector for DATA0_TX_P	Pin 4
J4	SMA connector for DATA0_TX_N	Pin 5
J5	SMA connector for DATA1_TX_P	Pin 7
J6	SMA connector for DATA1_TX_N	Pin 8
J7	SMA connector for DATA2_TX_P	Pin 13
J8	SMA connector for DATA2_TX_N	Pin 14
J9	SMA connector for DATA3_TX_P	Pin 16
J10	SMA connector for DATA3_TX_N	Pin 17
J11	SMA connector for DATA4_TX_P	Pin 24
J12	SMA connector for DATA4_TX_N	Pin 25
J13	SMA connector for DATA5_TX_P	Pin 27
J14	SMA connector for DATA5_TX_N	Pin 28
U1	Connector to interface to CrossLink Master Link Rev B board	N/A

Table 6.2. U1 Connector Description

Pin	Name
1	CH4_DCK_P
2	CH4_DCK_N
3	GND
4	CH4_DATA0_P
5	CH4_DATA0_N
6	GND
7	CH4_DATA1_P
8	CH4_DATA1_N
9	GND
10	SN
11	SCLK
12	GND
13	CH4_DATA2_P
14	CH4_DATA2_N
15	GND
16	CH4_DATA3_P
17	CH4_DATA3_N
18	GND
19	12V
20	12V

Pin	Name
21	TBD
22	RESETN
23	PWR_5-0V
24	GND
25	GND
26	PWR_3-3V
27	GND
28	GND
29	PWR_1-8V
30	MOSI
31	MISO
32	PWR_1-8V
33	GND
34	GND
35	PWR_3-3V
36	GND
37	GND
38	PWR_5-0V
39	SDA
40	SCL

Note: U1 connector pin names may be different than the actual signal depending on which CrossLink LIF-MD6000 Master Link Rev B board connector this daughter board is connected to.

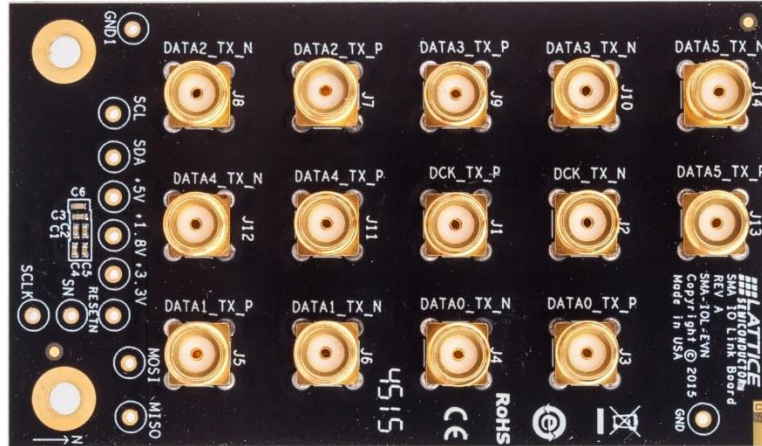

Figure 6.1. Top View of SMA I/O Link Board

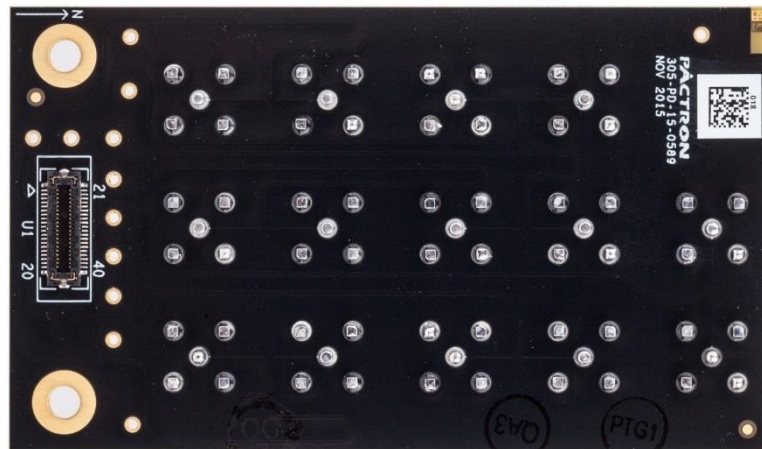

Figure 6.2. Bottom View of SMA I/O Link Board

7. Breakout I/O Link Board

The Breakout I/O Link board connects to the CrossLink LIF-MD6000 Master Link Rev B board's Tx or Rx connectors (U7, U9, U11 or U12) and transfers signals to the 26-pin header (J2).

Table 7.1. Headers and Test Connectors

Part	Description	Setting
J2	13x2 Header	—
U1	Connector to interface to CrossLink Master Link Rev B board	—

Table 7.2. U1 Connector Description

Pin	Connector Pin Name	Net Name
1	CH4_DCK_P	CH4_DCK_TX_P
2	CH4_DCK_N	CH4_DCK_TX_N
3	GND	GND
4	CH4_DATA0_P	CH4_DATA0_TX_P
5	CH4_DATA0_N	CH4_DATA0_TX_N
6	GND	GND
7	CH4_DATA1_P	CH4_DATA1_TX_P
8	CH4_DATA1_N	CH4_DATA1_TX_N
9	GND	GND
10	SN	SN
11	SCLK	SCLK
12	GND	NC
13	CH4_DATA2_P	CH4_DATA2_TX_P
14	CH4_DATA2_N	CH4_DATA2_TX_N
15	GND	GND
16	CH4_DATA3_P	CH4_DATA3_TX_P
17	CH4_DATA3_N	CH4_DATA3_TX_N
18	GND	GND
19	12V	NC
20	12V	NC

Pin	Connector Pin Name	Net Name
21	TBD	NC
22	RESETN	RESETN
23	PWR_5-0V	+5V
24	GND	CH4_DATA4_TX_P
25	GND	CH4_DATA4_TX_N
26	PWR_3-3V	+3.3V
27	GND	CH4_DATA5_TX_P
28	GND	CH4_DATA5_TX_N
29	PWR_1-8V	+1.8V
30	MOSI	MOSI
31	MISO	MISO
32	PWR_1-8V	+1.8V
33	GND	GND
34	GND	GND
35	PWR_3-3V	+3.3V
36	GND	NC
37	GND	NC
38	PWR_5-0V	+5V
39	SDA	SDA
40	SCL	SCL

Note: U1 connector pin names may be different than the actual signal depending on which CrossLink LIF-MD6000 Master Link Rev B board connector this daughter board is connected to.

Table 7.3. J2 Header Description

Pin	Name	Mapping to U1
1	+3.3V	N/A
2	+1.8V	N/A
3	RESETN	Pin 22
4	CH4_DCK_TX_P	Pin 1
5	SDA	Pin 39
6	CH4_DCK_TX_N	Pin 2
7	SCL	Pin 40
8	GND	N/A
9	GND	N/A
10	CH4_DATA0_TX_P	Pin 4
11	CH4_DATA3_TX_P	Pin 16
12	CH4_DATA0_TX_N	Pin 5
13	CH4_DATA3_TX_N	Pin 17
14	GND	N/A
15	GND	N/A
16	CH4_DATA1_TX_P	Pin 7
17	CH4_DATA4_TX_P	Pin 24
18	CH4_DATA1_TX_N	Pin 8
19	CH4_DATA4_TX_N	Pin 25
20	GND	N/A
21	GND	N/A
22	CH4_DATA2_TX_P	Pin 13
23	CH4_DATA5_TX_P	Pin 27
24	CH4_DATA2_TX_N	Pin 14
25	CH4_DATA5_TX_N	Pin 28
26	GND	N/A

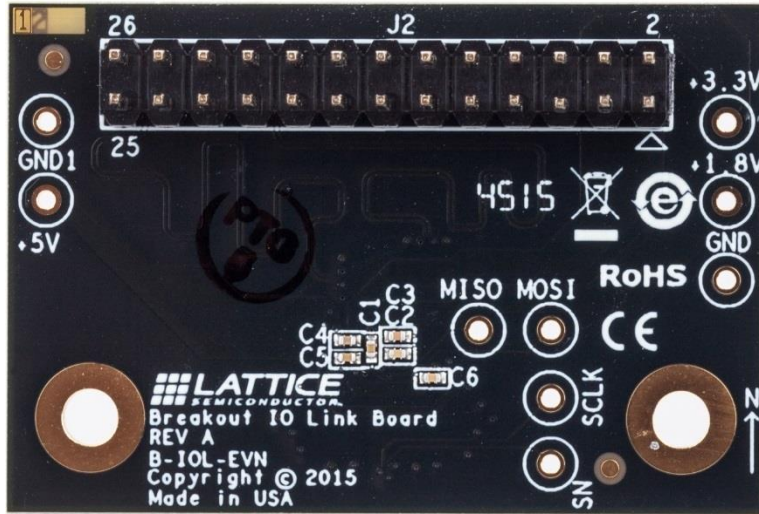

Figure 7.1. Top View of Breakout I/O Link Board

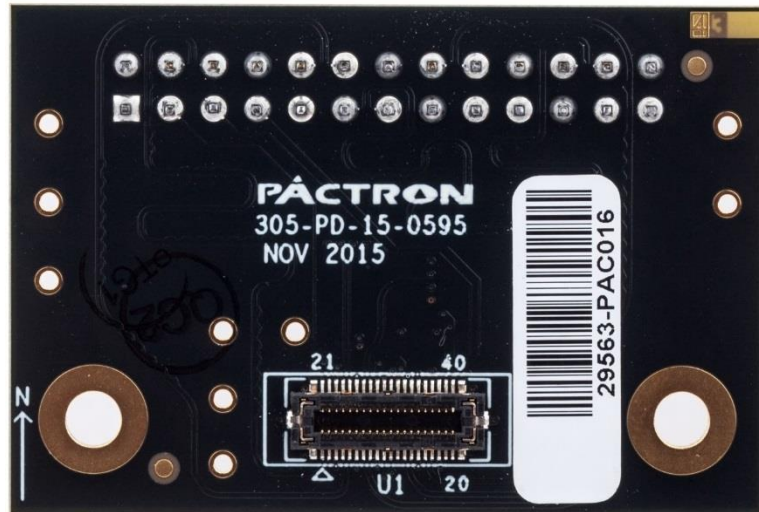



Figure 7.2. Bottom View of Breakout I/O Link Board

8. Ordering Information

Table 8.1. Ordering Information

Description	Ordering Part Number	China RoHS Environment-Friendly Use Period (EFUP)
CrossLink: LIF-MD6000 Master Link Rev B board (Includes 1 SMA I/O Link Board and 1 Breakout I/O Link Board)	LIF-MD6000-ML-EVN	
CrossLink: LIF-MD6000 I/O Link Boards (Includes 1 SMA I/O Link Board and 1 Breakout I/O Link Board)	LIFMD-IOL-EVN	

Appendix A. LIF-MD6000-ML-EVN-BRD Schematics

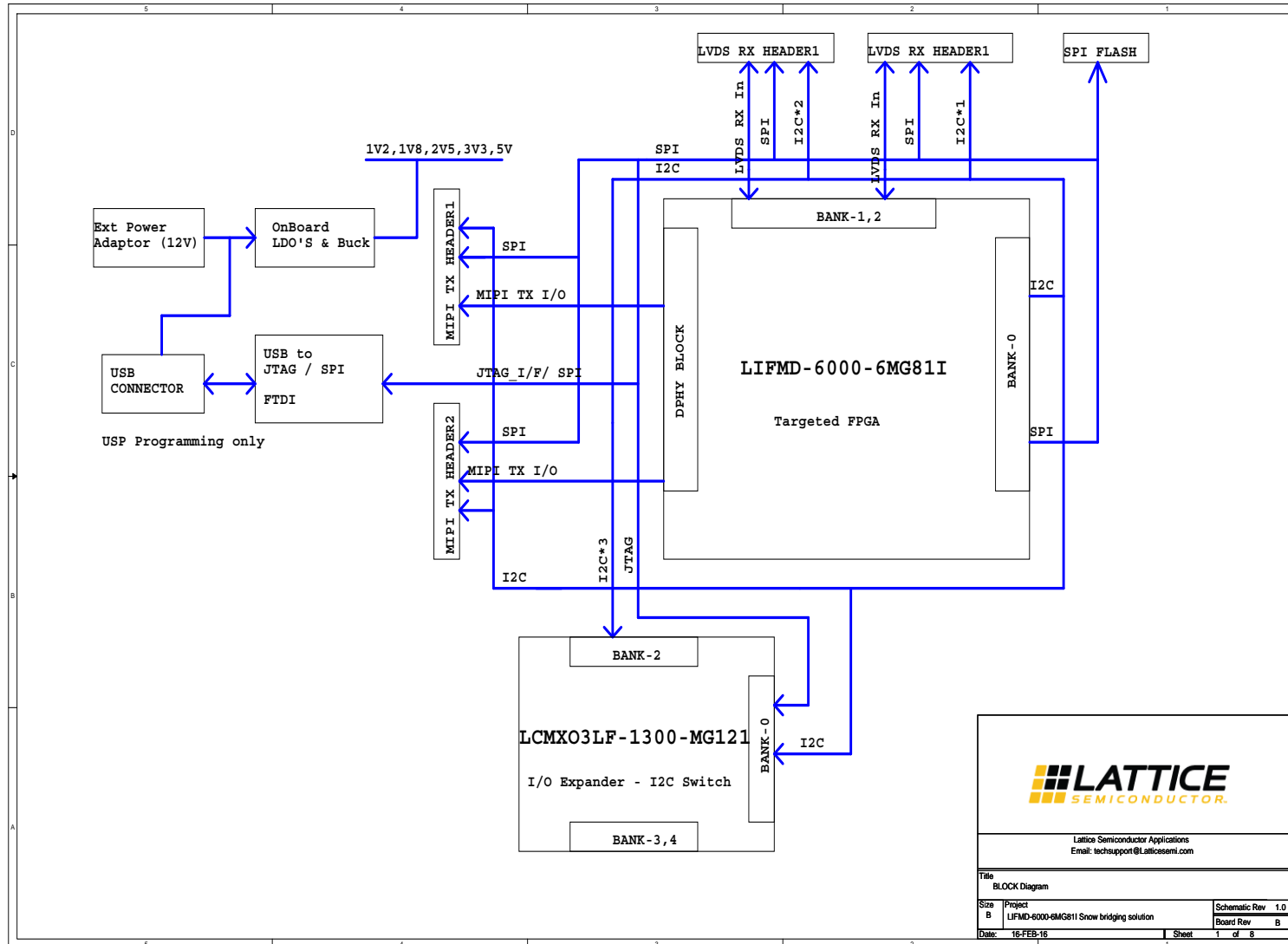

Figure A.1. LIF-MD6000 Master Link Rev B Board Block Diagram

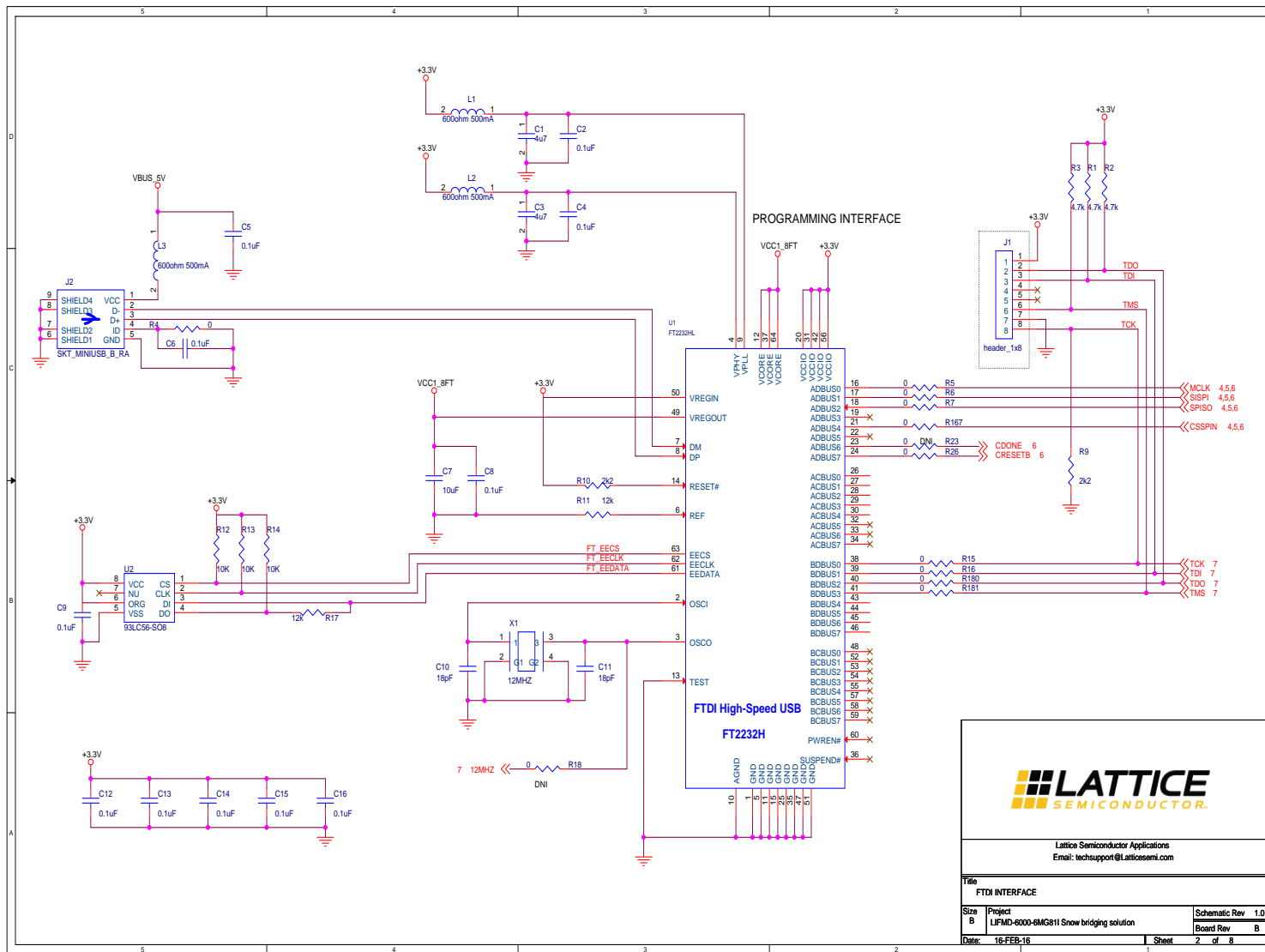

Figure A.2. FTDI Interface

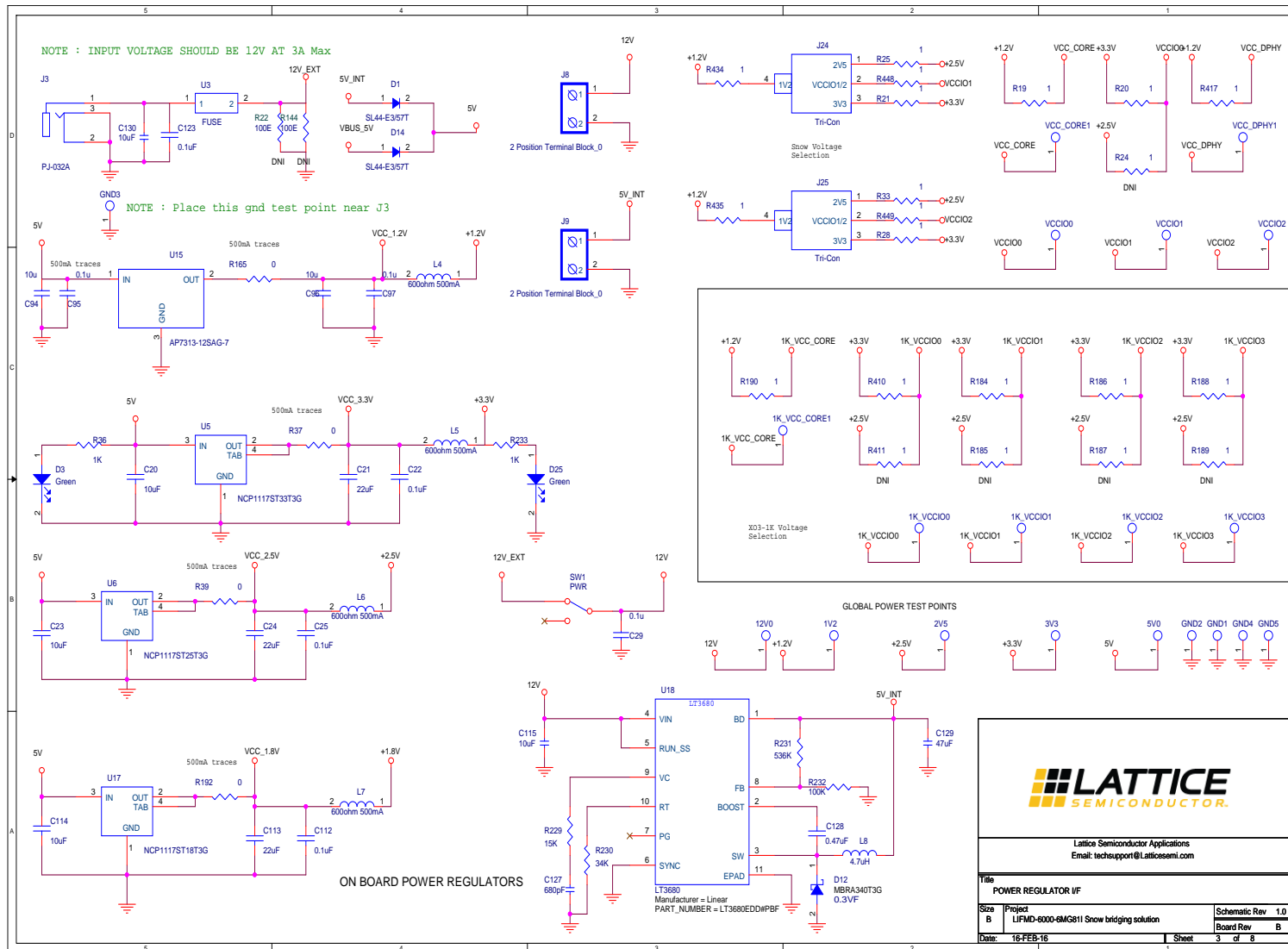

Figure A.3. Power Regulator Interface

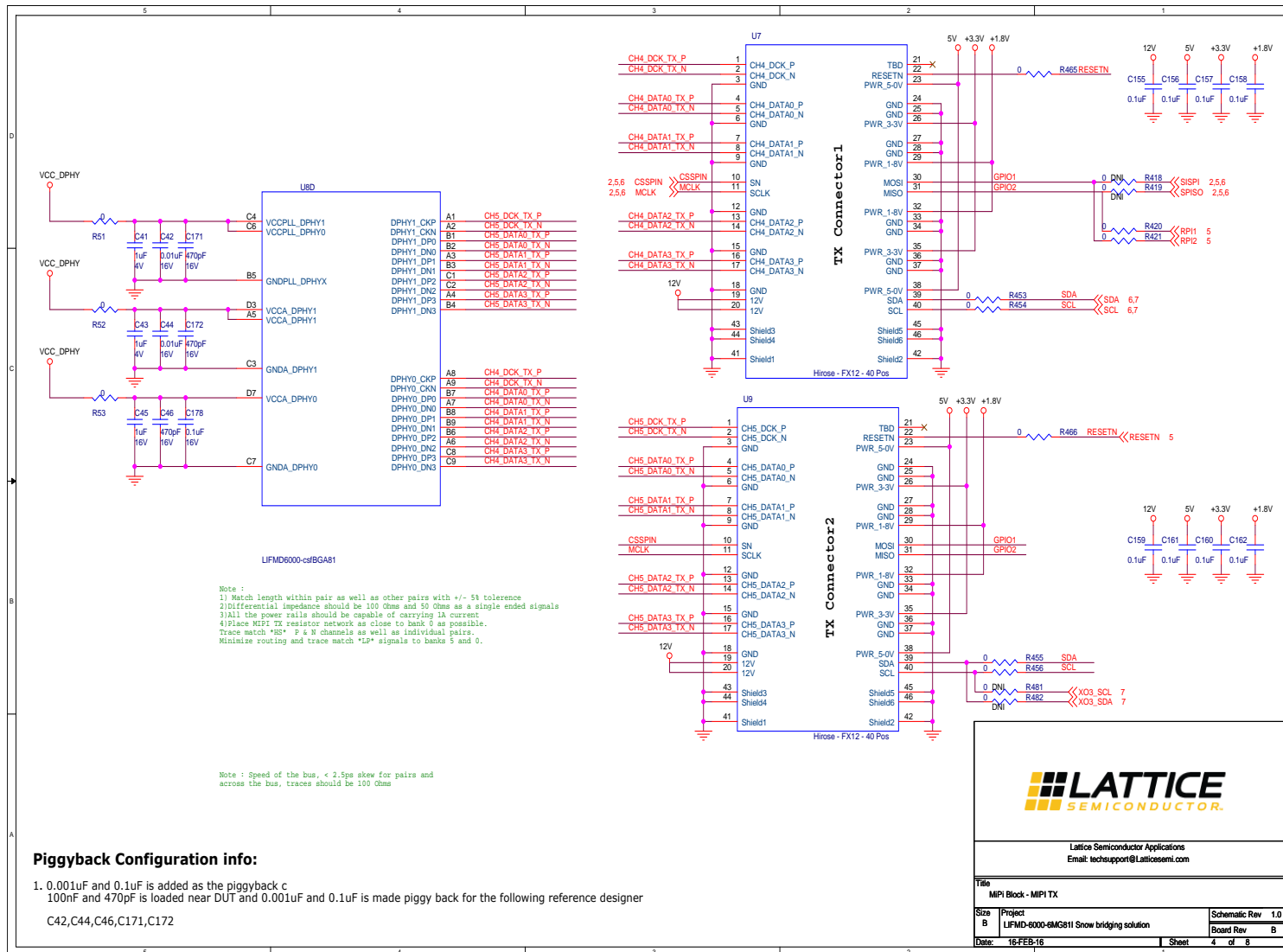

Figure A.4. MIPI Block – MIPI TX

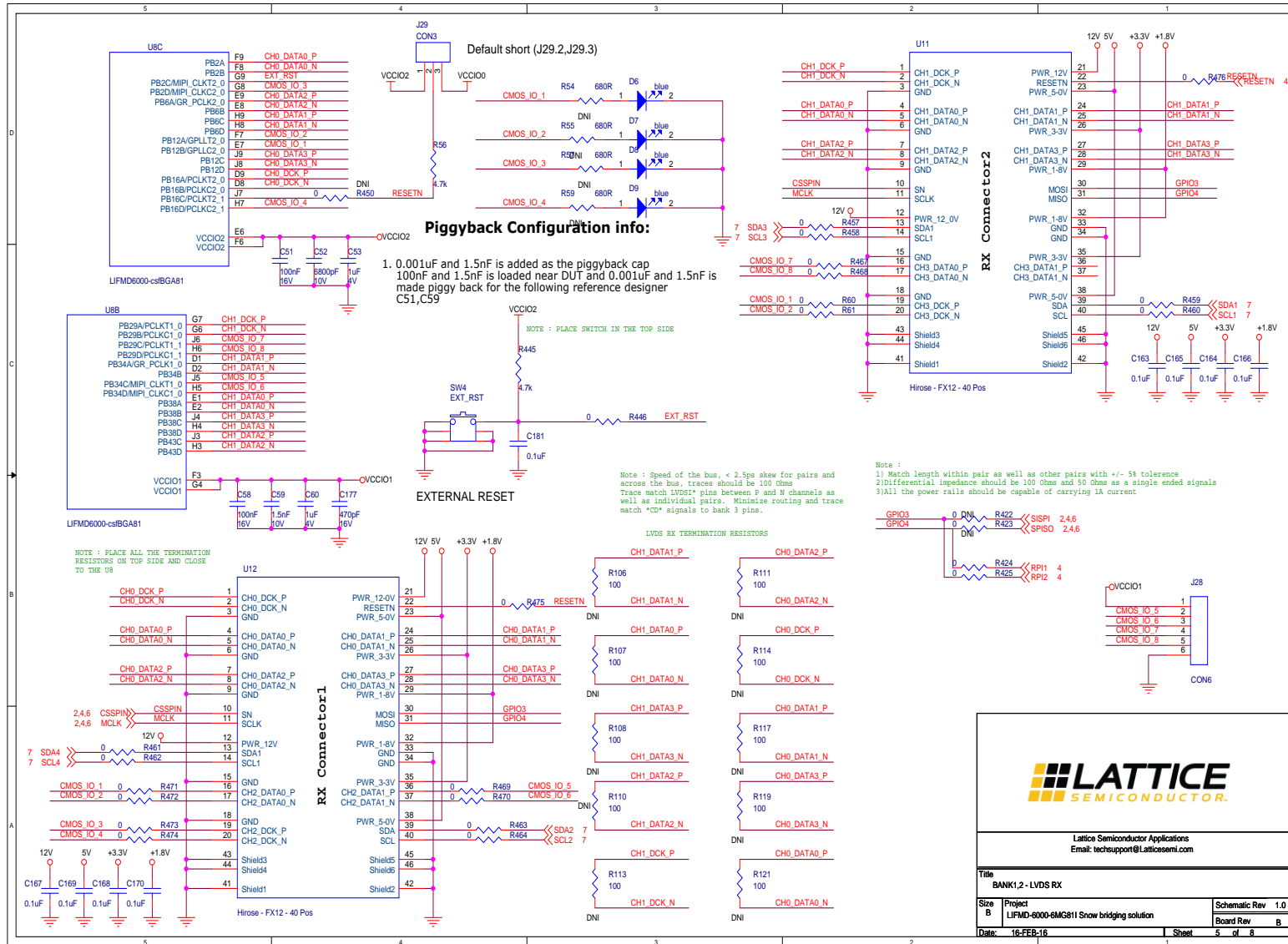

Figure A.5. Bank 1, 2 – LVDS Rx

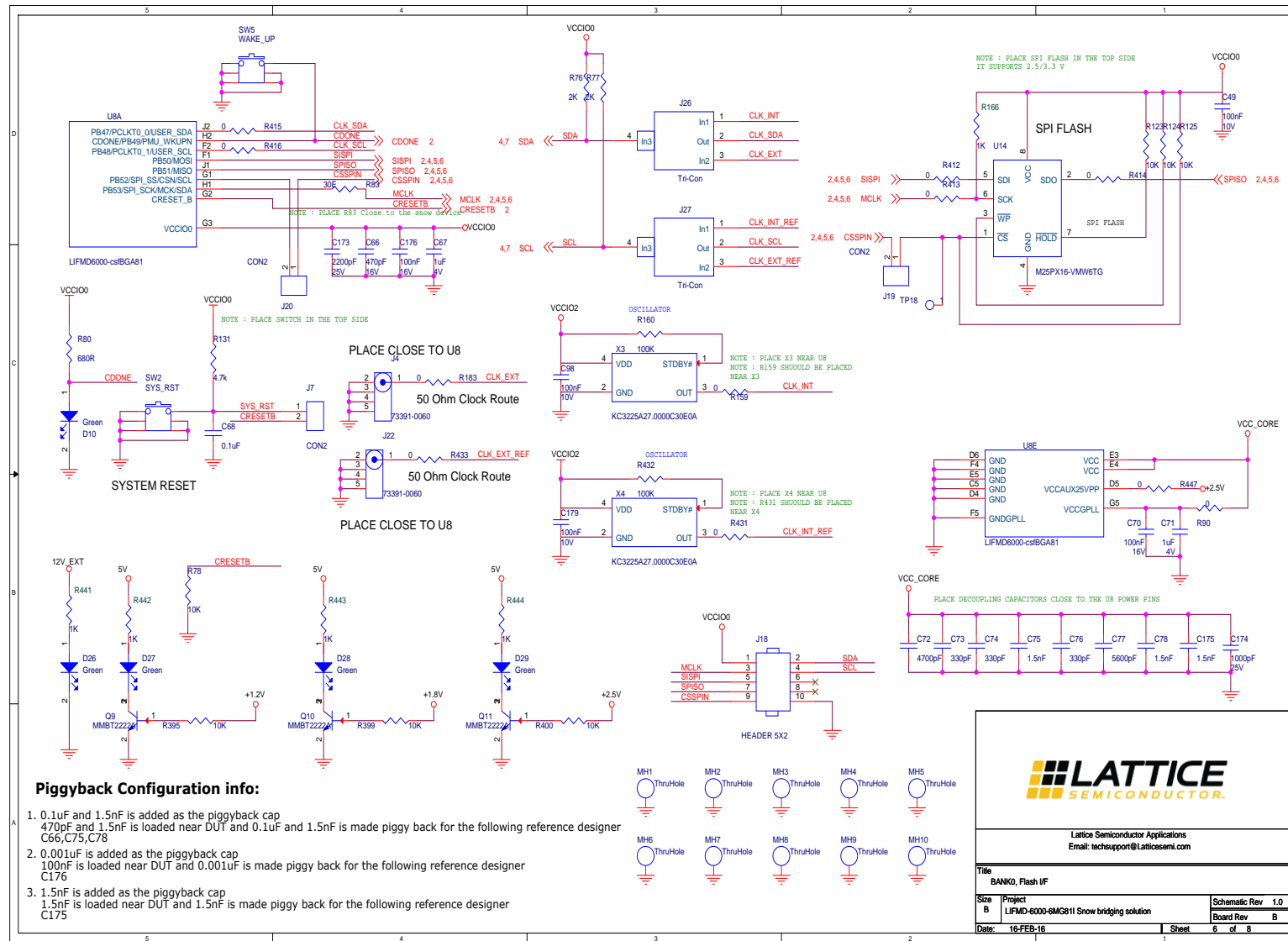

Figure A.6. Bank0, Flash Interface

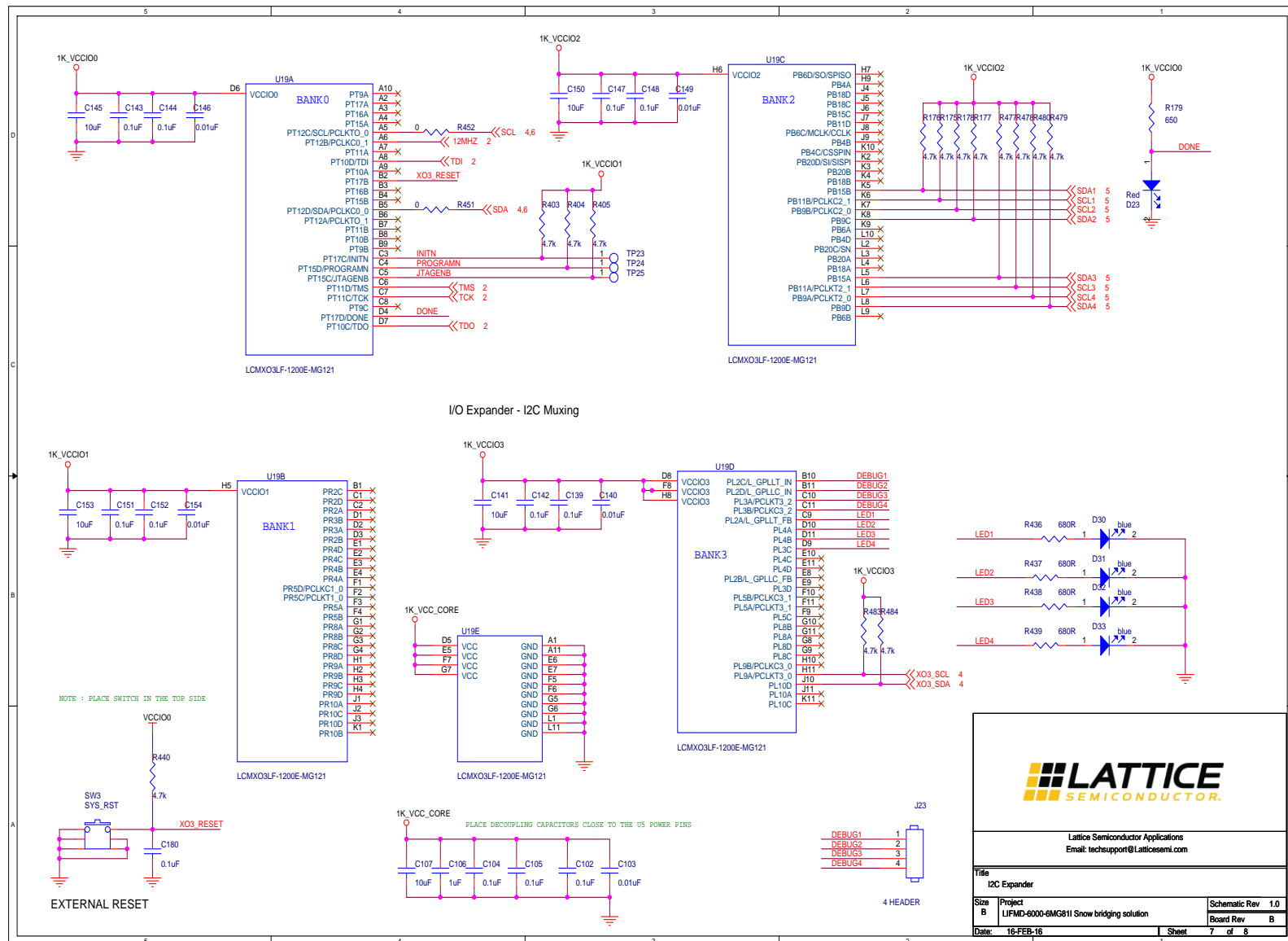



Figure A.7. I²C Expander

	5	4	3	2	1	
D	<p>Routing guidelines for MIPI & LVDS -----</p> <p>1) All differential routes are required to have the same length between the positive (true) and the negative (complimentary) routes. Spacing between the positive (true) and the negative (complimentary) shall be 2 times trace width.</p> <p>2) Target differential impedance shall be 100 Ohms</p> <p>3) Trace length matching to be within 1.0 mm (40 mil) across the entire bus.</p> <p>4) Use small humps for skew corrections</p> <p>5) Place signal vias close together and remove copper in between vias. Traces to be fully shielded with GND stitching terminating at both trace end points</p> <p>6) Board trace impedance results must be within ± 10 percent of target and Power plane impedance to be within ± 10 percent of target at operating frequency</p> <p>MIPI & LVDS Simulation Requirement -----</p> <p>1) MIPI Differential Mode insertion Loss shall be > -1.6dB at 750 MHz</p> <p>2) MIPI Differential Mode Return Loss shall be < -15dB at 750 MHz</p> <p>3) MIPI Common Mode Return Loss shall be < -15dB at 750 MHz</p> <p>4) LVDS differential mode return loss shall be < -16.5db at 600 MHz</p> <p>5) LVDS common mode return loss shall be < -16.5db at 600 MHz</p> <p>6) LVDS insertion loss shall be > -1.7db at 600 MHz</p> <p>7) LVDS Cross coupling shall be < -22 dB for victim IO at 600MHz</p> <p>8) Power plane impedance to be within ± 10 percent of target at operating frequency</p>					C
B						B
A						A
5	4	3	2	1	1	



Lattice Semiconductor Applications
Email: techsupport@Latticesemi.com

Title Layout Guidelines			
Size B	Project LIFMD-6000-6MG811 Snow bridging solution	Schematic Rev 1.0	Board Rev B
Date 16-FEB-16	Sheet 1		8 of 8

Figure A.8. Layout Guidelines

Appendix B. LIF-MD6000-ML-EVN-BRD Bill of Materials

LIF-MD6000 Master Link Rev B Board Bill of Materials

Item	Reference	Quantity	Part	PCB Footprint	Comments	PART_NUMBER	Manufacturer	Description
1	C1, C3	2	4u7	C0603	—	ECJ-1VB0J475K	Panasonic	Cap Cer 4.7 μ F 6.3 V 10% X5R 0603
2	C2, C4, C5, C6, C8, C9, C12, C13, C14, C15, C16, C22, C25, C68, C112, C180, C181	17	0.1 μ F	C0402	—	C0402C104K4RA CTU	Kemet	CAP CERAMIC 0.1 μ F 16 V X7R 0402
3	C7, C20, C23, C107, C114, C141, C145, C150, C153	9	10 μ F	C0603	—	LMK107BJ106M ALTD	Taiyo Yuden	CAP CECAP CER 10 μ F 10 V X5R 20% 0603
4	C10, C11	2	18 pF	C0402	—	C0402C180K3GA CTU	Kemet	CAP CER 18 pF 25 V C0G 0402
5	C21, C24, C113	3	22 μ F	C0805	—	LMK212BJ226M G-T	Taiyo Yuden	CAP CERAMIC 22 μ F 10 V X5R 0805
6	C29, C95, C97	3	0.1 μ F	C0402	—	CL05A104MP5N NNC	Samsung	Cap Ceramic 0.1 μ F 10 V X5R 20% SMD 0402 85C Paper T/R
7	C41, C43, C53, C60, C67, C71	6	1 μ F	C0306	—	LLR185C70G105 ME05L	Murata	CAP CER 1 μ F 4 V X7S 0306
8	C42, C44	2	0.01 μ F	C0201	—	GRM033R61C10 3KA12D	Murata	CAP CER 10000 pF 16 V X5R 0201
9	C42, C44, C51, C176	4	0.001 μ F	C0201	Piggyback Configuration	GRM033R71C10 2KA01D	Murata	CAP CER 1000 pF 16 V X7R 0201
10	C45	1	1 μ F	C0402	—	GRM155R61C10 5KA12D	Murata	CAP CER 1 μ F 16 V X5R 0402
11	C46, C66, C171, C172, C177	5	470 pF	C0201	—	GRM033R71C47 1KA01D	Murata	CAP CER 470 pF 16 V X7R 0201
12	C46, C66, C171, C172	4	0.1 μ F	C0201	Piggyback Configuration	GRM033R61C10 4KE84D	Murata	CAP CER 0.1 μ F 16 V X5R 0201

Item	Reference	Quantity	Part	PCB Footprint	Comments	PART_NUMBER	Manufacturer	Description
13	C49, C98, C179	3	100 nF	C0402	—	GRM155R61A10 4KA01D	Murata	CAP CER 100 nF 10 V 10% X5R 0402
14	C51, C58, C70, C176	4	100 nF	C0201	—	C0603X5R1C104 K030BC	TDK	CAP CER 0.1 μ F 16 V X5R 0201
15	C52	1	6800 pF	C0201	—	GRM033R71A68 2KA01D	Murata	CAP CER 6800 pF 10 V X7R 0201
16	C59, C75, C78, C175	4	1.5 nF	C0201	—	GRM033R71A15 2KA01D	Murata	CAP CER 1500 pF 10 V X7R 0201
17	C75, C78, C59, C175	4	1.5 nF	C0201	Piggyback Configuration	GRM033R71A15 2KA01D	Murata	CAP CER 1500 pF 10 V X7R 0201
18	C72	1	4700 pF	C0306	—	LLL185R71H472 MA01L	Murata	CAP CER 4700 pF 50 V X7R 0306
19	C73, C74, C76	3	330 pF	C0201	—	GRM033R71H33 1KA12D	Murata	CAP CER 330 pF 50 V X7R 0201
20	C77	1	5600 pF	C0201	—	GRM033R71A56 2KA01D	Murata	CAP CER 5600 pF 10 V X7R 0201
21	C94, C96	2	10 μ F	C0603	—	CL10X106MP8N RNC	Samsung	CAP CER 10 μ F 10 V 20% X6S 0603
22	C102, C104, C105, C139, C142, C143, C144, C147, C148, C151, C152	11	0.1 μ F	C0201	---	C0603X5R1C104 K030BC	TDK	CAP CER 0.1 μ F 16 V 10% X5R 0201
23	C103, C140, C146, C149, C154	5	0.01 μ F	C0201	—	CC0201KRX7R7B B103	Yageo	CAP CER 10000 pF 16 V 10% X7R 0201
24	C106	1	1 μ F	C0402	—	C0402C105K9PA CTU	Kemet	CAP CERAMIC 1 μ F 6.3 V X5R 0402
25	C115, C130	2	10 μ F	C0603	—	CL10A106MA8N RNC	Samsung	CAP CER 10 μ F 25 V 20% X5R 0603
26	C123	1	0.1 μ F	C0603	—	GRM188R71E10 4KA01D	Murata	CAP CER 0.1 μ F 25 V 10% X7R 0603
27	C127	1	680 pF	C0603	—	C0603C681J3GA CTU	Kemet	CAP CER 680 pF 25 V 5% NP0 0603

Item	Reference	Quantity	Part	PCB Footprint	Comments	PART_NUMBER	Manufacturer	Description
28	C128	1	0.47 μ F	C0402	—	CL05A474KA5NN NC	Samsung	CAP CER 0.47 μ F 25 V 10% X5R 0402
29	C129	1	47 μ F	C0805	—	C2012X5R1A476 M125AC	TDK	CAP CER 47 μ F 10 V 20% X5R 0805
30	C155, C156, C157, C158, C159, C160, C161, C162, C163, C164, C165, C166, C167, C168, C169, C170	16	0.1 μ F	C0402	—	04023C104KAT2 A	AVX	CAP CER 0.1 μ F 25 V 10% X7R 0402
31	C173	1	2200 pF	C0201	—	GRM033R71E22 2KA12D	Murata	CAP CER 2200 pF 25 V X7R 0201
32	C174	1	1000 pF	C0201	—	GRM033R61E10 2KA01D	Murata	CAP CER 1000 pF 25 V X5R 0201
33	C178	1	0.1 μ F	C0201	—	GRM033R61C10 4KE84D	Murata	CAP CER 0.1 μ F 16 V X5R 0201
34	D1, D14	2	SL44-E3/ 57T	SL44E357T	—	SL44-E3/57T	Vishay semiconductor	Schottky Diodes & Rectifiers 4.0 A 40 V
35	D3, D25, D26, D27, D28, D29	6	Green	led_0603	—	LTST-C190KGKT	LITE-On INC	LED SUPER GREEN CLEAR 0603 SMD
36	D6, D7, D8, D9, D30, D31, D32, D33	8	blue	led_0603	—	LTST-C193TBKT- 5A	LITE-On INC	Standard LEDs - SMD Blue 470 nm 28mcd 5 mA
37	D10	1	Green	led_0603	—	LG L29K-G2J1- 24-Z	OSRAM	LED SUPER GREEN CLEAR 0603 SMD
38	D12	1	0.3 VF	MBRA340T3 G	—	MBRA340T3G	ON Semi	DIODE SCHOTTKY 40 V 3 A SMA
39	D23	1	Red	led_0603	—	LTST-C193KRKT- 5A	LITE-On INC	Standard LEDs - SMD Red 631 nm 14mcd 5 mA

Item	Reference	Quantity	Part	PCB Footprint	Comments	PART_NUMBER	Manufacturer	Description
40	VCC_DPHY1, VCC_CORE1, VCCIO1, GND1, VCCIO2, GND2, GND3, GND4, GND5, 1K_VCCIO0, 1K_VCC_CORE1, 1K_VCCIO1, 1V2, 1K_VCCIO2, 1K_VCCIO3, TP18, TP23, TP24, TP25, 2V5, 3V3, 5V0, 12V0, VCCIO0	24	TP_S_40_63	tp_s_40_63	DNI	—	—	Square test point, 40 mil inner diameter, 63 mil outer diameter
41	J1	1	header_1x8	hdr_amp_87220_8_1x8_100	—	22-28-4081	Molex	CONN HEADER 8POS .100 VERT TIN
42	J2	1	SKT_MINIUSB_B_RA	skt_miniusb_b_ra	—	5075BMR-05-SM-CR	Neltron	CONN MINI USB RCPT RA TYPE B SMD
43	J3	1	PJ-032A	PJ-032A	—	PJ-032A	CUI Inc.	CON PWR JCK 2.0 X 6.5 M VERT
44	J4, J22	2	73391-0060	73391-0060	—	73391-0060	Molex	CONN SMA JACK STR 50 OHM PCB
45	J7, J19, J20	3	CON2	CON2	REGULAR 100 MIL HEADER	—	—	General 100 mils 2 Position header
46	J8, J9	2	2 Position Terminal Block_0	TERM_BLOCK_2POS_10A	—	1727010	Phoenix Contact	TERM BLOCK 2POS 3.81 mm PCB GRN
47	J18	1	HEADER 5X2	HEADER 2X5	REGULAR 100 MIL HEADER	—	—	General 100 Mils 2*5 header
48	J23	1	4 HEADER	CON4	REGULAR 100 MIL HEADER	—	—	General 100 Mils 4 Position Header
49	J24, J25, J26, J27	4	Tri-Con	TriCon	REGULAR 100 MIL HEADER	—	—	General 100 Mils Header
50	J28	1	CON6	HDR1X6	REGULAR 100 MIL HEADER	—	—	—

Item	Reference	Quantity	Part	PCB Footprint	Comments	PART_NUMBER	Manufacturer	Description
51	J29	1	CON3	HDR1X3	REGULAR 100 MIL HEADER	—	—	—
52	L1, L2, L3, L4, L5, L6, L7	7	600 Ω 500 mA	FB0603	—	BLM18AG601SN 1D	Murata	Ferrite Bead 600 Ω @100 MHz 500 mA 0603
53	L8	1	4.7 uH	MPLC0730L 4R7	—	MPLC0730L4R7	Kemet	INDUCTOR POWER 4.7 uH 20% SMD
54	MH1, MH2, MH3, MH4, MH5, MH6, MH7, MH8, MH9, MH10	10	Thru Hole	MTG125	DNL	—	—	—
55	Q9, Q10, Q11	3	MMBT2222 A	SM_ SOT23-3	—	MMBT2222A,21 5	NXP Semiconductor	TRANS NPN 40 V 0.6 A SOT23
56	R1, R2, R3, R56, R131, R175, R176, R177, R178, R403, R404, R405, R440, R445, R477, R478, R479, R480, R483, R484	20	4.7K	R0603	—	CRCW06034K70 FKEA	Vishay	RES SMD 4.7 kΩ HM 1% 1/10 W 0603
57	R4, R5, R6, R7, R15, R16, R26, R37, R39, R51, R52, R53, R90, R159, R165, R167, R180, R181, R183, R192, R431, R433, R447	23	0	R0603	—	RC0603JR-070RL	Yageo	Res 1/10 W 0.0 Ω 5% 0603
58	R9, R10	2	2K2	R0603	—	CRCW06032K20 FKEA	Vishay	RES SMD 2.2 kΩ 1% 1/10 W 0603
59	R11, R17	2	12K	R0603	—	RC0603FR- 0712KL	Yageo	RES SMD 12 kΩ 1% 1/10 W 0603
60	R12, R13, R14, R123, R124, R125	6	10K	R0603	—	RMCF0603JT10K 0	Stackpole Electronics Inc	RES SMD 10 kΩ 5% 1/10 W 0603
61	R18, R418, R419, R422, R423	5	0	R0603	DNI	RC0603JR-070RL	Yageo	Res 1/10 W 0.0 Ω 5% 0603

Item	Reference	Quantity	Part	PCB Footprint	Comments	PART_NUMBER	Manufacturer	Description
62	R19, R20, R21, R25, R28, R33, R184, R186, R188, R190, R410, R417, R434, R435, R448, R449	16	1	R0603	—	CRCW06031R00J NEAHP	Vishay/Dale	RES SMD 1 Ω 5% 1/4W 0603
63	R22, R144	2	100E	R0603	DNI	CRCW0603100R FKEAHP	Vishay / Dale	RES SMD 100 Ω 1% 1/4W 0603
64	R23	1	0	R0603	DNI	RC0603JR-070RL	Yageo	Res 1/10 W 0.0 Ω 5% 0603
65	R24, R185, R187, R189, R411	5	1	R0603	DNI	CRCW06031R00J NEAHP	Vishay/Dale	RES SMD 1 Ω 5% 1/4W 0603
66	R36, R233	2	1K	R0603	—	RC0603FR-071KL	Yageo	RES SMD 1 kΩ 1% 1/10 W 0603
67	R54, R55, R57, R59	4	680R	R0402	DNI	RMCF0402JT680 R	Stackpole Electronics Inc	RES 680 Ω 1/16 W 5% 0402
68	R60, R61, R446, R457, R458, R459, R460, R461, R462, R463, R464, R467, R468, R469, R470, R471, R472, R473, R474, R475, R476	21	0	R0402	—	RC0402JR-070RL	Yageo	RES SMD 0.00 HM JUMPER 1/16 W 0402
69	R76, R77	2	2K	R0402	—	ERJ-2RKF2001X	Panasonic	RES SMD 2 kΩ 1% 1/10 W 0402
70	R78	1	10K	R0402	—	RMCF0402JT10K 0	Stackpole Electronics Inc	RES 10 kΩ 1/16 W 5% 0402
71	R80, R436, R437, R438, R439	5	680R	R0402	—	RMCF0402JT680 R	Stackpole Electronics Inc	RES 680 Ω 1/16 W 5% 0402
72	R83	1	30E	R0603	—	RC0603FR- 0730RL	Yageo	RES SMD 30 Ω 1% 1/10 W 0603
73	R106, R107, R108, R110, R111, R113, R114, R117, R119, R121	10	100	R0402	DNI	RC0402FR- 07100RL	Yageo	RES SMD 100 Ω 1% 1/16 W 0402
74	R160, R432	2	100K	R0402	—	RMCF0402JT100 K	Stackpole Electronics Inc	RES 100 kΩ 1/16 W 5% 0402

Item	Reference	Quantity	Part	PCB Footprint	Comments	PART_NUMBER	Manufacturer	Description
75	R166, R441, R442, R443, R444	5	1K	R0402	—	RMCF0402JT1K00	Stackpole Electronics Inc	RES 1 kΩ 1/16 W 5% 0402
76	R179	1	650	R0603	—	RC0603FR-07649RL	Yageo	RES SMD 649 Ω 1% 1/10 W 0603
77	R229	1	15K	R0402	—	ERJ-2RKF1502X	Panasonic	RES 15 kΩ 1/10 W 1% 0402 SMD
78	R230	1	34K	R0402	—	ERJ-2RKF3402X	Panasonic	RES 34 kΩ 1/10 W 1% 0402 SMD
79	R231	1	536K	R0402	—	ERJ-2RKF5363X	Panasonic Electronic Components	RES 536 kΩ 1/10 W 1% 0402 SMD
80	R232	1	100K	R0402	—	ERJ-2RKF1003X	Panasonic Electronic Components	RES 100 kΩ 1/10 W 1% 0402 SMD
81	R395, R399, R400	3	10K	R0603	—	ERJ-3EKF1002V	Panasonic	RES SMD 10 kΩ 1% 1/10 W 0603
82	R412, R413, R414, R415, R416, R420, R421, R424, R425, R451, R452, R453, R454, R455, R456, R465, R466	17	0	R0603	—	RC0603JR-070RL	Yageo	Res 1/10 W 0.0 Ω 5% 0603
83	R450	1	0	R0402	DNI	RC0402JR-070RL	Yageo	RES SMD 0.00 HM JUMPER 1/16 W 0402
84	R481, R482	2	0	R0603	DNL	RC0603JR-070RL	Yageo	Res 1/10 W 0.0 Ω 5% 0603
85	SW1	1	PWR	TS01CQE_s witch	—	TS01CQE	C&K Components	SWITCH SLIDE SPDT 3 A 120 V
86	SW2, SW3, SW4	3	SYS_RST	2psmd_eswitch	—	TL1015AF160QG	E-Switch	SWITCH TACTILE SPST-NO 0.05 A 12 V
87	SW5	1	WAKE_UP	2psmd_eswitch	—	TL1015AF160QG	E-Switch	SWITCH TACTILE SPST-NO 0.05 A 12 V

Item	Reference	Quantity	Part	PCB Footprint	Comments	PART_NUMBER	Manufacturer	Description
88	U1	1	FT2232HL	tqfp64_0p5_12p2x12p2_h1p6	—	FT2232HL	FTDI	USB to UART / FIFO
89	U2	1	93LC56-SO8	so8_50_244	—	93LC56C-I/SN	Microchip	IC 93LC56 EEPROM
90	U3	1	FUSE	0154004DR T	—	0154004.DRT	Littlefuse	Surface Mount Fuses Fuseblock with fuse 4A OMNI BLOK 154T
91	U5	1	NCP1117ST33T3G	sot223_4p	—	NCP1117ST33T3G	On Semi	IC Reg LDO 3.3 V SOT-223
92	U6	1	NCP1117ST25T3G	sot223_4p	—	NCP1117ST25T3G	On Semi	IC Reg LDO 2.5 V SOT-223
93	U7, U9, U11, U12	4	Hirose - FX12 - 40 Pos	Hirose-FX12	—	FX12B-40P-0.4SV	Hirose Electric Co Ltd	Conn Board to Board PL 40 POS 0.4 mm Solder ST SMD T/R
94	U8	1	LIF-MD6000-csfBGA81	LIF-MD6000-csfBGA81	Customer supplied	LIF-MD6000-csfBGA81	Lattice Semiconductor	Lattice Semiconductor 6K CrossLink FPGA Family
95	U14	1	M25PX16-VMW6TG	SOIC8	—	M25PX16-VMW6TG	Micron Technology Inc	IC FLASH 16 Mbit 75 MHz 8SO
96	U15	1	AP7313-12SAG-7	SOT23	—	AP7313-12SAG-7	Diodes Inc	LDO Voltage Regulators LDO SOT-23R 1.2 V/ 150 mA
97	U17	1	NCP1117ST18T3G	sot223_4p	—	NCP1117ST18T3G	On Semi	IC Reg LDO 1.8 V SOT-223
98	U18	1	LT3680	LT3680_10QFN	—	LT3680EDD#PBF	Linear	5 V Step down converter
99	U19	1	LCMXO3LF-1200E-MG121	LCMXO3LF-1200E-MG121	Customer supplied	LCMXO3LF-1200E-MG121	Lattice Semiconductor	CPLD MachXO3 Family 121-Pin CSFBGA- 0.5 mm Pitch
100	X1	1	12MHZ	crystal_4p_3p2x2p5	—	7M-12.000MAAJ-T	TXC	12 MHz Crystal

Item	Reference	Quantity	Part	PCB Footprint	Comments	PART_NUMBER	Manufacturer	Description
101	X3, X4	2	KC3225A27. 0000C30E0A	27MHZ_OSC	—	KC3225A27.0000 C30E0A	AVX Corporation	Standard Clock Oscillators 27.000 MHz
102	LIF-MD6000 MASTER LINK REV B BOARD PCB	1	—	—	—	305-PD-16-0154	PACTRON	—

Appendix C. SMA-IOL-EVN-BRD Schematics

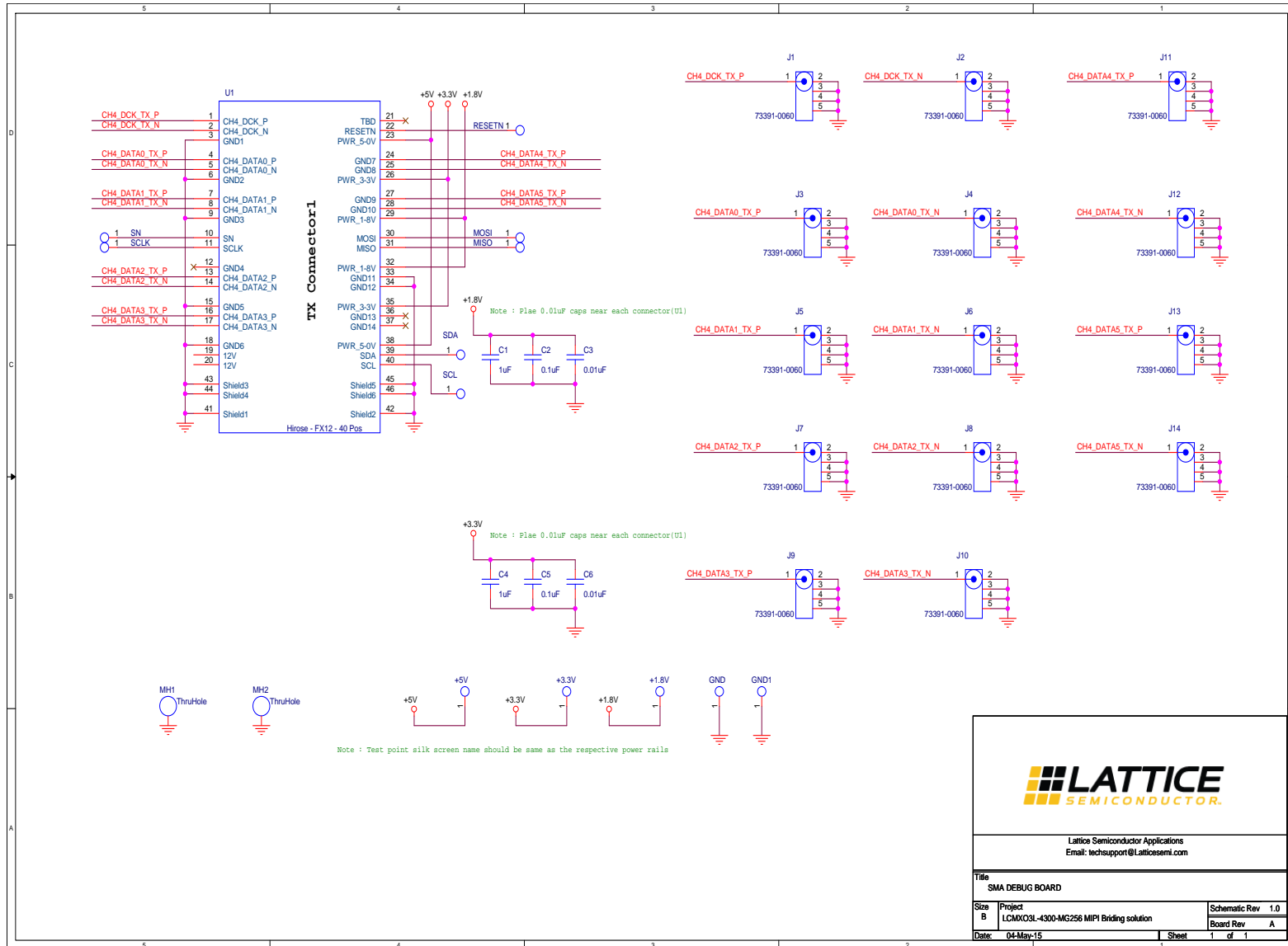

Figure C.1. SMA Debug Board

Appendix D. SMA-IOL-EVN-BRD Bill of Materials

SMA I/O Link Board Bill of Materials

Item	Reference	Qty	Part	PCB Footprint	Comments	PART_NUMBER	Manufacturer	Description
1	GND1, +5 V, +1.8 V, +3.3 V, SN, SDA, SCLK, SCL, RESETN, MOSI, MISO, GND	12	TP_S_40_63	tp_s_40_63	DNI	—	—	Square test point, 40 mil inner diameter, 63 mil outer diameter
2	C1, C4	2	1 μ F	C0402	—	C0402C105K9PACTU	Kemet	CAP CERAMIC 1 μ F 6.3 V X5R 0402
3	C2, C5	2	0.1 μ F	C0402	—	C0402C104K4RACTU	Kemet	CAP CERAMIC 0.1 μ F 16 V X7R 0402
4	C3, C6	2	0.01 μ F	C0402	—	C0402C103J4RACTU	Kemet	CAP CERAMIC 10 nF 16 V 5% X7R 0402
5	J1, J2, J3, J4, J5, J6, J7, J8, J9, J10, J11, J12, J13, J14	14	73391-0060	73391-0060	—	73391-0060	Molex	Molex Straight 500 Through Hole SMA Connector, jack, Solder Termination
6	MH1, MH2	2	Thru Hole	MTG125	—	—	—	—
7	U1	1	Hirose - FX12 - 40 Pos	Hirose-FX12S	—	FX12B-40S-0.4SV	Hirose Electric Co Ltd	Conn Board to Board PL 40 POS 0.4 mm Solder ST SMD T/R
8	SMA IOLINK BOARD PCB	1	—	—	—	305-PD-15-0589	PACTRON	—

Appendix E. B-IOL-EVN-BRD Schematics

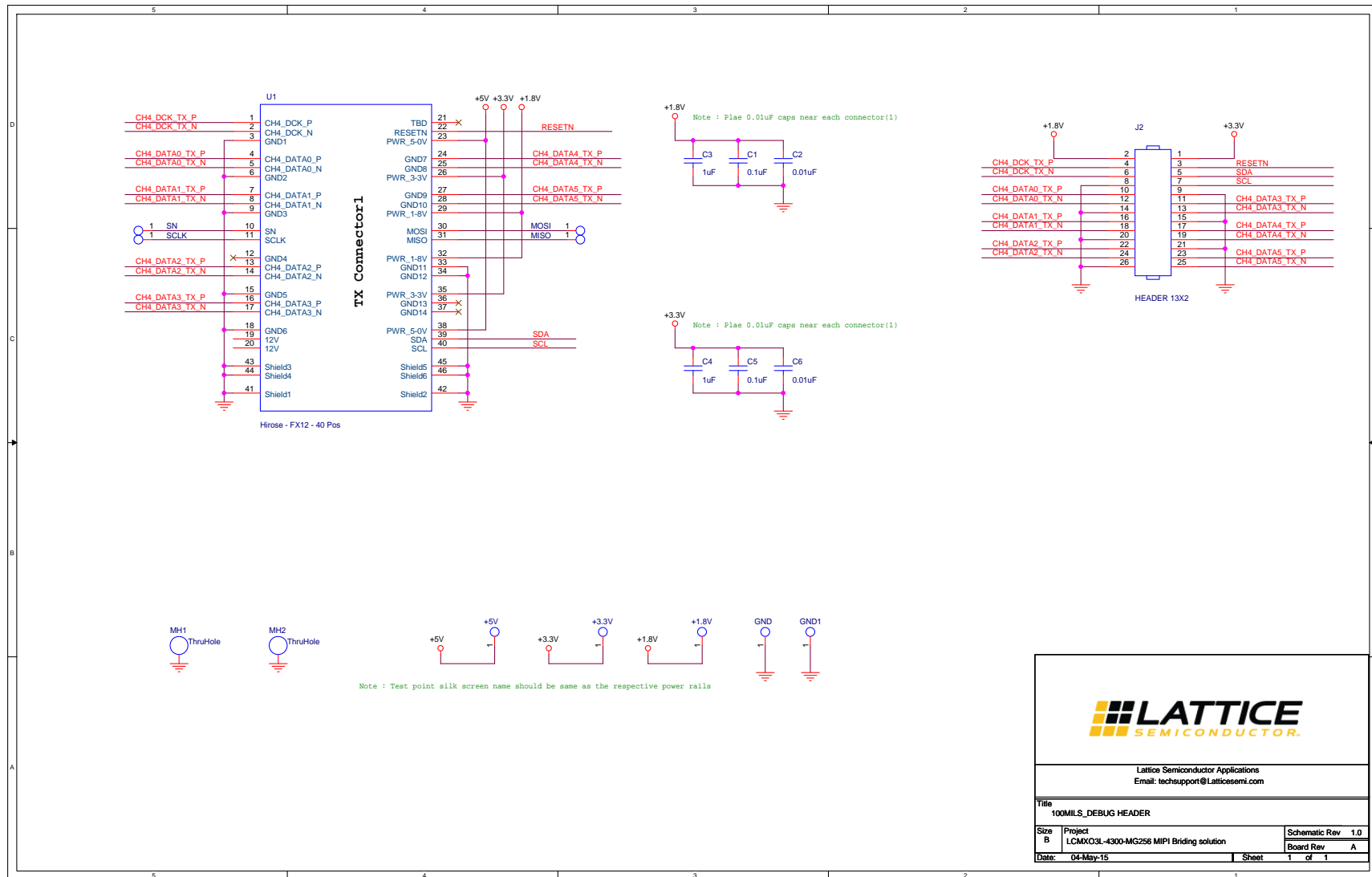

Figure E.1. 100MILS_DEBUG Header

Appendix F. B-IOL-EVN-BRD Bill of Materials

Breakout I/O Link Board Bill of Materials

Item	Reference	Qty	Part	PCB Footprint	Comments	PART_NUMBER	Manufacturer	Description
1	GND1, +5 V, +1.8 V, +3.3 V, SN, SCLK, MOSI, MISO, GND	9	TP_S_40_63	tp_s_40_63	DNL	—	—	Square test point, 40 mil inner diameter, 63 mil outer diameter
2	C1, C5	2	0.1 μ F	C0402	—	C0402C104K4RACTU	Kemet	CAP CERAMIC 0.1 μ F 16 V X7R 0402
3	C2, C6	2	0.01 μ F	C0402	—	C0402C103J4RACTU	Kemet	CAP CERAMIC 10 nF 16 V 5% X7R 0402
4	C3, C4	2	1 μ F	C0402	—	C0402C105K9PACTU	Kemet	CAP CERAMIC 1 μ F 6.3 V X5R 0402
5	J2	1	HEADER 13X2	13X2_HDR	REGULAR 100 MIL HEADER	—	—	—
6	MH1, MH2	2	ThruHole	MTG125	DNL	—	—	—
7	U1	1	Hirose - FX12 - 40 Pos	Hirose-FX12S	—	FX12B-40S-0.4SV	Hirose Electric Co Ltd	Conn Board to Board PL 40 POS 0.4 mm Solder ST SMD T/R
8	BREAKOUT IOLINK BOARD PCB	1	—	—	—	305-PD-15-0595	PACTRON	—

References

For more information, refer to FPGA-DS-02007 (previously DS1055), [CrossLink Family Data Sheet](#).

Technical Support Assistance

Submit a technical support case through www.latticesemi.com/techsupport.

Revision History

Revision 1.6, September 2021

Section	Change Summary
All	<ul style="list-style-type: none"> Minor adjustments in formatting across the document. Updated last page of the document.
Disclaimers	Added this section.
Breakout I/O Link Board	Updated Table 7.2 to change Name column to Connector Pin Name and add Net Name column.
Revision History	Updated table to new template.

Revision 1.5, June 2018

Section	Change Summary
All	<ul style="list-style-type: none"> Changed document name to CrossLink LIF-MD6000 Master Link Board - Revision B Evaluation Board User Guide. Specified Rev B in all references to the board.
Headers and Test Connections	Updated Table 2.1 .
Programming Circuit	Corrected device name to MachXO3 LCMXO3LF-1300E.
Power Supply	Updated this section.
Revision History	Updated table to new template.

Revision 1.4 April 2018

Section	Change Summary
Appendix A. LIF-MD6000-ML-EVN-BRD Schematics	Made schematics searchable.

Revision 1.3 March 2018

Section	Change Summary
Headers and Test Connections	Added footnote in Table 2.1 .

Revision 1.2 September 2017

Section	Change Summary
All	Changed document number from EB105 to FPGA-EB-02010.
Headers and Test Connections	Changed J25 from VCCIO1 to VCCIO2 in Table 2.1 .
Appendix E. B-IOL-EVN-BRD Schematics	Updated 100MILS_DEBUG header.

Revision 1.1, April 2017

Section	Change Summary
SMA I/O Link Board	Added this section.
Breakout I/O Link Board	Added this section.
Ordering Information	Added this section.
Appendix A. LIF-MD6000-ML-EVN-BRD Schematics	<ul style="list-style-type: none"> Changed "SW4 SYS_RST" to "SW4 EXT_RST" in the Bank 1, 2 – LVDS Rx diagram. Changed "EXTERNAL RESET" to "SYSTEM RESET" in the Bank0, Flash Interface diagram.

Revision 1.0, May 2016

Section	Change Summary
All	First release.



www.latticesemi.com