

FEATURES

Combined gyroscope and dual-axis, low g accelerometer
Temperature compensated, high precision bias, and sensitivity performance
 ± 30 mg accelerometer bias stability over temperature
 $\pm 2^\circ/\text{sec}$ gyroscope null stability over temperature
2.5 mg rms typical accelerometer noise at 35.6 Hz
 $0.1^\circ/\text{sec}$ rms typical gyroscope noise at 35.6 Hz
Gyroscope: linear acceleration rejection of $0.03^\circ/\text{sec}/g$
Acceleration: ± 32 g overload performance
SPI digital output with a 16-bit data-word and a 4-bit CRC
Comprehensive electromechanical fail-safe features
6 kHz data update rate
Programmable filter response
<16 mA quiescent current draw
3.3 V or 5 V operation
 -40°C to $+105^\circ\text{C}$ temperature range
16-lead inverted cavity SOIC package for robust EMI performance
Qualified for automotive applications

APPLICATIONS

Electronic stability control
Chassis control

GENERAL DESCRIPTION

The **ADXC1500** is a yaw rate gyroscope and dual-axis accelerometer combined in a single package. It is designed for electronic stability control (ESC) and other high performance applications that require yaw rate and acceleration signals simultaneously. An internal temperature sensor compensates offset and sensitivity performance, providing excellent stability over the -40°C to $+105^\circ\text{C}$ temperature range.

A digital serial port interface (SPI) transmits the yaw rate and acceleration data to a host microcontroller. A 4-bit cyclical redundancy check (CRC) provides fault coverage for the transmitted SPI data, and internal fault detection routines ensure the integrity of all reported yaw rates and acceleration data. A fully integrated electromechanical continuous self test (CST) routine provides run-time diagnostic capability for assessing the health of each MEMS element.

An advanced gyroscope sensor design rejects the linear acceleration effects of shock and vibration, enabling the **ADXC1500** to operate in harsh environments. The accelerometer signal chain is designed to prevent overload conditions from occurring in these same harsh environments.

The **ADXC1500** is designed to operate at either 3.3 V or 5 V. At less than 16 mA current consumption, the **ADXC1500** can be used in energy sensitive applications.

FUNCTIONAL BLOCK DIAGRAM

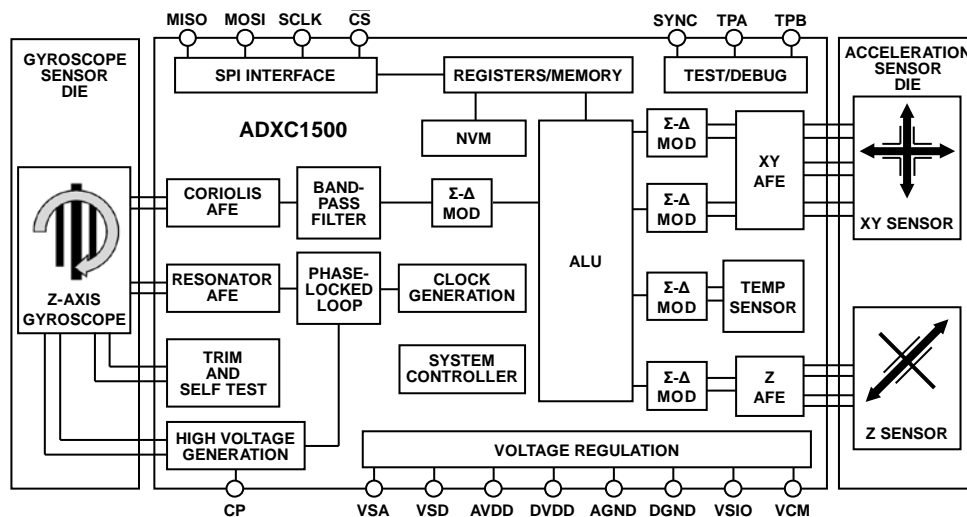

Figure 1.

For more information about the **ADXC1500**, contact the Analog Devices, Inc., *Customer Interaction Center* at http://www.analog.com/technical_support to connect with a technical support specialist.

Rev. SpB

[Document Feedback](#)

Information furnished by Analog Devices is believed to be accurate and reliable. However, no responsibility is assumed by Analog Devices for its use, nor for any infringements of patents or other rights of third parties that may result from its use. Specifications subject to change without notice. No license is granted by implication or otherwise under any patent or patent rights of Analog Devices. Trademarks and registered trademarks are the property of their respective owners.

One Technology Way, P.O. Box 9106, Norwood, MA 02062-9106, U.S.A.
 Tel: 781.329.4700 ©2016–2017 Analog Devices, Inc. All rights reserved.
[Technical Support](#) www.analog.com

ADXC1500* PRODUCT PAGE QUICK LINKS

Last Content Update: 04/07/2017

COMPARABLE PARTS

View a parametric search of comparable parts.

DOCUMENTATION

Data Sheet

- ADXC1500: Combined Gyroscope and Dual-Axis Accelerometer Data Sheet

REFERENCE MATERIALS

Press

- Integrated Accelerometer/Gyro Combo Series from Analog Devices Helps Improve Reliability and Accuracy of Automotive Safety Systems

DESIGN RESOURCES

- ADXC1500 Material Declaration
- PCN-PDN Information
- Quality And Reliability
- Symbols and Footprints

DISCUSSIONS

View all ADXC1500 EngineerZone Discussions.

SAMPLE AND BUY

Visit the product page to see pricing options.

TECHNICAL SUPPORT

Submit a technical question or find your regional support number.

DOCUMENT FEEDBACK

Submit feedback for this data sheet.

NOTES