

MOSFETs





COMPANY OVERVIEW

DIODES INCORPORATED'S PRODUCTS ARE DESIGNED FOR HIGH PERFORMANCE ACROSS A WIDE RANGE OF EXISTING AND EMERGING APPLICATIONS

Diodes Incorporated is a leading global provider of Discrete, Analog, and Logic semiconductors.

Its global footprint includes sales offices in 5 countries and manufacturing locations in China, Europe and the USA.

A focus on product innovation, cost reduction, acquisitions and customer service has made Diodes Incorporated an industry leader.

Combining leading silicon and packaging technologies, Diodes provides a broad portfolio of discrete semiconductors comprising Bipolar Transistors, MOSFETs, Schottky diodes, SBR®, switching diodes and functional specific arrays to enable our customers' next generation designs.

The Diodes' Analog IC portfolio consists of 6 main areas: Power Management, Standard Linear, Lighting, Sensors, Direct Broadcast by Satellite, and Applications Specific Standard Products. Diodes' IC portfolio also includes Standard Logic products.

SBR and PowerDI are registered trademarks of Diodes Incorporated.



THE LEADING EDGE... MOSFETS

A FOCUS ON PRODUCT INNOVATION DRIVEN BY CUSTOMER REQUIREMENTS HAS RESULTED IN LEADING-EDGE MOSFETS...

Encompassing N- and P-channels, the portfolio ranges from 8V to 650V packaged in single, dual, complementary and H-Bridge (Quad) configurations. These are offered in a wide range of package options from the tiny DFN0606 to the thermally-efficient PowerDI®5060 (Power SO-8) and through-hole TO220 packages. With innovations in chip-scale packaging to enable the lowest $R_{DS(ON)}$ for a given footprint.

Embracing both industry-standard and differentiated products, the broad portfolio has expanded to over 800 products from small-signal to power MOSFETs. Diodes Incorporated utilizes emerging technologies that are uniquely suited for specific applications, such as using shield-gate technology to reduce conduction and switching losses, which is ideal for BLDC motor driving. Diodes' lateral MOSFETs (LD-MOS) feature industry-leading Figure of Merit (FOM), which enables greater efficiency in DC-DC buck converters.

The breadth of the Diodes' MOSFET portfolio enables designers to select a device that is optimized for their end application, ranging from consumer to industrial to automotive segments.

The Diodes portfolio is well suited for meeting the circuit requirements in:

- DC-DC Conversion
- Motor Control
- LED Lighting
- Battery Protection
- Load Switching
- Power Supplies
- Battery Chargers
- Audio Circuits
- Power-Over-Ethernet

The majority of products in the Diodes MOSFET product portfolio are designed to meet the stringent requirements of AEC-Q101 reliability standard of the Automotive Electronic Council.

Products with a 'Q' suffix indicate that the product is Automotive grade - the device has passed the rigorous AEC-Q101 standard and is fully supported for Automotive customers with PPAP (Production Part Approval Process), and TS16949 approved manufacturing sites. Furthermore, all in-house packaging utilizes environmentally 'green' mold compound.

Diodes Incorporated's MOSFET product development strategy is focused on high growth market segments such as Automotive, LED Lighting, Ethernet, Smartphones, and the Internet of Things.



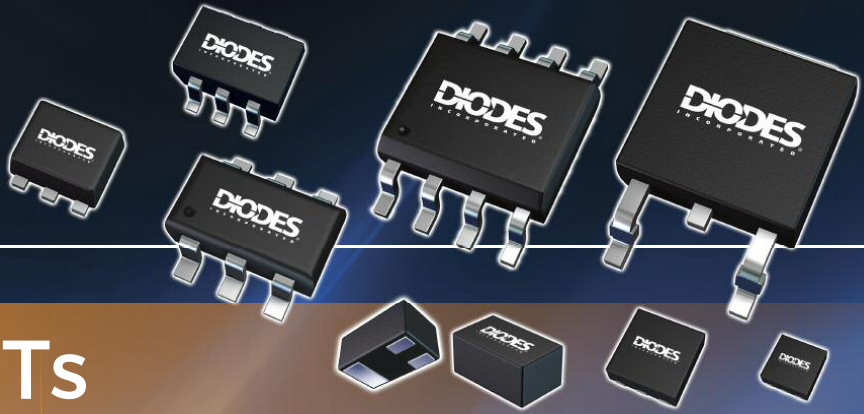

MOSFETs



INDEX

8V - 29V N-CHANNEL	4-6
8V - 29V P-CHANNEL	6-8
8V - 29V COMPLEMENTARY	9
DUAL, COMMON-SOURCE / DRAIN	10
30V N-CHANNEL	11-13
30V P-CHANNEL	13-14
30V COMPLEMENTARY	15
31V - 50V N-CHANNEL	16
31V - 50V P-CHANNEL	17
31V - 100V COMPLEMENTARY	18
51V - 99V N-CHANNEL	19-20
51V - 99V P-CHANNEL	21
100V PLUS N-CHANNEL	22-23
100V PLUS P-CHANNEL	23
PROTECTED MOSFETS	24
H-BRIDGE	25
HIGH TEMPERATURE AUTO FETS	26
MOSFET PACKAGE EVOLUTION	27

8V – 29V N-CHANNEL



Part Number	Configuration	ESD Diode (Y/N)	V _{DS} (V)	V _{GS} (±V)	I _{DS} (A)	P _D (W)	R _{DS(ON)} (mΩ max) at V _{GS} =			V _{GS} (th) (V)		C _{ISS} typ @ V _{GS} =½V _{DSS} (pF)	Q _C typ @ V _{GS} = 4.5V (nC)	Package
					@T _A =25°C	@T _A =25°C	4.5V	2.5V	1.8V	Min.	Max.			
DMN1019UFDE	Single	Yes	12	8	11	0.69	10	12	14	0.35	0.8	2480	27.3	U-DFN2020-6 Type E
DMN1019USN	Single	Yes	12	8	9.3	0.68	10	12	14	0.35	0.8	2480	27.3	SC59
DMN1025UFDB	Dual	Yes	12	10	6.9	1.7	25	30	38	0.4	1	917	12.6	U-DFN2020-6 Type B
DMN1032UCB4	Single	No	12	8	4.8	1.16	26	29	38	0.4	1.2	325	3.2	U-WLB1010-4
DMN1029UFDB	Dual	No	12	8	5.6	1.4	29	34	44	0.4	1	914	10.5	U-DFN2020-6 Type B
DMN1045UFR4	Single	Yes	12	8	3.2	0.5	45	64	85	0.4	1	390	4.8	X2-DFN1010-3
DMN1150UFB	Single	Yes	12	6	1.4	0.5	150	185	210	0.35	1	110	1.5	X1-DFN1006-3
DMN1260UFA	Single	Yes	12	8	0.5	0.36	366	520	950	0.4	1	65	0.96	X2-DFN0806-3
DMN2005UFG	Single	No	20	12	18.1	1.05	4.6	8.7	-	0.4	1.2	6495	68.8	POWERDI3333-8
DMN2009LSS	Single	No	20	12	12	2	9	12	-	0.5	1.2	2555	28.9	SO-8
DMN2011UFDE	Single	Yes	20	12	11.7	1.97	9.5	11	20	0.4	1	2248	24	U-DFN2020-6 Type E
DMN2013UFDE	Single	Yes	20	8	10.5	0.66	11	13	-	0.5	1.1	2453	14.3	U-DFN2020-6 Type E
DMN2015UFDE	Single	Yes	20	12	10.5	2.03	11.6	15	30	0.5	1.1	1779	19.7	U-DFN2020-6 Type E
DMN2027USS	Single	No	20	12	10.5	1.5	12.5	19	-	0.7	1.3	1000	11.6	SO-8
DMN2020UFCL	Single	Yes	20	10	9	0.61	14	20	26	0.4	0.9	1788	21.5	X1-DFN1616-6 Type E
DMG6898LSD	Dual	Yes	20	12	9.5	1.28	16	23	-	0.5	1.5	1149	11.6	SO-8
DMN2020LSN	Single	Yes	20	12	6.9	0.61	20	28	-	0.5	1.5	1149	11.6	SC59
DMN2028USS	Single	Yes	20	12	9.8	2.8	20	28	-	0.6	1.3	1000	11.6	SO-8
DMN2022UFDF	Single	Yes	20	8	7.9	0.66	22	26	36	0.5	1	907	9.8	U-DFN2020-6
DMG9926USD	Dual	No	20	8	8	1.3	24	29	37	0.5	0.9	880	8.8	SO-8
DMG3414U	Single	No	20	8	4.2	0.78	25	29	37	0.5	0.9	830	9.6	SOT23
DMG6968U	Single	Yes	20	12	6.5	1.3	25	29	36	0.5	0.9	151	8.5	SOT23
DMN2029USD	Dual	No	20	8	5.8	1.4	25	35	-	0.6	1.5	1171	10.4	SO-8
DMN2041L	Single	No	20	12	6.4	0.78	28	41	-	0.5	1.2	550	7.2	SOT23
DMN2041LSD	Dual	No	20	12	7.6	1.16	28	41	-	0.5	1.2	550	7.2	SO-8
DMN2050L	Single	No	20	12	5.9	1.4	29	50	-	0.45	1.4	532	6.7	SOT23
DMG3420U	Single	No	20	12	5.5	0.74	35	48	91	0.5	1.2	435	5.4	SOT23
DMN2075U	Single	No	20	8	4.2	0.8	38	45	-	0.4	1	594	7	SOT23
DMN2041UFDB	Dual	Yes	20	12	4.7	1.4	40	65	-	0.35	1.4	713	8	U-DFN2020-6 Type B
ZXM64N02X	Single	No	20	12	5.4	1.1	40	50	-	0.7	-	1150	12.5	MSOP-8
ZXMN2B03E6	Single	No	20	8	4.3	1.1	40	55	75	0.4	1	1160	14.5	SOT26
DMN2050LFDB	Dual	No	20	12	4.5	1.42	45	55	-	0.4	1	389	5.7	U-DFN2020-6 Type B
ZXMN2F30FH	Single	No	20	12	4.1	0.96	45	65	-	0.6	1.5	452	4.8	SOT23
DMN2075UDW	Single	No	20	8	2.8	0.58	48	59	70	0.4	1	594	7	SOT363
DMN2100UDM	Single	Yes	20	8	4	1.5	55	70	90	0.6	1	555	8.8	SOT26
ZXMN2A03E6	Single	No	20	12	4.6	1.7	55	100	-	0.7	-	837	8.2	SOT26
ZXMN2B14FH	Single	No	20	8	3.5	1	55	75	100	0.4	1	872	11	SOT23
DMN2065UW	Single	No	20	12	2.8	0.7	56	65	93	0.35	1	400	5.4	SOT323
ZXMN2A14F	Single	No	20	12	3.4	1	60	110	-	0.7	-	544	6.6	SOT23
ZXMN2F34FH	Single	No	20	12	3.4	0.95	60	120	-	0.5	1.5	277	2.8	SOT23
DMN2046U	Single	Yes	20	12	3.4	1.26	72	110	-	0.4	1.4	292	3.8	SOT23
DMG2302U	Single	No	20	8	4.2	0.8	90	120	-	0.4	1	594	7	SOT23
DMN2112SN	Single	Yes	20	8	1.2	0.5	100	140	250	0.5	1.2	220	-	SC59
DMN2114SN	Single	Yes	20	12	1.2	0.5	100	160	-	0.7	1.4	180	-	SC59
DMN2215UDM	Dual	Yes	20	12	2	0.65	100	140	215	0.6	1	188	2.3	SOT26
ZXM62N02E6	Single	No	20	12	3.2	1.1	100	125	-	0.7	-	470	5	SOT26
ZXMN2B01F	Single	No	20	8	2.1	0.625	100	150	200	0.4	1	370	4.8	SOT23
DMN2230U	Single	No	20	12	2	0.6	110	145	230	0.5	1	188	2.3	SOT23
ZXMN2A01E6	Single	No	20	12	2.5	1.1	120	225	-	0.7	-	310	3.1	SOT26
ZXMN2A01F	Single	No	20	12	1.9	0.625	120	225	-	0.7	-	310	3.1	SOT23
ZXMN2AMC	Dual	No	20	12	2.9	1.5	120	300	-	0.7	-	310	3.1	W-DFN3020-8 Type B

8V – 29V N-CHANNEL (CONTINUED)



Part Number	Configuration	ESD Diode (Y/N)	V _{DS} (V)	V _{GS} (±V)	I _{DS} (A) @T _A =25°C	P _D (W) @T _A =25°C	R _{DS(ON)} (mΩ max) at V _{GS} =			V _{GS(th)} (V)		C _{ISS} typ @ V _{GS} =½V _{DSS} (pF)	Q _C typ @ V _{GS} = 4.5V (nC)	Package
							4.5V	2.5V	1.8V	Min.	Max.			
ZXMD63N02X	Dual	No	20	12	2.5	1.25	130	150	-	0.7	3	360	4.5	MSOP-8
DMN2250UFB	Single	Yes	20	8	1.4	0.5	170	230	250	0.35	1	100	1.4	X1-DFN1006-3
DMN2300U	Single	Yes	20	8	1.4	0.55	175	240	360	0.45	0.95	70	1.6	SOT23
DMN2300UFB	Single	Yes	20	8	1.3	0.47	175	240	360	0.45	0.95	70	1.6	X1-DFN1006-3
DMN2300UFB4	Single	Yes	20	8	1.3	0.5	175	240	360	0.45	0.95	70	1.6	X2-DFN1006-3
ZXM61N02F	Single	No	20	12	1.7	0.625	180	240	-	0.7	-	170	2.7	SOT23
DMN2300UFL4	Dual	Yes	20	8	2.1	1.39	195	260	380	0.45	0.95	70	1.6	X2-DFN1310-6
DMN2300UFD	Single	Yes	20	8	1.7	0.96	200	260	400	0.45	0.95	70	1.6	X1-DFN1212-3
ZXMN2088DE6	Dual	No	20	8	1.7	0.9	200	240	310	0.4	1	279	3.8	SOT26
DMG1012T	Single	Yes	20	6	0.63	0.28	400	500	700	0.5	1	61	0.74	SOT523
DMN2500UFB4	Single	Yes	20	6	0.81	0.46	400	500	700	0.5	1	62	0.74	X2-DFN1006-3
DMN2501UFB4	Single	Yes	20	8	1	0.5	400	500	700	0.5	1	88	1.1	X2-DFN1006-3
DMG1012UW	Single	Yes	20	6	1	0.29	450	600	750	0.5	1	61	0.74	SOT323
DMG1024UV	Dual	Yes	20	6	1.4	0.53	450	600	750	0.5	1	61	0.74	SOT563
DMN2550UFA	Single	Yes	20	8	0.6	0.36	450	550	750	0.4	1	54	0.88	X2-DFN0806-3
DMN2400UV	Dual	Yes	20	12	1.33	0.53	500	700	900	0.5	0.9	38	0.5	SOT563
DMN2004DMK	Dual	Yes	20	8	0.54	0.225	550	700	900	0.5	1	87	-	SOT26
DMN2004DWK	Dual	Yes	20	8	0.54	0.2	550	700	900	0.5	1	87	-	SOT363
DMN2004K	Single	Yes	20	8	0.63	0.35	550	700	900	0.5	1	87	0.9	SOT23
DMN2004TK	Single	Yes	20	8	0.54	0.15	550	700	900	0.5	1	87	-	SOT523

PROBABLY THE SMALLEST, MOST POWERFUL MOSFET IN THE WORLD....

Did you know? DFN0606 miniature MOSFETs feature a footprint measuring only 0.6mm x 0.6mm. Each device takes 40% less board space than the commonly used DFN1006 (aka SOT883) packaged MOSFETs, making it an ideal choice in next-generation wearable technology, tablets, smartphones, watches, headsets and the Internet of Things (IoT).

Able to deliver an equivalent or better electrical performance than many of the larger package parts, the DMN2990UFZ (20V N-channel), the DMN31D5UFZ (30V N-channel) and DMP32D9UFZ (30V P-channel) have been designed to minimize on-state resistance while still maintaining a superior switching performance. What's more, a typical threshold voltage of less than a volt means a lower turn-on, suiting single-cell operation, and enabling low-voltage circuits to fully enhance the MOSFET channel.

These tiny MOSFETs are as a result a good choice in high efficiency power management duties and as general purpose interfacing and simple analog switches. Circuit power density gets a boost too, with the DFN0606 parts achieving a power dissipation of 300mW. Further to this, they maintain the low profile of 0.4mm that is associated with DFN1006; making both the DFN0606 and DFN0806 packages ideal for thin profile applications.



THE DIODES ADVANTAGE

N-channel and P-channel in the tiny DFN0606, DFN0806 & DFN1006

- DFN0606 = 0.36mm² footprint with 0.4mm off-board height**
 Occupies 40% less board space than the DFN1006/SOT883 package, enabling designers to shrink designs while maintaining performance.
- Higher power density**
 These DFN leadless package is thermally efficient with a thermal resistance of only 135°C/W enabling a greater power density to be achieved.
- Turn-on V_{GS(th)} < 1V**
 These MOSFETs have V_{GS(th)} < 1V enabling low voltage applications to fully enhance the MOSFET channel under low power conditions.

8V – 29V N-CHANNEL (CONTINUED)



Part Number	Configuration	ESD Diode (Y/N)	V _{DS} (V)	V _{GS} (±V)	I _{DS} (A) @T _A =25°C	P _D (W) @T _A =25°C	R _{DS(ON)} (mΩ max) at V _{GS} =			V _{GS} (th) (V)		C _{ISS} typ @ V _{GS} =½V _{DSS} (pF)	Q _C typ @ V _{GS} = 4.5V (nC)	Package
							4.5V	2.5V	1.8V	Min.	Max.			
DMN2004VK	Dual	Yes	20	8	0.54	0.25	550	700	900	0.5	1	87	-	SOT563
DMN2004WK	Single	Yes	20	8	0.54	0.2	550	700	900	0.5	1	87	-	SOT323
DMN2400UFB	Single	Yes	20	12	0.75	0.47	550	750	900	0.5	0.9	38	0.5	X1-DFN1006-3
DMN2400UFB4	Single	Yes	20	12	0.75	0.47	550	750	900	0.5	0.9	38	0.5	X2-DFN1006-3
DMN2400UFD	Single	Yes	20	12	0.9	0.8	600	800	1000	0.45	1	38	0.5	X1-DFN1212-3
DMN21D2UFB	Single	Yes	20	12	0.76	0.9	990	1200	2400	0.4	1	29	0.47	X1-DFN1006-3
DMN2990UDJ	Dual	Yes	20	8	0.45	0.35	990	1200	1800	0.4	1	28	0.5	SOT963
DMN2990UFA	Single	Yes	20	8	0.51	0.4	990	1200	1800	0.4	1	28	0.5	X2-DFN0806-3
DMN2990UFZ	Single	Yes	20	8	0.25	0.32	990	1200	1800	0.4	1	28	0.5	X2-DFN0606-3
DMN2005DLP4K	Dual	Yes	20	10	0.3	0.4	1500	1700	3500	0.53	0.9	37	-	X2-DFN1310-6
DMN2005LP4K	Single	Yes	20	10	0.3	0.4	1500	1700	3500	0.53	0.9	37	-	X2-DFN1006-3
DMN2005LPK	Single	Yes	20	10	0.44	0.45	1500	1700	3500	0.53	0.9	37	-	X1-DFN1006-3
DMN26D0UDJ	Dual	Yes	20	10	0.24	0.3	3000	4000	6000	0.45	1.05	14.5	-	SOT963
DMN26D0UFB4	Single	Yes	20	10	0.24	0.35	3000	4000	6000	0.45	1.05	14.5	-	X2-DFN1006-3
DMN26D0OUT	Single	Yes	20	10	0.23	0.3	3000	4000	6000	0.5	1	14.5	-	SOT523
DMN2005K	Single	Yes	20	10	0.3	0.35	-	1700	3500	0.53	0.9	37	-	SOT23
DMN2600UFB	Single	Yes	25	8	1.3	0.54	350	450	600	0.45	1	75	0.85	X1-DFN1006-3
DMG301NU	Single	Yes	25	8	0.26	0.4	4000	5000	-	0.7	1.1	27.9	0.36	SOT23
DMG6301UDW	Dual	Yes	25	8	0.24	0.3	4000	5000	-	0.65	1.5	27.9	0.36	SOT363
DMN25D0UFA	Single	Yes	25	8	0.32	0.63	4000	5000	-	0.6	1.2	27.9	0.36	X2-DFN0806-3
DMN3150LW	Single	No	28	12	1.6	0.35	88	138	-	0.62	1.4	300	-	SOT323

8V – 29V P-CHANNEL



Part Number	Configuration	ESD Diode (Y/N)	V _{DS} (V)	V _{GS} (±V)	I _{DS} (A) @T _A =25°C	P _D (W) @T _A =25°C	R _{DS(ON)} (mΩ max) at V _{GS} =			V _{GS} (th) (V)		C _{ISS} typ @ V _{GS} =½V _{DSS} (pF)	Q _C typ @ V _{GS} = 4.5V (nC)	Package
							4.5V	2.5V	1.8V	Min.	Max.			
DMP1012UCB9	Single	Yes	8	6	10	1.6	10	14	-	0.4	1.1	817	8.1	U-WLB1515-9
DMP1022UFDF	Single	Yes	12	8	9.5	2.1	15.3	19	26.5	0.35	0.8	2712	28.6	U-DFN2020-6
DMP1022UFDE	Single	Yes	12	8	9.1	2	16	21.5	26	0.35	0.8	2712	28.6	U-DFN2020-6 Type E
DMP1018UCB9	Single	Yes	12	6	7.6	1.8	18	22	-	0.4	1.3	457	4.9	U-WLB1515-9
DMP1245UFCL	Single	Yes	12	8	6.6	1.7	29	45	60	0.3	0.95	1600	16.1	X1-DFN1616-6 Type E
DMP1045U	Single	Yes	12	8	5.2	1.3	31	45	75	0.3	1	1400	15.8	SOT23
DMP1045UFY4	Single	Yes	12	8	5.5	1.7	33	41	-	0.3	1	1400	14.8	X2-DFN2015-3
DMP1055UFDB	Dual	Yes	12	8	3.9	1.4	59	81	115	0.4	1	1028	13	U-DFN2020-6 Type B
DMP1046UFDB	Dual	No	12	8	3.8	1.4	61	81	115	0.4	1	915	10.7	U-DFN2020-6 Type B
DMP1080UCB4	Single	Yes	12	6	3.3	1.6	80	93	-	0.4	1	213	2.5	U-WLB1010-4
DMP1200UFR4	Single	Yes	12	8	2	1.26	100	160	200	0.35	1	510	5.8	X2-DFN1010-3
DMP1096UCB4	Single	Yes	12	6	2.6	1.6	102	116	-	0.4	1	251	3.7	U-WLB1010-4
DMP1555UFA	Single	Yes	12	8	0.2	0.36	800	1100	3000	0.4	1	60	0.84	X2-DFN0806-3
DMG3415UFY4	Single	Yes	16	8	2.5	0.49	39	52	65	0.3	1	282	10	X2-DFN2015-3
DMP2006UFG	Single	No	20	10	17.5	2.3	5.5	7.5	12	0.4	1	5404	64	POWERDI3333-8
DMP2008UFG	Single	No	20	8	14	2.4	8	9.8	13	0.4	1	6909	72	POWERDI3333-8
DMP2018LFK	Single	Yes	20	12	9.2	2.1	16	20	-	0.45	1.2	4748	53	U-DFN2523-6
DMP2021UFDF	Single	Yes	20	8	9	2.1	16	22	40	0.35	1	2950	34	U-DFN2020-6
DMP2022LSS	Single	No	20	12	10	2.5	16	22	-	0.6	1.1	2444	28.1	SO-8
ZXM66P02N8	Single	No	20	12	8	1.56	25	45	-	0.7	-	2100	43.3	SO-8

8V – 29V P-CHANNEL (CONTINUED)



Part Number	Configuration	ESD Diode (Y/N)	V _{DS} (V)	V _{GS} (±V)	I _{DS} (A)	P _D (W)	R _{DS(ON)} (mΩ max) at V _{GS} =			V _{GS} (th) (V)		C _{ISS} typ @ V _{GS} =½V _{DSS} (pF)	Q _C typ @ V _{GS} = 4.5V (nC)	Package
					@T _A =25°C	@T _A =25°C	4.5V	2.5V	1.8V	Min.	Max.			
DMP2023UFD	Single	No	20	8	7.6	2.1	27	32	50	0.4	1	2000	27	U-DFN2020-6 Type F
DMP2033UCB9	Single	Yes	20	6	5.8	1.8	33	45	65	0.4	1.1	382	5.4	U-WLB1515-9
DMP2035U	Single	Yes	20	8	4	0.81	35	45	62	0.4	1	1610	15.4	SOT23
DMP2035UVT	Single	Yes	20	12	6	2	35	45	62	0.4	1.5	1610	15.4	TSOT26
DMP2066UFDE	Single	No	20	12	7.5	2.1	36	56	75	0.4	1.1	1537	14.4	U-DFN2020-6 Type E
DMP2038USS	Single	No	20	8	6.5	2.5	38	56	-	0.4	1.1	1520	14.4	SO-8
DMP2066LDM	Single	No	20	12	4.6	1.25	40	70	-	0.6	1.2	880	10.1	SOT26
DMP2066LSD	Dual	No	20	12	5.8	2	40	70	-	0.6	1.2	880	10.1	SO-8
DMP2066LSN	Single	No	20	12	4.6	1.25	40	70	-	0.6	1.2	880	10.1	SC59
DMP2066LSS	Single	No	20	12	6.5	2.5	40	70	-	0.6	1.2	880	10.1	SO-8
DMG3415U	Single	Yes	20	8	4	0.9	42.5	53	71	0.3	1	294	9.1	SOT23
DMP2100U	Single	Yes	20	10	4.3	1.3	43	75	-	0.3	1.4	220	9.1	SOT23
DMP2066LVT	Single	No	20	8	4.5	1.8	45	65	-	0.4	1.5	1537	14.4	SOT26
DMP2047UCB4	Single	Yes	20	6	4.1	1.6	47	60	-	0.4	1.2	218	2.3	U-WLB1010-4
DMG2305UX	Single	No	20	8	4.2	1.4	52	100	200	0.5	0.9	820	10.2	SOT23
DMP2069UFY4	Single	Yes	20	8	2.5	0.53	54	69	90	0.3	1	214	9.1	X2-DFN2015-3
DMP2305U	Single	No	20	8	4.2	1.4	60	90	113	0.5	0.9	800	7.6	SOT23
DMP2305UVT	Single	No	20	8	4.23	1.64	60	90	113	0.5	0.9	800	7.6	TSOT26
DMP2033UVT	Single	No	20	8	4.2	1.7	65	100	200	0.5	0.9	900	10.4	TSOT26
DMP2070UCB6	Single	No	20	8	3.5	1.47	70	90	110	0.4	1	210	2.9	U-WLB1510-6
DMP2160UFDB	Dual	No	20	12	3.8	1.4	70	85	-	0.45	0.9	536	6.5	U-DFN2020-6 Type B
DMP2160UFDBQ	Dual	No	20	12	3.8	1.4	70	85	-	0.45	0.9	536	6.5	U-DFN2020-6 Type B
DMP2123L	Single	No	20	12	3	1.4	72	123	-	0.6	1.25	460	7.3	SOT23
DMG9933USD	Dual	No	20	12	4.6	1.2	75	110	-	0.45	1.1	595	6.5	SO-8
DMP2130L	Single	No	20	12	3	1.4	75	125	-	0.6	1.25	460	7.3	SOT23
DMP2160U	Single	No	20	12	3.3	1.4	75	96	140	0.4	0.9	627	6.5	SOT23
DMG2301U	Single	No	20	8	2.7	0.8	80	110	-	0.45	1	600	6.5	SOT23
DMP2130LDM	Single	No	20	12	3.4	1.25	80	130	-	0.6	1.25	460	7.3	SOT26
DMP2060UFDB	Single	Yes	20	12	3.2	1.4	90	137	-	0.35	1.4	881	11	U-DFN2020-6 Type B
ZXM64P02X	Single	No	20	12	3.5	1.1	90	130	-	0.7	-	950	5	MSOP-8
DMG3413L	Single	No	20	8	3	1.3	95	125	190	0.6	1.3	857	9	SOT23
DMS2095LFDB	MOSFET + Schottky	No	20	12	3.4	1.64	95	120	150	0.4	1.3	561	7	U-DFN2020-6 Type B
DMP2160UW	Single	No	20	12	1.5	0.35	100	120	160	0.4	0.9	627	6.5	SOT323
DMP2215L	Single	No	20	12	2.7	1.1	100	215	-	0.45	1.25	250	4.3	SOT23
DMP2225L	Single	No	20	12	2.6	1.1	110	225	-	0.45	1.25	250	4.3	SOT23
DMS2085LSD	MOSFET + Schottky	No	20	20	3.3	1.8	125	-	-	0.5	2.2	410	3.7	SO-8
DMP2104LP	Single	No	20	12	1.5	0.5	150	200	240	0.45	1	330	-	X1-DFN1411-3
DMP2104V	Single	No	20	12	1.9	0.85	150	200	240	0.45	1	330	-	SOT563
DMP2240UDM	Single	No	20	12	2	0.6	150	200	240	0.45	1	340	-	SOT26
DMP2240UW	Single	No	20	12	1.5	0.25	150	200	240	0.45	1	340	-	SOT323
DMP2240UWQ	Single	No	20	12	1.5	0.25	150	200	240	0.45	1	340	-	SOT323
DMP2200UFCL	Single	Yes	20	8	1.7	1.6	200	290	390	0.4	1.2	184	2.2	U-DFN1616-6
ZXM62P02E6	Single	No	20	12	2.3	1.1	200	375	-	0.7	-	350	4.6	SOT26
DMP2200UDW	Single	Yes	20	8	0.9	0.6	260	500	1000	0.4	1.2	184	2.1	SOT363
ZXMD63P02X	Dual	No	20	12	1.7	1.25	270	400	-	0.7	-	300	4.1	MSOP-8
DMP2012SN	Single	Yes	20	12	0.7	0.5	300	500	-	0.5	1.2	178	-	SC59
DMP21D0UFB	Single	Yes	20	8	1.17	0.99	495	690	960	0.45	1.2	76.5	1	X1-DFN1006-3
DMP21D0UFB4	Single	Yes	20	8	1.17	0.99	495	690	960	0.45	1.2	76.5	1	X2-DFN1006-3
DMP21D0UFD	Single	Yes	20	8	1.14	0.93	495	730	960	0.45	1.2	76.5	1	X1-DFN1212-3
DMP21D0UT	Single	Yes	20	8	0.65	0.33	495	690	960	0.45	1.2	76.5	1	SOT523
ZXM61P02F	Single	No	20	12	0.9	0.625	600	900	-	0.7	1.5	160	3.5	SOT23

8V – 29V P-CHANNEL (CONTINUED)



Part Number	Configuration	ESD Diode (Y/N)	V _{DS} (V)	V _{GS} (±V)	I _{DS} (A) @T _A =25°C	P _D (W) @T _A =25°C	R _{DS(ON)} (mΩ max) at V _{GS} =			V _{GS} (th) (V)		C _{ISS} typ @ V _{GS} =½V _{DSS} (pF)	Q _G typ @ V _{GS} = 4.5V (nC)	Package
							4.5V	2.5V	1.8V	Min.	Max.			
DMG1013T	Single	Yes	20	6	0.46	0.27	700	900	1300	0.5	1	62	0.58	SOT523
DMG1013UW	Single	Yes	20	6	0.82	0.31	750	1050	1500	0.5	1	62	0.62	SOT323
DMG1023UV	Dual	Yes	20	6	1.03	0.53	750	1050	1500	0.5	1	62	0.62	SOT563
DMP2004DMK	Dual	Yes	20	8	0.55	0.5	900	1400	2000	0.5	1	95	-	SOT26
DMP2004DWK	Dual	Yes	20	8	0.43	0.25	900	1400	2000	0.5	1	95	-	SOT363
DMP2004K	Single	Yes	20	8	0.6	0.55	900	1400	2000	0.5	1	95	-	SOT23
DMP2004VK	Dual	Yes	20	8	0.53	0.4	900	1400	2000	0.5	1	95	-	SOT563
DMP2004WK	Single	Yes	20	8	0.4	0.25	900	1400	2000	0.5	1	95	-	SOT323
DMP21D2UFA	Single	Yes	20	8	0.33	0.36	1000	1200	1600	0.3	1	55	0.8	X2-DFN0806-3
DMP21D5UFB4	Single	Yes	20	8	0.7	0.95	1000	1500	2000	0.5	1	46	0.5	X2-DFN1006-3
DMP21D5UFD	Single	Yes	20	8	0.6	0.8	1000	1500	2000	0.5	1	46	0.5	X1-DFN1212-3
DMP2004TK	Single	Yes	20	8	0.43	0.15	1100	1600	2400	0.5	1	95	-	SOT523
DMP22D6UT	Single	Yes	20	8	0.43	0.15	1100	1600	2600	0.5	1	95	-	SOT523
DMP22D4UFA	Single	Yes	20	8	0.33	0.4	1900	2400	3400	0.4	1	29	0.4	X2-DFN0806-3
DMP210DUFB4	Single	Yes	20	8	0.2	0.35	5000	7000	10000	0.5	1	14	-	X2-DFN1006-3
DMP210DUDJ	Dual	Yes	20	8	0.2	0.33	5500	7500	11500	0.45	1.15	14	-	SOT963
DMP2039UFDE4	Single	Yes	25	8	7.3	2.4	26	33	40	0.4	1	2600	28.2	X2-DFN2020-6
DMP2039UFDE	Single	Yes	25	8	6.7	2	27	34	40	0.4	1	2580	28.2	U-DFN2020-6 Type E
DMP2540UCB9	Single	Yes	25	6	5.2	1.8	40	50	60	0.4	1.1	342	4.8	U-WLB1515-9
DMG302PU	Single	Yes	25	8	0.17	0.45	10000	-	-	0.65	1.5	27.2	0.35	SOT23
DMP213DUFA	Single	Yes	25	8	0.166	0.36	10000	13000	-	0.65	1.5	27.2	0.35	X2-DFN0806-3

OPTIMIZED COMPLEMENTARY MOSFETS ENHANCE BUCK CONVERTER POWER DENSITY

Did you know? Aimed at increasing the power density of DC-DC converters, the DMC1028UFDB complementary MOSFET pair integrates an N-channel MOSFET and a P-channel MOSFET in a single DFN2020 package.

The design is customized for point-of-load (POL) converters that step down from 3.3V to 1V for core voltage supply to ASICs.

Target applications are Ethernet network controllers and processors used in such equipment as routers, network interface controllers (NICs), switches, digital subscriber line (DSL) adaptors, servers, and set-top boxes (STBs).

Buck converters implemented using a separate PWM controller and external MOSFETs enhance design flexibility and provide for distributed heat dissipation from the switching elements.

The performance parameters of the DMC1028UFDB MOSFETs have been optimized to maximize efficiency in 3.3V to 1V buck converters while driving loads up to 3A.

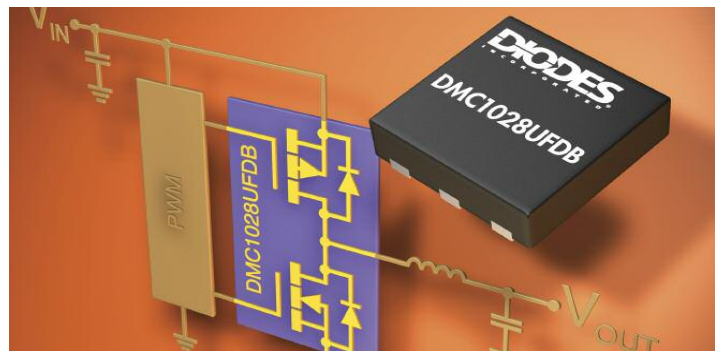

THE DIODES ADVANTAGE

- Complementary N+P**
 Integrating N-channel and P-channel into single DFN2020 saves space and overall doubles the power density by replacing two single DFN2020 parts.
- Optimized MOSFETs for increased efficiency**
 The N-channel has a low $R_{DS(ON)} = 19\text{m}\Omega$ at $V_{GS}=3.3\text{V}$ to minimize the conduction losses as it is mostly on for two-thirds of the switching cycle; and the P-channel has a low $Q_G = 5\text{nC}$ at $V_{GS}=3.3\text{V}$ to minimize the switching losses.
- P-channel for high-side**
 Implementing the control FET on the high-side in the buck converter with a P-channel simplifies the design and reduces the component count compared to using an N-channel solution that would require a charge pump.

8V – 29V COMPLEMENTARY



Part Number	Configuration	Type	ESD Diode (Y/N)	V _{DS} (V)	V _{CS} (±V)	I _{DS} (A)	P _D (W)	R _{DS(ON)} (mΩ max) at V _{CS} =			V _{GS(th)} (V)		C _{ISS} typ @ V _{CS} =½V _{DSS} (pF)	Q _C typ @ V _{GS} =10V (nC)	Package
						@T _A =25°C	@T _A =25°C	4.5V	2.5V	1.8V	Min.	Max.			
DMC1017UPD	Complementary	N	No	12	8	9.5	2.3	17	25	-	0.6	1.5	1787	18.6	POWERDI5060-8
		P	No	12	8	6.9		32	53	-	0.6	1.5	2100	23.7	
DMC25D1UVT	Complementary	N	Yes	25	8	0.5	1.3	4000	-	-	0.65	1.5	27.6	0.4	TSOT26
		P	Yes	12	8	3.9		55	70	100	0.35	1.5	9.7	24.5	
DMC1028UFDB	Complementary	N	Yes	12	8	6	1.36	25	32	40	0.4	1	787	10.5	U-DFN2020-6 Type B
		P	Yes	20	8	3.4		80	100	140	0.4	1	576	6.7	
DMC1029UFDB	Complementary	N	No	12	8	5.6	1.4	29	34	44	0.4	1	914	10.5	U-DFN2020-6 Type B
		P	No	12	8	3.8		61	81	115	0.4	1	915	10.7	
DMC1030UFDB	Complementary	N	Yes	12	8	5.1	1.36	34	40	50	0.4	1	1003	12.2	U-DFN2020-6 Type B
		P	Yes	20	8	3.9		59	81	115	0.4	1	1028	13	
DMC1229UFDB	Complementary	N	No	12	8	5.6	1.4	29	34	44	0.4	1	914	10.5	U-DFN2020-6 Type B
		P	No	12	8	3.8		61	81	115	0.4	1	915	10.7	
DMC2020USD	Complementary	N	Yes	20	10	7.8	1.8	20	28	-	0.5	1.5	1149	11.6	SO-8
		P	Yes	20	10	6.3		33	45	-	0.4	1	1610	15.4	
DMC2038LVT	Complementary	N	No	20	12	4.5	1.1	35	43	56	0.4	1	400	5.7	TSOT26
		P	No	20	12	3.1		74	110	168	0.4	1	530	7	
DMC2041UFDB	Complementary	N	Yes	20	12	4.7	1.4	40	65	-	0.35	1.4	713	8	U-DFN2020-6 Type B
		P	Yes	20	12	3.2		90	137	-	0.35	1.4	881	11	
ZXMD63C02X	Complementary	N	No	20	12	2.4	1.25	130	150	-	0.7	-	360	6	MSOP-8
		P	No	20	12	1.7		270	400	-	0.7	-	300	5.25	
DMC2700UDM	Complementary	N	Yes	20	6	1.34	1.12	400	500	700	0.5	1	65	0.74	SOT26
		P	Yes	20	6	1.14		700	900	1300	0.5	1	63	0.62	
DMG1016UDW	Complementary	N	Yes	20	6	1.07	0.33	450	600	750	0.5	1	65	0.74	SOT363
		P	Yes	20	6	0.85		750	1050	1500	0.5	1	63	0.62	
DMG1016V	Complementary	N	Yes	20	6	0.87	0.53	400	500	700	0.5	1	65	0.74	SOT563
		P	Yes	20	6	0.64		700	900	1300	0.5	1	63	0.62	
DMC2004DWK	Complementary	N	Yes	20	8	0.54	0.25	550	700	900	0.5	1	85	-	SOT363
		P	Yes	20	8	0.43		900	1400	2000	0.5	1	95	-	
DMC2004LPK	Complementary	N	Yes	20	8	0.75	0.5	550	700	900	0.5	1	85	-	X1-DFN1612-6
		P	Yes	20	8	0.6		900	1400	2000	0.5	1	95	-	
DMC2004VK	Complementary	N	Yes	20	8	0.67	0.4	550	700	900	0.5	1	85	-	SOT563
		P	Yes	20	8	0.53		900	1400	2000	0.5	1	95	-	
DMC2400UV	Complementary	N	Yes	20	8	1	1	500	700	900	0.5	0.9	37	0.5	SOT563
		P	Yes	20	8	0.7		1000	1500	2000	0.5	1	46	0.5	
DMC2990UDJ	Complementary	N	Yes	20	8	0.45	0.35	990	1200	1800	0.5	1	27.6	0.5	SOT963
		P	Yes	20	8	0.31		1900	2400	3400	0.4	1	28.7	0.4	

DUAL, COMMON-SOURCE / DRAIN

Part Number	Configuration	ESD Diode (Y/N)	V _{DS} (V)	V _{GS} (±V)	I _{DS} (A) @T _A =25°C	P _D (W) @T _A =25°C	R _{DS(ON)} (mΩ max) at V _{GS} =			V _{GS(th)} (V)		C _{ISS} typ @ V _{GS} = ½V _{DSS} (pF)	Q _G typ @ V _{GS} = 4.5V (nC)	Package
							4.5V	2.5V	1.8V	Min.	Max.			
DMN1033UCB4	N+N Common Drain	Yes	12	6	5.5	1.45	26	31	33	0.35	0.7	2500	37	U-WLB1818-4
DMN2011UFX	N+N Common Drain	Yes	20	12	12.2	2.1	9.5	13	-	0.3	1	2248	24	V-DFN2050-4
DMN2013UFX	N+N Common Drain	Yes	20	8	10	0.78	11.5	14	-	0.5	1.1	2607	32.4	W-DFN5020-6
DMN2014LHAB	N+N Common Drain	Yes	20	12	9	0.8	13	18	28	0.3	1.1	1550	16	U-DFN2030-6 Type B
DMN2016LHAB	N+N Common Drain	Yes	20	12	7.5	1.2	15.5	20	30	0.5	1.1	1550	16	U-DFN2030-6 Type B
DMN2016UTS	N+N Common Drain	Yes	20	8	8.6	0.88	14.5	16.5	-	0.4	1	1495	16.5	TSSOP-8
DMN2016LFC	N+N Common Drain	Yes	20	8	5.2	0.77	18	22	30	0.4	1.1	1472	16	U-DFN3030-8
DMN2019UTS	N+N Common Drain	Yes	20	12	5.4	0.78	21	24	31	0.35	0.95	143	8.8	TSSOP-8
DMN2028UFDH	N+N Common Drain	Yes	20	12	6.8	1.1	22	26	36	0.5	1	151	8.5	POWERDI3030-8
DMG6968UTS	N+N Common Drain	Yes	20	12	5.2	1	23	27	34	0.35	0.95	143	8.8	TSSOP-8
DMG8601UFC	N+N Common Drain	Yes	20	12	6.1	0.92	23	27	34	0.35	1.05	143	8.8	U-DFN3030-8
DMG6968UDM	N+N Common Drain	Yes	20	12	6.5	0.85	24	28	34	0.5	0.9	143	8.8	SOT26
DMG8822UTS	N+N Common Drain	No	20	8	4.9	0.87	25	29	37	0.5	0.9	841	9.6	TSSOP-8
DMN2040LTS	N+N Common Drain	No	20	12	6.7	0.89	26	36	-	0.5	1.2	570	5.2	TSSOP-8
DMG9926UDM	N+N Common Drain	No	20	8	4.2	0.98	28	32	40	0.5	0.9	856	8.3	SOT26
DMP2035UTS	P+P Common Drain	Yes	20	8	6.04	0.89	35	45	62	0.4	1	1610	15.4	TSSOP-8
DMP2100UCB9	P+P Common Source	Yes	20	6	4	1.6	100	130	175	0.4	0.9	232	3.3	U-WLB1515-9
DMG5802LFX	N+N Common Drain	Yes	24	12	6.5	0.98	15	20	-	0.6	1.5	1080	14.5	W-DFN5020-6
DMN2023UCB4	N+N Common Drain	Yes	24	12	6	1.45	26	40	-	0.5	1.3	2564	29	X1-WLB1818-4
DMN32D2LDF	N+N Common Source	Yes	30	10	0.4	0.28	1200	1500	2200	0.6	1.2	38	-	SOT353

CHIP-SCALE BI-DIRECTIONAL MOSFET SAVES SPACE

Did you know? The DMN2023UCB4 bi-directional MOSFET provides superior protection for charging 1- and 2-cell lithium batteries. Its low on-state resistance reduces power loss while its thin, chip-scale packaging allows designers to use the space saved to increase battery capacity. Target end-markets include smartphones, tablets, cameras, portable media players, and similar consumer products where size, weight and battery life are all key performance factors.

Designed to minimize on-state resistance for lower power loss, the DMN2023UCB4 delivers an R_{DS(ON)} of less than 26mΩ. In addition, its dual, N-channel common-drain configuration particularly suits the charging circuits required for 1- and 2-cell lithium batteries, which commonly use a low-side battery switch. For applications requiring a high-side connection, Diodes Incorporated also offers the DMP2100UCB9, which provides a dual P-channel common-source MOSFET design.

The above features, coupled with a chip-scale package footprint of just 1.8mm x 1.8mm and a thickness of <0.4mm, make this new generation, bi-directional MOSFET well-suited for battery management, load switch and battery protection applications where smaller form factors are important. Other features include a gate threshold voltage of less than 1V, which is important to fully enhance the channel under low voltage operation, and built-in gate protection against electrostatic discharge (ESD) voltages of >2kV.

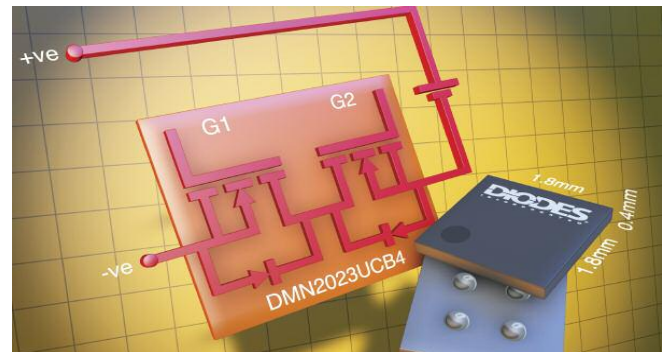

THE DIODES ADVANTAGE

Bi-directional, dual N-channel and P-channel MOSFETs configured for low-side and high-side operation as the battery protection switch, respectively.

- Bi-directional MOSFET**
 Combining dual-power MOSFETs back-to-back to block current flow in both directions when off and have low conduction losses when on.
- Small footprint**
 1.8mm x 1.8mm footprint and a thickness of < 0.4mm enables more space in the battery pack for additional cells to increase mAh capacity.
- Low on-resistance and threshold**
 DMN2023UCB4 has R_{SS(on)} <26mΩ minimizes conduction losses to increase battery life while V_{GS(th)} <1V ensures the FET is fully enhanced under low operating voltage.

30V N-CHANNEL



Part Number	Configuration	ESD Diode (Y/N)	V _{DS} (V)	V _{CS} (±V)	I _{DS} (A)	P _D (W)	R _{DS(ON)} (mΩ max) at V _{CS} =				C _{ISS} typ @ V _{CS} =½V _{DSS} (pF)	Q _C typ @ V _{CS} = 4.5V (nC)	Q _C typ @ V _{CS} = 10V (nC)	Package
					@T _A =25°C	@T _A =25°C	10V	4.5V	2.5V	1.8V				
DMN3008SFG	Single	No	30	20	17.6	0.9	4.6	5.5	-	-	3690	41	86	POWERDI3333-8
DMN3007LSS	Single	No	30	20	16	2.5	7	10	-	-	2714	31.2	64.2	SO-8
DMN3010LFG	Single	No	30	20	30	0.9	8.5	10.5	-	-	2075	16.1	37	POWERDI3333-8
DMN3010LSS	Single	No	30	20	16	2.5	9	13	-	-	2096	9	13	SO-8
DMG8880LK3	Single	No	30	20	16.5	1.68	9.3	14	-	-	1289	14.4	27.6	TO252 (DPAK)
DMN3010LK3	Single	No	30	20	43	1.6	9.5	11.5	-	-	2075	17	37	TO252 (DPAK)
DMG7702SFG	Single	No	30	20	12	0.89	10	15	-	-	1296	14.7	31.6	POWERDI3333-8
DMS3012SFG	Single	No	30	20	12	0.89	10	15	-	-	1296	14.7	31.6	POWERDI3333-8
DMG4406LSS	Single	No	30	20	10.3	1.5	11	15	-	-	1281	12.5	26.7	SO-8
DMG7430LFG	Single	No	30	20	10.5	0.9	11	15	-	-	1281	12.5	26.7	POWERDI3333-8
DMN3016LFDE	Single	No	30	20	10	0.73	12	16	-	-	1415	11.3	25.1	U-DFN2020-6 Type E
DMN3016LK3	Single	No	30	20	12.4	1.6	12	16	-	-	1415	11.3	25.1	TO252 (DPAK)
DMN3016LSS	Single	No	30	20	10.3	1.5	12	16	-	-	1415	11.3	25.1	SO-8
DMS3014SFG	Single	No	30	12	9.5	1	13	14	-	-	2296	45.7	19.3	POWERDI3333-8
DMS3016SFG	Single	No	30	12	10.2	0.98	13	16	-	-	1886	19.5	44.6	POWERDI3333-8
DMS3016SSSA	Single	No	30	12	9.8	1.54	13	16	-	-	1849	18.5	43	SO-8
DMN4468LSS	Single	No	30	20	10	1.52	14	20	-	-	867	-	18.85	SO-8
DMN4800LSS	Single	No	30	25	8.6	1.46	14	20	-	-	798	8.7	-	SO-8
DMN4800LSSL	Single	No	30	20	8	1.46	14	20	-	-	798	8.7	-	SO-8
DMN3015LSD	Dual	No	30	20	8.4	1.2	15	18	-	-	1415	11.3	25.1	SO-8
DMG4468LFG	Single	No	30	20	7.62	0.99	15	23.5	-	-	867	-	18.85	U-DFN3030-8
DMG4800LSD	Dual	No	30	25	8.4	1.17	16	22	-	-	798	8.6	-	SO-8
DMG4468LK3	Single	No	30	20	9.7	1.68	16	25	-	-	867	-	18.85	TO252 (DPAK)
ZXMN3B04N8	Single	No	30	12	8.9	3	-	25	40	-	2480	23.1	-	SO-8
DMG4800LK3	Single	No	30	25	10	1.71	17	24	-	-	798	8.7	-	TO252 (DPAK)
DMG4800LFG	Single	No	30	20	7.44	0.94	17	24	-	-	798	8.7	-	U-DFN3030-8
DMN3030LFG	Single	No	30	25	8.6	0.9	18	27	-	-	751	9	17.4	POWERDI3333-8
DMN3025LFG	Single	No	30	25	7.5	2	18	28	-	-	605	5.3	11.6	POWERDI3333-8
DMN3030LSS	Single	No	30	25	9	2.5	18	30	-	-	741	7.6	16.7	SO-8
DMN3029LFG	Single	No	30	25	8	1	18.6	26.5	-	-	580	5.3	11.3	POWERDI3333-8
DMG7410SFG	Single	No	30	25	8	1	20	27	-	-	580	5.3	11.3	POWERDI3333-8
DMG4822SSD	Dual	No	30	20	10	1.42	20	31	-	-	479	5	10.5	SO-8
DMN3025LSS	Single	No	30	20	7.2	1.4	20	31	-	-	641	6	13.2	SO-8
DMN3018SFG	Single	Yes	30	25	8.5	1	21	35	-	-	697	6	13.2	POWERDI3333-8
DMN3018SSS	Single	Yes	30	25	7.3	1.4	21	35	-	-	697	6	13.2	SO-8
DMG4496SSS	Single	No	30	25	10	1.42	21.5	29	-	-	493.5	4.7	10.2	SO-8
DMN3033LSD	Dual	No	30	20	6.9	2	22	27	-	-	725	6.4	13	SO-8
DMN3018SSD	Dual	No	30	25	6.7	1.5	22	30	-	-	697	6	13.2	SO-8
DMN3026LVT	Single	No	30	20	6.6	1.2	23	30	-	-	643	5.7	12.5	TSOT26
DMG4466SSS	Single	No	30	25	10	1.42	23	33	-	-	479	5	10.5	SO-8
DMG4466SSSL	Single	No	30	20	10	1.42	23	33	-	-	479	5	10.5	SO-8
DMG7408SFG	Single	No	30	20	7	1	23	33	-	-	479	5	10.5	POWERDI3333-8
DMN3024SFG	Single	No	30	20	7.5	0.9	23	33	-	-	479	5	10.5	POWERDI3333-8
DMN3024LSD	Single	No	30	20	7.2	2	24	36	-	-	608	6.3	12.9	SO-8
DMN3024LSS	Single	No	30	20	8.5	2.8	24	36	-	-	608	6.3	12.9	SO-8
DMN3024LK3	Single	No	30	20	14.4	8.9	24	39	-	-	608	6.3	12.9	TO252 (DPAK)
ZXMN3F31DN8	Dual	No	30	20	7.3	2.1	24	39	-	-	608	6.3	12.9	SO-8
DMN3404L	Single	No	30	20	4.2	0.72	28	42	-	-	498	5.3	11.3	SOT23
DMN3032LE	Single	No	30	20	5.6	1.8	29	35	-	-	498	4.1	11.3	SOT223
DMN3033LSN	Single	No	30	20	6	1.4	30	40	-	-	755	10.5 @5V	-	SC59
DMG6402LVT	Single	No	30	20	6	1.75	30	42	-	-	498	-	11.4	TSOT26

30V N-CHANNEL (CONTINUED)



Part Number	Configuration	ESD Diode (Y/N)	V _{DS} (V)	V _{GS} (±V)	I _{DS} (A)	P _D (W)	R _{DS(ON)} (mΩ max) at V _{GS} =				C _{ISS} typ @ V _{GS} =½V _{DSS} (pF)	Q _C typ @ V _{GS} = 4.5V (nC)	Q _C typ @ V _{GS} = 10V (nC)	Package
					@T _A =25°C	@T _A =25°C	10V	4.5V	2.5V	1.8V				
DMN3033LDM	Single	No	30	20	6.9	2	33	40	-	-	755	6.4	13	SOT26
DMN3051L	Single	No	30	20	4.5	0.7	38	64	-	-	424	-	9	SOT23
DMN3051LDM	Single	No	30	20	4	0.9	38	64	-	-	424	4.3	8.6	SOT26
DMN3070SSN	Single	Yes	30	20	4.2	0.78	40	50	80	-	697	6	13.2	SC59
DMN3053L	Single	No	30	12	4	0.76	45	50	55	-	676	7.3	17.2	SOT23
DMN3115UDM	Single	Yes	30	8	3.2	0.9	-	60	80	-	476	-	-	SOT26
DMN3067LW	Single	No	30	12	2.6	1.1	-	67	98	-	447	4.6	-	SOT323
ZXMN3F30FH	Single	No	30	20	4.6	1.4	47	65	-	-	318	-	7.7	SOT23
ZXMN3A03E6	Single	No	30	20	4.6	1.7	50	65	-	-	600	6.9 @ 5V	12.6	SOT26
DMG3402L	Single	No	30	12	4	1.4	52	65	85	-	464	5.5	11.7	SOT23
DMN3065LW	Single	No	30	12	4	0.77	52	65	85	-	465	5.5	11.7	SOT323
DMN3150L	Single	No	30	12	3.8	1.4	54	72	115	-	305	3.7	8.2	SOT23
DMN3112SSS	Single	No	30	20	6	2.5	57	112	-	-	268	-	-	SO-8
DMG3418L	Single	No	30	12	4	1.4	60	70	150	-	464	5.5	-	SOT23
ZXMN3B14F	Single	No	30	12	3.5	1.5	-	80	140	-	568	6.7	-	SOT23
DMN3200U	Single	Yes	30	8	2.2	0.65	-	90	110	200	290	-	-	SOT23
DMN3135LVT	Dual	No	30	20	3.5	0.84	60	100	-	-	305	4.1	9	TSOT26
ZXMN3A14F	Single	No	30	20	3.9	1.5	65	95	-	-	448	-	8.6	SOT23
DMN3110S	Single	No	30	20	3.3	0.74	73	110	-	-	306	4.1	8.6	SOT23
DMN3300U	Single	No	30	12	2	0.7	-	150	200	250	193	-	-	SOT23
ZXMN3B01F	Single	No	30	12	2	0.806	-	150	240	-	258	2.93	-	SOT23
ZXMN3A01E6	Single	No	30	20	3	1.7	120	180	-	-	190	2.3 @ 5V	3.9	SOT26
ZXMN3A01F	Single	No	30	20	2	0.625	120	180	-	-	190	2.3 @ 5V	3.9	SOT23
ZXMN3AMC	Dual	No	30	20	3.7	2.45	120	180	-	-	190	2.3	3.9	W-DFN3020-8 Type B
ZXMD63N03X	Dual	No	30	20	2.3	1.25	135	200	-	-	290	-	8	MSOP-8
DMN100	Single	Yes	30	20	1.1	0.5	150	170	-	-	150	-	5.5	SC59
DMN3190LDW	Dual	Yes	30	20	1	0.32	190	335	-	-	87	0.9	2	SOT363
ZXM61N03F	Single	No	30	20	1.4	0.625	220	300	-	-	150	-	4.1	SOT23

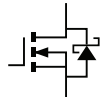

DIODES' SCHOTTKY INTEGRATED MOSFET

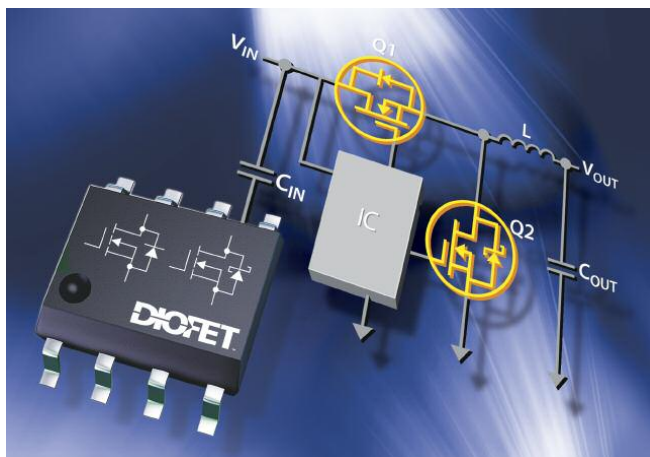

THE DIODES ADVANTAGE

- Diodes Incorporated has designed and patented a proprietary process that integrates a N-channel MOSFET and an anti-parallel schottky diode into a single die.
- Targeted at the low-side synchronous MOSFET position of synchronous point-of-load (PoL) converters, the lower V_{SD} and Q_{rr} of the DIOFET® family reduce conduction and switching losses improving the overall efficiency of the PoL converter lowering its operating temperature.
- **Low R_{DS(ON)}**
The low R_{DS(ON)} of the DIOFET minimize the conduction losses traditionally associated with high duty cycle synchronous MOSFETs.

DIOFET is a registered trademark of Diodes Incorporated.

30V N-CHANNEL (CONTINUED)



Part Number	Configuration	ESD Diode (Y/N)	V _{DS} (V)	V _{GS} (±V)	I _{DS} (A)		R _{DS(ON)} (mΩ max) at V _{GS} =				C _{ISS} typ @ V _{GS} =½V _{DSS} (pF)	Q _C typ @ V _{GS} = 4.5V (nC)	Q _C typ @ V _{GS} = 10V (nC)	Package
					@T _A =25°C	@T _A =25°C	at V _{GS} =							
							10V	4.5V	2.5V	1.8V				
DMN3730U	Single	Yes	30	8	0.94	0.71	-	460	560	730	64.3	1.6	-	SOT23
DMN3730UFB	Single	Yes	30	8	0.91	0.69	-	460	560	730	64.3	1.6	-	X1-DFN1006-3
DMN3730UFB4	Single	Yes	30	8	0.91	0.69	-	460	560	730	64.3	1.6	-	X2-DFN1006-3
DMN3900UFA	Single	Yes	30	8	0.65	0.49	-	760	930	1500	42.2	0.7	-	X2-DFN0806-3
DMN31D5UFZ	Single	Yes	30	12	0.22	0.393	-	1500	2000	3000	22.2	0.35	-	X2-DFN0606-3
DMN32D2LDF	Dual	Yes	30	10	0.4	0.28	-	-	1500	2200	39	-	-	SOT353
DMN32D2LFB4	Single	Yes	30	10	0.3	0.35	-	-	1500	2200	39	-	-	X2-DFN1006-3
DMN32D2LV	Dual	Yes	30	10	0.4	0.4	-	-	1500	2200	39	-	-	SOT563
DMN313DLT	Single	Yes	30	20	0.27	0.28	-	2000 @4V	3200	-	36.3	0.5	-	SOT523
DMN33D8LDW	Dual	Yes	30	20	0.25	0.35	2400	3000	7000	20000	48	0.55	1.23	SOT363
DMN33D8LV	Dual	Yes	30	20	0.35	0.43	2400	3000	7000	-	48	0.55	1.23	SOT563
DMN63D8LDW	Dual	Yes	30	20	0.26	0.3	2800	4200	13000	-	22	0.43	0.87	SOT363
DMN63D8LV	Dual	Yes	30	20	0.26	0.45	2800	4200	13000	-	22	0.43	0.87	SOT563
DMN33D8L	Single	Yes	30	20	0.25	0.35	3000	3800 @5V	-	-	50	-	1.2	SOT23
DMN33D8LT	Single	Yes	30	20	0.115	0.3	-	5000 @4V	7000	-	48	0.55	1.23	SOT523

30V P-CHANNEL



Part Number	Configuration	ESD Diode (Y/N)	V _{DS} (V)	V _{GS} (±V)	I _{DS} (A)		R _{DS(ON)} (mΩ max) at V _{GS} =				C _{ISS} typ @ V _{GS} =½V _{DSS} (pF)	Q _C typ @ V _{GS} = 4.5V (nC)	Q _C typ @ V _{GS} = 10V (nC)	Package
					@T _A =25°C	@T _A =25°C	at V _{GS} =							
							10V	4.5V	2.5V					
DMP3010LPS	Single	No	30	20	36	2.18	7.5	10	-	6234	59.2	126.2	POWERDI5060-8	
DMG4413LSS	Single	No	30	20	12	2.2	7.5	10.2	-	4965	46 @5V	-	SO-8	
DMP3010LK3	Single	No	30	20	17	1.7	8	10.2	-	6234	59.2	-	TO252 (DPAK)	
DMP3012LPS	Single	No	30	20	13.2	1.29	9	12	-	6807	66	139	POWERDI5060-8	
DMP3017SFG	Single	Yes	30	25	11.5	0.94	10	18	-	2246	20.5	41	POWERDI3333-8	
DMP3015LSS	Single	No	30	20	13	2.5	11	17	-	2748	30	60.4	SO-8	
DMG4407SSS	Single	Yes	30	25	9.9	1.45	13	14	-	2246	20.5	41	SO-8	
DMG7401SFG	Single	Yes	30	25	9.8	0.94	13	25	-	-	20.5	41	POWERDI3333-8	
DMP3017SFK	Single	Yes	30	25	10.4	1	14	25	-	2207	21.6	42.7	U-DFN2523-6	
DMP3020LSS	Single	No	30	25	12	2.5	14	25	-	1802	15.3	30.7	SO-8	
DMP3008SFG	Single	No	30	20	8.6	0.9	17	25	-	2230	23	47	POWERDI3333-8	
DMP3035LSS	Single	No	30	25	11	2	18	36	-	1655	15.3	30.7	SO-8	
DMG4435SSS	Single	No	30	25	7.3	2.5	20	29 @5V	-	1614	18.9 @5V	35.4	SO-8	
DMP3035SFG	Single	No	30	25	8.5	0.95	20	29 @5V	-	1633	17	35.5	POWERDI3333-8	
DMP3028LFDE	Single	No	30	20	6.8	0.66	25	38	-	-	10.9	22	U-DFN2020-6	
DMP3028LSD	Single	No	30	20	6	1.3	25	38	-	1241	10.9	22	SO-8	
DMP3037LSS	Single	No	30	20	5.8	1.2	32	50	-	931	9.7	19.3	SO-8	
DMP3065LVT	Single	Yes	30	20	4.9	1.2	42	65	-	587	6.3	12.3	TSOT26	
DMP3056LDM	Single	No	30	20	4.3	1.25	45	65	-	948	10.1	21.1	SOT26	
DMP3056LSD	Dual	No	30	20	6.9	2.5	45	65	-	722	6.8	13.7	SO-8	
DMP3056LSS	Single	No	30	20	7.1	2.5	45	65	-	722	6.8	13.7	SO-8	
ZXMP3A16G	Single	No	30	20	7.5	3.9	45	70	-	1022	17.2 @5V	29.6	SOT223	
DMP3050LSS	Single	No	30	25	4.8	1.7	45	80	-	620	5.1	10.5	SO-8	
DMG3401LSN	Single	No	30	12	3	0.8	50	60	85	1326	11.6	25.1	SC59	
DMG3407SSN	Single	No	30	20	4	1.1	50	72	-	582	6.5	13.3	SC59	

30V P-CHANNEL (CONTINUED)



Part Number	Configuration	ESD Diode (Y/N)	V _{DS} (V)	V _{GS} (±V)	I _{DS} (A)	P _D (W)	R _{DS(ON)} (mΩ max) at V _{GS} =			C _{ISS} typ @ V _{GS} =½V _{DSS}	Q _C typ @ V _{GS} = 4.5V	Q _C typ @ V _{GS} = 10V	Package
					@T _A =25°C	@T _A =25°C	10V	4.5V	2.5V	(pF)	(nC)	(nC)	
DMP3050LVT	Single	No	30	25	4.5	1.8	50	90	-	620	5.1	10.5	TSOT26
DMP3099L	Single	No	30	20	3.8	1.08	65	99	-	563	5.2	11	SOT23
DMP3098LDM	Single	No	30	20	4	1.25	65	115	-	336	4	7.8	SOT26
DMP3098LSD	Dual	No	30	20	4.4	1.8	65	115	-	336	4	7.8	SO-8
DMP3098LSS	Single	No	30	20	5.3	2.5	65	115	-	336	4	7.8	SO-8
DMP3085LSD	Dual	No	30	20	3.9	1.1	70	95	-	563	5.2	11	SO-8
DMP3085LSS	Single	No	30	20	3.8	1.3	70	95	-	563	5.2	11	SO-8
ZXMP3A17E6	Single	No	30	20	4	1.7	70	110	-	630	8.28 @ 5V	15.8	SOT26
DMP3098L	Single	No	30	20	3.8	1.08	70	120	-	336	4	7.8	SOT23
DMP3105LVT	Single	No	30	12	3.9	1.15	75	98	150	839	9	19.8	TSOT26
ZXM64P03X	Single	No	30	20	3.8	1.1	75	100	-	825	-	46	MSOP-8
DMP3130L	Single	No	30	12	3.5	0.7	77	95	150	432	5.9	12	SOT23
ZXMP3F30FH	Single	No	30	20	3.4	1.4	80	140	-	370	-	7	SOT23
DMC2307L	Single	No	30	20	2.5	0.76	90	134	-	371.3	4	8.2	SOT23
DMP3160L	Single	No	30	20	2.7	1.08	122	190	-	384.4	4	8.2	SOT23
ZXM62P03E6	Single	No	30	12	1.5	0.625	150	230	-	330	-	10.2	SOT26
ZXMD63P03X	Dual	No	30	20	2	1.25	185	270	-	270	-	7	MSOP-8
ZXMP3A13F	Single	No	30	20	1.6	0.806	210	330	-	206	3.8 @ 5V	6.4	SOT23
DMP3030SN	Single	Yes	30	20	0.7	0.5	250	450	-	160	-	-	SC59
ZXM61P03F	Single	No	30	20	1.1	0.625	350	550	-	140	-	4.8	SOT23
DMP31D0U	Single	Yes	30	8	0.67	0.71	-	1000	1500	76	0.9	1.5 @ 8V	SOT23
DMP31D0UFB4	Single	Yes	30	8	0.76	0.92	-	1000	1500	76	0.9	1.5 @ 8V	X2-DFN1006-3
DMP32D4S	Single	Yes	30	20	0.3	0.37	2400	4000	16000	51.2	0.6	1.2	SOT23
DMP32D4SFB	Single	Yes	30	20	0.4	0.5	2400	4000	16000	51	0.6	1.3	X1-DFN1006-3
DMP32D4SW	Single	Yes	30	20	0.25	0.3	2400	4000	16000	51.2	0.6	1.2	SOT323
DMP32D9UFZ	Single	Yes	30	10	0.2	0.39	-	5000	6000	22.5	0.35	-	X2-DFN0606-3

NEW GENERATION 30V P-CHANNEL ENHANCEMENT MODE MOSFET



THE DIODES ADVANTAGE

- The PowerDI5060 package has a typical R_{thj-c} of 2.1°C/W which is 10 times lower than the familiar SO-8 package. This superior thermal performance improves power dissipation, reducing MOSFET junction temperature, enabling cooler, more reliable running.
- The low typical R_{DS(ON)} of the DMP3010LPS ensures that on state losses are kept to a minimum during load switching and battery charging.
- The DMP3010LPS is qualified to AECQ-101 standard and is RoHS compliant.

30V COMPLEMENTARY



Part Number	Configuration	Type	ESD Diode (Y/N)	V _{DS} (V)	V _{GS} (±V)	I _{DS} (A) @T _A =25°C	P _D (W) @T _A =25°C	R _{DS(ON)} (mΩ max) at V _{GS} =		C _{ISS} typ @ V _{GS} =½V _{DSS} (pF)	Q _C typ @ V _{GS} = 4.5V (nC)	Q _C typ @ V _{GS} = 10V (nC)	Package
								10V	4.5V				
DMC3016LSD	Complementary	N	No	30	20	8.2	1.2	16	20	1415	11.3	25.1	SO-8
		P		30	20	6.2		28	38	1241	10.9	22	
DMC3018LSD	Complementary	N	No	30	20	9.1	2.5	20	32	631	5.9	12.4	SO-8
		P		30	20	6		45	65	722	7	13.7	
DMC3025LSD	Complementary	N	No	30	20	6.5	1.2	20	32	501	4.6	9.8	SO-8
		P		30	20	4.2		45	85	590	5.1	10.5	
DMC3021LSD	Complementary	N	No	30	20	8.5	2.5	21	32	767	7.8	16.1	SO-8
		P		30	20	7		39	53	1002	10	21.1	
DMC3021LK4	Complementary	N	No	30	20	9.4	2.75	21	32	751	9	17.4	TO252-4
		P		30	20	6.8		39	53	1039	10.1	21.1	
ZXMC3F31DN8	Complementary	N	No	30	20	7.3	2.1	24	39	608	-	12.9	SO-8
		P		30	20	5.3		45	80	670	-	12.7	
ZXMC3A18DN8	Complementary	N	No	30	20	7.6	2.1	25	30	1800	19.4 @ 5V	36	SO-8
		P		30	20	6.3		35	50	1603	25 @ 5V	45	
DMC3028LSDX	Complementary	N	No	30	20	5.5	1.2	27	35	641	6	13.2	SO-8
		P		30	20	5.8		25	41	1241	10.9	22	
DMC3028LSD	Complementary	N	No	30	20	7.1	2.1	28	45	472	5.2	10.5	SO-8
		P		30	20	7.4		25	41	1678	16.4	31.6	
DMC3032LSD	Complementary	N	No	30	20	8.1	2.5	32	46	404.5	-	9.2	SO-8
		P		30	20	7		39	53	1002	10.1	21.1	
ZXMC3A16DN8	Complementary	N	No	30	20	6.4	2.1	35	50	796	9.2	17.5	SO-8
		P		30	20	5.4		48	70	970	12.9	24.9	
ZXMC3A17DN8	Complementary	N	No	30	20	5.4	2.1	50	65	600	6.9 @ 5V	12.2	SO-8
		P		30	20	4.4		70	110	630	8.3 @ 5V	15.8	
DMG6601LVT	Complementary	N	No	30	12	3.8	0.85	55	65	422	5.4	12.3	TSOT26
		P		30	12	2.5		110	142	541	6.5	13.8	
DMG6602SVT	Complementary	N	No	30	20	3.4	0.84	60	100	290	4	9	TSOT26
		P		30	20	2.8		95	140	350	4	7	
ZXMC3AMC	Complementary	N	No	30	20	3.7	2.45	120	180	190	2.3	3.9	W-DFN3020-8 Type B
		P		30	20	2.7		210	330	206	3.8	6.4	
ZXMD63C03X	Complementary	N	No	30	20	2.3	1.25	135	200	290	-	8	MSOP-8
		P		30	20	2		185	270	270	-	7	
DMC31D5UDJ	Complementary	N	Yes	30	12	0.22	0.35	-	1500	22.6	0.38	-	SOT963
		P		30	12	0.2		-	5000	21.8	0.35	-	

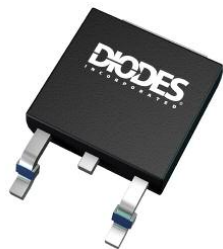

TO252 (DPAK)

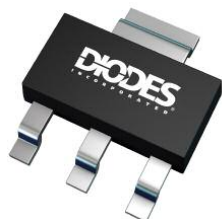

SOT223



SOT23

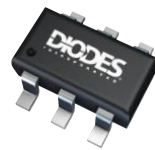

SOT26



SO-8



DFN 1006

31V – 50V N-CHANNEL



Part Number	Configuration	ESD Diode (Y/N)	V _{DS} (V)	V _{GS} (±V)	I _{DS} (A)	P _D (W)	R _{DS(ON)} (mΩ max) at V _{GS} =			C _{ISS} typ @ V _{GS} =½V _{DSS} (pF)	Q _C typ @ V _{GS} = 4.5V (nC)	Q _C typ @ V _{GS} = 10V (nC)	Package
					@T _A =25°C	@T _A =25°C	4.5V	2.5V	1.8V				
DMN4008LFG	Single	No	40	20	19.2	2.3	7.5	10	20 @ 3.3V	3537	34	74	POWERDI3333-8
DMN4010LK3	Single	No	40	20	39	1.6	11.5	14.5	-	1810	-	37	TO252 (DPAK)
DMN4020LFDE	Single	No	40	20	8	0.66	20	28	-	1060	-	19.1	U-DFN2020-6 Type E
DMN4010LFG	Single	No	40	20	11.5	2.45	12	15	-	1810	17	37	POWERDI3333-8
DMN4030LK3	Single	No	40	20	13.7	8.9	30	50	-	604	6.5	12.9	TO252 (DPAK)
DMN4040SK3	Single	No	40	20	13.8	8.9	30	54	-	945	8.4	18.6	TO252 (DPAK)
DMN4026SSD	Dual	No	40	20	9	1.8	24	32	-	1060	8.8	19.1	SO-8
DMN4034SSS	Single	No	40	20	7.2	2.8	34	59	-	453	4.9	10	SO-8
DMN4027SSD	Dual	No	40	20	7.1	2.1	27	47	-	604	6.3	12.9	SO-8
ZXMN4A06G	Single	No	40	20	7	3.9	50	75	-	770 @ 40V	-	18.2	SOT223
DMN4031SSD	Dual	No	40	20	7	2.6	31	50	-	945	8.4	18.6	SO-8
DMN4036LK3	Single	No	40	20	12.2	8.5	36	61	-	453	4.9	9.2	TO252 (DPAK)
DMN4034SSD	Dual	No	40	20	6.3	2.1	34	59	-	453	4.9	10	SO-8
DMT5015LDFD	Single	No	50	20	9.1	1.97	15	23	-	902	6	14	U-DFN2020-6 Type F
DMN53D0U	Single	Yes	50	12	0.3	0.52	-	2000 @ 5V	2500	37	0.6	-	SOT23
DMN5010VAK	Single	Yes	50	20	0.28	0.25	-	2000 @ 5V	2500	50 @ max	-	-	SOT563
DMN53D0LW	Single	No	50	20	0.36	0.32	2000	3000 @ 5V	-	45.8	0.6	1.2	SOT323
DMN55D0UT	Single	Yes	50	12	0.16	0.2	-	4000 @ 4V	5000	25 @ 10V	-	-	SOT523
DMN5L06DMK	Single	Yes	50	20	0.305	0.4	-	2000 @ 5V	2500	50 @ max	-	-	SOT26
DMN53D0L	Single	Yes	50	20	0.5	0.37	1600	2500	4500	46	0.6	-	SOT23
DMN53D0LDW	Single	Yes	50	20	0.36	0.31	1600	2500	4500	46	0.6	-	SOT363
DMN53D0LT	Single	Yes	50	20	0.35	0.3	1600	2500	4500	46	0.6	-	SOT523
DMN53D0LV	Single	Yes	50	20	0.35	0.43	1600	2500	4500	46	0.6	-	SOT563
BSN20	Single	No	50	20	0.5	0.6	1800	2000	-	21.8 @ 10V	-	800	SOT23
DMN5L06K	Single	Yes	50	20	0.3	0.35	-	2000 @ 5V	2500	50 @ max	-	-	SOT23
DMN5L06TK	Single	Yes	50	20	0.28	0.15	-	2000 @ 5V	2500	50 @ max	-	-	SOT523
DMN5L06VAK	Single	Yes	50	20	0.28	0.25	-	2000 @ 5V	2500	50 @ max	-	-	SOT563
DMN5L06VK	Single	Yes	50	20	0.28	0.25	-	2000 @ 5V	2500	50 @ max	-	-	SOT563
DMN5L06WK	Single	Yes	50	20	0.3	0.25	-	2000 @ 5V	2500	50 @ max	-	-	SOT323
DMN5L06DWK	Dual	Yes	50	20	0.305	0.25	-	2000 @ 5V	2500	50 @ max	-	-	SOT363
BSS138	Single	No	50	20	0.2	0.3	3500	-	-	50 max @ 10V	-	-	SOT23
BSS138DW	Dual	No	50	20	0.2	0.2	3500	-	-	50 max @ 10V	-	-	SOT363
BSS138W	Single	No	50	20	0.2	0.2	3500	-	-	50 max @ 10V	-	-	SOT323
DMB54DOUV	Single	Yes	50	12	0.16	0.25	-	4000 @ 4V	5000	25 @ 10V	-	-	SOT563

AUTOMOTIVE 'Q' MOSFETS FOR REVERSE BATTERY PROTECTION

Application Requirements

Protect against reverse polarity connection of the battery during vehicle maintenance. During the reconnection of a vehicle's battery it is possible to reverse the battery polarities causing damage to the vehicle's electronics.

- Simple, low cost, and minimal component count
- Minimal power losses
- Pulse ruggedness to ISO7637
- AEC-Q101 and PPAP required
- EMI Emissions

Key Products: 40V P-channel MOSFETs

- DMP4015SPSQ in PowerDI5060
- DMP4015SK3Q in TO252 (DPAK)
- DMP4015SSSQ in SO-8

REVERSE BATTERY PROTECTION CIRCUIT

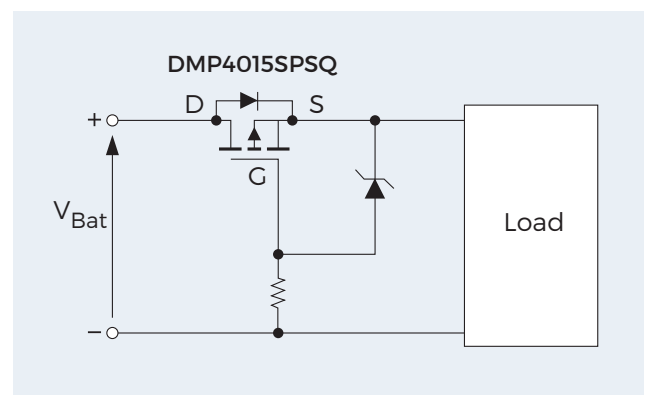

31V – 50V P-CHANNEL

Part Number	Configuration	ESD Diode (Y/N)	V _{DS} (V)	V _{GS} (±V)	I _{DS} (A)	P _D (W)	R _{DS(ON)} (mΩ max) at V _{GS} =			C _{ISS} typ @ V _{GS} =½V _{DSS} (pF)	Q _C typ @ V _{GS} = 4.5V (nC)	Q _C typ @ V _{GS} = 10V (nC)	Package
					@T _A =25°C	@T _A =25°C	10V	4.5V	2.5V				
DMP4015SK3	P	No	40	25	14	3.5	11	15	-	4234	47.5 @ -5V	-	TO252 (DPAK)
DMP4015SK3Q	P	No	40	25	14	3.5	11	15	-	4234	47.5 @ -5V	-	TO252 (DPAK)
DMP4015SPS	P	No	40	25	17	2.1	11	15	-	4234	47.5 @ -5V	47.5	POWERDI5060-8
DMP4015SPSQ	P	No	40	25	17	2.1	11	15	-	4234	47.5 @ -5V	-	POWERDI5060-8
DMP4015SSS	P	No	40	25	10.1	1.82	11	15	-	4234	47.5 @ -5V	-	SO-8
DMP4015SSSQ	P	No	40	25	10.1	1.82	11	15	-	4234	47.5 @ -5V	-	SO-8
DMP4025LK3	P	No	40	20	8.6	2.78	25	45	-	1643	14	33.7	TO252 (DPAK)
DMP4025LSD	P+P	No	40	20	7.6	2.14	25	45	-	1640	14	33.7	SO-8
DMP4025LSS	P	No	40	20	8	2.4	25	45	-	1640	14	33.7	SO-8
DMP4025SFC	P	No	40	20	7.2	1.95	25	40	-	1643	14	33.7	POWERDI3333-8
DMP4047LFDE	Single	No	40	20	6	2.1	33	50	-	1382	11.2	23.2	U-DFN2020-6
DMP4047SSD	Dual	No	40	20	6.5	1.8	45	55	-	1154	10.6	21.5	SO-8
DMP4050SSD	Dual	No	40	20	5.2	2.1	50	79	-	674	6.9	13.9	SO-8
DMP4050SSS	Single	No	40	20	6	2.8	50	79	-	674	6.9	13.9	SO-8
DMP4051LK3	Single	No	40	20	10.5	8.9	51	85	-	674	7	14	TO252 (DPAK)
ZXMP4A16G	Single	No	40	20	6.4	3.9	60	100	-	1007	13.6 @ 5V	26.1	SOT223
ZXMP4A16K	Single	No	40	20	9.9	9.5	60	100	-	965	16.5 @ 5V	29.6	TO252 (DPAK)
ZXMP4A57E6	Single	No	40	20	3.7	1.7	80	150	-	833	7	15.8	SOT26
BS250P	Single	No	45	20	0.23	0.7	14000	-	-	60 @ -10V	-	-	E-Line
BS250F	Single	No	45	20	0.09	0.33	14000	-	-	25 @ -10V	-	-	SOT23
BSS84DW	Dual	No	50	20	0.13	0.3	-	10000 @ 5V	-	45 max	-	-	SOT363
ZVP4105A	Single	No	50	20	0.175	0.625	-	10000 @ 5V	-	40 max	-	-	E-Line
BSS84	Single	No	50	20	0.13	0.3	-	10000 @ 5V	-	45 max	-	-	SOT23
BSS84V	Dual	No	50	20	0.13	0.15	-	110000 @ 5V	-	45 max	-	-	SOT563
BSS84W	Single	No	50	20	0.13	0.2	-	10000 @ 5V	-	45 max	-	-	SOT323
DMP56D0UFB	Single	Yes	50	8	0.2	0.425	-	6000 @ -4V	8000	50.54	0.58	-	X1-DFNI006-3
DMP56D0UV	Dual	Yes	50	8	0.16	0.4	-	6000 @ -4V	8000	50.54	0.58	-	SOT563
DMP58D0LFB	Single	Yes	50	20	0.31	1.22	-	8000 @ -5V	18000	27	-	-	X1-DFNI006-3
DMP58D0SV	Dual	Yes	50	20	0.16	0.4	-	8000 @ -5V	-	27	-	-	SOT563

MOSFETS FOR 3-PHASE BLDC MOTOR

MOSFET Application Requirements

- Peak current**
 During startup the coils are energized by a high peak current, up to five times greater than the continuous current rating.
- High torque current**
 Under high motor torque the coil current increases and the conduction losses (R_{DS(ON)}) in the MOSFET are to be minimized to ensure the junction temperature does not exceed the maximum rating.
- Switching losses**
 In each commutation, the MOSFET is switching in the coil current as the drain voltage collapses. With a high torque current in the coil then the MOSFET switching time needs to be minimized to reduce the switching power losses.
- dV/dt false-triggering**
 Commutating the coils induces rapid dV/dt changes on the MOSFET drain which could cause false turn on by coupling charge onto the gate. This can be avoided with the appropriate low (C_{GD} x R_C) and increasing V_{GS(TH)}.
- Key products**
 DMT series: shielded-gate MOSFETs with reduced conduction and switching losses.

3-PHASE BLDC CIRCUIT

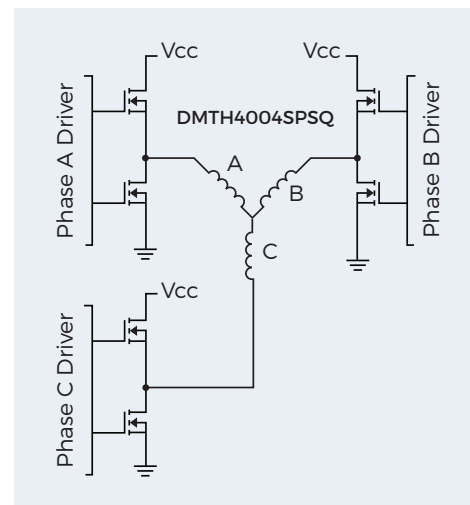

31V – 100V COMPLEMENTARY



Part Number	Configuration	Type	ESD Diode (Y/N)	V _{DS} (V)	V _{GS} (±V)	I _{DS} (A)	P _D (W)	R _{DS(ON)} (mΩ max) at V _{GS} =		C _{ISS} typ @ V _{GS} =½V _{DSS} (pF)	Q _C typ @ V _{GS} = 4.5V (nC)	Q _C typ @ V _{GS} = 10V (nC)	Package	
						@T _A =25°C		@T _A =25°C	10V					4.5V
DMC4047LSD	Complementary	N	No	40	20	7	1.8	24	32	1060	8.8	19.1	SO-8	
		P		40	20	5.1		45	55	1154	10.6	21.5		
DMC4029SSD	Complementary	N	No	40	20	9 @ t<10S	1.8	24	32	1060	8.8	19.1	SO-8	
		P		40	20	6.5 @ t<10S		45	55	1154	10.6	21.5		
DMC4040SSD	Complementary	N	No	40	20	7.5	2.14	25	40	1790	16	37.6	SO-8	
		P		40	20	7.3		25	45	1643	14	33.7		
DMC4028SSD	Complementary	N	No	40	20	7.2	2.16	28	49	604	6.5	12.9	SO-8	
		P		40	20	5.2		50	79	674	7	14		
DMC4050SSD	Complementary	N	No	40	20	5.5	2.14	45	60	1790	-	37.56	SO-8	
		P		40	20	5.8		45	60	1643	-	33.66		
ZXMC4A16DN8	Complementary	N	No	40	20	5.2	2.1	50	75	770 @ 40V	-	17	SO-8	
		P		40	20	4.7		60	100	1000	15 @ 5V	26		
BSS8402DW	Complementary	N	No	60	20	0.115	0.2		7500 @ 5V	22 @ 25V	-	-	SOT363	
		P		50	20	0.13			10000 @ 5V	45 max @ -25V	-	-		
DMC6040SSD	Complementary	N	No	60	20	6.5	-	40	55	1130	9.4	20.8	SO-8	
		P		60	20	3.9		110	130	1030	9.5	19.4		
ZXMC4559DN8	Complementary	N	No	60	20	4.7	2.2	55	75	1063 @ 30V	11 @ 5V	20.4	SO-8	
		P		60	20	3.9		85	125	1021 @ -30V	12.1 @ -5V	24.2		
DMC6070LFDH	Complementary	N	No	60	20	3.1	1.4	85	120	731 @ 20V	5.2	11.5	POWERDI3030-8	
		P		60	20	2.4		150	250	612 @ -20V	4.3	8.9		
DMG1029SV	Complementary	N	No	60	20	0.5	1	1700	3000	30 @ 25V	0.3	-	SOT563	
		P		60	20	0.36		4000	6000	25 @ -25V	0.28	-		
ZXMC10A816N8	Complementary	N	No	100	20	2.1	2.1	230	300	497	-	9.2	SO-8	
		P		100	20	2.2		235	320	717	-	16.5		

DMC4040SSD 40V V_{DS} COMPLEMENTARY DUAL MOSFET

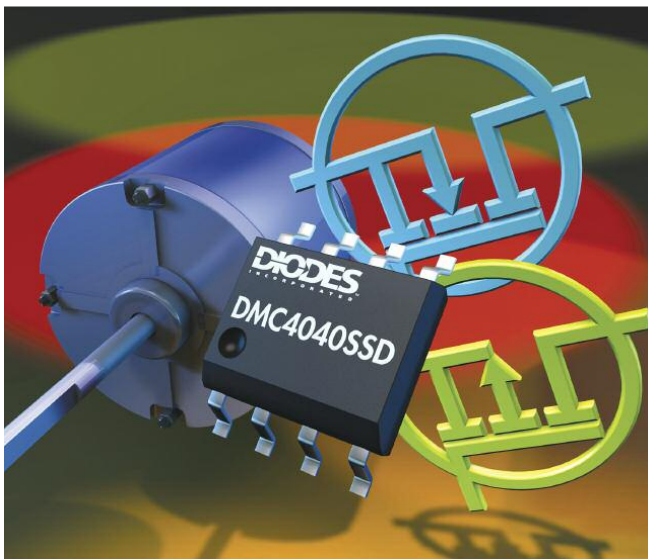

More information available in Application Note AN76.

THE DIODES ADVANTAGE

- Strong customer relationships and a deep understanding of their end applications are the primary drivers of the Diodes product development strategy.
- For example, Diodes Incorporated has recently worked with one of its major customers to develop a 40V complementary pair to meet the stringent requirements of brushless DC motor (BLDC) circuits.
- The result of this collaboration is the DMC4040SSD. A 40V V_{DS} complementary dual that features matched R_{DS(ON)}, to ensure motor load losses are balanced and minimized, and is able to handle continuous currents of 6A and peak start up currents of up to 5 times continuous.
- The DMC4040SSD is suited to use in 24V DC motor system controlling cooling and extractor fans, pumps, compressors and printer heads.
- The DMC4040SSD features matched R_{DS(ON)} of 25mΩ ensuring motor load losses are balanced and minimized.

51V – 99V N-CHANNEL



Part Number	Configuration	ESD Diode (Y/N)	V _{DS} (V)	V _{GS} (±V)	I _{DS} (A)	P _D (W)	R _{DS(ON)} (mΩ max) at V _{GS} =			C _{ISS} typ @ V _{GS} =½V _{DSS} (pF)	Q _C typ @ V _{GS} = 4.5V (nC)	Q _C typ @ V _{GS} = 10V (nC)	Package
					@T _A =25°C	@T _A =25°C	10V	4.5V	2.5V				
DMT6008LFG	Single	Yes	60	12	13	2.2	7.5	11.5	-	2713	22.4	50.4	POWERDI3333-8
DMT6010LFG	Single	No	60	20	13	2.2	7.5	11.5	-	2090	19.3	41.3	POWERDI3333-8
DMN6013LFG	Single	No	60	20	10.3	2.1	13	18	-	2577	26.6	55.4	POWERDI3333-8
DMT6016LDFD	Single	No	60	20	8.9	1.9	16	27	-	864	8.4	17	U-DFN2020-6
DMT6016LPS	Single	No	60	20	10.6	2.7	16	24	-	864	8.4	17	POWERDI5060-8
DMT6016LSS	Single	No	60	20	9.2	2.1	18	28	-	864	8.4	17	SO-8
DMN6040SFDE	Single	No	60	20	6.5	2.03	38	47	-	1287 @ 50V	10.4	22.4	U-DFN2020-6 Type E
DMN6040SK3	Single	No	60	20	20 @ Tc	42 @ Tc	40	50	-	1287 @ 25V	10.4	22.4	TO252 (DPAK)
DMN6040SSS	Single	No	60	20	5.5	2	40	55	-	1287 @ 25V	10.4	22.4	SO-8
DMN6040SSD	Dual	No	60	20	5	1.7	40	55	-	1287 @ 25V	10.4	22.4	SO-8
ZXMN6A09K	Single	No	60	20	11.8	10.1	40	60	-	1426	15	29	TO252 (DPAK)
ZXMN6A09DN8	Dual	No	60	20	5.6	2.1	40	60	-	1407 @ 40V	12.4 @ 5V	24.2	SO-8
ZXMN6A09C	Single	No	60	20	7.5	3.9	40	60	-	1407 @ 40V	12.4 @ 5V	24.2	SOT223
DMN6040SVT	Single	No	60	20	6.3	1.8	44	60	-	1287 @ 25V	10.4	22.4	TSOT26
ZXMN6A25K	Single	No	60	20	10.7	9.85	50	70	-	1063	11	20.4	TO252 (DPAK)
ZXMN6A25C	Single	No	60	20	6.7	3.9	50	70	-	1063	11 @ 5V	20.4	SOT223
ZXMN6A25N8	Single	No	60	20	5.7	2.8	50	70	-	1063	11 @ 5V	20.4	SO-8
ZXMN6A25DN8	Dual	No	60	20	5	2.1	50	70	-	1063	11 @ 5V	20.4	SO-8
DMN6066SSS	Single	No	60	20	5	2.8	66	97	-	502	5.4	10.3	SO-8
DMN6066SSD	Dual	No	60	20	4.4	2.1	66	97	-	502	5.4	10.3	SO-8
DMN6068LK3	Single	No	60	20	8.5	8.5	68	100	-	502	5.55	10.3	TO252 (DPAK)
DMN6068SE	Single	No	60	20	5.6	3.7	68	100	-	502	5.55	10.3	SOT223
DMN6069SE	Single	No	60	20	4.3	2.2	69	100	-	825	7.2	16	SOT223
DMN6070SSD	Dual	No	60	20	3.3	1.5	80	100	-	588	5.6	12.3	SO-8
ZXMN6A08K	Single	No	60	20	7.9	8.94	80	150	-	459 @ 40V	3.8	5.8	TO252 (DPAK)
ZXMN6A08E6	Single	No	60	20	3.5	1.7	80	150	-	459 @ 40V	3.7	5.8	SOT26
ZXMN6A08C	Single	No	60	20	5.3	3.9	80	150	-	459 @ 40V	4 @ 5V	5.8	SOT223
DMN6070SFCL	Single	No	60	20	3	1.8	85	120 @ 5V	-	606 @ 20V	5.6	12.3	X1-DFN1616-6 Type E
DMN6075S	Single	No	60	20	2.5	1.15	85	120	-	606 @ 20V	5.6	12.3	SOT23
ZXMN6A11DN8	Dual	No	60	20	3.2	2.1	120	180	-	330 @ 40V	3 @ 5V	5.7	SO-8
ZXMN6A11C	Single	No	60	20	4.4	3.9	120	180	-	330 @ 40V	3 @ 5V	5.7	SOT223
ZXMN6A11Z	Single	No	60	20	3.6	2.6	120	180	-	330 @ 40V	3 @ 5V	5.7	SOT89
DMN6140L	Single	No	60	20	2.3	1.3	140	170	-	315 @ 40V	4.2 @ 5V	8.6	SOT23
ZXMN6A07Z	Single	No	60	20	2.5	2.6	250	350	-	166 @ 40V	1.65 @ 5V	3.2	SOT89
ZXMN6A07F	Single	No	60	20	1.4	0.806	250	350	-	166 @ 40V	1.65 @ 5V	3.2	SOT23
ZVN4306GV	Single	No	60	20	2.1	3	330	450 @ 5V	-	350 max @ 25V	-	-	SOT223
ZVN4306AV	Single	No	60	20	1.1	0.85	330	450 @ 5V	-	350 max @ 25V	-	-	E-Line
ZVN4306G	Single	No	60	20	2.1	3	330	450 @ 5V	-	350 max @ 25V	-	-	SOT223
ZVN4306A	Single	No	60	20	1.1	1.1	330	450 @ 5V	-	350 max @ 25V	-	-	E-Line
ZVN4206G	Single	No	60	20	1	2	1000	1500 @ 5V	-	100 max @ 25V	-	-	SOT223
ZVN4206GV	Single	No	60	20	1	2	1000	1500 @ 5V	-	100 max @ 25V	-	-	SOT223
ZVN4206A	Single	No	60	20	0.6	0.7	1000	1500 @ 5V	-	100 max @ 25V	-	-	E-Line
ZVN4206AV	Single	No	60	20	0.6	0.7	1000	1500 @ 5V	-	100 max @ 25V	-	-	E-Line
DMG1026UV	Dual	Yes	60	20	0.44	0.65	1800	2100	-	32 @ 25V	0.45	-	SOT563
DMN62D1SFB	Single	Yes	60	20	0.41	0.47	1400	1600	-	40 @ 40V	0.73	1.39	X1-DFN1006-3
DMN62D0LFB	Single	Yes	60	20	0.1	0.47	-	2000 @ 4V	2500	32 @ 25V	0.45	-	X1-DFN1006-3
DMN62D0LFD	Single	Yes	60	20	0.31	0.48	-	2000 @ 4V	2500	31 @ 25V	0.5	-	X1-DFN1212-3
DMN62D1LFD	Single	Yes	60	20	0.4	0.5	-	2000 @ 4V	2500	36 @ 25V	0.55	-	X1-DFN1212-3
DMN62D0SFD	Single	Yes	60	20	0.63	0.89	2000	3000 @ 5V	-	30.2 @ 25V	0.39	0.87	X1-DFN1212-3
ZVN2106A	Single	No	60	20	0.45	0.7	2000	-	-	75 max @ 18V	-	-	E-Line
ZVN2106G	Single	No	60	20	0.71	2	2000	-	-	75 max @ 18V	-	-	SOT223

51V – 99V N-CHANNEL (CONTINUED)



Part Number	Configuration	ESD Diode (Y/N)	V _{DS} (V)	V _{GS} (±V)	I _{DS} (A)	P _D (W)	R _{DS(ON)} (mΩ max) at V _{GS} =			C _{ISS} typ @ V _{GS} = ½V _{DSS} (pF)	Q _C typ @ V _{GS} = 4.5V (nC)	Q _C typ @ V _{GS} = 10V (nC)	Package
					@T _A =25°C	@T _A =25°C	10V	4.5V	2.5V				
ZVN4106F	Single	No	60	20	0.2	0.35	2500	5000 @ 5V	-	35 max @ 25V	-	-	SOT23
DMN601TK	Single	Yes	60	20	0.3	0.15	2000	3000 @ 5V	-	50 max @ 50V	-	-	SOT523
DMN601WK	Single	Yes	60	20	0.3	0.2	2000	3000	-	50 max @ 25V	-	-	SOT323
DMN601VK	Dual	Yes	60	20	0.305	0.25	2000	3000	-	50 max @ 25V	-	-	SOT563
DMN601DWK	Dual	Yes	60	20	0.305	0.2	2000	3000 @ 5V	-	50 max @ 25V	-	-	SOT363
DMN601K	Single	Yes	60	20	0.3	0.35	2000	3000 @ 5V	-	50 max @ 25V	-	-	SOT23
DMN601DMK	Dual	Yes	60	20	0.51	0.98	2400	4000 @ 5V	-	30 @ 25V	304	-	SOT26
DMN65D8LFB	Single	Yes	60	20	0.26	0.43	3000	4000	-	25 @ 25V	-	-	X1-DFN1006-3
DMN65D8L	Single	Yes	60	20	0.31	0.37	3000	4000 @ 5V	-	22 @ 25V	0.43	0.87	SOT23
DMN65D8LW	Single	Yes	60	20	0.3	0.43	3000	4000 @ 5V	-	22 @ 25V	0.43	0.87	SOT323
DMN66D0LW	Single	Yes	60	20	0.115	0.2	5000	6000 @ 5V	-	23 @ 25V	-	-	SOT323
DMN66D0LDW	Dual	Yes	60	20	0.115	0.25	5000	6000 @ 5V	-	23 @ 25V	-	-	SOT363
DMN66D0LT	Single	Yes	60	20	0.115	0.2	5000	6000 @ 5V	-	23 @ 25V	-	-	SOT523
DMN65D8LDW	Dual	Yes	60	20	0.2	0.4	6000	8000	-	22 @ 25V	0.43	0.87	SOT363
ZVN3306A	Single	No	60	20	0.27	0.625	5000	-	-	35 max @ 18V	-	-	E-Line
ZVN3306F	Single	No	60	20	0.15	0.33	5000	-	-	35 max @ 18V	-	-	SOT23
BS170F	Single	No	60	20	0.15	0.33	5000	-	-	60 @ 10V	-	-	SOT23
MMBF170	Single	No	60	20	0.5	0.3	5000	5300	-	22 @ 10V	-	-	SOT23
VNI0LF	Single	No	60	20	0.15	0.33	5000	7500 @ 5V	-	60	-	-	SOT23
VNI0LP	Single	No	60	20	0.27	0.625	5000	7500 @ 5V	-	60 max @ 25V	-	-	E-Line
BS870	Single	No	60	20	0.25	0.3	5000	-	-	22 @ 25V	-	-	SOT23
2N7002K	Single	Yes	60	20	0.38	0.54	2000	3000 @ 5V	-	30 @ 25V	0.3	-	SOT23
2N7002E	Single	No	60	20	0.25	0.37	3000	4000	-	22 @ 25V	223	-	SOT23
2N7002A	Single	Yes	60	20	0.18	0.37	5000	6000 @ 5V	-	23 @ 25V	-	-	SOT23
2N7002DWA	Dual	Yes	60	20	0.2	0.4	6000	8000	-	22 @ 25V	0.43	0.87	SOT363
2N7002W	Single	No	60	20	0.115	0.2	13500	7500 @ 5V	-	22 @ 25V	-	-	SOT323
2N7002	Single	No	60	20	0.21	0.54	13500	7500 @ 5V	-	22 @ 25V	223	-	SOT23
2N7002DW	Dual	No	60	20	0.23	0.4	13500	7500 @ 5V	-	22 @ 25V	-	-	SOT363
2N7002T	Single	No	60	20	0.115	0.15	13500	7500 @ 5V	-	22 @ 25V	-	-	SOT523
2N7002VAC	Dual	No	60	20	0.28	0.15	13500	7500 @ 5V	-	50 max @ 25V	-	-	SOT563
2N7002VC	Dual	No	60	20	0.28	0.15	13500	7500 @ 5V	-	50 max @ 25V	-	-	SOT563
ZXMN7A11G	Single	No	70	20	3.8	3.9	13	19	-	298 @ 40V	4.35 @ 5V	7.4	SOT23
ZXMN7A11K	Single	No	70	20	6.1	8.5	13	19	-	298 @ 40V	4.35 @ 5V	7.4	TO252 (DPAK)
DMN7022LFC	Single	No	75	20	10.5	2	22	28	-	2737 @ 35V	26.4	56.5	POWERDI3333-8
DMT8012LFC	Single	No	80	20	9.5	2.2	16	22 @ 6V	-	1949	15	34	POWERDI3333-8
DMT8012LK3	Single	No	80	20	10.5	2.6	16	21	-	1949	15	34	TO252 (DPAK)



60V MOSFET BOOSTS POWER DENSITY

THE DIODES ADVANTAGE

The DMN6070SFCL is the world's smallest 60V N-channel MOSFET with a sub-100mΩ on-resistance.

- Small footprint and low profile**
 Packaged in a DFN1616 with a footprint measuring 1.6mm x 1.6mm and a typical off-board height of only 0.5mm.
- Low on-resistance**
 With a typical R_{DS(ON)} of 74mΩ at V_{GS} of 4V to minimize conduction losses and raise overall power efficiency.

51V – 99V P-CHANNEL

Part Number	Configuration	ESD Diode (Y/N)	V _{DS} (V)	V _{GS} (±V)	I _{DS} (A)		P _D (W)			R _{DS(ON)} (mΩ max) at V _{GS} =			C _{ISS} typ @ V _{GS} = ½V _{DSS} (pF)	Q _C typ @ V _{GS} = 4.5V (nC)	Q _G typ @ V _{GS} = 10V (nC)	Package
					@T _A =25°C	@T _A =25°C	10V	4.5V	2.5V							
DMP6023LFG	Single	No	60	20	7.7	2.1	25	33	-	2569	26.5	53.1	POWERDI3333-8			
DMP6023LSS	Single	No	60	20	6.6	1.6	25	33	-	2569	26.5	53.1	SO-8			
DMP6023LE	Single	No	60	20	7.4	2	28	35	-	2569	26.5	53.1	SOT223			
DMP6050SSD	Dual	No	60	20	4.8	1.7	55	70	-	1293	11.9	24	SO-8			
ZXMP6A18K	Single	No	60	20	10.4	10.1	55	80	-	1580	23 @ -5V	44	TO252 (DPAK)			
ZXMP6A16K	Single	No	60	20	8.2	9.76	85	125	-	1021	12.1 @ -5V	24.2	TO252 (DPAK)			
DMP6110SSD	Dual	No	60	20	4.5	1.7	105	130	-	969	8.2	17.2	SO-8			
DMP6110SSS	Single	No	60	20	4.5	1.5	110	130	-	1030	9.5	19.4	SO-8			
DMP6180SK3	Single	No	60	20	10	2.7	110	140	-	984.7	8.1	17.1	TO252 (DPAK)			
ZXMP6A17DN8	Dual	No	60	20	3.4	2.15	125	190	-	637	9	17.7	SO-8			
ZXMP6A17E6	Single	No	60	20	3	1.9	125	190	-	637	9.8	17.7	SOT26			
ZXMP6A17G	Single	No	60	20	4.3	3.9	125	190	-	637	9	17.7	SOT223			
DMP6185SK3	Single	No	60	20	9.4	2.7	150	185	-	708	6.2	14	TO252 (DPAK)			
DMP6185SE	Single	No	60	20	3	2.2	150	185	-	708	6.2	14	SOT223			
DMP6250SE	Single	No	60	20	2.1	1.8	250	300	-	551	4.8	9.7	SOT223			
ZXMP6A13G	Single	No	60	20	2.3	3.9	390	595	-	219	2.9	5.9	SOT223			
ZXMP6A13F	Single	No	60	20	1.1	0.806	400	600	-	219	2.9	5.9	SOT23			
ZVP2106A	Single	No	60	20	0.28	0.7	5000	-	-	100	-	-	E-Line			
ZVP2106G	Single	No	60	20	0.45	2	5000	-	-	100	-	-	SOT223			
ZVP3306A	Single	No	60	20	0.16	0.625	14000	-	-	50	-	-	E-Line			
ZVP3306F	Single	No	60	20	0.09	0.33	14000	-	-	50	-	-	SOT23			
ZXMP7A17G	Single	No	70	20	3.7	3.9	160	250	-	635	9.6	18	SOT223			
ZXMP7A17K	Single	No	70	20	5.7	9.25	160	250	-	635	9.6	18	TO252 (DPAK)			

MOSFET PORTFOLIO OPTIMIZED FOR VOIP

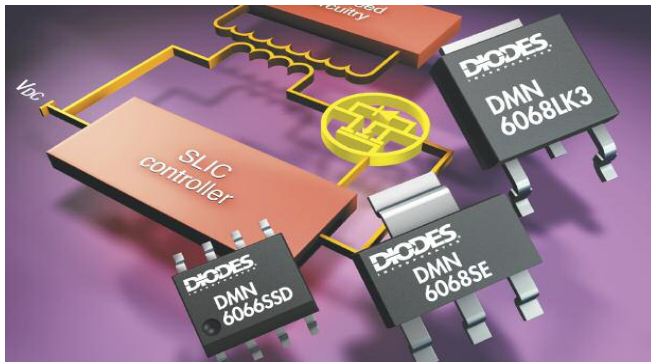

Did you know? Diodes Incorporated provides the designers of Voice over Internet Protocol (VoIP) communication equipment with a range of rugged MOSFETs that significantly reduces circuit complexity and cost. For example, DMN60xx series are designed to handle the high-pulse current needed to generate tip and ring linefeeds and to withstand the avalanche energy induced during switching. This meets the stringent requirements of primary switch position in transformer based Subscriber Line Interface Circuits (SLIC) DC/DC converters.

Diodes Incorporated also offers PNP transistors suitable for this application, e.g. the FZT953, FZT955.

THE DIODES ADVANTAGE

- High pulse current (I_{DM})**
 With high I_{DM} handling capabilities, the MOSFETs can drive the transformer to deliver the required RING and TIP currents.
- Avalanche rugged**
 These MOSFETs have been designed to withstand the high-pulse avalanche energy that will be induced by the transformer during switching transition.
- Low gate charge (Q_G) and input capacitance (C_{ISS})**
 This simplifies the SLIC design and reduces component count and cost. These MOSFETs are capable of being driven at low logic-level voltages.

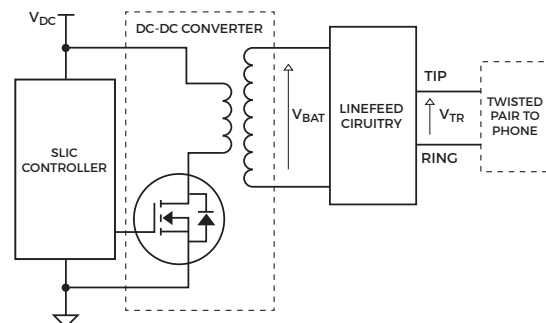

100V PLUS N-CANNEL



Part Number	Configuration	ESD Diode (Y/N)	V _{DS} (V)	V _{GS} (±V)	I _{DS} (A) @T _A =25°C	P _D (W) @T _A =25°C	R _{DS(ON)} (mΩ max) at V _{GS} =			C _{ISS} typ @ V _{GS} = ½V _{DSS} (pF)	Q _C typ @ V _{GS} = 4.5V (nC)	Q _C typ @ V _{GS} = 10V (nC)	Package
							10V	4.5V	2.5V				
DMN10H099SFG	Single	No	100	20	4.2	2.31	80	99 @ 6V	-	1127	12.2	25.2	POWERDI3333-8
DMN10H099SK3	Single	No	100	20	17	-	80	99 @ 6V	-	1172	12.2	25.2	TO252 (DPAK)
ZXMN10A09K	Single	No	100	20	7.7	10.1	85	100 @ 6V	-	1313	17.2 @ 6V	26	TO252 (DPAK)
DMN10H120SFG	Single	No	100	20	3.8	2.4	110	122 @ 6V	-	549	5.2	10.6	POWERDI3333-8
DMN10H170SFG	Single	No	100	20	2.9	2	122	133	-	870.7 @ 25V	7	14.9	POWERDI3333-8
ZXMN10A25C	Single	No	100	20	4	3.9	125	150 @ 6V	-	859	9.6 @ 5V	17	SOT223
ZXMN10A25K	Single	No	100	20	6.4	9.85	125	150 @ 6V	-	859	9.6 @ 5V	17	TO252 (DPAK)
DMN10H170SK3	Single	No	100	20	12	42	140	160	-	1167 @ 25V	4.9	9.7	TO252 (DPAK)
DMN10H220L	Single	No	100	16	1.6	1.3	220	250	-	401 @ 25V	4.1	8.3	SOT23
DMN10H220LE	Single	No	100	20	2.3	1.8	220	250	-	401 @ 25V	4.1	8.3	SOT223
ZXMN10B08E6	Single	No	100	20	1.9	1.7	230	300	-	497	5 @ 5V	9.2	SOT26
ZXMN10A08DN8	Dual	No	100	20	2.1	1.8	250	300 @ 6V	-	405	4.2 @ 5V	7.7	SO-8
ZXMN10A08E6	Single	No	100	20	1.9	1.7	250	300 @ 6V	-	405	4.2 @ 5V	7.7	SOT26
ZXMN10A08C	Single	No	100	20	2.9	3.9	250	300 @ 6V	-	405	4.2 @ 5V	7.7	SOT223
ZXMN10A11C	Single	No	100	20	2.4	3.9	350	450 @ 6V	-	274	3.5 @ 5V	5.4	SOT223
ZXMN10A11K	Single	No	100	20	3.5	8.5	350	450 @ 6V	-	274	3.5 @ 5V	5.4	TO252 (DPAK)
ZVN4310A	Single	No	100	20	0.9	0.85	500	650 @ 6V	-	350 max @ 25V	-	-	E-Line
ZVN4310G	Single	No	100	20	1.67	3	540	750 @ 6V	-	350 max @ 25V	-	-	SOT223
ZXMN10A07F	Single	No	100	20	0.8	0.625	700	900 @ 6V	-	138	-	2.9	SOT23
ZXMN10A07Z	Single	No	100	20	1.4	2.6	700	900 @ 6V	-	138	-	2.9	SOT89-3L
ZVN4210A	Single	No	100	20	0.45	0.7	1500	1800 @ 5V	-	100 max @ 25V	-	-	E-Line
ZVN4210G	Single	No	100	20	0.8	2	1500	1800 @ 5V	-	100 max @ 25V	-	-	SOT223
ZVNL110A	Single	No	100	20	0.32	0.7	3000	4500 @ 5V	-	75 max @ 25V	-	-	E-Line
ZVNL110G	Single	No	100	20	0.6	2	3000	4500 @ 5V	-	75 max @ 25V	-	1.8	SOT223
ZVN2110A	Single	No	100	20	0.32	0.7	4000	-	-	75 max @ 25V	-	-	E-Line
ZVN2110G	Single	No	100	20	0.5	2	4000	-	-	59 @ 25V	-	-	SOT223
BSS123	Single	No	100	20	0.17	0.3	6000	10000	-	29 @ 25V	-	-	SOT23
BSS123W	Single	No	100	20	0.17	0.2	6000	10000	-	29 @ 25V	-	-	SOT323
ZVN3310A	Single	No	100	20	0.2	0.625	10000	-	-	40 max @ 25V	-	-	E-Line
ZVN3310F	Single	No	100	20	0.1	0.33	10000	-	-	40 max @ 25V	-	-	SOT23
ZXMN15A27K	Single	No	150	25	2.6	9.5	650	-	-	169 @ 25V	-	6.6	TO252 (DPAK)
ZXMN20B28K	Single	No	200	20	2.3	10.2	750	780 @ 5V	-	358 @ 25V	8.1 @ 5V	-	TO252 (DPAK)
ZVN2120G	Single	No	200	20	0.32	2	10000	-	-	85 max @ 25V	-	-	SOT223
ZVN3320F	Single	No	200	20	0.06	0.33	25000	-	-	45 max @ 25V	-	-	SOT23
ZVNL120A	Single	No	200	20	0.18	0.7	-	10000 @ 5V	10000 @ 3V	85 max @ 25V	-	-	E-Line
ZVNL120G	Single	No	200	20	0.32	2	-	10000 @ 5V	10000 @ 3V	85 max @ 25V	-	-	SOT223
BS107P	Single	No	200	20	0.12	0.5	-	30000 @ 5V	23000 @ 2.6V	-	-	2.7	E-Line
ZVN4424A	Single	No	240	40	0.26	0.75	5500	-	6000	110 @ 25V	-	-	E-Line
ZVN4424G	Single	No	240	40	0.5	2.5	5500	-	6000	110 @ 25V	-	-	SOT223
DMN24H11DS	Single	No	240	20	0.27	1.2	11000	12000	-	76.8 @ 25V	-	3.7	SOT23
ZVN0124A	Single	No	240	20	0.16	0.7	16000	-	-	85 max @ 25V	-	-	E-Line
ZVN4525E6	Single	No	250	40	0.23	1.1	8500	9000	9500	72 @ 25V	-	2.6	SOT26
ZVN4525G	Single	No	250	40	0.31	2	8500	9000	9500	72 @ 25V	-	2.6	SOT223
ZVN4525Z	Single	No	250	40	0.24	1.2	8500	9000	9500	72 @ 25V	-	2.6	SOT89-3L
DMN30H4D0L	Single	No	300	20	0.25	0.47	4000	4000	-	187.3 @ 25V	-	7.6	SOT23
DMN30H4D0LFDE	Single	No	300	20	0.55	1.98	4000	4000	-	187.3 @ 25V	-	7.6	U-DFN2020-6 Type E
DMN30H14DLY	Single	No	300	20	0.21	2.2	14000	20000	-	96 @ 25V	-	4	SOT89
ZVN0540A	Single	No	400	20	0.09	0.7	50000	-	-	70 max @ 25V	-	-	E-Line
DMGD7N45SSD	Dual	No	450	30	0.5	1.64	4000	-	-	256 @ 25V	-	6.9	SO-8

100V PLUS N-CHANNEL (CONTINUED)



Part Number	Configuration	ESD Diode (Y/N)	V _{DS} (V)	V _{GS} (±V)	I _{DS} (A)		R _{DS(ON)} (mΩ max) at V _{GS} =			C _{ISS} typ @ V _{GS} = ½V _{DSS} (pF)	Q _C typ @ V _{GS} = 4.5V (nC)	Q _C typ @ V _{GS} = 10V (nC)	Package
					@T _A =25°C	@T _A =25°C	10V	4.5V	2.5V				
ZVN0545A	Single	No	450	20	0.09	0.7	50000	-	-	70 max @ 25V	-	-	E-Line
ZVN0545G	Single	No	450	20	0.14	2	50000	-	-	70 max @ 25V	-	-	SOT223
ZXMN0545G4	Single	No	450	20	0.14	2	50000	-	-	70 max @ 25V	-	-	SOT223
BSS127S	Single	No	600	20	0.07	1.25	160000	19000 @ 5V	-	21.8 @ 25V	-	1.08	SOT23
BSS127SSN	Single	No	600	20	0.07	1.25	160000	19000 @ 5V	-	21.8 @ 25V	-	1.08	SC59
DMG9N65CT	Single	No	650	30	9	165	1300	-	-	2310 @ 25V	-	39	TO220AB
DMG9N65CTI	Single	No	650	30	9	13	1300	-	-	2310 @ 25V	-	39	ITO-220AB
DMG4N65CT	Single	No	650	30	4	2.19	3000	-	-	900 @ 25V	-	13.5	TO220-3
DMG4N65CTI	Single	No	650	30	4	8.53	3000	-	-	900 @ 25V	-	13.5	ITO-220AB
DMJ7N70SK3	Single	No	700	30	3.9	28	1250	-	-	351 @ 50V	-	14	TO252 (DPAK)

100V PLUS P-CHANNEL



Part Number	Configuration	ESD Diode (Y/N)	V _{DS} (V)	V _{GS} (±V)	I _{DS} (A)		R _{DS(ON)} (mΩ max) at V _{GS} =			C _{ISS} typ @ V _{GS} = ½V _{DSS} (pF)	Q _C typ @ V _{GS} = 4.5V (nC)	Q _C typ @ V _{GS} = 10V (nC)	Package
					@T _A =25°C	@T _A =25°C	10V	4.5V	2.5V				
ZXMP10A18G	Single	No	100	20	3.7	3.9	150	190 @ 6V	-	1055	-	26.9	SOT223
ZXMP10A18K	Single	No	100	20	5.9	10.2	150	190 @ 6V	-	1055	-	26.9	TO252 (DPAK)
ZXMP10A16K	Single	No	100	20	4.6	9.76	235	285 @ 6V	-	717	-	16.5	TO252 (DPAK)
DMP10H400SK3	Single	No	100	20	9	42	240	300	-	1239 @ 25V	8.4	17.5	TO252 (DPAK)
ZXMP10A17E6	Single	No	100	20	1.6	1.7	350	450 @ -6V	-	424	7.1 @ -6V	10.7	SOT26
ZXMP10A17G	Single	No	100	20	2.4	3.9	350	450 @ -6V	-	424	7.1 @ -6V	10.7	SOT223
ZXMP10A17K	Single	No	100	20	3.9	10.2	350	450 @ -6V	-	424	7.1 @ -6V	10.7	TO252 (DPAK)
ZXMP10A13F	Single	No	100	20	0.7	0.806	1000	1450 @ -6V	-	141	1.8 @ 5V	3.5	SOT23
ZVP2110A	Single	No	100	20	0.23	0.7	8000	-	-	100 max @ 25V	-	-	E-Line
ZVP2110G	Single	No	100	20	0.31	2	8000	-	-	100 max @ 25V	-	-	SOT223
ZVP3310A	Single	No	100	20	0.14	0.625	20000	-	-	50 max @ 25V	-	-	E-Line
ZVP3310F	Single	No	100	20	0.075	0.33	20000	-	-	50 max @ 25V	-	-	SOT23
ZVP2120A	Single	No	200	20	0.12	0.7	25000	-	-	100 max @ 25V	-	-	E-Line
ZVP2120G	Single	No	200	20	0.2	2	25000	-	-	100 max @ 25V	-	-	SOT223
ZXMP2120G4	Single	No	200	20	0.2	2	25000	-	-	100 max @ 25V	-	-	SOT223
ZXMP2120E5	Single	No	200	20	0.122	0.75	28000	-	-	100 max @ 25V	-	-	SOT25
ZXMP2120FF	Single	No	200	20	0.137	1	28000	-	-	100 max @ 25V	-	-	SOT23F
ZVP1320F	Single	No	200	20	0.035	0.35	80000	-	-	50 max @ 25V	-	-	SOT23
ZVP4424A	Single	No	240	40	0.2	0.75	9000	-	11000 @ 35V	100 max @ 25V	-	-	E-Line
ZVP4424G	Single	No	240	40	0.48	2.5	9000	-	11000 @ 35V	100 max @ 25V	-	-	SOT223
ZVP4424Z	Single	No	240	40	0.2	1.5	9000	-	11000 @ 35V	100 max @ 25V	-	-	SOT89-3L
ZVP4525E6	Single	No	250	40	0.197	1.1	14000	-	18000 @ 35V	73 @ 25V	-	2.45	SOT26
ZVP4525G	Single	No	250	40	0.265	2	14000	-	18000 @ 35V	73 @ 25V	-	2.45	SOT223
ZVP4525Z	Single	No	250	40	0.205	1.2	14000	-	18000 @ 35V	73 @ 25V	-	2.45	SOT89-3L
ZVP0545A	Single	No	450	20	0.045	0.7	150000	-	-	120 max @ 25V	-	-	E-Line
ZVP0545G	Single	No	450	20	0.075	2	150000	-	-	120 max @ 25V	-	-	SOT223

PROTECTED MOSFETS (IntelliFET)

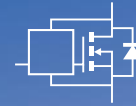

Part Number	Configuration	TAB	BV _{DSS} (V)	I _D (A) V _{IN} =5V	P _D (W) @T _A =+25°C	R _{DS(ON)} (mΩ max) at V _{GS} =			V _{DS(S/C)} 5V	E _{AS} (mJ)	T _J (°C)	Package
						3V	5V	10V				
ZXMS6006DG	Single	Drain	60	2.8	3	125	100	-	36	490	150	SOT223
ZXMS6006DT8	Dual	N/A	60	-	2.1	125	100	-	36	210	150	SM-8
ZXMS6006SG	Single	Source	60	2.8	3	125	100	-	36	490	150	SOT223
ZXMS6005DG	Single	Drain	60	2	3	250	200	-	24	490	150	SOT223
ZXMS6005DT8	Dual	N/A	60	1.8	2.13	250	200	-	24	210	150	SM-8
ZXMS6005SG	Single	Source	60	2	1.6	250	200	-	24	480	150	SOT223
ZXMS6004DG	Single	Drain	60	1.3	3	600	500	-	36	490	150	SOT223
ZXMS6004DT8	Dual	N/A	60	1.2	2.13	600	500	-	36	210	150	SM-8
ZXMS6004FF	Single	N/A	60	1.3	1.5	600	500	-	36	90	150	SOT23F
ZXMS6004SG	Single	Source	60	1.3	1.6	600	500	-	36	480	150	SOT223
BSP75G	Single	Drain	60	1.4	2.5	-	675	550	36	550	150	SOT223
BSP75N	Single	Source	60	1.2	1.5	-	675	550	36	550	150	SOT223
ZXMS6001N3	Single	Source	60	1.1	1.5	2000	675	-	36	550	150	SOT223
ZXMS6002C	Single	Drain	60	1.4	2.5	-	675	550	36	550	150	SOT223
ZXMS6003C	Single	Drain	60	1.4	2.5	-	675	550	36	550	150	SOT223

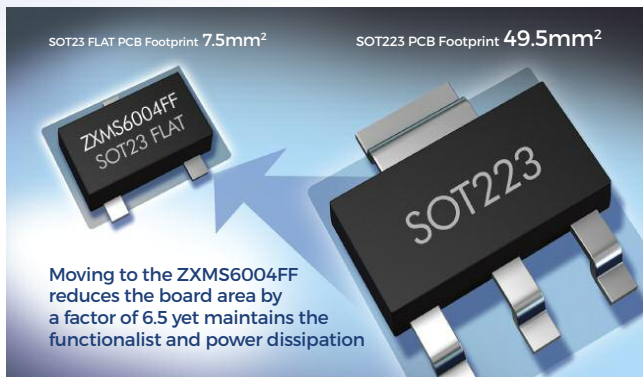

Did you know? The IntelliFET® series of low-side 60V N-channel MOSFETs feature over-current, over-voltage, over-temperature and ESD protection that enables circuit designers to increase system reliability.

The ZXMS6004FF is probably the smallest self-protected MOSFET that is ideally suited for switching inductive loads, such as motors, relays and lamps at low frequencies.

Packaged in the thermal efficient and compact SOT23 flat (SOT23F), this takes 85% less board space than 7.3mm x 6.7mm footprint SOT223 packaged parts. The small footprint of ZXMS6004FF opens new applications such as sensors where PCB constraints had previously prevented the use of self-protected MOSFETs.

PROBABLY THE SMALLEST SELF-PROTECTED MOSFET

THE DIODES ADVANTAGE

IntelliFETs are low-side 60V N-channel MOSFETs with integrated self-protection features.

- **Self-protected MOSFETs**
IntelliFET portfolio feature over-current, over-voltage, over-temperature and ESD protection that increase system reliability.
- **Logic-level input**
IntelliFETs can be driven directly from microcontrollers with logic level signals from 3.3V to 5V.
- **ZXMS6004FF in SOT23F**
Providing power density three times that of equivalent SOT223 solutions, the ZXMS6004FF saves on board space having an equivalent footprint to standard SOT23.
- **Dual IntelliFETs in SM8**
Co-packaging two IntelliFETs as independent and isolated switches enables one dual SM8 to replace two SOT223 while delivering the same thermal performance and reducing PCB area.
- **Automotive AEC-Q101**
Fully meets AEC-Q101 standard for high reliability, making IntelliFETs well-suited for operation in harsh environments.

IntelliFET is a registered trademark of Diodes Incorporated.

H-BRIDGE

Part Number	Configuration	Type	ESD Diode (Y/N)	V _{DS} (V)	V _{GS} (±V)	I _{DS} (A)	P _D (W)	R _{DS(ON)} Max(mΩ) at V _{GS} =		C _{ISS} typ @ V _{GS} = ½V _{DSS} (pF)	Q _C typ @ V _{GS} = 4.5V (nC)	Q _C typ @ V _{GS} = 10V (nC)	Package
						@T _A =+25°C		@T _A =+25°C	10V				
DMHC3025LSD	H-bridge	2*N	No	30	20	6	1.5	25	40	590	5.4	11.7	SO-8
		2*P				4.2		50	80	631	5.5	11.4	
ZXMHC3F381N8	H-bridge	2*N	No	30	20	5	1.35	33	60	430	-	9 @ 15V	SO-8
		2*P				4.1		55	80	670	-	12.7 @ 15V	
ZXMHC3A01T8	H-bridge	2*N	No	30	20	3.1	1.7	120	180	190 @ 25V	-	3.9	SM-8
		2*P				2.3		210	330	204 @ 15V	-	5.2	
ZXMHC3A01N8	H-bridge	2*N	No	30	20	2.7	1.36	125	180	190 @ 25V	-	3.9	SO-8
		2*P				2.1		210	330	204 @ 15V	-	5.2	
DMHC4035LSD	H-bridge	2*N	No	40	20	4.5	1.5	45	58	574	5.9	12.5	SO-8
		2*P				3.7		65	100	587	5.4	11.1	
ZXMHC6A07N8	H-bridge	2*N	No	60	20	1.8	1.36	250	350	166 @ 40V	-	3.2	SO-8
		2*P				1.4		400	600	141 @ 50V	-	5.1	
ZXMHC6A07T8	H-bridge	2*N	No	60	20	1.8	1.7	300	450	166 @ 40V	1.65 @ 5V	3.2	SM-8
		2*P				1.5		425	630	233 @ 30V	2.4 @ 5V	5.1	
ZXMHN6A07T8	H-bridge	4*N	No	60	20	1.6	1.4	300	450	166 @ 40V	-	3.2	SM-8
ZXMHC10A07N8	H-bridge	2*N	No	100	20	1	1.36	700	900 @ 6V	138 @ 60V	-	2.9	SO-8
		2*P				0.9		1000	1450 @ 6V	141 @ 50V	-	3.5	
ZXMHC10A07T8	H-bridge	2*N	No	100	20	1.1	1.3	700	900 @ 6V	138 @ 60V	-	2.9	SM-8
		2*P				0.9		1000	1450 @ 6V	141 @ 50V	-	3.5	

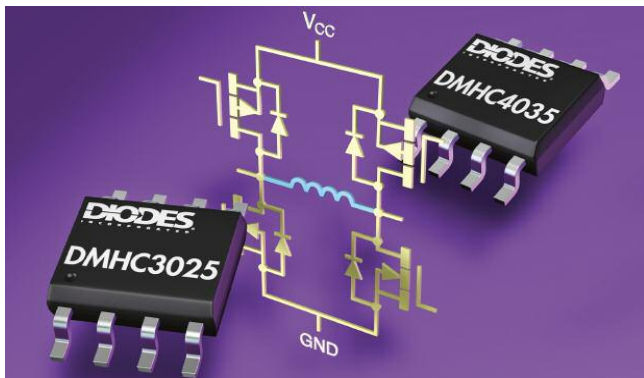

Did you know? Packaging dual N-channel and dual P-channel MOSFETs in an SO-8 package, Diodes Incorporated has provided a unique solution that enables designers to reduce the PCB space and component count required by low power, full H-bridge applications.

In just a single SO-8, with 5mm x 6mm footprint, these H-bridges can replace the equivalent four SOT23 or two SO-8 in space limited single-phase brush and brushless motor driving, inductive wireless charging circuits, CCFL inverters and driving solenoids in relays.

The H-bridges' space-saving advantage is complemented by the low R_{DS(ON)} performance of the MOSFETs, typically 45mΩ at 10V V_{GS} and 65mΩ at -10V V_{GS} respectively for the 40V N-channel and P-channel devices. The minimal conduction losses resulting from the low on resistance mean the H-bridge is able to tolerate higher continuous current under motor stall conditions.

MOSFET H-BRIDGES REDUCE FOOTPRINT BY 50%

THE DIODES ADVANTAGE

- Reduce footprint**
 Using single SO-8 package, with 5mm x 6mm footprint, these H-bridges can save PCB space, reduce component count and assembly costs.
- Low R_{DS(ON)}**
 <50mΩ minimizes conduction losses enabling the H-bridges to tolerate high continuous current under motor stall conditions.
- High pulsed current**
 30A peak pulse capability allows for a high in-rush current to be drawn safely during the start-up of the inductive load.
- Max drain voltage**
 40V and 30V V_{DSS} provides sufficient headroom for the intended 24V and 12V V_{CC} rail voltages.

Typical 12V full H-bridge driving a brushed DC motor

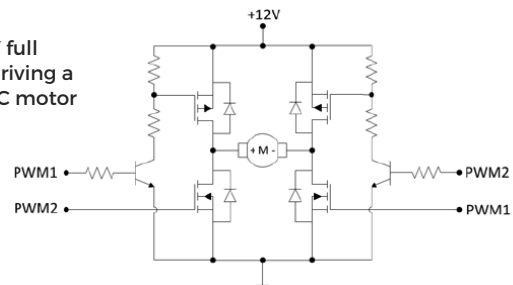

HIGH TEMPERATURE AUTOMOTIVE 'Q' MOSFETS

Part Number	Polarity	V _{DS} (V)	V _{GSS} (V)	I _D (A)	V _{GSTH} (V)	R _{DS(ON)} max (mΩ)		Q _{GT} Typ @V _{GS} = 10 V (nc)	Typ C _{ISS} (pf) @25V _{DSS}	E _{AR} (mJ)	I _{AR} (A)	T _J max	Package	Availability
						@10V	@4.5V							
DMTH4004SCTBQ	N	40	20	100	2-4	3.4	-	69	3750	200	45	175	TO252 (DPAK)	Q4 2015*
DMTH4004LK3Q	N	40	20	100	2-4	2.5	3.6	83	4450	120	30	175	TO252 (DPAK)	Q4 2015*
DMTH4004SPSQ	N	40	20	100	2-4	2.7	-	60.1	3714	200	45	175	POWERDI5060-8	Q4 2015*
DMNH4006LK3Q	N	40	20	80	2-4	5	-	54	2492	260	70	175	TO252 (DPAK)	Q4 2015*
DMNH4006LPSQ	N	40	20	80	2-4	5	-	54	2492	260	70	175	POWERDI5060-8	Q4 2015*
DMTH4007LPSQ	N	40	20	100	1-3	6.5	9.8	41	2090	64	20	175	POWERDI5060-8	Q4 2015*
DMTH4007LK3Q	N	40	20	50	1-3	7.5	11.5	41	2090	64	20	175	TO252 (DPAK)	Q4 2015*
DMTH4007SPD	N+N	40	20	-	2-4	8.6	-	41	2026	89	24	175	POWERDI5060-8	Q4 2015*
DMNH4011LK3Q	N	40	20	50	2-4	10	-	25.5	1374	170	18	175	TO252 (DPAK)	Q4 2015*
DMNH4011LPSQ	N	40	20	20	2-4	10	-	25.5	1374	170	18	175	POWERDI5060-8	Q4 2015*
DMTH6003SCTBQ	N	60	20	100	2-3	2.4	-	TBC	TBC	TBC	TBC	175	TO252 (DPAK)	Q4 2015*
DMTH6004SPSQ	N	60	20	95	2-4	3.1	-	68.7	4221	200	45	175	POWERDI5060-8	Q4 2015*
DMTH6004SCTBQ	N	60	20	100	2-4	3.4	-	70.3	4221	200	45	175	TO252 (DPAK)	Q4 2015*
DMTH6004SK3Q	N	60	20	95	2-4	3.8	-	70.3	4221	200	45	175	TO252 (DPAK)	Q4 2015*
DMTH6005LK3Q	N	60	20	80	1-3	4.8	8.2	37	6300	68	90	175	TO252 (DPAK)	Q4 2015*
DMTH6005LPSQ	N	60	20	80	1-3	4.8	8.2	37	6300	68	90	175	POWERDI5060-8	Q4 2015*
DMNH6008SPSQ	N	60	20	50	2-4	8	-	75.4	3290	300	26	175	POWERDI5060-8	Q4 2015*
DMTH6010LK3Q	N	60	20	50	1-3	8	12	41.3	2090	64	20	175	TO252 (DPAK)	Q4 2015*
DMTH6010SPSQ	N	60	20	20	1-3	8	12	41.3	2090	64	20	175	POWERDI5060-8	Q4 2015*
DMNH6012SPSQ	N	60	20	20	2-4	11	-	48.5	2221	168	58	175	POWERDI5060-8	Q4 2015*
DMNH6012LK3Q	N	60	20	50	1-3	12	18	48.5	2221	168	58	175	TO252 (DPAK)	Q4 2015*
DMNH6021SPDQ	N	60	20	40	1-3	23	28	19.7	1030	68	37	175	POWERDI5060-8	Q4 2015*
DMNH6021SK3Q	N	60	20	40	1-3	23	28	19.7	1030	68	37	175	TO252 (DPAK)	Q4 2015*
DMNH6022SSDQ	N	60	20	16	1-3	23	28	19.7	1030	68	37	175	SO-8	Q4 2015*
DMNH6042SPDQ	N	60	20	7	1-3	50	65	15.6	700	106	5	175	POWERDI5060-8	Q4 2015*
DMNH6042SSDQ	N	60	20	18	1-3	50	65	15.6	700	106	5	175	SO-8	Q4 2015*
DMNH6042SK3Q	N	60	20	18	1-3	50	65	15.6	700	106	5	175	TO252 (DPAK)	Q4 2015*
DMNH10H014LPSQ	N	100	20	TBC	2-4	14	24	50	3000	TBC	TBC	175	POWERDI5060-8	Q4 2015*
DMNH10H014LK3Q	N	100	20	TBC	2-4	14	24	50	3000	TBC	TBC	175	TO252 (DPAK)	Q4 2015*
DMNH10H028SPSQ	N	100	20	50	1.2-2.2	26	32	20	1500	102	44	175	POWERDI5060-8	Q4 2015*
DMNH10H028SK3Q	N	100	20	50	1.2-2.2	26	32	20	1500	102	44	175	TO252 (DPAK)	Q4 2015*
DMPH3010LK3Q	P	-30	20	-17.5	-1-2.2	7.5	10	126	6234	292	-24	175	TO252 (DPAK)	Q4 2015*
DMPH4015LSSQ	P	-40	20	-20	-1-2.3	11	15	91	4234	58	-34	175	SO-8	Q4 2015*
DMPH4013LSSQ	P	-40	20	-10	-1-2.4	13	18	-	3428	58	-34	175	SO-8	Q4 2015*
DMPH4023LSSQ	P	-40	20	-50	-1-2.5	22	30	TBC	TBC	TBC	TBC	175	SO-8	Q4 2015*
DMPH6050FCQ	P	-60	20	-17	-1-3	24	50	70	1293	31	-24	175	PowerDI3333-8	Q4 2015*
DMPH6050SK3Q	P	-60	20	-17	-1-3	24	50	70	1293	31	-24	175	TO252 (DPAK)	Q4 2015*

*Advance Information: For more details contact Diodes Sales

MOSFET PACKAGE EVOLUTION

SMALL SIGNAL

POWER

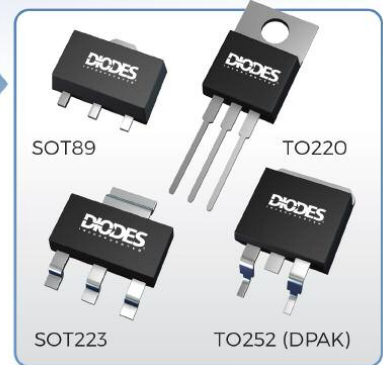
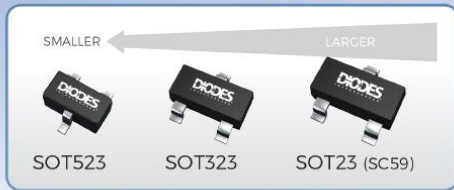

MOSFET PACKAGES





**CORPORATE HEADQUARTERS
AND AMERICAS SALES OFFICE**

4949 Hedgcoxe Road
Suite 200
Plano, Texas 75024
972-987-3900 USA
E-mail: inquiries@diodes.com

EUROPE SALES OFFICE

Kustermann-Park
Balanstrasse 59, 8th Floor
D-81541 Munchen, Germany
Tel: (+49) 89 45 49 49 0
E-mail: inquiries-europe@diodes.com

ASIA SALES OFFICES

Email: inquiries-asia@diodes.com

DIODES-TAIWAN

7F, No. 50, Min-Chuan Road
Hsin-Tien District
New Taipei City 23141
Taiwan, R.O.C.
Tel: 011-886-2-8914-6000

SHANGHAI OFFICE

Room 3001-3002,
International Corporate City, No. 3000
Zhongshan North Road,
Shanghai 200063, China
Tel: 86 21-5241-4882

SHENZHEN OFFICE

16th Floor Skyworth Semiconductor
Design Building East Wing,
No.8 Gaoxin South 4th Road,
Nanshan District, Shenzhen,
China P.C: 518057
Tel: 86 755-8828-4988

DIODES-KOREA

1601 ho, ParkView Tower
Jeongja 1 dong, Bundang-gu
Seongnam-si, Gyeonggi-do,
Korea 463-811
Tel: 82-31-786-0434

For information or literature,
please visit www.diodes.com/contacts

A large, stylized globe graphic in shades of blue, showing the continents. It is positioned in the lower half of the page, behind the website address and footer text.

diodes.com