

Scope

Virtually any electronic device needs proper layout, grounding and power supply bypassing. The MLX90614 IR thermometers have simple requirements in this aspect. These are described in the following document.

Decoupling

The MLX90614 is a mixed signal device that operates with small sensor signals. The digital part of the device generates switching noise. However, the MLX90614 is a low power device, designed with care for low noise and this noise can be easily nullified with a single capacitor on the power supply pin.

The 5 volt supply voltage version – the MLX90614Axx - uses internal voltage regulators. Their Power Supply Rejection is beneficial in noisy systems.

There are two basic modes of operation of the MLX90614 – SMBus and PWM. (Thermal relay mode uses the same application circuits as PWM.) PWM is free running, with only one output pin and is thus more robust to conducted noise. The application schematic of the MLX90614 in **PWM** mode is shown on Fig. 1.

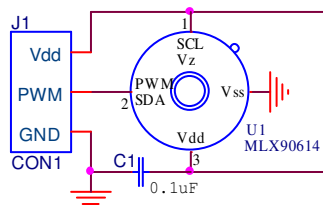

Fig. 1 MLX90614 in PWM output mode application circuit

C1 is the power supply bypass capacitor. It is almost industry standard to use 100nF here and this is fine for MLX90614. SMD ceramic capacitors are preferred.

This capacitor closes both the internal switching noise of the MLX90614 and power supply rail noise. Severe noise on the power rail will certainly need even better decoupling.

The PWM mode can be used in open drain or push-pull output. When push-pull is selected, loading of the PWM output drains current from the MLX90614 power supply (Vdd pin) and adds ripple on this node.

Capacitive loading on the PWM line can also add peak loading with more high frequency components. However, the typical load for the PWM pin is an MCU CMOS input which does not load the PWM pin significantly and causes no additional noise issue.

When long wires are present, one can use a series resistor like shown on Fig. 2. In this case a lower PWM frequency is preferred as the slew rate of the edges is reduced.

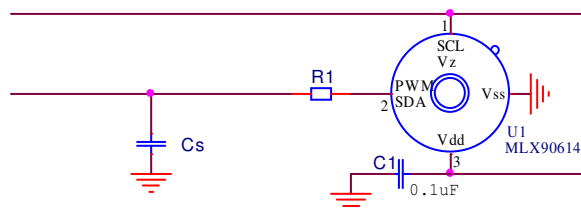

Fig. 2 Series resistor on PWM limits current peaking with long wires

Cs represents the line capacitance. The time resolution needed by the PWM capture unit is 11 bit – this means that the sampling frequency needs to be 1/2048 of the PWM period. If this

condition is not met, the originally 10 bit resolution of the PWM data will be degraded. Thus, the time product $R1.Cs$ must be below $T/2048$. With 0.1024 seconds (the largest PWM period for single zone MLX90614s) this gives 50 μs . If the PWM line is 5 meters long and has a capacitance of 150 pF/m, R1 should not exceed 62 kOhm.

The SMBus mode of operation is less tolerant to noise. The MLX90614 is always a slave device on the SMBus. Logic levels need to be assigned for reliable communication and significant additional noise could cause problems. The SMBus application circuit is shown in Fig. 3.

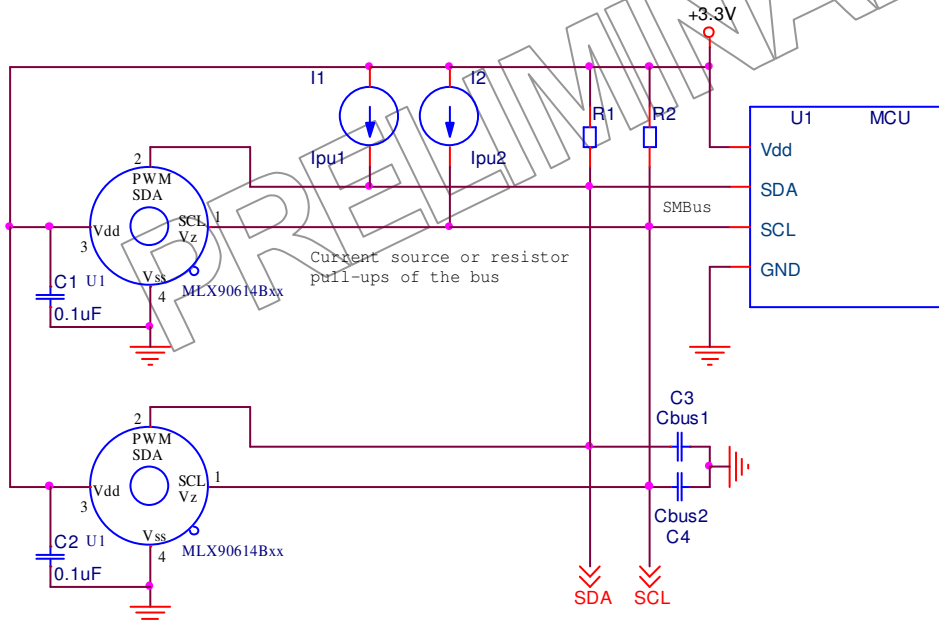

Fig. 3 MLX90614 SMBus application circuit

In a typical application, the same 100nF capacitor is fine. The SMBus lines enter the IC die in the MLX90614 and this creates an additional path for noise coupling. In most cases, the metal package of the device is a good shield, but the two lines SCL and SDA penetrate this shield. In spite of the EMC design some coupling is always possible within a high EMI environment. The SMBus is not designed for large networks, so the PWM configuration is preferred when EMI issues are expected.

Some applications can have specific noise requirements. Switching circuits (like switching power supplies), DSP systems and RF applications may demand special care for decoupling and filtering. However, there are many filters commercially available, like the feedthrough capacitor NFM21PC105 from Murata. The use of this component for power supply noise decoupling is shown on Fig. 4.

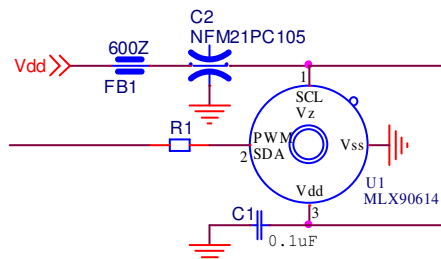

Fig. 4 Filtering power supply

Layout

General EMC rules apply for the MLX90614 layout.

The power supply bypass capacitor needs to be close to both Vdd and Vss pins of the device.

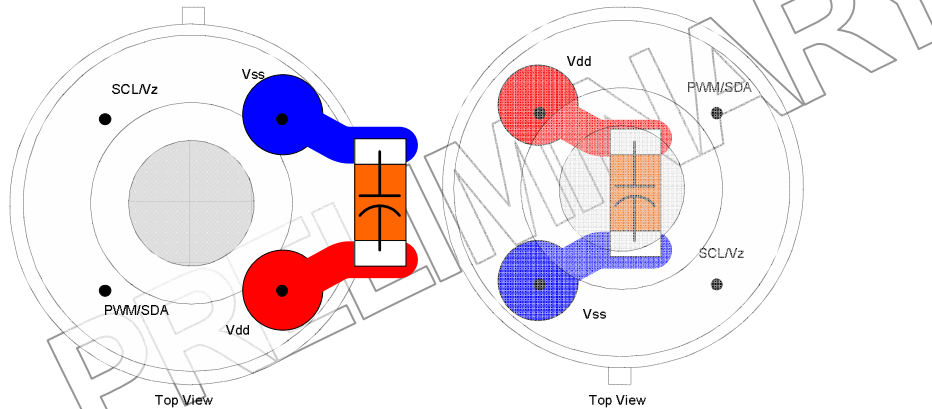

Fig. 5 Keep the power supply bypass capacitor close to the Vdd and Vss pins

Traces to that capacitor should be short and wide. Supply decoupling needs to be effective for RF and added inductance constrains the performance of the capacitor. For the same reason through hole components are not recommended for decoupling. Electrolytic capacitors are not effective for high frequencies, but paralleling them with appropriate ceramic capacitors is beneficial in wider frequency range.

PCB design for EMC often uses ground planes. This technique is simple and effective with MLX90614 as shown on Fig. 6.

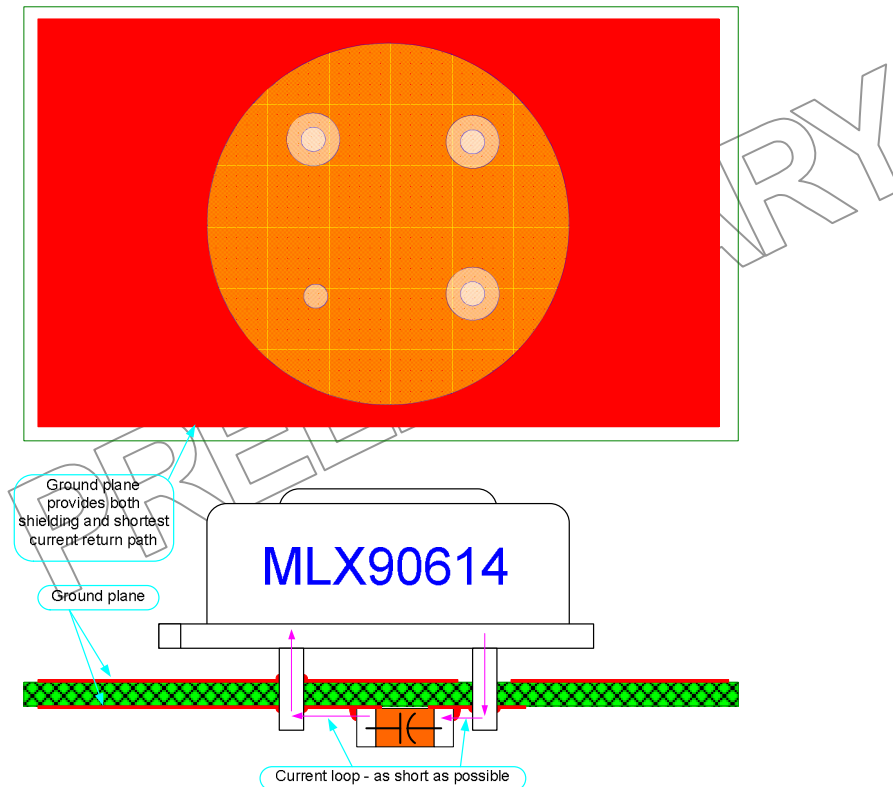

Fig. 6 Ground plane (minimum etch) design with MLX90614

As the ripple and noise on the power supply are currents, they travel through closed paths. This means that the currents need to return to their source after getting to the capacitor “hot” plate. Therefore a capacitor with only the “hot” plate close to the Vdd pin would not be as effective as a capacitor with both plates routed as short as possible to the Vdd **and** Vss pins. However, a ground plane has a low impedance and is closer to the schematic representation of ground. Return currents in a ground plane travel through the shortest way they can find. Keeping the current loop short (also enclosing minimum surface) minimizes both the impedance and the antenna effectiveness and is a must for proper EMC design. The ground planes are not just improving EMC of the MLX90614, but they also reduce noise generated by other components. Slots on ground planes are desired only in specific cases, like

- heat generation on the PCB is significant – the MLX90614 is a thermal sensor and subjecting it to heat transfer affects the measurement accuracy
- severe noise needs to be shielded in a separate part of the PCB
- ground loops must be managed through separation

PCB traces also cut the ground plane. When a whole layer can be dedicated to ground plane one achieves the most effective ground plane.

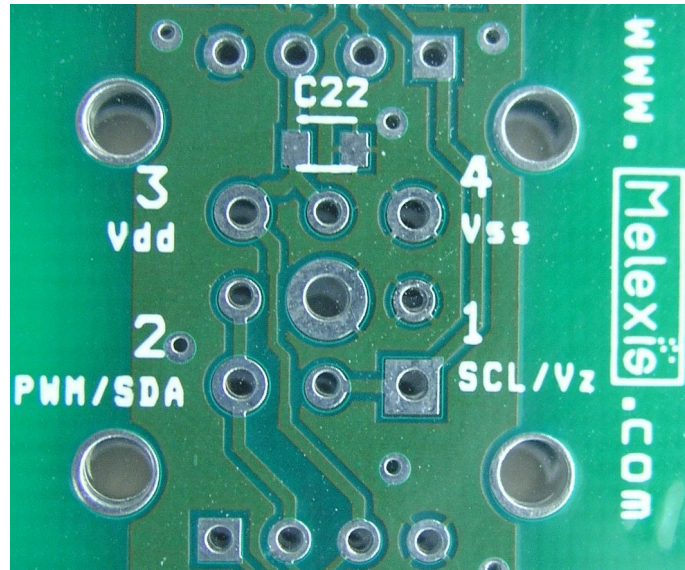

Fig. 7 Ground plane design

A ground plane design with the MLX90614 is shown in Fig. 7. The power supply bypass capacitor is C22.

The metal can of the MLX90614 is connected to the Vss pin. It is not recommended to connect ground to more than just the Vss pin as ground loops can sometimes induce noise in the internal circuitry.

Most ICs which use embedded power-on management (like Reset, MCU initialization, embedded calibrations etc.) are more sensitive to noise during the power-up period. The MLX90614 is no exception. Therefore, in systems with severe noise sources it is recommended to power-up the MLX90614 in advance of these sources.

Conclusion

The MLX90614 IR thermometers are not highly demanding regarding power supply decoupling, grounding and layout. Unlike other mixed and low signal devices all they need is a single ceramic capacitor close to the power and ground pins. The metal can package is beneficial for EMC in a wide frequency range. The MLX90614 is a low power device and generates very little noise.

It is virtually impossible to provide an EMI solution that is appropriate in all cases. Specific EMI can demand more sophisticated solutions, but most applications can adopt the MLX90614 with very little effort.