

Strategies for High Volume, High Quality, Low Cost Optical Sensors The Automotive Case

Cliff De Locht^{*}, Sven De Knibber, Sam Maddalena
Melexis Tessenderlo NV, Transportstraat, 1, B-3980 Tessenderlo, Belgium

ABSTRACT

Optical sensors for the automotive industry need to be robust, high performing and low cost. This paper focuses on the impact of automotive requirements on optical sensor design and packaging.

Main strategies to increase adoption of optical sensors in the automotive market include:

- Perform sensor calibration and tuning by the sensor manufacturer
- Include sensor test modes on chip to allow verification of functional integrity in the field
- Robust and capable package technology

As a conclusion, optical sensor applications are growing in automotive. Optical sensor robustness is maturing to level capable of supporting safety critical applications. Optical linear array based systems are currently deployed in Electrical Power Assisted Steering (EPAS) and Drive-by-Wire systems. Camera or imaging chips are critical components in Automated Cruise Control (ACC), Lane Change Assist and Driver Classification/Smart Airbag Deployment systems.

Keywords: optical sensors, integrated sensors, automotive, CMOS, robust, open cavity, package, test modes, zapping, EPAS, Drive-by-Wire, optical switch, light-to-voltage, light-to-frequency, linear arrays, camera, imager, time-of-flight.

1. INTRODUCTION

Automotive requirements for sensors are robustness, high performance and low cost. Especially because of robustness reasons, the use of optical sensors in automotive lagged behind the use of other sensor technologies like Hall Effect sensors, MEMS type sensors and pressure sensors.

Continuous efforts for improving robustness in every step of optical sensor development recently resulted in using optical sensors in safety critical automotive applications. This is achieved by considering automotive requirements in all steps of optical sensor chip development:

- Design
- Lay-out
- Wafer processing
- Packaging
- Probing and testing
- Module building

^{*} cliff.de.locht@melexis.com; www.melexis.com

In this paper we will focus on the impact of automotive requirements on optical sensor design and package choice.

We conclude by listing optical sensor based automotive applications and examining in detail Electrical Power Assisted Steering (EPAS) and Drive-by-Wire applications.

2. IMPACT OF “LOW COST” REQUIREMENTS ON SENSOR DESIGN

On the technology level, monolithic solutions are inherently low cost. These solutions imply the design of mixed signal electronics where the optical active area and the sensor interface electronics analog and digital circuits are integrated on one chip.

2.1 Design for Test

A considerable cost factor for automotive sensors is test time. This is because the automotive quality reference targets a level of 1 ppm. The two main implications are:

- Maintain full process control at the silicon foundry and at packaging
- Mandatory 100% optical and electrical testing at cold, ambient and hot conditions of every individual sensor

To minimize test time, adding additional test nodes is good practice to isolate functional building blocks during probing and testing. Parallel device testing further decreases test time.

2.2 Sensor Fusion

At the application level, OEM's prefer integrating multiple applications with one sensor to save costs. This implies that sensor specification input comes from multiple automotive applications, often with conflicting requirements.

Examples of sensor fusion for optical sensors are rain/light sensors and the front vision cameras. A rain/light sensor combines rain detection for wiper control with twilight and tunnel detection for automated headlight control. A front vision camera can be used for multiple functions like night vision, automated cruise control, lane departure warning, obstacle detection, road sign detection and parking assist.

3. IMPACT OF “ROBUSTNESS” REQUIREMENTS ON SENSOR DESIGN

Robust sensors are a must for automotive applications. Multiple design actions need to be implemented in the (integrated) sensor interface to improve robustness of a “naked” photodiode function. This chapter gives examples for the following strategies:

- Test pixels
- Zebra pattern testing
- Temperature sensor on chip
- Digital output communication redundancy
- Design Failure Mode and Effect Analysis (DFMEA)

Last but not least, robustness needs at the application level can have a strong impact on design. Two examples are given: a robust optical switch function and high resistance values for external components

3.1 Adding Test Pixels

A ‘bright’ test pixel can be used in the application as an integrity check during every integration cycle. The output value is then checked over consecutive read-outs. Monitoring this value allows a check if the sensor is working correctly.

Also a ‘dark’ test pixel can be used. This is a pixel like all others, except that no light energy falls onto the photodiode. As a result no photocurrent is generated or integrated.

3.2 Zebra Pattern Testing

The goal of zebra testing is to check the sensor function end-to-end without applying light on the photo active area. Instead, known charges are locally injected in the photodiode node area and read out. The figure below illustrates 4 runs of a zebra test measurement on a 172 pixel linear optical array. In this example, the even pixels are injected with a charge, while the odd pixels are not injected with a charge (dark current level).

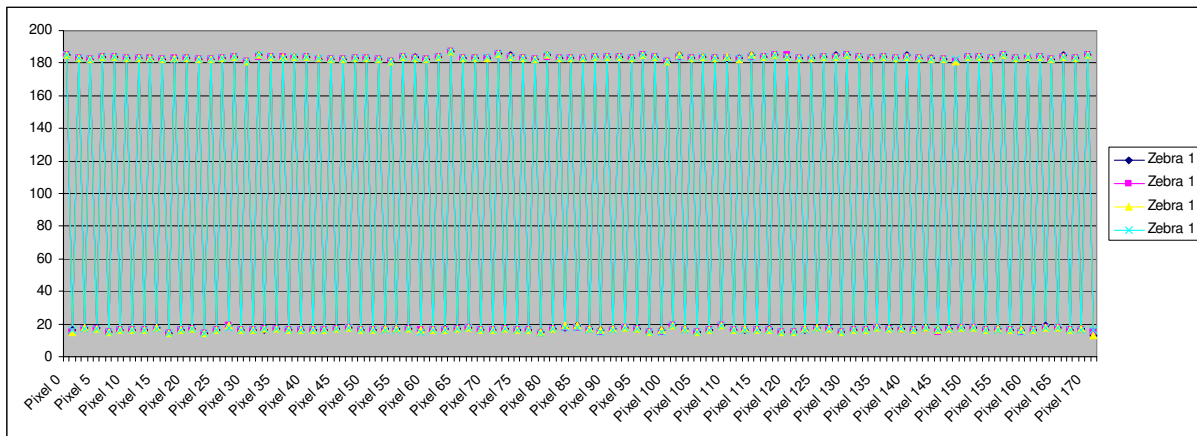

Fig. 1. Five runs of a Zebra pattern test on a 172 pixel linear optical array

This test mode allows easy and fast sensor integrity testing at probing, final test. Best of all this allows integrity checking during operation in the application.

3.3 Adding Temperature Sensors on Chip

The output voltage of an internal temperature sensor is converted by an ADC. The converted value is included in the read-out data. This information allows continuous monitoring of die temperature.

3.4 Digital Output Communication Redundancy

Optical sensors that feature a digital output like SPI can benefit from proven digital communication redundancy schemes. One example is adding additional bits to the useful data and adopting a cyclic redundancy code (CRC) to check for errors in the communication stream and to correct these errors where possible.

For example when using a 16-bit CRC, the generation of the CRC is based on the international standard CCITT 16-bit CRC polynomial:

$$x^{16} + x^{12} + x^5 + x^0$$

The probability of detecting errors by using this polynomial is given in the table below.

Type of error	Probability of error detection
One bit errors	100%
Two bit errors	100%
Any odd number of bits in error	100%
Burst errors up to 16 bit	100%
Any random error	99.9985%

Table 1: 16-bit CRC Error Checking Accuracy

3.5 Design Failure Mode and Effect Analysis (DFMEA)

The goal of DFMEA is to identify every potential single point of failure in a chip, to assess the impact on chip operation and to make sure all failures are detected at probing and final test as well as at operation in the application. As a conclusion, DFMEA analysis is standard procedure in automotive systems design and it is applied rigorously for safety critical applications.

An example of a DFMEA analysis on a sample and hold circuit (that connects to a photodiode) is given below:

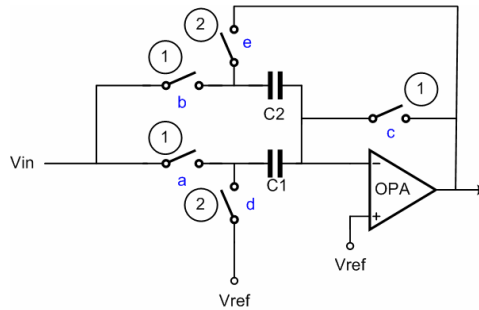

Fig. 2. Equivalent circuit of a Sample and Hold function for DFMEA analysis

This is the DFMEA equivalent of a schematic where real transistors have been replaced by their switch equivalents. The failure mode of every individual switch is being stuck to “open” or being stuck to “close”. By iterating through all possible single failure modes, we are assured that all fault events are detectable.

A FMEA analysis can be performed at the level of the circuit schematics, but it can also be performed at the level of a process. Below we give a FMEA example for a probing process:

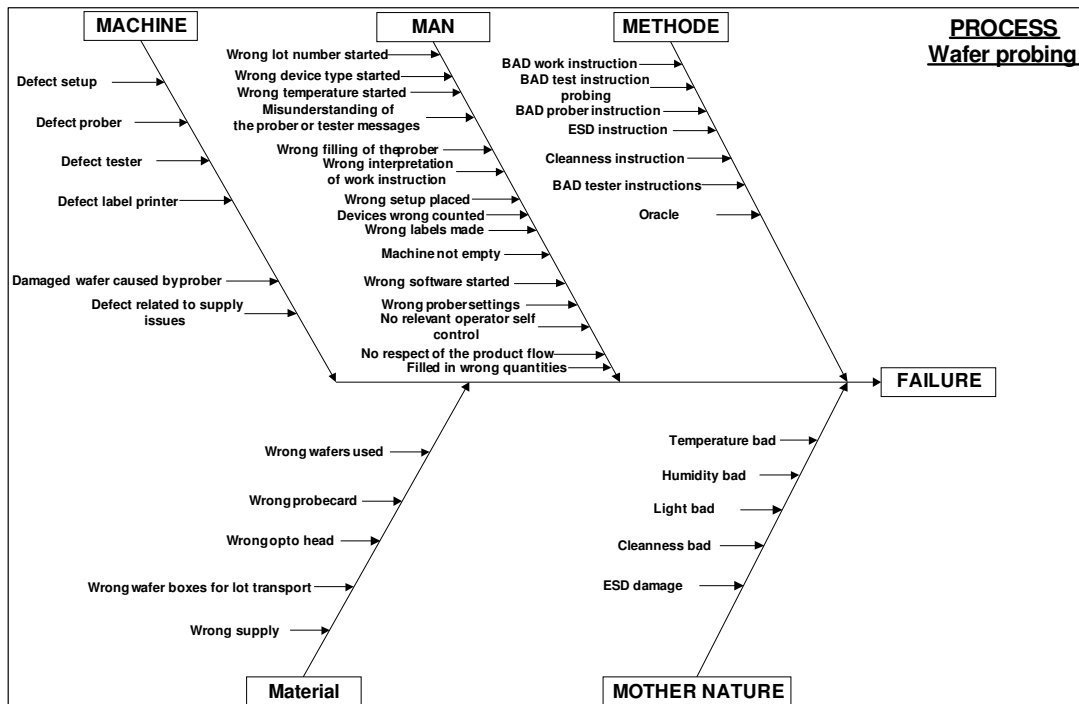

Fig. 3. FMEA analysis of a wafer probing process

3.6 Robustness at the Application Level

Automotive printed circuit boards should not use high resistance values, like 1 Mohm. This is because moisture and dirt that can form an alternative resistive path in parallel with the high value resistor. This rule of thumb implies that a typical photo sensor design, built by combining a discrete photodiode or phototransistor with a high transimpedance resistor to amplify the photocurrent, will not meet the robustness requirement.

Thus the preferred choice for automotive applications is an integrated photo sensor that features the photodiode and amplifier in one package and best, on one chip.

A second example is the optical switch function. Traditional optical sensors will slow down when oversaturated by light. This is because the abundant amount of photons will free an ocean of electrons that will need to get evacuated from the photodiode well. A smart design technique is to allow large amounts of photons in an optical sensor and to optimize electron evacuation to keep high speed light response when the sensor is oversaturated with light.

4. IMPACT OF “HIGH PERFORMANCE” REQUIREMENT ON SENSOR DESIGN

The automotive environment imposes following generic specifications for optical sensors:

- Wide temperature range
- Easy calibration and compensation by the sensor module manufacturer – “zapping”

- High dynamic range for ambient light applications
- High sunlight rejection for LED light based applications

4.1 Wide Temperature Range

Typically the automotive operating temperature range is -40degC..+125degC. Especially the +125degC corner is a design challenge to meet the optical sensors responsivity spec given the natural responsivity change of silicon with temperature.

Automotive so called “under the hood” applications go even higher than +125degC. Here optical sensors are typically not used due to the very harsh and polluting environment.

4.2 Easy calibration and compensation by the sensor module manufacturer – “zapping”

Calibration or sensitivity tuning at module level is an obstacle for most automotive companies, given the high costs and needed expertise. This implies that optical sensors will have to be tuned/calibrated by the sensor manufacturer.

One way of tuning by the sensor manufacturer is zapping. As an example, the figure shows measurement data of the average optical responsiveness of an optical linear array. The different colors indicate consecutive wafer production lots. After zapping, the responsiveness is brought within tight specification limits, independent of the production lot.

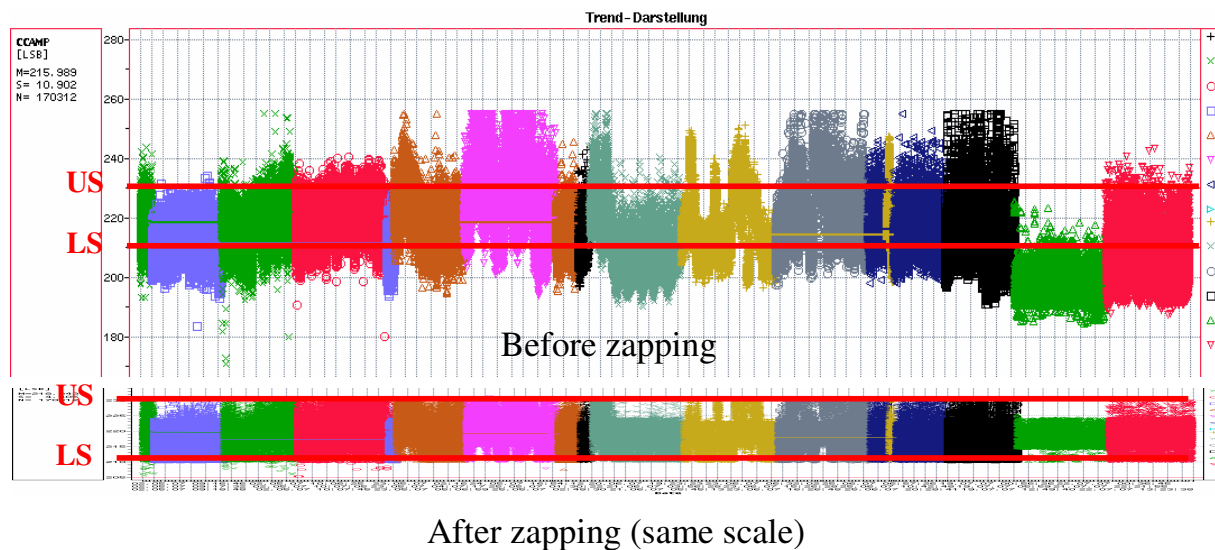

Fig. 4. Average Optical Responsiveness of Linear Optical Arrays. Every color shows a different production lot. Measurements are given before zapping (top) and after zapping (bottom)

A second way of tuning by the sensor manufacturer is by saving calibration data in embedded EEPROM so that the module manufacturer can read out this data to identify system parameters at the module level.

4.3 High Dynamic Range

The light intensity range of applications that measure ambient light, like camera’s and sunload sensors, is between 1 lux and 100k lux. This implies that the dynamic range for these sensors should

span 120dB. The dynamic range of a scene is usually higher than the dynamic range of the sensor that is used to acquire the image. The dynamic range of a sensor is limited by fabrication technology. Design optimizations must be found that increase the intra-scene dynamic range a sensor can achieve. Design strategies to optimize dynamic range include:

- Logarithmic response
- Dual pixel
- Multiple slopes method based on pixel reset, pixel clamping, intermediate charge transfer or intermediate flushing
- Multiple slopes method based on well sizing

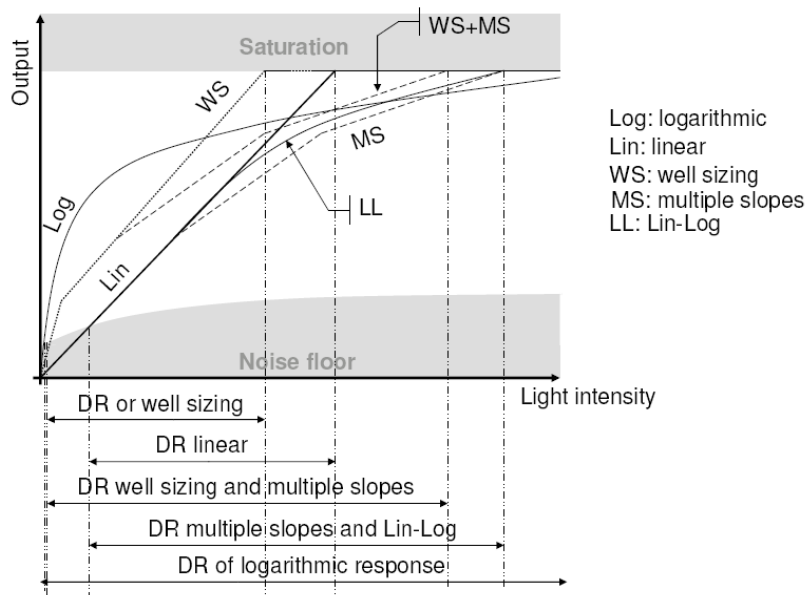

Fig. 5. Comparing Options for High Dynamical Range Applications

This topic is described in detail in [1],[2].

4.4 High sunlight reject

Applications based on rain/light sensors and time-of-flight optical cameras typically use a source of near infrared light around 900nm wavelength. This wavelength is strongly present in sunlight as well, so sunlight rejection strategies in design are key.

5. IMPACT OF AUTOMOTIVE REQUIREMENTS ON PACKAGING

Package choice is crucial for automotive sensors. The automotive environment is a harsh environment including mechanical stress, temperature cycles, pollutants and moisture.

5.1 AEC-Q100 Stress Test Qualification

The AEC-Q100 standard is the automotive standard for stress test qualification. This standard defines many rigorous device qualification activities to validate IC design, fabrication process and packaging. Some examples of these are:

- Preconditioning to simulate solder reflow 260degC (3 times) at MSL3 conditions
- 1000 Temperature Cycles -50degC .. +150degC
- Temperature and Humidity Bias: 1000 operating hours at 85degC and 85% relative humidity
- Autoclave: 96h at 121degC and 100% humidity
- High Temp. Storage Life: 1000 hours at 150degC
- Electrostatic Discharge capability

5.2 Ceramic Packages

In terms of quality, ceramic packages are a good choice. Unfortunately, they are also on the expensive side for automotive use.

5.3 Clear Compound Packages

Clear compound packages, the preferred choice of many non-automotive manufacturers, show problems concerning optical performance of the compound at higher temperatures over life-time. Furthermore, solder reflow at 260degC is often not possible. Also the temperature coefficient does not match exactly with silicon; so that temperature induced stress may occur.

5.4 Standard “Green” Compound Open-Cavity Packages

Using standard “green” epoxy mold compound yields all the benefits of standard electronics packaging, including compatibility with solder reflow at 260degC, matching of temperature coefficient with silicon and high-volume pricing. The active optical path should, of course, not be over molded (open cavity) but the bond wires and all other sensor electronics do.

Depending on the application, a glass cover may or may not be needed. Clear advantages of a glass cover are the higher resistance against dirt and the higher immunity against damage due to mechanical contacts. In our experience, main drawbacks are lower optical path performance (sensitivity loss, reflection, refraction), possible glass fogging and extra cost and/or yield impact.

The graph below shows the open cavity package volumes for automotive packages for our company. As a conclusion the open cavity SOIC and open cavity DFN packages are the preferred package choice in automotive.

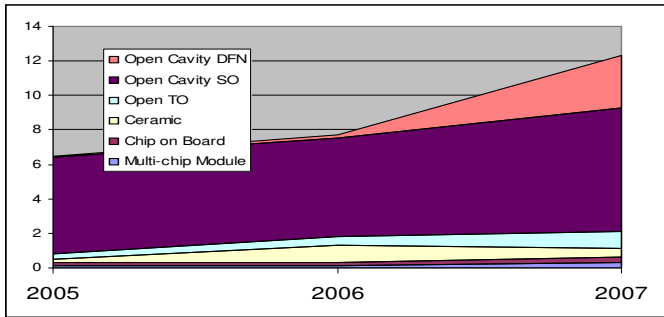

Fig. 6. Evolution of Melexis' Automotive Open-Cavity Package Volumes

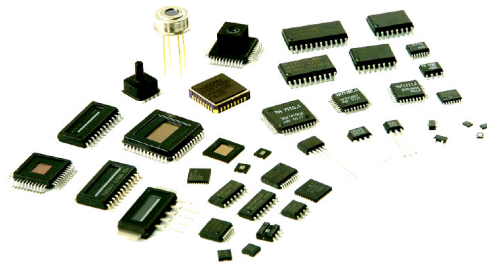

Fig. 7. Selection of Melexis' Open-Cavity and Closed-Cavity Packages

6. AUTOMOTIVE APPLICATIONS BASED ON OPTICAL SENSORS

The figure below gives an overview of current main optical sensor applications in cars. The red and asterisk marked items are safety critical application. The blue marked items are considered comfort applications.

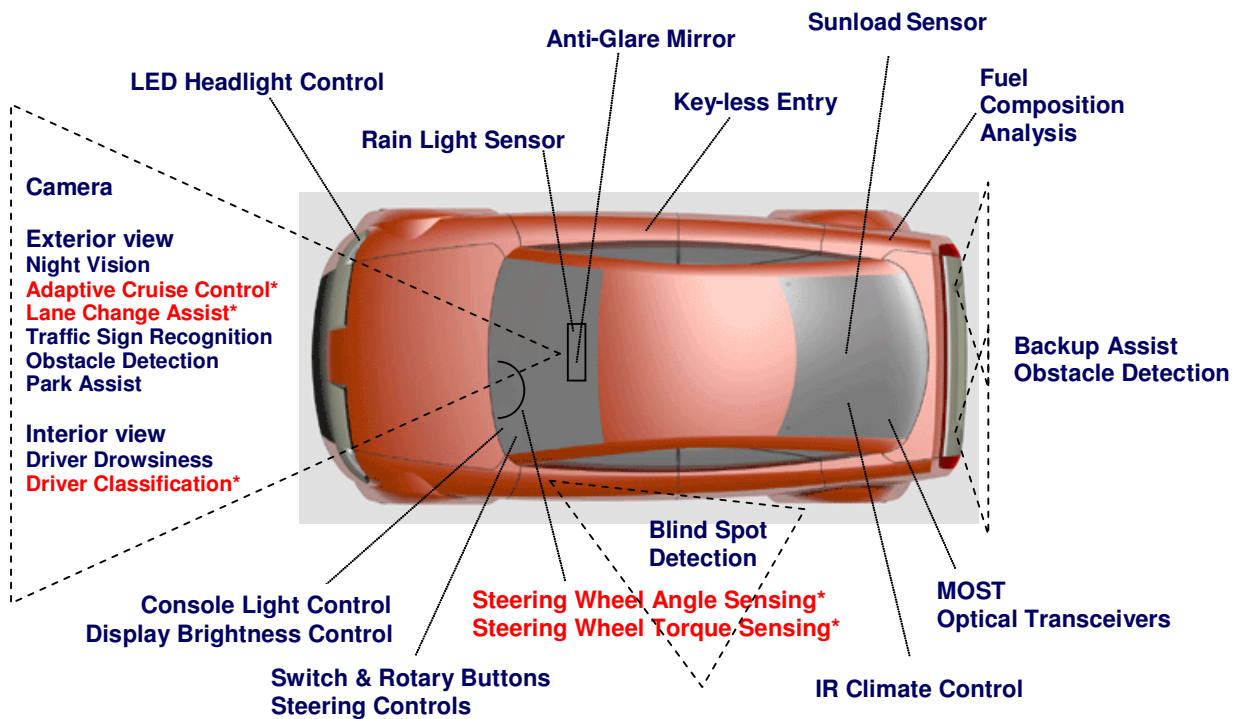

Fig. 8. Automotive Applications based on Optical Sensors

A detailed examination of steering wheel angle measurement reveals that until recently this was considered a non-safety critical application. The steering angle is one of the inputs of the automotive Electronic Stability Control or Platform (ESC or ESP) system.

The newer Electric Power Assist Steering (EPAS) and Drive-by-Wire systems may feature optical sensors for steering angle measurement. Both are certainly safety critical applications: failure of the angle sensing module can result in difficult to control car steering.

The figure below shows a rendering of the optical steering angle measurement principle.

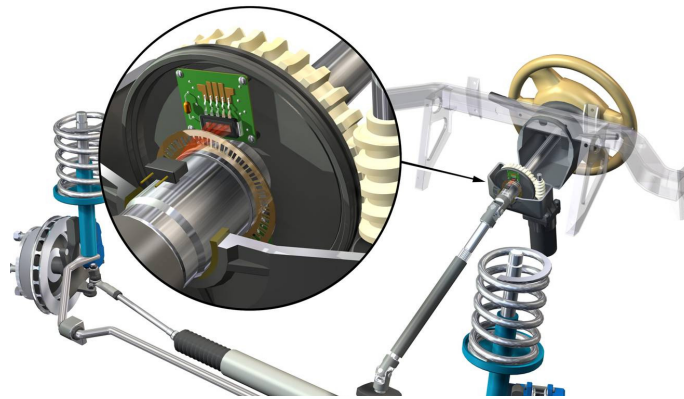

Fig. 9. Steering Angle Measurement with a Linear Optical Array

A visible or NIR LED source shines uniform light on a linear optical array through a code disk. This can be a one-track punched metal disk (see figure) or a multi-track plastic Grey code disk with printed patterns. The light pattern that falls on the sensor is then interpreted by a microcontroller to give the exact steering angle.

Also camera-based applications like Adaptive Cruise Control, Lane Departure Warning and Driver Classification are safety critical.

7. ABOUT MELEXIS, INC.

Melexis [3] is active in the development of integrated optical sensors with over eight years experience and has over 15 years experience developing automotive smart sensors and smart actuators in multiple technologies. Our optical sensor portfolio includes automotive optical switches, single pixel light sensors like light-to-voltage and light-to-frequency converters, optical linear arrays and camera imager sensors. Projects are ongoing for automotive time-of-flight sensors, rain-light sensors, ambient light sensors and color sensors.

REFERENCES

¹ A. Darmont, *Methods to extend the dynamic range of snapshot active pixels sensors*, Photonics West 2008, Proceedings of SPIE

- ² S. Maddalena, A. Darmon, R. Diels, *Automotive CMOS imagers sensors: from consumer to automotive*, AMAA2005, Advanced Microsystems for Automotive Applications 2005
- ³ <http://www.melexis.com>