

Interlink Electronics FSR® Force Sensing Resistors®

FSR® Integration Guide

*Document part number EIG-10000 Rev. B
Interlink Electronics and the six dot logo are registered trademarks of Interlink Electronics,*

Table of Contents

1.0	Introduction	1
2.0	Theory of Operation.....	2
3.0	FSR® Force Sensing Resistor® Products.....	5
4.0	Performance Specifications	15
5.0	Environmental and Reliability Data.....	17
6.0	Measurement Techniques	18
7.0	Performance Optimization	25
8.0	FAQ	27
9.0	FSR Usage: The Do's and Don'ts	30
10.0	Glossary.....	31
11.0	Intellectual Property & Other Legal Matters	32
12.0	Contact Interlink Electronics.....	33

1.0 Introduction

1.1 Our Background

Launched in 1985, Interlink Electronics is the world's leading innovator of cost effective polymeric force sensors. Our R&D team has developed a spectrum of technologies for "touch" and user interfaces solutions, and machine process controls. Today, with over 20 years of industry-leading experience, Interlink Electronics continues to innovate by designing and manufacturing sensors for a full range of applications such as industrial, military, consumer electronics, mobile, medical, and pointing devices.

One of the first uses of our patented thin film Force Sensing Resistor® (FSR) technology was in electronic drums and other musical instruments. Mobile phones, portable media players, navigation devices, handheld gaming, digital cameras, and other portable electronics are just a handful of devices that use our FSR technology. Customers that have used our sensor solutions include: Motorola, Samsung, Sony, LG, Varian, and Microsoft.

Serving a global customer base from offices in the U.S., and Japan, Interlink Electronics continues to expand with a proven track record of breakthrough technology and customer service. With a rich and diverse product history, we have established ourselves as a clear business and technology leader in a wide range of markets and are currently reshaping how organizations connect with their customers.

2.0 Theory of Operation

The most basic FSR consists of two membranes separated by a thin air gap. The air gap is maintained by a spacer around the edges and by the rigidity of the two membranes. One of the membranes has two sets of interdigitated fingers that are electrically distinct, with each set connecting to one trace on a tail. The other membrane is coated with FSR ink. When pressed, the FSR ink shorts the two traces together with a resistance that depends on applied force.

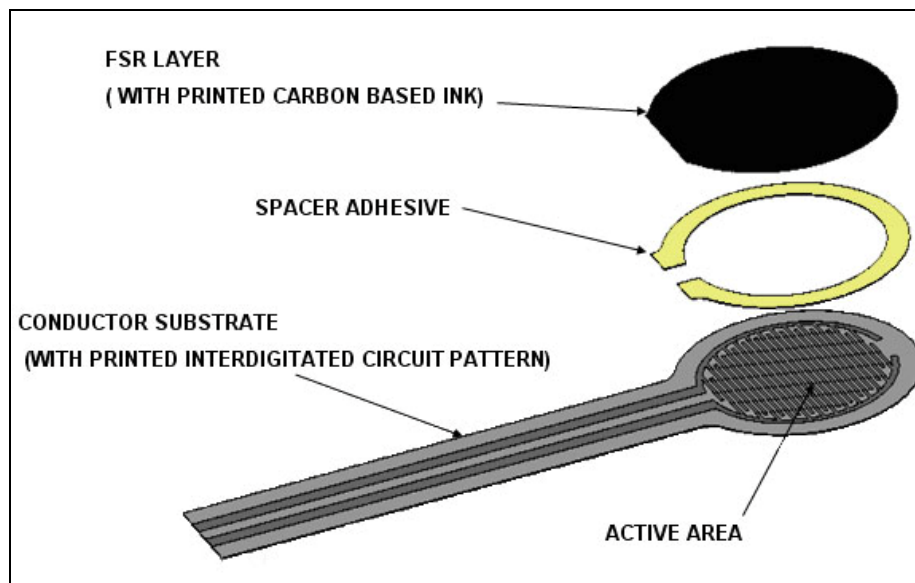

Figure 1: Basic FSR Construction

2.1 Basic Construction

Around the perimeter of the sensor is a spacer adhesive that serves both to separate the two substrates and hold the sensor together. This spacer typically has a thickness between 0.03mm and 0.15mm. This spacer may be screen printed of a pressure sensitive adhesive, may be cut from a film pressure sensitive adhesive, or may be built up using any combination of materials that can both separate and adhere to the two substrates.

Both membranes are typically formed on flexible polymer sheets such as PET, polyimide, or any other film material. In custom force sensors, the top substrate could be made with a slightly less flexible material, such as polycarbonate, thin metal or very thin circuit board material, as long as it is sufficiently deformable to allow a reasonable force to push the top substrate against the bottom substrate to activate the sensor.

The inside surface of one substrate is coated with FSR® carbon-based ink. When the two substrates are pressed together the FSR ink surface shorts across the interdigitated fingers of the facing surface. The result is that the resistance between the conducting fingers is inversely proportional to the applied force.



The conductive traces are typically screen printed from silver polymer thick film ink. However, these traces may also be formed out of gold plated copper as on flexible or standard circuit boards (FPC or PCB).

Force may be applied to either substrate. One of the exterior surfaces typically includes a mounting adhesive layer to allow mounting to a clean, smooth, rigid surface.

2.2 Force Curve

A typical resistance vs. force curve is shown in Figure 2. For interpretational convenience, the data is plotted on logarithmic scales. This particular force-resistance curve was measured from a model 402 sensor (12.7 mm diameter circular active area). A silicone rubber actuator with a 4 mm spherical radius tip and 60 Shore A durometer was used to press on the FSR).

The “actuation force” or turn-on threshold is typically defined as the force required to bring the sensor from open circuit to below 100k Ω resistance. This force is influenced by the substrate and overlay thickness and flexibility, size and shape of the actuator, and spacer-adhesive thickness (the size of the internal air gap between membranes).

Figure 2: Resistance vs. Force

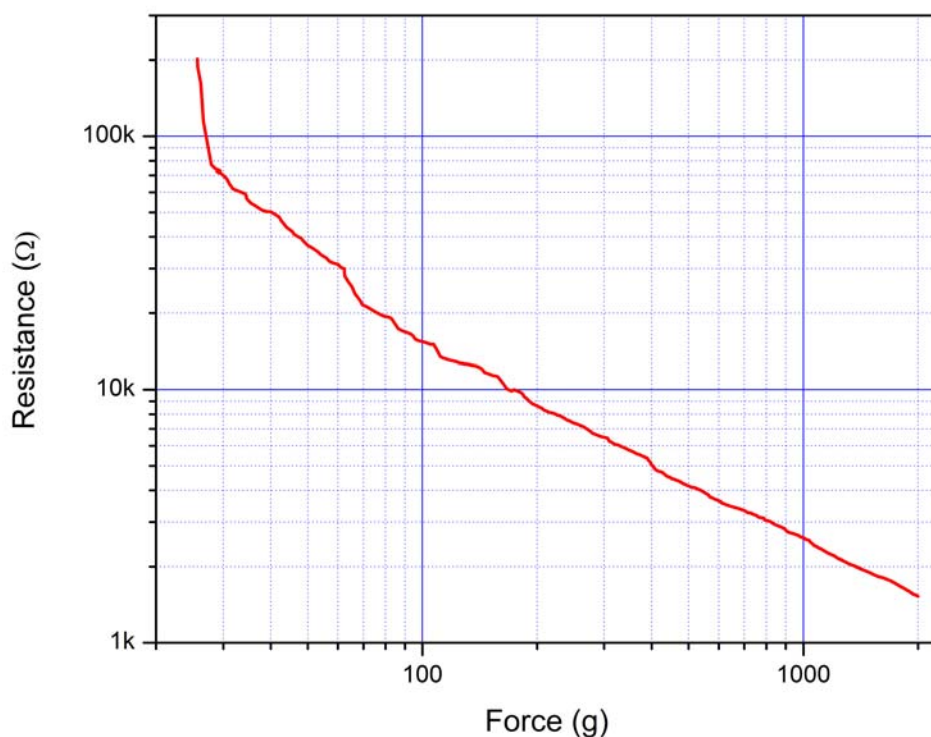

Immediately after turn-on, the resistance decreases very rapidly. At slightly higher and then intermediate forces, the resistance follows an inverse power law. At the high forces the response eventually saturates to a point where increases in force yield little or no decrease in resistance. Saturation can be pushed higher by spreading the applied force over a larger actuator.

3.0 FSR® Force Sensing Resistor® Products

Interlink designs and manufactures a broad array of sensor types. The basic FSR described in Figure 1 may be made in almost any shape or size and can even be made to detect position in addition to force. All of these products may be combined into sensor arrays.

Single Zone FSR 400 Series

Single zone sensors can be made in a variety of shapes and sizes. Interlink provides both custom sensors and a standard catalog of round, square, and strip shaped single zone parts. A Hardware Development Kit is available.



4-Zone Array

4-Zone sensors measure force applied in each of four cardinal directions. These are typically placed under buttons in keyboards or remote controls in order to create a pointing mouse. By measuring force on each zone, smooth 360° control can be accomplished. Interlink provides both custom sensors and a standard catalog of round and square shaped 4-zone arrays. A Hardware Development Kit is available.

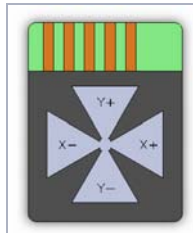

Other Custom Arrays

In addition to 4-zone arrays, any other combination of force sensors can be arrayed on a common substrate of any shape. One example use is under the keys of a cell phone to measure force and more naturally fire haptic feedback. Another use is in the medical field, under mattresses or mats in order to measure patient presence, position, or motion.

Custom Pressure Sensitive Snap Dome

In applications requiring tactile feedback, such as buttons in consumer electronics, the usual method is to use a metallic snap dome. Adding force measurement with an FSR can enhance this basic switch function. The dome and FSR are built together into one sensor. Force can be measured both pre- and post-snap. This enables analog control functions such as zoom, scroll, volume, etc. In addition, these pressure sensitive domes can be put into arrays. In the example pictured below, the FSR snap dome array replaces the 4-way thumb navigation area of a smart phone to add 4-way directional control, circular scrolling, and pressure sensing functionality.

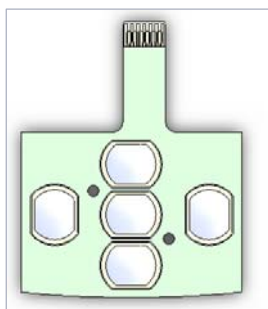

Force Sensing Linear Pots

The manufacturing technology of FSRs also lends itself to the creation of various position sensors. Interlink has expertise in building, designing, and manufacturing several types, including: linear strips, arcs, full rings, and resistive touchpads. All of these position sensors may also be used to measure applied force.

Linear potentiometer strips are three wire devices that can measure position and pressure of touch. These are useful in man and machine interfaces, such as slider controls. They are also useful in machine control, for example to measure the position of a plunger in a vial or tank or some position in a motion control system. These sensors can be custom made between 4mm and 450mm wide and as long as 550mm. More information regarding linear pots can be found in Force Sensing Linear Potentiometer (FSLP) Integration Guide. A Hardware Development Kit is also available for the FSLP.

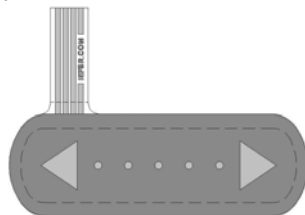

FSLP
Standard



FSLP 10cm

3.1 Standard

Standard FSRs deliver the most cost competitive solutions for a wide variety of applications. Cost savings are primarily achieved through reductions in tooling and engineering labor costs. The Interlink catalog of standard single zone FSRs is comprised of round, square, and strip sized sensors.







PART TYPE	DESCRIPTION	PART IMAGE
Model 400	FSR, 0.2" [5.08mm] Circle	
Model 400 Short Tail	FSR, 0.2" [5.08mm] Circle	
Model 402	FSR, 0.5" [12.7mm] Circle	
Model 402 Short Tail	FSR, 0.5" [12.7mm] Circle	
Model 406	FSR, 1.5" [38.1mm] Square	
Model 408	FSR, 24" [609.6mm] Strip	

Figure 3: Different types of standard FSR's

Standard round FSRs are offered in both Model 400 (Figures 4 & 5) and Model 402 (Figures 6 & 7) standard models. They are common and versatile products that can be incorporated into a variety of devices.

Model 400 Round

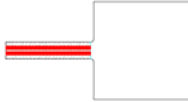
Measurements: millimeters

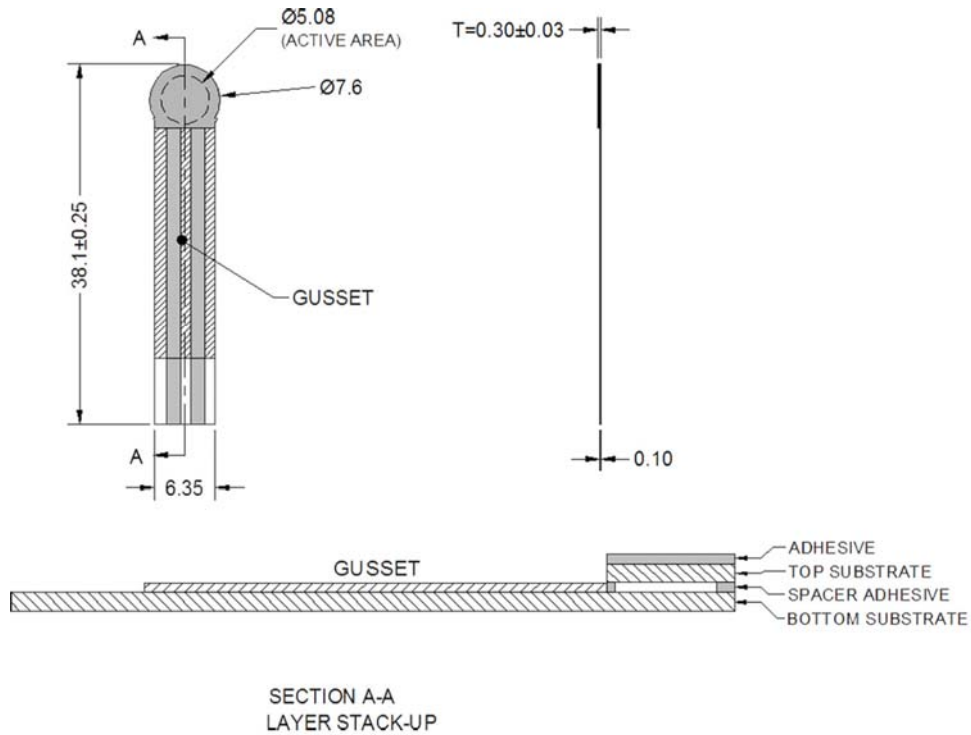

Exploded View

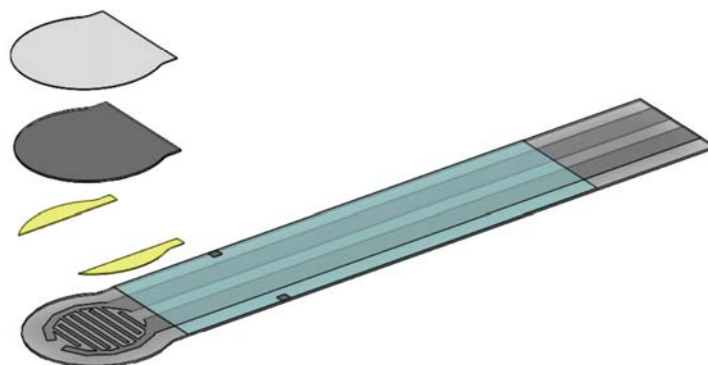
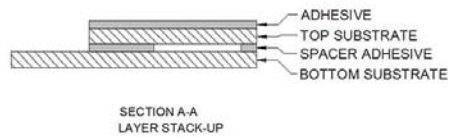
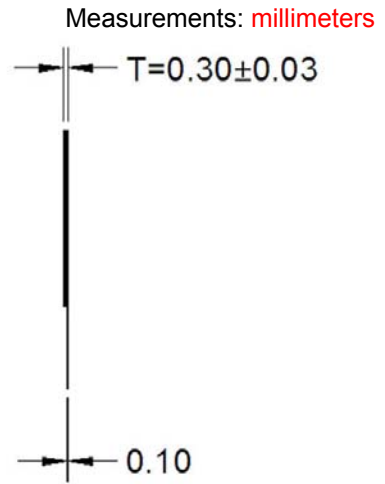
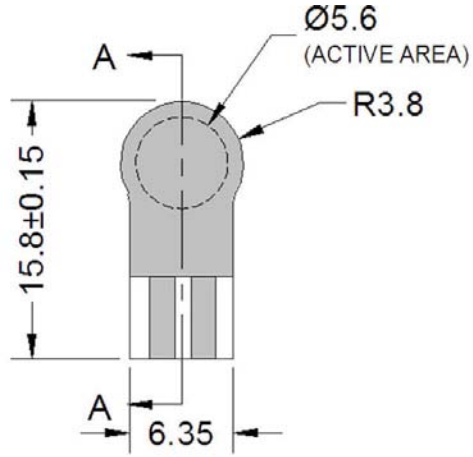

Figure 4: Model 400 Round FSR

Model 400 Round Short Tail



Exploded View

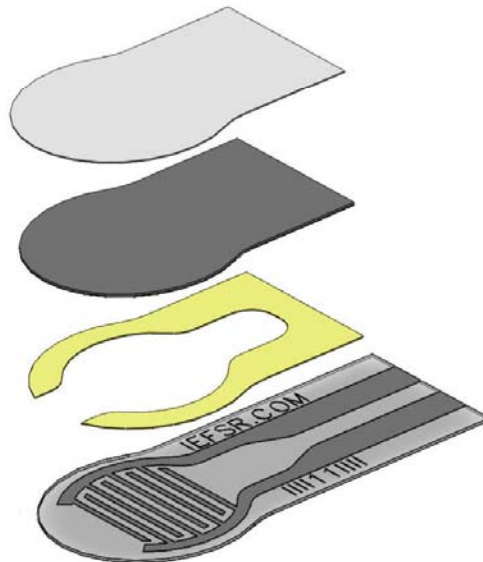
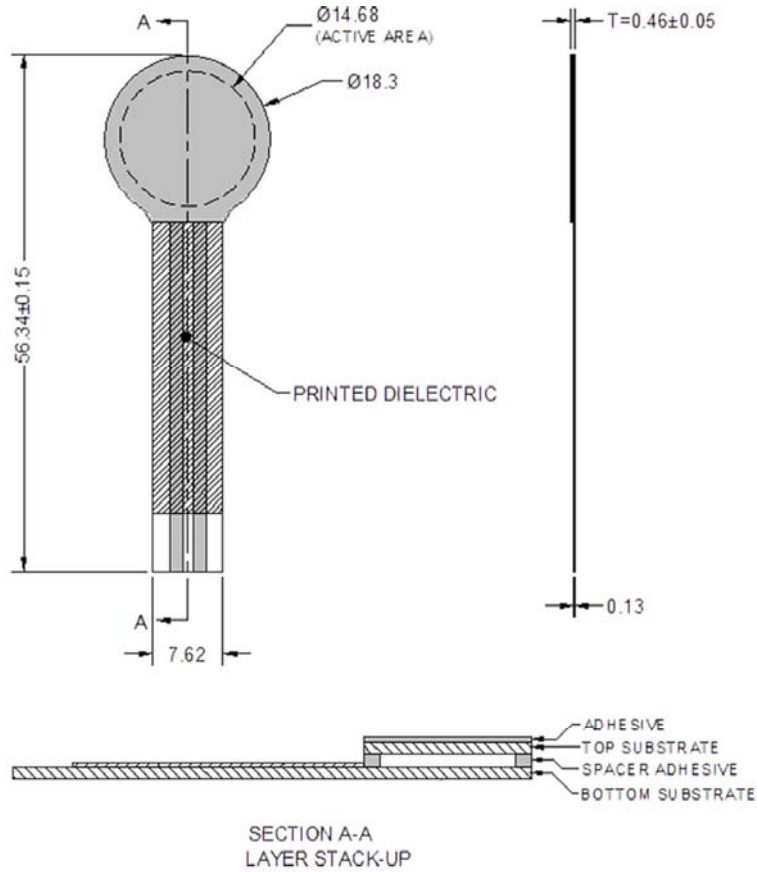

Figure 5: Model 400 Short Tail Round FSR

Model 402 Round

Measurements: millimeters



Exploded View

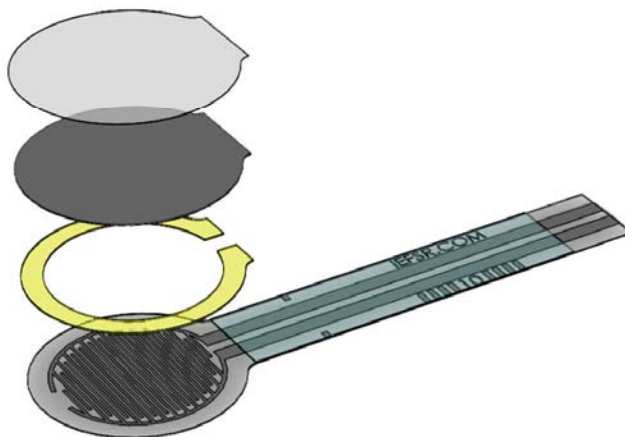
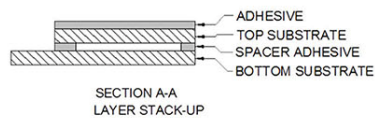
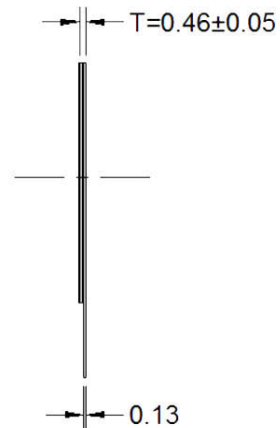
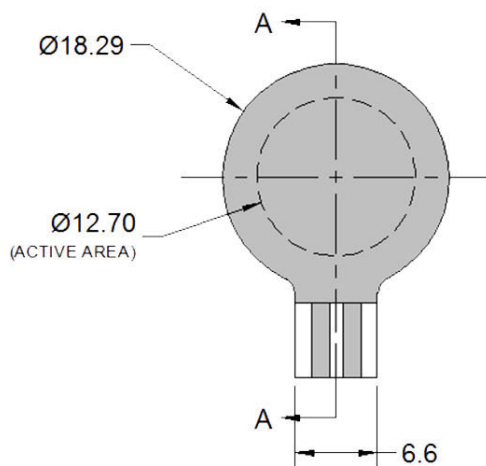

Figure 6: Model 402 Short Tail Round FSR

Model 402 Round Short Tail

Measurements: millimeters



Exploded View

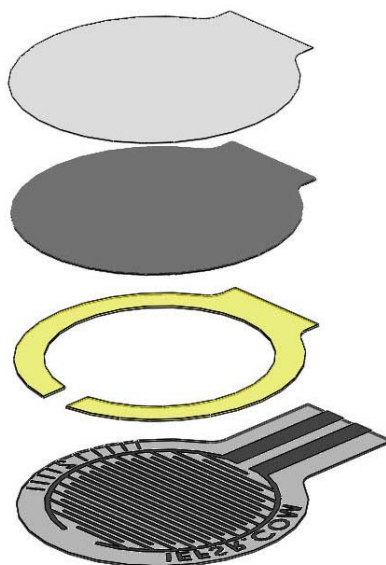
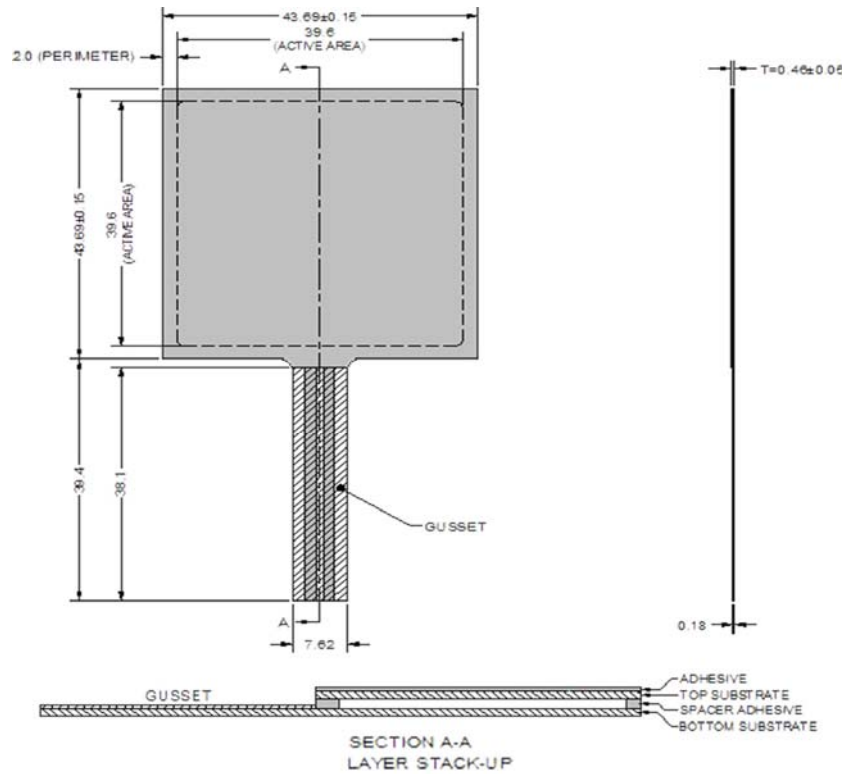

Figure 7: Model 402 Short Tail Round FSR

The standard Model 406 (Figure 8) square FSR, as compared to the round FSR, offers similar functionality within a larger electrically active area.

Model 406 Square

Measurements: millimeters



Exploded View

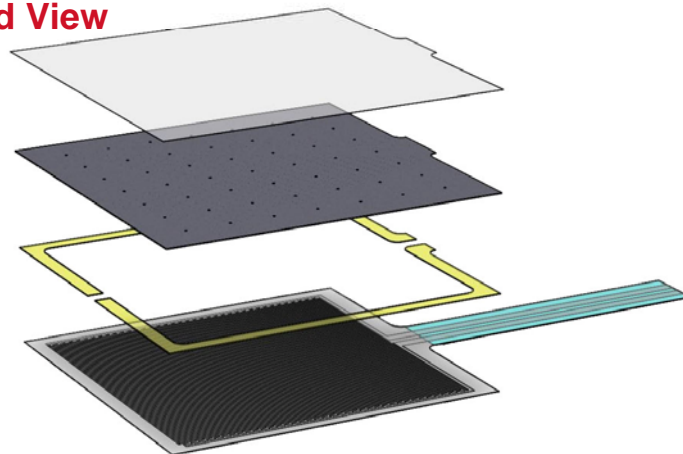
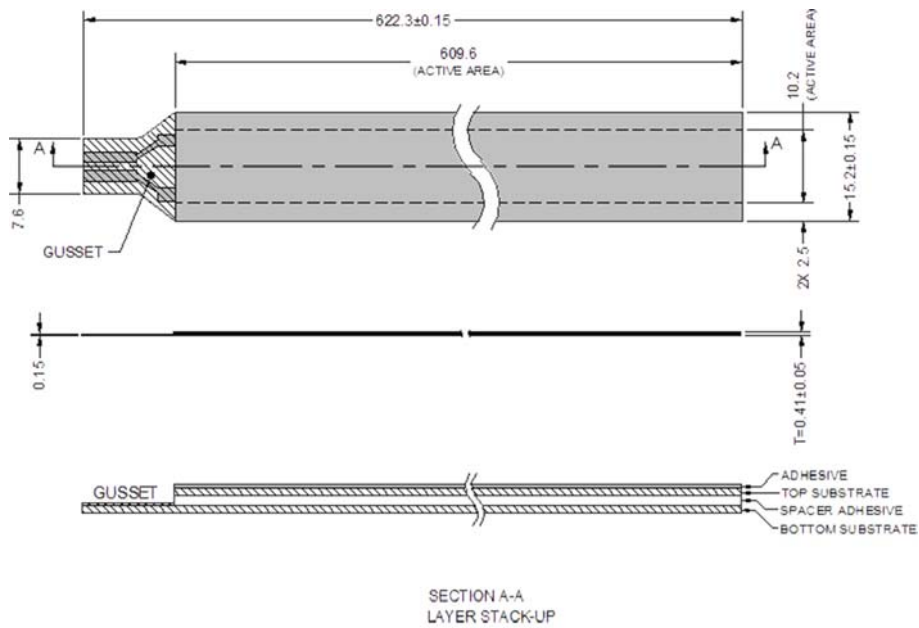

Figure 8: Model 406 Square FSR

The standard Model 408 (Figure 9) strip FSR is useful for force detection in large devices.

Model 408 Strip

Measurements: millimeters



Exploded View

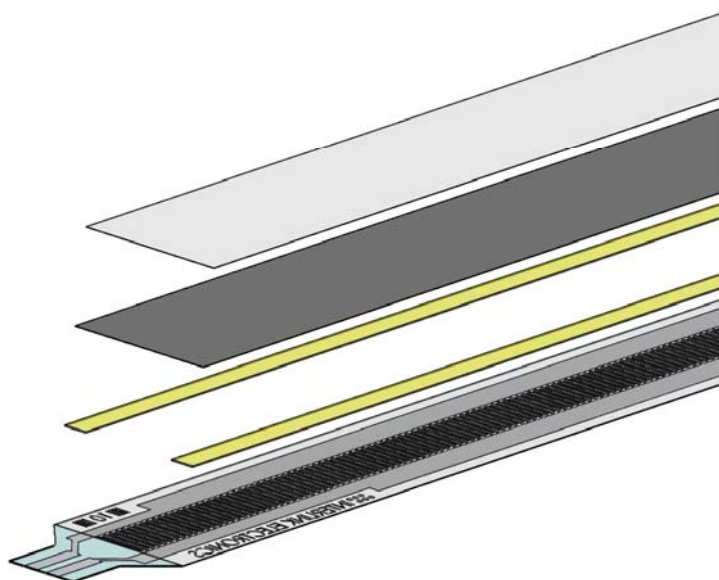

Figure 9: Model 408 Strip FSR

3.2 Custom Sensors

Custom sensors offer flexibility in meeting the needs of unique customer design requirements. All strip, ring, pad, pot, array, and 4 zone sensors are applicable.

Below are some of the typical customization options available. Contact your Interlink representative for additional details, custom sensor examples, and to learn more about the Custom Design Process.

Shapes and Sizes

Interlink custom sensors come in a variety of shapes, sizes, and zone quantities.

Graphic Overlays and Actuators

Incorporation of a protective graphic overlay is a design option to be considered for enhanced aesthetic and durability requirements. A decorative graphic can be screen printed on the inner surface of the overlay.

Material Options

While Interlink is capable of incorporating a broad range of materials, our sensors generally rely on the following core materials – PET, FPC, FR-4, various textured polyester films and adhesives.

Connection Methods

A wide range of connection options are available from flex tail and board to board connectors to direct solder & over mold and even conductive adhesives.

4.0 Performance Specifications

Below are typical parameters. The FSR is a custom device and can be made for use outside these characteristics. Consult us for your specific requirements.

General		
PARAMETER	VALUE	NOTES
Force Sensitivity Range	~0.2 to 20N	Dependent on mechanics
Break Force (Activation Force)	~0.2N min	Dependent on mechanics and FSR build
Part-to-Part Force Repeatability	± 6% of established nominal	With a repeatable actuation system, single lot.
Single Part Force Repeatability	± 2% of initial reading	With a repeatable actuation system
Hysteresis	+ 10% Average	$(R_{F+} - R_{F-})/R_{F+}$
Long Term Drift	< 5% per $\log_{10}(\text{time})$	Tested to 35 days, 1kg load
Force Resolution	Continuous	Depends on measurement electronics
Stand-Off Resistance	> 10M Ω	Unloaded, unbent
Switch Travel	0.05mm	Typical; depends on design
Device Rise Time	<3 microseconds	Measured with drop of steel ball
Maximum Current	1 mA/cm ² of applied force	
EMI / ESD	Generates no EMI; not ESD sensitive	

Specifications are derived from measurements taken at 1000 grams, and are given as (one standard deviation / mean), unless otherwise noted.

Environmental Performance Specifications

PARAMETER	TYPICAL R CHANGE	NOTES
Hot Operation	-15%	85°C after 1 hour
Cold Operation	-5%	-40°C after 1 hour soak
Hot Humid Operation	+10%	+85°C, 95% RH, after 1hour
Hot or Cold Storage	-10%	-25°C to +85°C, 120hrs
Hot Humid Storage Temperature	+ 30% of established nominal resistance	+85°C, 95% RH, 240 hours
Thermal Shock	± 2% typical	-25°C to +70°C, 10 Cycles, 15 minute dwell, 5 minute transitions

Note: Specifications are derived from measurements taken at 1000 grams.

Durability Performance Specifications

PARAMETER	TYPICAL R CHANGE	NOTES
Tap Testing	-10%	10 million actuations, 1kg, 4Hz
Constant Load	-5%	2.5 kg standing load, 24 hrs
Chemical Resistance		The following chemicals do not affect the operation when applied to the outside of the sensor: cola, coffee, isopropyl alcohol, soap solution, household cleaners. No others tested. Application is a single drop on the exterior of the sensor that is allowed to soak until evaporation and does not enter the sensor.
Sensitivity to Noise/Vibration	No effect	

Note: Specification derived from measurements taken at 1000 grams.

Linear Pots

PARAMETER	VALUE	NOTES
Positional Resolution	0.075 to 0.5 mm (0.003" to 0.02")	Dependent on actuator size and electronics and exact design
Positional Accuracy	Better than $\pm 2\%$ of full length	

5.0 Environmental and Reliability Data

Contact your Interlink Representative for full details.

6.0 Measurement Techniques

6.1 Circuit

Voltage Divider

Figure 10: FSR Voltage Divider

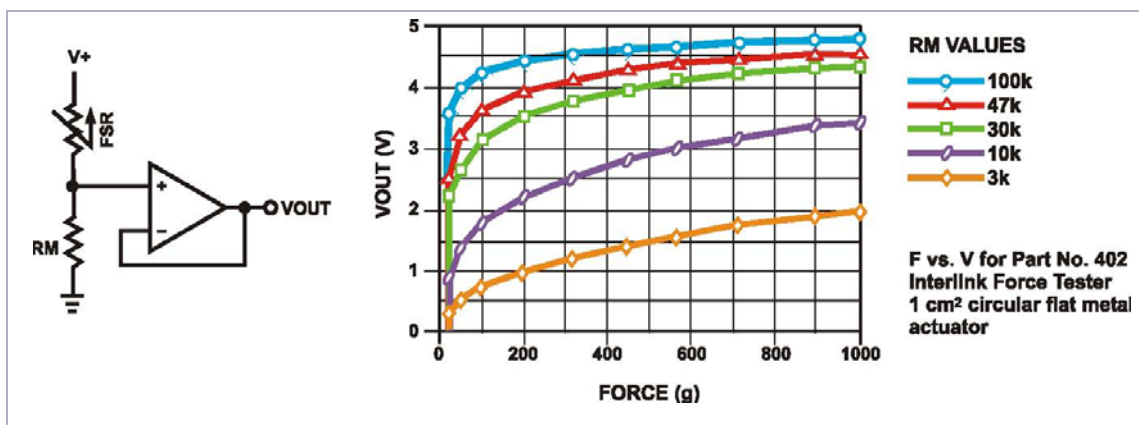

FSR Voltage Divider

For a simple force-to-voltage conversion, the FSR device is tied to a measuring resistor in a voltage divider (see figure below) and the output is described by the following equation:

$$V_{OUT} = \frac{R_M V_+}{(R_M + R_{FSR})}$$

In the shown configuration, the output voltage increases with increasing force. If R_{FSR} and R_M are swapped, the output swing will decrease with increasing force.

The measuring resistor, R_M , is chosen to maximize the desired force sensitivity range and to limit current. Depending on the impedance requirements of the measuring circuit, the voltage divider could be followed by an op-amp

A family of Force vs. V_{OUT} curves is shown on the graph above for a standard FSR in a voltage divider configuration with various R_M resistors. A (V_+) of +5V was used for these examples. Please note that the graph values are for reference only and will vary between different sensors and applications.

Multi-Channel FSR-to-Digital Interface

Figure 11: Multi-Channel FSR-to-Digital Interface

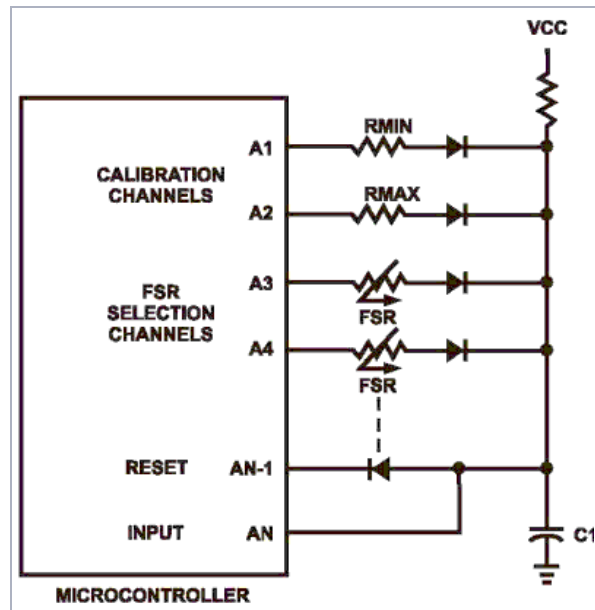

Sampling Cycle (any FSR channel):

The microcontroller switches to a specific FSR channel, toggling it high, while all other FSR channels are toggled low. The RESET channel is toggled high, a counter starts and the capacitor C1 charges, with its charging rate controlled by the resistance of the FSR ($t \sim RC$). When the capacitor reaches the high digital threshold of the INPUT channel, the counter shuts off, the RESET is toggled low, and the capacitor discharges.

The number of “counts” it takes from the toggling of the RESET high to the toggling of the INPUT high is proportional to the resistance of the FSR. The resistors RMIN and RMAX are used to set a minimum and maximum “counts” and therefore the range of the “counts.” They are also used periodically to re-calibrate the reference. A sampling cycle for RMIN is run; the number of “counts” is stored and used as a new zero. Similarly, a sampling cycle for RMAX is run and the value is stored as the maximum range (after subtracting the RMIN value). Successive FSR samplings are normalized to the new zero. The full range is “zoned” by dividing the normalized maximum “counts” by the number of desired zones. This will delineate the window size or width of each zone.

Continual sampling is done to record changes in FSR resistance due to changes in force. Each FSR is selected sequentially.

FSR Variable Force Threshold Switch

Figure 12: FSR Variable Force Threshold Switch

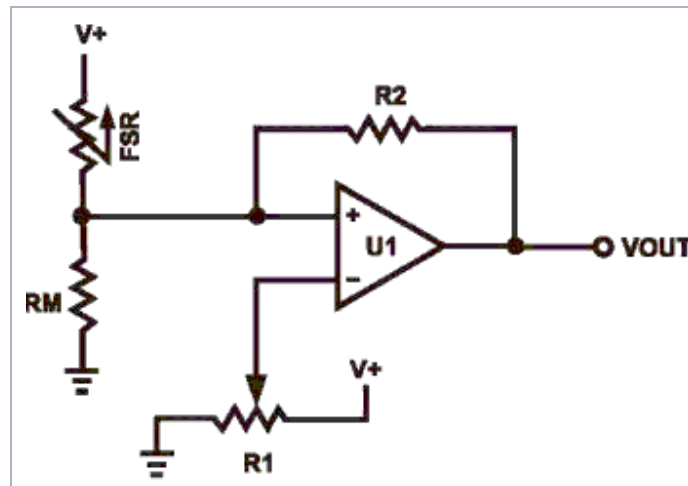

This simple circuit is ideal for applications that require on-off switching at a specified force, such as touch-sensitive membrane, cut-off, and limit switches. For a variation of this circuit that is designed to control relay switching, please see the next page.

The FSR device is arranged in a voltage divider with R_M . An op-amp, U1, is used as a comparator. The output of U1 is either high or low. The non-inverting input of the op-amp is driven by the output of the divider, which is a voltage that increases with force. At zero force, the output of the op-amp will be low. When the voltage at the non-inverting input of the op-amp exceeds the voltage of the inverting input, the output of the op-amp will toggle high. The triggering voltage, and therefore the force threshold, is set at the inverting input by the pot R1. The hysteresis, R2, acts as a “debouncer,” eliminating any multiple triggering of the output that might occur.

Suggested op-amps are LM358 and LM324. Comparators like LM393 also work quite well. The parallel combination of R2 with R_M is chosen to limit current and to maximize the desired force sensitivity range. A typical value for this combination is about 47k Ω .

The threshold adjustment pot, R1, can be replaced by two fixed value resistors in a voltage divider configuration.

FSR Variable Force Threshold Relay Switch

Figure 13: FSR Variable Force Threshold Relay Switch

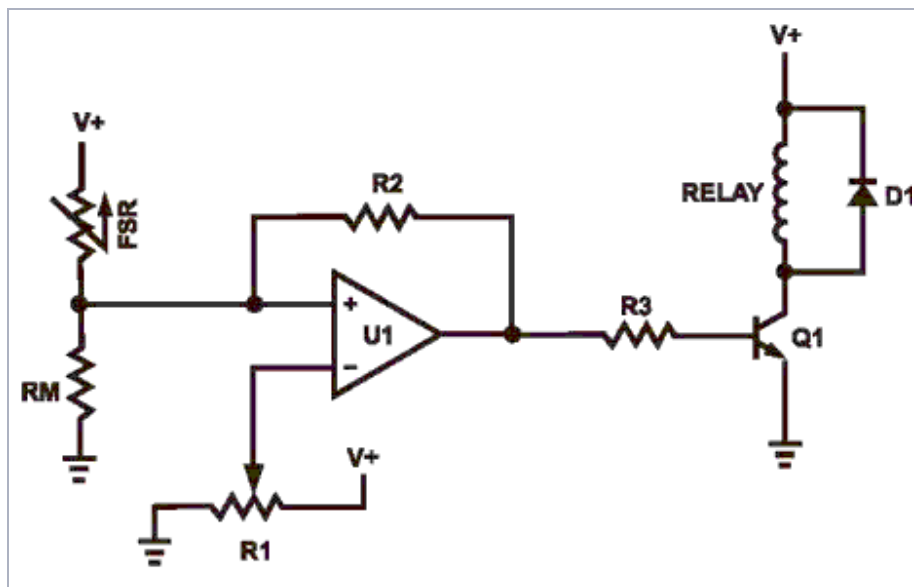

This circuit is a derivative of the simple FSR Variable Force Threshold Switch on the previous page. It has uses where the element to be switched requires higher current, like automotive and industrial control relays.

The FSR device is arranged in a voltage divider with R_M . An op-amp, U1, is used as a comparator. The output of U1 is either high or low. The non-inverting input of the op-amp sees the output of the divider, which is a voltage that increases with force. At zero force, the output of the op-amp will be low. When the voltage at the non-inverting input of the op-amp exceeds the voltage of the inverting input, the output of the op-amp will toggle high. The triggering voltage, and therefore the force threshold, is set at the inverting input by the pot R1. The transistor Q1 is chosen to match the required current specification for the relay. Any medium power NPN transistor should suffice. For example, an NTE272 can sink 2 amps, and an NTE291 can sink 4 amps. The resistor R3 limits the base current (a suggested value is 4.7k Ω). The hysteresis resistor, R2, acts as a “debouncer,” eliminating any multiple triggering of the output that might occur.

Suggested op-amps are LM358 and LM324. Comparators like LM393 and LM339 also work quite well, but must be used in conjunction with a pull-up resistor. The parallel combination of R2 with R_M is chosen to limit current and to maximize the desired force sensitivity range. A typical value for this combination is about 47k Ω .

Two fixed value resistors in a voltage divider configuration can replace the threshold adjustment pot, R1. The diode D1 is included to prevent fly back, which could harm the relay and the circuitry.

FSR Current-to-Voltage Converter

Figure 14: FSR Current-to-Voltage

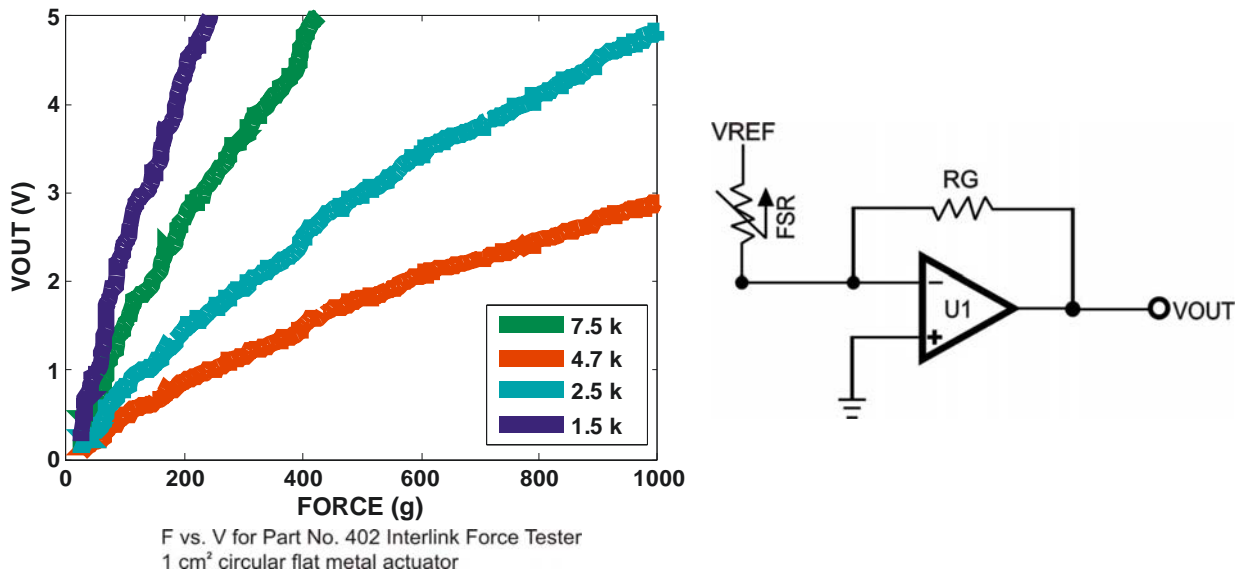

In this circuit, the FSR device is the input of a current-to-voltage converter. The output of this amplifier is described by the equation:

$$V_{OUT} = V_{REF} \cdot \left(-\frac{R_G}{R_{FSR}} \right)$$

With a positive reference voltage, the output of the op-amp must be able to swing below ground, from 0V to $-V_{REF}$, therefore dual sided supplies are necessary. A negative reference voltage will yield a positive output swing, from 0V to $+V_{REF}$.

$$V_{OUT} = \frac{(-R_G \cdot V_{REF})}{R_{FSR}}$$

V_{OUT} is inversely proportional to R_{FSR} . Changing R_G and/or V_{REF} changes the response slope. The following is an example of the sequence used for choosing the component values and output swing:

For a human-to-machine variable control device, like a joystick, the maximum force applied to the FSR is about 1kg. Testing of an example FSR shows that the corresponding R_{FSR} at 1kg is about 2.9k Ω . If V_{REF} is $-5V$, and an output swing of 0V to $+5V$ is desired, then R_G should be approximately equal to this minimum R_{FSR} . A full swing of 0V to $+5V$ is thus achieved. A set of FORCE vs. V_{OUT} curves is shown in Figure 15 for a standard FSR using this interface with a variety of R_G values.

The current through the FSR device should be limited to less than 1 mA/square cm of applied force. As with the voltage divider circuit, adding a resistor in parallel with R_{FSR} will give a definite rest voltage, which is essentially a zero-force intercept value. This can be useful when resolution at low forces is desired.

Additional FSR Current-to-Voltage Converters

These circuits are a slightly modified version of the current-to-voltage converter detailed on the previous page. Please refer to it for more detail.

Figure 15: Additional FSR Current-to-Voltage Converter

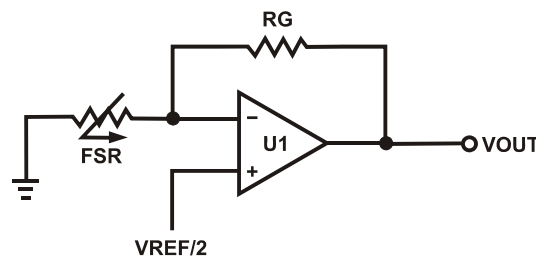

The output of Figure 15 is described by the equation:

$$V_{OUT} = R_M \left(\frac{V_{out} - V_+}{V_+} \right)$$

The output swing of this circuit is from (V_{REF}/2) to 0V. In the case where R_G is greater than R_{FSR}, the output will go into negative saturation. Suggested op-amps are LM358 and LM324.

Figure 16: Additional FSR Current-to-Voltage Converter

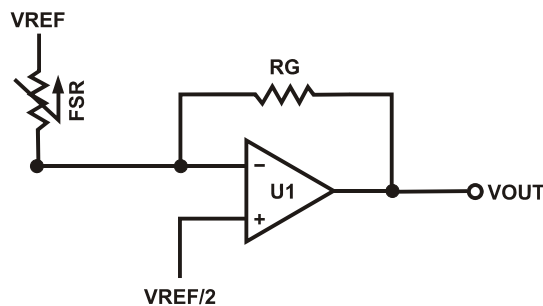

The output of Figure 16 is described by the equation:

$$V_{OUT} = \frac{V_{REF}}{2} \cdot \left(1 + \frac{R_G}{R_{FSR}} \right)$$

The output swing of this circuit is from $(V_{REF}/2)$ to V_{REF} . In the case where R_G is greater than R_{FSR} , the output will go into positive saturation.

For either of these configurations, a zener diode placed in parallel with R_G will limit the voltage built up across R_G . These designs yield one-half the output swing of the previous circuit, but only require single sided supplies and positive reference voltages. Like the preceding circuit, the current through the FSR should be limited to less than 1 mA/square cm of applied force.

FSR Schmitt Trigger Oscillator

Figure 17: FSR Schmitt Trigger Oscillator

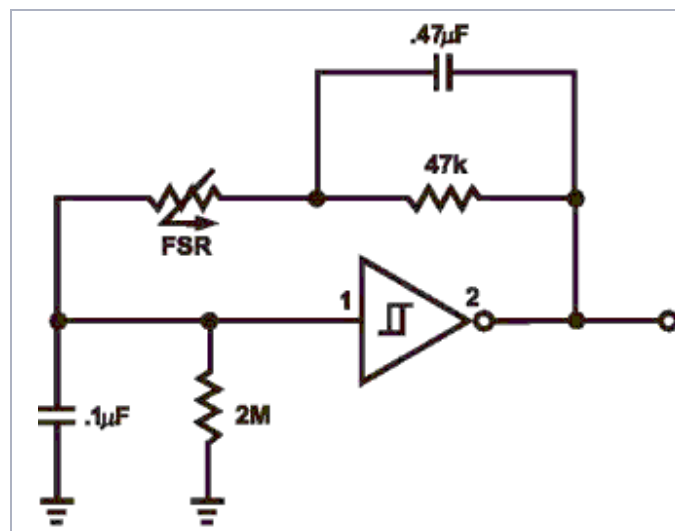

In this circuit, an oscillator is made using the FSR device as the feedback element around a Schmitt Trigger. In this manner, a simple force-to-frequency converter is made. At zero force, the FSR is an open circuit. Depending on the last stage of the trigger, the output remains constant, either high or low. When the FSR is pressed, the oscillator starts, its frequency increasing with increasing force. The $2M\Omega$ resistor at the input of the trigger insures that the oscillator is off when FSRs with non-infinite resistance at zero force are used. The $47k\Omega$ resistor and the $0.47\mu F$ capacitor control the force-to-frequency characteristic. Changes in the “feel” of this circuit can be made by adjusting these values. The $0.1\mu F$ capacitor controls the frequency range of the oscillator. By implementing this circuit with CMOS or TTL, a digital process can be controlled by counting leading and/or trailing edges of the oscillator output. Suggested Schmitt Triggers are CD40106, CD4584 or 74C14.

7.0 Performance Optimization

For best results, follow these seven steps when beginning any new product design, proof-of-concept, technology evaluation, or first prototype implementation:

1. Start with Reasonable Expectations (Know Your Sensor)

The FSR sensor is not a strain gauge, load cell, or pressure transducer. While it can be used for dynamic measurement, only qualitative results are generally obtainable. Force accuracy ranges from approximately $\pm 6\%$ to $\pm 50\%$ depending on the consistency of the measurement and actuation system, the repeatability tolerance held in manufacturing, and the extremes of the environment.

2. Choose the Sensor that Best Fits the Geometry of Your Application

Usually sensor size and shape are the limiting parameters in FSR integration, so any evaluation part should be chosen to fit the desired mechanical actuation system. In general, standard FSR products have a common response and only by varying actuation methods (e.g. overlays and actuator areas) or electrical interfaces can different response characteristics be achieved.

3. Set-up a Repeatable and Reproducible Mechanical Actuation System

When designing the actuation mechanics, follow these guidelines to achieve the best force repeatability:

- Provide a consistent force distribution. FSR response is very sensitive to the distribution of the applied force. In general, this precludes the use of dead weights for characterization since exact duplication of the weight location is rarely repeatable cycle-to-cycle. A consistent weight (force) distribution is more difficult to achieve than merely obtaining a consistent total applied weight (force). As long as the distribution is the same cycle-to-cycle, then repeatability will be maximized. The use of a thin elastomer between the applied force and the FSR can help absorb error from inconsistent force distributions.
- Keep the actuator area, shape, and material properties consistent. Changes in these parameters significantly alter the response of a given sensor. Any test, mock-up, or evaluation conditions should be closely matched to the final use conditions. The greater the cycle-to-cycle consistency of these parameters, the greater the device repeatability. In human interface applications where a finger is the mode of actuation, perfect control of these parameters is not generally possible. However, human perception of force is somewhat inaccurate so these applications may be more forgiving.
- Control actuator placement. In cases where the actuator is to be smaller than the FSR active area, cycle-to-cycle consistency of actuator placement is necessary. (Caution: an adhesive that surrounds the electrically active areas holds FSR layers together. If force is applied over an area that includes the adhesive, the resulting response characteristic will be drastically altered.) In an extreme case (e.g., a large, flat, hard actuator that bridges the bordering adhesive), the adhesive can prevent FSR actuation.

- Keep actuation cycle time consistent. Because of the time dependence of the FSR resistance to an applied force (drift), it is important when characterizing the sensor system to assure that increasing loads (e.g. force ramps) are applied at consistent rates (cycle-to-cycle). Likewise, static force measurements must take into account FSR mechanical setting time. This time is dependent on the mechanics of actuation and the amount of force applied and is usually on the order of seconds.

4. Use the Optimal Electronic Interface

In most product designs, the critical characteristic is Force vs. Output Voltage, which is controlled by the choice of interface electronics. A variety of interface solutions are detailed in the Measurement Techniques section of this guide. Summarized here are some suggested circuits for common FSR applications:

- For FSR Pressure or Force Switches, use the simple interfaces detailed on page 20.
- For dynamic FSR measurements or Variable Controls, a current-to-voltage converter (see page 21) is recommended. This circuit produces an output voltage that is inversely proportional to FSR resistance. Since the FSR resistance is roughly inversely proportional to applied force, the end result is a direct proportionality between force and voltage; in other words, this circuit gives roughly linear increases in output voltage for increases in applied force. This linearization of the response optimizes the resolution and simplifies data interpretation.

5. Develop a Nominal Voltage Curve and Error Spread

When a repeatable and reproducible system has been established, data from a group of FSR parts can be collected. Test several FSR parts in the system. Record the output voltage at various pre-selected force points throughout the range of interest. Once a family of curves is obtained, a nominal force vs. output voltage curve and the total force accuracy of the system can be determined.

6. Use Part Calibration if Greater Accuracy is Required

For applications requiring the highest obtainable force accuracy, part calibration will be necessary. Two methods can be utilized: *gain and offset trimming*, and *curve fitting*.

- Gain and offset trimming can be used as a simple method of calibration. The reference voltage and feedback resistor of the current-to-voltage converter are adjusted for each FSR to pull their responses closer to the nominal curve.
- Curve fitting is the most complete calibration method. A parametric curve fit is done for the nominal curve of a set of FSR devices, and the resultant equation is stored for future use. Fit parameters are then established for each individual FSR (or sensing element in an array) in the set. These parameters, along with the measured sensor resistance (or voltage), are inserted into the equation to obtain the force reading. If needed, temperature compensation can also be included in the equation.

7. Refine the System

False results can normally be traced to sensor error or system error. If you have any questions, contact Interlink Electronics' Sales Engineer to discuss your system and final data.

8.0 FAQ

Below are answers to our most frequently asked questions:

What are some applications in which the Interlink sensors have been used?

Interlink sensors provide economical solutions and OEM tools to a variety of force measurement applications. Our sensors have been integrated into drug delivery devices, QA/QC equipment, industrial controls, sports and recreational gear, and more.

How much do the system and sensors cost?

Pricing varies and Interlink Electronics or an authorized distributor quotes it.

What is your return policy?

Package must be returned unopened within 48 hours of receipt of merchandise.

How does the sensor react to force? Is the resistance constant, or is it decreasing with a constant value?

The inks in our sensors are resistive: the greater the force, the less the resistance.

How much can I overload the sensor without damaging it?

Although polymer substrates deform plastically around 10,000 PSI (69N/mm²), we generally regard the threshold of damage to be much lower. A safe guideline is to maintain the total pressure on the sensor below 10N/mm² of actuator area.

What is the lifetime of a Interlink sensor?

The durability of the Interlink sensor depends on the conditions to which it is exposed: magnitude of the load, the interface material, and the direction of the load (minimal shear). The sensor is typically operational beyond 1,000,000 actuations.

What materials/conditions could damage the sensor?

Temperatures >215.55°C (420°F), water-submersion (as the adhesive holding the top & bottom layers together would likely separate), sharp objects, shear forces, creasing the sensor, and loads that are around or above 10N/mm² can damage the sensor.

Can I fold the sensor?

The sensor is designed to be flexible; however the sensing area should not be folded as this causes shearing. The traces should not be bent more than 90° as the silver conductive leads could break.

Can I adhere the sensor to a surface?

If you need to adhere the sensor to a surface, a thin, double-sided tape is recommended. Often the sensors are supplied with such adhesive, covered with a removable liner.

What surface is best to use underneath the sensor?

A flat, smooth surface is ideal. Trapped air bubbles or dirt particles can cause the sensor to appear loaded in the absence of an external load.

What drive voltages can I apply to the sensor?

Electrically the sensors look like passive resistors. Any voltage that suits your circuit is fine. From 0.1V (as long as signal-to-noise (S/N) ratio remains acceptable) to 5V is the typical range.

What is the resistance range of the sensor?

The resistance range of the sensor is typically from >1MΩ at no load to approximately 1kΩ at full load. This can vary depending on the details of the sensor and actuating mechanics.

How long must the sensor be unloaded before you load it again?

There is no exact or estimated time.

Are the Interlink sensors waterproof?

No, the sensors are not designed for use under water. The FSR material is not compatible with direct liquid contact. Sensors are ideally suited to placement behind a waterproof enclosure.

What is soldering conditions for FSR400 with solder tab?

When soldering on the solder tab, in order to avoid any damage from high soldering temperature, please follow below recommendation.

- Set the solder iron temperature at 380°C±10°C
- Soldering time is less than one second
- Metal sink fixture is suggested as shown below picture.
- After soldering, check visually if there is any shrinkage on the tail area which caused by heat

Note: Make sure the metal lever touch the solder tabs in order to prevent heat from transferring to sensor during soldering.

FSR Soldering Fixture

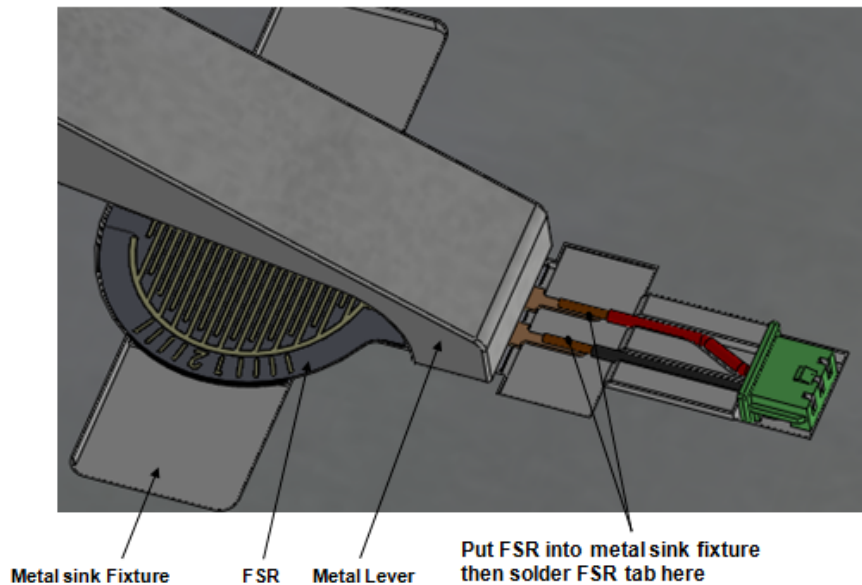

Does humidity have any effect on the sensor?

Yes, of all environmental extremes humidity causes the most change. Extreme humidity, for example 85 RH at 85C for hundreds of hours, will shift resistance dramatically upward.

Can the sensors pick up electrical noise?

FSRs are no more prone to noise pickup than a passive resistor, although they can have considerable surface area. Proximity to high intensity RF sources may require special measures.

What is the smallest active sensing area you can make?

The minimum head dimension for our sensors can be 5mm (3mm active area).

What are the minimum and maximum quantities you can do annually?

Due to the cost involved, we typically do not design custom sensors for when expected volumes are low. The maximum quantities that can be produced depend on several factors. We have produced specific sensors in volumes as high as 20M pieces per year.

What is the average cost of a custom design?

Each request is different, depending on size, complexity of design, force ranges, quantities, etc. Contact an Interlink sales agent for pricing.

9.0 FSR Usage: The Do's and Don'ts

- **Do** follow the seven steps of the FSR Integration Guide.
- **Do**, if possible, use a firm, flat and smooth mounting surface.
- **Do** be careful if applying FSR devices to curved surfaces. Pre-loading of the device can occur as the two opposed layers are forced into contact by the bending tension. The device will still function, but the dynamic range may be reduced and resistance drift could occur. The degree of curvature over which an FSR can be bent is a function of the size of the active area. The smaller the active area, the less effect a given curvature will have on the FSR's response.
- **Do** avoid air bubbles and contamination when laminating the FSR to any surface. Use only thin, uniform adhesives, such as Scotch brand double-sided laminating adhesives. Cover the entire surface of the sensor.
- **Do** be careful of kinks or dents in active areas. They can cause false triggering of the sensors.
- **Do** protect the device from sharp objects. Use an overlay, such as a polycarbonate film or an elastomer, to prevent gouging of the FSR device.
- **Do** use soft rubber or a spring as part of the actuator in designs requiring some travel.
- **Do not** kink or crease the tail of the FSR device if you are bending it; this can cause breaks in the printed silver traces. The smallest suggested bend radius for the tails of evaluation parts is about 2.5 mm. In custom sensor designs, tails have been made that bend over radii of 0.8 mm. Also, be careful if bending the tail near the active area. This can cause stress on the active area and may result in pre-loading and false readings.
- **Do not** block the vent. FSR devices typically have an air vent that runs from the open active area down the length of the tail and out to the atmosphere. This vent assures pressure equilibrium with the environment, as well as allowing even loading and unloading of the device. Blocking this vent could cause FSRs to respond to any actuation in a non-repeatable manner. Also note that if the device is to be used in a pressure chamber, the vented end will need to be kept vented to the outside of the chamber. This allows for the measurement of the differential pressure.
- **Do not** solder directly to the exposed silver traces. With flexible substrates, the solder joint will not hold and the substrate can easily melt and distort during the soldering. Use Interlink Electronics standard connection techniques, such as solderable tabs, housed female contacts, Z-axis conductive tapes, or ZIF (zero insertion force) style connectors.
- **Do not** use cyanoacrylate adhesives (e.g. Krazy Glue) and solder flux-removing agents. These degrade the substrate and can lead to cracking.
- **Do not** apply excessive shear force. This can cause delamination of the layers.
- **Do not** exceed 1mA of current per square centimeter of applied force (actuator area). This can irreversibly damage the device.



10.0 Glossary

Terminology

Active Area: The area of an FSR device that responds to normal force with a decrease in resistance. This is typically the central area of the sensor more than 0.5mm from the inside edge of the spacer.

Actuator: An object that contacts the sensor surface and applies force to FSRs.

Applied Force: The force applied by the actuator on the sensor active area.

Array: Any grouping or matrix of FSR sensors that can be individually actuated and measured, usually all built together as a unit.

Break Force: The minimum force required, with a specific actuator size, to cause the onset of the FSR response. Typically defined as the force required to reach below 100kΩ.

Cross-talk: Measurement noise or inaccuracies of a sensor as a result of the actuation of another sensor on the same substrate. See also false triggering.

Drift: The change in resistance with time under a constant (static) load. Also called resistance drift.

Durometer: The measure of the hardness of rubber.

EMI: Electromagnetic interference.

ESD: Electrostatic discharge.

False triggering: The unwanted actuation of a FSR device from unexpected stimuli; e.g., bending or cross talk.

Force Resolution: The smallest measurable difference in force.

FSR: Force Sensing Resistor. A polymer thick film device with exhibits a decrease in resistance with an increase in force-applied normal to the device surface.

Graphic Overlay: A printed substrate that covers the FSR. Usually used for aesthetics and protection.

Housed Female: A stitched on AMP connector with a receptacle (female) ending. A black plastic housing protects the contacts. Suitable for removable ribbon cable connector and header pin attachment.

Hysteresis: In a dynamic measurement, the differences between instantaneous force measurements at a given force for an increasing load versus a decreasing load.

Repeatability: The ability to repeat, within a tolerance, a previous response characteristic.



Response Characteristic: The relationship of force or pressure vs. resistance.

Saturation Pressure: The pressure level beyond with the FSR response characteristic deviates from its inverse power law characteristic. Past the saturation pressure, increases in force yield little or no decrease in resistance.

Spacer Adhesive: The adhesive used to laminate FSR devices tighter. Dictates stand-off.

Standoff: The gap or distance between the opposed polymer film layers when the sensor is unloaded and unbent.

Standoff Resistance: The FSR resistance when the device is unloaded and unbent.

Substrate: Any base material on which the FSR semi-conductive or metallic polymers are printed. (For example, polyetherimide, polyethersulfone and polyester films).

Tail: The region where the lead out or busing system terminates. Generally, the tail ends in a connector.

11.0 Intellectual Property & Other Legal Matters

Interlink Electronics holds several domestic and international patents for its Force Sensing Resistor technology. FSR and Force Sensing Resistor are company trademarks. All other trademarks are the property of their respective owners.

The product information contained in this document provides general information and guidelines only and must not be used as an implied contract with Interlink Electronics. Acknowledging our policy of continual product development, we reserve the right to change, without notice, any detail in this publication. Since Interlink Electronics has no control over the conditions and method of use of our products, we suggest that any potential user confirm their suitability for their own application.

12.0 Contact Interlink Electronics

United States

Corporate Office

Interlink Electronics, Inc.
546 Flynn Road
Camarillo, CA 93012, USA
Phone: +1-805-484-8855
Fax: +1-805-484-9457
Web: www.interlinkelectronics.com
Sales and support: sales@interlinkelectronics.com

Japan

Japan Sales Office

Kannai-Keihin Bldg. 10F/1004
2-4-2 Ougi-cyo, Naka-ku
Yokohama-shi, Kanagawa-ken 231-0027
Japan
Phone: +81-45-263-6500
Fax: +81-45-263-6501
Web: www.interlinkelec.co.jp