

9001 Series Over Current Detector

Circuit Examples

Introduction

The 9001 overcurrent detector has been designed with the intended application of protecting power semiconductors in power electronic circuits. As such, its application is not limited to one type of power circuit, but instead circuit where power semiconductors are used. It combines small size, an isolated output, and fast response time with a low price to provide an effective means for protecting power semiconductors against over current conditions.

This application note is intended to illustrate application of the detector in typical power electronic circuits. These examples include:

- 3 Phase Inverter
- Single Phase Inverter
- Single Phase Inverter with Parallel MOSFET's
- High Frequency Half Bridge Converter
- Brush DC Motor Control

This application note is not an exhaustive illustration however, it should facilitate application to other power circuits.

Detector Highlights

The 9001 over current detector is an ideal choice for over current sensing in today's sophisticated power electronic circuits. It provides isolation between the sensed current and the output signal. An isolated power supply is not required to power the sensor, even when sensing current which is above or below the ground potential. It has a digital open collector type output which goes low when the current exceeds the detector trip threshold. Because this is a digital output, it is easily filtered with only a very small effect on the response time of the output signal. Thus, over current conditions are typically signaled in 1 μ S, providing plenty of headroom for system control circuitry to protect the power circuitry. Since the detector is Hall effect based, it has a negligible level of power dissipation. This remains true in high frequency switching circuits as well.

Comparison to Current Shunt Sensing

Current shunt sensing is used in many existing power electronic circuits. This method passes the sensed current through a resistor. The voltage across the resistor is then compared to a reference in a comparator or op amp to determine if the current has exceeded a safe threshold. The primary advantage of this method is that it is relatively low cost particularly at low power levels. However, it also comes with some problems:

- 1.) It does not provide isolation so it is typically used to measure current in the ground bus. If measuring current at any other voltage potential, an isolated power supply and signal interface is required.
- 2.) Even if used in the ground bus, as current levels and switching speeds increase, the shunt generates significant levels of conducted EMI which can have an adverse impact on sensitive control circuitry.
- 3.) Noise generated across the shunt requires filtering which slows the response time of the detection circuit
- 4.) The size of the shunt can often preclude mounting on the printed circuit board - Increasing assembly time, labor costs and have a negative impact on the level of quality.
- 5.) The power dissipated in the shunt becomes a more significant problem at higher current levels

All of these problems are significantly reduced or eliminated entirely with the use of an over current detector. This is done at a price which makes it a competitive choice for sensing over currents at much lower power levels than was previously possible with more expensive magnetic type sensors.

Circuit Example 1: Three Phase Inverter

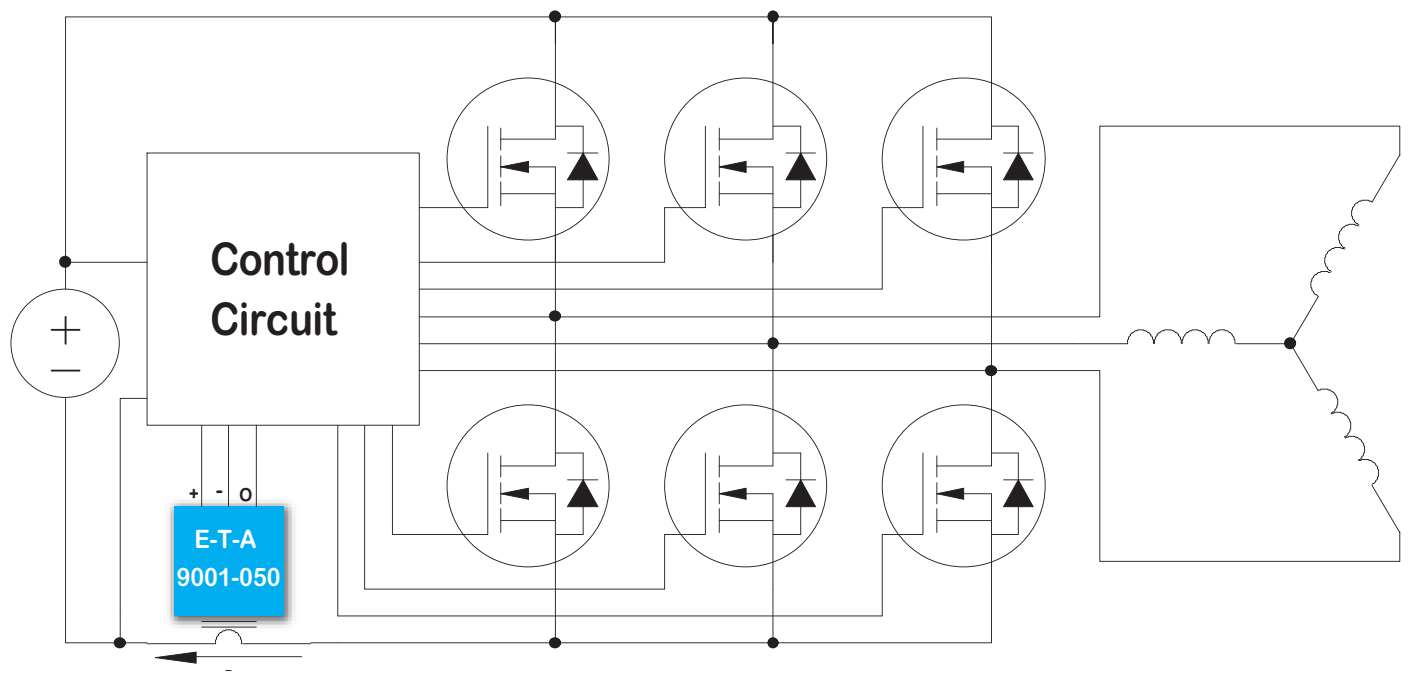

In this circuit, current must be sensed in the bridge to protect the power transistors against over current conditions. The over current conditions can be caused by transient loads on the output of the inverter, or shoot through conditions caused by noise in the control circuitry or intermittent logic problems.

In an ideal world, a sensor would be used on each transistor or at least on each phase or pole of the inverter. But this is difficult to justify from a cost perspective, even with the cheapest of sensing solutions. A good compromise between cost and reliability is to sense current in the ground bus.

The schematic shows the over current detector in the ground bus. The output of the detector is connected to the circuit's control logic. In the case of an over current event, the control logic shuts down the bridge for a programmed off time period via the drive signals to the transistors. Often, this shutdown time only needs to be $\sim 100 \mu\text{s}$. By having a short off time, the shutdown of the bridge is typically imperceptible to the outside observer. The control circuit can be designed to count over current events within a window of time. A high number of events is indicative of an over load condition, or even a failed transistor within the bridge. In this case, the bridge can be shut down for service. This prevents catastrophic destruction of the inverter and facilitates a much quicker determination of the root cause of the problem.

Circuit Example 2: Single Phase Inverter

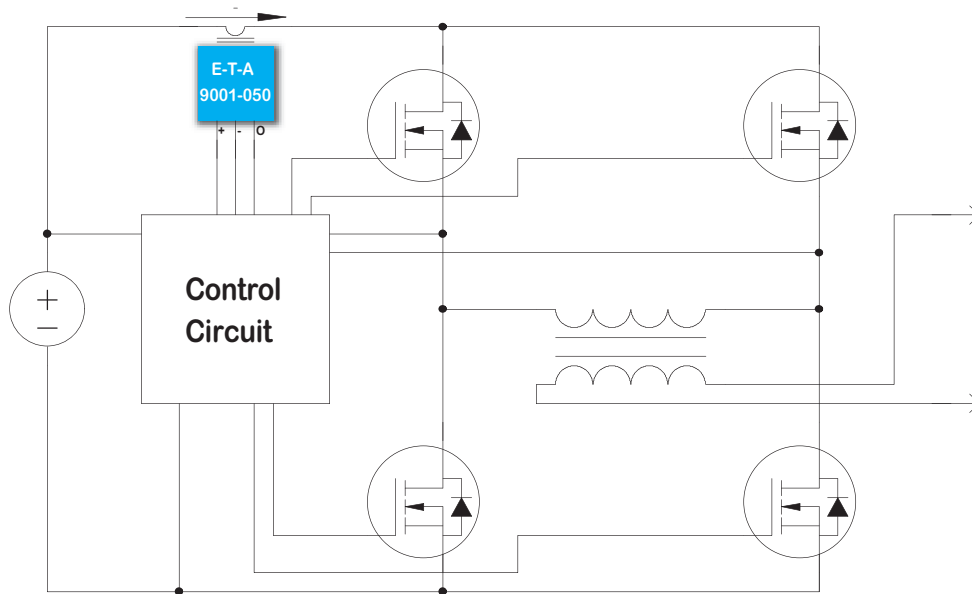

This application is similar to the three phase inverter. In this case, the detector is shown in the positive bus to the bridge, although it could have been just as easily placed in the ground bus. It makes no difference from a circuit perspective. However, from a packaging perspective, it provides some flexibility. This flexibility in placement can prove to be an advantage during the printed circuit board layout phase of the design.

Circuit Example 3: Single Phase Inverter with Parallel MOSFET's

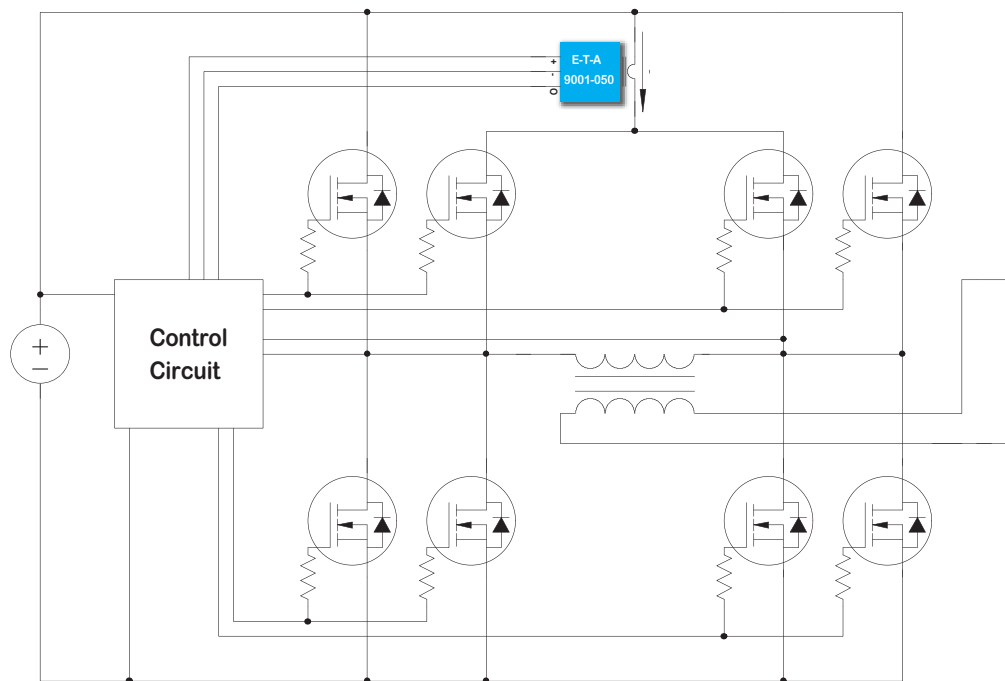

In this circuit, two FET's are paralleled to form each switch group. In this case, as in the previous two, the detector could be placed in either the positive or negative buses. The problem with this is that the detector and the conductor passing the sensed current must be rated for the entire bridge current. A more economical approach is to locate the detector so that it senses the current in one FET from each of either the top or bottom switch groups. The schematic shows this for the top case. This approach provides a relatively small detector to be used even for bridges that might parallel 10 or 12 transistors per switch group. It also works effectively with FET's as they share current very well.

Circuit Example 4: High Frequency Half Bridge Converter

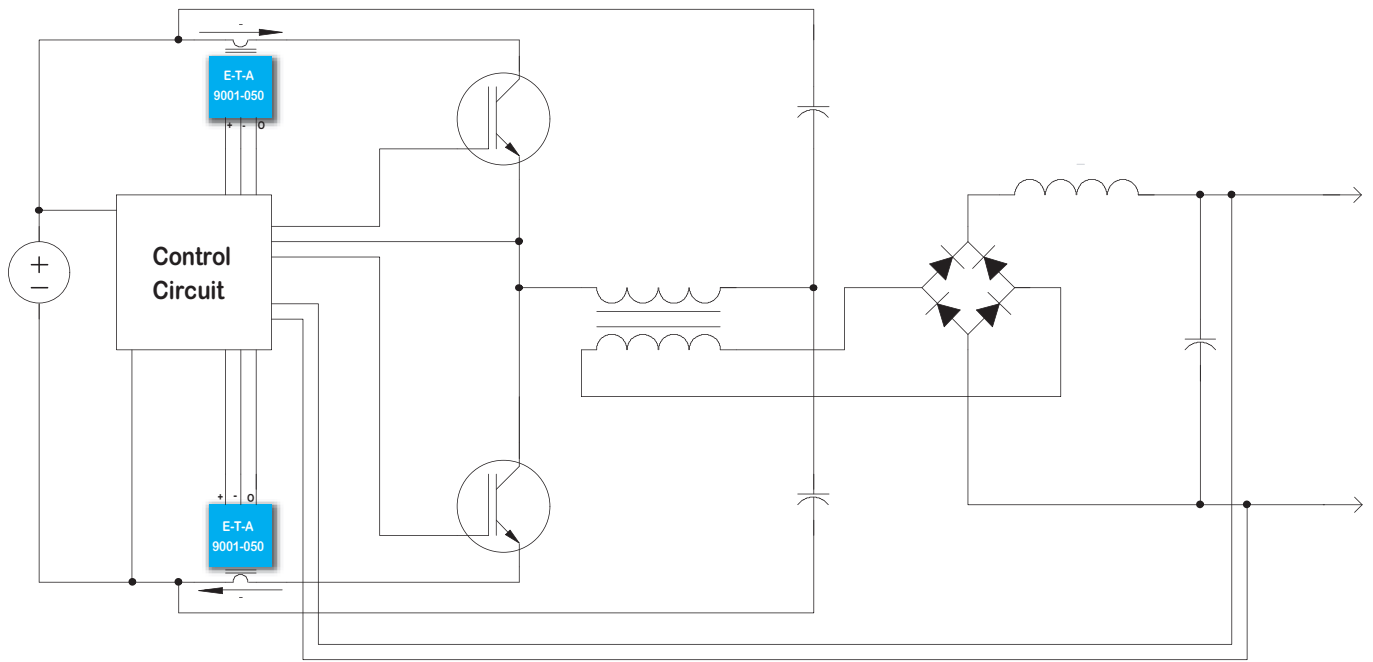

In this schematic of a high frequency half bridge IGBT based converter, two detectors are used to provide protection against over currents due to a variety of conditions. These include: shoot through, transformer saturation, output overload and transient output conditions.

Circuit Example 5: Brush DC Motor Control

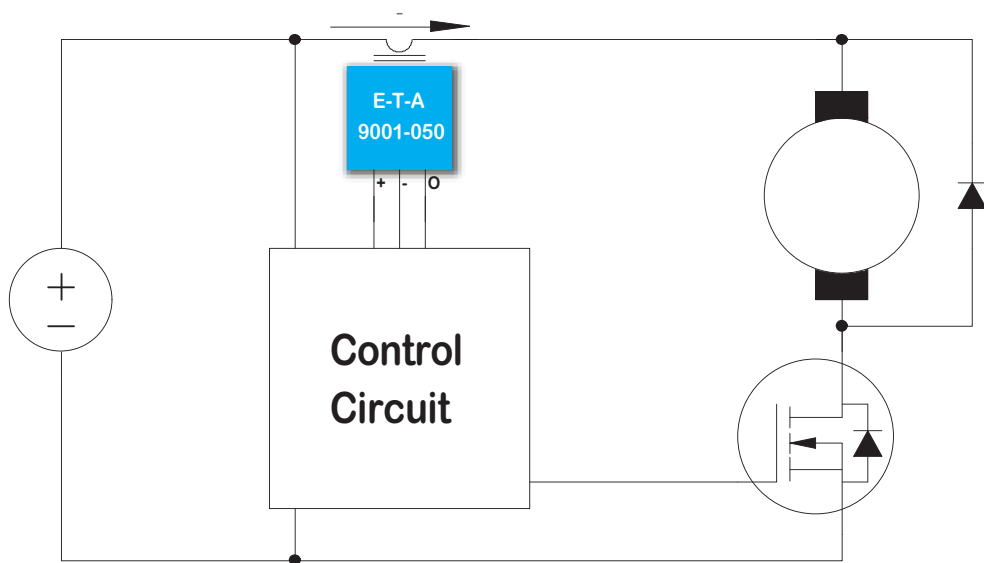

In this case, the detector can be located in the positive bus, between the negative side of the motor and the FET, or in the negative bus. All three locations provide equivalent protection. Similar to Example 2, the placement of the detector may be dictated by space considerations during the printed circuit board layout phase of the design.