

Sealed Industrial Ethernet Circular IP67 Cat. 5e RJ45 Connector System Assembly Instructions

CONEC Industrial Ethernet Circular Sealed RJ45 Connector System consists of a **RJ45 Plug Kit**, a **Receptacle Kit** and a **Protective Cover Assembly**.

1. The RJ45 Plug Kit

1.1 Introduction

The RJ45 plug kit consists of a shielded 8 position **Cat. 5e RJ45 Plug**, a **Load Bar** and a **Plug Housing Assembly (Bayonet)**. There are 3 different versions available for the **Plug Housing Assembly**, plastic, metallized plastic and Zinc Die-cast. See Figure 1-1 for details.

Figure 1-1: RJ45 Plug Kit

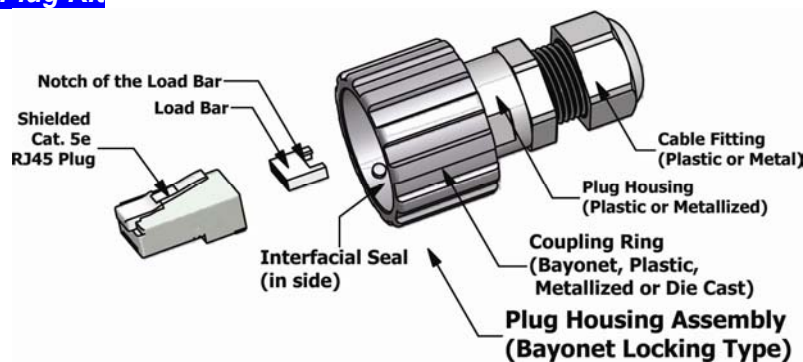

Plastic Version	P/N: 17-10001
Metallized Plastic Version	P/N: 17-10013
Zinc Die-cast Version	P/N: 17-10044

2 Cable Strain Relief Kit

2.1 Introduction

The RJ45 cable strain relief kit consists of a shielded 8 position **Cat. 5e RJ45 Plug**, a **Load Bar** and a **Plug Housing Assembly (Thread)**. There are 2 different versions available for the **Plug Housing Assembly**, plastic and metallized plastic. See Figure 2-1 for details.

Figure 2-1: RJ45 Cable Strain Relief Kit

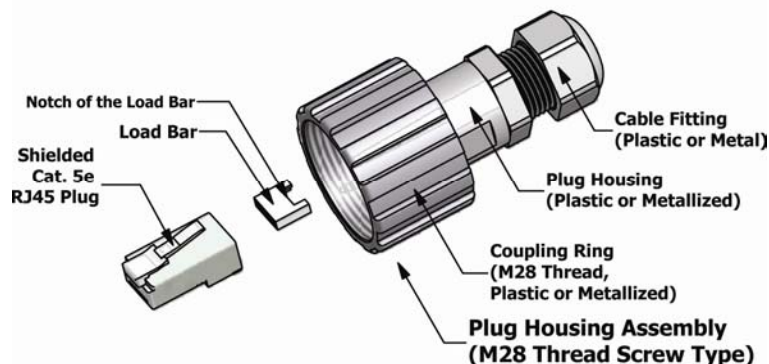

Plastic Version	P/N: 17-100464
Metallized Plastic Version	P/N: 17-100474

The RJ45 plug accepts both stranded and solid cables. It can be IDC terminated with the termination tool. The load bar aligns the wires for insuring easy and proper assembly.

3 Cat. 5e Shielded and Unshielded Cable

The following specified category 5e 100Ω shielded and unshielded twisted pair cables (STP and UTP) is suitable for use with the RJ45 Plug Kit. Plastic version of the cable fitting accepts cables with an outer diameter range of 4mm to 8mm while 4.5mm to 8mm for the metallized plastic version.

A. Stranded Wire

Cable type: 8 positions
Conductor size: 24 AWG
Conductor type: 7 strand copper
Contact insulator diameter: 0.99mm maximum
RJ45 plug accepts cable outer diameter range: 4.83mm ~ 6.73mm

B. Solid Wire

Cable type: 8 positions
Conductor size: 24 AWG
Conductor type: copper
Contact insulator diameter: 0.99mm maximum
RJ45 plug accepts Loose, Pliable cable outer diameter range: 4.83mm ~ 6.73mm
RJ45 plug accepts Hard, Rigid cable outer diameter range: 4.83mm ~ 5.08mm

3.1 Cable Preparation

3.1.1 Cable jacket should be stripped with the proper length as shown in figure 3-1 and then inserted through the cable fitting and the plug housing assembly.

Figure 3-1: Cable Preparation Step 1

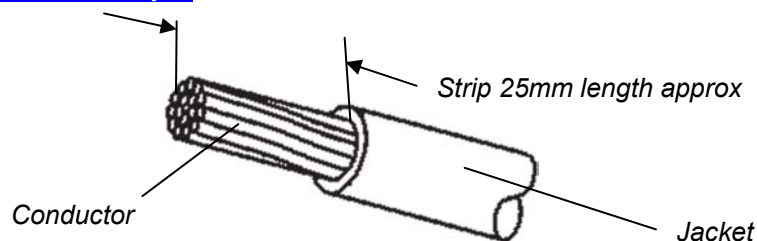

3.1.2 Conductor pair should be untwisted and aligned side-by-side according to EIA/TIA **T568A** or **T568B** (defined in Figure 3-2 and Table 1-1) and the conductor tips should be trimmed as shown in Figure 3-3. Please note that insulation of individual conductors must not be removed.

Figure 3-2: EIA/TIA T568A & T568B Plug Positions

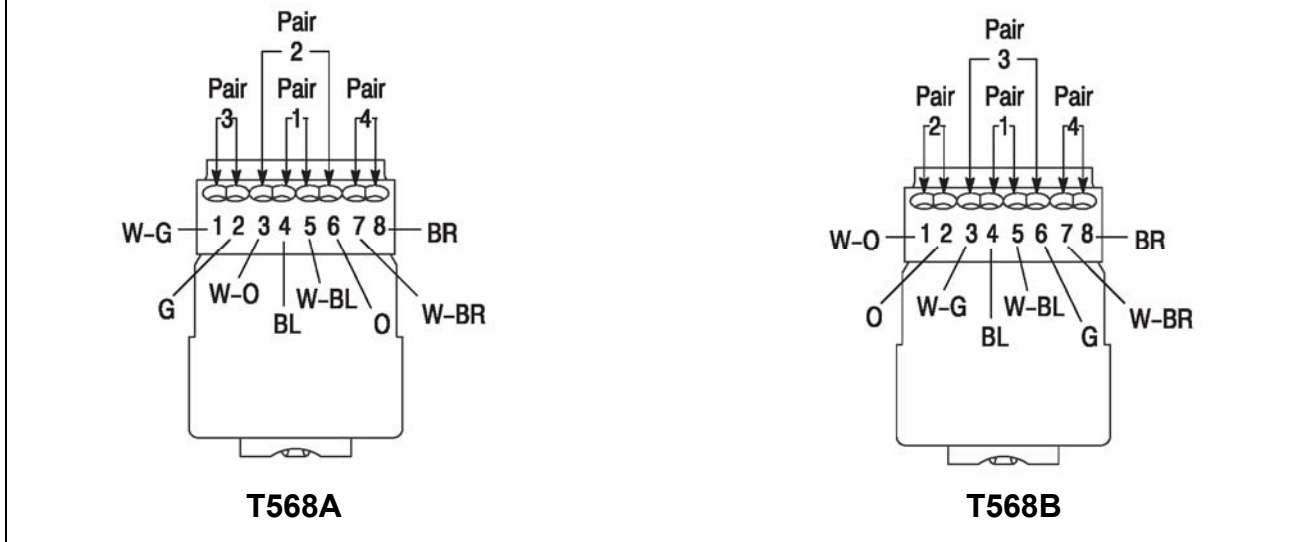
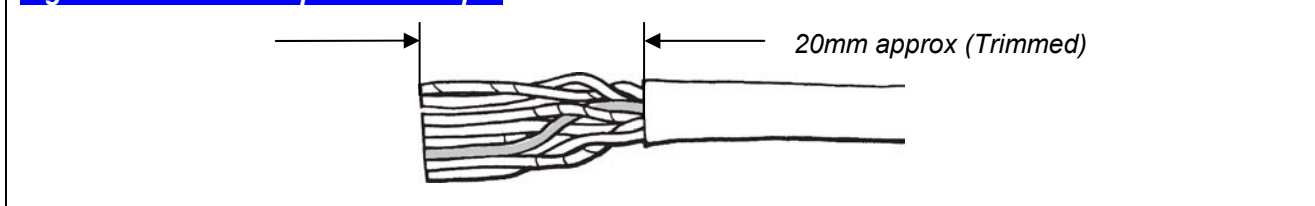

Table 1-1: TIA/EIA T568A & T568B Conductor Pairs and Wire Colors

Conductor Pair	Conductor Pair Definitions		Wire Color Code (Abbreviation)	
	T568A	T568B	Option 1	Option 2
Pair 1	4	4	Blue (BL)	Red (R)
	5	5	White-Blue(W-BL)	Green (G)
Pair 2	3	1	White-Orange (W-O)	Black (BK)
	6	2	Orange (O)	Yellow (Y)
Pair 3	1	3	White-Green (W-G)	Blue (BL)
	2	6	Green (G)	Orange (O)
Pair 4	7	7	White-Brown (W-BR)	Brown (BR)
	8	8	Brown (BR)	Slate (S)

Figure 3-3: Cable Preparation Step 2



3.2 Termination

3.2.1 After inserting the wires into the appropriate positions of the load bar, slide the cable to a point where the cable jacket hits against the notch of the load bar. Trim the remaining wire ends to approximately 5mm length of the wire tips as shown in **Detail A** of Figure 3-4. Retract the cable, leaving about 1mm length of the wire tips as shown in **Detail B** of Figure 3-4.

Figure 3-4: Insert Conductors into the Load bar

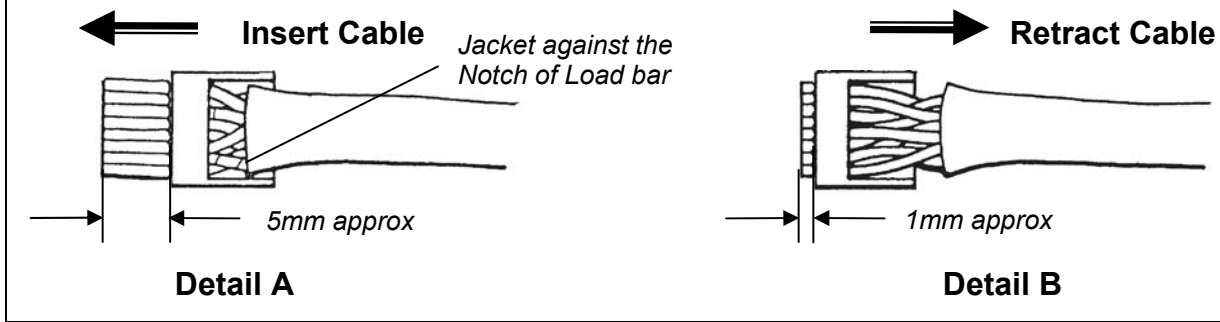

3.2.2 Insert the wired load bar into the RJ45 plug all the way until the wire tips are seated against the inside wall of the plug housing (Figure 3-5A). For shielded version adjust the drain wires of the cable to touch the metal shell of the RJ45 Plug (Figure 3-5B). Cut out extra drain wire after termination.

Figure 3-5A: Insert the wired load bar into plug

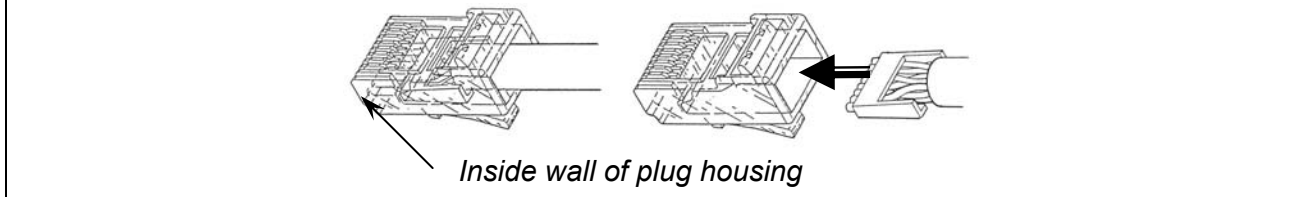
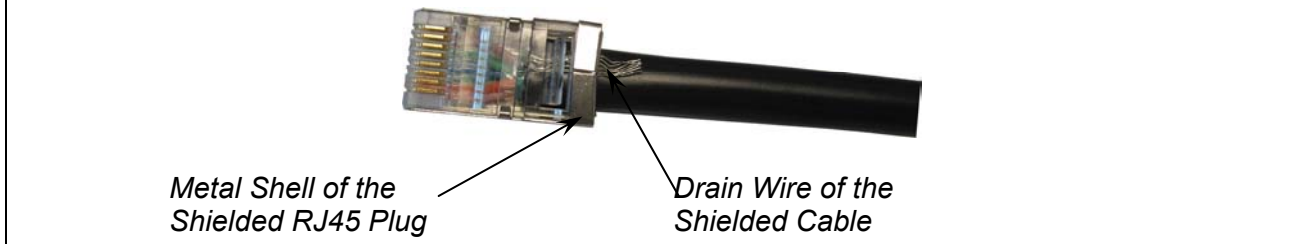
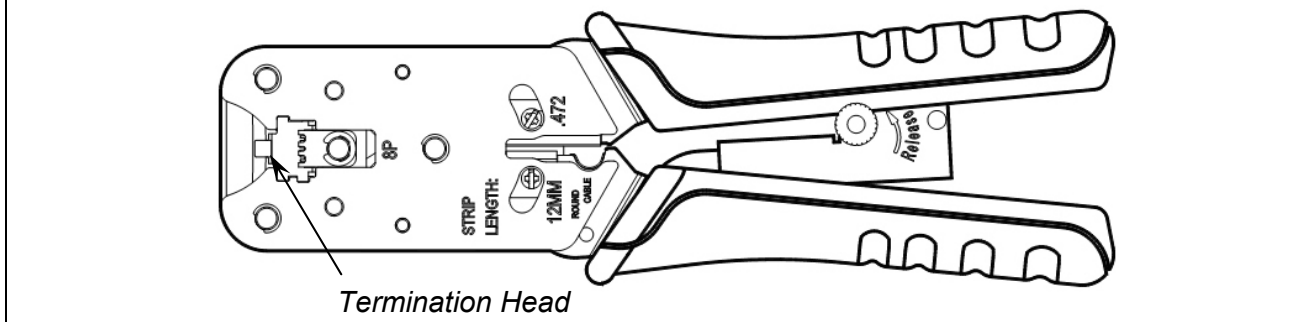

Figure 3-5B: Place the drain wire of the cable to touch the metal shell of the shielded plug



3.2.3 Terminate the cable and the RJ45 Plug with CONEC 8P8C modular plug termination tool (Figure 3-6). Depress the locking tab of the plug, insert the plug and cable into the termination head up to the end of the inside plug housing wall and terminate. Depress the locking tab of the plug and pull the plug from the tool after termination.

Figure 3-6: 8P8C Modular Plug Termination Tool (P/N: 360X30029X)



3.2.4 Test the pin configuration of the assembled cable for accuracy using the **NETWORK Multi-Modular Cable Tester** (Figure 3-7).

Figure 3-7: Network Multi-Modular Cable Tester (P/N: 360X30039X)

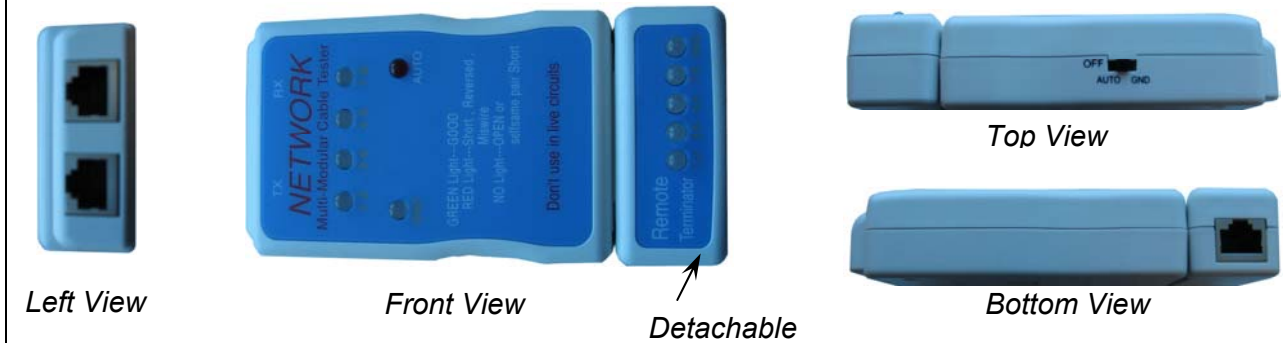
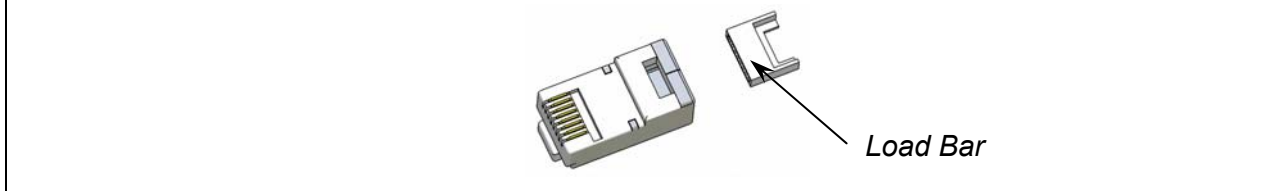

Figure 3-8: Shielded Cat. 5e RJ45 Plug (P/N: 391J00039X)



The **Modular Plug Termination Tool** (Figure 3-6), the **NETWORK Multi-Modular Cable Tester** (Figure 3-7) and the **RJ45 Plug** (Figure 3-8) can be ordered separately.

4 Assembly of the RJ45 Plug Housing

Depress the locking tab of RJ45 Plug and align it with the wide slot of the plug housing shown in **Detail A** of Figure 4-1. Gently pull the cable until the plug is fully seated. Hold the plug in position and rotate the cable fitting until tightened to a torque of 2.27 Nm (20 lb-in). See **Detail B** of Figure 4-1.

Figure 4-1: Assembly of the RJ45 Plug Housing

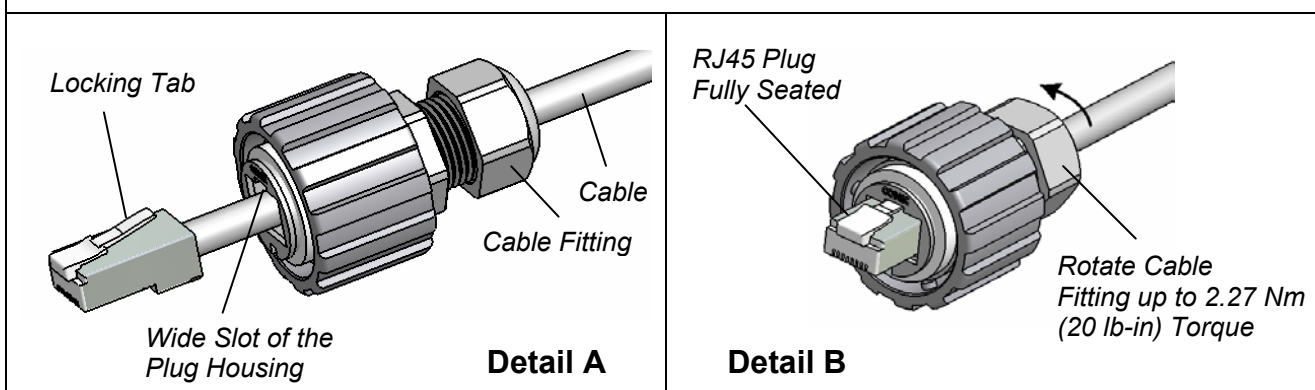

5. The Receptacle Assembly Kit

5.1 The Cat. 5e RJ45 Inline Coupler Receptacle Assembly Kit

This Receptacle Assembly kit consists of a **RJ45 Inline Coupler Receptacle Assembly**, a **Panel Gasket** and a **Panel Nut**. There are plastic and metallized plastic versions available for the *Receptacle Housing*. See Figure 5-1 for details.

Figure 5-1: Cat. 5e RJ45 Inline Coupler Receptacle Assembly Kit

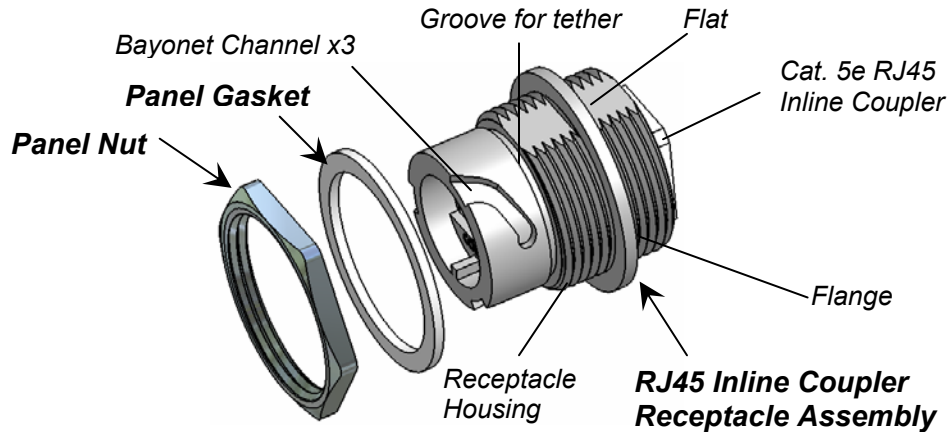

Plastic Version with Shielded Cat. 5e RJ45 Inline Coupler	P/N: 17-10009
Plastic Version with Unshielded Cat. 5e RJ45 Inline Coupler	P/N: 17-10019
Metallized Plastic Version with Shielded Cat. 5e RJ45 Inline Coupler	P/N: 17-10012

5.2 The Cat. 5e RJ45 IDC Jack Receptacle Assembly Kit

This Receptacle Assembly kit consists of a **RJ45 IDC Jack Receptacle Assembly**, a **Panel Gasket** and a **Panel Nut**. There are plastic and metallized plastic versions available for the *Receptacle Housing*. See Figure 5-2 for details.

Figure 5-2: Cat. 5e RJ45 IDC Jack Receptacle Assembly Kit

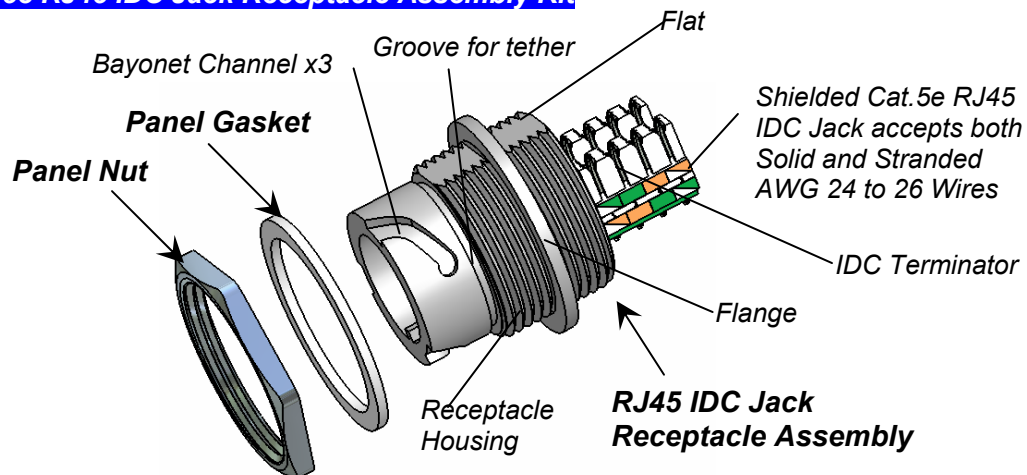

Plastic Version with Shielded Cat. 5e RJ45 IDC Jack	P/N: 17-10015
Metallized Plastic Version with Shielded Cat. 5e RJ45 IDC Jack	P/N: 17-10016
Fully Potted Plastic Version with Shielded Cat. 5e RJ45 IDC Jack	P/N: 17-10033
Fully Potted Metallized Plastic Version with Shielded Cat. 5e RJ45 IDC Jack	P/N: 17-10034

Use the 110 type punch-down tool (Figure: 5-3) to terminate the wires to the IDC terminator of the IDC Jack.

Figure 5-3: 110 Type Punch-Down Tool (P/N: 360X30049X)



5.3 The Cat. 5e RJ45 PCB Jack Receptacle Assembly Kit

This Receptacle Assembly kit consists of a **RJ45 IDC Jack Receptacle Assembly**, a **Panel Gasket** and a **Panel Nut**. This PCB version is designed to solder the wires direct onto the PCB of the Jack. There are plastic and metallized plastic versions available for the **Receptacle Housing**. See Figure 5-4 for details.

Figure 5-4: Cat. 5e RJ45 PCB Jack Receptacle Assembly Kit

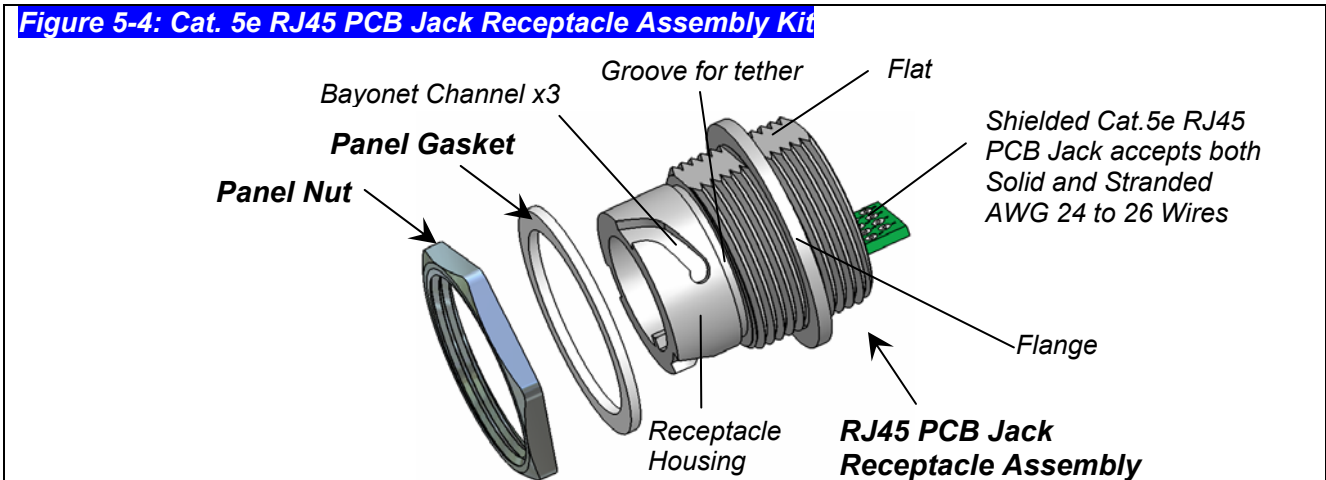

Plastic Version with Shielded Cat. 5e RJ45 PCB Jack	P/N: 17-10017
Metallized Plastic Version with Shielded Cat. 5e RJ45 PCB Jack	P/N: 17-10018
Fully Potted Plastic Version with Shielded Cat. 5e RJ45 PCB Jack	P/N: 17-10035
Fully Potted Metallized Plastic Version with Shielded Cat. 5e RJ45 PCB Jack	P/N: 17-10036

6 Protective Cover Assembly

6.1 Introduction

The **Protective Cover Assembly** consists of a **Cover Coupling Ring**, a **Cover Gasket** and a **Tether**. There are plastic and metallized plastic versions available for the **Cover Coupling Ring** housing. See Figure 6-1 for details.

Figure 6-1: Protective Cover Assembly

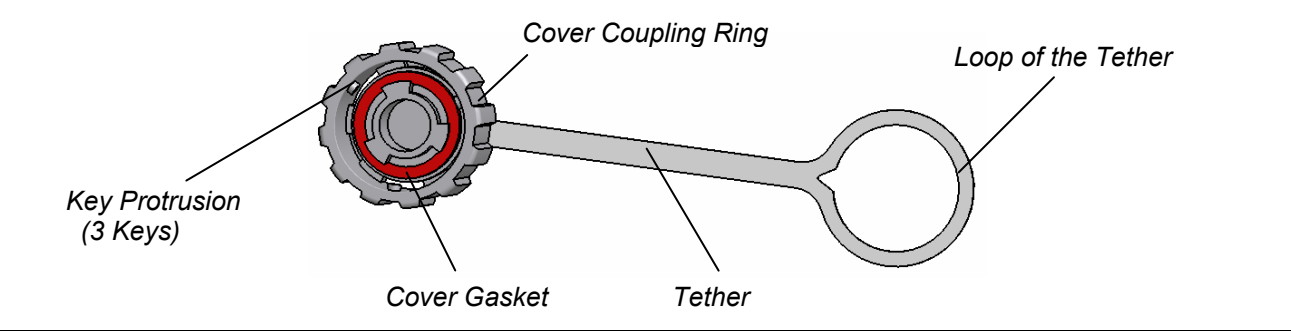

Plastic Version	P/N: 17-10002
Metallized Plastic Version	P/N: 17-10014

7. The Receptacle + Protective Cover Assembly Kit

7.1 Introduction

This kit combines the different version of the **Receptacle Assembly** and the different version of the **Protective Cover Assembly**. See Figure 7-1 for details.

Figure 7-1: Receptacle + Protective Cover Assembly Kit

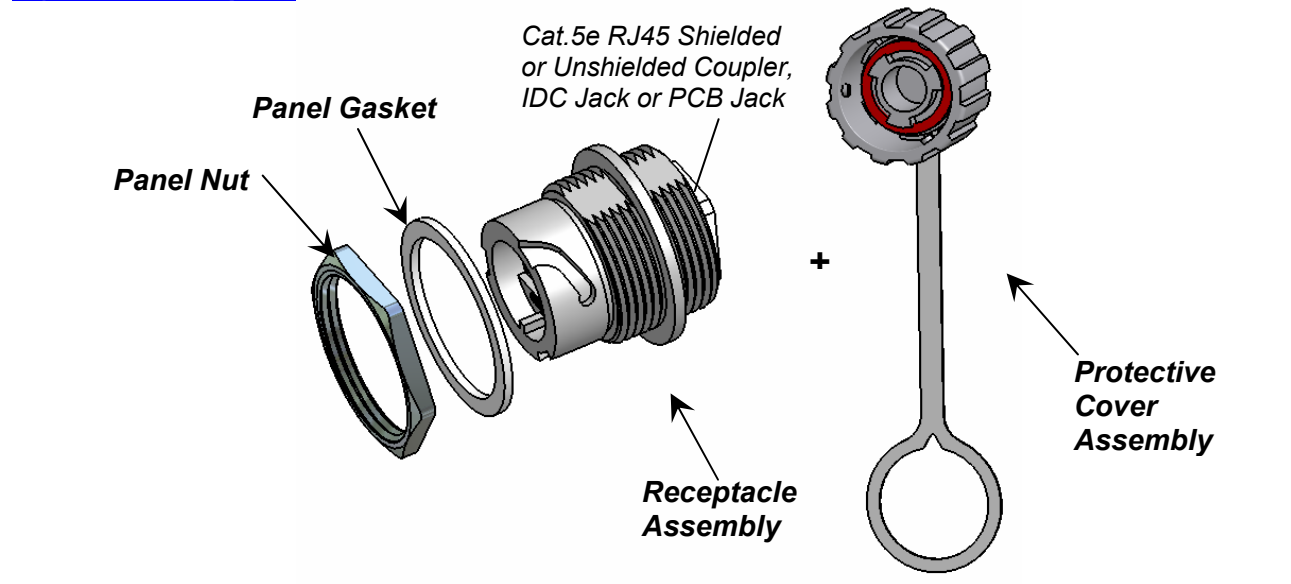

Plastic Version with Shielded Inline Coupler + Protective Cover	P/N: 17-10000
Plastic Version with Unshielded Inline Coupler + Protective Cover	P/N: 17-10020
Metallized Plastic Version with Shielded Inline Coupler + Protective Cover	P/N: 17-10011
Plastic Version with Shielded IDC Jack + Protective Cover	P/N: 17-10021
Metallized Plastic Version with Shielded IDC Jack + Protective Cover	P/N: 17-10022
Plastic Version with Shielded PCB Jack + Protective Cover	P/N: 17-10023
Metallized Plastic Version with Shielded PCB Jack + Protective Cover	P/N: 17-10024
Fully Potted Plastic Version with Shielded IDC Jack + Protective Cover	P/N: 17-10037
Fully Potted Metallized Plastic Version with Shielded IDC Jack + Protective Cover	P/N: 17-10038
Fully Potted Plastic Version with Shielded PCB Jack + Protective Cover	P/N: 17-10039
Fully Potted Metallized Plastic Version with Shielded PCB Jack + Protective Cover	P/N: 17-10040

8 Panel Cutout

8.1 Introduction

A panel thickness of up to 3.20mm may be used. The recommended panel cutout dimension is shown on Figure 8-1.

Figure 8-1: Recommended Panel Cutout

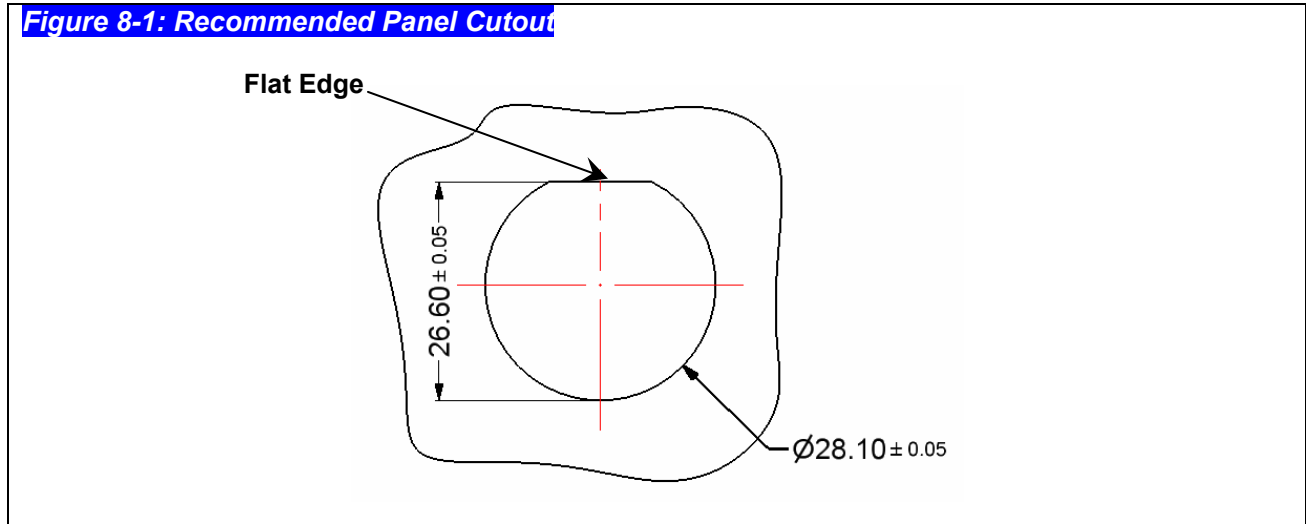

8.2 Panel Mounting

The receptacle is designed for front or rear panel mounting as shown in **Detail A** and **Detail B** of Figure 8-2. The panel nut should be tightened to a torque of 2.27 Nm (20 lb-in).

The **Protective Cover** must be installed onto the **Receptacle Assembly** and cover the receptacle immediately for insuring the IP67 sealing performance once the **Plug Assembly** is removed from the receptacle.

Figure 8-2: The Receptacle Panel Mounting

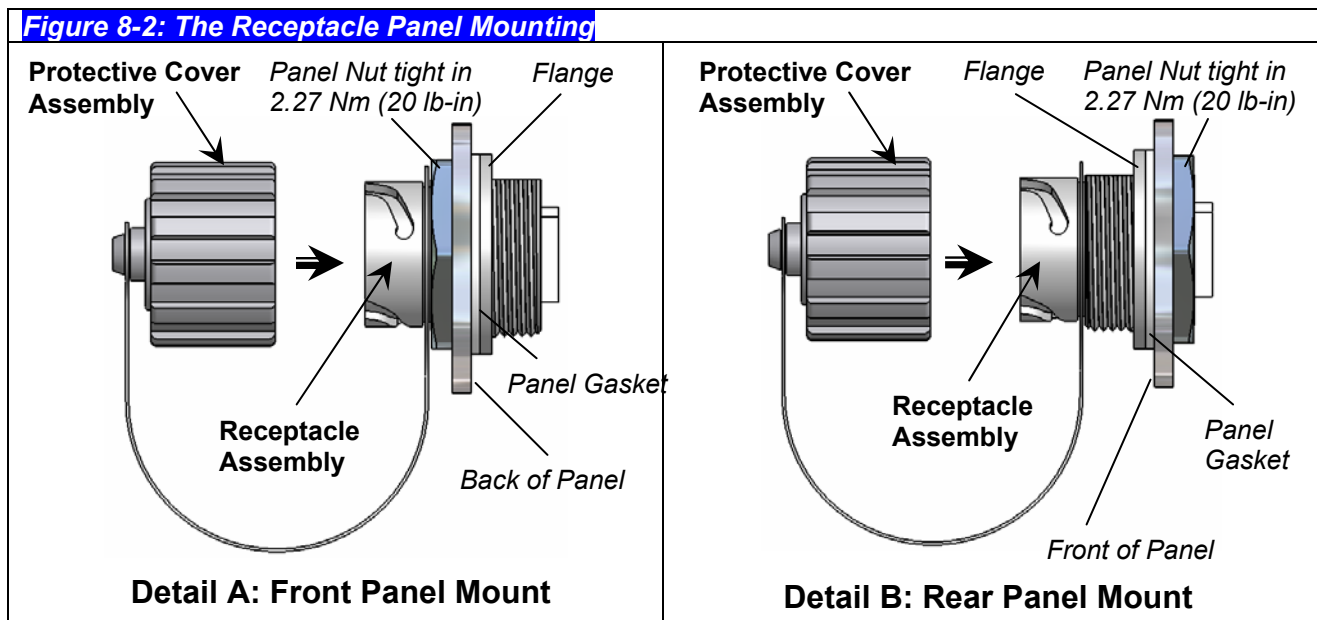

9 Connector Engagements

9.1 RJ45 Jack and Plug Engagement (Bayonet)

Gently insert the assembled plug (Bayonet) into the Jack adaptor of the RJ45 receptacle, align the 3 keys of the bayonet coupling ring with 3 bayonet channels of the receptacle and rotate the bayonet coupling ring until the 3 keys “click” into the bayonet channels. See **Detail A** of Figure 9-1.

9.2 RJ45 Jack and Plug Engagement (Cable Strain Relief)

Gently insert the assembled plug (Thread) into the Jack adaptor of the RJ45 receptacle then fully thread the M28 coupling ring. See **Detail B** of the Figure 9-1.

9.3 Protective Cover Engagement

The protective cover must be installed onto the **Receptacle Assembly** and engaged with the receptacle immediately for insuring IP67 sealing performance whenever the **Plug Assembly (Bayonet)** is removed from the **Receptacle Assembly**.

The tether of the protective cover should be attached to the **Receptacle Assembly** if it is to be used. Place the loop of the tether in the groove (located between the end of the bayonet channels and the hex nut) of the **Receptacle Assembly**. See **Detail C** of Figure 9-1.

Figure 9-1: Connector Engagement

