

TO-92 Encapsulate Adjustable Reference Source

CJ432 Adjustable Accurate Reference Source

DEVICE DESCRIPTION

The CJ432 is a three-terminal Shunt Voltage Reference providing a highly accuracy 1.24V. The CJ432 thermal stability and wide operating current, makes is sritable for all variety of applications that are looking for a low cost solution with high performance.

FEATURES

- Low dynamic output impedance
- The effective temperature compensation in the working range of full temperature
- Low output noise voltage
- Fast on -state response
- Sink current capability of 0.1mA to100mA

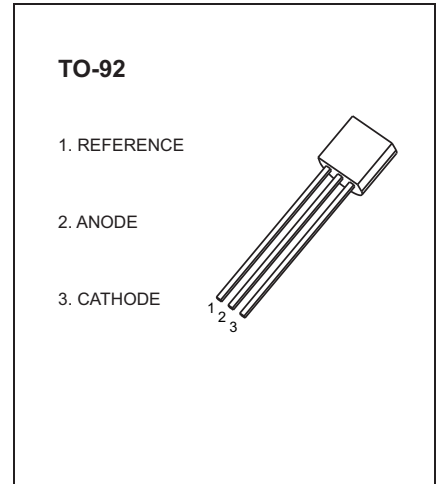

APPLICATION

- Shunt Regulator
- High-Current Shunt Regulator
- Precision Current Limiter

MARKING

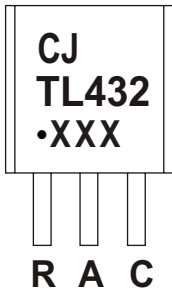

TL432=Device code
 Solid dot=Green molding compound device, if none,the normal device
 XXX=Code

Equivalent Circuit

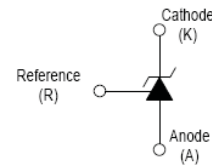

ORDERING INFORMATION

Part Number	Package	Packing Method	Pack Quantity
CJ432	TO-92	Bulk	1000pcs/Bag
CJ432-TA	TO-92	Tape	2000pcs/Box

ABSOLUTE MAXIMUM RATINGS (Operating temperature rangeapplies unless otherwise specified)

Parameter	Symbol	Value	Unit
Cathode Voltage	V_{KA}	18	V
Cathode Current Range (continuous)	I_{KA}	100	mA
Reference Input Current Range	I_{ref}	6	μA
Power Dissipation	P_D	500	mW
Thermal Resistance from Junction to Ambient	$R_{\theta JA}$	250	$^{\circ}C/W$
Operating Temperature	T_{opr}	0~+70	$^{\circ}C$
Junction Temperature	T_J	150	$^{\circ}C$
Storage Temperature	T_{stg}	-65~+150	$^{\circ}C$

ELECTRICAL CHARACTERISTICS

$T_a=25^\circ\text{C}$ unless otherwise specified

Parameter	Symbol	Test conditions	Min	Typ	Max	Unit
Reference input voltage (Fig 1)	V_{ref}	$V_{\text{KA}}=V_{\text{REF}}, I_{\text{KA}}=10\text{mA}$	1.2214		1.2586	V
Deviation of reference voltage over full temperature range (Fig 1)	$\Delta V_{\text{ref(DEV)}}$	$V_{\text{KA}}=V_{\text{REF}}, I_{\text{KA}}=10\text{mA}$ $0^\circ\text{C}\leq T_a\leq 70^\circ\text{C}$			16	mV
Ratio of change in reference input voltage to the change in cathode voltage (Fig 2)	$\Delta V_{\text{ref}}/\Delta V_{\text{KA}}$	$I_{\text{KA}}=10\text{mA}$, $\Delta V_{\text{KA}}=1.25\text{V}\sim 15\text{V}$			2.4	mV/V
Deviation of reference input current over full temperature range (Fig 2)	$\Delta I_{\text{ref}}/\Delta T$	$I_{\text{KA}}=10\text{mA}$, $R_1=10\text{K}\Omega$, $R_2=\infty$, $0^\circ\text{C}\leq T_a\leq 70^\circ\text{C}$			0.6	μA
Minimum cathode current for regulation (Fig 1)	$I_{\text{KA(min)}}$	$V_{\text{KA}}=V_{\text{REF}}$			0.1	mA
Off-state cathode current (Fig 3)	I_{off}	$V_{\text{KA}}=15\text{V}, V_{\text{REF}}=0$			0.5	μA
Dynamic impedance	Z_{KA}	$V_{\text{KA}}=V_{\text{REF}}, I_{\text{KA}}=0.1\sim 20\text{mA}$, $f\leq 1.0\text{kHz}$			0.5	Ω

CLASSIFICATION of V_{ref}

Rank	1%	1.5%
Range	1.2276~1.2524	1.2214~1.2586

Figure 1. Test Circuit for $V_{\text{KA}} = V_{\text{ref}}$

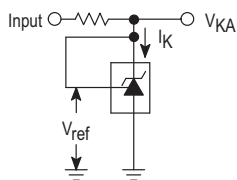

Figure 2. Test Circuit for $V_{\text{KA}} > V_{\text{ref}}$

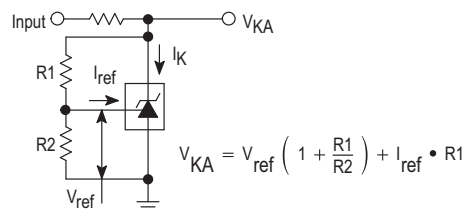
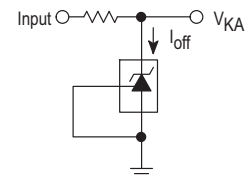
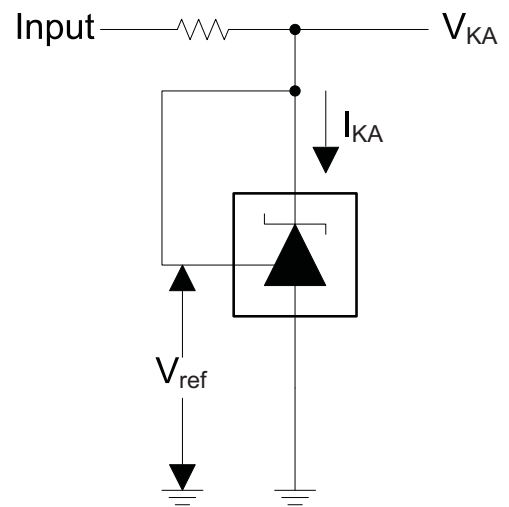
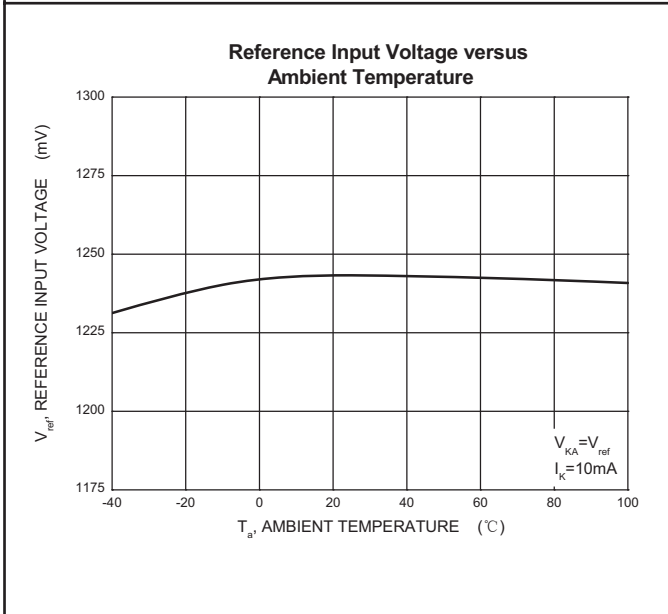
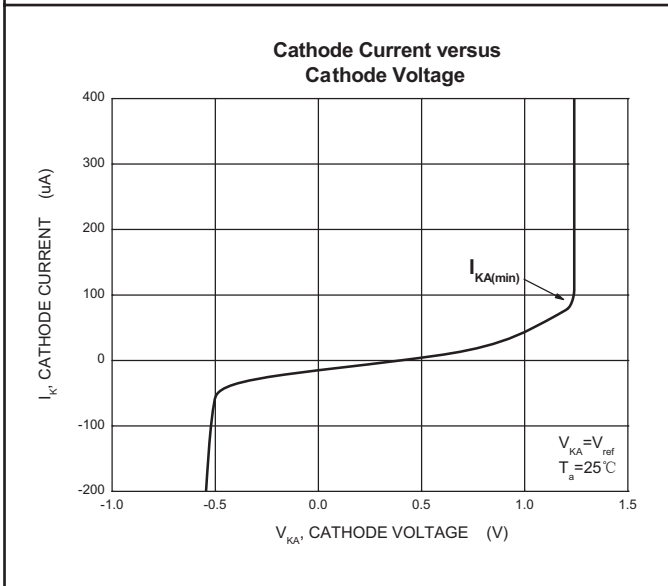
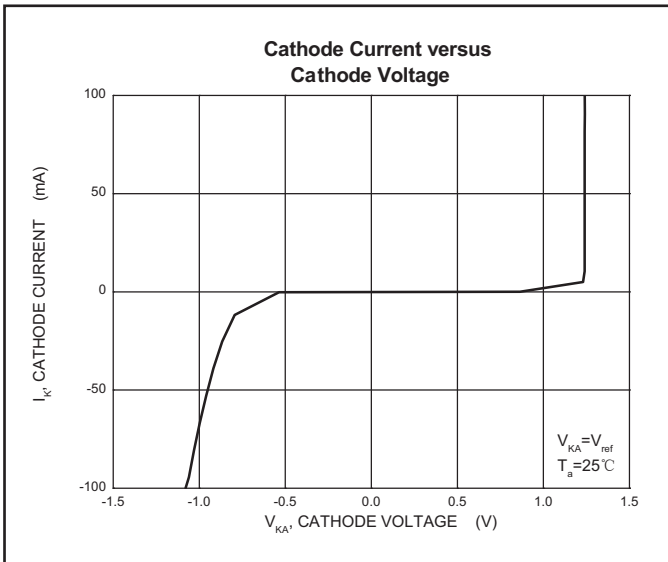

Figure 3. Test Circuit for I_{off}



Typical Characteristics



Test Circuit for $V_{KA} = V_{ref}$

Typical Characteristics

Change in Reference Input Voltage versus Cathode Voltage

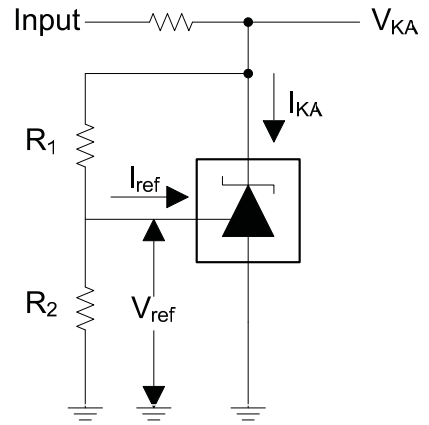
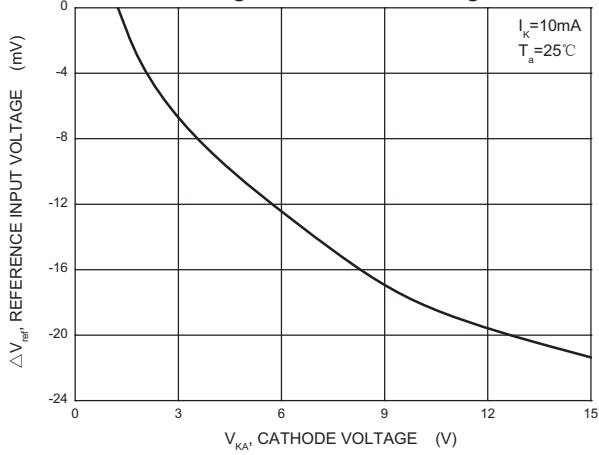

Test Circuit for $V_{KA} = V_{ref}(1 + R_1/R_2) + R_1 \cdot I_{ref}$

Reference Input Current versus Ambient Temperature

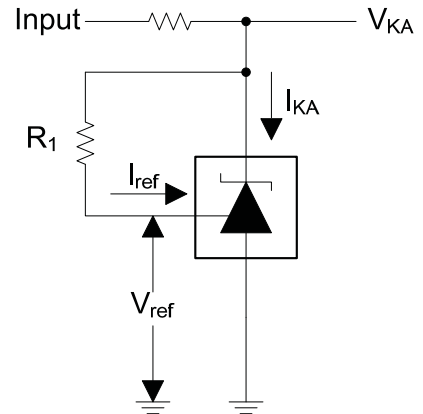
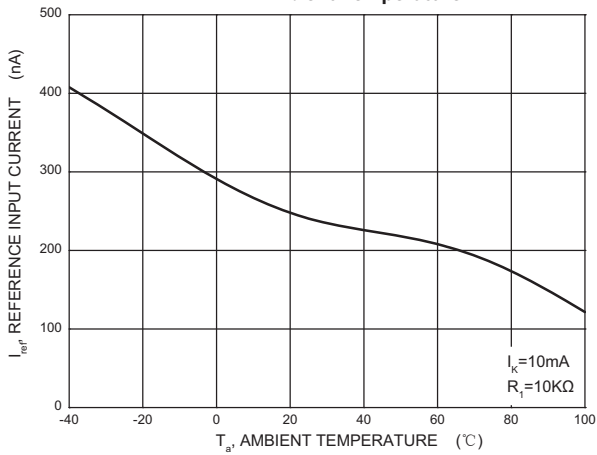

Test Circuit for I_{ref}

Off-State Cathode Current versus Ambient Temperature

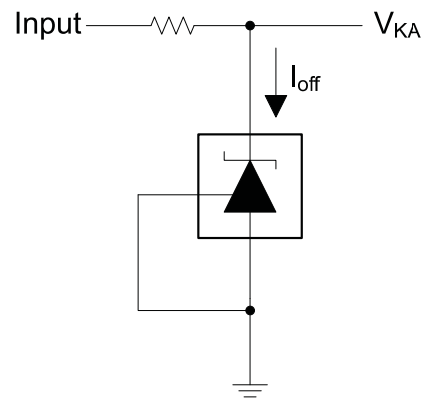
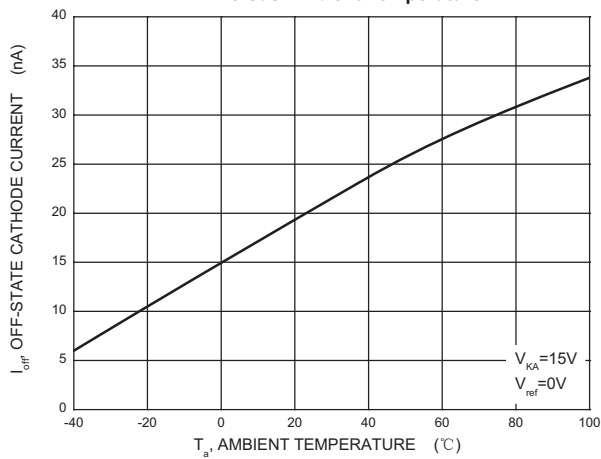

Test Circuit for I_{off}

TO-92 Package Outline Dimensions

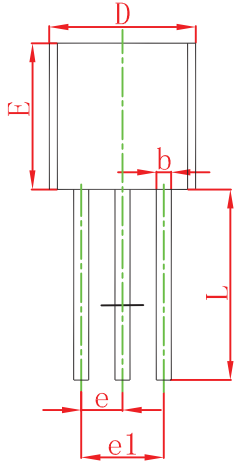
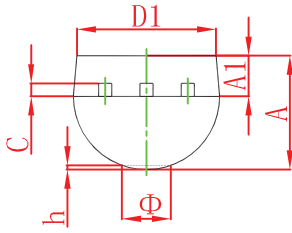

Symbol	Dimensions In Millimeters		Dimensions In Inches	
	Min	Max	Min	Max
A	3.300	3.700	0.130	0.146
A1	1.100	1.400	0.043	0.055
b	0.380	0.550	0.015	0.022
c	0.360	0.510	0.014	0.020
D	4.300	4.700	0.169	0.185
D1	3.430		0.135	
E	4.300	4.700	0.169	0.185
e	1.270 TYP		0.050 TYP	
e1	2.440	2.640	0.096	0.104
L	14.100	14.500	0.555	0.571
Φ		1.600		0.063
h	0.000	0.380	0.000	0.015

TO-92 Suggested Pad Layout

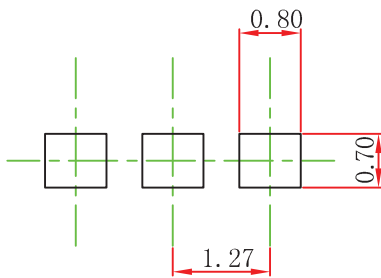

Note:

1. Controlling dimension: in millimeters.
2. General tolerance: $\pm 0.05\text{mm}$.
3. The pad layout is for reference purposes only.

NOTICE

JCET reserve the right to make modifications, enhancements, improvements, corrections or other changes without further notice to any product herein. JCET does not assume any liability arising out of the application or use of any product described herein.

TO-92 PACKAGE TAPEING DIMENSION

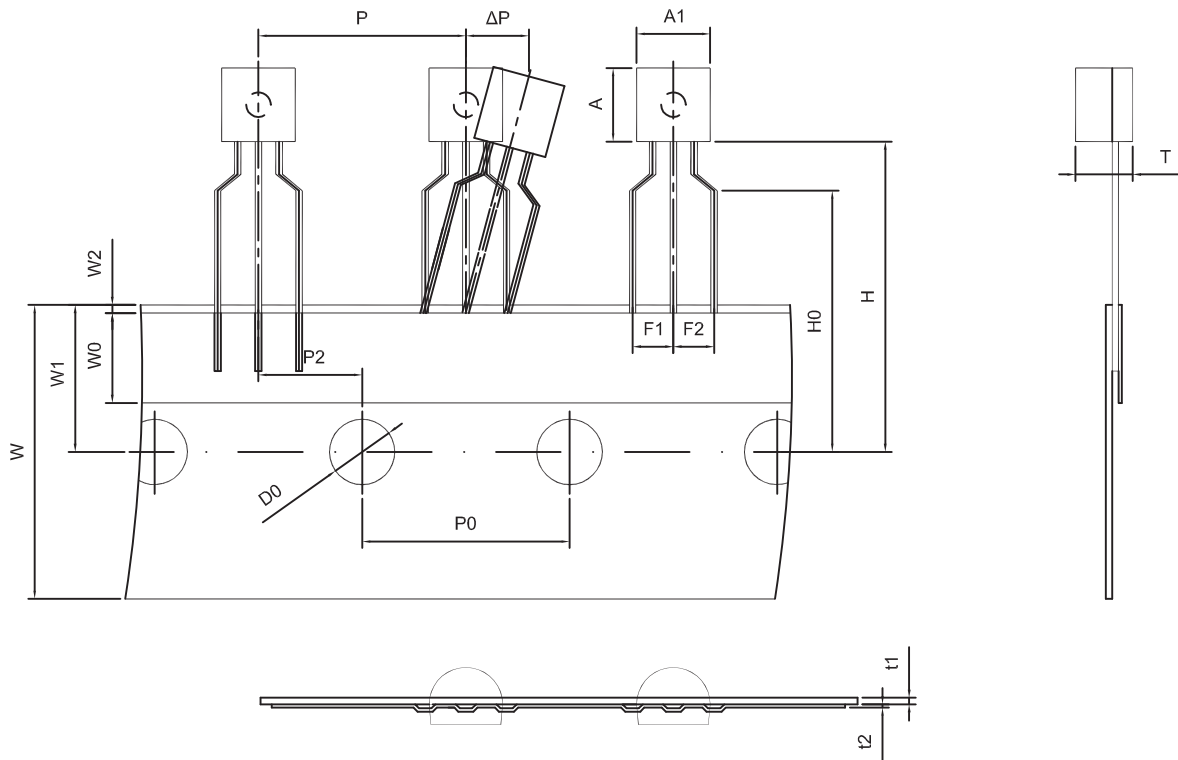

Dimiensions are in millimeter								
A1	A	T	P	P0	P2	F1	F2	W
4.5	4.5	3.5	12.7	12.7	6.35	2.5	2.5	18.0
W0	W1	W2	H	H0	D0	t1	t2	ΔP
6.0	9.0	1.0 MAX.	19.0	16.0	4.0	0.4	0.2	0

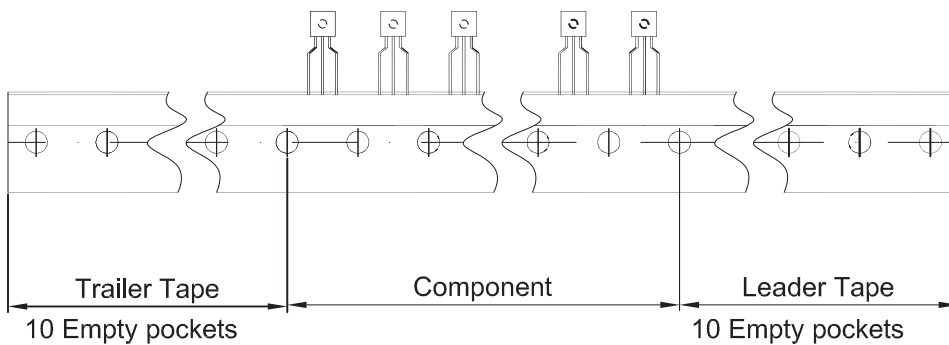

Package	Box	Box Size(mm)	Carton	Carton Size(mm)
TO-92	2000 pcs	333×162×43	20,000 pcs	350×340×250