

MAPX	MODIFICATION	DATE
------	--------------	------

NOTES:  
 1. MATERIAL:  
 1.1 HOUSING:PA6T+30% G/F, COLOR:BLACK, UL 94V-0;  
 1.2 CONTACTS: PHOSPHOR BRONZE  
 1.3 SHELL :PHOSPHOR BRONZE OR SK7  
 1.4 ISOLATED:PHOSPHOR BRONZE OR SK7  
 1.5 REAR SHELL :SPCC  
 2. FINISH:  
 2.1 CONTACT:  
 GOLD/SEE TABLE) PLATING ON CONTACT AREA.  
 100u" MIN. BRIGHT-TIN PLATING ON SOLDER TAIL  
 AREA.50u" MIN. NICKEL UNDERPLATING OVERALL,  
 2.2 SHELL:  
 100u" MIN. NICKEL UNDERPLATING.  
 2.3 ISOLATED:SHELL: 100u" MIN. NICKEL PLATED  
 2.4 REAR SHELL:100u" MIN. NICKEL PLATED.  
 3. ELECTRICAL CHARACTERISTICS:  
 CURRENT RATING: 0.5Ampere Maximum  
 VOLTAGE: 30V AC.  
 CONTACT RETENTION: FORCE:0.7KG/MINIMUM.  
 CONTACT RESISTANCE: 30 MILLIOHMS MAXIMUM.  
 INSULATION RESISTANCE: 1000MEGDHMS MINIMUM.  
 DIELECTRIC WITHSTANDING VOLTAGE: 750V AC AT SEE LEVEL.  
 TEMPERATURE: -55°C~85°C .

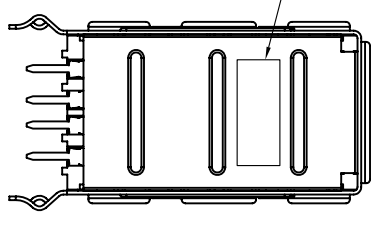
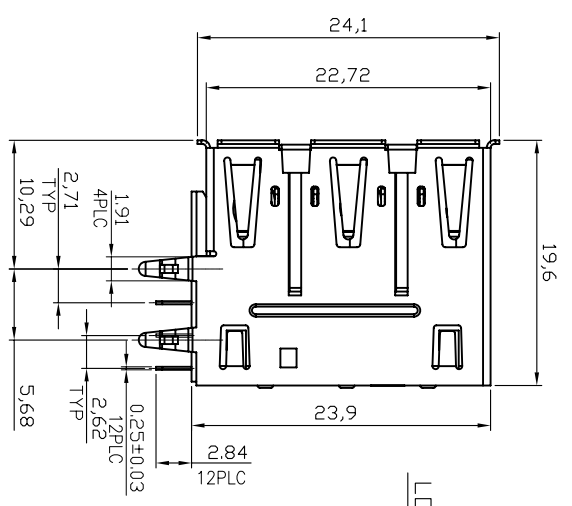
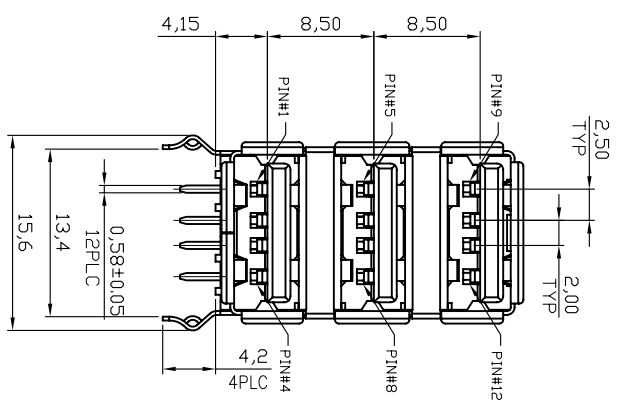
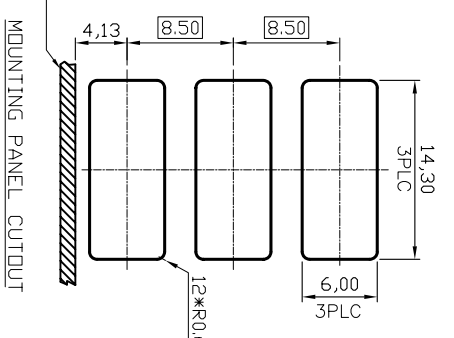
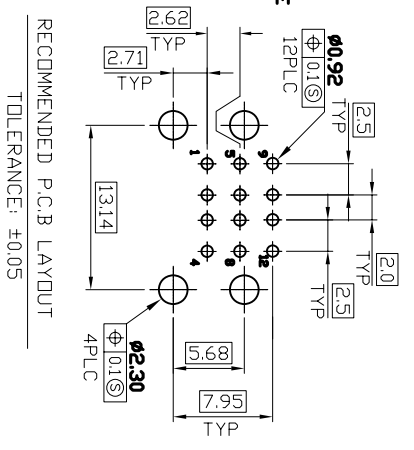
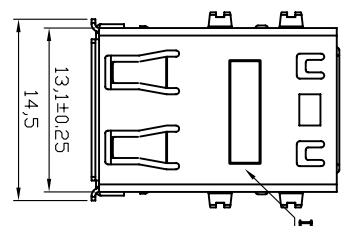

产品图  
公差一览表  
PRODUCT CHART DWG

TOLERANCE UNLESS OTHERWISE SPECIFIED	公差一览表
X ±0.35	X ±5°
X ±0.30	X ±2°
XX ±0.20	XX ±1°
XXX ±0.10	XXX ±0.5°

单位: MM  
比例: 1:1  
日期: 2013-06-15

制图: Gavin  
审核: 郭治富  
核准: 黄国荣

制图料号: PRODUCT PART NO.  
产品名称: TRIPLE STACKED USB, A TYPE R/A,  
PRODUCT NO: RECEPTACLE/DIP CONNECTOR  
角法: 版本: AD

1 2 3 4 5 6 7 8 9 10  
G F E D C B A  
G F E D C B A

深圳市精拓金电子有限公司