

ROHS

MAPX

MODIFICATION

DATE

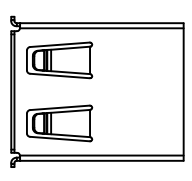

12.42±0.15

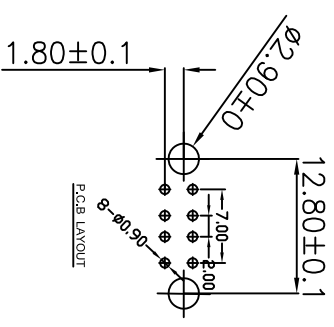
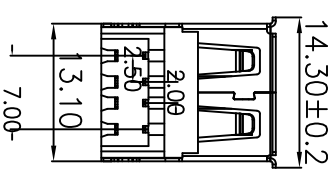
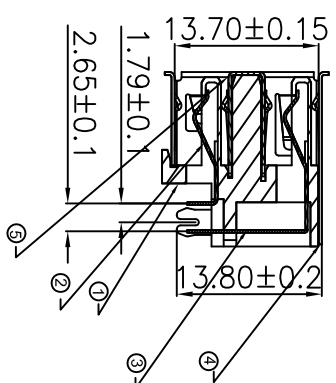
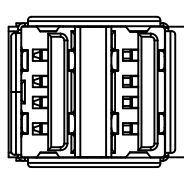
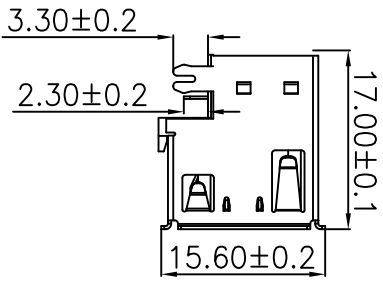

- 电气特性:Electrical:
1. 额定电流: Current Rating  
1.5A/contact terminal
  2. 额定电压: Voltage Rating  
30V DC
  3. 接触阻抗: Contact Resistance  
30 milliohms MAX
  4. 耐电压: Dielectric Withstanding Voltage:  
500 V AC AT Sea Level
  5. 绝缘阻抗: Insulation Resistance:  
1000MEGA ohms MIN
- 物理性能:Mechanical:
1. 插拔力: Connector Mate and Unmate Force  
Mate force:3.57kgf (MAX)  
Unmate force:1.02kgf (MIN)
  2. 端子保持力: Terminal Retention  
1.0kgf (MIN)

- 原材料:Material:
- Hing Temperature Thermoplastics,  
1. 塑胶:Housing:  
PBI White/Black
2. 端子:Contact:Copper Alloy C26880  
Plated Gold in Mating Area;  
Tin On Solder Tails
  3. 外壳:Shell: Copper Alloy SPCC  
Nickel Plating

# 深圳市精拓金电子有限公司

## 产品图

PRODUCT CHART DWG

公差一览表

TOLERANCE UNLESS OTHERWISE SPECIFIED	公差
X	±0.35
X	±0.20
.XX	±0.10
.XXX	±0.05

单位	MM	制图	许增强	制料号
UNITS	MM	DRAWING	许增强	PRODUCT DRAWING NO.
比例	1:1	审核	郭治富	产品名称
SCALE	1:1	GDW	郭治富	USB A母双层沉板无后盖无边
日期	2016-09-09	核准	黄国荣	角法
DATE	2016-09-09	APPD	黄国荣	版本
				A0

NL	Part Name	MATERIAL	THICK	FINISH	Q'TY
5	SHELL-B	Fe	T=0.30	N 180-100U <sup>+</sup>	1
4	SHELL-A	Fe	T=0.30	N 180-100U <sup>+</sup>	1
3	TERMINAL-B	BRASS	T=0.25	Sn 100U <sup>+</sup> + Au 1.30U <sup>+</sup>	4
2	TERMINAL-A	BRASS	T=0.2	Sn 100U <sup>+</sup> + Au 1.30U <sup>+</sup>	4
1	HOUSING	PBT		WHITE/BLACK	1