

MAPX	MODIFICATION	DATE
------	--------------	------

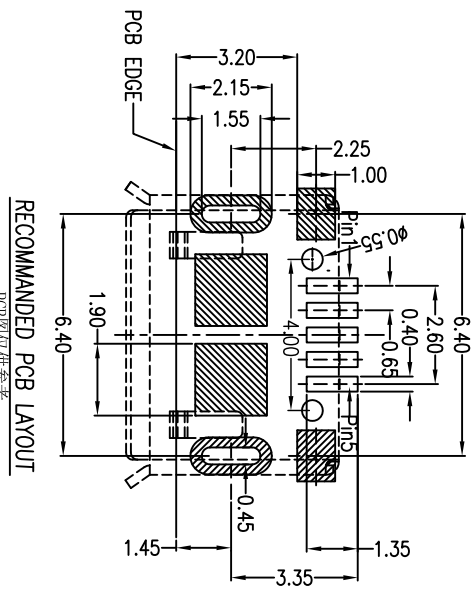
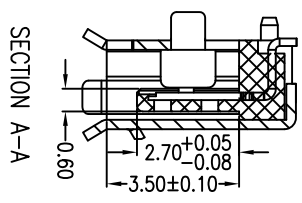
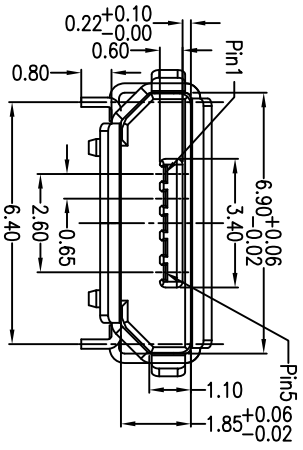
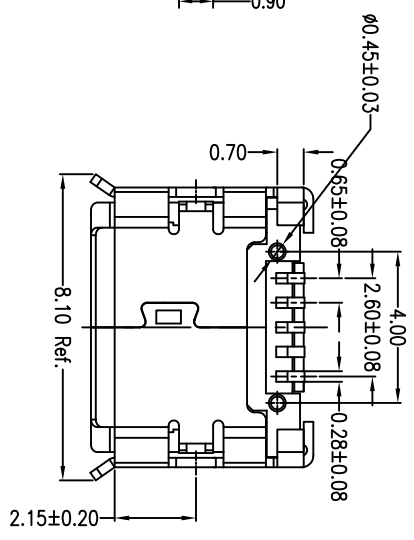
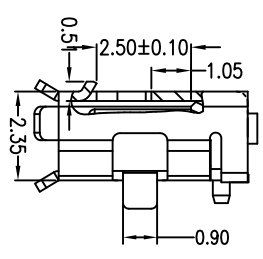
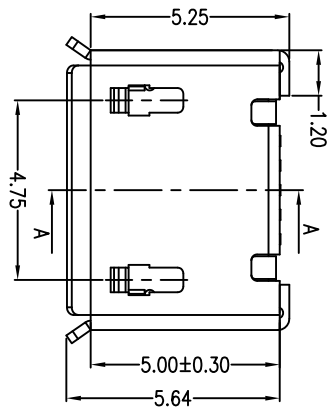
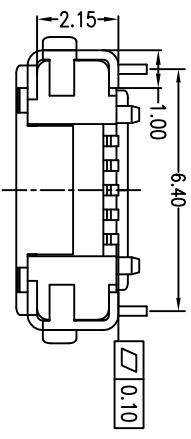

- Note:
1. Material:
- 1.1 Housing: High temperature thermoplastic with g.f. UL94v-0
 - 1.2 Contact: copper alloy, t=0.20mm
 - 1.3 Shell: copper alloy or sus, t=0.25mm
2. Specification:
- 2.1 Current rating: 1.5PIN 1.8A Max/2.3,4PIN 1A Max.
 - 2.2 Dielectric withstanding voltage: 100 V(ac) for 1 min.
 - 2.3 Contact resistance: 30 mΩ Max.
 - 2.4 Insulation resistance: 100 MΩ Min.
 - 2.5 Total mating force: 3.57 Kgf Max.
 - 2.6 Total unmating force: 1.0 Kgf Min.
 - 2.7 Temperature range: -30°C~80°C

产品图
公差一览表
PRODUCT CHART DWG
深圳市精拓金电子有限公司

TOLERANCE UNLESS OTHERWISE		单位	制图	制料号
X	±0.35	MM	Gavin	PRODUCT PART NO
X	±0.30	比例	审核	产品名称
XX	±0.20	SCALE	郭治富	Micro usb 5s B Type有脚脚有注
XXX	±0.10	DATE	核准	角法
		2016-06-05	黄国荣	版本
			APPD	VER
				AD

1 2 3 4 5 6 7 8 9 10