

MAPX	MODIFICATION	DATE
------	--------------	------

NOTES:

1. HOUSING: SEE NOTES, UL94V-0 .
TERMINAL: SEE NOTES.
SHELL: SEE NOTES.

SPECIFICATION:

1. ELECTRICAL CHARACTERISTIC:
CONTACT RESISTANCE: 30MΩ MAX
DIELECTRIC WITHSTANDING VOLTAGE: 500V AC FOR 1MIN
INSULATION RESISTANCE: 1000MΩ MIN
2. MECHANICAL CHARACTERISTIC:
INSERTION FORCE: 35N(3.57KGF) MAX
EXTRACTION FORCE: 10~35N(1.02~3.57KGF) MIN
DURABILITY: 1500 CYCLES EXTRACTION FORCE:10~35N
5000 CYCLES MIN
3. ENVIRONMENTAL:
OPERATING TEMPERATURE: -55°C+85°C
4. Contact finish:
01:Selective Gold Flash
02:Selective Gold 3U"
03:Selective Gold 5U"
04:Selective Gold 15U"
05:Selective Gold 30U"

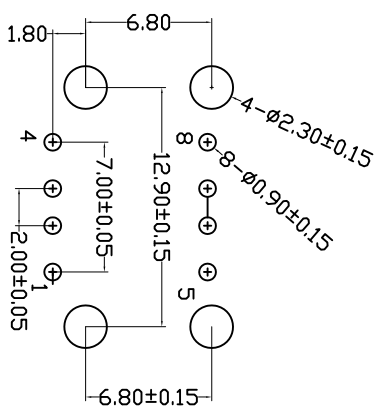
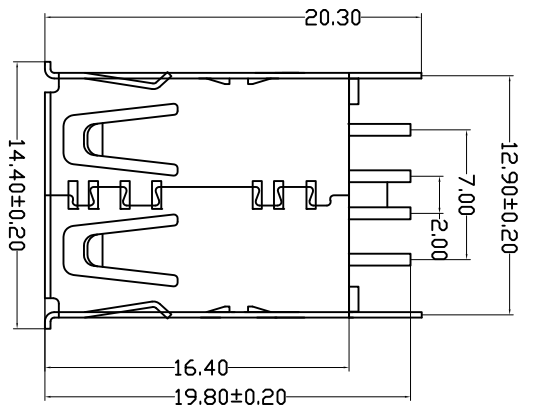

RECOMMENDBD P.C.B PATTRBN LAY OUT

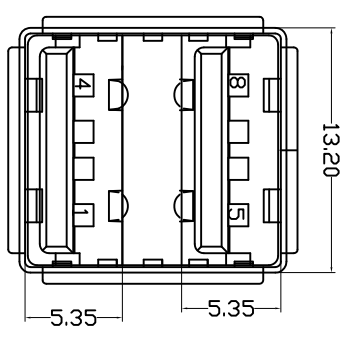
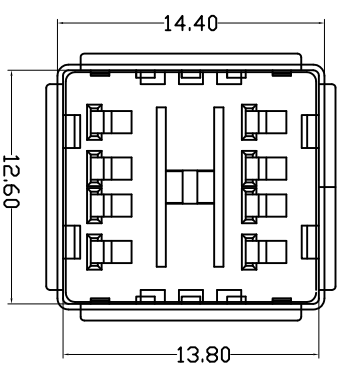
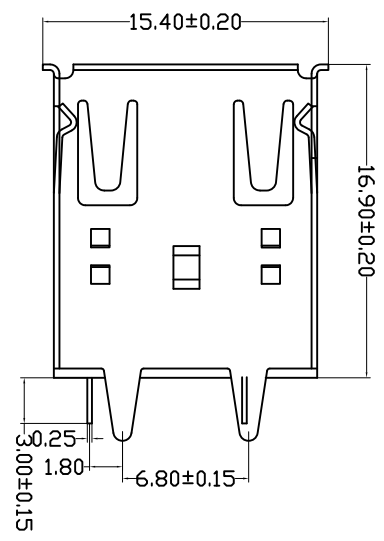

产品图
PRODUCT CHART DWG

深圳市精拓金电子有限公司

公差一览表 TOLERANCE UNLESS OTHERWISE		单位 UNITS	MM	制图 DRAWING	Z-Y-B	制图料号 PRODUCT PART NO.	
X	±0.15	X	±5°	审核 CHKD		产品名称 PRODUCT NO.	USB AP 双层直插7.0MM弯
X	±0.10	X	±2°	日期 DATE	2012.06.10	角法 VIEW	
XX	±0.05	XX	±1°	批准 APPD		版本 VER	AD
XXX	±0.03	XXX	±0.5°				

1 2 3 4 5 6 7 8 9 10