

MAPX	MODIFICATION	DATE
------	--------------	------

NOTES:

- HOUSING: SEE NOTES, TERMINAL: SEE NOTES, SHELL: SEE NOTES.

SPECIFICATION:

- ELECTRICAL CHARACTERISTIC:
CONTACT RESISTANCE: 30MΩ MAX
DIELECTRIC WITHSTANDING VOLTAGE: 500V AC FOR 1MIN
INSULATION RESISTANCE: 1000MΩ MIN
- MECHANICAL CHARACTERISTIC:
INSERTION FORCE: 35N(3.57KGF) MAX
EXTRACTION FORCE: 10~35N(1.02~3.57KGF) MIN
DURABILITY: 1500 CYCLES EXTRACTION FORCE: 10~35N
5000 CYCLES MIN
5000 CYCLES EXTRACTION FORCE: 3~35N

3. ENVIRONMENTAL:

OPERATING TEMPERATURE: -55°C+85°C

4. Contact finish:

- Selective Gold Flash
- Selective Gold 3U"
- Selective Gold 5U"
- Selective Gold 15U"
- Selective Gold 30U"

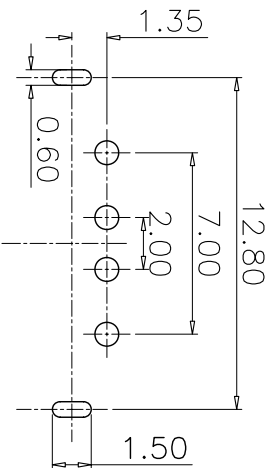
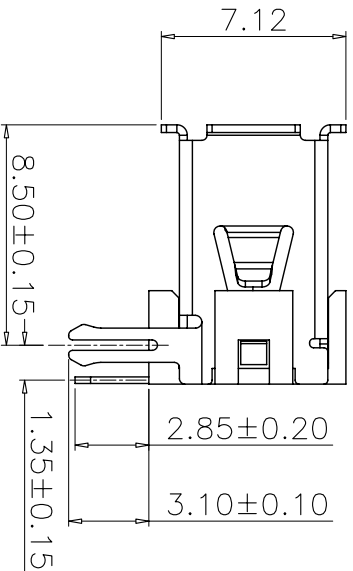
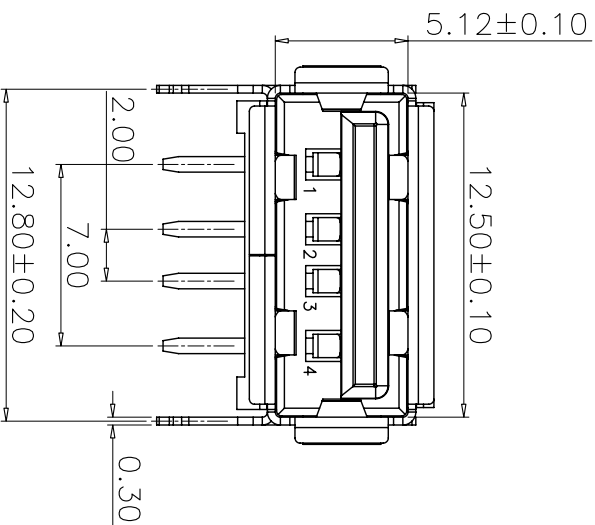
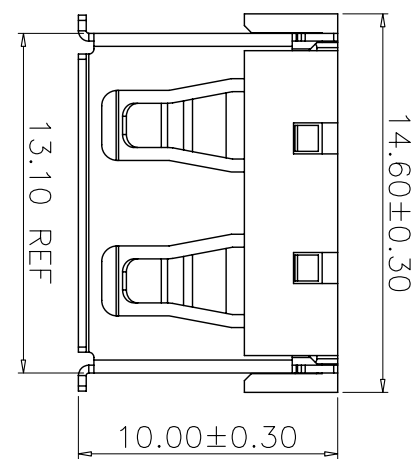

PCB HOLES(THE PATTERN SIDE)
NOTE:GENERAL TOLERANCE:±0.1mm

产品图
公差一览表

TOLERANCE UNLESS OTHERWISE	公差
X	±0.15
.X	±0.10
.XX	±0.05
.XXX	±0.03

深圳市精拓金电子有限公司

UNIT	UNIT	SCALE	DATE	DATE	APPD	DATE	DATE	DATE
MM	MM	1:1	2010.05.06					

制图料号: USB A/F 10.0-B-004

产品名称: USB A/F 10.0 (后两脚有边)

版本: A0